

E9016
7/25/95

NASA Technical Memorandum 4635

NASA Low-Speed Axial Compressor for Fundamental Research

Charles A. Wasserbauer, Harold F. Weaver, and Richard G. Senyitko

JULY 1995

Corrected Copy



National Aeronautics and
Space Administration

NASA Low-Speed Axial Compressor for Fundamental Research

Charles A. Wasserbauer
Sverdrup Technology, Inc.
Lewis Research Center Group
Brookpark, Ohio

Harold F. Weaver
National Aeronautics and Space Administration
Lewis Research Center
Cleveland, Ohio

Richard G. Senyitko
Sverdrup Technnology, Inc.
Lewis Research Center Group
Brookpark, Ohio



National Aeronautics and
Space Administration

Office of Management

Scientific and Technical
Information Program

1995

NASA Low-Speed Axial Compressor for Fundamental Research

Charles A. Wasserbauer
Sverdrup Technology, Inc.
Lewis Research Center Group
Brook Park, Ohio 44142

Harold F. Weaver
National Aeronautics and Space Administration
Lewis Research Center
Cleveland, Ohio 44135

and

Richard G. Senyitko
Sverdrup Technology, Inc.
Lewis Research Center Group
Brook Park, Ohio 44142

Summary

A low-speed, multistage axial compressor, constructed at the NASA Lewis Research Center, is described. The purpose of this compressor is twofold: to increase the understanding of the complex flow phenomena occurring in multistage axial compressors, and to obtain detailed data from a multistage compressor environment for use in developing and verifying models for computational fluid dynamic code assessment. The compressor has extensive pressure instrumentation in both stationary and rotating frames of reference, and has provisions for flow visualization and laser velocimetry. The compressor will accommodate rotational speeds to 1050 rpm and is rated at a pressure ratio of 1.042.

Introduction

Both industry and government have placed increased emphasis on improving the performance of high-speed, multistage axial compressors. Much effort has been expended to obtain quite detailed measurements of the flows in large axial compressors. These measurements are used to develop empirical models that reflect the flow processes in actual blade rows (refs. 1 to 5). Such information has provided a better insight into the physical processes occurring in a rotating channel. Although compressor performance has been improved by using these empirical design procedures, they require an extensive data base, which is usually proprietary to individual companies. Further gains in performance for axial compressors are expected to be obtained by using improved computational codes for design and analysis. In the past decade, NASA Lewis

has embarked on a major research program to provide the information and tools necessary to advance both component and system technologies. Ultimately, experiments and analyses must be applied to realistic, high-speed, axial-flow compressors; however, many of the key flow phenomena that control the performance of multistage compressors can be effectively studied by using large-size, low-speed research hardware as shown by Day et al. (ref. 6). Using large-size hardware increases the size of endwall flow regions relative to the size of instrumentation; this allows more detailed study of the endwall regions.

A low-speed, multistage axial compressor has been designed and built at NASA Lewis (1) to execute detailed experiments that will identify relevant flow physics, (2) to provide interaction between detailed experiments and emerging average-passage and Navier-Stokes computational fluid dynamic (CFD) methods, and (3) to provide data needed for developing flow models used by the CFD codes. The goal of this research program is to develop efficient performance prediction capabilities for both design and off-design operating conditions. This report describes the major components and instrumentation of the low-speed, multistage axial compressor.

Facility

General Features

The NASA Low-Speed Compressor Facility was designed to accommodate large compressors, both centrifugal and axial. The major elements of the facility are shown in figure 1. Air is drawn from a filtered vent in the roof through a bank of steam

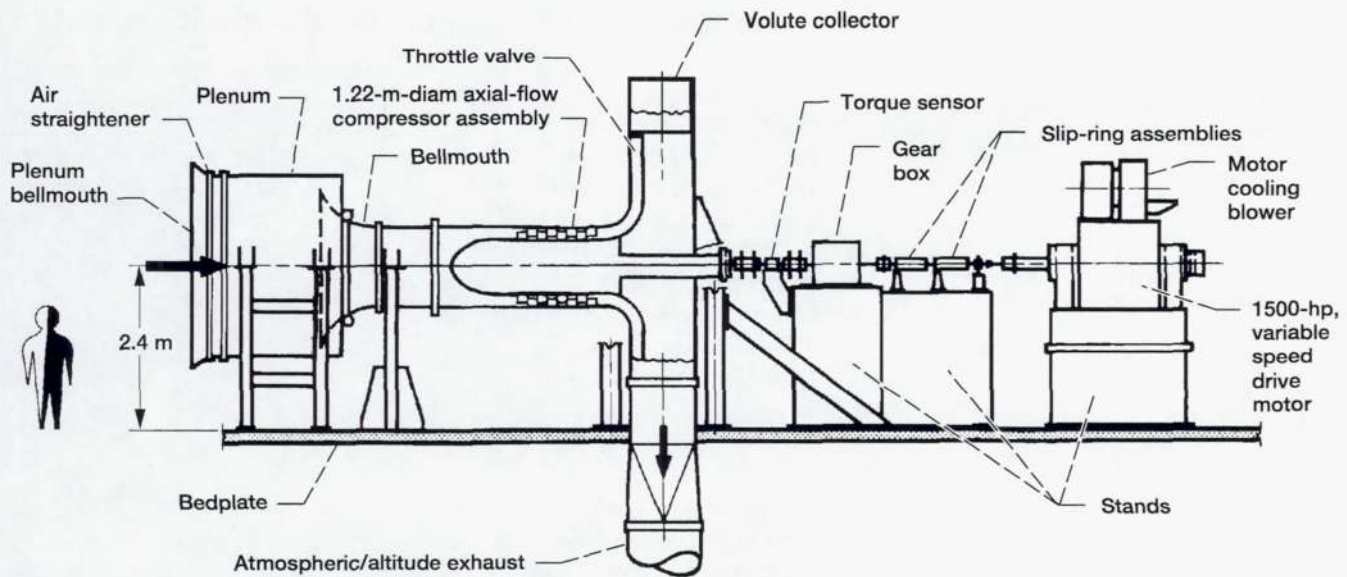

Figure 1.—NASA Low-Speed Compressor Facility.

pipes and louvers, which are designed to control the air temperature to within ± 0.5 K for mass flows up to 45 kg/sec. The flow enters the test cell and is drawn into the plenum through a bank of flow straighteners contained between two mesh screens. The air passes through a bellmouth specially designed with a 12.7:1 area contraction. The flow then enters the compressor and exits through a specially designed throttle valve at the entrance to the collector. The valve consists of two concentric rings with 10.2-cm-diam overlapping holes drilled in each so that the circumferential translation of one ring reduces the available flow area. This throttle valve design was chosen to minimize the circumferential asymmetry in the exit static pressure distribution that is typically found in scroll-type collectors. A complete description of the facility is provided by Wood et al. in reference 7.

Research in this facility was first done with a centrifugal compressor (refs. 8 to 10). The common elements for both the axial and centrifugal configuration, as shown in figure 1, are the plenum bellmouth inlet, the air straightener, the throttle valve, the volute collector/exhaust system, the gear box, both electronic and pneumatic slip-ring assemblies, and the variable-speed drive motor. The following facility elements were designed and fabricated for the axial configuration: the bellmouth, the 1.22-m-diam axial-flow compressor assembly, and a new diffusing bend, which is shown in figure 2.

Test Compressor

The low-speed axial compressor consists of four repeating stages (i.e., rotor and stator blade rows) plus an inlet guide vane (IGV) row, as shown in figure 3. The overall design requirements for the axial compressor are given in table I. The NASA compressor was modeled after a low-speed research

TABLE I.—DESIGN PARAMETERS FOR LOW-SPEED AXIAL COMPRESSOR

Tip speed	61.0 m/sec
Rotative speed	980 rpm
Axial velocity	24.4 m/sec
Mass flow	12.3 kg/sec
Pressure ratio	1.042
Temperature ratio	1.013
Tip radius	61.0 cm
Hub radius	48.8 cm
Blade span	12.2 cm
Aspect ratio (span/chord)	
Rotor	1.20
Stator	1.31
Aerodynamic chord midspan	
Rotor	10.2 cm
Stator	9.4 cm
Blade setting angle midspan	
Rotor	43°
Stator	42°
Axially projected chord midspan	
Rotor	7.6 cm
Stator	6.6 cm
Number of blades	
Rotor	39
Stator and IGV	52
Axial gap between blade rows	
	2.54 cm
Clearances	
Rotor tip	1.40-percent span; 0.17 cm
Stator seal	0.78-percent span; 0.09 cm

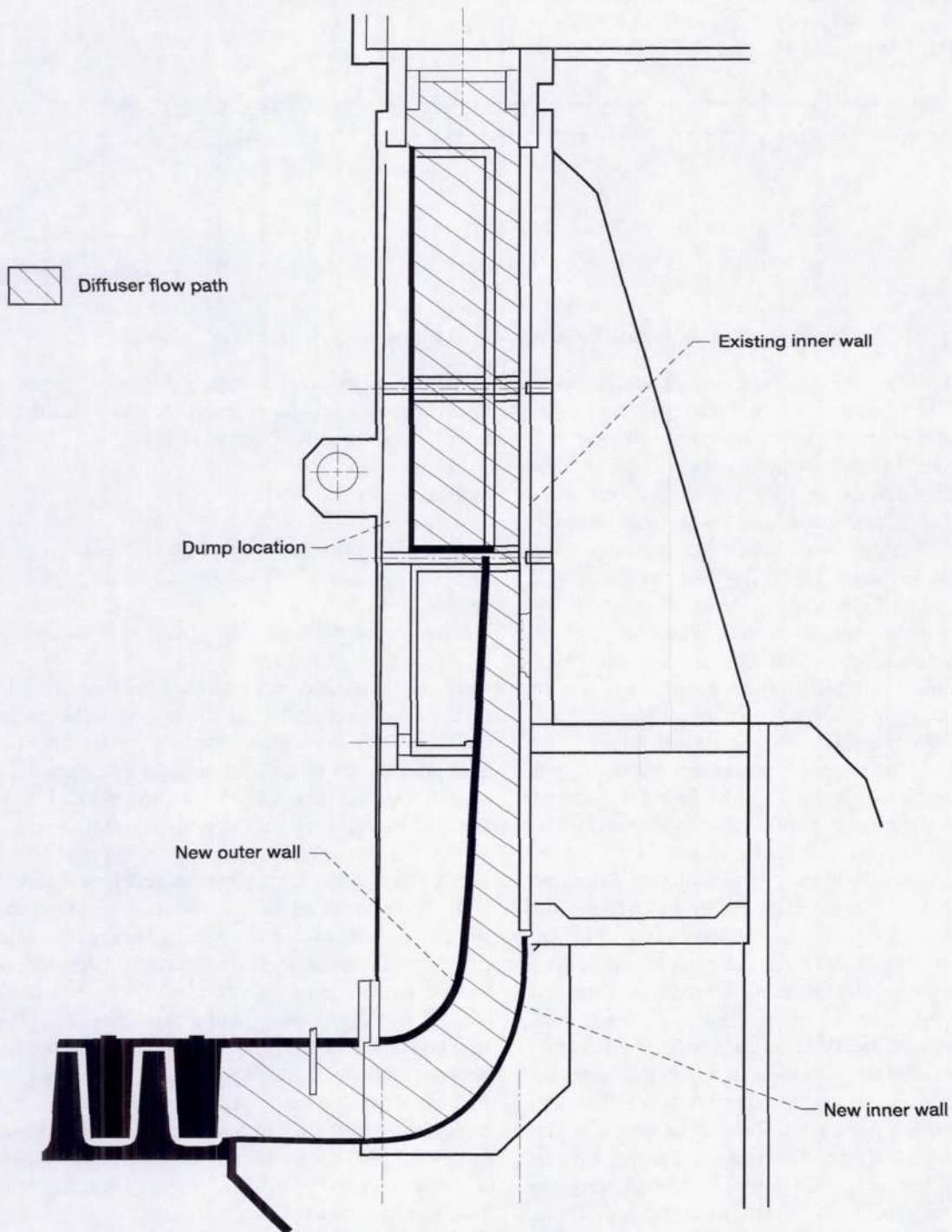

Figure 2.—Diffuser geometry for the multistage axial compressor.

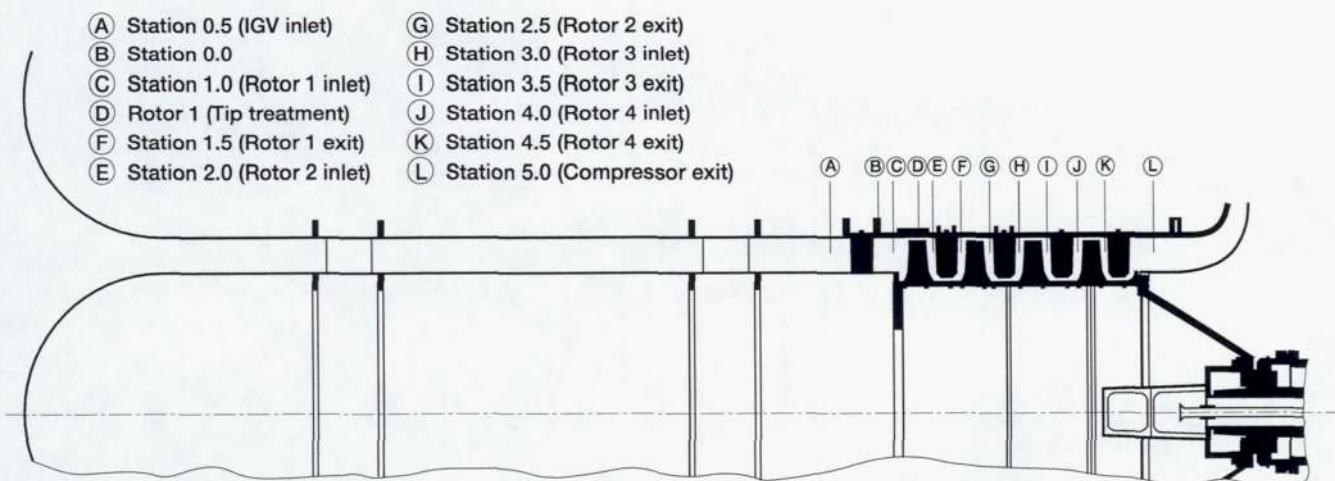

Figure 3.—Low-speed axial compressor aerodynamic survey locations.

compressor developed by the General Electric Co. during the 1950's. The blading, however, was designed after the model used in support of a program to develop energy efficient engines in the early 1980's. The NASA compressor incorporates many design features aimed at achieving an accurate, low-speed simulation of a high-speed, state-of-the-art multistage core compressor. The design philosophy was to consider the third stage to be the test stage. Thus, (1) a long entrance length develops thick endwall boundary layers typical of an embedded-stage environment, (2) the inlet guide vane and the first two compressor stages serve to present a true multistage flow field to the third stage, and (3) the fourth stage acts to buffer the third stage from the compressor exit conditions. Therefore, the third stage of this compressor will be the focus of future research efforts. Since the compressor was developed to enable investigation of the multistage flow field and to provide input for compressor performance prediction codes, all stages of the compressor were instrumented.

The compressor was designed to accommodate extensive instrumentation. A torquemeter (rated at 1130 N-m) for measuring overall work input has a nonlinearity of ± 0.34 N-m. Other instrumentation includes static pressures on the casing, hub, and blade surfaces, and in the stator footings. Standard aerodynamic survey probes can be used to measure total pressure, flow angle, and speed behind each blade row, including the inlet guide vanes. All stationary pressure measurements are recorded by an electronically scanned pressure (ESP) system that utilizes transducers rated to 6.9 kN/m^2 . The system has an accuracy of about $\pm 0.02 \text{ kN/m}^2$. The flow angle probes have an accuracy of $\pm 0.5^\circ$. Provisions for flow visualization, trace gas injection, and laser velocimetry are also included. In addition, the ability to survey in the rotating frame of reference is provided behind rotor 3. A block diagram of the research instrumentation is shown in figure 4. A host computer controls the ESP system and updates the calibration of each transducer periodically throughout the test. A second computer is dedicated to controlling the position of all aerodynamic survey probes,

so that surveys can be done automatically during testing (ref. 11). Both computers transmit the appropriate data to NASA Lewis' data acquisition system (ref. 12).

Special Features

To provide maximum versatility, a number of special features were incorporated in the compressor blading, casing, and hub section.

Blade.—The following are the special features of all the blade rows.

(1) There are two instrumented blades on one side and two counter-balanced blades on the opposite side of each rotor blade row, each made of aluminum. There are two instrumented aluminum blades for each stator blade row, except for the third stage which has four. All the other stator and rotor blades are made of fiberglass and are shown in figure 5.

(2) The compressor features stator blade row indexing, which is the ability to vary the circumferential location of one blade row relative to the other blade rows in the compressor. All stator blade rows have indexing capability except the inlet guide vane and the fourth stage stator. Each indexing blade row is free to move across almost two full blade pitches (i.e., about 12°) in the circumferential direction. Stator blade row indexing is used to accomplish probe area traverses between stages 1 and 3 by traversing the stator rows past fixed probes. Circumferential actuator pads are used ahead of stage 1 and downstream of stage 4 to accommodate area traverses.

(3) All blade rows in the compressor have the option of variable stagger (i.e., blade setting angle) adjustment, and can be adjusted prior to a research run.

(4) The number of rotor blades in each of the four stages can be changed as required. Each rotor blade is mounted on a separate rotor blade platform. Thus, the number of rotor blades in a blade row can be changed by changing the number of blade platforms. The IGV and stator blade rows were designed to hold 52 vanes or stator blades.

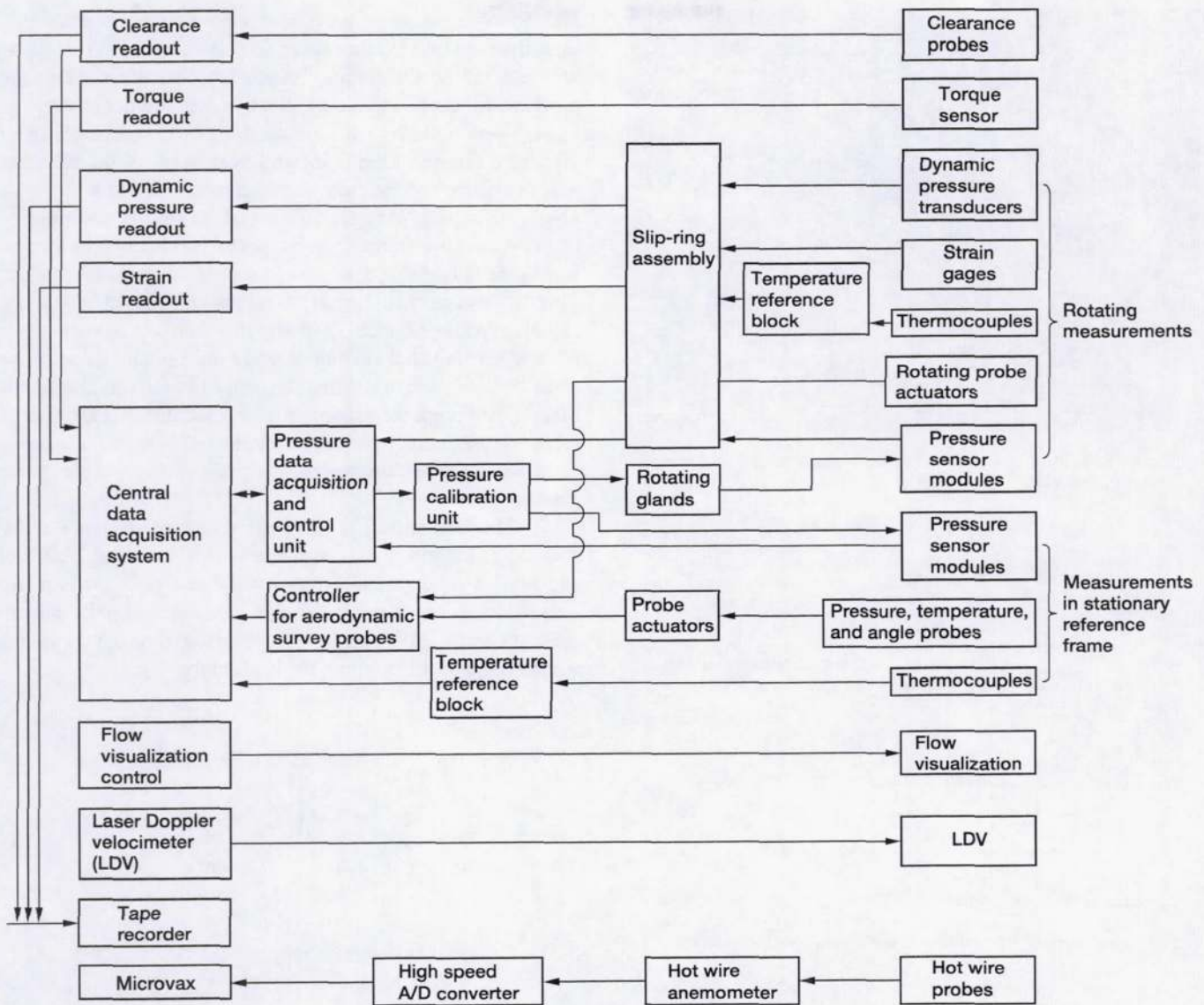

Figure 4.—Block diagram of compressor instrumentation system.

(5) All four stator rows are shrouded on the hub end by insertion into a stator footing. Figure 6 shows the details of the stator footings with a single labyrinth seal.

Casing.—The following are the special features of the casing.

(1) Circumferential grooves were provided in the casing wall over the tip of the first stage rotor (fig. 3). General Electric found this treatment necessary for their low-speed compressor to ensure that the first rotor did not set the stall point for the compressor. Since the NASA compressor was designed as a direct scale of the General Electric machine, tip treatment over the first rotor was also incorporated in the NASA design.

(2) Three windows, shown in figure 7, are provided in the casing for use in flow visualization, trace gas research, and in acquiring laser anemometer measurements. The first two

windows are located over the first and second stage rotor, respectively. The third window runs from the leading edge of the third stage rotor to the trailing edge of the fourth stage rotor. The third window also allows complete optical access to the third stage stator. The stator blades located under this window were mounted on the hub, and then rubber gaskets were mounted on the blade tips to prevent leakage across the stator tips at the casing. Solid metal covers are used for each window when optical access is not needed.

(3) Mounting pads were machined into the casing for aerodynamic survey probes and tip clearance probes at all axial survey stations. All actuators carry either cobra, wedge, Kiel, or hot wire probes. These probes are shown in figures 8, 9, 10, and 11, respectively. Probe locations are specified in table II.

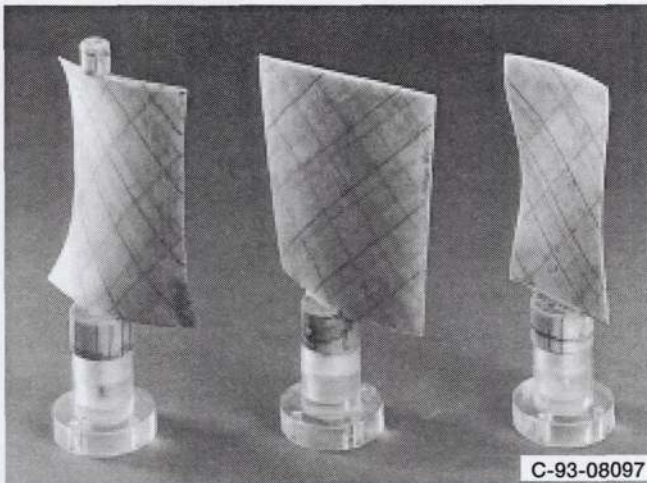

Figure 5.—Fiberglass airfoils (left to right): stator blade, rotor blade, and IGV.

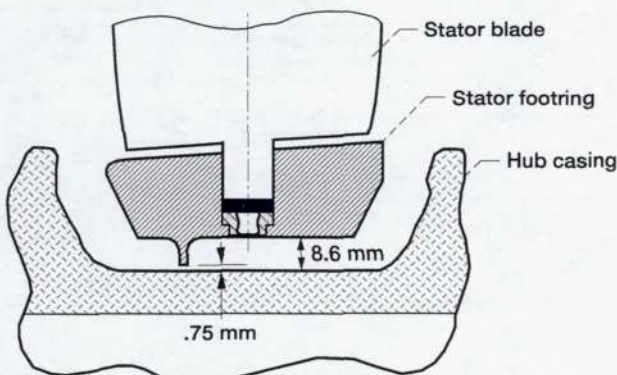

Figure 6.—Low-speed axial compressor stator footing.

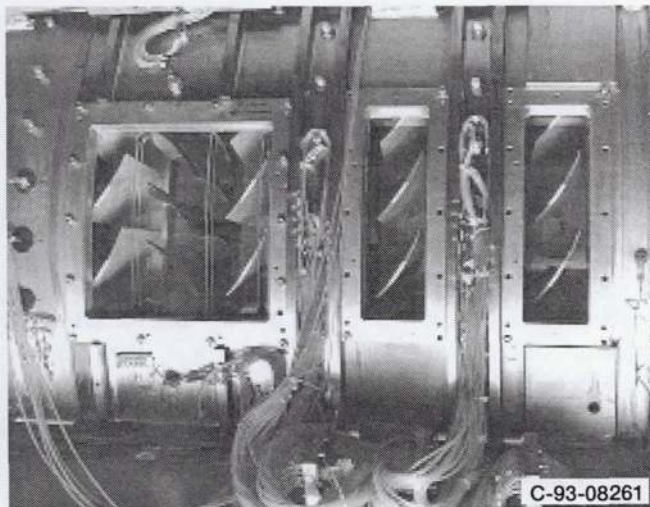

Figure 7.—Low-speed axial compressor windows.

The mounting pads for the probes are placed circumferentially, a multiple of stator pitches apart, so that the wake of one probe does not fall on the wake of another probe. Metal plugs are provided for each mounting pad when they are not in use.

(4) Two mounting pads are used for touch probes to measure tip clearance. One is located near the top and the other near the bottom of the casing at each rotor blade row.

Hub.—The following are the special features of the hub.

(1) A rotating-frame traverse probe mechanism is located within the hub casing at the third stage, as shown in figure 12. This traverse mechanism has two actuators located 180° apart, and is capable of circumferential motion across two rotor pitches starting and ending at rotor mid-pitch. Each probe actuator is capable of moving the probe in both radial and yaw motion. Although the probe actuator is located at a fixed axial location, the probe measurements can be acquired at various axial locations within the rotor by using right-angle probe stems of varying length.

(2) The hub casing has two circumferential slots located 180° apart in the same axial plane as the actuators. Each slot can hold a total pressure rake in a fixed position and can provide for a continuously variable location across the pitch of the rotor blade. All the probes are mounted through the casing window and secured within the hub cavity.

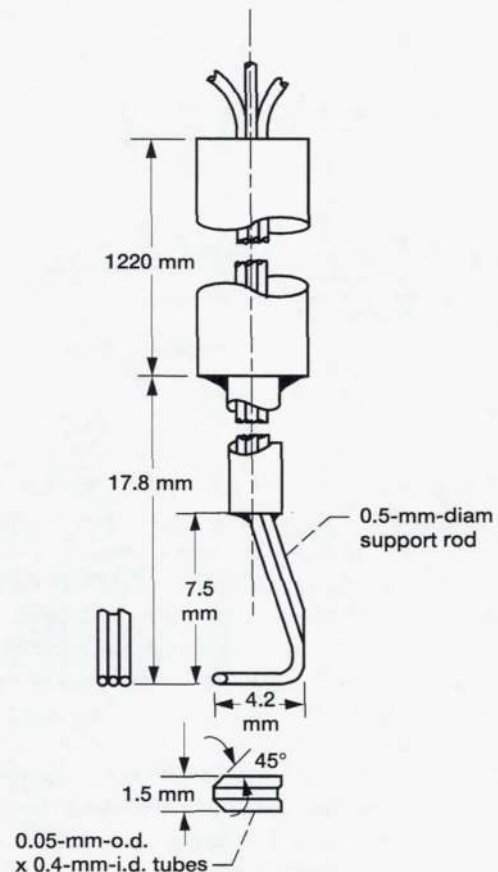

Figure 8.—Cobra probe.

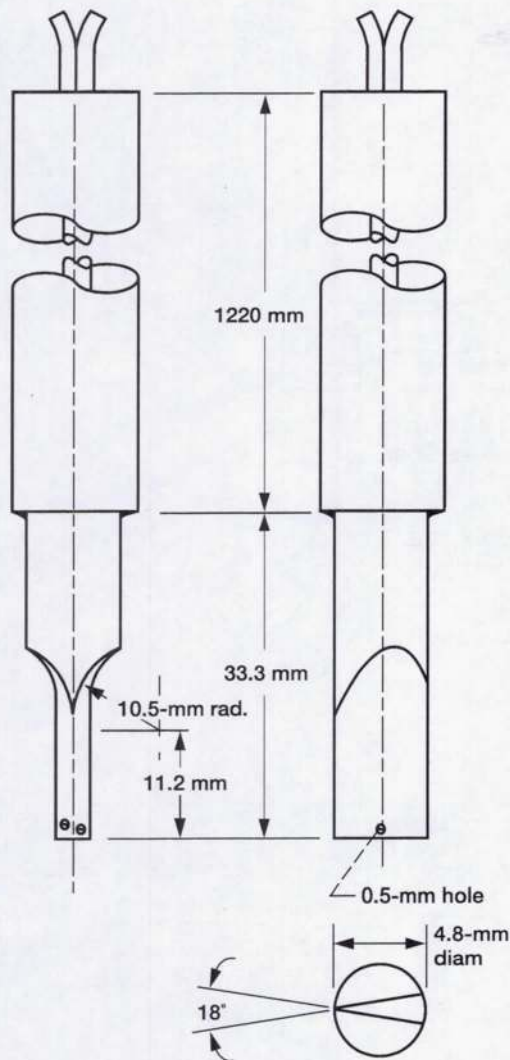

Figure 9.—Wedge probe.

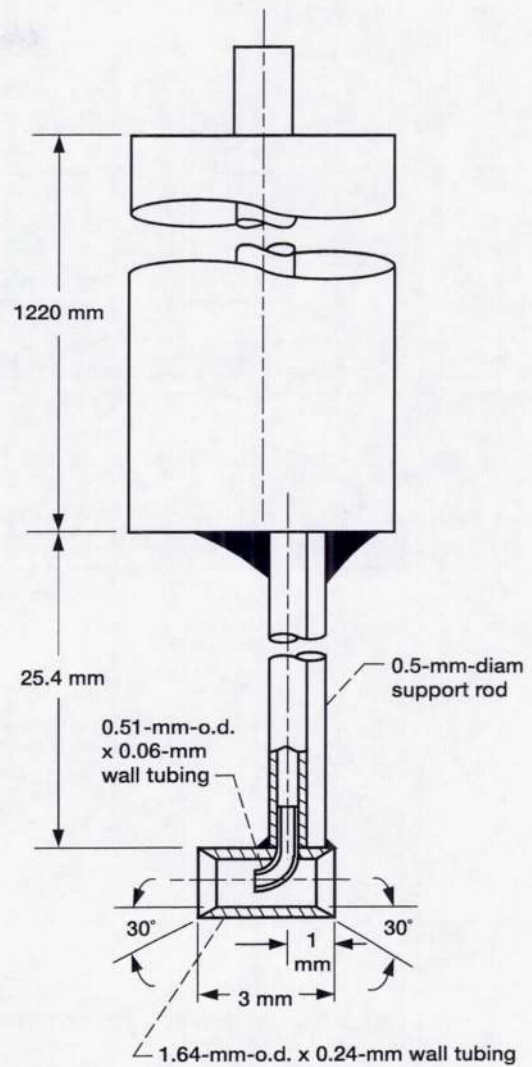

Figure 10.—Kiel probe.

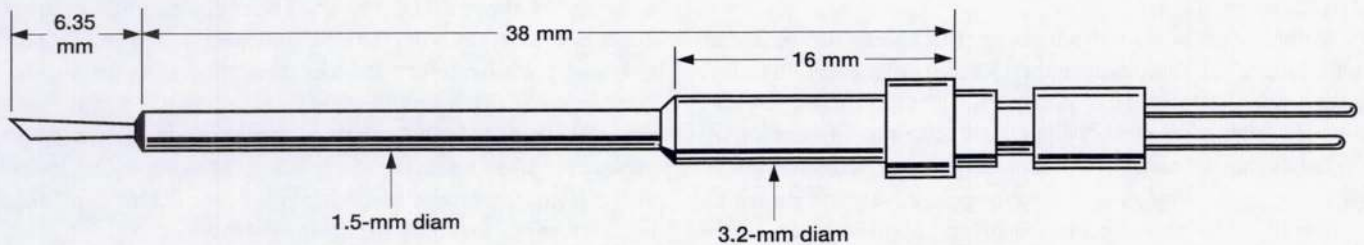

Figure 11.—Hot wire probe.

Instrumentation

Inlet.—From the bellmouth to the IGV's, there are a total of 21 static pressure taps in the outer casing and 20 in the centerbody wall. The IGV's have a total of 12 static taps: 4 at the inlet outer wall, 4 at the inlet inner wall, and 4 at the exit inner wall.

Stator.—There are 54 casing static pressure taps over all 4 stages. The rotating stator rings 1 and 2, have a total of 51 outer wall static taps; stator ring 3 has 36. In addition, there are 96 static taps in the footing platform and 12 in the footing cavity. Two aluminum stator blades at each station are instrumented with static taps. The suction surface of one blade has an array of 15 chordwise by 12 spanwise static taps, as shown

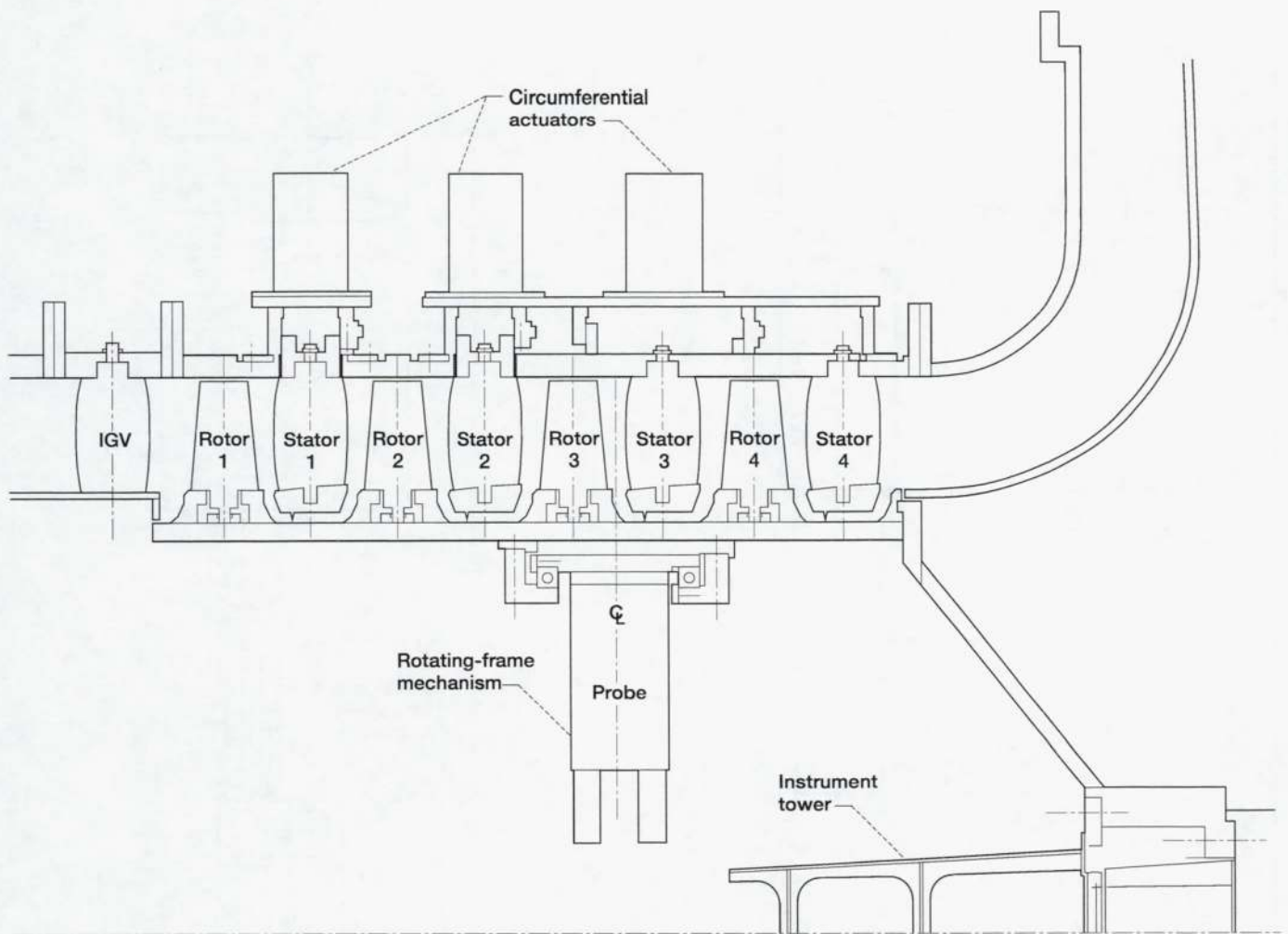

Figure 12.—Rotating-frame traverse probe mechanism and instrument tower.

in figure 13. The pressure surface on the opposite side of the passage has an array of 11 chordwise by 12 spanwise static taps (fig. 14). This gives a total of 312 stator blade surface static taps per station.

Rotor.—On the rotor drum at each rotor blade station, there are a total of 12 static taps in the footring cavity and 96 in the rotor blade platform. Two aluminum rotor blades at each station are instrumented with static taps. The suction surface of one blade has an array of 15 chordwise by 12 spanwise static taps (the same array as on the stator suction surface shown in figure 13). The pressure surface on the opposite side of the passage has an array of 11 chordwise by 12 spanwise static taps (the same array as on the stator pressure surface shown in figure 14). This gives a total of 312 surface static taps per station. In total, there are 54 static taps in the casing, 1424 in the stator ring, and 1398 in the rotor drum.

Stainless steel tubes from the static taps are routed inside the rotor drum to the ESP transducers on the instrument tower located at the end of the rotor shaft (fig. 12). The instrument tower holds four ESP transducers rated to 34.5 kN/m^2 and an absolute pressure transducer. The 4 ESP transducers provide

141 channels for rotating-frame pressure measurements from the hub static taps and the rotating probe mechanism. The four ESP transducers and the absolute transducer have a system accuracy of about $\pm 0.06 \text{ kN/m}^2$. The absolute pressure transducer is used to calibrate the ESP transducers during a research run. The pressure information is then relayed to the slip ring mechanism. Because of the centrifugal head effect of the air in the tubes produced by rotation, the pressure sensed by the pressure transducer on the tower is not the same as that located at the static tap on the blades or rotor drum. This centrifugal head effect is accounted for during data reduction.

In addition to blade static taps, one strain gage is mounted on each instrumented IGV blade and the third stage stator blade. The gage wires are routed through the blade base. Strain gage measurements are stored on magnetic tape for further processing.

Exit.—Forty static pressure taps are located in the annular diffuser section: 2 groups of 10 in the outer wall and 2 groups of 10 in the inner wall, both at circumferential locations spaced 180° apart at each streamwise location. These static taps are used to determine the flow quality within the diffuser.

TABLE II.—PROBE SURVEY
STATION LOCATIONS

Station	Axial position, m	Circumferential position, deg ^a
0.5	-0.167	6° 55' 117° 42'
1.0	.039	41° 09' 96° 32'
1.5	.183	55° 36' 97° 08'
2.0	.279	43° 50' 85° 22'
2.5	.376	55° 36' 104° 03'
3.0	.472	43° 50' 92° 00'
3.5	.569	271° 00'
4.0	.666	271° 00'
4.5	.762	41° 45' 97° 08'
5.0	.945	41° 09' 89° 03'

^aLooking downstream; top=0°

Special Instrumentation Features

The three windows in the casing (fig. 7) provide access for the flow visualization techniques, trace gas technique, and laser anemometry.

Flow visualization.—Fluorescent paint can be used on the blades and endwalls to show the flow within the boundary layer. The solid metal covers are used on the casing for these tests. After the test, the covers are removed and the blades and covers are illuminated with fluorescent (black) light and photographed to record the results.

Smoke can be injected ahead of each stage to visualize unsteady flows arising from blade row interactions within the compressor. Results may be recorded by using either a strobe light and fast frame camera, or a laser sheet and video recorder. Smoke is injected into the flow field through tubes fixed to the casing. Figure 15 shows the location of these tubes.

The ammonia vapor/ozalid paper technique can be used to determine the flow direction on the blade and endwall surfaces and to indicate regions of separated flow. Ozalid paper is attached to the surface of the blade of interest, just behind a row of static pressure taps. Ammonia gas is introduced through the static pressure taps, while the compressor is rotating, to expose a streak on the ozalid paper. These streaks show the local flow angle on the blade. The ozalid paper is then removed and used as a record of the surface flows.

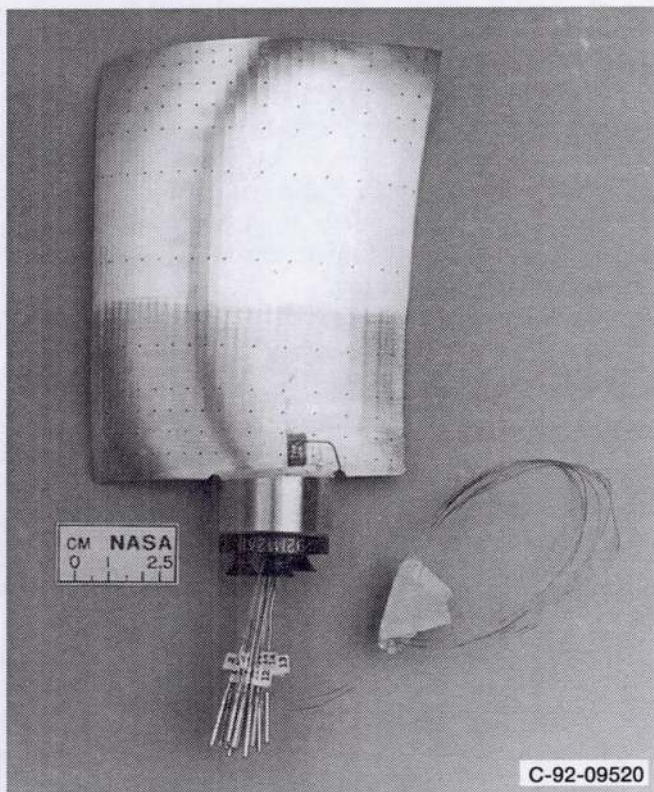

Figure 13.—Stator blade suction surface static taps.

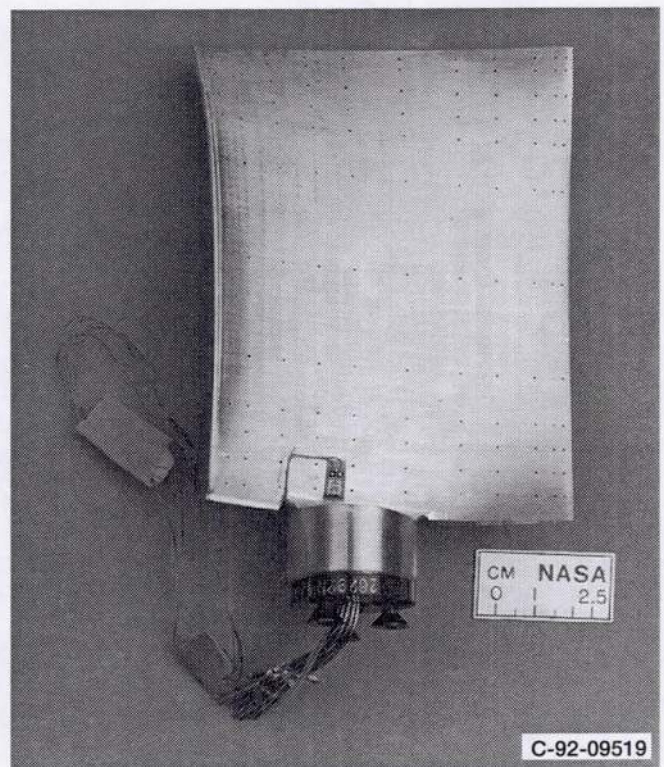

Figure 14.—Stator blade pressure surface static taps.

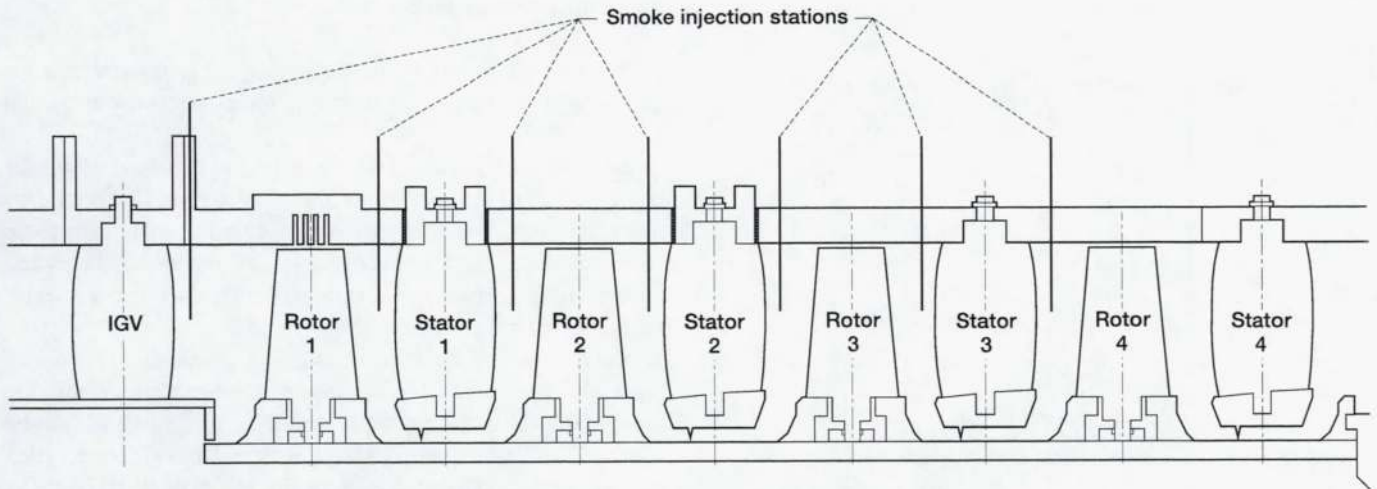

Figure 15.—Low-speed axial compressor smoke injection locations.

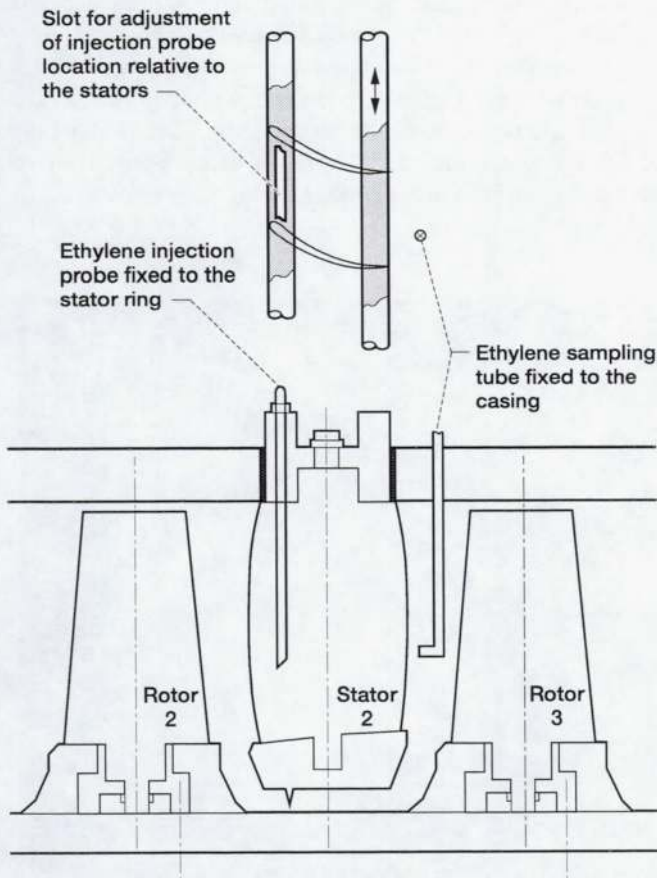

Figure 16.—Trace gas injection probes for stators 1, 2, and 3 (only stator 2 shown).

Trace gas technique.—The trace gas sampling technique involves injecting a small amount of ethylene gas into the flow field at a given radial location through a sampling tube in the stator leading edge plane (fig. 16), or through static pressure taps in the stator blade surfaces. The ethylene gas concentration is measured at locations downstream of the injection point. A continuous sample of gas is drawn from the flow field using a vacuum pump attached to a sampling tube; the sample is analyzed with a flame ionization detector.

Laser anemometry.—An argon-ion laser Doppler velocimeter (LDV) system can be used to obtain velocity measurements. The LDV system is mounted on translating tables (i.e., slides) to provide motion in the X-, Y-, and Z-directions. A dedicated minicomputer is used both to control the table drivers (positioning the system to predetermined measuring points), and to automatically record the data. Data are inspected on-line to determine acceptability and processed later for graphical presentation.

Concluding Remarks

A new, large multistage axial compressor was built at NASA Lewis Research Center for the Low-Speed Compressor Facility. It is primarily used to obtain detailed internal flow measurements. These measurements will be used to improve understanding of multistage compressor flow physics for flow physics modeling, and ultimately, to develop efficient performance prediction capabilities for both design and off-design

operating conditions. The compressor is heavily instrumented and has many features that provide the tools necessary for developing detailed models that describe the flow. Measurements can be made by using both standard aerodynamic probes and laser Doppler velocimetry. Flow visualization can be accomplished by using smoke, fluorescent paint, ammonia vapor/ozalid paper techniques, and trace gas sampling.

References

1. Wagner, J.H.; Dring, R.P.; and Joslyn, H.D.: Axial Compressor Middle Stage Secondary Flow Study. NASA CR-3701, 1983.
2. Bettner, J.L.; and Elrod, C.: The Influence of Tip Clearance, Stage Loading, and Wall Roughness on Compressor Casing Boundary Layer Development. ASME Paper 82-GOAO-153, Apr. 1982.
3. Wisler, D.C.: Core Compressor Exit Stage Study. NASA CR-165553, 1981.
4. Lakshminarayana, B.: An Axial Flow Research Compressor Facility Designed for Flow Measurement in Rotor Passages. *J. Fluids Eng.*, vol. 102, no. 4, Dec. 1980, pp. 402-411.
5. Hodson, H.P.; Huntsman, I.; and Steele, A.B.: An Investigation of Boundary Layer Development in a Multistage LP Turbine. ASME Paper 93-GOAO-310, May 1993.
6. Day, I.J.; and Freeman, C.: The Unstable Behavior of Low and High Speed Compressors. ASME Paper 93-GOAO-26, May 1993.
7. Wood, J.R.; Adam, P.W.; and Buggele, A.E.: NASA Low-Speed Centrifugal Compressor for Fundamental Research. NASA TM-83398, 1983.
8. Hathaway, M.D.; Wood, J.R.; and Wasserbauer, C.A.: NASA Low-Speed Centrifugal Compressor for Three-Dimensional Viscous Code Assessment and Fundamental Flow Physics Research. *J. Turbomach.*, vol. 114, no. 2, 1992, pp. 295-303.
9. Hathaway, M.D., et al.: Experimental and Computational Investigation of the NASA Low-Speed Centrifugal Compressor Flow Field. *J. Turbomach.*, vol. 115, no. 3, 1993, pp. 527-543.
10. Hathaway, M.D., et al.: Experimental and Computational Results From a Large Low-Speed Centrifugal Impeller. NASA TM-106421, 1993.
11. DeArmon, J.: PACS ELECTRONICS—Ax Motion System Manual for the Probe Actuator Control System. NASA Lewis Research Center, Cleveland, OH, 1993.
12. Fronek, D.L., et al.: A Distributed Data Acquisition System for Aeronautics Test Facilities. NASA TM-88961, 1987.

REPORT DOCUMENTATION PAGE

Form Approved
OMB No. 0704-0188

Public reporting burden for this collection of information is estimated to average 1 hour per response, including the time for reviewing instructions, searching existing data sources, gathering and maintaining the data needed, and completing and reviewing the collection of information. Send comments regarding this burden estimate or any other aspect of this collection of information, including suggestions for reducing this burden, to Washington Headquarters Services, Directorate for Information Operations and Reports, 1215 Jefferson Davis Highway, Suite 1204, Arlington, VA 22202-4302, and to the Office of Management and Budget, Paperwork Reduction Project (0704-0188), Washington, DC 20503.

1. AGENCY USE ONLY (Leave blank)	2. REPORT DATE July 1995	3. REPORT TYPE AND DATES COVERED Technical Memorandum	
4. TITLE AND SUBTITLE NASA Low-Speed Axial Compressor for Fundamental Research		5. FUNDING NUMBERS WU-505-62-52	
6. AUTHOR(S) Charles A. Wasserbauer, Harold J. Weaver and Richard G. Senyitko		8. PERFORMING ORGANIZATION REPORT NUMBER E-9016	
7. PERFORMING ORGANIZATION NAME(S) AND ADDRESS(ES) National Aeronautics and Space Administration Lewis Research Center Cleveland, Ohio 44135-3191		10. SPONSORING/MONITORING AGENCY REPORT NUMBER NASA TM-4635 <i>Corrected copy</i>	
9. SPONSORING/MONITORING AGENCY NAME(S) AND ADDRESS(ES) National Aeronautics and Space Administration Washington, D.C. 20546-0001		11. SUPPLEMENTARY NOTES Charles A. Wasserbauer and Richard G. Senyitko, Sverdrup Technology, Inc., Lewis Research Center Group, Brook Park, Ohio, (work funded by NASA contract NAS3-25266), presently at NYMA, Inc., Engineering Services Division, 2001 Aerospace Parkway, Brook Park, Ohio 44142; and Harold F. Weaver, NASA Lewis Research Center. Responsible person, Charles A. Wasserbauer, organization code 2840, (216) 433-5709.	
12a. DISTRIBUTION/AVAILABILITY STATEMENT Unclassified - Unlimited Subject Category 09		12b. DISTRIBUTION CODE	
13. ABSTRACT (Maximum 200 words) A low-speed multistage axial compressor built by the NASA Lewis Research Center is described. The purpose of this compressor is to increase the understanding of the complex flow phenomena within multistage axial compressors and to obtain detailed data from a multistage compressor environment for use in developing and verifying models for computational fluid dynamic code assessment. The compressor has extensive pressure instrumentation in both stationary and rotating frames of reference, and has provisions for flow visualization and laser velocimetry. The compressor will accommodate rotational speeds to 1050 rpm and is rated at a pressure ratio of 1.042.			
14. SUBJECT TERMS Multistage axial compressor; Rotating stator ring; Instrumented blades; Low-speed aerodynamics		15. NUMBER OF PAGES 13	
17. SECURITY CLASSIFICATION OF REPORT Unclassified		16. PRICE CODE A03	
18. SECURITY CLASSIFICATION OF THIS PAGE Unclassified	19. SECURITY CLASSIFICATION OF ABSTRACT Unclassified	20. LIMITATION OF ABSTRACT	