

Nature of the Transition Between Two Modes of External Space Perception in Tilted Subjects

Ronald G. Kaptein and Jan A. M. Van Gisbergen

Department of Biophysics, Institute for Neuroscience, Radboud University Nijmegen, Nijmegen, The Netherlands

Submitted 4 November 2004; accepted in final form 20 January 2005

Kaptein, Ronald G. and Jan A. M. Van Gisbergen. Nature of the transition between two modes of external space perception in tilted subjects. *J Neurophysiol* 93: 3356–3369, 2005. First published January 26, 2005; doi:10.1152/jn.01137.2004. A striking feature of visual verticality estimates in the dark is undercompensation for lateral body tilt. Earlier studies and models suggest that this so-called Aubert (A) effect increases gradually to around 130° tilt and then decays smoothly on approaching the inverted position. By contrast, we recently found an abrupt transition toward errors of opposite sign (E effect) when body tilt exceeded 135°. The present study was undertaken to clarify the nature of this transition. We tested the subjective visual vertical in stationary roll-tilted human subjects using various rotation paradigms and testing methods. Cluster analysis identified two clearly separate response modes (A or E effect), present in all conditions, which dominated in different but overlapping tilt ranges. Within the overlap zone, the subjective vertical appeared bistable on repeated testing with responses in both categories. The tilt range where bistability occurred depended on the direction of the preceding rotation (hysteresis). The overlap zone shifted to a smaller tilt angle when testing was preceded by a rotation through the inverted position, compared with short opposite rotations from upright. We discuss the possibility that the A-E transition reflects a reference shift from compensating line settings for the head deviation from upright to basing them on the tilt deviation of the feet from upright. In this scenario, both the A and the E effect reflect tilt undercompensation. To explain the hysteresis and the bistability, we propose that the transition is triggered when perceived body tilt, a signal with known noise and hysteresis properties, crosses a fixed threshold.

INTRODUCTION

When tilted in the dark, subjects make systematic errors in judging visual line orientations with respect to gravity. Most previous studies have reported that these errors in the subjective visual vertical are compatible with tilt underestimation (Aubert or A effect) for roll tilts beyond 60° (see Fig. 1). For smaller tilts, errors of opposite sign (Müller or E effect) may be found (for a review, see Howard 1982, 1986). Systematic errors in the perception of body tilt are generally much smaller, suggesting that errors in visual orientation perception are not simply due to an inaccurate head-orientation-in-space signal (see Jaggi-Schwarz and Hess 2003; Kaptein and Van Gisbergen 2004; Mittelstaedt 1983).

According to classical accounts (Mittelstaedt 1983; Schöne 1964; Van Beuzekom and Van Gisbergen 2000), the A effect peaks near 130° tilt and then gradually decays toward 0 in the inverted position. However, in a recent study (Kaptein and Van Gisbergen 2004), we found a collapse of the A effect at tilts beyond ~135° to errors of opposite sign (E effect, see Fig. 1),

suggesting the presence of two response modes at large tilt. It should be emphasized that the sudden transition was not the expression of deteriorating performance at large tilts. In fact, systematic errors were much smaller after the collapse.

The major objective of the present study was to establish the nature of the transition. Three possibilities can be envisaged. One is that the transition conforms to a single-valued but discontinuous function as suggested in Kaptein and Van Gisbergen (2004). Our earlier data cannot rule out, however, that the transition actually follows a steep but smooth continuous function. The third possibility is that the response in the critical zone cannot be described by a single-valued function. This applies to the case of a bistable system, which can give rise to either of two distinct response modes at a given tilt angle, a possibility that has been mentioned anecdotally in the literature (Fischer 1930; Schöne 1964; Udo de Haes and Schöne 1970). Settling these issues requires an extensive data set. With this in mind, the original data set (Kaptein and Van Gisbergen 2004) was expanded considerably by taking repeated measurements of the subjective visual vertical and by testing at more closely spaced tilt angles. To test whether the transition shows signs of bistability on a short time scale, we also used a different testing method that allowed us to obtain multiple responses within one trial.

Our second goal was to clarify why this transition from A to E effect responses has virtually escaped previous investigations in this field. Most earlier studies only used a 180° rotation range, which means that rightward rotations never led to a leftward final tilt. This provided a degree of prior knowledge that was not present in our previous study. Therefore we explored whether using the more common 180° range of rotations, instead of the 360° range in our previous investigation, would affect the results. We also tested whether our use of a polarized luminous line, which is not generally adopted, may have been a factor.

Our new data, showing two clearly separated response modes (A and E), firmly rule out the continuous function hypothesis. We explain how the seemingly odd error reversal in the A-E transition may represent a shift in an internal reference used when adjusting line settings for sensed body tilt. We present indirect evidence that the two distinct response modes are indeed linked to different computational strategies. A major new finding is that the location of the transition along the tilt axis depends on the direction of the preceding rotation. A quantitative analysis of this hysteresis effect suggests that perceived body tilt may trigger the response shift. Noise in the

Address for correspondence: R. G. Kaptein, Dept. of Biophysics, Radboud University Nijmegen, Geert Grootplein 21, 6525 EZ Nijmegen, The Netherlands (E-mail: r.kaptein@science.ru.nl).

The costs of publication of this article were defrayed in part by the payment of page charges. The article must therefore be hereby marked "advertisement" in accordance with 18 U.S.C. Section 1734 solely to indicate this fact.

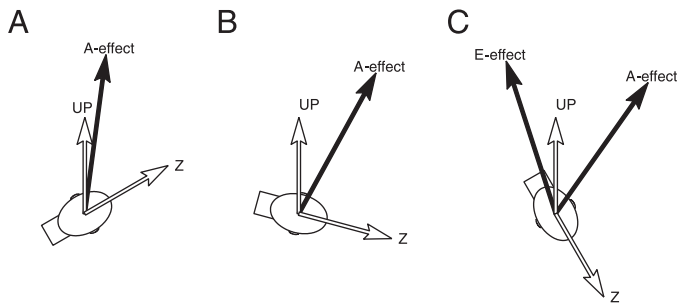

FIG. 1. Schematic illustration of systematic errors in the subjective vertical. The 3 diagrams show roll tilts of 60, 105, and 150°, from left to right. Z indicates the orientation of the body axis, seen from behind. The arrow labeled A effect shows the typical increase of the A effect with tilt angle, according to classical accounts. Comparison with the required response (UP) shows that the A effect represents a bias toward the subject's z axis. Kaptein and Van Gisbergen (2004) recently found an abrupt transition from an A to an E effect at large tilts ($\geq 135^\circ$) that is indicated in the right-hand figure.

trigger signal is held responsible for scatter in the tilt angle where the transition occurs and for the resultant signs of bistability that were found on repeated testing. Results from the commonly used 180° rotation paradigm showed similar phenomena at higher tilt angles. The fact that this made the transition less conspicuous may explain why these phenomena have been overlooked in earlier studies.

METHODS

Vestibular rotation paradigms

The subject was seated in a computer-controlled vestibular stimulator. Body tilt was controlled by rotation about the naso-occipital roll axis at a constant velocity of 30°/s. Roll position was measured using a digital position encoder with an angular resolution of 0.04°. The cyclopean eye was aligned with the axis of rotation by adjusting the subject's seat in height. The subject's trunk was tightly fixated using seat belts and adjustable shoulder and hip supports. The legs and feet were restrained by Velcro straps. The head was firmly fixated in a natural upright position for looking straight ahead, using a padded helmet.

Rotation always started from upright and alternated between clockwise (CW) and counterclockwise (CCW), defined as if seen from behind the subject. An important objective of the present study is to investigate whether there may be other factors in the vestibular rotation paradigm, besides final tilt angle, that affect the subjective visual vertical. One such potential factor is the rotation trajectory toward the final position where testing took place. For example, as illustrated in Fig. 2A, the subject can be brought into the 120° right-ear down position (starting from the upright position) either by the short-path rotation (120° CW) or by a long-path rotation (i.e., 240° CCW) in opposite direction.

In our main experiment, we used both short- and long-path rotation trajectories for each final tilt angle. As a consequence, the rotation range was 0–360°, just as in Kaptein and Van Gisbergen (2004), so that there was no fixed relation between the direction of rotation and the orientation of the final tilt angle. Because short- and long-path rotations were alternated in random order, subjects had no cue whatsoever about the final tilt angle in the forthcoming trial. The experiment was designed to compare the results of both rotation paradigms for each final tilt angle.

With rare exceptions, previous investigations of the subjective visual vertical have exclusively relied on short-path rotations so that the rotation range never exceeded 180°. With this more restricted stimulus ensemble, a degree of prior knowledge about the forthcoming trial is unavoidable. For example, a rightward rotation will never

result in a leftward final tilt angle. To check whether this might affect the results, we ran a separate set of control experiments in which we presented the same set of short-path rotations in isolation, thereby restricting the rotation range to 0–180° (see *Experiments*). With this rotation paradigm, subjects reached their final tilt angle without ever crossing the inverted position. Before the experiment began, subjects were informed about the maximum rotation range that would be used.

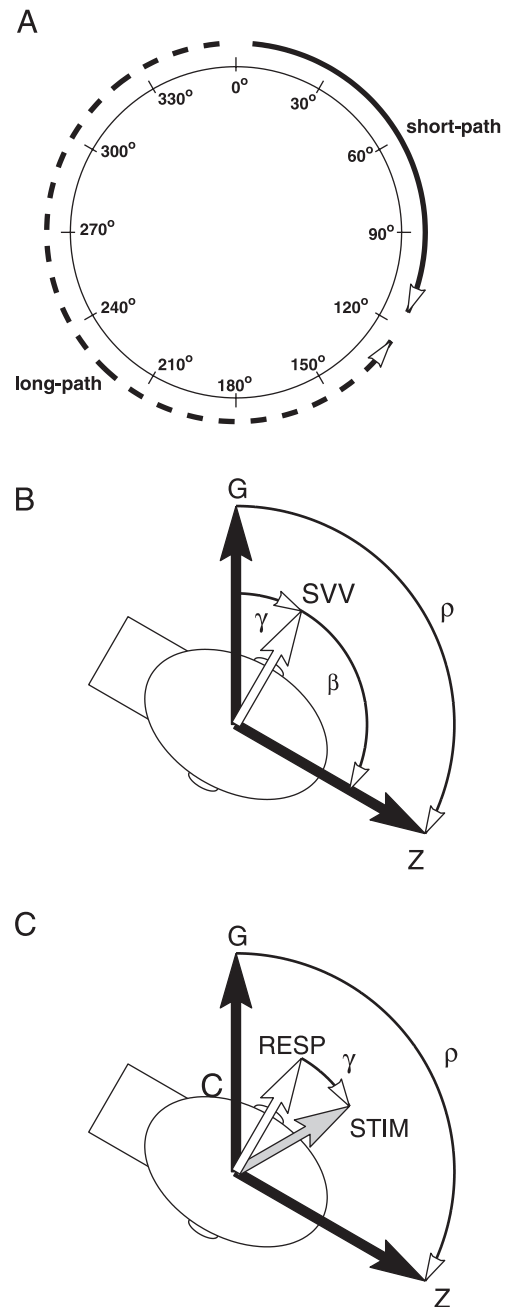

FIG. 2. Definition of angles and rotations with subject in rear view. Tilt position (ρ) is 120° in all panels. A: the 2 possible rotations to reach this tilt position, starting from upright. Numbers denote the ρ scale (0–360°). In experiments using the adjustment method (B), response error (γ) was defined as the true vertical (G) minus the subject's line setting to the subjective visual vertical (SVV). Clockwise (CW) deviations were taken positive. β : the line setting relative to the subject's head axis (Z). Tilt angle is denoted by ρ . In the flashed-line paradigm (C), response error was defined as estimated (RESP) minus actual line (STIM) orientation, now with counter clockwise (CCW) deviations defined positive. With these conventions, performance in the 2 types of experiments can be directly compared.

Irrespective of the rotation range used in the experiment, testing of the subjective visual vertical occurred at 30° intervals $\leq 120^\circ$ absolute tilt (0, 30, 60, 90, 120°). Absolute tilt is defined as the net deviation in tilt angle from the upright position. To get a detailed picture of the abrupt transition in response mode described previously, we used finer sampling, at 10° intervals, for larger absolute tilts (130, 140, . . . , 170, 180). In part of the experiments, some scatter (max $\pm 10^\circ$) was superimposed on these final tilt positions. Testing of the various tilt angles occurred in random order.

After the rotation to the final tilt angle of a given trial had been completed, 30 s elapsed before testing began to allow putative canal aftereffects to wear off. After completion of the trial, the subject was rotated back to the upright position where he remained for 60 s, with the room lights on, until the next trial began. Vision was always binocular and subjects were allowed to move their eyes freely.

Subjects

Five subjects, all male, gave informed consent to participate in the experiments. Three of them had knowledge about the purpose of the experiments (*RK*, *JG*, and *RV*) and two of them were naive (*SP* and *GE*). Because the experiments required many sessions, it was not feasible to include more naive subjects. However, because the results show no differences between the naive and nonnaive subjects, it is unlikely that this has influenced our results. Age ranged from 23 to 60, with an average of 31 ± 15 (SD) yr. Four of the subjects also participated in the previous study (Kaptein and Van Gisbergen 2004), subject *SP* did not.

Before the experiment began, subjects were carefully instructed about the forthcoming task and were given a few practice runs to get used to the experiment. Subjects never received feedback about their performance. They were instructed that they could terminate the experiment at any moment, if they wished.

Various testing methods of the subjective visual vertical

To test the subjective visual vertical, we used a luminous line with an angular subtense of 20° that was mounted at 90 cm in front of the subject. Its rotation axis coincided with the roll axis of the subject. With the exception of one control experiment, where the line was nonpolarized, the luminous line had the polarized appearance of an exclamation mark. In the course of the experiments, we used two different methods for recording the subject's sense of verticality: the method of adjustment and a scaling method.

METHOD OF ADJUSTMENT. In most experiments, the task of the subject was to adjust the line, which remained visible for 30 s, to the direction of gravity with the dot pointing upward. In the nonpolarized line experiment, the subject was merely asked to set the line parallel to the perceived direction of gravity. The line could be adjusted back and forth by means of a joystick mounted near the subject's right hand. Trials not completed within the 30-s time window were discarded and repeated later. The line could be set with an angular resolution of $\sim 0.5^\circ$ and its final setting was stored on disk.

SCALING METHOD USING FLASHED-LINE PRESENTATIONS. A separate series of experiments was designed to allow rapid sampling of the subjective visual vertical, to capture its fluctuations within the time scale of a single trial (30 s). Because the adjustment paradigm was too sluggish for this purpose, these data were collected by flashing the polarized line in a series of 12 random orientations to be judged on a clock scale. Further details of this experiment will be provided in the next subsection.

Experiments

The description of the experiments has been subdivided into two main categories based on the method that was used to determine the subjective visual vertical (adjustment vs. scaling method).

EXPERIMENTS RELYING ON ADJUSTMENT METHOD. As explained in the INTRODUCTION, one purpose of the present study was to expand the existing data set by extended testing at more closely spaced tilt angles. A further objective was to test whether certain aspects of the experimental approach, which set our previous study somewhat apart from what has become customary, might account for our finding of the transition from A to E effect at large tilt. Details of the experiments, undertaken with these purposes in mind, will now be summarized.

Standard 360°-range experiment. This paradigm was also used in our previous study (Kaptein and Van Gisbergen 2004). Starting from upright, subjects were rotated in roll between 0 and 360°, CW or CCW, to a final tilt angle randomly selected out of the predetermined array specified in the preceding text. Thus the final tilt angle might be reached by either a long- or a short-path rotation (see Fig. 2A). In subject *SP*, who had not participated in the earlier study, these experiments were necessary for comparison with the control experiments described in the following text. Three of the four subjects (*RK*, *JG*, and *RV*), who had participated in our previous study, underwent additional testing in this paradigm to obtain a larger number of responses at a given tilt angle and to obtain finer sampling. Subjects in the present study adjusted the polarized luminous line with a joystick. This replaced the more indirect method used in the previous study without any noticeable effect on the results. On average, five sessions of 45 min were used to expand the data set in subjects *RK*, *JG*, and *RV*. Four such sessions were used for *SP*.

Limited 180°-range control experiment. The same set of final tilt angles as in the standard paradigm was tested using the same polarized line and the same method of adjustment. As in most studies reported in the literature, only short-path rotations were used. The question behind this control experiment was whether this difference could account for the fact that the transition from A to E effect at large tilt was never reported as a robust finding in the literature. This paradigm was tested in five subjects, two of whom were naive with respect to the purpose of the experiment. However, all subjects were informed that the maximum rotation in the forthcoming experiment would never exceed 180°. Two to three 45-min sessions were needed to collect the data from each subject.

Nonpolarized line control experiment. The rotation range was 0–360°, just as in the standard paradigm. The only difference was the use of a nonpolarized line, lacking the dot on one end. The subject was asked to set the line parallel to the direction of gravity using the joystick. The question behind the experiment was whether our use of a polarized luminous line might have been a factor in the response transition at large tilt. A total of three subjects participated in this experiment, none of them being naive. Approximately five sessions of 45 min were used to collect the data from each subject.

EXPERIMENT RELYING ON SCALING METHOD. The purpose of this experiment was to gain a better understanding of the stochastic dynamics of the A to E effect transition. Because this required a rapid method that allowed a quick succession of independent tests within one trial, we used the flashed-line method introduced by Van Beuzekom et al. (2001).

Flashed-line experiment. Subjects were rotated between 0 and 360°, CW or CCW, toward the same set of final tilt angles as tested in the standard 360°-range experiment described in the preceding text. After the 30-s waiting period, the polarized line was flashed briefly for 2 ms at intervals of 2.5 s. After each flash, the line changed orientation so that a total of 12 lines with different orientations were presented during 30 s. The subject was asked to judge the orientation of this line in world-fixed coordinates, using a clock scale (see also Van Beuzekom et al. 2001). Subjects were instructed to imagine a clock hanging in front of them on the wall of the room and to judge the line's orientation on this clock. For example, a response of 12 o'clock would mean 0° (upward) and 15 min past the hour would be 90°. Subjects mostly used 1-min accuracy but sometimes half minutes were used. By presenting many different line orientations in random

order, subjects were forced to make independent judgments and merely repeating memorized previous responses was prevented. The subject's verbal responses were listed by the experimenter and re-recorded on audio tape to allow checking afterwards. Sometimes the response was unintelligible. Sometimes the subject did not respond because of the quick succession or the short duration of the flashed lines. These causes led to a loss of $\sim 2\%$ of the responses. Four subjects participated in this paradigm, one of them (SP) being naive. Approximately six sessions of 45 min each were needed to collect the data from each subject.

Data analysis

DEFINITION OF ANGLES. Following the same conventions as in Kaptein and Van Gisbergen (2004), tilt position ρ denotes the final angular head position (see Fig. 2) which can vary along a scale spanning the range 0 to 360°, with 0° (and 360°) denoting the upright position. To avoid misunderstanding, it should be emphasized that ρ (see scale in Fig. 2A) has nothing to do with the rotation (short or long path) used to reach that tilt position. Figure 2A depicts how a $\rho = 120^\circ$ tilt position can be accomplished by a 120° CW or a 240° CCW rotation.

The deviation from upright will be denoted "absolute tilt," using a 0–180° scale. Figures showing tilt-dependent responses will be labeled using both ρ and absolute tilt, where 90R and 90L indicate 90° right-ear down and 90° left-ear down, respectively.

In all experiments using the adjustment paradigm, response error, to be denoted by γ , was defined as the difference between the line setting and the true vertical. Luminous line settings in the CW direction, seen from behind the subject, were taken positive (Fig. 2B). Accordingly, an A effect during rightward tilt yields a positive γ , an A effect during leftward tilt ($\rho > 180^\circ$) reflects a negative γ .

In the flashed-line experiments, γ equaled the estimated orientation minus the presented orientation with CCW deviations being defined positive (Fig. 2C). These definitions allowed a direct comparison of response errors, irrespective of which scoring method (adjustment or scaling) was used to assess performance.

CLUSTER ANALYSIS. To check whether the subjective impression of two distinct response modes in the transition zone would stand the test of scrutiny, we performed a cluster analysis on the data. We applied the hierarchical clustering method implemented in the "linkage" algorithm (Matlab 6.0; The Mathworks) using a standardized Euclidian metric and an average distance measure. The algorithm served to delineate the two major clusters in error-tilt scatter plots objectively. For comparison, we also performed K-means clustering, using the routine "kmeans" (Matlab 6.0; The Mathworks) with $k = 2$. To verify whether the underlying assumption of a bimodal response distribution applied, we used the nonparametric dip test of unimodality (Hartigan 1985; Hartigan and Hartigan 1985), as implemented in the "dip test" algorithm of the R statistical package (version 1.9.1) (R Development Core Team 2004). Statistical results were considered significant if $P < 0.05$.

NONLINEAR-FUNCTION FITS. In the DISCUSSION, we fitted a quadratic function to the A cluster in a least-square sense. The coefficient a is defined according to $Y = a \cdot X^2$, where X represents absolute tilt. The SD was determined with the bootstrap method (Press et al. 1992).

To describe how the proportion of E cluster responses in the A-E transition zone increased gradually with tilt angle, we used a cumulative distribution function $P_E(\rho)$ defined as

$$P_E(\rho) = \frac{1}{\sigma\sqrt{2\pi}} \int_0^\rho e^{-\frac{(\rho' - \rho_t)^2}{2\sigma^2}} d\rho' \quad (1)$$

In this expression, $P_E(\rho)$ represents the fraction of E responses as a function of tilt angle. Parameter ρ_t can be interpreted as the mean tilt

angle where the transition occurs and σ reflects the scatter in this tilt angle.

The best-fit curves (see Fig. 7) were obtained with the maximum likelihood method using a binomial distribution for each tilt position. This means that for each tilt position, the distribution of A and E responses was taken to be binomial, with the probability of getting an E response given by P_E (see Eq. 1) and the probability of an A response by $1 - P_E$. The best-fit values for ρ_t and σ are those that maximize the total likelihood. This maximization was done by minimizing the negative log-likelihood, using the Nelder-Mead algorithm as implemented in "fminsearch" (Matlab 6.0; The Mathworks). See Wichmann and Hill (2001) for more details. Standard deviations of the parameters were determined with the bootstrap method.

RESULTS

Overview of results from control experiments

Recently, we found an unexpected transition from A to E effects at large tilt angles (Kaptein and Van Gisbergen 2004). The major objective of this study was to establish the nature of the transition and to find out whether it can be categorized as continuous, discontinuous, or bistable. A further goal was to understand why the transition has not been reported in the earlier literature. To resolve these issues, we first determined the subjective visual vertical in three different experimental paradigms, all relying on the adjustment method and all testing the same set of final tilt angles.

Figure 3, A–C, shows the pooled population results from three adjustment experiments: the 360° polarized-line paradigm (A), the 180° polarized-line paradigm (B), and the 360°

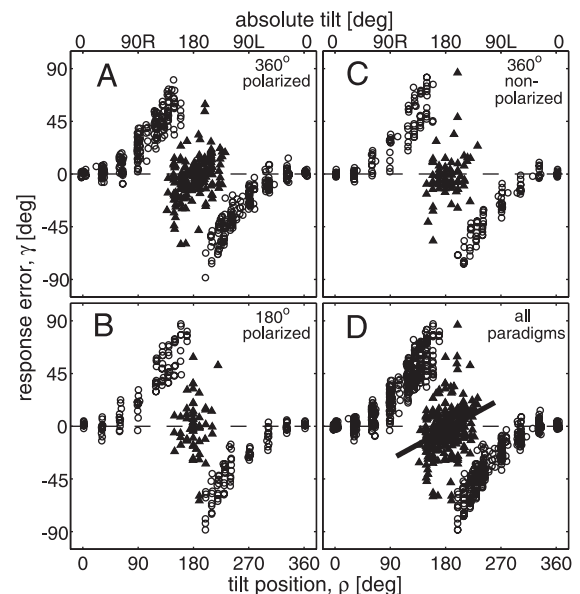

FIG. 3. Comparison of results from different rotation and adjustment paradigms. *A*: 360° polarized-line paradigm. *B*: 180° polarized-line paradigm. *C*: 360° nonpolarized-line paradigm. *D*: pooled across paradigms. In *A*, *C*, and *D*, short- and long-path rotations were pooled; *B* only contains short-path rotation data. In all paradigms, there is a clear A effect that dominates in the range up to $\sim 135^\circ$. At larger tilts, a 2nd response type emerges, where systematic errors are smaller and mostly of the E-type. Different symbols show the result of the cluster analysis. \circ , A-cluster trials; \blacktriangle , E-cluster trials. The tilt range where the E effect occurs in the 180° paradigm (*B*) seems more restricted. Wilcoxon rank-sum tests showed that the tilt relations of the A and E clusters show no paradigm-related differences. The — in *D* shows the result of a linear regression on the E cluster. Best-fit parameters are: slope: 0.29 ± 0.05 ; offset: -54 ± 8 ; $R = 0.33$; $P < 0.0001$; $n = 311$.

nonpolarized line experiment (*C*). Each graph plots response error, measured in individual trials, as a function of final tilt angle. The two different symbols represent the results of the clustering analysis that will be presented in the next section (see *Identification of two distinct response modes by cluster analysis*). In *A* and *C*, short- and long-path rotation results have been pooled. Of course, *B* only shows responses to short-path rotations.

According to classical descriptions of the subjective visual vertical (Mittelstaedt 1983; Schöne 1964), *A* effects show a gradual increase for absolute tilts beyond $\sim 60^\circ$ to a peak near 130° and then decay smoothly back to zero at 180° tilt. Responses with errors of opposite sign (*E* effect), if present at all, would be limited to small tilt angles. The large-tilt data in Fig. 3 clearly do not conform to this classical picture at all.

To start with the results from the 360° polarized-line paradigm (Fig. 3*A*), we see a dramatic collapse of the *A* effect at large tilt in the form of a reset-type of transition toward much smaller errors, mostly of the *E*-type. While this result firmly corroborates the earlier findings described in Kaptein and Van Gisbergen (2004), the much larger data set now available reveals interesting additional features that were not apparent previously. It is now clear that the transition is not continuous, because there is a clear separation into two response clusters. Along the horizontal tilt axis, the *A*-*E* transition is less abrupt than previously suggested. Instead of a well-defined critical tilt angle, marking a sharp boundary that assigns the two response modes to adjacent tilt domains, there now appears to be a tilt range where both responses overlap. This suggests that the subjective visual vertical percept may be locally bistable. Because these are pooled data, caution is warranted so that it is important to check whether the notion of a bistable tilt range is upheld in data from individual subjects. This topic will be taken up again later (see *Analysis of the transition zone*).

Inspection of the results from the two control experiments (Fig. 3, *B* and *C*) immediately shows a strong resemblance to the results in *A*. The results of the 180° rotation paradigm (Fig. 3*B*) also exhibit an indication of two response modes. Again there is an indication of a bistable region where the two modes overlap, but this zone now seems shifted to higher tilt angles and the *E*-zone is more restricted. This latter aspect will be subjected to closer analysis later on.

Results from the nonpolarized line paradigm, shown in Fig. 3*C*, also feature the same signs of two response modes and indications of bistability at certain tilt angles, roughly similar to the response pattern in Fig. 3*A*. Because the 360° nonpolarized line data are so similar to those from the standard 360° paradigm, obtained with a polarized line, we conclude that this factor is irrelevant for the explanation of our results. Therefore the 360° polarized and nonpolarized line results were pooled for further analyses.

In conclusion, the consistent finding of bimodal response patterns in all three paradigms suggests that the *A*-*E* transition is a genuine characteristic of the system rather than a curiosity of particular experimental conditions. At the same time, this finding also rejects any notion that the transition could be described by a continuous function. That the *E* effect range seems more restricted in the 180° paradigm, an interesting fact in itself, may help to explain why this phenomenon has been overlooked in earlier studies (see *DISCUSSION*).

Identification of two distinct response modes by cluster analysis

APPROACH CLUSTER ANALYSIS. Closer inspection of the error-tilt scatter plots in Fig. 3, *A*–*C*, suggests several potential relationships that deserve further analysis: 1) the large-tilt responses in both paradigms suggest a dichotomy, characterized by two major clusters with different modes; 2) with increasing tilt angle, there appears to be a gradual shift in the probability of obtaining either one or the other response, implying the existence of an intermediate tilt zone with bistable behavior; and 3) differences in rotation paradigm seem to affect the expression of this stochastic process (cf. Fig. 3, *A* and *B*).

In an attempt to substantiate the notion of two major response modes, we performed a statistical cluster analysis (see *METHODS*). This analysis explored the hypothesis that there are two major potential response modes at large tilts with invariant properties across subjects and rotation paradigms (180 vs. 360°). According to this concept, subject and paradigm-related differences in performance reflect probabilistic differences determining which of the two invariant response modes prevails. If this hypothesis is correct, the error-tilt relation dictated by each response mode is paradigm independent.

To explore whether the notion of two paradigm-invariant response modes is a plausible concept, the clustering analysis was performed on the combined adjustment data from all three paradigms in Fig. 3*D*, thus imposing a common set of criteria on the pooled data. The data set obtained in this fashion contained the responses from 1,063 trials in five subjects. Because we pooled responses from both the 360 and the 180° paradigm, the data set includes both short- and long-path rotation trials. Because there was no reason to suspect a left-right asymmetry in the system, the data from left- and rightward tilts were pooled as well. The actual cluster analysis, performed in two dimensions, was limited to the data associated with absolute tilts $>120^\circ$, the range where the response dichotomy comes to expression.

IDENTIFICATION OF *A*- AND *E*-RESPONSE CLUSTERS IN ADJUSTMENT DATA. The results obtained with two different clustering algorithms (hierarchical clustering and K-means clustering, see *METHODS*) were in very good mutual agreement. The description of the clustering results will concentrate on the two clusters uppermost in the hierarchy detected by the hierarchical clustering method. This is consistent with our objective: to find an objective basis for delineating two major clusters in the error-tilt relation scatter plots. The two major clusters detected by the hierarchical clustering algorithm are shown in Fig. 3*D* by two different symbols. Despite the extensive data pooling across subjects, paradigms and tilt direction, the two clusters stand out very clearly. This robustness of the result lends some credibility to the notion that there are two major response modes with broad validity across subjects and experimental conditions.

Because of their association with large *A* effects (\circ) and with *E* effects at large tilts (\blacktriangle), the two clusters in Fig. 3*D* will be dubbed *A* cluster and *E* cluster, respectively. These terms serve as easily memorized short labels, to simplify description. It should be kept in mind, however, that there are trials where this label is incorrect in a strict sense, especially in the *E* cluster where some trials show a small *A* effect. Because the data collected at tilts $<120^\circ$ form a continuum with the *A* cluster,

these trials will be denoted as A trials as well. Cluster analysis is an objective procedure for distinguishing two clusters but gives no easily interpreted statistical measure for their separation. We applied the nonparametric dip test (see METHODS) to test whether distinguishing two clusters was justified. When applied to the error distribution obtained by pooling all data with absolute tilt $>120^\circ$ in the data set of Fig. 3D ($n = 574$), the dip test rejected the null hypothesis that the distribution is unimodal ($P < 0.001$). To illustrate that there is a clear dip between the two major modes of the error distribution, Fig. 4A shows a histogram of all the adjustment data with absolute tilt $>120^\circ$. The distribution is clearly bimodal, with peaks around -5 and 50° . Application of the dip test on the adjustment data of single subjects showed that the deviation from a unimodal error distribution was significant ($P < 0.01$) in four of the five subjects. In *subject GE*, this was not the case ($P = 0.13$).

CHARACTERISTICS OF A- AND E-RESPONSE MODES IN DIFFERENT PARADIGMS. Now that the two major clusters have been defined in the pooled data, the question arises how this classification works out in the widely used 180° paradigm where the existence of two distinct clusters has never been reported. Our

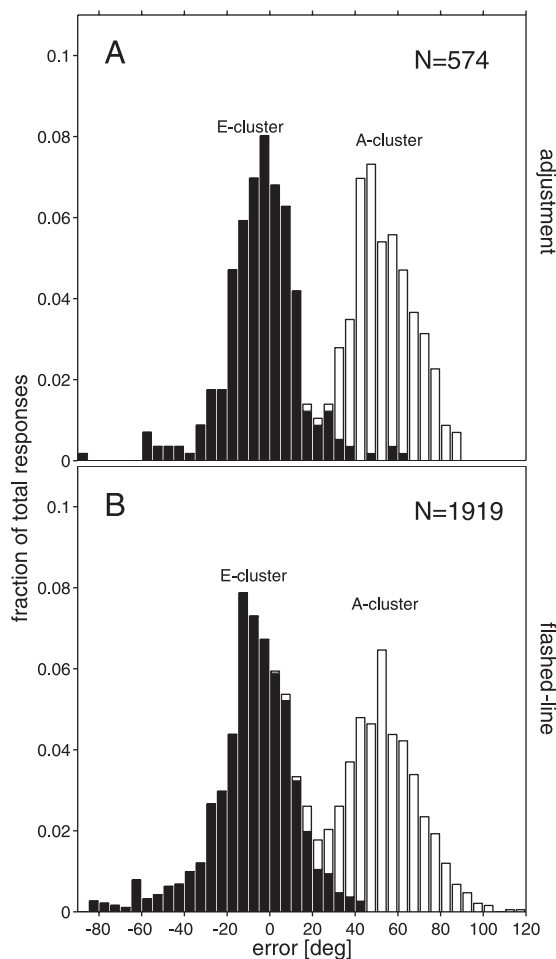

FIG. 4. Bimodal error distributions compiled from data in range 120 – 180° absolute tilt. *A*: adjustment data, *B*: flashed-line data. In both panels, subjects, paradigms and left- and rightward rotations were pooled. \blacksquare and \square , E- and A-cluster trials, respectively. Both distributions are bimodal with peaks at approximately -5° (E cluster) and 50° (A cluster). Note that the adjustment experiment and the flashed-line experiment yielded very similar results. The number of responses used in the analysis is indicated in each panel.

180° data (Fig. 3B) also show two clusters with a vertical separation. We also performed the cluster analysis on the separate paradigm data for comparison with the pooled-paradigms result. With just a few exceptions, all trials were classified into the same cluster as in the pooled cluster analysis. Closer inspection of Fig. 3B reveals that the A-E transition is shifted to a larger tilt angle. As a result, the A cluster dominates almost the entire tilt range, and the E cluster is limited to a restricted tilt range near the inverted position. A potential factor is that final tilt angle is not the only important variable and that it matters whether a short- or a long-path rotation brought the subject into the final testing position. Both trial types occurred in the standard 360° paradigm, but the 180° paradigm only had short-path rotation trials. A thorough comparison between the 180 and the 360° short-path data will be made in *Analysis of the transition zone*.

As has been mentioned earlier, responses classified in the E cluster actually show a mixture of E effects and small A effects. The fact that the E cluster in the pooled data (Fig. 3D) slopes upward from left to right indicates that this is not just a matter of random scatter around zero. Indeed, a linear regression reveals a highly significant tilt dependence, caused by a tendency toward larger E effects at tilts farther away from the inverted position ($\rho = 180^\circ$). The question is whether the E-cluster responses in the various paradigms (Fig. 3, A–C) adhere to this same tilt dependence, even if their range of occurrence may be more restricted. In other words, is there an invariant tilt-dependent relation characterizing the size of the error in a given response mode even though the probability that this response mode prevails may vary? To test this, we used a Wilcoxon rank-sum test. Grouping the subject-pooled adjustment data in adjacent 10° wide bins, for both clusters separately, we obtained three groups of data in each bin, one for each paradigm. The Wilcoxon rank-sum test on each separate bin showed no paradigm-related differences for the A cluster nor for the E cluster. We conclude that the error-tilt relation in each response mode, when activated, is paradigm invariant. As will be shown later (see subsection *Scatter and hysteresis in transition tilt angle*), the probability that a given response mode will come to expression depends not only on tilt angle but also on the direction of the preceding rotation.

CLUSTERING RESULTS FLASHED-LINE DATA. Because collecting a large data set with the adjustment method is tedious (each response requires a separate rotation trial), we also used the flashed-line paradigm (see METHODS), which yielded 12 responses in each trial. The experiments, undertaken in four of the five subjects that participated in the adjustment experiments, resulted in a roughly four times larger data set ($n = 3,702$). Because the method for collecting these data was different in various respects, it is important to check whether the results show similar characteristics. We again performed the cluster analysis on the subject-pooled data. Short- and long-path rotations and left- and rightward tilts were also pooled. Figure 5, *A* and *B*, compares the adjustment results and the flashed-line results from *subject JG*. The results are very similar.

The dip test (see METHODS) on the pooled flashed-line data collected at absolute tilts $\rho > 120^\circ$ was positive ($P < 0.001$), just as in the adjustment results. A histogram of the pooled flashed-line results for absolute tilts $>120^\circ$ can be seen in Fig.

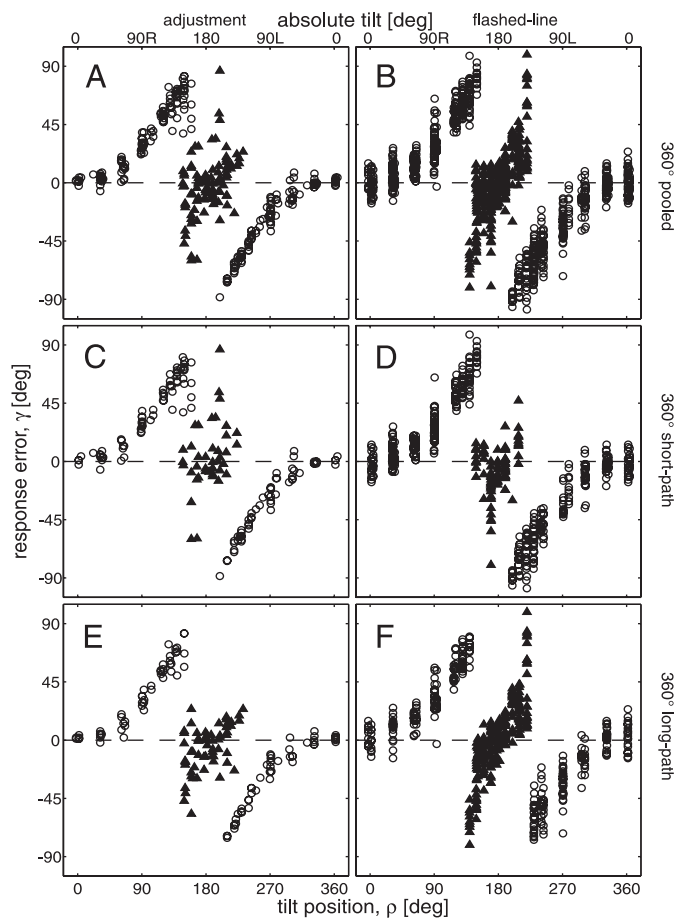

FIG. 5. The 360° adjustment and flashed-line results from 1 subject (*JG*). *A* and *B*: short- and long-path pooled. *C* and *D*: short-path results. *E* and *F*: long-path results. ○, A-cluster data; ▲, E-cluster data. Results of the adjustment data (1st column) and flashed-line data (2nd column) are very similar. *Two bottom rows*: examples of overlapping A and E clusters, illustrating that bistability is not an artifact of pooling.

4*B*. The distribution is clearly bimodal and is very similar to the histogram of the adjustment results (Fig. 4*A*). The two clusters were also present in the flashed-line data from individual subjects (see Fig. 5*B* for an example). The dip test on individual subjects on the paradigm-pooled data in the absolute tilt range $>120^\circ$ rejected unimodality ($P < 0.001$).

Analysis of the transition zone

The cluster analysis has shown that there are two distinct response clusters at large tilts in all paradigms (see Figs. 3 and 5). This bimodal character demonstrates that the A-E transition cannot be described by a continuous function. Visual inspection of the population data (Fig. 3) further suggests that the two response modes occupy slightly overlapping tilt ranges. This led us to investigate the possibility that the system can be locally bistable.

BISTABLE NATURE OF THE TRANSITION. The analysis of population data revealed signs of bistability in all adjustment paradigms. However, this result must be interpreted with caution if the A-E transition occurs at different tilt angles in different subjects. The *two bottom rows* in Fig. 5, where short- and long-path rotations are shown separately, show examples of

bistability in the 360° responses from one subject. This illustrates that the bistability phenomenon is not merely an artifact of pooling.

A survey of the adjustment and flashed-line data from individual subjects led to the following conclusions. First, bistable responses are limited to large absolute tilts, something that could already be seen in Figs. 3 and 5. Second, bistability occurs in all subjects and in all paradigms. In total, we found 48 tilt angles where both an A- and an E-type response were present within a 4° wide bin. This analysis was done for subjects, paradigms and tilt directions separately.

Further analysis of the flashed-line data concentrated on the question whether the bistability also manifests itself within a single trial. To introduce the topic, Fig. 6 shows stimulus-response relations from *subject JG*, for two different tilt angles that were each tested twice on different days. The horizontal axis, in earth-centric coordinates, plots the different orientations of the polarized line that were presented in each trial. The

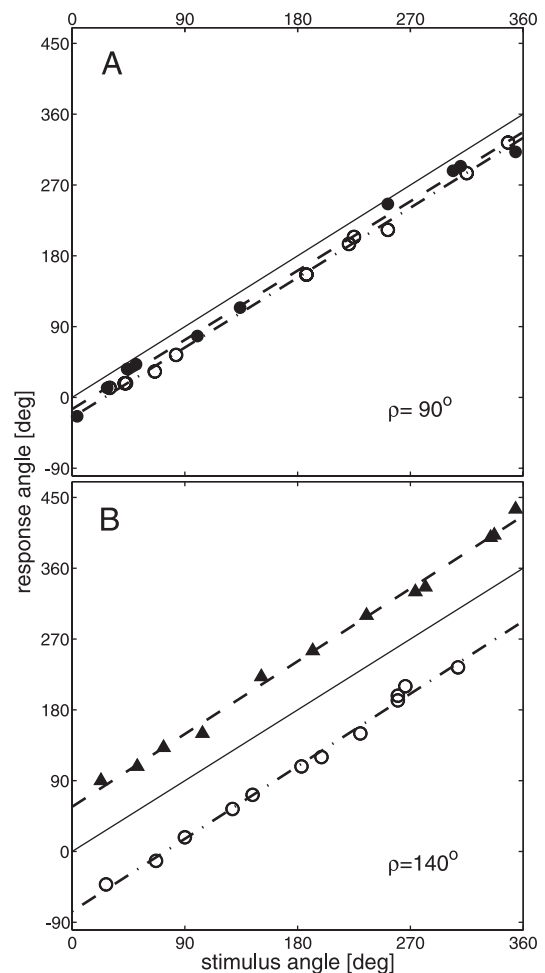

FIG. 6. Flashed-line orientation estimates in *subject JG* at 2 tilt positions. For each tilt position, the results of 2 trials are shown, indicated by different symbols. Lines --- and - · - show the results of linear regressions on the data of each trial. The best-fit parameters are: *A*: slope: 0.98 ± 0.04 , offset: -15 ± 5 , $R = 0.997$ (---); slope: 0.99 ± 0.02 , offset: -25 ± 3 , $R = 0.999$ (- · -); *B*: slope: 1.03 ± 0.03 , offset: 57 ± 6 , $R = 0.998$ (---); slope: 1.02 ± 0.03 , offset: -76 ± 6 , $R = 0.997$ (- · -). The slopes are always close to 1.0, which means that systematic errors (vertical offset) do not depend on stimulus orientation. In *A* there is an A effect in both trials. In *B*, 1 trial (○) corresponds to an A effect, the other trial (▲) to an E effect. Within each of the 4 trials all responses are of the same type, either an A or an E effect.

vertical axis represents the corresponding clock-scale estimate given by the subject, transformed into the same coordinate system. The — denotes perfect responses. The vertical shift in the responses is the expression of systematic errors in the subjective judgments. The point to be noticed is that these shifts are different among trials but consistent within a single trial, except for small noisy variations. Because the slopes of the linear-regression lines do not deviate significantly from unity (see caption), all line orientations presented in a single trial were misperceived by nearly the same angle. Thus it appears that tilting has rotated the subject's internal clock scale out of alignment with the physical vertical without distorting the scale (see Van Beuzekom et al. 2001). Because there is no sign of fluctuating systematic errors within a single trial, the examples in Fig. 6 show no sign of bistability on a short time scale. In Fig. 6A, representing data at 90° tilt, we see also no sign of bistability on repeated testing. At this tilt angle, long- and short-term variability is comparable, and all tests show a consistent A effect. However, the two trials in Fig. 6B at a larger tilt angle (140°) show a dramatic expression of bistability on repeated testing in identical trials in different sessions. The ▲ in Fig. 6B correspond to an E effect. The open circles represent an A effect. As can be seen from the offsets of the linear-regression lines, both effects are huge (A effect: -76 ± 6 ; E effect: 57 ± 6).

The question arises whether the result in Fig. 6B, with its striking expression of bistability across trials but not within trials, is typical for large tilts. To investigate this, we first identified all tilt angles where repeated testing had yielded responses in both clusters. Remarkably, this analysis showed that at the bistable tilt angles the response was rarely bistable within a single trial. We found that there were 45 flashed-line trials at bistable tilt positions. These 45 trials yielded a total of 506 recorded single-flash responses. Of these, 17 trials yielded exclusively A-cluster response strings, 16 produced pure E-cluster response strings, and 12 trials contributed both A and E responses. Of these 12 mixed trials, 9 were almost purely A or E type with one exception. In total, the selected trials yielded 270 A responses and 236 E responses.

According to the simplest model, the statistics underlying the response string to 12 lines within one trial would reflect a series of independent decisions, each involving the probabilities implied by the overall totals. If this was the case, the probability that a trial would produce a pure A-response string (0.53^{12}) or a pure E-response string (0.47^{12}) would be vanishingly small ($<0.1\%$). Because, in fact, most trials produce pure A- or E-response strings, we may conclude that the subjective visual vertical is quite stable on a time scale of many seconds.

SCATTER AND HYSTERESIS IN TRANSITION TILT ANGLE. As we have seen, the bistability findings have yielded mixed results. The disparity between within- and across-trial results would be expected if the critical tilt angle where the transition occurs in repeated trials is subject to noisy variation. To analyze the transition zone data from this perspective, we proceeded in two steps. We began by computing the frequency of E trials as a fraction of the total in adjacent 10° wide bins across the entire 0–180° range of absolute tilts by pooling left and right tilt

data. Data from short- and long-path rotations (360° experiment) and from the 180° experiment were analyzed separately. The resulting data were then fitted with an integrated Gaussian function (Eq. 1, see METHODS). Because the data sets from single subjects were not quite large enough to perform this analysis thoroughly, we performed it on the pooled data. The resulting fits for the pooled adjustment data are shown in Fig. 7A. In all three curves, the fraction of E trials rises smoothly from zero at small tilt to a value near 1.0 at 180° absolute tilt. This fact implies that the two response modes occur jointly in a certain tilt range. There are differences between the long- and short-path curves, demonstrating a hysteresis effect. The short-path curve is shifted to the right, meaning that the transition zone is displaced to a higher tilt range in the short-path data. The curve for the 180° data is still further shifted to the right, indicating that it is relevant whether short-path trials are presented in isolation or in a randomly mixed ensemble containing also long-path trials.

To interpret the curves in Fig. 7A, it is helpful to consider the underlying Gaussian curves (see Fig. 7B). These Gaussian

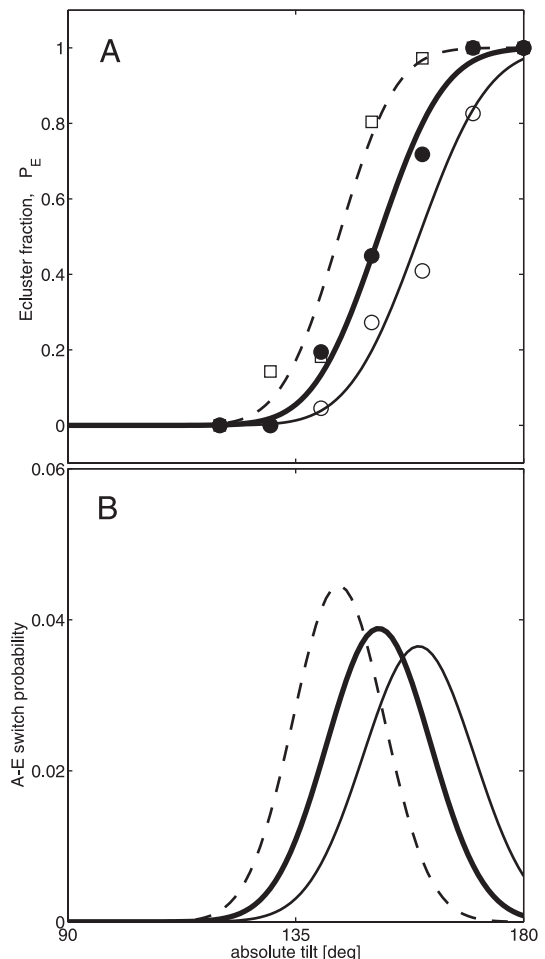

FIG. 7. Quantitative analysis of A-E transition in pooled adjustment data. *Top:* the E-cluster fraction for 360° long-path (open squares), 360° short-path (filled circles), and 180° data (open circles), together with the fits of the cumulative distribution functions (long-path: dashed line, short-path: thick solid line, 180°: thin solid line). *Bottom:* the corresponding probability distribution functions. Best-fit parameters are listed in Table 1. The curves in the *bottom* can be interpreted as the probability of switching from A to E mode as a function of absolute tilt. The fact that the 360° short-path and 360° long-path curves are displaced horizontally means that the system shows hysteresis.

distributions represent the probability of switching from the A to the E mode (or from E to A) as a function of tilt angle. Because the width of the Gaussian curves specifies the zone where most A to E transitions occur (95% occur within $\pm 2\sigma$), parameter σ is a measure of the scatter in the transition tilt angle the mean value of which is located at ρ_t . These mean and scatter values (see *Eq. 1*) are shown in Table 1, which also lists the best-fit parameters extracted from the flashed-line data. Note that the pooled flashed-line data demonstrate the same pattern as the adjustment data with very similar parameter values (see Table 1).

A caveat in the preceding analysis is that we used population data so that the curves will partly reflect idiosyncratic differences. The data that we have from four subjects consistently show a difference in ρ_t for the 360° short-path and the 360° long-path data (cf. Fig. 5, *C–F*), qualitatively compatible with the pooled data in Table 1. We had insufficient data to obtain reliable scatter estimates in individual subjects, so that the obtained σ values may represent an overestimation.

In summary, this analysis interprets the bistable zone as a probabilistic transition between two distinct response modes. It suggests that the transition tilt angle is subject to noisy scatter, a process depicted by the Gaussian curves in Fig. 7*B*. Describing the transition statistics as a Gaussian process allowed a fair characterization of the results from two different methods for testing the subjective visual vertical and from three different rotation paradigms. The results obtained by the adjustment and the scaling method were almost identical, but there were clear rotation-paradigm related differences. This paradigm dependence took the form of a hysteresis effect that caused the mean transition tilt angle to shift into the direction of the preceding rotation. Use of the 180° paradigm amplified this difference. In the DISCUSSION, we explore two hypotheses on how the hysteresis effect and the scatter in the transition tilt angle may come about.

DISCUSSION

Overview of main findings

When tilted sideways in the dark, subjects estimating the direction of gravity make systematic errors (A effects) for tilts up to $\sim 135^\circ$ and show an abrupt transition to errors of opposite sign (E effect) for larger tilts (Kaptein and Van Gisbergen

TABLE 1. Best-fit parameters for cumulative transition curves in different paradigms

Rotation	Mean (ρ_t)		Scatter (σ)	
	Adjust	Flash	Adjust	Flash
360° long path	143 \pm 1	142 \pm 1	9 \pm 2	8 \pm 1
360° short path	151 \pm 2	154 \pm 1	10 \pm 2	12 \pm 1
180° short path	159 \pm 2	—	11 \pm 2	—

Results are from the subject-pooled data. The results obtained with the adjustment (see Fig. 7) and the flashed-line method are shown separately. Recall that the 180° paradigm was not done with the flashed-line method. Results for adjustment and flashed-line data are quite similar. Mean transition tilt angle is lowest for the 360° long-path condition and highest for the 180° condition. Scatter is smallest for the 360° long-path condition. The 180° condition and the 360° short-path condition have similar scatter. All measures in degrees as means \pm SD.

2004). The present study was undertaken to study the nature of this A-E transition and to find out whether it can best be characterized by a continuous function, a discontinuous function, or as a bifurcation of a bistable system. Because this transition was not noticed in earlier studies, we also investigated how its expression depended on the experimental paradigm used for subject rotation and for testing the subjective visual vertical.

EVIDENCE FOR TWO DISTINCT RESPONSE MODES. Our results demonstrate that the tilt-dependent pattern of systematic errors in the subjective visual vertical cannot be described by a continuous function. Cluster analysis singled out two distinct response modes at large absolute tilts ($\geq 135^\circ$) that even stood out clearly in the pooled population data (Fig. 3*D*). Further statistical analysis confirmed that the error distributions of the two response clusters, termed A and E cluster, were separated by a gap (Fig. 4). This demonstration of two distinct response modes allowed us to classify each trial as either A or E type. The response error distributions in both the A and the E cluster are tilt dependent. In the A cluster, there is a pronounced monotonic increase in the size of the error with tilt angle, similar to the trend known from previous studies (Udo de Haes 1970; Van Beuzekom and Van Gisbergen 2000). In the E cluster, mean errors are small and tend to decrease to zero as tilt approaches the inverse position. A linear regression on the pooled E-cluster data (Fig. 3*D*) returns a slope of 0.29 ± 0.05 , which is in close agreement with the slope found in Kaptein and Van Gisbergen (2004).

EXPRESSION OF THE TWO RESPONSE MODES IN VARIOUS PARADIGMS. The two response modes were plainly visible in the results of the various adjustment paradigms (Fig. 3) and in the flashed-line data (Fig. 5). We found that use of a polarized or a nonpolarized line made no obvious difference (see Fig. 3, *A* and *C*). The adjustment experiments used both short- and long-path rotations (see Fig. 2*A*). These were either mixed randomly (360° paradigm) or presented as a separate series (180° paradigm). In the 360° data, the two response modes were manifest in individual subjects (Fig. 5, 2 bottom rows) as well as in the population data (Fig. 3, *A* and *C*). In the 180° experiment, the pooled data again showed the two clusters (Fig. 3*B*), but this was not always unmistakable in individual subjects. The results from the 360° paradigm showed that the tilt ranges occupied by the A- and E-response modes depended on rotation paradigm (see Fig. 7). We found an earlier onset of the E-response mode in long-path rotations. In the 180° experiments, the range dominated by the E-response mode was even more displaced to higher tilts than in the 360° short-path rotations (see Fig. 7). This difference is remarkable because the physical stimulus was exactly the same in the two conditions. The only difference was the set in which the trials were embedded. The 180° experiment contained only short-path trials, whereas the 360° short-path data were collected in experiments containing both trial types. Because subjects were always told what the maximum rotation would be, a plausible reason for the difference is prior knowledge. That prior knowledge about the experimental paradigm and other cognitive effects may affect the responses in vestibular psychophysics has been noticed before (Mast et al. 2001; Wertheim et al. 2001; Wright and Glasauer 2003).

The result that the emergence of two distinct response modes was robust in each separate paradigm and was even retained after pooling across all adjustment experiments and all subjects leaves unexplained why this feature was not noticed in earlier studies (Udo de Haes 1970; Van Beuzekom and Van Gisbergen 2000). There have been a few incidental reports of two response modes in vestibular experiments. Udo de Haes and Schöne (1970) and Fischer (1930) reported different line settings at large tilts, similar to what we found. Pettorossi et al. (1999) reported a sudden change in direction of reflexive eye movements in rabbits when tilt exceeded a critical threshold. The fact that the two modes in the subjective visual vertical were not noticed before, except in a few anecdotal reports, may have several reasons. First of all, we would have overlooked the two distinct response modes in our 180° data, if we had applied the common practice of computing the average response at each tilt angle. To illustrate this, we refer to Fig. 8 where this procedure was applied to our own data. As can be seen, the result is a smooth curve that is very similar to classical data in the literature (Mittelstaedt 1983; Schöne 1964). A further artifact resulting from simply averaging bimodally distributed data is the suggestion of a hysteresis effect at $\rho = 180^\circ$, of the type described in Van Beuzekom and Van Gisbergen (2000). The actual distribution of the data points does not support such an effect.

Other factors that may explain why the two response modes were not noticed before include the need for fine sampling at closely spaced tilt angles and for repeated testing, to ensure a sufficiently large database. The latter point may help to explain why the bimodal character is not always visible in data from individual subjects, even when its expression in pooled data is convincing.

BISTABILITY AND HYSTERESIS FINDINGS. The analysis of the responses in the transition zone (RESULTS) has yielded the

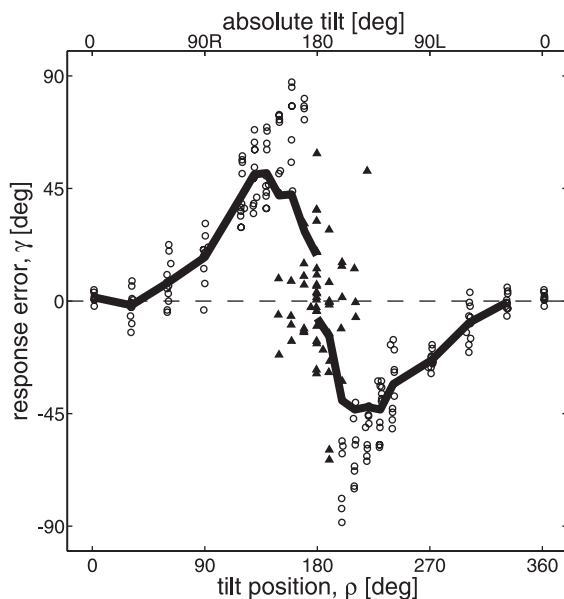

FIG. 8. Mean response error in pooled 180° paradigm data. ○ and ▲, A and E cluster, respectively (see Fig. 3B). Solid line shows that computing the overall mean, ignoring the existence of 2 separate clusters, is misleading. The mean curve shows a smoothly increasing and decaying A effect and hysteresis at 180° tilt. The curve is very similar to the one found by Van Beuzekom and Van Gisbergen (2000).

following picture: 1) pooled data from multiple sessions show that the two response modes occur jointly in part of the tilt range. In this overlap zone, the subject may produce an A-type response in one trial and an E-type response in another trial (see Fig. 6B). This result was seen in the adjustment experiments and in data from repeated flashed-line experiments. Further analysis (Fig. 7) showed a hysteresis effect in that the bistable zone was shifted, depending on whether the data were collected in short-path or in long-path rotation trials. This paradigm dependence is illustrated schematically in Fig. 10. 2) Analysis of the single-trial data obtained with the flashed-line method, which allowed repeated testing, established that flipping between response modes was very rare on a 30-s time scale. Most response strings within the single trial belonged to a single response category (either A or E).

These findings suggest that the system is not intrinsically bistable but that the critical tilt angle at which the transition occurs varies between trials. This noisy variation is represented by the Gaussian curves in Fig. 7B. In “*Interpretation of the bistability and hysteresis findings*” these findings will be discussed in more detail.

Transition may represent a shift in reference frame

EVIDENCE THAT THE TRANSITION HAS A CENTRAL ORIGIN. Reconstructing the orientation of a visual contour in terrestrial coordinates requires information about line orientation on the retina and about body tilt. According to the literature, body-tilt information may involve various sources such as the otoliths (Mittelstaedt 1983), the semicircular canals (Keusch et al. 2004; Pavlou et al. 2003) and the somatosensory system (Anastasopoulos and Bronstein 1999; Bronstein et al. 1996). A peripheral explanation of the A-E transition, in the sense that this phenomenon reflects a tilt-related discontinuity in the properties of primary sensory afferents, seems unlikely. First, the tilt range where the sudden jump occurred was different in the 180° and the 360° short-path data although the physical conditions in the preceding rotation and during testing in the stationary condition were exactly the same. Second, the analysis of subjective body tilt estimates in Kaptein and Van Gisbergen (2004), collected under similar conditions, showed that the jump in the subjective visual vertical has no parallel in perceived body tilt.

EVIDENCE THAT THE TRANSITION REFLECTS A SHIFT IN COMPUTATIONAL STRATEGY. A striking feature of visual verticality estimates during external space perception in the dark, found beyond 60° tilt, is a severe undercompensation for lateral body tilt (A effect). Because body-posture percepts do not have these systematic errors (see Kaptein and Van Gisbergen 2004; Van Beuzekom and Van Gisbergen 2000), the question must be faced why external space perception would accept these seemingly unnecessary errors. Two different explanations, invoking different mechanisms but in essence mathematically equivalent, have been proposed (Eggert 1998; Mittelstaedt 1983). Both models interpret the A effect as the downside of a computational strategy for optimizing performance at small tilt.

If the A effect reflects a computational strategy, could the brusque departure from this response mode in the A-E transition represent a shift in strategy? This interpretation requires

that there should be some advantage for the system to justify this added complexity. The strong improvement in performance (smaller systematic errors) engendered by the transition indeed seems to argue in favor of a strategy shift. What still remains to be explained, though, is why the transition gives rise to errors of opposite sign (E effect). Whereas the A effect represents a bias toward the head, the E responses at near inverse tilt can be interpreted as a bias toward the opposite body pole (the feet), suggesting a possible shift in reference.

Indirect evidence that the strategy shift may indeed involve a reference shift was obtained in a supplementary experiment. This work was inspired by comments from several experienced subjects who had participated in multiple sessions. These comments suggested that task execution at large tilt trials confronted them with problems that were not apparent at smaller tilts. A recurring theme in these subjective appraisals is the contrast between a more indirect approach in task execution at large tilt and more automatic settings at smaller tilts. A more detailed account of these comments sketches the following scenario. For most of the tilt range, subjects have a vivid percept of up and down and the orientation of the horizon. Because the subjective cardinal axes of external space are directly available as a reference, setting the line to the vertical is effortless without necessitating conscious awareness of how one it tilted. This type of task execution, without conscious use of perceived body tilt, will be denoted as the default response strategy. At very large tilts near the inverted position, spatial awareness (where is the horizon?) may be lacking. Under such conditions, the direction of "up" is reconstructed indirectly from the only vivid percept that is momentarily available: the strong sense of being tilted at a very large angle. Based on this awareness, the brain decides that the line should be aligned near the direction of the upward pointing feet. Small sensed deviations from inverted tilt then guide small adjustments relative to this reference. We will denote this as the alternative strategy.

We considered that this suggested dichotomy would gain significance and credibility if it could be linked to the A- and E-response modes. In four subjects (2 naive) who had participated in many previous subjective vertical experiments, we repeated the 360° paradigm using the adjustment method. After the line setting was made, we asked them to indicate whether their response had been effortless and automatic or whether they had been aware of using their percept of body tilt as an intermediary step to obtain the line setting (forced choice). Care was taken that all subjects understood these instructions. After the verbal responses had been collected, we relabeled them to the shorthand terms default and alternative for descriptive purposes.

The result of this experiment can be seen in Fig. 9. Remarkably, default (○) and alternative (▲) judgments corresponded almost perfectly to the two major clusters distinguished before (Fig. 3). Note that this is not just a loose coupling which arises because both the proportion of E trials and the proportion of alternative responses increase with tilt angle. The fact that there is an almost one-to-one correlation in the tilt region where A and E responses are mixed rules out that the relation is spurious.

Partly on the basis of these results, we hypothesize that the seemingly odd error reversal in the A-E transition may reflect the use of different internal references by the default system

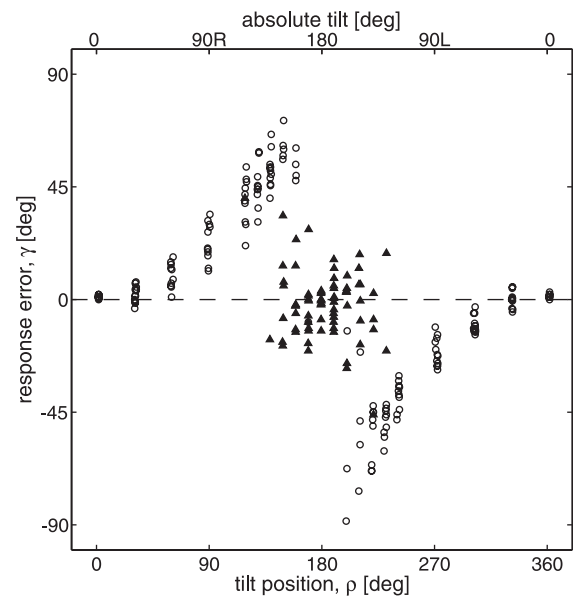

FIG. 9. Default vs. alternative trial ratings, in the pooled data from 4 subjects. ○, trials rated "default." ▲, trials classified as "alternative." With only 7 exceptions, default and alternative trials match perfectly with the A and E cluster, respectively. Total number of trials: 236.

and the alternative system when adjusting line settings for sensed body tilt. According to this scenario, when the system is in the default mode (responsible for A responses), it compensates line settings for the tilt deviation of the head from upright (Fig. 10, *top inset*). At large tilts, the alternative system (responsible for E responses) bases its line settings on the tilt deviation of the feet from upright (Fig. 10, *bottom inset*), which equals the deviation of the head from the upside-down position. In both modes, the sensed tilt deviation from the chosen reference is under-compensated, with opposite errors in line settings as a result. In this way, the hypothesis also provides a simple explanation for the discontinuous nature of the A-E transition. Without the putative reference shift, the error reversal (A to E) would be hard to explain.

A further major question is why is the mean transition tilt angle (ρ_t) is different for long-path and short-path rotations and how this relates to the bistability. These topics are the subject of the next section.

Interpretation of the bistability and hysteresis findings

The literature on the subjective visual vertical contains anecdotal reports of bistable responses, but this phenomenon has never been subject of systematic study. For example, Fischer (1930), Schöne (1964), and Udo de Haes and Schöne (1970) noticed that subjects sometimes doubted between two possible settings. Our flashed line data showed that the sense of verticality is quite stable on a 30-s time scale. However, a bistable response pattern did emerge at large tilt angles if subjects were repeatedly tested in multiple sessions (see Figs. 5 and 6). The two seemingly conflicting sets of data can be reconciled. Apparently, the decision as to which response mode prevails is taken early in the trial and is generally irreversible. As a result, all responses in a given trial are typically of the same type (Fig. 6B). That the system may nonetheless appear bistable on repeated testing on different

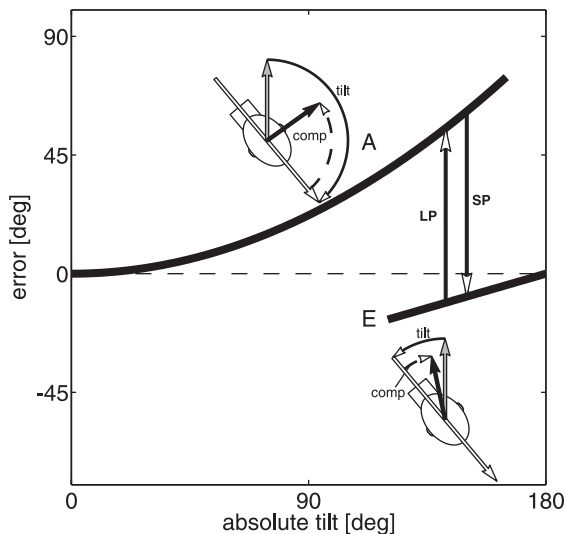

FIG. 10. Schematic illustration of hysteresis in 360° data. Scheme shows mean A and E responses and indicates how the mean transition angle (see Table 1) is different for short-path (A to E) and long-path (E to A) rotations. The mean curve for the A cluster was obtained by fitting a quadratic function (see METHODS) to the pooled A-cluster data (Fig. 3D). The E-cluster line is the result of the linear regression on the pooled E-cluster data (Fig. 3D). The best-fit parameter for the A cluster: $a = 0.00270 \pm 0.00003$; $R = 0.86$; $n = 752$. Insets show how a reference shift can explain the error reversal. When the system works in A mode, the line setting relative to the body axis compensates (comp) only partially for the tilt deviation of the head. When in E mode, line settings compensate only partially for the tilt deviation of the feet from upright. Partial compensation for the tilt deviation of the head from upside down would have the same effect. Gray arrow denotes the upward direction. Subjective visual vertical is indicated by a black arrow, the body axis by a white arrow (subject seen from behind).

days can be ascribed to noisy variations in the tilt angle where the A-E transition may occur (see Fig. 7B). This linkage to the A-E transition also explains why the bistability phenomenon is limited to a restricted range of angles, always at high tilt.

Udo de Haes and Schöne (1970) and Fischer (1930) also described a hysteresis phenomenon in the subjective visual vertical. These authors noticed that subjective vertical settings at a given static tilt angle were different depending on the direction of the preceding rotation. Udo de Haes and Schöne (1970) attributed this finding to an aftereffect of the semicircular canals. Although there is indeed indirect evidence for a role of the canals in the subjective visual vertical (Jaggi-Schwarz and Hess 2003; Jaggi-Schwarz et al. 2003; Keusch et al. 2004; Pavlou et al. 2003), a problem with the Udo de Haes and Schöne (1970) hypothesis has always been that it cannot easily explain why the hysteresis is restricted to large tilt angles. Our analysis suggests a different origin for the hysteresis which also explains why this phenomenon occurs only at large tilts. We find that there are two potential response modes at large tilt with very different responses and that the system's preference for one mode or the other, at a given tilt angle, depends on how that tilt angle was approached (see Fig. 10). We have no evidence that the response modes, as such, are affected by the direction of the preceding rotation. In RESULTS, Wilcoxon rank-sum tests showed that the tilt dependences of both the A and E cluster were not significantly different among paradigms.

SWITCHING MECHANISM. We now concentrate on the question of how the shifts between the two computational strategies, as

a function of tilt angle and as a function of the experimental paradigm, can be understood. As a simple model for the switching mechanism we suggest that the brain applies a criterion to some tilt-related signal to determine which response mode should be adopted. The challenge is to come up with a plausible candidate for this signal that can account for the statistical characteristics of the shifting behavior.

In our previous study (Kaptein and Van Gisbergen 2004), we suggested that the tilt-related signal driving the decision might be the line setting relative to the body (β) proposed by the default mechanism (A mode). For the definition of β , see Fig. 2. According to this idea, the brain would switch to the E mode when β exceeds a certain criterion. Specifically we proposed a criterion of β near 90°, corresponding to a line setting perpendicular to the body axis. To illustrate the rationale behind this idea, Fig. 11 shows β values from the pooled adjustment data set as a function of absolute tilt. The subjective-vertical task requires that subjects set the line using $\beta = \rho$ (dashed line with slope 1). As tilt increases, β remains more and more behind the required value, which means that the system becomes less and less sensitive to further tilt increments, with huge A effects as a result. Therefore it seemed reasonable to suggest that the shift in response mode, which leads to a dramatic reduction in systematic errors, might be provoked by the saturation in the β values proposed by the default A system. It appears that to account for the experimentally obtained ρ_t values, β criteria near 90° would indeed be adequate. Small differences of a few degrees would be sufficient to account for paradigm-related differences.

The major problem with proposing β as the tilt-related signal that drives the switching mechanism is that the noise characteristics of the β signal cannot account for the width of the bistable zone. Why the noise characteristics create a problem is illustrated in Fig. 11. The intersection of the $\beta = 90^\circ$ line with the β data is much broader than the width of the transition

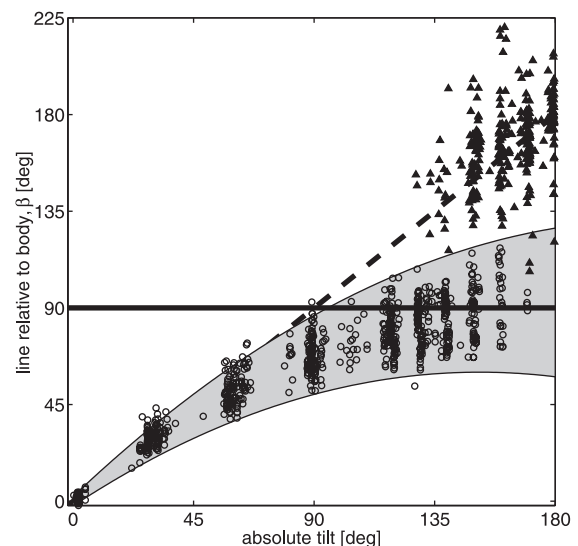

FIG. 11. Line settings relative to body (β) as a function of absolute tilt. Paradigms and subjects were pooled. The 2 clusters are indicated by \circ (A) and \blacktriangle (E). - - -, perfect compensation. The A cluster clearly illustrates that tilt is undercompensated. Horizontal — shows that the $\beta = 90^\circ$ line has a very broad intersection with the data, making it an unlikely criterion. Also indicated (gray zone) is a 4σ wide band centered at mean β . The mean β curve (not shown) and the 4σ curves are based on the fits from Figs. 10 and 12.

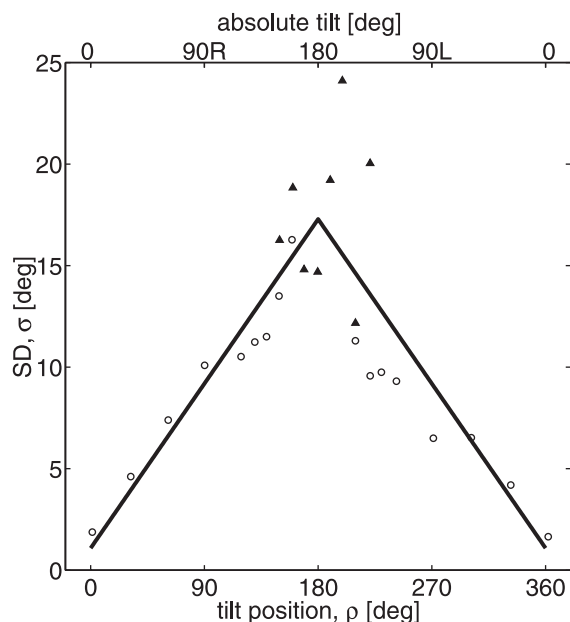

FIG. 12. Scatter in the adjustment data. All 5 subjects and all 3 paradigms were pooled. The scatter in the A cluster (\circ) and E cluster (\blacktriangle) was analyzed separately. Note strong increase in random error with tilt angle. Also note that there is no clear difference between scatter in the A cluster at large tilts and the scatter in the E cluster. —, result of linear regression. The fit was performed on scatter as a function of absolute tilt, so left- and rightward tilt positions were pooled. Best-fit parameters are slope: 0.09 ± 0.01 , offset: 1.1 ± 0.9 , $R = 0.85$, $P < 0.0001$.

curves (Fig. 7). The $\beta = 90^\circ$ criterion, necessary to match the location of the bistable zone along the tilt axis, implies that the first A-E transitions should already occur near 90° absolute tilt. The actual width of the bistable zone is much narrower so that the β -criterion hypothesis has to be rejected.

The gray zone in Figure 11 indicates the noise level in β as a 4σ band around the mean. Figure 12 shows how this tilt dependence of the noise level in the pooled adjustment data was derived using a simple linear fit. The noise increases with tilt from ~ 2 to 15 – 20° . The scatter in the E cluster is more or less a continuation of the scatter in the A cluster. Of course, calculating the scatter without making the distinction between the two clusters will result in a large noise peak in the bistable zone. Such a peak has been found by Udo de Haes (1970), suggesting that bistability may have confounded his scatter estimates.

We now consider the hypothesis that the signal driving the switching decision is the subject's perceived body tilt signal. This signal is a promising candidate because it shows hysteresis in the right direction and by roughly the amount required to explain the bistability data with a single threshold criterion. Kaptein and Van Gisbergen (2004) showed that perceived body tilt for short-path rotations is on average veridical, whereas for long-path rotations, subjects tend to overestimate their body tilt by $\sim 11^\circ$ at the critical tilt range where the transition occurs.

Accordingly, a shift criterion set at 150° absolute tilt would cause an A-E transition at an absolute tilt of $\sim 150^\circ$ for short-path rotations but at a smaller tilt of about 139° for long-path rotations. This is close to the actual ρ_t values computed from the 360° data (Table 1). Furthermore, Van Beuzekom and Van Gisbergen (2000), using the 180° para-

digms, noted a small underestimation in perceived body tilt, which was not apparent in the 360° short-path tilt estimates (Kaptein and Van Gisbergen 2004). The underestimation that they found near 160° absolute tilt, $\sim 10^\circ$, would explain the difference between our 180° and 360° short-path data (Table 1).

If the perceived body-tilt criterion determining the shift is fixed, the present hypothesis implies that the width of the bistable zone reflects the noise in the perceived body-tilt signal. Data for the 180° paradigm (Van Beuzekom and Van Gisbergen 2000) show an average SD of $\sim 8^\circ$ for the large tilt range $>90^\circ$, which is roughly in agreement with our findings (σ values in Table 1). Because these σ -values concern subject-pooled data, they may be overestimated.

Overall conclusions

The clustering analysis has shown two distinct response modes (A and E) in the subjective visual vertical task at large tilt in all three tested rotation paradigms and in all subjects.

Reports on how the task was executed suggest a shift in computational approach. If the error reversal is interpreted as a reference shift, from compensating line settings for the head deviation from upright to compensating for the deviation of the feet from upright, both the A and the E effect can be seen as signs of tilt undercompensation. This hypothesis also explains the discontinuous nature of the A-E transition.

Statistical analysis showed that the tilt angle where the transition occurred was subject to noisy variation in repeated trials. This variability caused an appearance of bistability in pooled data from multiple sessions even though the subjective visual vertical was found to be quite stable on a shorter time scale.

Comparison of data from different rotation paradigms revealed a hysteresis phenomenon in that the transition zone shifted into the direction of the previous rotation. By contrast, the error-tilt relation characterizing each response mode was unaffected.

The noisy variability in the transition tilt angle and its dependence on the direction of the preceding rotation can be explained if a noisy tilt signal with hysteresis properties enforces the shifting decision by crossing a fixed threshold. A promising candidate signal, endowed with such properties, is perceived body tilt.

ACKNOWLEDGMENTS

We thank H. Kleijnen, G. Van Lingen, and G. Windau for providing technical support. T. Heskes and T. Dijkstra are acknowledged for advice on statistical matters. W. P. Medendorp and R. Vingerhoets gave valuable comments on an earlier version of this manuscript.

GRANTS

This study was supported by ALW (Foundation for Earth and Life Sciences).

REFERENCES

- Anastasopoulos D and Bronstein AM. A case of thalamic syndrome: somatosensory influences on visual orientation. *J Neurol Neurosurg Psychiatry* 67: 390–394, 1999.
- Bronstein AM, Yardley L, Moore AP, and Cleaves L. Visually and posturally mediated tilt illusion in Parkinson disease and in labyrinthine defective subjects. *Neurology* 47: 651–656, 1996.

- Eggert T.** *Der Einfluss orientierter Texturen auf die subjektive Vertikale und seine systemtheoretische Analyse* (PhD thesis). Munich, Germany: Munich Technical University, 1998.
- Fischer MH.** Messende Untersuchungen über die Gegenrollung der Augen und die Lokalisation der scheinbaren Vertikalen bei seitlicher Neigung des Gesamtkörpers bis zu 360°. *Graefes Arch Ophthalmol* 123: 476–508, 1930.
- Hartigan JA and Hartigan PM.** The dip test of unimodality. *Ann Statist* 13: 70–84, 1985.
- Hartigan PM.** Computation of the dip statistic to test for unimodality. *Appl Statist* 34: 320–325, 1985.
- Howard IP.** *Visual Orientation to Gravity*. New York: Wiley, 1982.
- Howard IP.** The perception of posture, self motion, and the visual vertical. In: *Handbook of Perception and Human Performance*, edited by Boff. KR, Kaufman L, and Thomas JP. New York: Wiley, 1986, p. 1–50.
- Jaggi-Schwarz K and Hess BJM.** Influence of dynamic tilts on the perception of earth-vertical. *Exp Brain Res* 149: 340–350, 2003.
- Jaggi-Schwarz K, Ortega M, and Hess BJM.** Reciprocal error behaviour in estimated body position and subjective visual vertical. *Exp Brain Res* 150: 122–125, 2003.
- Kaptein RG and Van Gisbergen JAM.** Interpretation of a discontinuity in the sense of verticality at large body tilt. *J Neurophysiol* 91: 2205–2214, 2004.
- Keusch S, Hess BJ, and Jaggi-Schwarz K.** Direction specific error patterns during continuous tracking of the subjective visual vertical. *Exp Brain Res* 155: 283–290, 2004.
- Mast FW, Berthoz A, and Kosslyn SM.** Mental imagery of visual motion modifies the perception of roll-vection stimulation. *Perception* 30: 945–957, 2001.
- Mittelstaedt H.** A new solution to the problem of the subjective vertical. *Naturwissenschaften* 70: 272–281, 1983.
- Pavlou M, Wijnberg N, Faldon ME, and Bronstein AM.** Effect of semicircular canal stimulation on the perception of the visual vertical. *J Neurophysiol* 90: 622–630, 2003.
- Pettorossi VE, Errico P, Ferraresi A, and Barmack NH.** Optokinetic and vestibular stimulation determines the spatial orientation or negative optokinetic afternystagmus in the rabbit. *J Neurosci* 19: 1524–1531, 1999.
- Press WH, Flannery BP, Teukolsky SA, and Vetterling WT.** *Numerical Recipes in C* (2nd ed.). Cambridge, UK: Cambridge, 1992.
- R Development Core Team.** *R: A Language and Environment for Statistical Computing*. Vienna, Austria: R Foundation for Statistical Computing, 2004.
- Schöne H.** On the role of gravity in human spatial orientation. *Aerospace Medicine* 35: 764–772, 1964.
- Udo de Haes HA.** Stability of apparent vertical and ocular countertorsion as a function of lateral tilt. *Percept Psychophys* 8: 137–142, 1970.
- Udo de Haes HA and Schöne H.** Interaction between statolith organs and semicircular canals on apparent vertical and nystagmus. *Acta Otolaryngol* 69: 25–31, 1970.
- Van Beuzekom AD, Medendorp WP, and Van Gisbergen JAM.** The subjective vertical and the sense of self orientation during active body tilt. *Vision Res* 41: 3229–3242, 2001.
- Van Beuzekom AD and Van Gisbergen JAM.** Properties of the internal representation of gravity inferred from spatial-direction and body-tilt estimates. *J Neurophysiol* 84: 11–27, 2000.
- Wertheim AH, Mesland BS, and Bles W.** Cognitive suppression of tilt sensations during linear horizontal self-motion in the dark. *Perception* 30: 733–741, 2001.
- Wichmann FA and Hill NJ.** The psychometric function. I. Fitting, sampling and goodness of fit. *Percept Psychophys* 63: 1293–1313, 2001.
- Wright WG and Glasauer S.** Haptic subjective vertical shows context dependence: task and vision play a role during dynamic tilt stimulation. *Ann NY Acad Sci* 1004: 531–535, 2003.