

## The NCCN

# Non-Hodgkin's Lymphomas

## Clinical Practice Guidelines in Oncology™

Andrew D. Zelenetz, MD, PhD; Jeremy S. Abramson, MD; Ranjana H. Advani, MD; C. Babis Andreadis, MD; John C. Byrd, MD; Myron S. Czuczman, MD; Luis Fayad, MD; Andres Forero, MD; Martha J. Glenn, MD; Jon P. Gockerman, MD; Leo I. Gordon, MD; Nancy Lee Harris, MD; Richard T. Hoppe, MD; Steven M. Horwitz, MD; Mark S. Kaminski, MD; Youn H. Kim, MD; Ann S. LaCasce, MD; Tariq I. Mughal, MD; Auyporn Nademanee, MD; Pierluigi Porcu, MD; Oliver Press, MD, PhD; Leonard Prosnitz, MD; Nashitha Reddy, MD; Mitchell R. Smith, MD, PhD;

Lubomir Sokol, MD, PhD; Lode Swinnen, MB, ChB; Julie M. Vose, MD; William G. Wierda, MD, PhD; Joachim Yahalom, MD; and Furhan Yunus, MD

### Overview

Non-Hodgkin's lymphomas (NHLs) are a heterogeneous group of lymphoproliferative disorders originating in B-, T-, or natural killer (NK) lymphocytes. In the United States, B-cell lymphomas represent 80% to 85% of all cases, with 15% to 20% being T-cell lymphomas; NK lymphomas are very rare. In 2009, an estimated 65,980 new cases of NHL will be diagnosed and 19,500 will die of the disease.<sup>1</sup> NHL is the sixth leading site of new cancer cases among men and fifth among women, accounting for 4% to 5% of new cancer cases and 3% to 4% of cancer-related deaths.<sup>1</sup>

## Non-Hodgkin's Lymphomas Clinical Practice Guidelines in Oncology

### Key Words

NCCN Clinical Practice Guidelines, non-Hodgkin's lymphoma, chronic lymphocytic leukemia, follicular lymphoma, diffuse large B-cell lymphoma, mantle cell lymphoma, peripheral T-cell lymphoma, cutaneous T-cell lymphoma, mycosis fungoides, Sézary syndrome, marginal zone lymphoma, mucosa-associated lymphoid tissue lymphoma, diagnosis, treatment, hematopathology, immunohistochemistry, treatment guidelines, staging evaluation, lymphoma pathology (*JNCCN* 2010;8:288–334)

### NCCN Categories of Evidence and Consensus

**Category 1:** The recommendation is based on high-level evidence (e.g., randomized controlled trials) and there is uniform NCCN consensus.

**Category 2A:** The recommendation is based on lower-level evidence and there is uniform NCCN consensus.

**Category 2B:** The recommendation is based on lower-level evidence and there is nonuniform NCCN consensus (but no major disagreement).

**Category 3:** The recommendation is based on any level of evidence but reflects major disagreement.

All recommendations are category 2A unless otherwise noted.

The full NCCN Clinical Practice Guidelines in Oncology: Non-Hodgkin's Lymphomas are not printed in this issue of *JNCCN*, but can be accessed online at [NCCN.org](http://NCCN.org).

Clinical trials: The NCCN believes that the best management for any cancer patient is in a clinical trial. Participation in clinical trials is especially encouraged.

### Please Note

These guidelines are a statement of consensus of the authors regarding their views of currently accepted approaches to treatment. Any clinician seeking to apply or consult these guidelines is expected to use independent medical judgment in the context of individual clinical circumstances to determine any patient's care or treatment. The National Comprehensive Cancer Network makes no representation or warranties of any kind regarding their content, use, or application and disclaims any responsibility for their applications or use in any way.

These guidelines are copyrighted by the National Comprehensive Cancer Network. All rights reserved. These guidelines and the illustrations herein may not be reproduced in any form without the express written permission of the NCCN © 2010.

### Disclosures for the NCCN Non-Hodgkin's Lymphomas Guidelines Panel

At the beginning of each NCCN guidelines panel meeting, panel members disclosed any financial support they have received from industry. Through 2008, this information was published in an aggregate statement in *JNCCN* and online. Furthering NCCN's commitment to public transparency, this disclosure process has now been expanded by listing all potential conflicts of interest respective to each individual expert panel member.

Individual disclosures for the NCCN Non-Hodgkin's Lymphomas Guidelines Panel members can be found on page 334. (To view the most recent version of these guidelines and accompanying disclosures, visit the NCCN Web site at [NCCN.org](http://NCCN.org).)

These guidelines are also available on the Internet. For the latest update, please visit [NCCN.org](http://NCCN.org).

## Journal of the National Comprehensive Cancer Network

The incidence of NHL increased dramatically between 1970 and 1995; the increase has moderated since the mid-1990s. This increase has been attributed partly to the HIV epidemic and the development of AIDS-related NHL. However, much of the increased incidence has been observed in patients in their sixth and seventh decades, and has largely paralleled a major decrease in mortality from other causes. Because the median age of individuals with NHL has risen in the past 2 decades,<sup>2</sup> patients with NHL may also have significant comorbid conditions, which can complicate treatment options.

NOTE: This manuscript highlights only a portion of the NCCN Non-Hodgkin's Lymphoma Guidelines. Please refer to [www.NCCN.org](http://www.NCCN.org) for the complete guidelines.

**Classification**

In the 1956, Rappaport et al.<sup>3</sup> proposed a lymphoma classification based on the pattern of cell growth (nodular or diffuse), and size and shape of the tumor cells.<sup>4</sup> This classification, although widely used in the United States, quickly became outdated with the discovery and existence of distinct types of lymphocytes (B, T, and NK). The Kiel classification, which divided the lymphomas into low- and high-grade based on histologic features, became the first and most significant classification system to apply this new information to lymphomas.<sup>5-7</sup> This classification was widely used in Europe. However, the use of different classification systems in clinical studies made it difficult to compare results. Hence, the International Working Formulation (IWF) for NHLs was developed to stan-

Text continues on p. 313

**NCCN Non-Hodgkin's Lymphomas Panel Members**

\*Andrew D. Zelenetz, MD, PhD/Chair†P  
 Memorial Sloan-Kettering Cancer Center  
 Jeremy S. Abramson, MD†‡  
 Massachusetts General Hospital Cancer Center  
 Ranjana H. Advani, MD†  
 Stanford Comprehensive Cancer Center  
 C. Babis Andreadis, MD‡  
 UCSF Helen Diller Family Comprehensive Cancer Center  
 John C. Byrd, MD†P  
 The Ohio State University Comprehensive Cancer Center –  
 James Cancer Hospital and Solove Research Institute  
 Myron S. Czuczman, MD†‡  
 Roswell Park Cancer Institute  
 Luis Fayad, MD†‡P  
 The University of Texas M. D. Anderson Cancer Center  
 Andres Forero, MD†‡P  
 University of Alabama at Birmingham  
 Comprehensive Cancer Center  
 Martha J. Glenn, MD†‡P  
 Huntsman Cancer Institute at the University of Utah  
 Jon P. Gockerman, MD†‡  
 Duke Comprehensive Cancer Center  
 Leo I. Gordon, MD‡  
 Robert H. Lurie Comprehensive Cancer Center of  
 Northwestern University  
 Nancy Lee Harris, MD‡  
 Massachusetts General Hospital Cancer Center  
 Richard T. Hoppe, MD‡  
 Stanford Comprehensive Cancer Center  
 Steven M. Horwitz, MD†P  
 Memorial Sloan-Kettering Cancer Center  
 Mark S. Kaminski, MD†  
 University of Michigan Comprehensive Cancer Center  
 Youn H. Kim, MD‡  
 Stanford Comprehensive Cancer Center  
 Ann S. LaCasce, MD†  
 Dana-Farber/Brigham and Women's Cancer Center  
 Tariq I. Mughal, MD†‡  
 St. Jude Children's Research Hospital/  
 University of Tennessee Cancer Institute

Auyporn Nademanee, MD†‡§  
 City of Hope Comprehensive Cancer Center  
 Pierluigi Porcu, MD‡P  
 The Ohio State University Comprehensive Cancer Center –  
 James Cancer Hospital and Solove Research Institute  
 Oliver Press, MD, PhD†  
 Fred Hutchinson Cancer Research Center/  
 Seattle Cancer Care Alliance  
 Leonard Prosnitz, MD§  
 Duke Comprehensive Cancer Center  
 Nashitha Reddy, MD‡§  
 Vanderbilt-Ingram Cancer Center  
 Mitchell R. Smith, MD, PhD†‡  
 Fox Chase Cancer Center  
 Lubomir Sokol, MD, PhD†‡P§  
 H. Lee Moffitt Cancer Center & Research Institute  
 Lode Swinnen, MB, ChB‡  
 The Sidney Kimmel Comprehensive Cancer Center at  
 Johns Hopkins  
 Julie M. Vose, MD‡§  
 UNMC Eppley Cancer Center at  
 The Nebraska Medical Center  
 William G. Wierda, MD, PhD‡  
 The University of Texas M. D. Anderson Cancer Center  
 Joachim Yahalom, MD§  
 Memorial Sloan-Kettering Cancer Center  
 Furhan Yunus, MD‡  
 St. Jude Children's Research Hospital/  
 University of Tennessee Cancer Institute

KEY:

\*Writing Committee Member

Specialties: †Medical Oncology; ‡Internal Medicine;  
 ‡Hematology/Hematology Oncology; ‡Pathology; §Bone  
 Marrow Transplantation; ¶Dermatology; §Radiotherapy/  
 Radiation Oncology

DIAGNOSIS<sup>a,b</sup>

## ESSENTIAL:

- Hematopathology review of all slides with at least one paraffin block representative of the tumor. Rebiopsy if consult material is nondiagnostic.
- An FNA or core needle biopsy alone is generally not suitable for the initial diagnosis of lymphoma. In certain circumstances, when a lymph node is not easily accessible for excisional or incisional biopsy, a combination of core biopsy and FNA biopsies in conjunction with appropriate ancillary techniques for the differential diagnosis (immunohistochemistry, flow cytometry, PCR for IgH and TCR gene rearrangements, and FISH for major translocations) may be sufficient for diagnosis.
- Adequate immunophenotyping to establish diagnosis<sup>c,d</sup>
  - ▶ Paraffin panel: CD45 (LCA), CD20, CD3, CD10, Ki-67, BCL2, BCL6, TdT
  - or
  - ▶ Cell surface marker analysis by flow cytometry: kappa/lambda, CD45, CD20, CD3, CD5, CD19, CD10, TdT
- Cytogenetics or FISH: t(8;14) or variants; MYC; IgH; BCL2; BCL6 rearrangements

## USEFUL UNDER CERTAIN CIRCUMSTANCES:

- Additional immunohistochemical studies to establish lymphoma subtype
  - ▶ Frozen: kappa/lambda
  - ▶ Paraffin panel: TdT, kappa/lambda, ISH for EBER
- Molecular genetic analysis to detect: antigen receptor gene rearrangements; MYC rearrangement

## WORKUP

## ESSENTIAL:

- Physical exam: attention to node-bearing areas, including Waldeyer's ring, and to size of liver and spleen
- Performance status
- B symptoms
- CBC, differential, platelets
- LDH
- Comprehensive metabolic panel
- Uric acid
- Chest/abdominal/pelvic CT with contrast of diagnostic quality
- Lumbar puncture
- Unilateral or bilateral bone marrow biopsy ± aspirate
- HIV testing
- Hepatitis B testing<sup>e</sup>
- MUGA scan/echocardiogram<sup>f</sup>
- Pregnancy testing in women of child-bearing age (if chemotherapy planned)

## USEFUL IN SELECTED CASES:

- Neck CT
- Discussion of fertility issues and sperm banking
- Beta-2-microglobulin
- PET-CT scan<sup>g</sup>
- Flow cytometry of cerebrospinal fluid

<sup>a</sup>WHO 2008 classification recognizes that it may not always be possible to distinguish between DLBCL and Burkitt's lymphoma. Where it is not possible to distinguish, aggressive therapy per this guideline is appropriate in selected cases.

<sup>b</sup>This disease is complex and curative; it is preferred that treatment occur at centers with expertise in the management of the disease.

<sup>c</sup>Typical immunophenotype: slg+, CD10+, CD20+, TdT-, Ki67+ (100%), BCL2-, BCL6+, MYC rearrangement only by cytogenetics or FISH.

<sup>d</sup>See Use of Immunophenotyping in Differential Diagnosis of Mature B-cell and T/NK-cell Neoplasms (pages 301-308).

<sup>e</sup>Hepatitis B testing is indicated because of the risk for reactivation with immunotherapy + chemotherapy. Tests include hepatitis B surface antigen and core antibody for patients with no risk factors. For patients with risk factors or previous history of hepatitis B, add e-antigen. If positive, check viral load and consult with gastroenterologist.

<sup>f</sup>If treatment includes regimens containing anthracyclines or anthracenediones.

<sup>g</sup>Initiation of therapy should not be delayed in order to obtain a PET-CT scan.

Non-Hodgkin's Lymphomas Version 1:2010

BURKITT'S LYMPHOMA

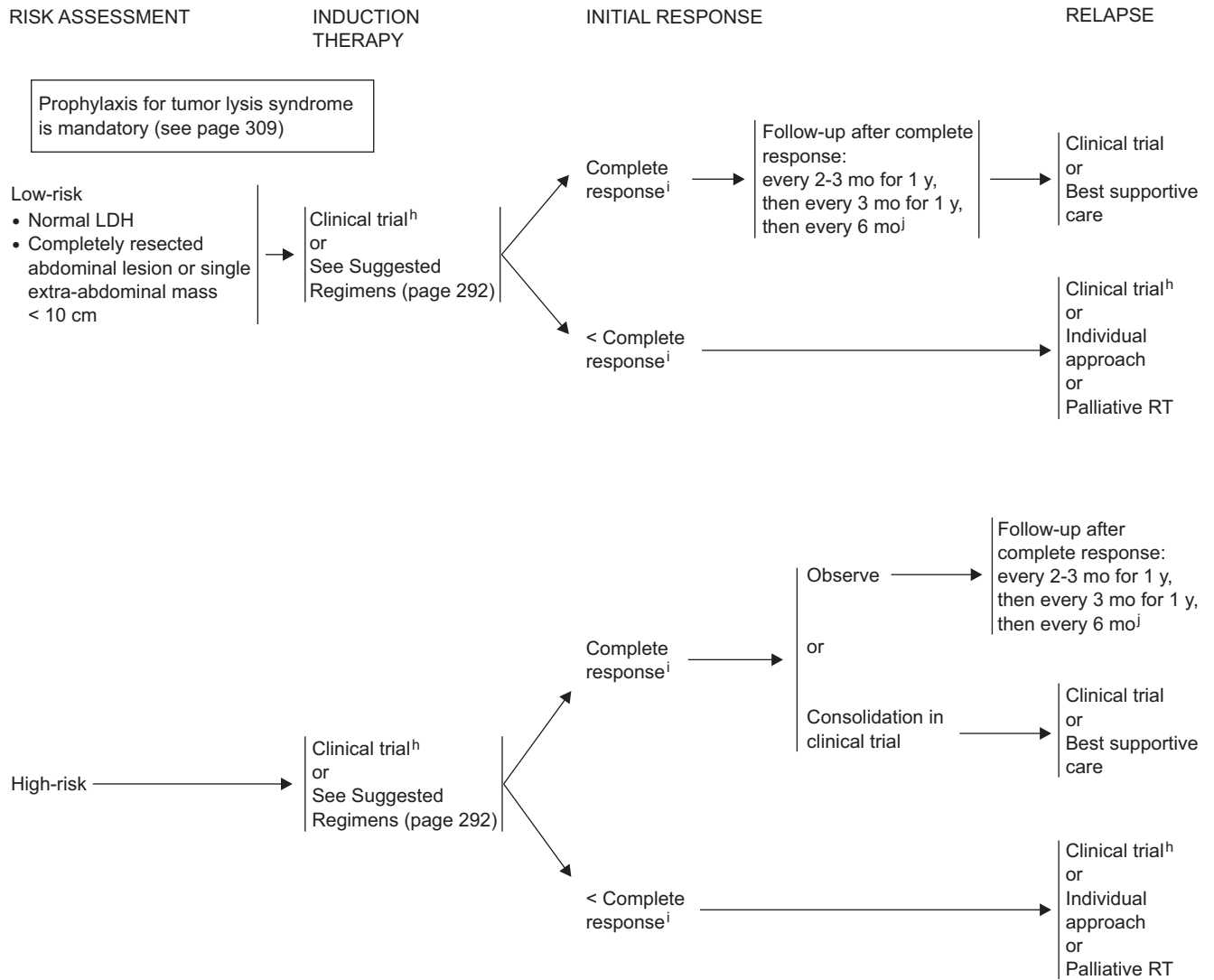

<sup>h</sup>Clinical trials may include high dose therapy with allogeneic or autologous stem cell rescue.  
<sup>i</sup>See Response Criteria for Lymphoma (pages 310 and 311).  
<sup>j</sup>Relapse after 2 years is rare; therefore, follow-up should be individualized according to patient characteristics.

SUGGESTED TREATMENT REGIMENS<sup>a</sup>  
(in alphabetical order)

CHOP is not adequate therapy.

Low-Risk: Combination Regimens

- CALGB 9251 regimen (cyclophosphamide and prednisone followed by cycles containing either ifosfamide or cyclophosphamide; high-dose methotrexate, leucovorin, vincristine, dexamethasone, and either doxorubicin, etoposide, or cytarabine; or intrathecal triple therapy [methotrexate, cytarabine, and hydrocortisone])
- CODOX-M (original or modified; cyclophosphamide, doxorubicin, vincristine with intrathecal methotrexate and cytarabine followed by high-dose systemic methotrexate) ± rituximab (3 cycles)
- Dose-adjusted EPOCH<sup>b</sup> (etoposide, prednisone, vincristine, cyclophosphamide, doxorubicin) + rituximab (minimum 3 cycles with one additional cycle beyond CR). Regimen includes intrathecal methotrexate.
- HyperCVAD (cyclophosphamide, vincristine, doxorubicin, and dexamethasone) alternating with high-dose methotrexate and cytarabine + rituximab

High-Risk: Combination Regimens

- CALGB 9251 regimen (cyclophosphamide and prednisone followed by cycles containing either ifosfamide or cyclophosphamide; high-dose methotrexate, leucovorin, vincristine, dexamethasone, and either doxorubicin, etoposide, or cytarabine; or intrathecal triple therapy [methotrexate, cytarabine, and hydrocortisone] with prophylactic CNS irradiation in select patients)
- CODOX-M (original or modified; cyclophosphamide, doxorubicin, vincristine with intrathecal methotrexate and cytarabine followed by high-dose systemic methotrexate) alternating with IVAC (ifosfamide, cytarabine, etoposide, and intrathecal methotrexate) ± rituximab
- Dose-adjusted EPOCH (etoposide, prednisone, vincristine, cyclophosphamide, doxorubicin) + rituximab (for high-risk patients not able to tolerate aggressive treatments). Regimen includes intrathecal methotrexate.
- HyperCVAD (cyclophosphamide, vincristine, doxorubicin, and dexamethasone) alternating with high-dose methotrexate and cytarabine ± rituximab

Consider SCT for patients in relapse

See Rituximab and Viral Reactivation (page 312)

<sup>a</sup>See references for regimens on facing page.

<sup>b</sup>Data are for patients without CNS disease.

SUGGESTED TREATMENT REGIMENS  
References

**Low-Risk: Combination Regimens****CALGB 9251**

Lee EJ, Petroni GR, Schiffer CA, et al. Brief-duration high-intensity chemotherapy for patients with small noncleaved-cell lymphoma or FAB L3 acute lymphocytic leukemia: results of Cancer and Leukemia Group B study 9251. *J Clin Oncol* 2001;19:4014-4022.  
Rizzieri DA, Johnson JL, Niedzwiecki D, et al. Intensive chemotherapy with and without cranial radiation for Burkitt leukemia and lymphoma: final results of Cancer and Leukemia Group B study 9251. *Cancer* 2004;100:1438-1448.

**CODOX-M (original or modified; cyclophosphamide, doxorubicin, vincristine with intrathecal methotrexate and cytarabine followed by high-dose systemic methotrexate) ± rituximab**

LaCasce A, Howard O, Lib S, et al. Modified magrath regimens for adults with Burkitt and Burkitt-like lymphoma: preserved efficacy with decreased toxicity. *Leuk Lymphoma* 2004;45:761-767.

Mead GM, Sydes MR, Walewski J, et al. An international evaluation of CODOX-M and CODOX-M alternating with IVAC in adult Burkitt's lymphoma: results of United Kingdom Lymphoma Group LY06 study. *Ann Oncol* 2002;13:1264-1274.

**Dose-adjusted EPOCH plus rituximab (regimen includes IT methotrexate)**

Dunleavy K, Little, RF, Pittaluga S, et al. A prospective study of dose-adjusted (DA) EPOCH with rituximab in adult patients with newly diagnosed Burkitt lymphoma: a regimen with high efficacy and low toxicity [abstract]. *Ann Oncol* 2008;19(Suppl 4):iv83-84. Abstract 9.

**HyperCVAD (cyclophosphamide, vincristine, doxorubicin, and dexamethasone) alternating with high-dose methotrexate and cytarabine + rituximab**

Thomas DA, Faderl S, O'Brien S, et al. Chemoimmunotherapy with hyper-CVAD plus rituximab for the treatment of adult Burkitt and Burkitt-type lymphoma or acute lymphoblastic leukemia. *Cancer* 2006;106:1569-1580.

**High-Risk: Combination Regimens****CALGB 9251**

Lee EJ, Petroni GR, Schiffer CA, et al. Brief-duration high-intensity chemotherapy for patients with small noncleaved-cell lymphoma or FAB L3 acute lymphocytic leukemia: results of Cancer and Leukemia Group B study 9251. *J Clin Oncol* 2001;19:4014-4022.  
Rizzieri DA, Johnson JL, Niedzwiecki D, et al. Intensive chemotherapy with and without cranial radiation for Burkitt leukemia and lymphoma: final results of Cancer and Leukemia Group B study 9251. *Cancer* 2004;100:1438-1448.

**CODOX-M (original or modified; cyclophosphamide, doxorubicin, vincristine with intrathecal methotrexate and cytarabine followed by high-dose systemic methotrexate) alternating with IVAC (ifosfamide, cytarabine, etoposide and intrathecal methotrexate) ± rituximab**

LaCasce A, Howard O, Lib S, et al. Modified magrath regimens for adults with Burkitt and Burkitt-like lymphoma: preserved efficacy with decreased toxicity. *Leuk Lymphoma* 2004;45:761-767.

Mead GM, Sydes MR, Walewski J, et al. An international evaluation of CODOX-M and CODOX-M alternating with IVAC in adult Burkitt's lymphoma: results of United Kingdom Lymphoma Group LY06 study. *Ann Oncol* 2002;13:1264-1274.

**Dose-adjusted EPOCH plus rituximab (regimen includes IT methotrexate)**

Dunleavy K, Little, RF, Pittaluga S, et al. A prospective study of dose-adjusted (DA) EPOCH with rituximab in adult patients with newly diagnosed Burkitt lymphoma: a regimen with high efficacy and low toxicity [abstract]. *Ann Oncol* 2008;19(Suppl 4):iv83-iv84. Abstract 9.

**HyperCVAD (cyclophosphamide, vincristine, doxorubicin, and dexamethasone) alternating with high-dose methotrexate and cytarabine ± rituximab**

Thomas DA, Faderl S, O'Brien S, et al. Chemoimmunotherapy with hyper-CVAD plus rituximab for the treatment of adult Burkitt and Burkitt-type lymphoma or acute lymphoblastic leukemia. *Cancer* 2006;106:1569-1580.

DIAGNOSIS<sup>a</sup>

## ESSENTIAL:

- Hematopathology review of all slides with at least one paraffin block representative of the tumor. Rebiopsy if consult material is nondiagnostic.
- An FNA or core needle biopsy alone is not generally suitable for the initial diagnosis of lymphoma. In certain circumstances, when a lymph node is not easily accessible for excisional or incisional biopsy, a combination of core biopsy and FNA biopsies in conjunction with appropriate ancillary techniques for the differential diagnosis (immunohistochemistry, flow cytometry, PCR for IgH and TCR gene rearrangements, and FISH for major translocations) may be sufficient for diagnosis.
- Adequate immunophenotyping to establish diagnosis<sup>b,c</sup>
  - ▶ Paraffin panel: CD45 (LCA), CD20, CD79a, CD3, CD2, CD5, TdT, CD1a, CD10, cyclin D1
  - or
  - ▶ Cell surface marker analysis by flow cytometry: kappa/lambda, CD45, CD3, CD5, CD4, CD7, CD8, CD19, CD20, CD10, TdT, CD13, CD33, CD1a, cytoplasmic CD3, CD22, myeloperoxidase

## USEFUL UNDER CERTAIN CIRCUMSTANCES:

- Additional immunohistochemical studies to establish lymphoma subtype
  - ▶ Frozen: kappa/lambda
  - ▶ Paraffin panel: CD22, CD4, CD8, cyclin D1
- Molecular genetic analysis to detect antigen receptor gene rearrangements
- Cytogenetics or FISH: MYC; t(9;22); t(8;14) and variants

## WORKUP

## ESSENTIAL:

- Physical exam: attention to node-bearing areas, including Waldeyer's ring, and to size of liver and spleen
- Performance status
- B symptoms
- CBC, differential, platelets
- LDH
- Comprehensive metabolic panel
- Uric acid, phosphate
- Chest/abdominal/pelvic CT with contrast of diagnostic quality
- Lumbar puncture
- Bilateral or unilateral bone marrow biopsy ± aspirate with flow and cytogenetics
- Hepatitis B testing<sup>d</sup>
- MUGA scan/echocardiogram<sup>e</sup>
- Pregnancy testing in women of child-bearing age (if chemotherapy planned)

## USEFUL IN SELECTED CASES:

- Head MRI
- Discussion of fertility issues and sperm banking
- Beta-2-microglobulin
- PET-CT scan<sup>f</sup>
- Flow cytometry of cerebrospinal fluid

<sup>a</sup>This disease is complex and curative; it is preferred that treatment occur at centers with expertise in the management of the disease.

<sup>b</sup>Typical immunophenotype: LBL-B: slg-, CD10+/-, CD19+, CD20-/+ , TdT+. LBL-T: slg-, CD10-, CD19/20-, CD3-/+ , CD4/8+/-, CD1a+/-, TdT+, CD2+, CD7+.

<sup>c</sup>See Use of Immunophenotyping in Differential Diagnosis of Mature B-Cell and T/NK-Cell Neoplasms (pages 301-308).

<sup>d</sup>Hepatitis B testing is indicated because of the risk for reactivation with immunotherapy + chemotherapy. Tests include hepatitis B surface antigen and core antibody for a patient with no risk factors. For patients with risk factors or previous history of hepatitis B, add e-antigen. If positive, check viral load and consult with gastroenterologist.

<sup>e</sup>If treatment includes regimens containing anthracyclines or anthracenediones.

<sup>f</sup>Initiation of therapy should not be delayed in order to obtain a PET-CT scan.

Non-Hodgkin's Lymphomas Version 1:2010

LYMPHOBLASTIC LYMPHOMA

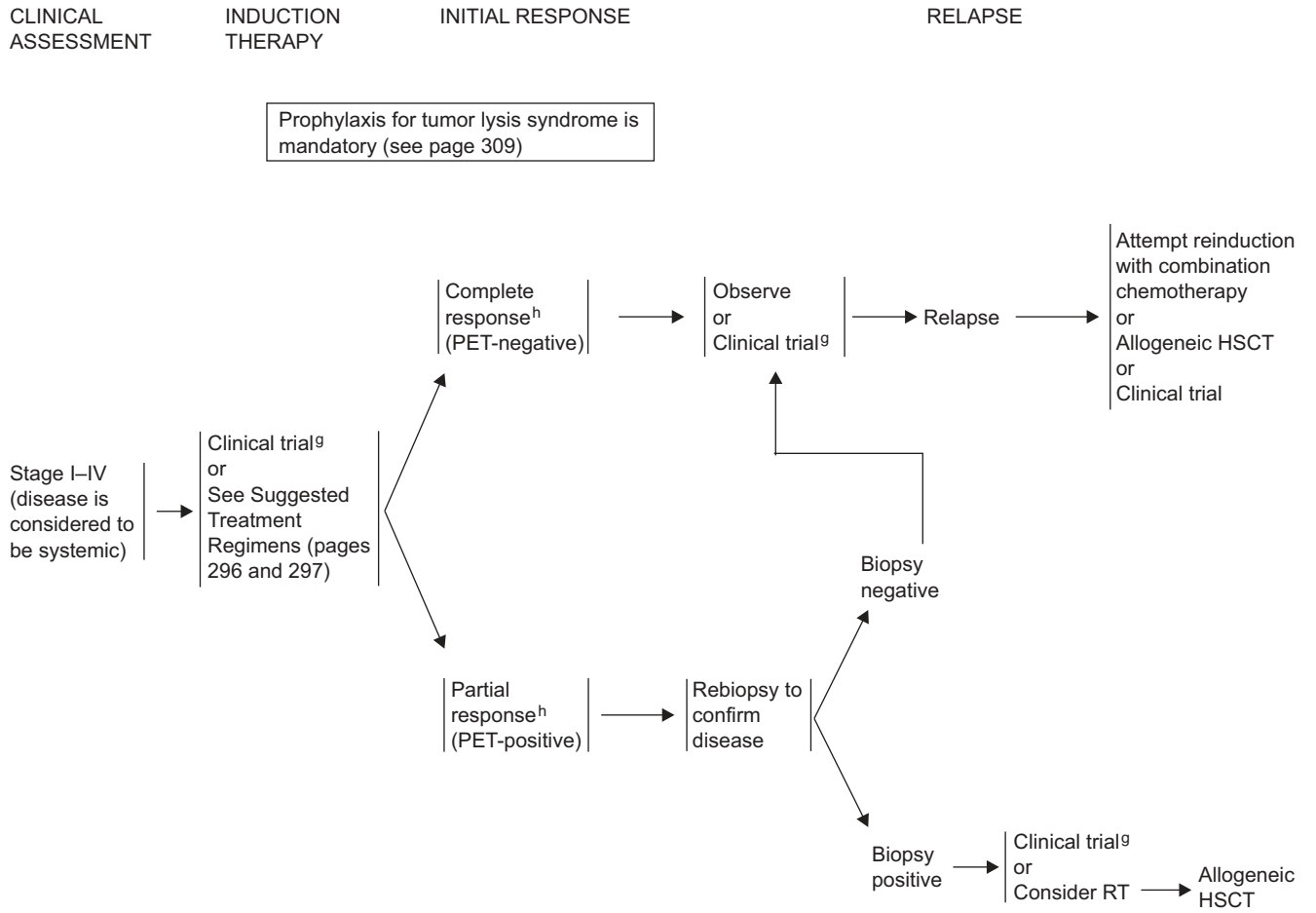

<sup>g</sup>For poor-risk patients, consideration of high-dose therapy with autologous or allogeneic stem cell rescue is appropriate.  
<sup>h</sup>See Response Criteria for Lymphoma (pages 310 and 311).



SUGGESTED TREATMENT REGIMENS<sup>a</sup>  
(in alphabetical order)

**BFM (Berlin–Frankfurt–Munster)**

• **Standard BFM Regimen:**

- ▶ Induction phase:
  - ◊ Vincristine, daunomycin, prednisone, L-asparaginase, cytarabine (IT), methotrexate (IT)
- ▶ Consolidation phase (5 wk):
  - ◊ Prednisone, cyclophosphamide, mercaptopurine, vincristine, cytarabine, methotrexate (IT), RT
- ▶ Interim maintenance phase (8 wk):
  - ◊ Mercaptopurine and methotrexate (PO)
- ▶ Delayed intensification (7 wk):
  - ◊ Reinduction phase (4 wk):
    - Dexamethasone, vincristine, doxorubicin
  - ◊ Reconsolidation phase (3 wk):
    - L-asparaginase, vincristine, cyclophosphamide, thioguanine, cytarabine, intrathecal methotrexate
- ▶ Long-term maintenance (12 wk):
  - ◊ Vincristine, prednisone, mercaptopurine, methotrexate (PO and IT)

• **Augmented BFM Regimen:**

- ▶ Induction I:
  - ◊ Prednisone, vincristine, daunorubicin, L-asparaginase, methotrexate (IT)
- ▶ Induction II:
  - ◊ Cyclophosphamide, cytarabine, 6-mercaptopurine, methotrexate (IT)
- ▶ Consolidation I:
  - ◊ Cytarabine, mitoxantrone, methotrexate, asparaginase, 6-mercaptopurine
- ▶ Reinduction I
  - ◊ Prednisolone, vincristine, doxorubicin
  - ◊ Triple prophylaxis: methotrexate, cytarabine, dexamethasone
- ▶ Reinduction II
  - ◊ Cyclophosphamide, cytarabine, 6-thioguanine
  - ◊ Triple prophylaxis: methotrexate, cytarabine, dexamethasone
- ▶ Consolidation II
  - ◊ Etoposide, cytarabine
  - ◊ Cyclophosphamide, cytarabine

• **CALGB ALL Regimen**

- ▶ Induction therapy (4 wk):
  - ◊ Cyclophosphamide, daunorubicin, vincristine, prednisone, L-asparaginase
  - ◊ For patients ≥ 60 years: cyclophosphamide, daunorubicin, prednisone
- ▶ Early intensification (4 wk):
  - ◊ Intrathecal methotrexate, cyclophosphamide, 6-mercaptopurine, cytarabine, vincristine, L-asparaginase
- ▶ CNS prophylaxis and interim maintenance:
  - ◊ Cranial irradiation in select cases, methotrexate (IT), 6-mercaptopurine, methotrexate (PO)
- ▶ Late intensification (8 wk):
  - ◊ Doxorubicin, vincristine, dexamethasone, cyclophosphamide, 6-thioguanine, cytarabine
- ▶ Prolonged maintenance (until 24 mo from diagnosis):
  - ◊ Vincristine, prednisone, methotrexate (PO), 6-mercaptopurine

• **Hyper-CVAD<sup>b</sup>** (cyclophosphamide, vincristine, doxorubicin, dexamethasone) alternating with methotrexate + cytarabine, including intrathecal methotrexate

- ▶ Maintenance therapy
  - ◊ 6-mercaptopurine, methotrexate, vincristine, prednisone (POMP)
- ▶ In cases of CD20+ (≥ 20%) acute lymphoblastic lymphoma (ALL), the addition of rituximab should be considered.
- ▶ In cases of Philadelphia chromosome-positive ALL, imatinib should be incorporated into regimen.

• **LMB-86 Regimen**

- ▶ Cytoreductive therapy
  - ◊ COP (cyclophosphamide, vincristine, prednisone)
- ▶ Induction therapy
  - ◊ COPADM (cyclophosphamide, vincristine, prednisone, doxorubicin, high-dose methotrexate)
- ▶ Consolidation therapy
  - ◊ CYVE (cytarabine and etoposide; regimen includes high-dose cytarabine)

• **Maintenance Chemotherapy**

- ▶ Up to 2 y of maintenance based on the treatment protocol is recommended

<sup>a</sup>See references for regimens on facing page.

<sup>b</sup>For T-cell lymphoblastic lymphomas with primary mediastinal presentation, residual masses are irradiated.

SUGGESTED TREATMENT REGIMENS  
References**BFM (Berlin–Frankfurt–Munster)****Standard BFM**

Stock W, La M, Sanford B, et al. What determines the outcomes for adolescents and young adults with acute lymphoblastic leukemia treated on cooperative group protocols? A comparison of Children's Cancer Group and Cancer and Leukemia Group B studies. *Blood* 2008;112:1646-1654.

**Augmented BFM**

Hoelzer D, Gokbuget N, Digel W, et al. Outcome of adult patients with T-lymphoblastic lymphoma treated according to protocols for acute lymphoblastic leukemia. *Blood* 2002;99:4379-4385.

**CALGB ALL**

Larson R, Dodge R, Burns C, et al. A five-drug remission induction regimen with intensive consolidation for adults with acute lymphoblastic leukemia: cancer and leukemia group B study 8811. *Blood* 1995;85:2025-2037.

**Hyper-CVAD (cyclophosphamide, vincristine, doxorubicin, and dexamethasone alternating with high-dose methotrexate-cytarabine) followed by POMP (mercaptopurine, methotrexate, vincristine, and prednisone) maintenance**  
Kantarjian HM, O'Brien S, Smith TL, et al. Results of treatment with hyper-CVAD, a dose-intensive regimen, in adult acute lymphocytic leukemia. *J Clin Oncol* 2000;18:547-561.

Thomas DA, O'Brien S, Cortes J, et al. Outcome with the hyper-CVAD regimens in lymphoblastic lymphoma. *Blood* 2004;104:1624-1630.

**LMB-86**

Soussain C, Patte C, Ostronoff M, et al. Small noncleaved cell lymphoma and leukemia in adults. A retrospective study of 65 adults treated with the LMB pediatric protocols. *Blood* 1995;85:664-674.

## AIDS-RELATED B-CELL LYMPHOMAS Non-Hodgkin's Lymphomas Version 1:2010

### DIAGNOSIS

#### ESSENTIAL:

- Hematopathology review of all slides with at least one paraffin block representative of the tumor. Rebiopsy if consult material is nondiagnostic.
- An FNA or core needle biopsy alone is not generally suitable for the initial diagnosis of lymphoma. In certain circumstances, when a lymph node is not easily accessible for excisional or incisional biopsy, a combination of core biopsy and FNA biopsies in conjunction with appropriate ancillary techniques for the differential diagnosis (immunohistochemistry, flow cytometry, PCR for IgH and TCR gene rearrangements, and FISH for major translocations) may be sufficient for diagnosis.
- Adequate immunophenotyping to establish diagnosis<sup>a</sup>
  - ▶ Recommended panel for paraffin section immunohistochemistry: CD45 (LCA), CD20, CD3, CD10, BCL2, BCL6, Ki-67, CD138, kappa/lambda, HHV8 or
  - ▶ Cell surface marker analysis by flow cytometry: kappa/lambda, CD45, CD3, CD5, CD19, CD10, TdT, CD14, CD20
- Epstein-Barr virus (EBER-ISH)

#### USEFUL UNDER CERTAIN CIRCUMSTANCES:

- Additional immunohistochemical studies to establish lymphoma subtype
  - ▶ DLBCL, Burkitt's, plasmablastic, primary effusion: CD10, BCL2, Ki-67, BCL6, CD138
- Molecular genetic analysis to detect: antigen receptor gene rearrangements; BCL2, BCL6, MYC rearrangements
- Cytogenetics or FISH, BCL2, BCL6, MYC

### WORKUP

#### ESSENTIAL:

- Physical exam: attention to node-bearing areas, including Waldeyer's ring, and to size of liver and spleen
- Performance status
- B symptoms
- CBC, differential, platelets
- LDH
- Comprehensive metabolic panel
- Uric acid, phosphate
- Chest/abdominal/pelvic CT with contrast of diagnostic quality
- PET-CT scan
- Bone marrow biopsy ± aspirate
- CD4 count
- LP
- Viral load
- Hepatitis B testing<sup>b</sup>
- MUGA scan/echocardiogram<sup>c</sup>
- Pregnancy testing in women of child-bearing age (if chemotherapy planned)

#### USEFUL IN SELECTED CASES:

- UGI/barium enema/endoscopy
- Neck CT
- Plain bone radiographs and bone scan
- Discussion of fertility issues and sperm banking
- Stool guaiac, if anemic
- Beta-2-microglobulin
- Brain MRI with gadolinium, or head CT

<sup>a</sup>See Use of Immunophenotyping in Differential Diagnosis of Mature B-Cell and T/NK-Cell Neoplasms (pages 301-308).

<sup>b</sup>Hepatitis B testing is indicated because of the risk for reactivation with immunotherapy + chemotherapy. Tests include hepatitis B surface antigen and core antibody for a patient with no risk factors. For patients with risk factors or previous history of hepatitis B, add e-antigen. If positive, check viral load and consult with gastroenterologist.

<sup>c</sup>If treatment includes regimens containing anthracyclines or anthracenediones.

Non-Hodgkin's Lymphomas Version 1:2010 AIDS-RELATED B-CELL LYMPHOMAS

TREATMENT AND FOLLOW-UP

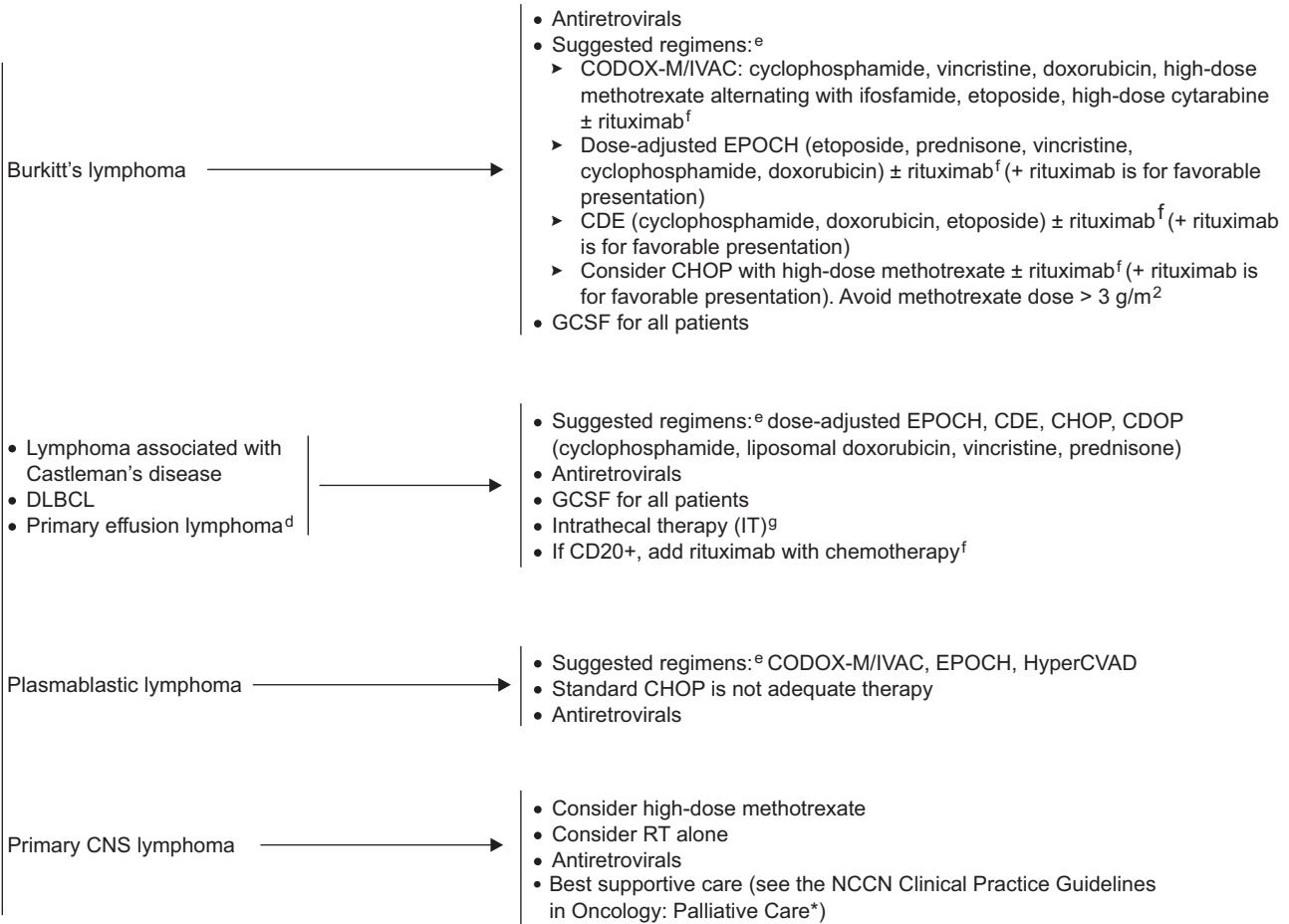

See Rituximab and Viral Reactivation (page 312)

\*To view the most recent version of these guidelines, visit the NCCN Web site at [www.NCCN.org](http://www.NCCN.org).

<sup>d</sup>Most cases are CD20-negative and addition of rituximab is not indicated.  
<sup>e</sup>See references for regimens page 300.  
<sup>f</sup>Patients on active antiretrovirals with persistently low CD4 count of < 100 tend to have poor prognosis and higher risk for infection associated with the addition of rituximab. Spina M, Jaeger U, Sparano JA, et al. Rituximab plus infusional cyclophosphamide, doxorubicin, and etoposide in HIV-associated non-Hodgkin lymphoma: pooled results from 3 phase 2 trials. Blood 2005;105:1891-1897.  
<sup>g</sup>Prophylactic IT methotrexate is used at some institutions for all patients. At other NCCN institutions, patients with HIV-associated DLBCL receive IT methotrexate in selective settings (paranasal sinus, testicular, epidural, bone marrow with large cell lymphoma, HIV-lymphoma, or ≥ 2 extranodal sites).

SUGGESTED TREATMENT REGIMENS  
References**CHOP (cyclophosphamide, doxorubicin, vincristine, prednisone)**

Ratner L, Lee J, Tang S, et al. Chemotherapy for human immunodeficiency virus-associated non-Hodgkin's lymphoma in combination with highly active antiretroviral therapy. *J Clin Oncol* 2001;19:2171-2178.

**CDE (cyclophosphamide, doxorubicin, etoposide)**

Sparano JA, Lee S, Chen MG, et al. Phase II trial of infusional cyclophosphamide, doxorubicin, and etoposide in patients with HIV-associated non-Hodgkin's lymphoma: an Eastern Cooperative Oncology Group trial (E1494). *J Clin Oncol* 2004;22:1491-1500.

**CDE + Rituximab**

Spina M, Jaeger U, Sparano JA, et al. Rituximab plus infusional cyclophosphamide, doxorubicin, and etoposide in HIV-associated non-Hodgkin lymphoma: pooled results from 3 phase 2 trials. *Blood* 2005;105:1891-1897.

Spina M, Simonelli C, Vaccher E, et al. Long-term follow-up of rituximab and infusional cyclophosphamide, doxorubicin, and etoposide (CDE) in combination with HAART in HIV-related non-Hodgkin's lymphomas (NHL) [abstract]. *Blood* 2008;112:Abstract 1467.

**EPOCH (etoposide, prednisone, vincristine, cyclophosphamide, doxorubicin)**

Little RF, Pittaluga S, Grant N, et al. Highly effective treatment of acquired immunodeficiency syndrome-related lymphoma with dose-adjusted EPOCH: impact of antiretroviral therapy suspension and tumor biology. *Blood* 2003;101:4653-4659.

**CODOX-M/IVAC (cyclophosphamide, vincristine, doxorubicin, high-dose methotrexate alternating with ifosfamide, etoposide, high-dose cytarabine)**

Wang ES, Straus DJ, Teruya-Feldstein J, et al. Intensive chemotherapy with cyclophosphamide, doxorubicin, high-dose methotrexate/ifosfamide, etoposide, and high-dose cytarabine (CODOX-M/IVAC) for human immunodeficiency virus-associated Burkitt lymphoma. *Cancer* 2003;98:1196-1205.

USE OF IMMUNOPHENOTYPING IN DIFFERENTIAL DIAGNOSIS OF MATURE B-CELL AND T/NK-CELL NEOPLASMS<sup>a</sup>  
(TO BE USED IN CONJUNCTION WITH CLINICAL PATHOLOGICAL CORRELATION)

B-CELL ANTIGENS POSITIVE (CD19, CD20, CD79a, PAX5)

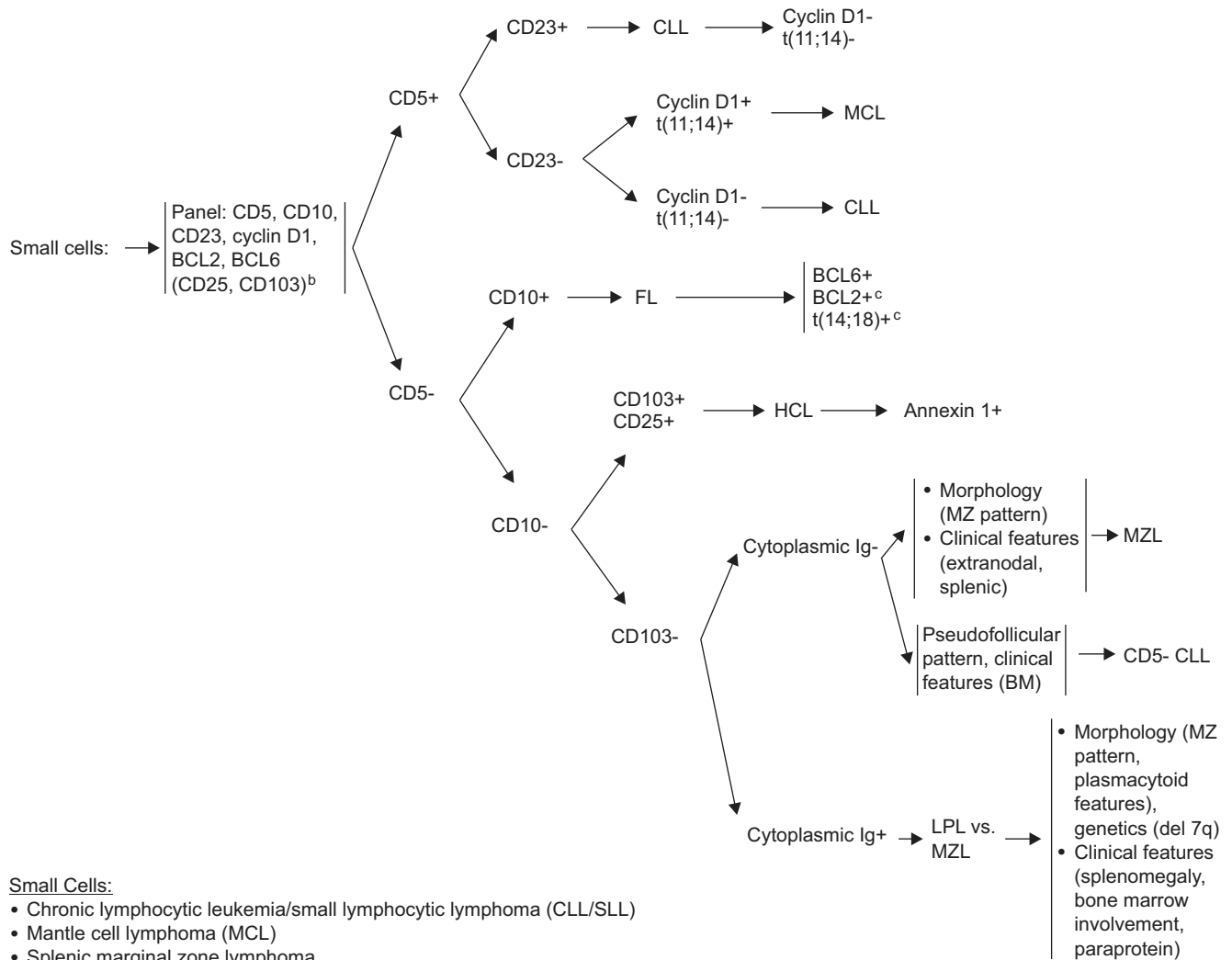

**Small Cells:**

- Chronic lymphocytic leukemia/small lymphocytic lymphoma (CLL/SLL)
- Mantle cell lymphoma (MCL)
- Splenic marginal zone lymphoma
- Hairy cell leukemia (HCL)
- Lymphoplasmacytic lymphoma (LPL)
- Extranodal marginal zone lymphoma (MALT lymphoma)
- Nodal marginal zone lymphoma
- Follicular lymphoma (FL)

<sup>a</sup>These are meant to be general guidelines. Interpretation of results should be based on individual circumstances and may vary. Not all tests will be required in every case.

<sup>b</sup>Flow cytometry, blood or bone marrow, if HCL is in differential diagnosis.

<sup>c</sup>85% of follicular lymphoma will be BCL2+ or t(14;18)+.

USE OF IMMUNOPHENOTYPING IN DIFFERENTIAL DIAGNOSIS OF MATURE B-CELL AND T/NK-CELL NEOPLASMS<sup>a</sup>  
(TO BE USED IN CONJUNCTION WITH CLINICAL PATHOLOGICAL CORRELATION)

B-CELL ANTIGENS-POSITIVE (CD19, CD20, CD79a, PAX5)

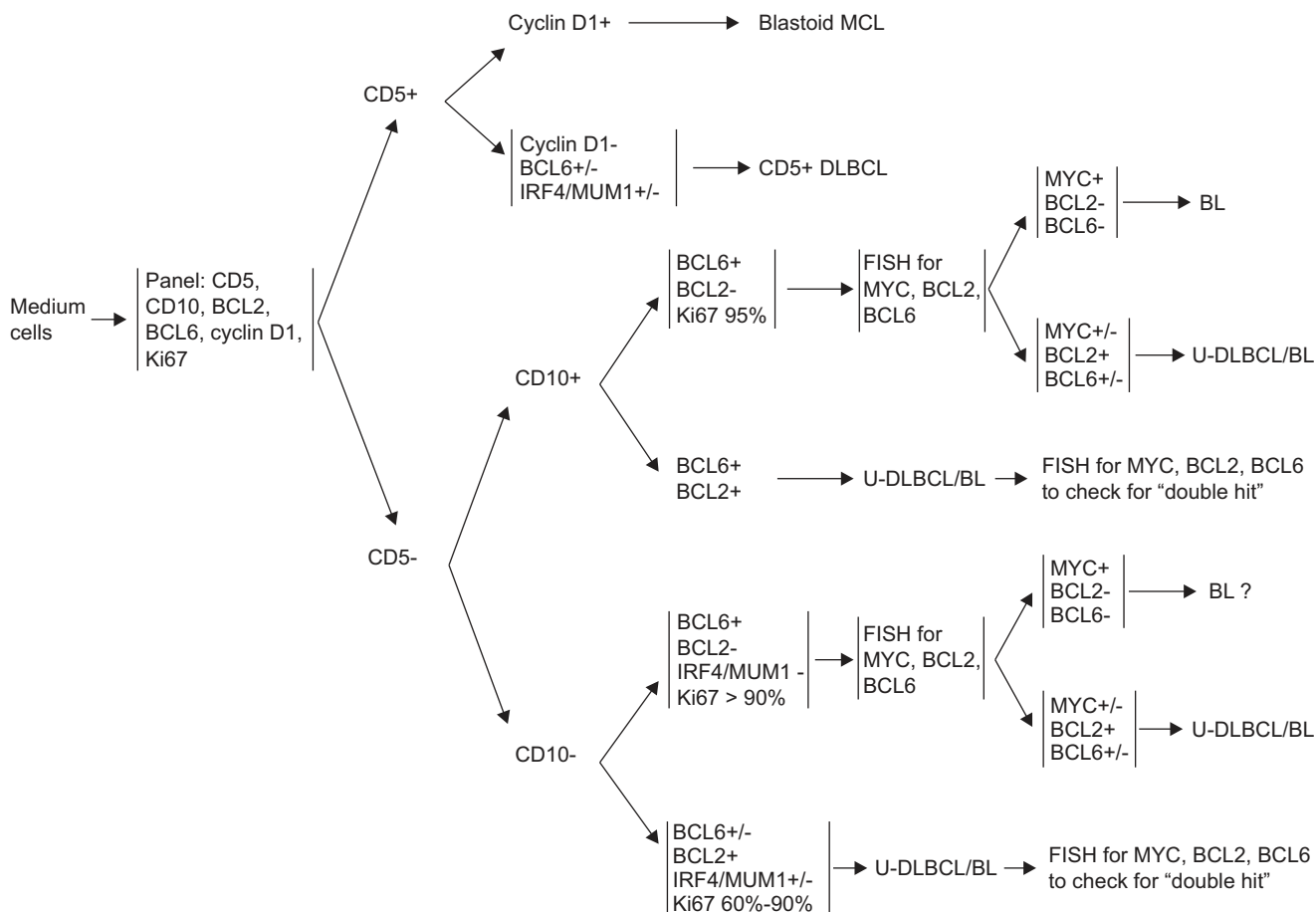

Medium cells

- Burkitt's lymphoma (BL)
- Diffuse large B-cell lymphoma (DLBCL)
- Mantle cell lymphoma (MCL), blastoid variant
- B-cell lymphoma (BCL), unclassifiable, intermediate between DLBCL and BL (U-DLBCL/BL)

<sup>a</sup>These are meant to be general guidelines. Interpretation of results should be based on individual circumstances and may vary. Not all tests will be required in every case.

USE OF IMMUNOPHENOTYPING IN DIFFERENTIAL DIAGNOSIS OF MATURE B-CELL AND T/NK-CELL NEOPLASMS<sup>a</sup>  
(TO BE USED IN CONJUNCTION WITH CLINICAL PATHOLOGICAL CORRELATION)

B-CELL ANTIGEN-POSITIVE (CD19, CD20, CD79a, PAX5)

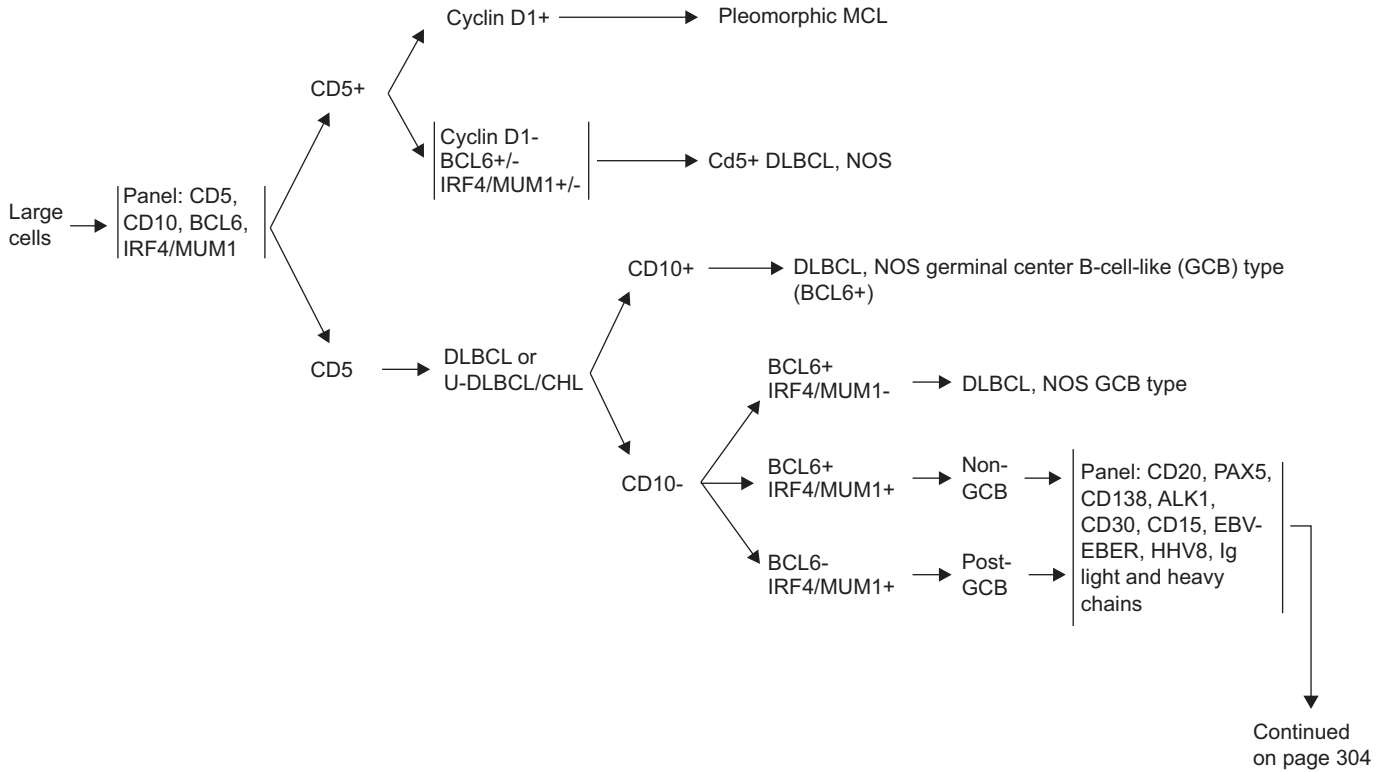

Large cells:

- Diffuse large B-cell lymphoma (DLBCL), NOS
  - T-cell/histiocyte rich large B-cell lymphoma (THRLBCL)
  - Primary DLBCL of the CNS
  - Primary cutaneous DLBCL, leg type
  - EBV+ DLBCL of the elderly (EBV+ DLBCL)
- DLBCL associated with chronic inflammation
- Lymphomatoid granulomatosis
- Primary mediastinal (thymic) large B-cell lymphoma (PMBL)
- Intravascular large B-cell lymphoma
- ALK+ large B-cell lymphoma
- Plasmablastic lymphoma
- Large B-cell lymphoma arising in HHV8-associated multicentric Castleman disease (LBCL in HHV8+ MCD)
- Primary effusion lymphoma
- B-cell lymphoma, unclassifiable, intermediate between DLBCL (U-DLBCL) and classical Hodgkin lymphoma (CHL)
- Mantle cell lymphoma (MCL), pleomorphic variant

<sup>a</sup>These are meant to be general guidelines. Interpretation of results should be based on individual circumstances and may vary. Not all tests will be required in every case.



USE OF IMMUNOPHENOTYPING IN DIFFERENTIAL DIAGNOSIS OF MATURE B-CELL AND T/NK-CELL NEOPLASMS<sup>a</sup>  
(TO BE USED IN CONJUNCTION WITH CLINICAL PATHOLOGICAL CORRELATION)

Large cells (continued from page 303)

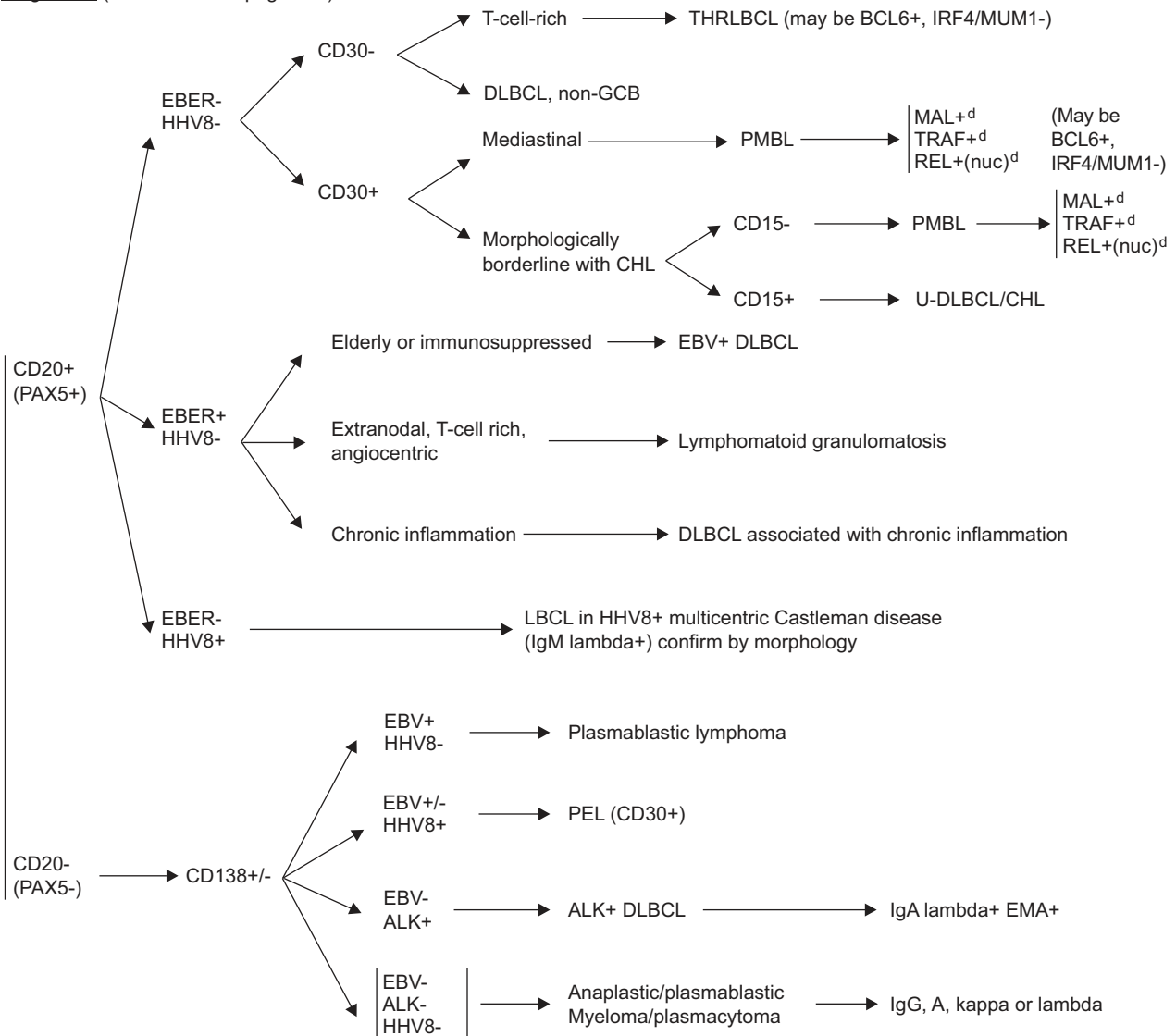

<sup>a</sup>These are meant to be general guidelines. Interpretation of results should be based on individual circumstances and may vary. Not all tests will be required in every case.

<sup>d</sup>These stains/studies are not routinely available.

USE OF IMMUNOPHENOTYPING IN DIFFERENTIAL DIAGNOSIS OF MATURE B-CELL AND T/NK-CELL NEOPLASMS<sup>a</sup>  
(TO BE USED IN CONJUNCTION WITH CLINICAL PATHOLOGICAL CORRELATION)

B-CELL ANTIGENS-POSITIVE (CD19, CD20, CD79a, PAX5)

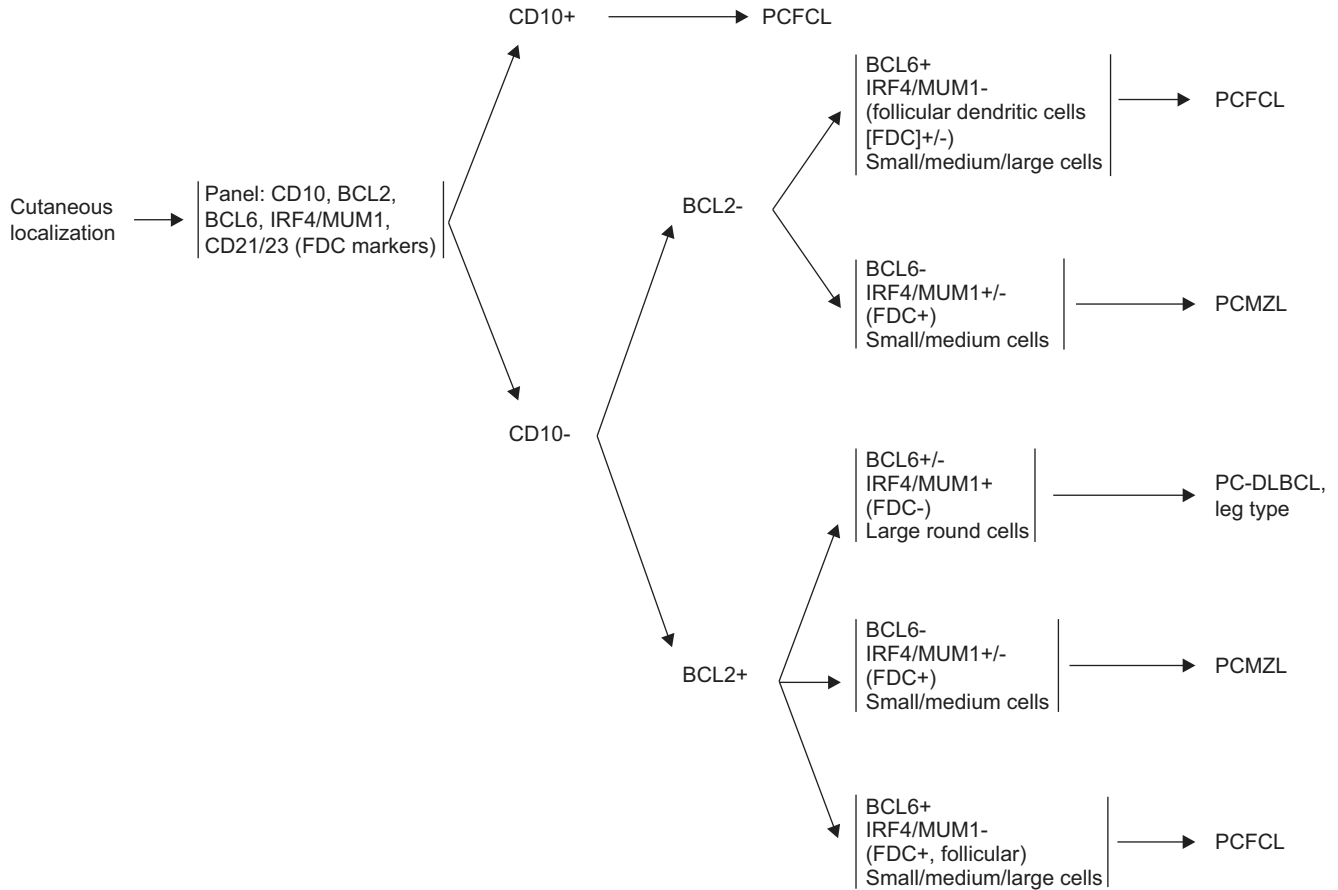

- Primary cutaneous marginal zone lymphoma (PCMZL)
- Primary cutaneous follicle center lymphoma (PCFCL)
- Primary cutaneous DLBCL, leg type (PC-DLBCL, leg type)

<sup>a</sup>These are meant to be general guidelines. Interpretation of results should be based on individual circumstances and may vary. Not all tests will be required in every case.

USE OF IMMUNOPHENOTYPING IN DIFFERENTIAL DIAGNOSIS OF MATURE B-CELL AND T/NK-CELL NEOPLASMS<sup>a</sup>  
(TO BE USED IN CONJUNCTION WITH CLINICAL PATHOLOGICAL CORRELATION)

T-CELL ANTIGENS-POSITIVE (CD2, CD3, CD5, CD7) [and B-cell antigens-negative]

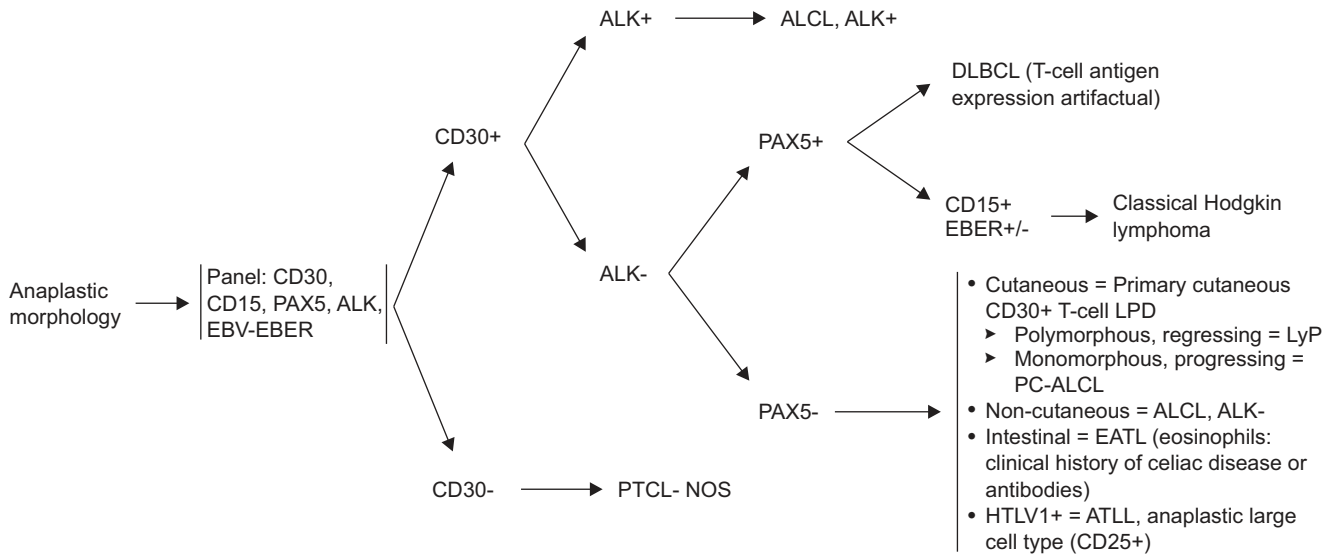

Anaplastic Morphology

- Anaplastic large cell lymphoma (ALCL), ALK+
- Anaplastic large cell lymphoma (ALCL), ALK-
- Adult T-cell leukemia/lymphoma (ATLL), anaplastic large cell type
- Enteropathy associated T-cell lymphoma (EATL)
- Primary cutaneous CD30+ T-cell lymphoproliferative disorders
  - ▶ Lymphomatoid papulosis (LyP)
  - ▶ Primary cutaneous anaplastic large cell lymphoma (PC-ALCL)

<sup>a</sup>These are meant to be general guidelines. Interpretation of results should be based on individual circumstances and may vary. Not all tests will be required in every case.

USE OF IMMUNOPHENOTYPING IN DIFFERENTIAL DIAGNOSIS OF MATURE B-CELL AND T/NK-CELL NEOPLASMS<sup>a</sup>  
(TO BE USED IN CONJUNCTION WITH CLINICAL PATHOLOGICAL CORRELATION)

T-CELL ANTIGENS-POSITIVE (CD2, CD3, CD5, CD7) [and B-cell antigens-negative (PAX5)]

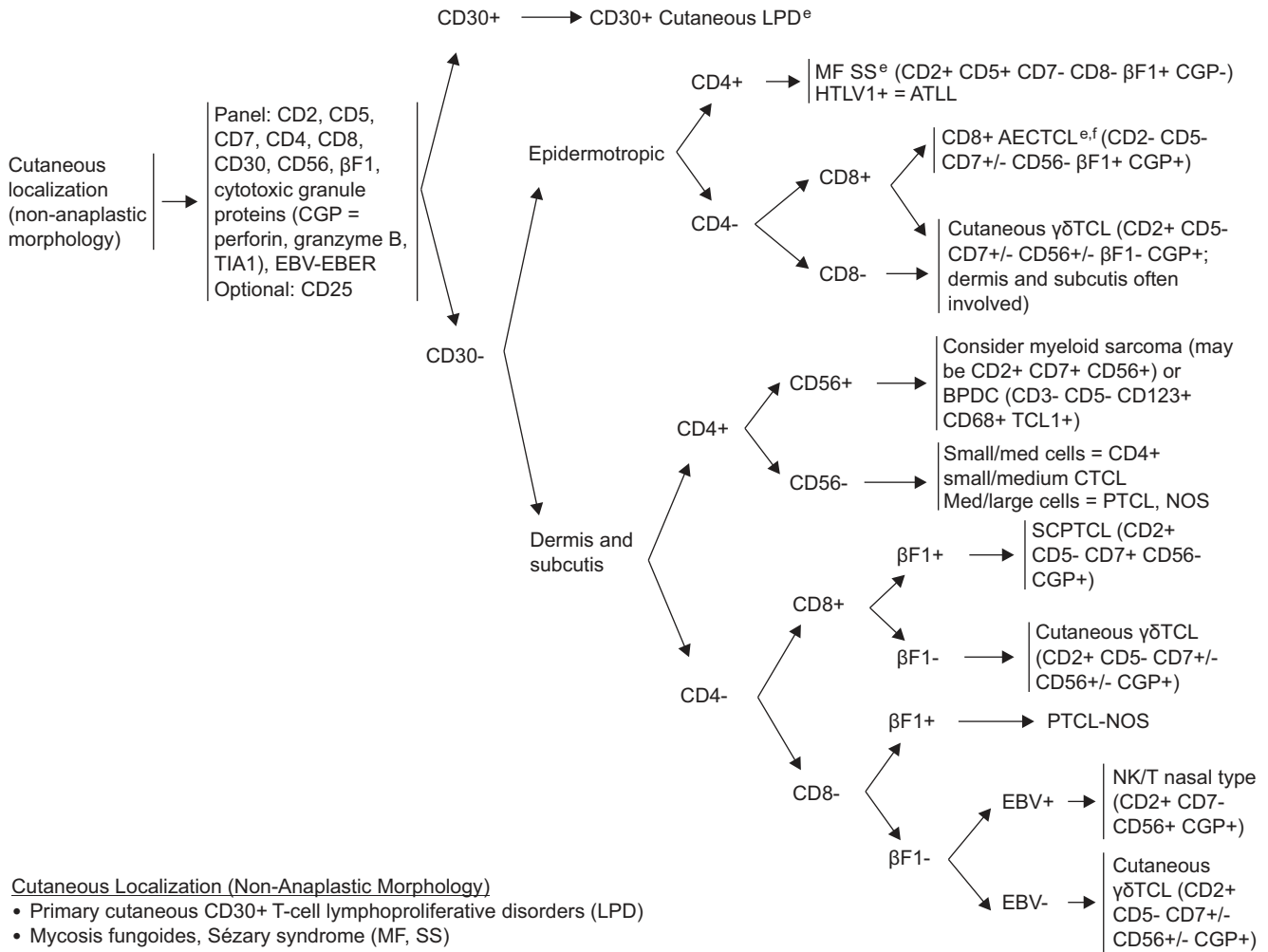

**Cutaneous Localization (Non-Anaplastic Morphology)**

- Primary cutaneous CD30+ T-cell lymphoproliferative disorders (LPD)
- Mycosis fungoides, Sézary syndrome (MF, SS)
- Subcutaneous panniculitis-like T-cell lymphoma (SCPTCL)
- Primary cutaneous gamma-delta T-cell lymphoma (γδTCL)
- Primary cutaneous CD8+ aggressive epidermotropic cytotoxic T-cell lymphoma (AECTCL)
- Primary cutaneous CD4+ small/medium T-cell lymphoma
- Extranodal NK/T-cell lymphoma, nasal type
- Peripheral T-cell lymphoma, NOS
- Blastic plasmacytoid dendritic cell neoplasm (BPDC)

<sup>a</sup>These are meant to be general guidelines. Interpretation of results should be based on individual circumstances and may vary. Not all tests will be required in every case.  
<sup>e</sup>A minority of MF cases can be CD30+, CD4- and either CD8+/-, TIA1+.  
<sup>f</sup>AECTCL has distinctive morphology and clinical presentation.

USE OF IMMUNOPHENOTYPING IN DIFFERENTIAL DIAGNOSIS OF MATURE B-CELL AND T/NK-CELL NEOPLASMS<sup>a</sup>  
(TO BE USED IN CONJUNCTION WITH CLINICAL PATHOLOGICAL CORRELATION)

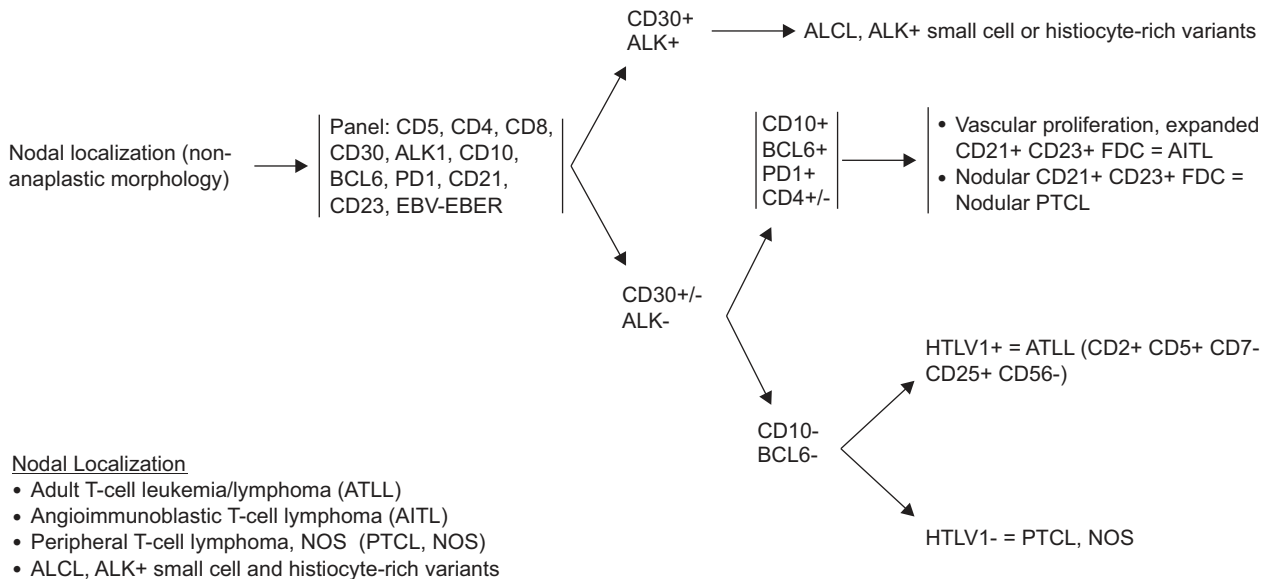
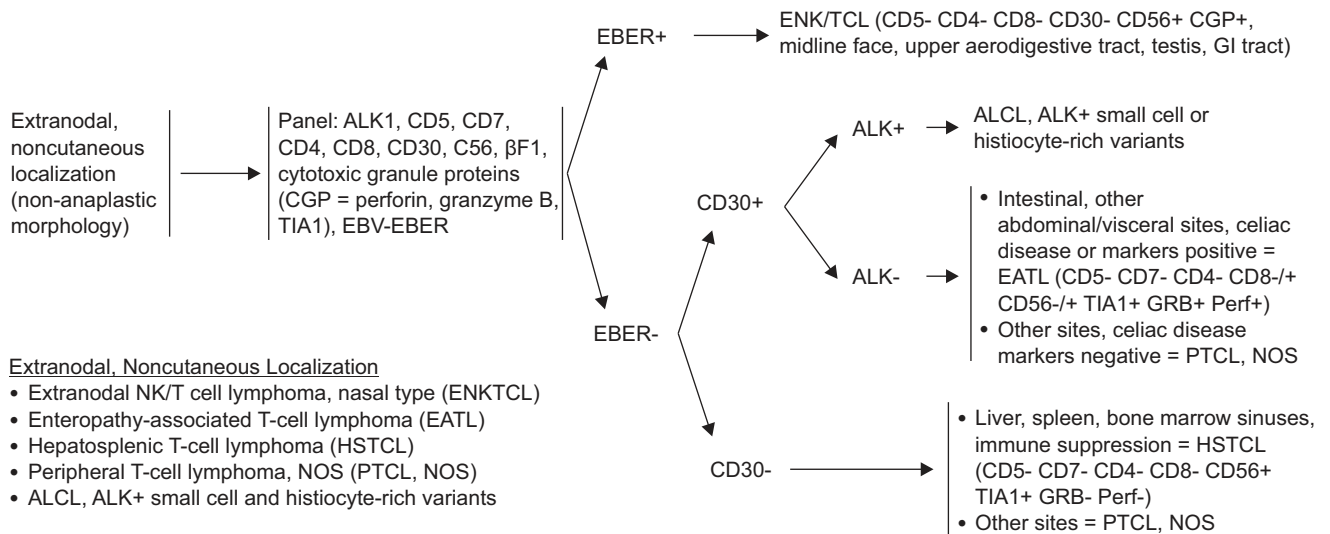

<sup>a</sup>These are meant to be general guidelines. Interpretation of results should be based on individual circumstances and may vary. Not all tests will be required in every case.

## TUMOR LYSIS SYNDROME

The most likely histologies are lymphoblastic lymphoma and Burkitt's lymphoma; however, bulky presentation of DLBCL and patients with CLL and a high white blood cell count may experience tumor lysis syndrome (TLS) at a moderately high frequency.

Laboratory Hallmarks of TLS:

- High potassium
- High uric acid
- High phosphorous
- Low calcium

Symptoms of TLS:

- Nausea and vomiting, shortness of breath, irregular heartbeat, clouding of urine, lethargy, and/or joint discomfort.

Treatment of TLS:

- TLS is best managed if anticipated and treatment started before chemotherapy.
- Centerpiece of treatment includes:
  - ▶ Rigorous hydration
  - ▶ Management of hyperuricemia
  - ▶ Frequent monitoring of electrolytes and aggressive correction is essential
- First-line and at retreatment:
  - ▶ Allopurinol beginning 2-3 days before chemotherapy and continued for 10-14 days
  - or
  - ▶ Rasburicase as indicated (rising uric acid despite allopurinol, high creatinine)
- If TLS is untreated, its progression may cause acute kidney failure, cardiac arrhythmias, seizures, loss of muscle control, and death.

RESPONSE CRITERIA FOR LYMPHOMA  
(not including PET)

Response Category	Physical Examination	Lymph Nodes	Lymph Node Masses	Bone Marrow
CR	Normal	Normal	Normal	Normal
CRu	Normal	Normal	Normal	Indeterminate
	Normal	Normal	> 75% decrease	Normal or indeterminate
PR	Normal	Normal	Normal	Positive
	Normal	≥ 50% decrease	≥ 50% decrease	Irrelevant
	Decrease in liver/spleen	≥ 50% decrease	≥ 50% decrease	Irrelevant
Relapse/ progression	Enlarging liver/spleen, new sites	New or increased	New or increased	Reappearance

Abbreviations: CR, complete response; CRu, complete response unconfirmed; PR, partial response.

Source: From Cheson BD, Horning SJ, Coiffier B, et al. Report of an international workshop to standardize response criteria for non-Hodgkin's lymphoma. *J Clin Oncol* 1999;17:1244. Reprinted with permission from the American Society of Clinical Oncology.

REVISED RESPONSE CRITERIA FOR LYMPHOMA  
(including PET)<sup>a</sup>

Response	Definition	Nodal Masses	Spleen, Liver	Bone Marrow
CR	Disappearance of all evidence of disease	a) FDG-avid or PET-positive before therapy; mass of any size permitted if PET-negative b) Variably FDG-avid or PET-negative; regression to normal size on CT	Not palpable, nodules disappeared	Infiltrate cleared on repeat biopsy; if indeterminate by morphology, immunohistochemistry should be negative
PR	Regression of measurable disease and no new sites	≥ 50% decrease in SPD of up to 6 largest dominant masses; no increase in size of other nodes a) FDG-avid or PET-positive before therapy; ≥ 1 PET-positive at previously involved site b) Variably FDG-avid or PET-negative; regression on CT	≥ 50% decrease in SPD of nodules (for single nodule in greatest transverse diameter); no increase in size of liver or spleen	Irrelevant if positive before therapy; cell type should be specified
SD	Failure to attain CR/PR or PD	a) FDG-avid or PET-positive before therapy; PET-positive at prior sites of disease and no new sites on CT or PET b) Variably FDG-avid or PET-negative; no change in size of previous lesions on CT		
Relapsed disease or PD	Any new lesion or increase by ≥ 50% of previously involved sites from nadir	Appearance of a new lesion(s) > 1.5 cm in any axis, ≥ 50% increase in SPD of more than one node, or ≥ 50% increase in longest diameter of a previously identified node > 1 cm in short axis. Lesions PET-positive if FDG-avid lymphoma or PET-positive before therapy	> 50% increase from nadir in the SPD of any previous lesions	New or recurrent involvement

Abbreviations: CR, complete response; FDG, <sup>18</sup>Fluorodeoxyglucose; PD, progressive disease; PR, partial response; SD, stable disease; SPD, sum of the product of the diameters.

Source: From Cheson BD, Pfistner B, Juweid ME, et al. Revised response criteria for malignant lymphoma. *J Clin Oncol* 2007;25:579–586. Reprinted with permission from the American Society of Clinical Oncology.

<sup>a</sup>Recommended for use with diffuse large B-cell lymphoma and Hodgkin disease/lymphoma.



## RITUXIMAB AND VIRAL REACTIVATION

- Hepatitis B surface antigen (HBsAg) and hepatitis B core antibody (HBcAb) testing for all patients receiving rituxima b
  - ▶ Quantitative hepatitis B viral load by PCR only if one of the screening tests is positive
  - ▶ In areas with high prevalence/population or prevalence is HBV not known, recommend testing all patients receiving immunotherapy, chemotherapy, or chemoimmunotherapy
- Empiric antiviral therapy with oncologic treatment for any patient who is HBsAg or HBcAb positive
  - ▶ Monitor hepatitis B viral load with PCR monthly through treatment and every 3 months thereafter
    - ◊ If viral load is consistently undetectable, treatment is considered prophylactic
    - ◊ If viral load fails to drop, consult hepatologist
  - ▶ Maintain prophylaxis for at least 6 months after oncologic treatment ends
    - ◊ Consult with hepatologist for duration of therapy in patient with active hepatitis B virus

Progressive Multifocal Leukoencephalopathy (PML)

- Caused by the JC virus and is usually fatal
  - ▶ Diagnosis made by PCR of CSF and in some cases brain biopsy
- No known effective treatments
- Check for changes in behavior such as confusion, dizziness or loss of balance, difficulty talking or walking, and vision problems

Note: Patients receiving IV immunoglobulin may be HBcAb+ as a consequence of IVIG therapy.

Text continued from p. 289

standardize the classification of lymphomas.

### IWF Classification

The IWF classified NHL into 3 major categories, low-, intermediate-, and high-grade, based on the morphology and natural history.<sup>8</sup> This classification divided diffuse large B-cell lymphoma (DLBCL) into intermediate- and high-grade groups. However, because this classification did not include immunophenotyping, the categories were not reproducible.<sup>9</sup> In addition, after this classification was published, many new diseases were described that were not included.

### Revised European American Classification

In 1994, the International Lymphoma Study Group developed the Revised European American Lymphoma (REAL) classification, which classified lymphomas based on the cell of origin (B, T, or NK) and included morphology, immunophenotype, and genetic and clinical features for defining diseases.<sup>10</sup> In 1997, the International Lymphoma Classification Project performed a clinical evaluation of the REAL classification in a cohort of 1403 cases of NHL,<sup>11,12</sup> with the diagnosis of NHL confirmed in 1378 (98.2%). This study identified the 13 most common histologic types, comprising approximately 90% of the cases of NHL in the United States. The findings were as follows: DLBCL, 31%; follicular lymphoma (FL), 22%; small lymphocytic lymphoma/chronic lymphocytic leukemia (SLL/CLL), 6%; mantle cell lymphoma (MCL), 6%; peripheral T-cell lymphoma (PTCL), 6%; and mucosa-associated lymphoid tissue (MALT) lymphoma, 5%. The remaining subtypes each occurred in 2% or less of cases. Importantly, in the United States more than 50% of cases of lymphoma are either DLBCL or FL. The study investigators concluded that the REAL classification can be readily applied and identifies clinically distinctive types of NHL.

### WHO Classification

In 2001, the WHO updated the classification of hematopoietic and lymphoid neoplasms<sup>13,14</sup> to apply the principles of REAL classification, representing the first international consensus on classification of hematologic malignancies. The REAL/WHO classification of NHL includes many entities not recognized by the IWF.<sup>13,14</sup> After consideration of cell of origin (B, T, or NK), the classification subdivides lymphomas into those derived from precursor lymphocytes versus those derived from mature lympho-

cytes. The classification is further refined based on immunophenotype, genetic, and clinical features. These considerations have aided in defining active treatment for specific subtypes of lymphoma.

In 2008, the International T-cell Lymphoma Project evaluated the WHO classification of T-cell lymphoma in a cohort of 1314 cases of PTCL and NK/T-cell lymphomas (NKTCLs). The diagnosis of PTCL or NKTCL was confirmed in 1153 cases (88%). The most common subtypes were PTCL-not otherwise specified (NOS; 25.9%), angioimmunoblastic lymphoma (18.5%), NKTCL (10.4%), adult T-cell leukemia/lymphoma (ATLL; 9.6%), anaplastic lymphoma kinase (ALK)-positive anaplastic large cell lymphoma (ALCL; 6.6%), and ALK-ALCL (5.5%).<sup>15</sup> The findings of this study validated the usefulness of the WHO classification for defining subtypes of T-cell lymphomas.

The WHO classification was updated again in September 2008 to add new diseases and subtypes that have been recognized in the past decade, and to better define some of the heterogeneous and ambiguous categories based on recent advances (see the Classification available online, in these guidelines, at [www.NCCN.org](http://www.NCCN.org) [ST-1]).<sup>16,17</sup> Genetic features, detected by cytogenetics or fluorescence in-situ hybridization (FISH) are increasingly important in defining specific NHL subtypes. In addition, detection of viruses, particularly Epstein-Barr virus (human herpesvirus 8 [HHV8] and human T-lymphotropic virus type 1 [HTLV1]), is often necessary to establish a specific diagnosis, particularly in the newer categories of DLBCL.

### 2008 WHO Classification of Mature B-Cell Lymphomas

**CLL/SLL:** The updated classification includes the new definition issued by the International Working Group (IWG) on CLL.<sup>18</sup> In the absence of tissue involvement or disease-related cytopenias, the diagnosis of CLL requires the presence of at least 5000 clonal B lymphocytes per microliter in the peripheral blood for at least 3 months. The presence of fewer than 5000 lymphocytes per microliter in the absence of lymphadenopathy, organomegaly, or other clinical features is defined as monoclonal B lymphocytosis.

**FL:** In FL, pathologic grading according to the number of centroblasts is considered a clinical predictor of outcome. In the 2001 WHO classification, 3 grades were recommended: FL1, FL2, and FL3; FL3

## Non-Hodgkin's Lymphoma

could be optionally stratified into 3A (centrocytes still present) or 3B (sheets of centroblasts). However, grades 1 and 2 do not differ clinically and are now considered one grade (FL1-2) according to the 2008 WHO classification. FL3B is believed to possibly be genetically closer to DLBCL than FL1-3A, and experts have suggested that 3B is more aggressive than 3A. However, this is only true for FL3B with 3q27a abnormalities (BCL6), and FL3B with BCL2 rearrangement is probably similar to FL1-3A.<sup>19</sup>

Hans et al.<sup>20</sup> reported no difference in survival between patients with grade 3A and 3B FL, whereas those with FL3 and more than 50% diffuse components had inferior survival, similar to those with DLBCL. Because FL3B is rare, most studies base the clinical behavior of FL3 mainly on FL3A cases. The 2008 WHO classification mandates stratifying FL3 into either 3A or 3B. FL is thus still divided into 3 grades (FL1-2, FL3A, and FL3B) based on the number of centroblasts. Any diffuse areas in FL should be given a separate diagnosis of DLBCL if it meets the criteria for FL3A or 3B.

Pediatric FL, primary intestinal FL, other extranodal FLs, and intrafollicular neoplasia ("in situ" FL) are the other variants included under FL.

**Pediatric FL:** Children with FL typically have early-stage disease and lack BCL2 expression and t(14;18). Pediatric FL has a better prognosis than adult FL and is often cured with minimal therapy.

**Primary Intestinal FL:** FL of the gastrointestinal tract is a recently described entity common in the small intestine, with most occurring in the duodenum. The morphology, immunophenotype, and genetic features are similar to those of nodal FL. However, most patients have clinically indolent and localized disease. Survival seems to be excellent even without treatment.

**Other Extranodal FL:** In many of the other extranodal sites, the morphology, immunophenotype, and genetic features are similar to those of nodal FL. Patients usually have localized disease, and systemic relapses are rare.

**Intrafollicular Neoplasia or In situ FL:** Intrafollicular neoplasia, or in situ FL, is defined as a morphologically normal lymph node or other lymphoid tissues with a few follicles that are BCL2+. Some of these patients are found to have either a history of FL or FL elsewhere in the body, and some have no evidence of FL.<sup>21</sup> Intrafollicular neoplasia may rep-

resent the nodal equivalent of circulating clonal B cells that have BCL2 rearrangement, but lack the other genetic abnormalities required for the development of a progressive lymphoma. In some cases, this may represent the earliest evidence of a true FL that will progress to an overt lymphoma. A diagnosis of lymphoma should not be made in these cases, and careful staging and follow-up are recommended; patients should not be treated for lymphoma based on this finding.

**Primary Cutaneous Follicle Center Lymphoma:** Primary cutaneous follicle center lymphoma (PCFCL) is a new category in the 2008 classification and is defined as a tumor of neoplastic follicle center cells, including centrocytes and variable numbers of centroblasts, with a follicular, follicular and diffuse, or diffuse growth pattern. PCFCL is the most common B-cell lymphoma of the skin and is classified as a distinct entity in the EORTC classification of cutaneous lymphomas.<sup>22</sup> Gene expression profiling studies have also provided evidence supporting this classification.<sup>23</sup> PCFCL presents as a solitary or localized skin lesion on the scalp, forehead, or trunk. It is characterized by an indolent course and rarely disseminates to extracutaneous sites. PCFCL is consistently BCL6+, and may be CD10+ in cases with a follicular growth pattern. BCL2 is either negative or dim (predominantly seen in cases with a follicular growth pattern).

PCFCL has an excellent prognosis, with a 5-year survival rate of 95%. PCFCL must be distinguished from cutaneous DLBCL presenting on the leg, which is typically IRF4/MUM1+ and strongly BCL2+ and has a more unfavorable prognosis.<sup>24,25</sup>

**DLBCL:** Some of the new categories of DLBCL are defined by extranodal primary sites and the association with viruses such as Epstein Barr virus (EBV) or HHV8. Two borderline categories have also been included for cases that cannot be distinguished between adult Burkitt's lymphoma and DLBCL, and primary mediastinal large B-cell lymphoma (PMBL) and nodular sclerosis classical Hodgkin lymphoma (NSCHL). The ALK+ DLBCL, plasmablastic lymphoma, and primary effusion lymphoma are considered distinct entities. The 2008 classification also has a new category of large B-cell lymphoma arising in HHV8-associated multicentric Castleman's disease.

**DLBCL-NOS:** The 2008 classification has included DLBCL-NOS as a new category to include the germi-

nal center B-cell (GCB) and activated B-cell (ABC) subtypes, and other DLBCL cases that do not belong to any of the 4 specific subtypes (T-cell/histiocytic-rich large B-cell lymphoma, primary central nervous system DLBCL, primary cutaneous DLBCL [PCDLBCL], leg type, or EBV+ DLBCL of the elderly).

Gene expression profiling has been used to identify 3 different subtypes of DLBCL: GCB, ABC, and type 3, which includes PMBL and cases that cannot be classified as GCB or ABC subtype.<sup>26</sup> Gene expression profiling is not yet recommended for routine clinical use. Immunostaining algorithms have been developed to differentiate between the GCB and ABC subtypes using a combination of CD10, BCL6, IRF4/MUM1, GCET1, and FOXP1.<sup>27,28</sup> However, studies based on immunohistochemistry have produced conflicting results regarding the outcome of these subtypes.<sup>29,30</sup>

**PCDLBCL, Leg Type:** PCDLBCL, leg type is an unusual form of DLBCL composed of large transformed B cells most commonly arising on the leg (85%), although they can arise at other sites (15%). These tumors arise from post-GCBs with expression of CD20, IRF4/MUM1, FOXP1, and BCL2; many cases express BCL6 and lack expression of CD10. These tumors can disseminate to non-cutaneous sites, including the central nervous system. Prognosis is poor, particularly when the presentation is with multiple subcutaneous nodules.

**B-Cell Lymphoma, Intermediate Between Burkitt's Lymphoma and DLBCL:** Burkitt's lymphoma is characterized by t(8;14), which results in the juxtaposition of the MYC gene from chromosome 8 with the immunoglobulin heavy chain (IgH) region on chromosome 14 and variant translocations involving MYC and the immunoglobulin light chain genes.<sup>31</sup> Nevertheless, MYC translocations also occur in DLBCL. Recent gene expression profiling studies have confirmed that the distinction between Burkitt's lymphoma and DLBCL is not reliably reproducible with the use of the current criteria of morphology, immunophenotype, and genetic abnormalities.<sup>32,33</sup> Mature aggressive B-cell lymphomas without a molecular Burkitt's lymphoma signature with MYC rearrangements,<sup>33</sup> and those with both t(8;14) and t(14;18) translocations, are associated with a poor prognosis.<sup>34</sup>

This provisional category replaces the "Atypical Burkitt Lymphoma" category that was included in

the 2001 WHO classification. The new category includes lymphomas with features of both DLBCL and Burkitt's lymphoma, but for biologic and clinical reasons should not be diagnosed as DLBCL or Burkitt's lymphoma. Lymphomas in this provisional category include those that are morphologically intermediate between Burkitt's lymphoma and DLBCL, with immunophenotype suggestive of Burkitt's lymphoma (CD10+, BCL6+, BCL2-, and IRF4/MUM1- or weakly positive); those that are morphologically similar to Burkitt's lymphoma but are strongly BCL2+; and those with both MYC and BCL2 rearrangements (double hit) and complex karyotypes.

**B-Cell Lymphoma Intermediate Between PMBL and NSCHL:** PMBL has been recognized as a subtype of DLBCL based on its distinctive clinical and morphologic features.<sup>35</sup> NSCHL is the most common form of Hodgkin lymphoma. Both tumors occur in the mediastinum and affect adolescents and young adults. Gene expression profiling studies strongly support a relationship between PMBL and classical Hodgkin lymphoma (CHL). Approximately a third of the genes that were more highly expressed in PMBL were also characteristically expressed in CHL cells.<sup>36</sup> Traverse-Glehen et al.<sup>37</sup> reported borderline cases with biologic and morphologic features of both CHL and B-cell NHL, known as *mediastinal gray zone lymphomas*.

This provisional category includes lymphomas with overlapping features between CHL and DLBCL, especially PMBL. The cases that morphologically resemble NSCHL have a strong expression of CD20 and other B-cell-associated markers. The cases that resemble PMBL may have dim or no expression of CD20, but strong expression of CD30 and CD15. These lymphomas have a more aggressive course and poorer outcome than either CHL or PMBL.

### 2008 WHO Classification of Mature T-Cell and NK-Cell Lymphomas

The 2008 WHO classification has adapted the EOTRC classification for cutaneous T-cell lymphomas (CTCLs).<sup>22</sup> The new categories include primary cutaneous gamma-delta T-cell lymphoma, primary cutaneous aggressive epidermotropic CD9+ cytotoxic T-cell lymphoma, and primary cutaneous small/medium CD4+ T-cell lymphoma. ALCL, ALK- is now separated from PTCL-NOS as a provisional entity.

**ALCL:** ALCL accounts for fewer than 5% of all cases of NHL. Currently 3 subtypes of ALCL are distinctly

## Non-Hodgkin's Lymphoma

recognized: ALCL, ALK+; ALCL, ALK-; and primary cutaneous ALCL. Primary cutaneous ALCL is a distinct subtype of mature T-cell lymphoma. ALK+ ALCL is most common in children and young adults and characterized by the overexpression of ALK1 protein, resulting from t(2;5) in 40% to 60% of patients.<sup>38,39</sup> Although clinically aggressive, it is highly curable with CHOP (cyclophosphamide, doxorubicin, vincristine, and prednisone) chemotherapy.

The 2001 WHO classification did not require a distinction between ALK+ and ALK- ALCL, but ALK+ ALCL is now clearly known to be a well-defined clinicopathologic entity. Recently, the International Peripheral T-Cell Lymphoma Project reported that patients with ALK+ ALCL had a superior outcome compared with those with ALK- ALCL (5-year failure-free survival, 60% vs. 36%; and 5-year overall survival, 70% vs. 49%, respectively).<sup>40</sup> Contrary to prior reports, ALK- ALCL was associated with a better outcome than PTCL-NOS. The 5-year failure-free survival (36% vs. 20%) and overall survival (49% vs. 32%) were superior compared with PTCL-NOS. Patients with primary cutaneous ALCL had a very favorable 5-year overall survival (90%) despite being negative for ALK1; the 5-year failure-free survival rate was 55%. The findings of this study confirmed that ALK- ALCL should be separated from both ALK+ ALCL and PTCL-NOS.

Based on the recent findings, the 2008 WHO classification included a provisional category for ALK- ALCL. It is morphologically identical to ALK+ ALCL, with a strong and diffuse expression of CD30, no expression of B-cell antigens, and absence of ALK1. The prognosis is intermediate between that of ALK+ ALCL and PTCL-NOS.

### Response Criteria

The IWG published the guidelines for response criteria for lymphoma in 1999. These response criteria are based on the reduction in the size of the enlarged lymph node as measured by CT scan and the extent of bone marrow involvement determined by bone marrow aspirate and biopsy.<sup>41</sup> These guidelines were revised in 2007 by the International Harmonization Project to incorporate immunohistochemistry, flow cytometry, and <sup>18</sup>F-fluorodeoxyglucose (FDG)-PET scans in the definition of response for lymphoma.<sup>42</sup> In the revised guide-

lines, the response category of complete response uncertain was essentially eliminated because residual masses were defined as a partial response or complete response based on the result of a PET scan. Using the revised system, response is categorized as complete response, partial response, stable disease, and relapsed or progressive disease. However, the application of PET to responses is limited to histologies that have a reliable FDG-uptake in active tumor. Response criteria for lymphoma are summarized on pages 310 and 311. However, the revised response criteria have only been validated for DLBCL and HL. The application of the revised response criteria to other histologies requires validation, and the original IWG guidelines should be used.

### Diagnosis

In all cases, the most important first step is to make an accurate pathologic diagnosis. The basic pathologic evaluation is the same in each guideline, although some further evaluation may be useful in certain circumstances to clarify a particular diagnosis; these are outlined in the pathologic evaluation of the individual guideline.

An incisional or excisional lymph node biopsy is recommended to establish the diagnosis of NHL. Core needle biopsy is discouraged unless the clinical situation dictates that this is the only safe means of obtaining diagnostic tissue. Fine needle aspiration (FNA) biopsy is widely used to diagnose malignant neoplasms, but its role in diagnosing lymphoma is still controversial.<sup>43,44</sup> Because the revised REAL/WHO classification is based on both morphology and immunophenotyping, FNA alone is not acceptable as a reliable diagnostic tool for NHL. However, its use in combination with ancillary techniques may provide precise diagnosis, thereby obviating the need for a more invasive biopsy. Recent studies have shown that the diagnostic accuracy of FNA improves significantly when used in combination with immunohistochemistry, flow cytometry, or excisional biopsy.<sup>45-47</sup>

In the NCCN guidelines, FNA results alone are not suitable for making an initial diagnosis of NHL, although they may be sufficient to establish relapse. However, in certain circumstances, when a lymph node is not easily accessible, a combination of core biopsy and FNA in conjunction with appropriate ancillary techniques (polymerase chain reaction [PCR]

for IgH and T-cell receptor gene rearrangements and FISH for major translocations) may be sufficient for diagnosis. This is particularly true for the diagnosis of CLL. In other entities presenting in leukemic phase, such as FL or MCL, a biopsy is still preferred to clarify histological subtype.

Immunophenotypic analysis is essential for differentiating the various subtypes of NHL, proper diagnosis, and deciding treatment for each subtype. It can be performed using flow cytometry and/or immunohistochemistry; the choice depends on the antigens and the expertise and resources available to the hematopathologist. In some cases, flow cytometry and immunohistochemistry are complementary diagnostic tools.<sup>48</sup> Cytogenetic or molecular genetic analysis may be necessary under certain circumstances to identify the specific chromosomal translocations that are characteristic of some NHL subtypes or to establish clonality.

### Immunophenotyping Algorithm

After the publication of the 2008 WHO Classification, the panel developed a series of algorithms for using immunophenotyping to diagnose mature lymphoid neoplasms (see pages 301–308). These algorithms should be used in conjunction with clinical and pathologic correlation. They were developed as a guide for surgical pathologists and to help clinicians interpret pathology reports.

The initial assessment begins with morphologic, clinical, and immunophenotypic analysis. Morphologic assessment involves determining the cell size (small, medium, or large cells), with or without anaplastic morphology. Clinical features include patient's age and the location (nodal, extranodal, and, among extranodal sites, skin vs. other specific sites). The initial immunophenotyping panel should include Pan-B- and Pan-T-cell antigens. Based on the morphologic and clinical features, some of the B- and T-cell subset antigens may also be added in the initial panel.

#### **B-Cell Lymphomas: Expression of One or More B-Cell Antigens (CD20, PAX5, CD79a, CD19, CD22)**

**Small Cells:** In the differential diagnosis of small cell lymphomas (CLL/SLL, MCL, hairy cell leukemia [HCL], splenic marginal zone lymphoma, extranodal marginal zone lymphoma, nodal marginal zone lymphoma, and FL), the panel for immunophenotyping

includes CD5, CD10, CD23, cyclin D1, BCL6, and BCL2, and may include CD25 and CD103 if HCL is suspected (see page 301).

Both CLL and MCL are CD5+ B-cell lymphomas. CLL is usually CD5+, CD23+, and cyclin D1-. However, some cases of CLL have an atypical immunophenotype (CD23-dim or -negative). Dysregulated expression of cyclin D1, a cell cycle protein that results from the chromosomal translocation t(11;14), is seen in most MCL cases.<sup>49,50</sup> This translocation is not seen in other NHLs, although it can be seen in multiple myeloma.

The initial stratification is based on the expression of CD5. If CD5 is positive, confirmatory studies should be performed with CD23 and cyclin D1 to differentiate between CLL and MCL. CD23 is often helpful, but cyclin D1 expression is the most reliable marker for differentiating between CLL and MCL. Thus, immunophenotypic analysis of cyclin D1 or cytogenetic analysis of t(11;14) using FISH is helpful in confirming the diagnosis of MCL.

If CD5 is negative, then the next stratification is based on CD10. CD10 positivity (which must be confirmed by morphology to be on tumor cells and not on residual reactive or colonized follicles) indicates FL, and this diagnosis can be confirmed further by staining for BCL6 and BCL2, and detection of t(14;18) by FISH or PCR, because BCL2 resulting from t(14;18) is overexpressed in 90% of cases of FL.<sup>51</sup> FL is also CD20+, CD5-, and cyclin D1-, and nodular aggregates of CD21+ or CD23+ follicular dendritic cells (FDCs) will usually be found. When CD10 is negative, the differential diagnosis includes marginal zone lymphomas, lymphoplasmacytic lymphomas, and HCL; immunophenotypic analysis of CD103 and CD25 can be used to identify HCL. If both are positive, the suggested diagnosis would be HCL, which can be confirmed by the staining of annexin-1 because HCL is characterized by a strong expression of annexin-1.

CD103- small B-cell neoplasms can be further stratified by staining for cytoplasmic immunoglobulin light chains. If cytoplasmic light chains are negative, the most likely diagnosis is one of the marginal zone lymphomas, which are further classified by a combination of morphologic and clinical features (extranodal, nodal, splenic). If cytoplasmic immunoglobulin is positive, the differential diagnosis includes marginal zone lymphoma or lymphoplas-

## Non-Hodgkin's Lymphoma

macytic lymphoma. This distinction is based on a combination of morphology and clinical features and may be aided by cytogenetics [deletion 7q in splenic marginal zone lymphoma, t(11;18) in some extranodal marginal zone lymphoma, vs. deletion 6q in lymphoplasmacytic lymphoma].

**Medium-Sized Cells:** For medium-sized cell lymphomas (Burkitt's lymphoma; DLBCL; blastoid variant of MCL; B-cell lymphoma; and unclassifiable, intermediate between DLBCL and Burkitt's lymphoma [U-DLBCL/Burkitt's lymphoma]), the immunophenotyping panel includes CD5, CD10, BCL2, BCL6, cyclin D1, and Ki67 (see page 302).

As with small cell lymphomas, the initial stratification is based on CD5. If CD5 is positive, the differential diagnosis is MCL versus DLBCL and it can be confirmed based on the analysis of cyclin D1, BCL6, and IRF4/MUM1. BCL6 rearrangements associated with various chromosomal translocations involving chromosome 3q27 are observed in 28% to 35% of DLBCL.<sup>52</sup> IRF4/MUM1 is a myeloma-associated oncogene activated as a result of chromosomal translocation t(6;14) and is observed in 73% of DLBCLs.<sup>53</sup> Cyclin D1 positivity confirms the diagnosis of blastoid MCL. If cyclin D1 is negative, the diagnosis is confirmed as CD5+ DLBCL, irrespective of the expression of BCL6 and IRF4/MUM1.

If CD5 is negative, the stratification is based on the expression of CD10. If CD10 is positive, the differential diagnosis includes Burkitt's lymphoma versus U-DLBCL/Burkitt's lymphoma. These can be further stratified based on Ki67, BCL2, and BCL6 expression. BCL6+, BCL2-, and Ki67 ( $\geq 95\%$ ) would support the diagnosis of Burkitt's lymphoma, especially in pediatric cases. In adults, when Burkitt's lymphoma is suspected, FISH for MYC, BCL2, and possibly BCL6 should be performed to confirm the presence of MYC rearrangement and assess for the presence of a dual rearrangement of MYC and BCL2 (double hit), particularly if BCL2 is expressed.<sup>51</sup> If MYC is positive and BCL2 and BCL6 are not rearranged, Burkitt's lymphoma may be diagnosed. If BCL2 or BCL6 is rearranged, with or without MYC, the diagnosis could be U-DLBCL/Burkitt's lymphoma.

CD10- medium-sized B-cell neoplasms generally fall into the category of U-DLBCL/Burkitt's lymphoma. If both BCL2 and BCL6 are positive according to immunohistochemistry, FISH for MYC, BCL2, and BCL6 should be performed to check for

double hit U-DLBCL/Burkitt's lymphoma, which has a poor prognosis.

**Large Cells:** DLBCL-NOS, the newly described subtypes of DLBCL, and the pleomorphic variant of MCL are characterized by large cells. The immunophenotyping panel for large cell lymphomas includes CD5, CD10, BCL6, and IRF4/MUM1 (pages 303 and 304). The first stratification is based on the expression of CD5. If CD5 is positive, cyclin D1 expression should be assessed to distinguish between pleomorphic MCL and CD5+ DLBCL-NOS, which has a variable expression of BCL6 and MUM1. If CD5 is negative, the differential diagnosis is DLBCL which can be stratified again based on the expression of CD10. CD10 positivity confirms the diagnosis of DLBCL-NOS (GCB subtype). If CD10 is negative, confirmatory studies can be performed with BCL6 and IRF4/MUM1 to differentiate GCB subtype (BCL6+ and IRF4/MUM1-) from non-GCB subtypes.

For clinical purposes, distinguishing between GCB and non-GCB subtypes is not necessary; however, the recently described DLBCL subtypes (EBV+ DLBCL of the elderly, DLBCL associated with chronic inflammation, ALK+ DLBCL, plasmablastic lymphoma) are often non-GCB types, and this immunophenotype may prompt further analysis to detect these subtypes.

Additional markers (CD20, PAX5, CD30, ALK1, CD138, and cytoplasmic immunoglobulin, and detection of HHV8 and EBV) may be useful for the further classification of large B-cell lymphomas. In a tumor positive for both CD20 and PAX5, CD30 positivity supports the diagnosis of PMBL. If CD30 is positive and the morphology overlaps with classical HL, determining CD15 expression may be helpful: if it is positive, this supports either U-DLBCL/CHL or CHL, depending on the morphologic features. Absence of CD15 would support PMBL. Absence of both CD20 and PAX5 and expression of MUM1 and CD138 suggest terminal B-cell differentiation, and the differential diagnosis would include ALK+ DLBCL, plasmablastic lymphoma, and primary effusion lymphoma.

ALK+ DLBCL is characterized by the expression of ALK protein and absence of CD30. It has an aggressive clinical course and poor outcome.<sup>54</sup> If ALK is negative, the stratification is now based on the staining for EBV and HHV. EBV+ and HHV8- indicate plasmablastic lymphoma. Primary

effusion lymphoma is HHV8+ with or without EBV and is CD30+. DLBCL associated with HHV8+ multicentric Castleman's disease is CD20+/- and HHV8+, and has characteristic morphologic features. Many of these DBLCL subtypes have plasmacytic differentiation and will have detectable cytoplasmic immunoglobulin.

**Cutaneous B-Cell Lymphomas:** In the WHO classification, 3 main types of primary cutaneous B-cell lymphomas are recognized: PCFCL; PCDLBCL, leg type; and primary cutaneous marginal zone lymphoma (PCMZL). PCMZLs express CD20 and BCL2 but are negative for CD5, CD10, and BCL6.<sup>55</sup> PCFCL, which is an indolent disease, has a germinal center phenotype, whereas most PCDLBCLs, leg type, which are aggressive tumors, have an activated B-cell phenotype.<sup>23</sup>

The immunophenotyping panel includes CD10, BCL2, BCL6, IRF4/MUM1, and FDC markers (CD21 or CD23) to detect neoplastic follicles or colonized germinal centers. Initial stratification is based on CD10. CD10 positivity on the neoplastic cells indicates PCFCL; however, many cases of PCFCL are CD10-. If CD10 is negative, the differential diagnosis is based on the expression of BCL2. BCL2 is usually negative in PCFCL but strongly expressed in PCDLBCL. When BCL2 is negative, immunophenotypic analysis of BCL6 and IRF4/MUM1 is necessary to distinguish between PCFCL and PCMZL. PCFCL is consistently BCL6+ and IRF4/MUM1-, whereas PCMZL is BCL6- and IRF4/MUM1 can be either positive or negative. If BCL2 is positive, IRF4/MUM1 is helpful to differentiate between PCFCL and PCDLBCL, leg type, because PCFCL is usually IRF4/MUM1-, whereas PCDLBCL, leg type is usually IRF4/MUM1+.

#### **T-Cell Lymphomas: Expression of One or More Pan-T Antigens (CD2, CD3, CD5, CD7, CD43, CD45RO)**

**T-Cell Lymphomas (Anaplastic Morphology):** In lymphomas with anaplastic morphology, the immunophenotyping panel includes CD30, CD15, PAX5, ALK, and EBV-EBER. ALCL has a strong, diffuse expression of CD30. If CD30 is positive, evaluation of ALK1 status is used to identify ALK+ ALCL. If ALK1 is negative, analysis of CD15 and PAX5 are essential in the differential diagnosis of non-cutaneous ALK- ALCL and classical HL. ALK- ALCL is PAX5-, whereas CHL typically shows expression of CD15 and dim expression of PAX5.

**CTCLs (Non-Anaplastic Morphology):** Mycosis fungoides and Sézary syndrome are the most common types of CTCLs lacking anaplastic morphology. Primary CTCLs are very rare. In the WHO classification, 3 rare provisional entities are included under primary CTCL: primary cutaneous gamma-delta T-cell lymphoma, primary cutaneous CD8+ aggressive epidermotropic cytotoxic T-cell lymphoma (AECTCL), and primary cutaneous CD4+ small/medium T-cell lymphoma.

The immunophenotyping panel for the diagnosis of CTCLs includes CD2, CD5, CD7, CD4, CD8, CD30, CD56,  $\beta$ F1, and cytotoxic granule proteins. Initial stratification can be based on CD30. Strong and uniform CD30 positivity favors primary cutaneous CD30+ T-cell lymphoproliferative disorders, even if the morphology is not obviously anaplastic; however, some CD30+ cells can be seen in mycosis fungoides and ATLL. In an epidermotropic CTCL, if CD30 is negative, then the differential diagnosis is based on CD4 and CD8 expression. If CD4 is positive, then the differential diagnosis is mycosis fungoides/Sézary syndrome versus ATLL. ATLL and mycosis fungoides/Sézary syndrome both lack cytotoxic granule proteins. ATLL is CD25+, whereas mycosis fungoides/Sézary syndrome is CD25-; it is suggested by epidemiologic factors and can be confirmed through serologic testing for HTLV1. If CD4 is negative and CD8 is positive, then the diagnosis is more likely AECTCL, which has an aggressive clinical course.<sup>56</sup> Because a minority of mycosis fungoides cases can be CD30+, CD4-, and CD8+/-, AECTCL should be confirmed further by its characteristic immunophenotype (CD4-, CD3+, CD8+, CD5-, and CD45RO-). Cutaneous gamma-delta T-cell lymphoma may be epidermotropic, but typically also involves dermis and subcutis; it is typically CD4-, CD8-, CD5-, and CD56+, but may express CD8. Staining for  $\beta$ F1 is negative, and cytotoxic granule proteins are strongly expressed. Subcutaneous panniculitis-like T-cell lymphoma is typically CD3+, CD7+, CD8+, and  $\beta$ F1+, and expresses cytotoxic granule proteins.

**Nodal Localization (Non-Anaplastic Morphology):** Angioimmunoblastic T-cell lymphoma (AITL), ATLL, PTCL-NOS, and small cell variants of ALCL are included in this category. The immunophenotypic panel includes CD5, CD4, CD8, CD30, ALK1, CD10, BCL6, PD1, CD21, CD23, and EBV-EBER. Follicular helper T-cell markers CD10, BCL6, PD1,



## Non-Hodgkin's Lymphoma

and CD4 are helpful in differentiating among AITL, PTCL-NOS, and ATLL. The initial stratification is based on ALK and CD30 expression. If CD30 and ALK are negative and CD10, BCL6, PD1, and CD4 are positive, the likely diagnosis is AITL; this can be confirmed by detection of FDCs expressing CD21 and CD23, and typically some EBV+ large B cells. If follicular helper T-cell markers are absent, the differential diagnosis includes ATLL and PTCL-NOS; expression of CD25, clinical features, and assessment for HTLV1 antibodies can confirm the diagnosis of ATLL.

**Extranodal Non-Cutaneous Localization (Non-Anaplastic Morphology):** Extranodal NK T-cell lymphoma, nasal type (ENKTCL); enteropathy-associated T-cell lymphoma (EATL); hepatosplenic T-cell lymphoma (HSTCL); extranodal involvement by PTCL-NOS; and ALCL, and ALK+ small-cell and histiocyte-rich variants are included in this category. The differential diagnosis will be affected by the specific clinical presentation. Initial stratification may be based on the EBV-EBER status. If EBER is positive, ENKTCL is suggested and can be confirmed by CD56 expression. If EBER is negative, the differential diagnosis may include EATL; HSTCL; ALCL, ALK+ small-cell or histiocyte-rich variants; and extranodal PTCL-NOS, depending on the clinical features. The stratification can then be based on the expression of CD30 and ALK1. If ALK is negative, expression of  $\beta$ F1, CD4, CD5, CD8, and CD30 may be useful in further classification: EATL is  $\beta$ F1+, CD30+, and CD56-/+ , whereas HSTCL is usually  $\beta$ F1-, CD30-, and CD56+.

## Workup

Essential workup includes a complete physical examination, with particular attention to node-bearing areas; determination of the size of liver and spleen, symptoms present, and performance status; and laboratory studies, including CBC, serum lactate dehydrogenase (LDH), hepatitis B testing (see later discussion), comprehensive metabolic panel, and CT chest/abdominal/pelvic with oral and intravenous contrast (unless coexistent renal insufficiency). Multiple-gated acquisition (MUGA) scan or echocardiograms are recommended when anthracyclines and anthracenedione-containing regimens are used. Bone marrow biopsy with or without aspirate is essential whenever treatment is considered; however,

it may be deferred in certain circumstances (see later discussion).

Because of the risk for hepatitis B reactivation, the panel has included hepatitis B testing (hepatitis B surface antigen and core antibody) as part of essential workup before initiating treatment in all patients who will receive rituximab. Furthermore, hepatitis B reactivation has been reported with chemotherapy alone, and testing should be considered in anyone with a risk factor (e.g., blood transfusion, intravenous drug abuse) or if from a region with a non-negligible prevalence of hepatitis B infection. For further discussion, see Rituximab and Viral Reactivation on page 312. Hepatitis C testing is needed only in high-risk patients.

Optional procedures (depending on specific lymphoma type) include  $\beta_2$ -microglobulin, CT or PET-CT scans, endoscopic ultrasound (gastric MALT lymphoma), head CT or brain MRI, and lumbar puncture to analyze cerebrospinal fluid (MCL and DLBCL). Discussion of fertility issues and sperm banking should be addressed in the appropriate circumstances.<sup>57</sup>

Bone marrow biopsy is usually included in the workup for all patients with NHL. Bone marrow involvement occurs in 39% of low-grade, 36% of intermediate-grade, and 18% of high-grade lymphomas. Bone marrow involvement was associated with significantly shorter survivals in patients with intermediate- or high-grade lymphomas.<sup>58</sup> In a recent retrospective analysis, the incidence of and parameters predicting bone marrow involvement were analyzed in 192 patients with stage I and II DLBCL. Overall incidence of bone marrow involvement was 3.6%. The authors concluded that bone marrow biopsy may be safely omitted in selected patients with early-stage DLBCL.<sup>59</sup>

The effect of bone marrow biopsy on the management of patients or on the prognosis of lymphoma has not been proven in prospective clinical trials. In cutaneous B-cell lymphomas, bone marrow biopsy is essential for PCDLBCL, leg type because it is an aggressive lymphoma that will probably require systemic treatment, whereas its role in PCFCL and PCMZL is less clear. Recent studies have indicated that bone marrow biopsy is an essential component of staging in patients with PCFCL first presenting in the skin, whereas it appears to have limited value in patients with marginal zone lymphoma presenting in the skin,

and may be considered only in selected cases.<sup>60,61</sup>

These guidelines include bone marrow biopsy with or without aspirate as part of essential workup for all lymphomas. However, in patients with low-bulk indolent disease with radiographic clinical stage III disease, an initial staging bone marrow evaluation can be deferred if observation is recommended because it will not change the clinical recommendations, but it is essential for evaluating potentially early-stage indolent lymphomas (clinical stage I or II). Some panel members advocate bilateral core biopsies in this situation.<sup>62</sup> Bilateral cores are recommended if radioimmunotherapy is considered.

FDG-PET scan has been used for initial staging, restaging, and follow-up of patients with NHL.<sup>63</sup> In a recent meta-analysis, PET showed a high positivity and specificity when used for the staging and restaging of patients with lymphoma.<sup>64</sup> However, PET scans can be misleading because other organs in addition to the malignant tumors can take up radioactive FDG. Lesions smaller than 1 cm are not reliably visualized with PET scans. PET scan is currently not used routinely for staging in lymphoma. Although PET scans may detect additional disease sites, the clinical stage is only modified in 15% to 20% of patients; the additional information provided by PET scans results in a change in treatment in only 8% of patients. PET scan has generally been used in conjunction with diagnostic CT scans.

Integrated PET-CT has largely replaced the dedicated CT scan in the United States. This diagnostic study has distinct advantages in both staging and restaging compared with full-dose diagnostic CT or PET alone.<sup>65,66</sup> In a retrospective study, PET-CT performed with low-dose non-enhanced CT was found to be more sensitive and specific than routine contrast-enhanced CT in evaluating lymph node and organ involvement in patients with Hodgkin disease or high-grade NHL.<sup>66</sup> Preliminary results of another recent prospective study (N = 47 patients; those who had undergone prior diagnostic CT were excluded) showed a good correlation between low-dose unenhanced and full-dose enhanced PET-CT in evaluating lymph nodes and extranodal disease in lymphomas.<sup>65</sup> However, the lack of intravenous contrast and diminished resolution can make it difficult in some cases to interpret the anatomic localization and significance of FDG-avid sites. Further studies are needed to determine the role of PET-CT scans

in the initial staging of lymphomas. The panel has included PET-CT scan as an optional workup procedure for selected patients.

## Supportive Care

### Viral Reactivation

**Hepatitis B Virus Reactivation:** Hepatitis B virus reactivation has been reported to occur in patients treated with chemotherapy with or without rituximab. Treatment with rituximab alone is also a risk for hepatitis B reactivation.<sup>67</sup> Reactivation may result in a fulminant hepatitis, hepatic failure, and death. The median time to diagnosis of hepatitis was approximately 4 months after the initiation of rituximab, according to the package insert.

Testing of patients at risk for hepatitis B reactivation should include hepatitis B surface antigen (HBsAg) and hepatitis B core antibody (HBcAb). In patients for whom one or both of these tests is positive, a baseline hepatitis B viral load should be determined with quantitative PCR. However, a negative baseline PCR does not preclude the possibility of activation. Patients positive for HBsAg are at a greater risk for hepatitis B reactivation than those positive for HBcAb.<sup>67</sup> In a prospective study of 100 Chinese patients undergoing chemotherapy for lymphoma, hepatitis developed in 67% of those who were HBsAg+ and 14% of those who were HBsAg- during cytotoxic therapy.<sup>68</sup> A retrospective study of Italian patients with lymphoma who were HBcAb+ found that 2.7% of patients treated with rituximab and chemotherapy developed viral reactivation compared with 0.8% of those treated with chemotherapy alone. Hepatitis was not seen in patients who were observed or underwent other therapy (radiation, antibiotics, interferon).<sup>69</sup> Other risk factors for reactivation include young age, male gender, elevated pretreatment viral load, and prolonged immunosuppression.<sup>70</sup>

Antiviral prophylaxis has been effective in preventing hepatitis B reactivation during chemoimmunotherapy in patients who are HBsAg+.<sup>71-73</sup> The results of a systematic review of 14 studies showed that lamivudine prophylaxis reduced the risk for HBV reactivation by 79% or greater in patients who were HBsAg+ undergoing chemotherapy. Hepatitis B-associated hepatic failure and death may also be reduced.<sup>71</sup> None of the patients in the preventive lamivudine group developed HBV-

## Non-Hodgkin's Lymphoma

related hepatic failure compared with 21 of 162 patients in the control group, and only 4 deaths were attributable to hepatitis B in the preventive lamivudine group compared with 27 deaths in the control group. Lamivudine was well tolerated with no adverse effects.

In a small study randomizing 30 HBsAg+ patients with lymphoma to receive lamivudine either before chemotherapy or for the treatment of increased viral load based on hepatitis B DNA PCR levels, Lau et al.<sup>74</sup> showed that preemptive antiviral treatment with lamivudine was superior to deferred treatment. This study of HBV reactivation was observed in 53% of monitored patients and none in the prophylaxis group. Interestingly, clinical cancer-related outcomes were also significantly better in the prophylaxis group than the treatment group.

The NCCN guidelines recommend HBsAg and HBcAb testing for all patients receiving rituximab. In patients from areas with high hepatitis B prevalence (Asia, Africa, Eastern Europe, and portions of South America) or in which prevalence is not known, all patients undergoing immunotherapy, chemotherapy, or chemoimmunotherapy should be tested for HBsAg and HBcAb (page 312). Empiric antiviral therapy with oncologic treatment is recommended for any patient who is either HBsAg+ or HBcAb+ and will receive rituximab-containing therapy. Patients undergoing chemotherapy alone should receive prophylaxis if they have a measurable viral load independent of the viral serology. If patients have no measurable virus according to PCR, prophylaxis should be given to those who are HBsAg+ and may be considered in those who are HBcAb+.

The optimal duration of prophylaxis remains undefined, but the panel recommended it be maintained for at least 6 months after the completion of oncologic treatment. During the treatment period, viral load should be monitored monthly with PCR and 3 months thereafter. If viral load is consistently undetectable, treatment is considered prophylactic. If viral load fails to drop, consultation with a hepatologist is recommended. Several appropriate agents are available for viral prophylaxis; good choice will be driven by institutional standard or recommendation from the consultant.

**Progressive Multifocal Leukoencephalopathy:** Progressive multifocal leukoencephalopathy (PML) is a serious and usually fatal central nervous system

infection caused by JC polyoma virus. In a recent report of 57 cases from the Research on Adverse Drug Events and Reports project, 52 patients with lymphoproliferative disorders developed PML after treatment with rituximab and other treatments that included hematopoietic stem cell transplantation, or chemotherapy with purine analogs or alkylating agents.<sup>75</sup> Median time from last rituximab dose to PML diagnosis was 5.5 months. Median time to death after PML diagnosis was 2.0 months. The case-fatality rate was 90%.

PML is usually diagnosed through PCR of cerebrospinal fluid or sometimes brain biopsy. No effective treatment exists for PML. Patients must be monitored carefully for the development of any neurologic symptoms (page 312). Currently no pretreatment evaluation can be undertaken to predict the subsequent development of PML.

**Cytomegalovirus Reactivation:** Cytomegalovirus reactivation is a well-documented side effect in patients receiving alemtuzumab. Monitoring patients for cytomegalovirus reactivation regularly with PCR is effective in managing cytomegalovirus reactivation.<sup>76</sup> Cytomegalovirus reactivation is associated with relatively mild or no symptoms when prophylactic measures are used during treatment with alemtuzumab.

These guidelines recommend cytomegalovirus viremia monitoring (every 1–2 weeks) and antiviral prophylaxis (valganciclovir during treatment and for 2 months after the completion of treatment) for patients during treatment with alemtuzumab.

### Autoimmune Cytopenias

Autoimmune hemolytic anemia (AIHA), immune-mediated thrombocytopenia, also known as immune thrombocytopenic purpura (ITP), and pure red blood cell aplasia are well documented in patients with CLL.<sup>77</sup>

The incidence of AIHA is related to stage, disease progression, and IgV<sub>H</sub> mutational status. Treatment-related AIHA (after treatment with fludarabine) may be severe. Fludarabine therapy should be discontinued and subsequent use of the agent should be avoided in these cases. AIHA can be managed with corticosteroids in most cases; however, intravenous immune globulin (IVIg), immunosuppression, and splenectomy have been used in steroid refractory cases. Case reports and retrospective analyses have indicated favorable responses to rituximab in patients with refractory AIHA.<sup>78</sup>

First-line therapy with steroids is recommended for ITP. Similarly, IVIg, cyclosporin, splenectomy, and rituximab can be effective in treating steroid-refractory ITP.<sup>79,80</sup> More recently, synthetic thrombopoietin-like agents such as romiplostim and eltrombopag have shown promising results in the treatment of thrombocytopenia associated with ITP.<sup>81-84</sup> In 2008, both romiplostim and eltrombopag received FDA approval for the treatment of thrombocytopenia in patients with ITP refractory to steroids, IVIg, and splenectomy.

Pure red blood cell aplasia can complicate the management of lymphoproliferative disorders, including CLL. Management strategies include the need to treat the underlying disorder. Corticosteroids tend to be less effective in treating pure red blood cell aplasia than ITP or AIHA. If corticosteroids are not effective, cytotoxic or immunosuppressive therapy can be used, including cyclophosphamide, 6-mercaptopurine, azathioprine, and cyclosporin. Alemtuzumab has been reported to be active in steroid-refractory cases.<sup>85</sup> In the very refractory cases, allogeneic stem cell transplantation may be necessary.

### Tumor Lysis Syndrome

Tumor lysis syndrome (TLS) is characterized by metabolic abnormalities caused by the abrupt release of intracellular contents into the blood resulting from cellular disintegration induced by chemotherapy. It is usually observed within 12 to 72 hours after the start of chemotherapy.<sup>86</sup> Unchecked TLS can induce profound metabolic changes resulting in cardiac arrhythmias, acute renal failure, and death.

The risk factors for TLS include bulky tumors that are chemosensitive, rapidly proliferative or aggressive hematologic malignancies, an elevated leukocyte count, and an elevated pretreatment LDH level. The most likely histologies are lymphoblastic lymphoma and Burkitt's lymphoma. However, bulky presentation of DLBCL and patients with CLL and a high white blood cell count may experience TLS at a moderately high frequency.

Cairo and Bishop<sup>87</sup> recently classified TLS into laboratory and clinical types. Laboratory TLS is defined as a 25% increase in the levels of serum uric acid, potassium, or phosphorus or a 25% decrease in calcium levels. Clinical TLS refers to laboratory TLS with clinical toxicity that requires intervention. Clinical complications may include renal insufficiency, cardiac arrhythmia, or seizures. The

4 primary electrolyte abnormalities of TLS are hyperkalemia, hyperuricemia, hyperphosphatemia, and hypocalcemia. Symptoms associated with TLS may include nausea and vomiting, diarrhea, seizures, shortness of breath, and irregular heartbeat.

TLS is best managed if anticipated and treatment started before chemotherapy. The cornerstone for the management of TLS is hydration. It is also essential to control hyperuricemia. Allopurinol should be administered before the initiation of chemotherapy, wherein patients whose uric acid level remains elevated despite treatment with allopurinol or who have renal insufficiency, treatment with rasburicase is indicated. Electrolytes and renal function should be monitored every 6 to 8 hours, with appropriate interventions for hyperkalemia and hyperphosphatemia. Careful clinical monitoring will help to preempt complications, and in many cases admission to the intensive care unit is appropriate. Cardiac monitoring or serial electrocardiogram may be beneficial to identify early electrolyte-related cardiac abnormalities.

Allopurinol is a xanthine analog and a competitive inhibitor of xanthine oxidase, thereby blocking conversion of purine metabolites to uric acid. Allopurinol will decrease the formation of uric acid production and has been shown to reduce the incidence of uric acid uropathy.<sup>88</sup> Because it inhibits new uric acid formation rather than reduces existing uric acid, elevated levels of uric acid can take several days to normalize after initiation of treatment, thereby delaying the start of chemotherapy. Furthermore, allopurinol may lead to the accumulation of xanthine crystals in renal tubules, leading to acute obstructive uropathy. It is also associated with reduced clearance of 6-mercaptopurine and high-dose methotrexate.

Rasburicase is a recombinant urate oxidase that catalyzes the oxidation of uric acid to a highly soluble nontoxic metabolite that is easily excreted. It has been shown to be safe and highly effective in preventing and treating chemotherapy-induced hyperuricemia in children and adults.<sup>89</sup> The GRAAL1 (Groupe d'Etude des Lymphomes de l'Adulte Trial on Rasburicase Activity in Adult Lymphoma) study evaluated the efficacy and safety of rasburicase for preventing and treating hyperuricemia in patients with NHL during induction chemotherapy.<sup>90</sup> Uric acid levels decreased within 4 hours after the first injection of the drug. Creatinine levels and other

## Non-Hodgkin's Lymphoma

metabolites were also controlled with the administration of rasburicase.

Cortes et al.<sup>91</sup> recently reported the results of a prospective, randomized controlled trial comparing the efficacy of rasburicase and allopurinol in adult patients with hematologic malignancies at high or potential risk for TLS. The normalization of serum uric acid levels ( $\leq 7.5$  mg/dL) at 3 to 7 days was 87% in the rasburicase arm, 78.3% in the rasburicase plus allopurinol arm, and 65.9% in the allopurinol arm. Rasburicase was superior to allopurinol in the overall study population, in patients at high-risk for TLS (89.0% vs. 62.8%), and in those with baseline hyperuricemia (89.5% vs. 52.9%). The time to control serum uric acid in hyperuricemic patients was 4.1 and 27 hours in the rasburicase and allopurinol arms, respectively. However, rasburicase can induce anaphylactic reactions and the development of antibodies. Other adverse reactions include methemoglobinemia and severe hemolysis in patients with glucose-6-phosphate dehydrogenase (G6PD) deficiency.

The NCCN guidelines recommend that allopurinol should be started 2 to 3 days before chemotherapy and continued for 10 to 14 days. When uric acid levels rise despite the use of allopurinol, patients can be switched to rasburicase (page 309).

## Burkitt's Lymphoma

### Overview

Burkitt's lymphoma is a rare and aggressive B-cell tumor typically involving extranodal disease sites. The WHO classification describes 3 clinical variants of Burkitt's lymphoma: endemic, sporadic, and immunodeficiency-associated Burkitt's lymphoma. The endemic variant is the most common form of Burkitt's lymphoma that occurs in African children, and nearly all cases are associated with EBV infection. Sporadic Burkitt's lymphoma accounts for 1% to 2% of all adult lymphomas in the United States and Western Europe.<sup>92,93</sup> Immunodeficiency-associated Burkitt's lymphoma occurs mainly in patients infected with HIV, in some posttransplant patients, and in individuals with congenital immunodeficiency.

### Diagnosis

The typical immunophenotype of Burkitt's lymphoma is sIg+, CD10+, CD19+, CD 20+, CD22+, TdT, Ki67+ (100%), BCL2-, and BCL6+. Most cases

(80%) of classical Burkitt's lymphoma are characterized by t(8;14), which causes the juxtaposition of MYC gene from chromosome 8 with the IgH region on chromosome 14.<sup>31</sup> Other variants, such as t(8;22) or t(2;8), are less common. Some cases of DLBCL are also associated with an overexpression of MYC. Therefore, diagnosing Burkitt's lymphoma can be challenging using routine cytogenetic analysis. FISH using a break-apart probe or long-segment PCR is more reliable for detecting t(8;14) and its variants.<sup>94</sup> Recent studies by Dave et al.<sup>32</sup> and Hummel et al.<sup>33</sup> reported gene expression profiling as an accurate, quantitative method for distinguishing Burkitt's lymphoma from DLBCL. However, this technique is not yet recommended for widespread clinical use.

The 2008 WHO lymphoma classification eliminates atypical Burkitt's lymphoma. For cases without typical morphology or immunophenotype, a provisional category has been introduced, B-cell lymphoma, unclassifiable, with features intermediate between DLBCL and Burkitt's lymphoma.<sup>16</sup> This group also includes cases that harbor MYC and BCL2 translocations, the so-called "double-hit" lymphomas.

### Workup

The initial diagnostic workup for Burkitt's lymphoma includes a detailed physical examination (with special attention to node-bearing areas, liver, and spleen) and CT scans of the chest, abdomen, and pelvis (page 290). PET or integrated PET-CT scans are not recommended for routine use, because findings of PET or PET-CT would probably not alter therapy for patients with newly diagnosed Burkitt's lymphoma. If the treatment includes an anthracycline-containing regimen, cardiac evaluation with MUGA scan or echocardiogram is recommended. Bone marrow aspiration, biopsy, and lumbar puncture are essential. In these highly aggressive lymphomas, as in DLBCLs, the serum LDH level has prognostic significance. These tumors exhibit a high degree of cellular proliferation, as determined by Ki-67 staging, and frequent 8q translocations. Because Burkitt's lymphoma is frequently associated with HIV infection, HIV serology should be part of the diagnostic workup for these diseases.

### Treatment

Burkitt's lymphoma is curable in a significant subset of patients when treated with dose-intensive, multiagent chemotherapy regimens, including central

## Non-Hodgkin's Lymphoma

nervous system prophylaxis. Approximately 60% to 90% of pediatric and young adult patients with Burkitt's lymphoma experience durable remission if treated appropriately. However, the outcome of older adults with Burkitt's lymphoma seems to be less favorable, but patients older than 40 are significantly underrepresented in the published clinical trials.<sup>95</sup> It is preferred that patients with Burkitt's be treated at centers with expertise in the management of the disease.

Most regimens used in adult patients were developed from the pediatric protocols. TLS is more common in patients with Burkitt's lymphoma and should be managed as outlined in the section on Tumor Lysis Syndrome (page 323).

CODOX-M (cyclophosphamide, vincristine, doxorubicin, high-dose methotrexate), alternating with IVAC (ifosfamide, etoposide, and high-dose cytarabine), is a highly effective regimen developed by Magrath et al.<sup>96</sup> Both cycles included intrathecal chemotherapy (cytarabine or methotrexate). In 1998, Adde et al.<sup>97</sup> reported the updated results obtained with 4 cycles of CODOX-M/IVAC protocol given to 66 previously untreated patients (55 Burkitt's or Burkitt's-like lymphoma and 11 had DLBCL). The 1-year event-free survival rate was 85% and the median follow-up was 48 months.

In an international phase II study, Mead et al.<sup>98</sup> established the value of a modified CODOX-M/IVAC regimen in adults with Burkitt's lymphoma. Patients at low-risk were treated with 3 cycles of modified CODOX-M and those at high-risk with 4 cycles of modified CODOX-M and IVAC. In low-risk patients, 2-year event-free and overall survival were 83% and 81%, respectively, compared with 60% and 70% for high-risk patients. Modified CODOX-M regimen was also effective and well tolerated in elderly patients with Burkitt's or Burkitt's-like lymphoma.<sup>99</sup>

A regimen of hyperCVAD (hyperfractionated cyclophosphamide, vincristine, doxorubicin, and dexamethasone) alternating with methotrexate and cytarabine (including intrathecal methotrexate) was evaluated in a trial of 26 patients with Burkitt's-like ALL.<sup>100</sup> The complete response rate was 81% and the 3-year overall survival rate was 49%. Overall survival was higher in patients younger than 60 years (77% vs. 17% in patients > 60 years).

The CALGB 9251 study evaluated the efficacy of intensive chemotherapy with and without cranial ra-

diation for central nervous system prophylaxis in adult patients with Burkitt's leukemia or lymphoma.<sup>101</sup> Given the severe neurotoxicity, the protocol was amended after the first 52 of 92 patients were enrolled. The 3-year event-free survival rate was 52% in the cohort of patients who received intensive central nervous system prophylaxis (cranial radiotherapy and 12 doses of triple intrathecal chemotherapy), compared with 45% in those treated with only 6 doses chemotherapy and cranial irradiation.

The HOVON group showed the feasibility and efficacy of intensive high-dose induction chemotherapy (prednisone, cyclophosphamide, doxorubicin, etoposide, and mitoxantrone, without high-dose methotrexate or high-dose cytarabine) followed by consolidation with BEAM (carmustine, etoposide, cytarabine, melphalan) and autologous stem cell transplant in untreated adults with Burkitt's or Burkitt's-like lymphoma.<sup>102</sup> In this study, the 5-year overall and event-free survival rates were 81% and 73%, respectively, for patients with Burkitt's or Burkitt's-like lymphoma. In a small series of patients with Burkitt's or Burkitt's-like lymphoma, the high-dose CHOP with mid-cycle methotrexate regimen produced response and event-free survival rates comparable to other regimens, with an acceptable toxicity profile.<sup>103</sup>

Given that Burkitt's lymphoma is CD20+, the addition of rituximab to chemotherapy has also been investigated. Thomas et al.<sup>104</sup> evaluated the addition of rituximab to hyperCVAD regimen in a phase II trial involving 31 patients with newly diagnosed Burkitt's lymphoma or Burkitt's ALL. The initial report showed encouraging results, with an 86% complete response rate. The 3-year event-free and disease-free survival rates were 80%, and 88%, respectively. The 3-year overall survival rates (89% vs. 88%) were similar in elderly and younger patients.<sup>104</sup> In the updated report, with a median follow-up of 46 months, 4-year overall survival rates (75% vs. 50%) and overall survival rates in patients younger than 60 (76% vs. 70%) and those 60 years or older (72% vs. 19%) were superior for hyperCVAD with rituximab, in historical comparison with patients treated with hyperCVAD alone.<sup>105</sup> The results of this study showed that the addition of rituximab to hyperCVAD improves long-term outcome, particularly in elderly patients.

Hoelzer<sup>106</sup> recently reported the results of a large prospective study, which showed a substantial im-

## Non-Hodgkin's Lymphoma

provement in the overall survival of younger and older patients with Burkitt's lymphoma treated with rituximab in combination with an intensive chemotherapy regimen developed by GMALL. The 3-year overall survival rate was 91%.

In a recent prospective study, dose-adjusted EPOCH (etoposide, prednisone, vincristine, cyclophosphamide, and doxorubicin) with rituximab was highly effective in both HIV-positive and -negative patients with Burkitt's lymphoma, with no central nervous system involvement at diagnosis. Overall and progression-free survival were 100% and 95%, respectively, with a median follow-up of 27 months.<sup>107</sup>

The management of patients with B-cell lymphoma, unclassifiable, with features intermediate between DLBCL and Burkitt's lymphoma, and patients with "double-hit" lymphoma, has not been well studied. Outcomes of CHOP with rituximab (R-CHOP) chemotherapy are poor. In a recent report, Mead et al.<sup>108</sup> evaluated the CODOX-M regimen (with or without IVAC based on the risk status) in patients with high-grade B-cell lymphomas. Patients with Burkitt's lymphoma had superior outcomes than those without, which was characterized by a germinal center phenotype, absence of BCL2 expression, abnormal TP53 expression, presence of MYC rearrangement, and the absence of t(14;18) or 3q27 rearrangements.

### NCCN Recommendations

These guidelines recommend the following chemotherapy regimens for both high- and low-risk patients (pages 292 and 293):

- Modified CODOX-M with or without rituximab (3 cycles) for low-risk patients (completely resected abdominal lesions or a single extra-abdominal mass and normal LDH level).
- Modified CODOX-M/IVAC with or without rituximab (4 cycles) for high-risk patients.
- HyperCVAD with rituximab, dose-adjusted EPOCH plus rituximab, or CALGB 9251 regimen.

Disease relapse after 2 years is rare after complete remission to induction therapy, and follow-up should be individualized according to patient's characteristics. Patients with relapsed or refractory disease should be treated in the context of a clinical trial whenever possible. High-dose therapy and autologous stem cell transplantation is an appropriate option for patients with relapsed disease.

## Lymphoblastic Lymphoma

### Overview

Lymphoblastic lymphoma is a rare disease that represents only 2% of all the NHLs in adults. Most (80%–90%) lymphoblastic lymphoma is a T-cell malignancy that usually occurs in young men. T-cell lymphoblastic lymphoma is a clinically aggressive disease with frequent involvement of extranodal sites, particularly the bone marrow and central nervous system.

### Diagnosis

Immunophenotyping studies are essential to distinguish between the precursor T- and B-cell lymphoblastic lymphoma. Typical immunophenotypes of precursor B-cell lymphoblastic lymphomas include dim expression of slg-, CD10+/-, CD19+, CD20-/+ , TdT+, and precursor T-cell lymphoblastic lymphomas are characterized by dim expression of slg-, CD10-, CD1a+/-, CD2+, CD3-/+ , CD4/8+/, CD7+, CD19/20-, and TdT+.

### Workup

The initial diagnostic workup for lymphoblastic lymphoma includes a detailed physical examination (with special attention to node-bearing areas, liver, and spleen) and CT scans of the chest, abdomen, and pelvis (page 294). Bone marrow aspiration, biopsy, and lumbar puncture are essential. If the treatment includes an anthracycline-containing regimen, pretreatment cardiac evaluation with MUGA scan or echocardiogram is recommended. If significant cardiac dysfunction is identified, cardiac consultation is necessary before the use of anthracyclines or anthracenediones.

### Treatment

The prognosis of adult lymphoblastic lymphomas treated with regimens used for other subtypes of aggressive NHLs has generally been poor.<sup>109</sup> Lymphoblastic lymphoma has generally been treated with regimens appropriate for ALL.<sup>110</sup> TLS is more common in patients with lymphoblastic lymphoma and should be managed as outlined in the section on Tumor Lysis Syndrome (page 323).

The 5-drug intensive chemotherapy (dose-intensive cyclophosphamide and anthracycline, standard-dose vincristine and asparaginase, and intrathecal methotrexate) used in CALGB 8811 for adult patients with ALL produced a complete response rate of

## Non-Hodgkin's Lymphoma

85%.<sup>111</sup> The response rate was 94% in patients younger than 30 years. The estimated 3-year overall survival rate was 69% for patients younger than 30 years, 39% for those 30 to 59 years, and 17% in patients older than 60 years.

Another study from German multicenter ALL study group also reported a favorable outcome in adult patients with lymphoblastic lymphoma treated with the BFM ALL regimen (8-drug induction chemotherapy involving prednisone, vincristine, daunorubicin, L-asparaginase, cyclophosphamide, cytarabine, 6-mercaptopurine, and intrathecal methotrexate, including prophylactic cranial and mediastinal irradiation followed by consolidation and reinduction therapy).<sup>112</sup> Overall, 42 patients (93%) experienced a complete response. The estimated 7-year overall survival, durable remission, and disease-free survival rates were 51%, 65%, and 62%, respectively.

In a study conducted by M. D. Anderson Cancer Center, patients with lymphoblastic lymphoma treated with the hyperCVAD regimen experienced a 91% complete response rate. The 3-year progression-free (66%) and overall survival rates (70%) compared favorably with the previously published results for ALL regimens.<sup>113,114</sup> In this trial, radiotherapy was recommended for all patients with mediastinal disease to reduce the risk for mediastinal recurrence. After the completion of induction therapy, patients underwent maintenance therapy with the POMP (mercaptopurine, methotrexate, vincristine, and prednisone) regimen.<sup>115</sup>

High-dose therapy with hematopoietic stem cell transplant (HSCT) has also been investigated to consolidate complete remission after induction therapy.<sup>116,117</sup> Adults with lymphoblastic lymphoma experiencing first remission showed a trend toward improved relapse-free survival with use of ASCT, but no improvement in overall survival was seen compared with conventional-dose therapy.<sup>117</sup> In another report from IBMTR, patients who underwent allogeneic HSCT had significantly lower relapse rates at 1 and 5 years than those who underwent ASCT (32% vs. 46%, respectively), but showed no significant difference in 5-year lymphoma-free survival rates (36% vs. 39%, respectively), although allogeneic HSCT was also associated with higher toxicity and treatment-related mortality.<sup>116</sup> In a more recent report, a German study group reported that adult patients with relapsed ALL who proceeded directly to allogeneic HSCT had

better outcomes than those who received reinduction chemotherapy before transplantation.<sup>118</sup>

### NCCN Recommendations

Patients with stage I to IV disease can be treated with any of the regimens listed on pages 296 and 297 (BFM regimen, CALGB ALL regimen, hyperCVAD followed by POMP maintenance, or LMB-86 regimen) or in clinical trials. Maintenance chemotherapy (up to 2 years) based on the treatment protocol is recommended. Poor-risk patients can be considered for high-dose therapy with autologous or allogeneic stem cell rescue. Patients with complete response to induction therapy can be observed or treated in clinical trials. Patients with biopsy-proven partial response are considered to have experienced failed treatment and should proceed to second-line therapy (page 295).

These guidelines recommend reinduction with combination chemotherapy or allogeneic HSCT for patients experiencing relapsed disease (page 295). Enrollment in clinical trials is encouraged to refine these approaches, and the most appropriate therapy should be chosen in consultation with an expert in lymphoma.

## AIDS-Related B-Cell Lymphoma

### Overview

AIDS-related lymphoma (ARL) is usually an AIDS-defining diagnosis in patients infected with HIV. Before the development of highly active antiretroviral therapy (HAART), ARL often presented with widespread extranodal disease, central nervous system involvement, and poor prognosis.<sup>119</sup> However, the incidence of HIV-associated lymphoma has fallen in the HAART era.<sup>120</sup> With the use of combination antiretroviral therapy, the survival of patients diagnosed with HIV-related systemic NHL has improved, with two thirds of patients surviving for longer than 1 year after diagnosis.<sup>121</sup> Burkitt's lymphoma and DLBCL are the most common forms of ARLs. Patients who develop Burkitt's lymphoma generally have higher CD4 counts, although a small fraction may present with CD4 counts less than 100. Primary central nervous system lymphoma develops in patients with very low CD4 counts and is most often seen in uncontrolled AIDS. DLBCL occurs in patients between these extremes.



## Non-Hodgkin's Lymphoma

Plasmablastic lymphoma and primary effusion lymphoma are seen more commonly in patients with HIV than in those without. Primary effusion lymphoma accounts for fewer than 5% of the ARL cases, most often occurring in the pleural, pericardial, and abdominal cavities.<sup>122,123</sup> Primary effusion lymphomas are associated with HHV8 infection, and many are also coinfecting with EBV. Plasmablastic lymphoma is another unique large B-cell lymphoma that mainly involves the jaw and oral cavity of HIV-infected patients.<sup>124</sup> Multicentric Castleman's disease is prevalent in HIV-infected individuals and has also been associated with HHV8 infection and increased incidence of lymphoma.<sup>125</sup>

### Diagnosis

The diagnostic evaluation of HIV-associated lymphoma is not different from the non-HIV-associated disease. The major factor is to distinguish between Burkitt's lymphoma and DLBCL. Hodgkin and indolent lymphomas are seen at a higher incidence in patients with HIV than the general population, but are much less common than Burkitt's lymphoma or DLBCL.

### Workup

Diagnostic evaluation is as outlined earlier for Burkitt's lymphoma. However, all patients (despite histology) should have a lumbar puncture to rule out central nervous system involvement. In addition, baseline values for CD4 counts and viral load should be obtained (page 298).

### Treatment

Optimal management of HIV-associated lymphoma is not established. However, several key factors have emerged as being important to improve outcome. In general, studies have shown early introduction of HAART therapy to be associated with superior outcomes, which has allowed for the administration of more dose-intensive regimens and a reduction in treatment-associated toxicity.<sup>126,127</sup>

In the NHL HIV 93 trial of risk-adapted intensive chemotherapy in patients with ARL, Mounier et al.<sup>128</sup> reported that HIV score, IPI (international prognostic index) score, and HAART affect survival in patients with ARL but not the intensity of the chemotherapy. Combination chemotherapy regimens such as CHOP or CDE (cyclophosphamide, doxorubicin, and etoposide) given with concomitant HAART,<sup>129-131</sup> or the EPOCH regimen given

without HAART,<sup>132</sup> have been proven effective and tolerable in patients with ARL.

In the HAART era, the median survival of patients with HIV-associated DLBCL is similar to those with non-HIV-associated DLBCL. There has been conflicting data regarding the outcomes of patients with HIV-associated Burkitt's lymphoma. One study showed a median survival of only 6 months.<sup>133</sup> However, a retrospective analysis by Wang et al.<sup>134</sup> reported that HIV-positive and -negative patients with Burkitt's lymphoma had similar outcomes when treated with CODOX-M/IVAC.

The safety and efficacy of rituximab in combination with chemotherapy has also been evaluated in clinical trials. In the only randomized phase III trial conducted by the AIDS Malignancies Consortium (AMC), the addition of rituximab to CHOP increased the risk for neutropenia and infection, particularly in patients with CD4 counts of less than 50, and showed no net benefit in patients with HIV-associated lymphoma, although it was associated with improved tumor responses.<sup>135</sup> In subsequent phase II trials, however, rituximab in combination with CHOP or infusional CDE regimens was feasible and highly effective, with an acceptable toxicity level in patients with ARL.<sup>136-138</sup> Long-term follow-up of patients with ARL treated with combination rituximab and CDE concomitantly with HAART produced a complete response rate of 70%, and time to treatment failure at 5 years was 52%, which are comparable to those observed in non-HIV-positive patients.<sup>139</sup>

In a recent report, Dunleavy et al.<sup>140</sup> showed that the addition of rituximab to the EPOCH regimen is highly effective and tolerable in patients with ARL, and enables the administration of fewer treatment cycles. In this study, the addition of rituximab did not seem to cause serious infection-related complications or deaths. The AMC trial evaluated the use of sequential versus concurrent rituximab in combination with the EPOCH regimen. In this phase II randomized trial, complete response was observed in 73% and 55% of evaluable patients in the concurrent and sequential arms, respectively.<sup>141</sup> Toxicity was comparable in the arms, although patients with a baseline CD4 count of less than 50 had a high infectious death rate in the concurrent arm. The 2-year progression-free survival rates in the concurrent and sequential arms were 64% and 60%, re-

## Non-Hodgkin's Lymphoma

spectively. The authors concluded that concurrent rituximab plus infusional EPOCH is an effective regimen for HIV-associated lymphoma, which merits further evaluation.

**NCCN Recommendations**

These guidelines recommend the use of HAART and growth factor support along with full-dose chemotherapy (page 299). Prophylaxis with intrathecal chemotherapy has also emerged as an important component of care in patients with DLBCL.

Patients with AIDS-related Burkitt's lymphoma should be treated with chemotherapy (with or without rituximab), such as CODOX-M alternating with IVAC, dose-adjusted EPOCH, CDE, or CHOP chemotherapy with or without high-dose methotrexate (not exceeding 3 g/m<sup>2</sup>).

Patients with AIDS-related DLBCL should be treated with dose-adjusted EPOCH, CDE, CHOP, or CDOP (cyclophosphamide, liposomal doxorubicin, vincristine, and prednisone). The omission of rituximab is strongly suggested for those with CD4 counts of less than 100 because of the higher risk for infectious toxicities. Patients with lymphoma associated with multicentric Castleman's disease and primary effusion lymphoma can also be treated with the same regimens described for patients with DLBCL. Because most cases of primary effusion lymphoma are CD20<sup>−</sup>, the addition of rituximab is not indicated.

Plasmablastic lymphoma was associated with a poor prognosis in the pre-HAART era, but prognosis is now better when intensive chemotherapy regimens are used along with HAART. Outcome of HIV-positive patients with plasmablastic lymphoma treated at the Memorial Sloan-Kettering Cancer Center were superior to most reports in the literature.<sup>142</sup> Among 6 patients treated with anthracycline-based multiagent chemotherapy along with HAART, 5 were alive and disease-free, with a median follow-up of 22 months. These guidelines recommend CODOX-M/IVAC, EPOCH, or hyperCVAD regimens for patients with plasmablastic lymphoma.

Primary central nervous system lymphoma is associated with severe immunosuppression and poor prognosis. In a retrospective study, patients with primary central nervous system lymphoma treated with HAART and radiotherapy had a more favorable outcome.<sup>79</sup> High-dose methotrexate, radiotherapy, or antiretroviral therapy can be considered for these patients.

**References**

1. Jemal A, Siegel R, Ward E, et al. Cancer statistics, 2009. *CA Cancer J Clin* 2009;59:225–249.
2. Groves FD, Linet MS, Travis LB, Devesa SS. Cancer surveillance series: non-Hodgkin's lymphoma incidence by histologic subtype in the United States from 1978 through 1995. *J Natl Cancer Inst* 2000;92:1240–1251.
3. Rappaport H. Tumors of the hematopoietic system. In Lukes RJ, Collins RD. *Atlas of Tumor Pathology Series*, ed. I. Washington, D.C.: Armed Forces Institute of Pathology; 1966.
4. Hicks EB, Rappaport H, Winter WJ. Follicular lymphoma; a re-evaluation of its position in the scheme of malignant lymphoma, based on a survey of 253 cases. *Cancer* 1956;9:792–821.
5. Bannetta MH, Farrer-Brown G, Henry K, et al. Classification of non-Hodgkin's lymphomas. *Lancet* 1974;2:405–408.
6. Lennert K. *Malignant Lymphomas Other Than Hodgkin's Disease*. New York: Springer-Verlag; 1978.
7. Lennert K, Feller A. *Histopathology of Non-Hodgkin's Lymphomas*, 2nd ed. New York: Springer-Verlag; 1992.
8. National Cancer Institute sponsored study of classifications of non-Hodgkin's lymphomas: summary and description of a working formulation for clinical usage. The Non-Hodgkin's Lymphoma Pathologic Classification Project. *Cancer* 1982;49:2112–2135.
9. Classification of non-Hodgkin's lymphomas. Reproducibility of major classification systems. NCI non-Hodgkin's Classification Project Writing Committee. *Cancer* 1985;55:91–95.
10. Harris N, Jaffe E, Stein H, et al. A revised European-American classification of lymphoid neoplasms: a proposal from the International Lymphoma Study Group [see comments]. *Blood* 1994;84:1361–1392.
11. A clinical evaluation of the International Lymphoma Study Group classification of non-Hodgkin's lymphoma. The Non-Hodgkin's Lymphoma Classification Project. *Blood* 1997;89:3909–3918.
12. Armitage JO, Weisenburger DD. New approach to classifying non-Hodgkin's lymphomas: clinical features of the major histologic subtypes. Non-Hodgkin's Lymphoma Classification Project. *J Clin Oncol* 1998;16:2780–2795.
13. Harris NL, Jaffe ES, Diebold J, et al. World Health Organization classification of neoplastic diseases of the hematopoietic and lymphoid tissues: report of the Clinical Advisory Committee Meeting - Airlie House, Virginia, November 1997. *J Clin Oncol* 1999;17:3835–3849.
14. Jaffe ES, Harris NL, Stein H, Vardiman JW. *WHO Classification of Tumours. Pathology and Genetics of Tumours of Haematopoietic and Lymphoid Tissues*. Lyon: IARC; 2001.
15. Vose J, Armitage J, Weisenburger D. International peripheral T-cell and natural killer/T-cell lymphoma study: pathology findings and clinical outcomes. *J Clin Oncol* 2008;26:4124–4130.
16. Jaffe ES, Harris NL, Stein H, Isaacson PG. Classification of lymphoid neoplasms: the microscope as a tool for disease discovery. *Blood* 2008;112:4384–4399.
17. Swerdlow SH, Campo E, Harris NL, et al. *WHO Classification of Tumours of Haematopoietic and Lymphoid Tissues*. Lyon: IARC; 2008.
18. Hallek M, Cheson BD, Catovsky D, et al. Guidelines for the diagnosis and treatment of chronic lymphocytic leukemia: a report from the International Workshop on Chronic Lymphocytic Leukemia (IWCLL) updating the National Cancer Institute-Working Group (NCI-WG) 1996 guidelines. *Blood* 2008;111:5446–5456.

## Non-Hodgkin's Lymphoma

19. Katzenberger T, Ott G, Klein T, et al. Cytogenetic alterations affecting BCL6 are predominantly found in follicular lymphomas grade 3B with a diffuse large B-cell component. *Am J Pathol* 2004;165:481–490.
20. Hans CP, Weisenburger DD, Vose JM, et al. A significant diffuse component predicts for inferior survival in grade 3 follicular lymphoma, but cytologic subtypes do not predict survival. *Blood* 2003;101:2363–2367.
21. Cong P, Raffeld M, Teruya-Feldstein J, et al. In situ localization of follicular lymphoma: description and analysis by laser capture microdissection. *Blood* 2002;99:3376–3382.
22. Willemze R, Jaffe ES, Burg G, et al. WHO-EORTC classification for cutaneous lymphomas. *Blood* 2005;105:3768–3785.
23. Hoefnagel JJ, Dijkman R, Basso K, et al. Distinct types of primary cutaneous large B-cell lymphoma identified by gene expression profiling. *Blood* 2005;105:3671–3678.
24. Grange F, Bekkenk MW, Wechsler J, et al. Prognostic factors in primary cutaneous large B-cell lymphomas: a European multicenter study. *J Clin Oncol* 2001;19:3602–3610.
25. Willemze R, Meijer CJ, Sentis HJ, et al. Primary cutaneous large cell lymphomas of follicular center cell origin. A clinical follow-up study of nineteen patients. *J Am Acad Dermatol* 1987;16:518–526.
26. Alizadeh AA, Eisen MB, Davis RE, et al. Distinct types of diffuse large B-cell lymphoma identified by gene expression profiling. *Nature* 2000;403:503–511.
27. Choi WW, Weisenburger DD, Greiner TC, et al. A new immunostain algorithm classifies diffuse large B-cell lymphoma into molecular subtypes with high accuracy. *Clin Cancer Res* 2009;15:5494–5502.
28. Hans CP, Weisenburger DD, Greiner TC, et al. Confirmation of the molecular classification of diffuse large B-cell lymphoma by immunohistochemistry using a tissue microarray. *Blood* 2004;103:275–282.
29. Fu K, Weisenburger DD, Choi WW, et al. Addition of rituximab to standard chemotherapy improves the survival of both the germinal center B-cell-like and non-germinal center B-cell-like subtypes of diffuse large B-cell lymphoma. *J Clin Oncol* 2008;26:4587–4594.
30. Nyman H, Adde M, Karjalainen-Lindsberg ML, et al. Prognostic impact of immunohistochemically defined germinal center phenotype in diffuse large B-cell lymphoma patients treated with immunochemotherapy. *Blood* 2007;109:4930–4935.
31. Ferry JA. Burkitt's lymphoma: clinicopathologic features and differential diagnosis. *Oncologist* 2006;11:375–383.
32. Dave SS, Fu K, Wright GW, et al. Molecular diagnosis of Burkitt's lymphoma. *N Engl J Med* 2006;354:2431–2442.
33. Hummel M, Bentink S, Berger H, et al. A biologic definition of Burkitt's lymphoma from transcriptional and genomic profiling. *N Engl J Med* 2006;354:2419–2430.
34. Macpherson N, Lesack D, Klasa R, et al. Small noncleaved, non-Burkitt's (Burkitt-like) lymphoma: cytogenetics predict outcome and reflect clinical presentation. *J Clin Oncol* 1999;17:1558–1567.
35. Barth TF, Leithauser F, Joos S, et al. Mediastinal (thymic) large B-cell lymphoma: where do we stand? *Lancet Oncol* 2002;3:229–234.
36. Rosenwald A, Wright G, Leroy K, et al. Molecular diagnosis of primary mediastinal B cell lymphoma identifies a clinically favorable subgroup of diffuse large B cell lymphoma related to Hodgkin lymphoma. *J Exp Med* 2003;198:851–862.
37. Traverse-Glehen A, Pittaluga S, Gaulard P, et al. Mediastinal gray zone lymphoma: the missing link between classic Hodgkin's lymphoma and mediastinal large B-cell lymphoma. *Am J Surg Pathol* 2005;29:1411–1421.
38. Falini B, Pileri S, Zinzani PL, et al. ALK+ lymphoma: clinicopathological findings and outcome. *Blood* 1999;93:2697–2706.
39. Gascoyne RD, Aoun P, Wu D, et al. Prognostic significance of anaplastic lymphoma kinase (ALK) protein expression in adults with anaplastic large cell lymphoma. *Blood* 1999;93:3913–3921.
40. Savage KJ, Harris NL, Vose JM, et al. ALK- anaplastic large-cell lymphoma is clinically and immunophenotypically different from both ALK+ ALCL and peripheral T-cell lymphoma, not otherwise specified: report from the International Peripheral T-Cell Lymphoma Project. *Blood* 2008;111:5496–5504.
41. Cheson BD, Horning SJ, Coiffier B, et al. Report of an international workshop to standardize response criteria for non-Hodgkin's lymphomas. *J Clin Oncol* 1999;17:1244–1253.
42. Cheson BD, Pfistner B, Juweid ME, et al. Revised response criteria for malignant lymphoma. *J Clin Oncol* 2007;25:579–586.
43. Hehn ST, Grogan TM, Miller TP. Utility of fine-needle aspiration as a diagnostic technique in lymphoma. *J Clin Oncol* 2004;22:3046–3052.
44. Meda BA, Buss DH, Woodruff RD, et al. Diagnosis and subclassification of primary and recurrent lymphoma. *Am J Clin Pathol* 2000;113:688–699.
45. Dong HY, Harris NL, Preffer FI, Pitman MB. Fine-needle aspiration biopsy in the diagnosis and classification of primary and recurrent lymphoma: a retrospective analysis of the utility of cytomorphology and flow cytometry. *Mod Pathol* 2001;14:472–481.
46. Jeffers M, Milton J, Herriot R, McKean M. Fine needle aspiration cytology in the investigation on non-Hodgkin's lymphoma. *J Clin Pathol* 1998;51:189–196.
47. Zeppa P, Marino G, Troncone G, Fulciniti F. Fine-needle cytology and flow cytometry immunophenotyping and subclassification of non-Hodgkin lymphoma. *Cancer* 2004;102:55–65.
48. Dunphy CH. Applications of flow cytometry and immunohistochemistry to diagnostic hematopathology. *Arch Pathol Lab Med* 2004;128:1004–1022.
49. Yang WI, Zukerberg LR, Motokura T, et al. Cyclin D1 (Bcl-1, PRAD1) protein expression in low-grade B-cell lymphomas and reactive hyperplasia. *Am J Pathol* 1994;145:86–96.
50. Zukerberg LR, Yang WI, Arnold A, Harris NL. Cyclin D1 expression in non-Hodgkin's lymphomas. Detection by immunohistochemistry. *Am J Clin Pathol* 1995;103:756–760.
51. Vega F, Medeiros LJ. Chromosomal translocations involved in non-Hodgkin lymphomas. *Arch Pathol Lab Med* 2003;127:1148–1160.
52. Ohno H, Fukuhara S. Significance of rearrangement of the BCL6 gene in B-cell lymphoid neoplasms. *Leuk Lymphoma* 1997;27:53–63.
53. Tsuboi K, Iida S, Inagaki H, et al. MUM1/IRF4 expression as a frequent event in mature lymphoid malignancies. *Leukemia* 2000;14:449–456.
54. Laurent C, Do C, Gascoyne RD, et al. Anaplastic lymphoma kinase-positive diffuse large B-cell lymphoma: a rare clinicopathologic entity with poor prognosis. *J Clin Oncol* 2009;27:4211–4216.

## Non-Hodgkin's Lymphoma

55. Willemze R. Primary cutaneous B-cell lymphoma: classification and treatment. *Curr Opin Oncol* 2006;18:425–431.
56. Berti E, Tomasini D, Vermeer MH, et al. Primary cutaneous CD8-positive epidermotropic cytotoxic T cell lymphomas: a distinct clinicopathological entity with an aggressive clinical behavior. *Am J Pathol* 1999;155:483–492.
57. Howell SJ, Shalet SM. Fertility preservation and management of gonadal failure associated with lymphoma therapy. *Curr Oncol Rep* 2002;4:443–452.
58. Conlan M, Bast M, Armitage J, Weisenburger D. Bone marrow involvement by non-Hodgkin's lymphoma: the clinical significance of morphologic discordance between the lymph node and bone marrow. Nebraska Lymphoma Study Group. *J Clin Oncol* 1990;8:1163–1172.
59. Lim ST, Tao M, Cheung YB, et al. Can patients with early-stage diffuse large B-cell lymphoma be treated without bone marrow biopsy? *Ann Oncol* 2005;16:215–218.
60. Kim YH, Willemze R, Pimpinelli N, et al. TNM classification system for primary cutaneous lymphomas other than mycosis fungoides and Sezary syndrome: a proposal of the International Society for Cutaneous Lymphomas (ISCL) and the Cutaneous Lymphoma Task Force of the European Organization of Research and Treatment of Cancer (EORTC). *Blood* 2007;110:479–484.
61. Senff NJ, Kluin-Nelemans HC, Willemze R. Results of bone marrow examination in 275 patients with histological features that suggest an indolent type of cutaneous B-cell lymphoma. *Br J Haematol* 2008;142:52–56.
62. Juneja SK, Wolf MM, Cooper IA. Value of bilateral bone marrow biopsy specimens in non-Hodgkin's lymphoma. *J Clin Pathol* 1990;43:630–632.
63. Seam P, Juweid ME, Cheson BD. The role of FDG-PET scans in patients with lymphoma. *Blood* 2007;110:3507–3516.
64. Isasi CR, Lu P, Blaufox MD. A metaanalysis of 18F-2-deoxy-2-fluoro-D-glucose positron emission tomography in the staging and restaging of patients with lymphoma. *Cancer* 2005;104:1066–1074.
65. Rodriguez-Vigil B, Gomez-Leon N, Pinilla I, et al. PET/CT in lymphoma: prospective study of enhanced full-dose PET/CT versus unenhanced low-dose PET/CT. *J Nucl Med* 2006;47:1643–1648.
66. Schaefer NG, Hany TF, Taverna C, et al. Non-Hodgkin lymphoma and Hodgkin disease: coregistered FDG PET and CT at staging and restaging—do we need contrast-enhanced CT? *Radiology* 2004;232:823–829.
67. Lau GK. Hepatitis B reactivation after chemotherapy: two decades of clinical research. *Hepatol Int* 2008;2:152–162.
68. Lok AS, Liang RH, Chiu EK, et al. Reactivation of hepatitis B virus replication in patients receiving cytotoxic therapy. Report of a prospective study. *Gastroenterology* 1991;100:182–188.
69. Targhetta C, Cabras MG, Mamusa AM, et al. Hepatitis B virus-related liver disease in isolated anti-hepatitis B-core positive lymphoma patients receiving chemo- or chemo-immune therapy. *Haematologica* 2008;93:951–952.
70. Lalazar G, Rund D, Shouval D. Screening, prevention and treatment of viral hepatitis B reactivation in patients with haematological malignancies. *Br J Haematol* 2007;136:699–712.
71. Loomba R, Rowley A, Wesley R, et al. Systematic review: the effect of preventive lamivudine on hepatitis B reactivation during chemotherapy. *Ann Intern Med* 2008;148:519–528.
72. Tsutsumi Y, Tanaka J, Kawamura T, et al. Possible efficacy of lamivudine treatment to prevent hepatitis B virus reactivation due to rituximab therapy in a patient with non-Hodgkin's lymphoma. *Ann Hematol* 2004;83:58–60.
73. Tsutsumi Y, Kawamura T, Saitoh S, et al. Hepatitis B virus reactivation in a case of non-Hodgkin's lymphoma treated with chemotherapy and rituximab: necessity of prophylaxis for hepatitis B virus reactivation in rituximab therapy. *Leuk Lymphoma* 2004;45:627–629.
74. Lau GK, Yiu HH, Fong DY, et al. Early is superior to deferred preemptive lamivudine therapy for hepatitis B patients undergoing chemotherapy. *Gastroenterology* 2003;125:1742–1749.
75. Carson KR, Evens AM, Richey EA, et al. Progressive multifocal leukoencephalopathy after rituximab therapy in HIV-negative patients: a report of 57 cases from the Research on Adverse Drug Events and Reports project. *Blood* 2009;113:4834–4840.
76. O'Brien SM, Keating MJ, Mocarski ES. Updated guidelines on the management of cytomegalovirus reactivation in patients with chronic lymphocytic leukemia treated with alemtuzumab. *Clin Lymphoma Myeloma* 2006;7:125–130.
77. Dearden C. Disease-specific complications of chronic lymphocytic leukemia. *Hematology Am Soc Hematol Educ Program* 2008;2008:450–456.
78. Berentsen S. Rituximab for the treatment of autoimmune cytopenias. *Haematologica* 2007;92:1589–1596.
79. Newell ME, Hoy JF, Cooper SG, et al. Human immunodeficiency virus-related primary central nervous system lymphoma. *Cancer* 2004;100:2627–2636.
80. Godeau B, Porcher R, Fain O, et al. Rituximab efficacy and safety in adult splenectomy candidates with chronic immune thrombocytopenic purpura: results of a prospective multicenter phase 2 study. *Blood* 2008;112:999–1004.
81. Bussell JB, Kuter DJ, Pullarkat V, et al. Safety and efficacy of long-term treatment with romiplostim in thrombocytopenic patients with chronic ITP. *Blood* 2009;113:2161–2171.
82. Kuter DJ, Bussell JB, Lyons RM, et al. Efficacy of romiplostim in patients with chronic immune thrombocytopenic purpura: a double-blind randomised controlled trial. *Lancet* 2008;371:395–403.
83. Bussell JB, Kuter DJ, Newland A, et al. Long-term efficacy and safety of romiplostim for the treatment of patients with chronic immune thrombocytopenia (ITP): 5-year update from an open-label extension study [abstract]. *Blood* 2009;114:Abstract 681.
84. Bussell JB, Cheng G, Saleh MN, et al. Eltrombopag for the treatment of chronic idiopathic thrombocytopenic purpura. *N Engl J Med* 2007;357:2237–2247.
85. D'Arena G, Cascavilla N. Chronic lymphocytic leukemia-associated pure red cell aplasia. *Int J Immunopathol Pharmacol* 2009;22:279–286.
86. Coiffier B, Altman A, Pui CH, et al. Guidelines for the management of pediatric and adult tumor lysis syndrome: an evidence-based review. *J Clin Oncol* 2008;26:2767–2778.
87. Cairo MS, Bishop M. Tumor lysis syndrome: new therapeutic strategies and classification. *Br J Haematol* 2004;127:3–11.
88. Krakoff IH, Meyer RL. Prevention of hyperuricemia in leukemia and lymphoma: use of allopurinol, a xanthine oxidase inhibitor. *JAMA* 1965;193:1–6.
89. Bosly A, Sonet A, Pinkerton CR, et al. Rasburicase (recombinant urate oxidase) for the management of hyperuricemia in patients

## Non-Hodgkin's Lymphoma

- with cancer: report of an international compassionate use study. *Cancer* 2003;98:1048–1054.
90. Coiffier B, Mounier N, Bologna S, et al. Efficacy and safety of rasburicase (recombinant urate oxidase) for the prevention and treatment of hyperuricemia during induction chemotherapy of aggressive non-Hodgkin's lymphoma: results of the GRAAL1 (Groupe d'Etude des Lymphomes de l'Adulte Trial on Rasburicase Activity in Adult Lymphoma) study. *J Clin Oncol* 2003;21:4402–4406.
  91. Cortes J, Seiter K, Maziarz RT, et al. Superiority of rasburicase versus allopurinol on serum uric acid control in adult patients with hematological malignancies at risk of developing tumor lysis syndrome: results of a randomized comparative phase III study [abstract]. *Blood* 2008;112:Abstract 919.
  92. Aldoss IT, Weisenburger DD, Fu K, et al. Adult Burkitt lymphoma: advances in diagnosis and treatment. *Oncology (Williston Park)* 2008;22:1508–1517.
  93. Blum KA, Lozanski G, Byrd JC. Adult Burkitt leukemia and lymphoma. *Blood* 2004;104:3009–3020.
  94. Burmeister T, Schwartz S, Horst HA, et al. Molecular heterogeneity of sporadic adult Burkitt-type leukemia/lymphoma as revealed by PCR and cytogenetics: correlation with morphology, immunology and clinical features. *Leukemia* 2005;19:1391–1398.
  95. Friedberg JW, Ciminello L, Kelly J, et al. Outcome of patients > age 40 with Burkitt lymphoma (BL) treated with aggressive chemotherapeutic regimens: results from the International Burkitt Lymphoma Collaborative Group [abstract]. *Blood* 2005;106:Abstract 928.
  96. Magrath I, Adde M, Shad A, et al. Adults and children with small non-cleaved-cell lymphoma have a similar excellent outcome when treated with the same chemotherapy regimen. *J Clin Oncol* 1996;14:925–934.
  97. Adde M, Shad A, Venzon D, et al. Additional chemotherapy agents improve treatment outcome for children and adults with advanced B-cell lymphomas. *Semin Oncol* 1998;25:33–39; discussion 45–38.
  98. Mead GM, Sydes MR, Walewski J, et al. An international evaluation of CODOX-M and CODOX-M alternating with IVAC in adult Burkitt's lymphoma: results of United Kingdom Lymphoma Group LY06 study. *Ann Oncol* 2002;13:1264–1274.
  99. Lacasce A, Howard O, Lib S, et al. Modified Magrath regimens for adults with Burkitt and Burkitt-like lymphomas: preserved efficacy with decreased toxicity. *Leuk Lymphoma* 2004;45:761–767.
  100. Thomas DA, Cortes J, O'Brien S, et al. Hyper-CVAD program in Burkitt's-type adult acute lymphoblastic leukemia. *J Clin Oncol* 1999;17:2461–2470.
  101. Rizzieri DA, Johnson JL, Niedzwiecki D, et al. Intensive chemotherapy with and without cranial radiation for Burkitt leukemia and lymphoma: final results of Cancer and Leukemia Group B Study 9251. *Cancer* 2004;100:1438–1448.
  102. van Imhoff GW, van der Holt B, MacKenzie MA, et al. Short intensive sequential therapy followed by autologous stem cell transplantation in adult Burkitt, Burkitt-like and lymphoblastic lymphoma. *Leukemia* 2005;19:945–952.
  103. Kujawski LA, Longo WL, Williams EC, et al. A 5-drug regimen maximizing the dose of cyclophosphamide is effective therapy for adult Burkitt or Burkitt-like lymphomas. *Cancer Invest* 2007;25:87–93.
  104. Thomas DA, Faderl S, O'Brien S, et al. Chemoimmunotherapy with hyper-CVAD plus rituximab for the treatment of adult Burkitt and Burkitt-type lymphoma or acute lymphoblastic leukemia. *Cancer* 2006;106:1569–1580.
  105. Thomas DA, Kantarjian HM, Cortes J, et al. Long-term outcome after hyper-CVAD and rituximab chemoimmunotherapy for Burkitt (BL) or Burkitt-like (BLL) leukemia/lymphoma and mature b-cell acute lymphocytic leukemia (ALL) [abstract]. *Blood* 2008;112:Abstract 1929.
  106. Hoelzer D. 10th International Conference on Malignant Lymphoma: recent results in the treatment of Burkitt lymphomas [abstract]. *Ann Oncol* 2008;19(Suppl 4):iv83–84. Abstract 008.
  107. Dunleavy K, Little RF, Pittaluga S. 10th International Conference on Malignant Lymphoma: a prospective study of dose-adjusted (DA) EPOCH with rituximab in adults with newly diagnosed Burkitt lymphoma: a regimen with high efficacy and low toxicity [abstract]. *Ann Oncol* 2008;19:iv83–84. Abstract 009.
  108. Mead GM, Barrans SL, Qian W, et al. A prospective clinicopathologic study of dose-modified CODOX-M/IVAC in patients with sporadic Burkitt lymphoma defined using cytogenetic and immunophenotypic criteria (MRC/NCRI LY10 trial). *Blood* 2008;112:2248–2260.
  109. Le Gouill S, Lepretre S, Briere J, et al. Adult lymphoblastic lymphoma: a retrospective analysis of 92 patients under 61 years included in the LNH87/93 trials. *Leukemia* 2003;17:2220–2224.
  110. Aljurf M, Zaidi SZ. Chemotherapy and hematopoietic stem cell transplantation for adult T-cell lymphoblastic lymphoma: current status and controversies. *Biol Blood Marrow Transplant* 2005;11:739–754.
  111. Larson R, Dodge R, Burns C, et al. A five-drug remission induction regimen with intensive consolidation for adults with acute lymphoblastic leukemia: cancer and leukemia group B study 8811. *Blood* 1995;85:2025–2037.
  112. Hoelzer D, Gokbuget N, Digel W, et al. Outcome of adult patients with T-lymphoblastic lymphoma treated according to protocols for acute lymphoblastic leukemia. *Blood* 2002;99:4379–4385.
  113. Kantarjian HM, O'Brien S, Smith TL, et al. Results of treatment with hyper-CVAD, a dose-intensive regimen, in adult acute lymphocytic leukemia. *J Clin Oncol* 2000;18:547–561.
  114. Thomas DA, O'Brien S, Cortes J, et al. Outcome with the hyper-CVAD regimens in lymphoblastic lymphoma. *Blood* 2004;104:1624–1630.
  115. Dabaja BS, Ha CS, Thomas DA, et al. The role of local radiation therapy for mediastinal disease in adults with T-cell lymphoblastic lymphoma. *Cancer* 2002;94:2738–2744.
  116. Levine JE, Harris RE, Loberiza FR Jr, et al. A comparison of allogeneic and autologous bone marrow transplantation for lymphoblastic lymphoma. *Blood* 2003;101:2476–2482.
  117. Sweetenham JW, Santini G, Qian W, et al. High-dose therapy and autologous stem-cell transplantation versus conventional-dose consolidation/maintenance therapy as postremission therapy for adult patients with lymphoblastic lymphoma: results of a randomized trial of the European Group for Blood and Marrow Transplantation and the United Kingdom Lymphoma Group. *J Clin Oncol* 2001;19:2927–2936.
  118. Terwey TH, Massenkeil G, Tamm I, et al. Allogeneic SCT in refractory or relapsed adult ALL is effective without prior reinduction chemotherapy. *Bone Marrow Transplant* 2008;42:791–798.
  119. Levine AM, Seneviratne L, Espina BM, et al. Evolving characteristics of AIDS-related lymphoma. *Blood* 2000;96:4084–4090.

## Non-Hodgkin's Lymphoma

120. Mbulaiteye SM, Parkin DM, Rabkin CS. Epidemiology of AIDS-related malignancies: an international perspective. *Hematol Oncol Clin North Am* 2003;17:673–696.
121. Collaboration of Observational HIV Epidemiological Research Europe (COHERE) study group. Prognosis of HIV-associated non-Hodgkin lymphoma in patients starting combination antiretroviral therapy. *AIDS* 2009;23:2029–2037.
122. Boulanger E, Gerard L, Gabarre J, et al. Prognostic factors and outcome of human herpesvirus 8-associated primary effusion lymphoma in patients with AIDS. *J Clin Oncol* 2005;23:4372–4380.
123. Nador R, Cesarman E, Chadburn A, et al. Primary effusion lymphoma: a distinct clinicopathologic entity associated with the Kaposi's sarcoma-associated herpes virus. *Blood* 1996;88:645–656.
124. Delecluse HJ, Anagnostopoulos I, Dallenbach F, et al. Plasmablastic lymphomas of the oral cavity: a new entity associated with the human immunodeficiency virus infection. *Blood* 1997;89:1413–1420.
125. Mylona EE, Baraboutis IG, Lekakis LJ, et al. Multicentric Castleman's disease in HIV infection: a systematic review of the literature. *AIDS Rev* 2008;10:25–35.
126. Cheung MC, Pantanowitz L, Dezube BJ. AIDS-related malignancies: emerging challenges in the era of highly active antiretroviral therapy. *Oncologist* 2005;10:412–426.
127. Mounier N, Spina M, Gisselbrecht C. Modern management of non-Hodgkin lymphoma in HIV-infected patients. *Br J Haematol* 2007;136:685–698.
128. Mounier N, Spina M, Gabarre J, et al. AIDS-related non-Hodgkin lymphoma: final analysis of 485 patients treated with risk-adapted intensive chemotherapy. *Blood* 2006;107:3832–3840.
129. Ratner L, Lee J, Tang S, et al. Chemotherapy for human immunodeficiency virus-associated non-Hodgkin's lymphoma in combination with highly active antiretroviral therapy. *J Clin Oncol* 2001;19:2171–2178.
130. Sparano JA, Lee S, Chen MG, et al. Phase II trial of infusional cyclophosphamide, doxorubicin, and etoposide in patients with HIV-associated non-Hodgkin's lymphoma: an Eastern Cooperative Oncology Group trial (E1494). *J Clin Oncol* 2004;22:1491–1500.
131. Weiss R, Mitrou P, Arasteh K, et al. Acquired immunodeficiency syndrome-related lymphoma: simultaneous treatment with combined cyclophosphamide, doxorubicin, vincristine, and prednisone chemotherapy and highly active antiretroviral therapy is safe and improves survival—results of the German Multicenter Trial. *Cancer* 2006;106:1560–1568.
132. Little RF, Pittaluga S, Grant N, et al. Highly effective treatment of acquired immunodeficiency syndrome-related lymphoma with dose-adjusted EPOCH: impact of antiretroviral therapy suspension and tumor biology. *Blood* 2003;101:4653–4659.
133. Lim ST, Karim R, Nathwani BN, et al. AIDS-related Burkitt's lymphoma versus diffuse large-cell lymphoma in the pre-highly active antiretroviral therapy (HAART) and HAART eras: significant differences in survival with standard chemotherapy. *J Clin Oncol* 2005;23:4430–4438.
134. Wang ES, Straus DJ, Teruya-Feldstein J, et al. Intensive chemotherapy with cyclophosphamide, doxorubicin, high-dose methotrexate/ifosfamide, etoposide, and high-dose cytarabine (CODOX-M/IVAC) for human immunodeficiency virus-associated Burkitt lymphoma. *Cancer* 2003;98:1196–1205.
135. Kaplan LD, Lee JY, Ambinder RF, et al. Rituximab does not improve clinical outcome in a randomized phase 3 trial of CHOP with or without rituximab in patients with HIV-associated non-Hodgkin lymphoma: AIDS-Malignancies Consortium Trial 010. *Blood* 2005;106:1538–1543.
136. Boue F, Gabarre J, Gisselbrecht C, et al. Phase II trial of CHOP plus rituximab in patients with HIV-associated non-Hodgkin's lymphoma. *J Clin Oncol* 2006;24:4123–4128.
137. Ribera JM, Oriol A, Morgades M, et al. Safety and efficacy of cyclophosphamide, adriamycin, vincristine, prednisone and rituximab in patients with human immunodeficiency virus-associated diffuse large B-cell lymphoma: results of a phase II trial. *Br J Haematol* 2008;140:411–419.
138. Spina M, Jaeger U, Sparano JA, et al. Rituximab plus infusional cyclophosphamide, doxorubicin, and etoposide in HIV-associated non-Hodgkin lymphoma: pooled results from 3 phase 2 trials. *Blood* 2005;105:1891–1897.
139. Spina M, Simonelli C, Vaccher E, et al. Long-term follow-up of rituximab and infusional cyclophosphamide, doxorubicin, and etoposide (CDE) in combination with HAART in HIV-related non-Hodgkin's lymphomas (NHL) [abstract]. *Blood* 2008;112:Abstract 1467.
140. Dunleavy K, Little R, Wayne AS, et al. Long-term outcome of AIDS-related lymphoma treated with abbreviated cycles of EPOCH-RR: a prospective study of 40 patients [abstract]. *Blood* 2008;112:Abstract 3606.
141. Sparano JA, Lee JY, Kaplan LD, et al. Rituximab plus concurrent infusional EPOCH chemotherapy is highly effective in HIV-associated, B-cell non-Hodgkin's lymphoma. *Blood* 2009; in press.
142. Teruya-Feldstein J, Chiao E, Filippa DA, et al. CD20-negative large-cell lymphoma with plasmablastic features: a clinically heterogeneous spectrum in both HIV-positive and -negative patients. *Ann Oncol* 2004;15:1673–1679.

## Non-Hodgkin's Lymphoma

Individual Disclosures for the NCCN Non-Hodgkin's Lymphomas Panel						
Panel Member	Clinical Research Support	Advisory Boards, Speakers Bureau, Expert Witness, or Consultant	Patent, Equity, or Royalty	Other	Date Completed	
Jeremy S. Abramson, MD	None	None	None	None	11/13/09	
Ranjana H. Advani, MD	Allos	Allos	None	None	11/30/09	
C. Babis Andreadis, MD	None	None	None	Genentech, Inc.	9/28/09	
John C. Byrd, MD	None	None	None	None	1/7/10	
Myron S. Czuczman, MD	Biogen Idec; Celgene Corporation; Centocor, Inc.; Cephalon, Inc.; GlaxoSmithKline; and Novartis Pharmaceuticals Corporation	Abbott Laboratories; Amgen Inc.; Biogen Idec; Celgene Corporation; Cephalon, Inc.; Genentech, Inc.; GlaxoSmithKline; Millennium Pharmaceuticals, Inc.; and Novartis Pharmaceuticals Corporation	None	None	9/28/09	
Luis Fayad, MD	Eli Lilly and Company; Genentech, Inc.; GlaxoSmithKline; and Wyeth Pharmaceuticals	Cell Therapeutics, Inc.; Cephalon, Inc.; Eli Lilly and Company; Genentech, Inc.; and Wyeth Pharmaceuticals	None	None	12/17/09	
Andres Forero, MD	Biogen Idec; Daiichi-Sankyo Co.; Eli Lilly and Company; Genentech, Inc.; BioCryst; Immunomedics; and Seattle Genetics	None	None	None	9/28/09	
Martha J. Glenn, MD	None	None	None	None	12/16/09	
Jon P. Gockerman, MD	None	None	None	None	12/4/09	
Leo I. Gordon, MD	CureTech Ltd.; Genentech, Inc.; Millennium Pharmaceuticals, Inc.; and Pharmacyclis	CureTech Ltd.	None	CureTech Ltd.	7/21/09	
Nancy Lee Harris, MD	None	None	None	None	7/10/09	
Richard T. Hoppie, MD	None	None	None	None	7/22/09	
Steven M. Horwitz, MD	Genzyme Corporation; Medarex, Inc.; Merck & Co., Inc.; Allos; and Gloucester	Eisai Inc.; Genentech, Inc.; Merck & Co., Inc.; Allos; and Gloucester	None	None	11/13/09	
Mark S. Kaminski, MD	GlaxoSmithKline; Millennium Pharmaceuticals, Inc.; and Wyeth Pharmaceuticals	None	GlaxoSmithKline	None	1/22/10	
Youn H. Kim, MD	Merck & Co., Inc.; Allos; Gloucester; and Yaupon	Eisai Inc.; Merck & Co., Inc.; Gloucester; and Therakos, Inc.	None	None	11/23/09	
Ann S. LaCasse, MD	None	None	None	None	7/6/09	
Tariq I. Mughal, MD	Celgene Corporation; and Novartis Pharmaceuticals Corporation	Bristol-Myers Squibb Company; Celgene Corporation; and Novartis Pharmaceuticals Corporation	None	None	10/7/09	
Auayporn Nademane, MD	None	Allos Company	None	None	12/10/09	
Pierluigi Porcu, MD	None	Therakos, Inc.	None	None	7/13/09	
Oliver Press, MD, PhD	None	None	None	None	11/30/09	
Leonard Prosnitz, MD	None	None	None	None	9/29/09	
Nishitha Reddy, MD	None	None	None	None	1/11/10	
Mitchell R. Smith, MD, PhD	None	Celgene Corporation; Cephalon, Inc.; Genentech, Inc.; Millennium Pharmaceuticals, Inc.; and Wyeth Pharmaceuticals	None	None	12/16/09	
Lubomir Sokol, MD, PhD	None	Eisai Inc.; Allos; and Gloucester	None	None	12/1/09	
Lode J. Swinnen, MB, ChB	None	Abbott Laboratories; and Genentech, Inc.	None	None	12/18/09	
Julie M. Vose, MD	Applied Medical Resources Corporation; Bristol-Myers Squibb Company; Celgene Corporation; Genentech, Inc.; Genzyme Corporation; GlaxoSmithKline; Millennium Pharmaceuticals, Inc.; Novartis Pharmaceuticals Corporation; Allos Therapeutics; AnorMed, Inc.; Astellas; Rigel; and Pharmacyclis	None	None	None	12/18/09	
William G. Wierda, MD, PhD	Abbott Laboratories; Bayer HealthCare; Genitope; Genmab; Memgen; sanofi-aventis U.S.; and Sunesis Pharmaceuticals, Inc.	Celgene Corporation	None	None	12/7/09	
Joachim Yahalom, MD	None	None	None	None	11/20/09	
Furhan Yunus, MD	None	None	None	None	7/10/09	
Andrew D. Zelenetz, MD, PhD	Abbott Laboratories; Cephalon, Inc.; GlaxoSmithKline; Allos Pharm; Glouster Pharm; Roche; and Seattle Genetics	Bristol-Myers Squibb Company; Cephalon, Inc.; Eli Lilly and Company; Genentech, Inc.; GlaxoSmithKline; Allos; Cancer Genetics; and sanofi-aventis U.S.	None	None	12/21/09	

The NCCN guidelines staff have no conflicts to disclose.