



# NATIONAL DEFENSE RESEARCH INSTITUTE

THE ARTS

CHILD POLICY

CIVIL JUSTICE

EDUCATION

ENERGY AND ENVIRONMENT

HEALTH AND HEALTH CARE

INTERNATIONAL AFFAIRS

NATIONAL SECURITY

POPULATION AND AGING

PUBLIC SAFETY

SCIENCE AND TECHNOLOGY

SUBSTANCE ABUSE

TERRORISM AND  
HOMELAND SECURITY

TRANSPORTATION AND  
INFRASTRUCTURE

WORKFORCE AND WORKPLACE

This PDF document was made available from [www.rand.org](http://www.rand.org) as a public service of the RAND Corporation.

[Jump down to document](#) ▼

The RAND Corporation is a nonprofit research organization providing objective analysis and effective solutions that address the challenges facing the public and private sectors around the world.

## Support RAND

[Purchase this document](#)

[Browse Books & Publications](#)

[Make a charitable contribution](#)

## For More Information

Visit RAND at [www.rand.org](http://www.rand.org)

Explore [RAND National Defense  
Research Institute](#)

View [document details](#)

## Limited Electronic Distribution Rights

This document and trademark(s) contained herein are protected by law as indicated in a notice appearing later in this work. This electronic representation of RAND intellectual property is provided for non-commercial use only. Permission is required from RAND to reproduce, or reuse in another form, any of our research documents.

This product is part of the RAND Corporation monograph series. RAND monographs present major research findings that address the challenges facing the public and private sectors. All RAND monographs undergo rigorous peer review to ensure high standards for research quality and objectivity.

# Network-Centric Operations Case Study

The Stryker Brigade  
Combat Team

---

Daniel Gonzales, Michael Johnson, Jimmie McEver,  
Dennis Leedom, Gina Kingston, Michael Tseng

Prepared for the  
Office of Force Transformation in the Office of the Secretary of Defense  
Approved for public release; distribution unlimited



NATIONAL DEFENSE RESEARCH INSTITUTE

The research described in this report was prepared for the Office of the Secretary of Defense (OSD). The research was conducted in the RAND National Defense Research Institute, a federally funded research and development center supported by the OSD, the Joint Staff, the unified commands, and the defense agencies under Contract DASW01-01-C-0004.

**Library of Congress Cataloging-in-Publication Data**

Network-centric operations case study : the Stryker Brigade Combat Team /

Daniel Gonzales ... [et al.].

p. cm.

"MG-267-1."

Includes bibliographical references (p. ).

ISBN 0-8330-3846-X (pbk. : alk. paper)

1. Command and control systems—United States—Evaluation—Case studies.
  2. United States. Army. Stryker Brigade—Evaluation.
  3. Communications, Military—Evaluation—Case studies.
  4. Stryker brigade combat teams—Evaluation—Case studies.
  5. Deployment (Strategy)—Evaluation—Case studies.
- I. Gonzales, Daniel, 1956– II. Rand Corporation.

UA943.N47 2005

356'.16—dc22

2005022425

The RAND Corporation is a nonprofit research organization providing objective analysis and effective solutions that address the challenges facing the public and private sectors around the world. RAND's publications do not necessarily reflect the opinions of its research clients and sponsors.

**RAND**® is a registered trademark.

*Cleared for public release by Department of Defense Office of Freedom of Information and Security Review, 05-S-1626.*

© Copyright 2005 RAND Corporation

All rights reserved. No part of this book may be reproduced in any form by any electronic or mechanical means (including photocopying, recording, or information storage and retrieval) without permission in writing from RAND.

Published 2005 by the RAND Corporation

1776 Main Street, P.O. Box 2138, Santa Monica, CA 90407-2138

1200 South Hayes Street, Arlington, VA 22202-5050

201 North Craig Street, Suite 202, Pittsburgh, PA 15213-1516

RAND URL: <http://www.rand.org/>

To order RAND documents or to obtain additional information, contact

Distribution Services: Telephone: (310) 451-7002;

Fax: (310) 451-6915; Email: [order@rand.org](mailto:order@rand.org)

## Preface

---

This report summarizes the results of a case study on the Network-Centric Operations (NCO) capabilities of the Stryker brigade, a new U.S. Army medium-weight infantry brigade. It possesses a unique combination of organic reconnaissance, surveillance, intelligence and target acquisition capabilities, and digital battle command and communications systems. Perhaps most important, it utilizes a new organizational structure and a new information-centric concept of operations. We examine these aspects of the Stryker brigade and their implications for the force effectiveness and survivability of this unit.

This report should be of interest to U.S. Army and joint task force designers, those concerned with the development of digital battle command and communications systems, and those interested in the implications of NCO for the transformation of military forces.

This research was conducted for the Office of Force Transformation within the Acquisition and Technology Policy Center of the RAND National Defense Research Institute, a federally funded research and development center sponsored by the Office of the Secretary of Defense, the Joint Staff, the unified commands, and the defense agencies.

For more information on RAND's Acquisition and Technology Policy Center, contact the Director, Philip Antón. He can be reached by e-mail at [Philip\\_Antón@rand.org](mailto:Philip_Antón@rand.org); by phone at 310-393-0411, extension 7798; or by mail at RAND, 1776 Main Street, Santa

iv Network-Centric Operations Case Study: The Stryker Brigade Combat Team

Monica, California, 90407-2138. More information about RAND is available at [www.rand.org](http://www.rand.org).

# Contents

---

Preface.....	iii
Figures.....	ix
Tables.....	xi
Summary.....	xiii
Acknowledgments.....	xxvii
Abbreviations.....	xxix
<b>CHAPTER ONE</b>	
<b>Introduction.....</b>	<b>1</b>
Background.....	1
Data Collection and Study Reviews.....	4
Report Scope and Context.....	6
Assessment Measures.....	9
Report Outline.....	10
<b>CHAPTER TWO</b>	
<b>Stryker Brigade NCW Hypothesis.....</b>	<b>13</b>
Stryker Doctrinal Concepts.....	13
NCO CF.....	16
NCO Concepts.....	20
Stryker Brigade NCO Hypothesis.....	21
Summary.....	23

CHAPTER THREE

**Stryker Brigade MCP** ..... 25

MCP Overview ..... 25

Organization ..... 26

    Organizational Differences Between the SBCT and Light Infantry  
    Brigade ..... 27

Materiel ..... 30

Doctrine ..... 32

Training ..... 35

Leader Development ..... 36

SBCT Capabilities ..... 37

Summary ..... 39

CHAPTER FOUR

**Network and Battle Command Capabilities** ..... 41

Overview of the SBCT Communications Network ..... 41

SBCT TI ..... 42

SBCT Battalion and Above Network ..... 47

Limitations and Improvements to the SBCT Network ..... 52

Stryker Brigade Battle Command Systems ..... 53

Summary ..... 55

CHAPTER FIVE

**SBCT Scenario at JRTC** ..... 57

Enemy Situation ..... 57

Friendly Situation ..... 58

CHAPTER SIX

**Stryker Comparison to the Baseline** ..... 61

Networking ..... 62

    Network-Ready Nodes ..... 62

    Degree of Networking ..... 63

    Quality of Service ..... 64

    Network Reach in the Stryker Brigade ..... 65



Network Reach in the Light Infantry Brigade ..... 66  
 Quantitative Calculation of Reach..... 70  
 Comparison of Reach Metrics..... 74  
 Quality of Individual and Shared Information..... 74  
 Context and Caveats ..... 75  
     Primary Interview Results..... 76  
     Results in Terms of Information Position..... 78  
     Operational Evaluation Control Group (OECG) Interview Results ..... 79  
 Quality of Interactions and Collaboration..... 82  
 Quality of Shared Awareness and Understanding..... 87  
 Agile Decisionmaking and Self-Synchronization..... 93  
 Force Effectiveness ..... 98

**CHAPTER SEVEN**

**Conclusions**..... 101  
 Objective..... 102  
 Study Scope and Context ..... 102  
 Findings..... 104  
 Comparison of Exogenous Factors ..... 106  
 Caveats ..... 108  
 Proposed Enhancements to the NCO CF ..... 109  
 Implications for the Future..... 111

**APPENDIX**

**A. Director, Office of Force Transformation, Study Authorization Memorandum**..... 113  
**B. Glossary**..... 115  
**C. Complete List of Questions**..... 119  
 Bibliography..... 135



# Figures

---

5.1.	Stryker Brigade NCW MCP Overview.....	xiv
1.1.	Stryker Brigade NCW MCP Overview.....	3
2.1.	Stryker Brigade Operational Concept.....	14
2.2.	Stryker Brigade Operational Concept (Simplified).....	16
2.3.	NCO CF.....	17
2.4.	Stryker Brigade NCW Hypothesis.....	20
2.5.	Army High-Level Transformation Concept.....	23
3.1.	SBCT Organization.....	27
3.2.	SBCT RSTA Squadron.....	29
3.3.	SBCT, Light Infantry Brigade, and Augmenting Organizations at JRTC Exercises.....	30
3.4.	Stryker Family of Vehicles.....	31
3.5.	Command and Synchronization Options.....	34
3.6.	Stryker Brigade Combat Team Lines of Development.....	39
4.1.	Major Elements of the Stryker Brigade Network.....	43
4.2.	Typical Configuration of the SBCT TI.....	45
4.3.	SBCT Common Tactical Picture.....	46
4.4.	SBCT TOC-to-TOC C2 Node Subnet.....	48
4.5.	Typical Configuration of the SBCT Milstar-SMART-T Subnet.....	50
4.6.	SBCT Trojan Spirit Subnet.....	51
4.7.	ABCS Components.....	54
5.1.	Enemy Situation in Shughart-Gordon.....	58
5.2.	SBCT Concept of Operations.....	60

x Network-Centric Operations Case Study: The Stryker Brigade Combat Team

6.1.	Exploring the Reach of the Baseline Case .....	67
6.2.	Voice Net Structure Affects Reach: Examples.....	69
6.3.	Light Infantry Brigade Voice Networks.....	70
6.4.	Comparison of Reach Metrics for SBCT and Baseline .....	74
6.5.	Quality of Information—Interviews (I).....	76
6.6.	Quality of Information—Interviews (II).....	79
6.7.	Stryker Brigade and Baseline Information Positions.....	80
6.8.	Quality of Information—Operational Evaluation Surveys (I).....	81
6.9.	Quality of Information—Operational Evaluation Surveys (II).....	82
6.10.	SBCT Battle Rhythm .....	85
6.11.	Quality of Interactions—Operational Evaluation Surveys.....	88
6.12.	SBCT COP in MCS.....	89
6.13.	SBCT CIC.....	90
6.14.	Quality of Shared Awareness and Understanding—Operational Evaluation Surveys.....	92
6.15.	Speed of Command: SBCT Compared to the Baseline.....	93
6.16.	MCS Screen Shot: Day of Attack.....	96
6.17.	Better Decision Options.....	97
A.1.	Study Authorization Memorandum.....	114
C.1.	ABCS Information Completeness.....	122
C.2.	ABCS Information Timeliness.....	123
C.3.	ABCS Information Accuracy and Relevance .....	124
C.4.	ABCS Information Completeness.....	128
C.5.	ABCS Information Timeliness.....	129
C.6.	ABCS Information Accuracy and Relevance.....	130

# Tables

---

5.1. Comparison of NCO Capabilities and Unit Force Effectiveness.....	xxi
3.1. SBCT Personnel Breakdown .....	28
3.2. Stryker Vehicle Distribution .....	32
3.3. NCW and Army Terminology .....	33
4.1. Comparison of Networking and Battle Command Capabilities.....	56
6.1. Comparison of Network-Ready Node Metrics.....	63
6.2. Comparison of Degree of Networking Metrics.....	64
6.3. Reach Calculation for Light Infantry Brigade: Brigade Commander Down to Squad Member Level.....	73
6.4. SBCT Digital Overlays.....	91
7.1. Improved Mission Accomplishment and Survivability.....	105
B.1. Glossary of Terms.....	115



## Summary

---

The Stryker brigade is one of the newest units in the U.S. Army. Intrinsic to the design of this unit are digital communications networks and battle command systems, a new force design, and a medium-weight wheeled vehicle with unique speed and stealth characteristics. The Stryker brigade has several important new elements related to Network-Centric Operations (NCO), including its new operational concept, its organizational structure, and its networking capabilities. The Stryker brigade organizational structure is designed to gain and exploit an information advantage by conducting NCO. It utilizes an information-centric concept of operations with elements that bear a striking resemblance to some of the concepts found in NCO theory—as defined in the NCO Conceptual Framework (NCO CF) developed by the Office of Force Transformation (OFT) and Office of the Assistant Secretary of Defense for Networks and Information Integration (OASD [NII]).<sup>1</sup>

The Stryker Brigade Combat Team (SBCT) possesses an innovative organizational structure. It has an embedded reconnaissance, surveillance, and target acquisition (RSTA) squadron, an organic military intelligence company, and other features that make it capable of generating its own situational awareness data and quickly fusing

---

<sup>1</sup> The NCO CF is described in Signori et al. (2002); Evidence Based Research, Inc. (2003); and Signori et al. (2004). Major concepts of NCO are described in Alberts, Garstka, and Stein (1999) and Alberts and Garstka (2001).

this data to generate high-quality situational awareness information and understanding.

As illustrated in Figure S.1, these elements of the SBCT, doctrine, organization, materiel, training, and leader development, have been integrated by the Army to form what has been termed in the NCO literature to be a mission capability package (MCP) (Alberts, 1995). The concept of an MCP is discussed in detail later in this report. Here we point out that an MCP is more than a collection of warfighting capabilities. It includes the doctrine, organization, training, materiel, leadership, personnel, and facilities (DOTMLPF) elements, shown in Figure S.1, that are necessary to effectively employ the NCO capabilities potentially inherent in the digital networking and battle command systems also listed in the figure. Sometimes it is the nonmateriel elements of an MCP that are the most important.

**Figure S.1**  
**Stryker Brigade NCW MCP Overview**

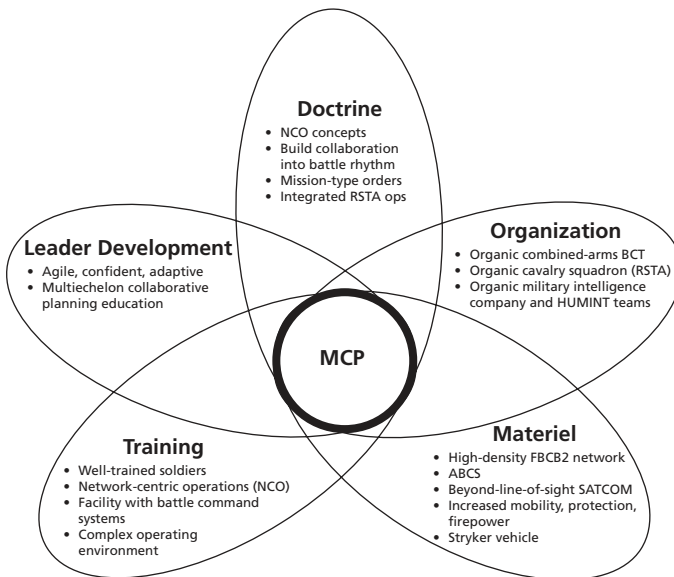



The SBCT is equipped with the current generation of Army digital terrestrial and satellite communications systems and evolving current battle command systems. These systems have limitations described later in this report.<sup>2</sup> In other words, the Stryker brigade network and battle command systems are far from perfect. Nevertheless, they can provide significantly more information if employed effectively, and, as we shall see later in this report, higher-quality information than that available to soldiers and commanders of analog, nondigitized units.

These same digital systems have been fielded in other digitized heavy armor units in the Army. In contrast, what is unique in the case of the Stryker brigade is that the organizational structure of the unit has been changed to leverage these new digital systems. These organizational changes are central to the MCP concept and are intended to improve the SBCT's ability to both rapidly generate and share information to develop shared situational awareness and understanding and to act decisively to exploit this increased situational awareness and understanding.

## Objective

The objective of this study is twofold: first, to understand the extent to which NCO capabilities are a source of combat power for the Stryker brigade and second, to determine the extent to which the tenets of the NCO hypothesis are realized by this new type of unit.

The original Network-Centric Warfare (NCW) hypothesis posits the following relationships between twenty-first century information technologies, information sharing, and warfighting capabilities:

- “A robustly networked force improves information sharing

---

<sup>2</sup> We only note here that the Army is addressing these limitations.

- Information sharing enhances the quality of information and shared situational awareness
- Shared situational awareness enables self-synchronization and enhances sustainability and speed of command
- These, in turn, dramatically increase mission effectiveness.” (Alberts and Garstka, 2001.)

The NCO CF developed by OFT and OASD (NII) provides a more detailed and precise elaboration of the NCW hypotheses.<sup>3</sup> It includes NCO measures and hypotheses for how these measures relate to and influence each other. The result is an interlinked set of NCO capabilities that, in combination, potentially can lead to improvements in overall military force effectiveness. Importantly, the NCO CF describes subsidiary metrics for assessing NCO capability measures, making it possible to determine whether and how possession of a particular NCO capability may relate to improvements in other NCO capabilities, and ultimately in force effectiveness.

## Study Scope and Context

The scope and context for this study are in part determined by the original strategic mission context defined for the Stryker brigade by the Army when the brigade was created several years ago.

We must provide early entry forces that can operate jointly, without access to fixed forward bases, but we still need the power to slug it out and win decisively. Today, our heavy forces are too heavy and our light forces lack staying power. We will address those mismatches. (Shinseki, 1999.)

---

<sup>3</sup> Please note, however, that NCW can be construed to apply only to warfighting operations, while NCO does apply to a broader array of operations that military forces can undertake, such as peacekeeping and stability and support operations. We use the terms NCO and NCW interchangeably in this report.

General Eric Shinseki, the former Army Chief of Staff, recognized the need for a new medium-weight brigade-size force capable of joint ground maneuver operations. His vision led to the creation of the Stryker brigade.

The Stryker brigade and the Stryker wheeled vehicle were designed to be rapidly deployable by airlift and sealift. These vehicles were designed to enable a light infantry force to maneuver rapidly on the battlefield to positions of tactical advantage.

In some quarters, the Stryker brigade is controversial. It is alleged this unit may not be well suited for certain operations and threat environments. Much of this controversy surrounds the Stryker combat vehicle, which is unique to this brigade in the U.S. Army. The focus of this study is not the vehicle and its capabilities or limitations. Rather it is on the information component or NCO capabilities of this unit that include the SBCT's RSTA capabilities, its networking and battle command systems, and its other information systems.

Critics of this new force design and this new vehicle have pointed out that the vehicle without advanced armor appliqué is vulnerable to medium-caliber weapons and rocket-propelled grenades (RPGs) that may be carried by insurgents and opposing infantry forces. These critics call into question the survivability of the Stryker vehicle against heavy armor opponents as well as enemy light infantry. It is not the purpose or intent of this study to address these issues concerning the survivability of the Stryker vehicle. Here, we wish only to point out that the Army is working to reduce the vulnerability of Stryker vehicles to medium-caliber weapons and RPGs by adding caging to the exterior of the vehicles to trap and detonate RPGs and by adding additional armor to the vehicles themselves. It is also important to point out that the SBCT was never designed to fight directly and alone against a heavy armor force for an extended period of time. It is designed for smaller-scale contingencies (SSCs) against smaller and lighter-weight opponents. In summary, our focus is not on the vehicles. Instead, in this analysis, we endeavor to take a

network-centric MCP approach and assess the unit's performance overall and not that of individual vehicles.

It is difficult to select a baseline unit to use as a comparison to the Stryker brigade because currently no nondigital medium-weight brigade exists within the U.S. Army. Therefore, one must choose as a baseline a light or a heavy armor brigade (either a U.S. brigade or one that is appropriately equipped from an allied nation). If one takes into account the strategic context for which the Stryker brigade was designed (rapid-deployment/rapid-response operations), then one can only choose a heavy armor brigade as the baseline if the heavy armor equipment were prepositioned afloat near the theater of operations.

Because this case study needs to be consistent with the original SBCT strategic mission context described above and because reliable unit performance data for both the Stryker brigade and a baseline unit in an SSC scenario was available only for unit rotations at the Joint Readiness Training Center (JRTC), we selected the closest predecessor unit to the SBCT to be a U.S. light infantry brigade (a unit that can be rapidly deployed to any theater of operations regardless of the location of the theater). Consequently, the baseline unit we compare the Stryker brigade to is a U.S. light infantry brigade in an SSC scenario that is used at the JRTC.<sup>4</sup> In addition, because we wish to understand the role and possible advantages NCO capabilities may have in ground warfare, we compare the Stryker brigade to a nondigitized light infantry unit.<sup>5</sup>

In summary, we compare the Stryker brigade to a nondigitized light infantry brigade and believe such a unit is the closest predecessor unit and best baseline for comparison because of the following reasons:

---

<sup>4</sup> Because of time and resource constraints, we did not do an exhaustive search for other suitable baseline units among the military forces of allied countries.

<sup>5</sup> Most, if not all, Army light infantry units are not digitized at the present time.

- The SBCT conducted a structured Certification Exercise (CERTEX) at JRTC. This provided us the best possible available data regarding the SBCT's use of NCO capabilities.
- We want to control for other factors, such as the type of scenario, the enemy composition, and the type of terrain, and therefore wanted to compare the SBCT vis-à-vis other units that conduct JRTC rotations—e.g., light infantry brigades.
- Both the SBCT and light infantry brigades train at SSC scenarios at the JRTC, and the SBCT is tailored for conducting operations in SSCs.
- The SBCT was originally designed to sometimes replace light infantry brigades in rapid deployment missions where greater mobility and firepower is necessary. Thus, we decided that comparing the SBCT to the organization it could replace (light infantry brigades) for some operations was best.
- The Marine Expeditionary Brigade has light infantry vehicles, but the organization, doctrine, training, and materiel factors are significantly different from those employed by the Stryker brigade.

The specific scenario we utilize as the point of comparison is one used at training rotations of light infantry brigade units at the JRTC for several years. In particular, we focus on the culminating tactical engagement such units execute at the JRTC during their operational evaluation, the brigade attack at the Shughart-Gordon urban training site.

It is important to note that the Stryker brigade JRTC scenario was more stressing in some respects for the Stryker brigade than has been typically encountered in the past at the JRTC by light infantry brigades. Like a light infantry brigade, the Stryker brigade was called on to rapidly deploy into contested territory, become combat ready quickly, rapidly maneuver once on the ground, and engage in offensive operations against an enemy light infantry force holding a key objective, the city of Shughart-Gordon. In contrast, unlike a light

infantry brigade, the Stryker brigade was tasked to execute additional simultaneous offensive, defensive, stability, and support operations in several other noncontiguous areas.

Because the focus of this report is on the NCO capabilities of the SBCT and not on the Stryker vehicle, we examine a broader range of measures of effectiveness. We of course consider overall force effectiveness and force survivability measures. In addition, we employ measures included in the NCO CF to measure the information component of the Stryker brigade. Some of the key NCO measures we employ are measures of networking capability, the quality of situational awareness information, quality of interactions and collaboration, speed of command, quality of decisions, and force synchronization.

## Findings

We examined the inference chains of the NCO hypothesis and the NCO CF from the context of Stryker brigade doctrine. Our investigation revealed that the Stryker brigade has been designed with NCO capabilities in mind and is an NCO-enabled MCP. Even though the Army does not express its doctrine in terms of NCO concepts, as described later in this report, Stryker brigade operational concepts and doctrine bear a close resemblance to the NCO concepts that have been under development and study in the Office of the Secretary of Defense (OSD).

We found that the Stryker brigade is a significantly more agile and capable combat force than its closest predecessor unit in similar operations at the JRTC.

Our analysis reveals that several key NCW factors contributed to an order-of-magnitude increase in the Stryker brigade's force effectiveness in the JRTC CERTEX.

The key NCO materiel improvements were:

- 75 percent or more of SBCT combat vehicles have networked battle command systems<sup>6</sup>
- High bandwidth beyond line of sight satellite communications (SATCOM) links are used to connect command and control (C2) centers at the brigade and battalion levels.

These NCO materiel improvements lead to significant NCO capability and force effectiveness improvements as shown in Table S.1.

These SBCT NCO capability enhancements include a significant improvement in shared situational awareness for soldiers in the SBCT compared to the quality of the situational awareness information typically available in a baseline unit. Another key result is acceleration in the speed of command (i.e., the time used to make key decisions by brigade commanders) that we measured to decrease from 24 hours (for a typical baseline unit) to three hours for the Stryker brigade.<sup>7</sup>

**Table S.1**  
**Comparison of NCO Capabilities and Unit Force Effectiveness**

	Light Infantry Brigade	Stryker Brigade
Quality of individual and shared information <sup>a</sup>	~10%	~80%
Speed of command	48 hours	3 hours
Ability to control the speed of command	No	Yes
Blue:Red Casualty Ratio	10:1	1:1

<sup>a</sup>"Quality of situational awareness information" is defined as the percentage of actual enemy, neutral, and friendly forces that are correctly identified and accurately located by the commanders and soldiers or by their information system in each unit.

<sup>6</sup> Note that the percentage of Stryker combat vehicles equipped with networked battle command systems in the fully equipped SBCTs is now higher than 75 percent.

<sup>7</sup> Speed-of-command estimates were determined by reconstructing the time line for key events and decisions from after-action reports, observer controller observations, and interviews with Stryker brigade commanders.

It is important to note that Stryker brigade doctrine is designed to exploit these NCW capabilities. The result for the Stryker brigade in its CERTEX was a significant improvement in force effectiveness and survivability in the culminating tactical engagement at the JRTC, as illustrated in Table S.1.

The following comments by JRTC observer controllers who witnessed the SBCT CERTEX corroborate our assertion that the SBCT's NCO capabilities made a significant contribution to the observed increase in force effectiveness.

The most impressive capability demonstrated by the SBCT was the ability to affect the enemy's decision cycle through [situational awareness/situational understanding] combined with mobility and lethality. The best example of this was during the Shughart-Gordon urban attack operation.<sup>8</sup>

The [situational awareness/situational understanding] afforded platoon leaders and commanders by the lower [Tactical Internet] and FBCB2 [gave them] the ability to maneuver their forces and close with and destroy the enemy during urban operations in Shughart-Gordon.<sup>9</sup>

Observing 24 units attack Shughart-Gordon as a JRTC [observer controller], I have never seen a unit clear every building and still retain combat power to defeat an enemy counter-attack.<sup>10</sup>

## Caveats

Some important caveats should be kept in mind that apply to these results. First, this case study considers one particular case. We consid-

---

<sup>8</sup> JRTC senior observer controller comments.

<sup>9</sup> JRTC senior observer controller comments. Note that FBCB2 means Force XXI Battle Command Brigade and Below.

<sup>10</sup> Observer in the Operational Evaluation Control Group.



ered one SBCT rotation at the JRTC and one tactical engagement, the attack at Shughart-Gordon that light infantry units have for years been trained on. Nevertheless, we believe this is a good “data point” because this JRTC vignette is carefully designed, is well instrumented, and was observed by experienced observer controllers. It demonstrates the potential of NCW capabilities in the Stryker brigade.

Second, many factors contributed to the success of the Stryker brigade in this case study, such as the Stryker vehicle’s mobility, which allowed the infantry soldiers to arrive fresh for battle instead of walking 25 kilometers while fighting enemy forces in ambushes in difficult terrain. The Stryker vehicle also provides more firepower than light infantry units typically have. However, it is not clear that this firepower was a dominant or even an important factor in the engagement. We do know the vehicle was used effectively as protection against enemy fire. It was not possible to attribute the observed increase in force effectiveness to a single variable—the capabilities of the information network or the capabilities of the Stryker combat vehicle. Thus, we attribute the significant improvement of overall unit force effectiveness to the entire MCP, as defined in Figure S.1. While it is not possible with the data available to isolate and quantify the contribution of the information component of the Stryker brigade to the overall force effectiveness of the SBCT, as discussed in detail later in this report, we believe the information component of the Stryker brigade to be essential to its overall success because changes in C2 processes, the new information-centric concept of operations, and the acceleration in the speed of command are key elements in how the Stryker fights and operates.

Finally, there is an additional caveat with regard to the data on which this report is based. In this particular case study, we had access to data from multiple and in some cases dissimilar sources for the different units whose performance we assessed. This study was also conducted under tight timelines to meet the sponsor’s needs, which prevented us from carefully designing data-collection strategies and

scheduling data-collection opportunities with specific units. Because of this, we had to make the best possible use of the data already available from recent exercises in which light infantry or Stryker brigades participated. In addition, because of this, we compiled interview data taken from independently conducted surveys of unit commanders for different exercises. We did not have control over the data-collection approaches used in these prior studies or operational evaluations. Nevertheless, we have made every effort to ensure that data collected from different exercises and dissimilar sources are used in a credible and analytically correct fashion.

## **Implications for the Future**

We have reason to believe that current results for the SBCT might underestimate the potential of more robust NCW capabilities in future land warfare. The current Stryker brigade information network is based on legacy communications systems that supply limited bandwidth and have limited range on the battlefield (many tactical Internet [TI] links are terrestrial line-of-sight links that have limited range, especially in complex terrain or high-foliage environments). The limitations of the current Stryker brigade TI were noted at the JRTC. An interim solution for these shortcomings has been found for the Stryker brigade currently deployed in Iraq. This unit is now equipped with 11 SATCOM very-small-aperture terminals (VSATs) to reduce the brigade's reliance on vulnerable ground-relay sites and to enable parts of the brigade to operate at greater distances from one another, consistent with Stryker brigade operational concepts.

However, this short-term solution should not cause neglect of important long-term initiatives that can provide even more robust NCO capabilities in the future. The Joint Tactical Radio System (JTRS) and the more capable and secure high-capacity SATCOM VSATs of the Warfighter Information Network–Tactical (WIN-T) program will significantly improve the networking and collaboration

capabilities of future digitized Army forces, including those of the Stryker brigade.

Another important area highlighted by SBCT units is training and personnel stabilization. Effective use of the current suite of applications in the Army Battle Command System (ABCS) requires well-trained, proficient soldiers and commanders. JRTC observer controllers estimate that a fully combat ready and cohesive Stryker brigade could achieve a 1:2 casualty ratio against the opposing force (OPFOR) at the JRTC in the same tactical engagement if SBCT soldiers were fully trained in all aspects of combined-arms warfare and with all aspects of ABCS.

Finally, the Stryker brigade may offer additional insight into what NCO capabilities can provide future U.S. Army, U.S. Marine Corps, and allied ground forces. The organizational structure of the Stryker brigade was designed around a new, information-centric operational concept. These new organizational and operational concepts may provide useful starting points for the operational concepts and organizational structures that will one day be used by Future Combat Systems (FCS)-equipped Army forces.



## Acknowledgments

---

We thank John Garstka, of the Office of Force Transformation (OFT), for making this research possible, helping to formulate this case study, and working to ensure OFT sponsorship for this research. The authors thank Colonel Richard Marchant and Colonel Gary Agron of the OFT for taking an active role in this research project. They were instrumental in opening the doors in the U.S. Army necessary to gain access to Stryker brigade data. This project would not have had success without their efforts. In addition, we thank Lieutenant General Edward Soriano, Commander, I Corps; Colonel Timothy Scully, Deputy Chief of Staff, I Corps; Colonel Carmichael, Director, TRADOC Brigade Coordination Cell; Colonel Brown, Commander, 1st Brigade, 25th Infantry Division (SBCT), Lieutenant Colonel McWherter, Deputy Commander, 1st Brigade, 25th Infantry Division (SBCT); and Lieutenant Colonel Steven Birch, Headquarters, Department of the Army, G-3, for their support.

This research has been advanced and improved thanks to the efforts of many individuals at Evidence Based Research, Inc. (EBR). EBR hosted many of the meetings and workshops at which this and other NCO case studies were reviewed, developed, and improved. EBR staff actively participated in these meetings and workshops. We would especially like to thank Richard Hayes, president of EBR, and Dave Signori of EBR for their contributions.

Finally, we thank Walt Perry and Bryan Hallmark of RAND for their careful reviews of this report and Sarah Harting for her expert assistance in the preparation of this manuscript.

## Abbreviations

---

ABCS	Army Battle Command System
AFATDS	Advanced Field Artillery Tactical Data System
AMDWS	Air and Missile Defense Workstation
ASAS	All-Source Analysis System
BCT	Brigade Combat Team
BSB	Brigade Support Battalion
BSN	Brigade Subscriber Node
C2	Command and control
C4ISR	Command, control, communications, computers, intelligence, surveillance, and reconnaissance
CCIR	Commander's Critical Information Requirements
CERTEX	Certification Exercise
CIC	Command Information Centers
CNR	Combat Net Radio
COE	Contemporary Operating Environment
COP	Common Operational Picture
CP	Command post
CSSCS	Combat Service Support Control System
DISE	Division Intelligence Support Element

DOTMLPF	Doctrine, organization, training, materiel, leadership, personnel, and facilities
DTSS	Digital Topographic Support System
EBR	Evidence Based Research, Inc.
EHF	Extremely high frequency
EPLRS	Enhanced Position Location Radio System
FASCOM	Field Artillery Support Command
FBCB2	Force XXI Battle Command: Brigade and Below System
FCS	Future Combat Systems
FM	Frequency modulation
GBS	Global Broadcast System
GCCS	Global Command and Control System
GPS	Global Positioning System
HUMINT	Human intelligence
ICV	Infantry combat vehicle
IMETS	Integrated Meteorological System
IPB	Intelligence preparation of the battlefield
ISR	Intelligence, surveillance, and reconnaissance
JCDB	Joint common database
JRTC	Joint Readiness Training Center
JTRS	Joint Tactical Radio System
LOS	Line of sight
MCP	Mission Capability Package
MCS	Maneuver Control System
MDMP	Military Decisionmaking Process
MI	Military intelligence



MILSATCOM	Military Satellite Communications
MOE	Measure of effectiveness
MOP	Measure of performance
MSE	Mobile Subscriber Equipment
MSTF	Modeling, Simulation, and Training Facility
NAI	Named Area of Interest
NBC	Nuclear, biological, and chemical
NCO	Network-Centric Operations
NCS	Network Control Station
NCW	Network-Centric Warfare
NTC	National Training Center
NTDR	Near-Term Digital Radio
O&O	Organizational and operational (concept)
OASD (NII)	Office of the Assistant Secretary of Defense for Networks and Information Integration
OECG	Operational Evaluation Control Group
OFT	Office of Force Transformation
OPFOR	Opposing force
OPORD	Operational order
OSD	Office of the Secretary of Defense
PIR	Priority Intelligence Request
RPG	Rocket-propelled grenade
RSTA	Reconnaissance, surveillance, and target acquisition
S2	Intelligence officer
SATCOM	Satellite communications
SBCT	Stryker Brigade Combat Team
SMART-T	Secure Mobile Antijam Reliable Tactical Terminal

SSC	Smaller-scale contingency
TAI	Target area of interest
TAIS	Tactical Air Information System
TI	Tactical Internet
TOC	Tactical operations center
TTP	Tactics, training, and programs
UA	Unit of action
UAV	Unmanned aerial vehicle
UHF	Ultrahigh frequency
VSAT	Very-small-aperture terminal
VTC	Videoteleconferencing
WAN	Wide-area network
WIN-T	Warfighter Information Network–Tactical

## Introduction

---

This report describes the findings of a RAND National Defense Research Institute (NDRI) case study designed to describe and assess the network-centric capabilities of the Stryker brigade. This research project was directed and sponsored by the Office of Force Transformation (OFT). It was conducted by RAND NDRI with assistance from Evidence Based Research, Inc., and with the full cooperation of the U.S. Army.<sup>1</sup>

## Background

The Stryker brigade is one of the newest units in the U.S. Army. Intrinsic to the design of this unit are advanced communications and battle management command and control (Army battle command) capabilities. Perhaps the most important new elements of the Stryker brigade are its new operational concept and organizational structure. It utilizes an information-centric concept of operations with elements that bear a striking resemblance to some of the concepts found in Network-Centric Operations (NCO) theory—as defined in the NCO Conceptual Framework (NCO CF) developed by the OFT and Office of the Assistant Secretary of Defense for Networks and

---

<sup>1</sup> See Appendix A for the study authorization memorandum signed by Vice Admiral Arthur K. Cebrowski, USN (Ret.), Director, OFT.

Information Integration (OASD [NII]).<sup>2</sup> The Stryker Brigade Combat Team's (SBCT's) organizational structure is innovative. It has an embedded Reconnaissance, Surveillance, and Target Acquisition (RSTA) squadron, an organic military intelligence company, and other capabilities to generate its own Blue situational awareness and to quickly fuse sensor data and reports to generate high-quality situational awareness of the enemy.

As illustrated in Figure 1.1, these elements of the SBCT have been developed, integrated, and co-evolved as a mission capability package (MCP).<sup>3</sup> The SBCT MCP concept is discussed in detail later in Chapter Three. Here we only wish to point out that an MCP is more than a collection of capabilities. It also includes the doctrine, organization, training, materiel, leadership, personnel, and facilities (DOTMLPF) elements shown in Figure S.1 that are necessary to effectively employ the NCO capabilities potentially inherent in the digital networking and battle command systems also listed in the figure. In other words, it is hypothesized that synergy will occur between the different elements of the MCP shown in the figure.

For example, the SBCT is equipped with current-generation Army digital terrestrial and satellite communications (SATCOM) systems, and the current generation of evolving Army battle command systems. These systems have been fielded in other digitized heavy armor units in the Army. The Stryker brigade organizational structure has been changed to accommodate these new digital systems.<sup>4</sup> These organizational changes are central to the SBCT MCP

---

<sup>2</sup> The NCO CF is described in Signori et al. (2002); Evidence Based Research, Inc. (2003); and Signori et al. (2004). Major concepts of NCO are described in Alberts, Garstka, and Stein (1999) and Alberts and Garstka (2001).

<sup>3</sup> In this report, we employ the term MCP as it has been defined in Alberts (1995) and Alberts and Hayes (2003).

<sup>4</sup> It is worth noting the current force brigade that is now fielded in 3rd Infantry Division (and the planned Future Combat Systems [FCS] unit of action [UA]) is now also being redesigned in similar ways.

**Figure 1.1**  
**Stryker Brigade NCW MCP Overview**

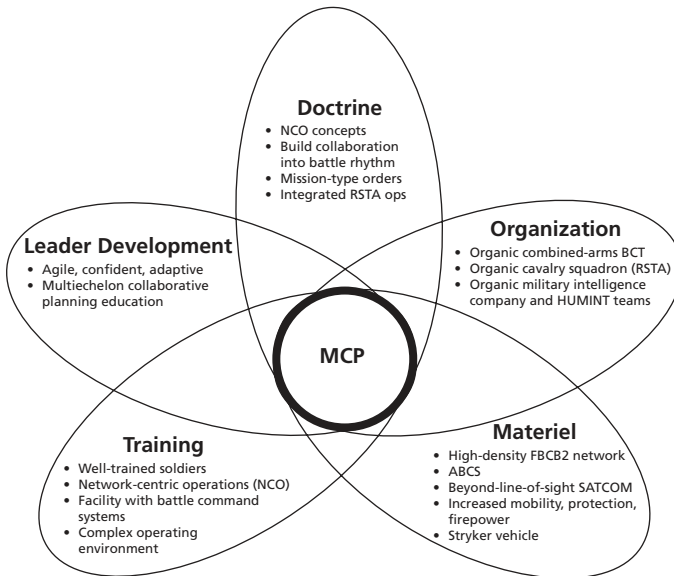

RAND MG267-1.1

concept and improve its ability to rapidly generate, share, and act on situational awareness information, even with the limitations that can be found in current SBCT communications and battle command systems. The methods of employment of SBCT communications and battle command systems have been tailored to “get the most out of these systems” and are based on new Army doctrine that emphasizes the importance and role of information in combat operations. Even though the Army does not express its doctrine in terms of standard NCO concepts, as we describe later in this report, Stryker brigade operational concepts and doctrine bear a close resemblance to NCO concepts found in the OFT and OASD (NII) NCO CF.

In some quarters, the Stryker brigade is viewed as a controversial unit that may not be well suited for certain operations and threat environments. Much of this controversy surrounds the medium-weight wheeled Stryker vehicle, which is employed by the Stryker

brigade. The focus of this report is not the vehicle and its capabilities or limitations, neither is the focus of this effort on the strategic deployability, weapons complement, or force structure of the Stryker brigade, although we have considered these factors in shaping our analysis. Rather it is on the network-centric capabilities this unit as a whole possesses that result from the RSTA capabilities, the communications and battle command systems, and the other supporting information systems employed by the soldiers and commanders in this unit. Consequently, we shall devote some space in this report describing these capabilities and how they are used by Stryker brigade warfighters to carry out the new operational concepts characteristic of the Stryker brigade. We also review the salient characteristics of these new operational concepts because these are of interest not only for how they apply to this particular type of unit but also because they may provide a preview of the operational concepts now under development for future Army forces that will be equipped with the Future Combat Systems (FCS). FCS—in particular its RSTA, communications, and battle command systems—should be much more capable than those available now in the Stryker brigade. Therefore, it is possible that the Stryker brigade can provide a glimpse of the capabilities Army FCS-equipped units and other international armies will have in the future.

### **Data Collection and Study Reviews**

Data collection and analysis were a major part of this case study as we examined SBCT performance at one Home Station exercise, one National Training Center (NTC) exercise, and one Joint Readiness Training Center (JRTC) exercise. With significant assistance from the Army, we collected a large amount of information on Stryker and light infantry brigades. To ensure we represented the capabilities of these Army units accurately and also that we have interpreted their operational concepts correctly, we briefed the results of the study to

key organizations within the Army. Further details on the analytical methodology employed in this study are given in Chapter Six.

In our data collection efforts, we focused on gathering descriptive and performance information for the Network-Centric Warfare (NCW) capabilities of the Stryker brigade. The Headquarters, Department of the Army, Deputy Chief of Staff for Operations (HQDA G-3), the Stryker brigades, and I Corps were instrumental in supplying the data needed to conduct this study and in reviewing this analysis for factual correctness. The organizations that have reviewed the study are listed below:

- Training and Doctrine Command (TRADOC) Brigade Coordination Cell
- I Corps
- 1/25 SBCT leadership
- Office of Force Transformation
- Director, RAND NDRI
- Director, RAND Arroyo Center
- OFT NCO Workshop #4
- Commander of the Operations Group, JRTC
- HQDA G-3, Deputy G-3
- Director, TRADOC Futures Center.

These project briefings were used to review the data collected in the study and to get second opinions on the key findings. The findings of the study were shaped and modified significantly as a result of these reviews. We shall spare the reader all of the interim steps we went through as part of this review process. We only point out here that all of the major findings in the study were reviewed by the organizations listed above and include their comments, caveats, and suggestions.

To conduct this study, we were granted access to unit performance and exercise information (Cody, 2003). As specified in the terms of reference governing data access to Stryker brigade information, we

briefed the results of this study to Major General Buford Blount, acting Deputy Chief of Staff for Operations, Headquarters, Department of the Army.

## Report Scope and Context

The scope and context for this report are in part determined by the original strategic mission context defined for the Stryker brigade by the Army when the brigade was created several years ago.

Shortly after the invasion of Kuwait in 1990, the 82nd Airborne Division was deployed to defend portions of Saudi Arabia. A frequent observation after the Gulf War was that this light infantry force was vulnerable to attack because it had limited tactical mobility in this early-entry role. The 82nd Airborne Division, even with the help of U.S. air power, would have suffered heavy losses to Iraqi heavy armor forces if Saddam Hussein had decided to press farther south into Saudi Arabia because the 82nd Airborne could not have readily maneuvered in the face of a larger Iraqi armored force (Matsumura et al., 2000; Gritton et al., 2000). The Stryker brigade concept largely grew out of this experience. In the words of General Shinseki:

We must provide early entry forces that can operate jointly, without access to fixed forward bases, but we still need the power to slug it out and win decisively. Today, our heavy forces are too heavy and our light forces lack staying power. We will address those mismatches. (Shinseki, 1999.)

The need for a new medium-weight force that would be capable of independent ground maneuver operations was recognized by General Shinseki, the former Army Chief of Staff. His vision led to the creation of the Stryker brigade.

The Stryker brigade and the Stryker wheeled vehicle were designed to be rapidly deployable by airlift aircraft as well as sealift ships. These vehicles were designed to enable light infantry forces to maneuver rapidly on the battlefield to positions of tactical advantage.



The Stryker brigade was also designed to take advantage of the new information technologies and networking capabilities being fielded to digitized ground forces at the time. This force design and vehicle concept led to the medium-weight force and the vehicle that lies at the core of the Stryker brigade. Consequently, the Stryker brigade was not designed to fight directly against a heavy armor force. In contrast, it is designed for smaller-scale contingencies (SSCs) against smaller and lighter-weight opponents.

This case study is consistent with the original strategic mission context of the Stryker brigade described above. This context implies that a predecessor unit for the SBCT is a light infantry brigade (a unit that can be rapidly deployed to the theater of operations). As discussed below, the baseline unit we compare the Stryker brigade to is a light infantry brigade in an SSC scenario.

In some rapid-response, rapid-deployment scenarios, a heavy armor force would not be deployed to the theater of operations in time to achieve U.S. objectives within the time scales desired by theater combatant commanders. In this particular case study, we believe it is appropriate to compare the Stryker brigade to a light infantry brigade in an SSC scenario context given the early phases of U.S. experience in Operation Desert Shield.<sup>5</sup> In addition, because we would like to understand the role and possible advantages NCO capabilities may have in ground warfare, we compare the Stryker brigade to a nondigitized light infantry unit (as it turns out, most if not all Army light infantry units are not digitized at present).

The specific scenario we use as the point of comparison is one that has been used at training rotations of light infantry brigade units at the JRTC for several years. In particular, we focus on the culminating tactical engagement that such units execute at the JRTC dur-

---

<sup>5</sup> We recognize that the Stryker brigade has greater mobility than a light infantry brigade. However, given that the rapid-response, rapid-deployment mission is foremost and common to both units (and only these units in the U.S. Army), we believe the light infantry brigade is the closest predecessor unit to the SBCT and the best baseline for comparison. See also Matsumura et al. (2000).

ing their operational evaluation—the brigade attack at the Shughart-Gordon urban training site at the JRTC.

We chose the attack on the village of Shughart-Gordon as our focus because good data were available from the JRTC for this particular tactical engagement and because this tactical engagement takes place at the end of the overall unit rotation (for both Stryker and light infantry brigades). By that time, these brigades have usually ironed out many of the technical equipment problems they experienced early in the rotation. By focusing on this tactical engagement, we believe we can get better data on the true combat capabilities of these units.

The larger operational context for the JRTC scenario and the Stryker brigade operational evaluation at the JRTC was a rapid-deployment, rapid-response operation. The SBCT is called on to rapidly deploy into contested territory, become combat ready quickly, maneuver quickly once on the ground, and then engage in offensive operations against an opposing light infantry force that holds a key objective—the city of Shughart-Gordon. At the same time, the Stryker brigade was tasked to execute additional simultaneous offensive, defensive, stability, and support operations in several other noncontiguous areas.

In summary, we compare the Stryker brigade to a nondigitized light infantry brigade and believe such a unit is the closest predecessor unit and best baseline for comparison for the following reasons:

- The SBCT conducted a structured certification exercise (CERTX) at JRTC. This provided us the best possible available data regarding the SBCT's use of NCO capabilities.
- We want to control for other factors, such as the type of scenario, the enemy composition, and the type of terrain, and therefore wanted to compare the SBCT vis-à-vis other units that conduct JRTC rotations—e.g., light infantry brigades.

- Both the SBCT and light infantry brigades train at SSC scenarios at the JRTC, and the SBCT is tailored for conducting operations in SSCs.
- The SBCT was originally designed to sometimes replace light infantry brigades in rapid-deployment missions where greater mobility and firepower is necessary. Thus, we decided that comparing the SBCT to the organization it could replace (light infantry brigade) for some operations was best.
- The Marine Expeditionary Brigade has light infantry vehicles, but the organization, doctrine, training and materiel factors are significantly different from those employed by the Stryker brigade.

## Assessment Measures

Finally, we point out one additional dimension to this case study. Because we are interested in NCO capabilities, we used the following measures of effectiveness (MOEs) to assess ground force NCO capabilities and ground force mission effectiveness. The MOEs we employ are mission accomplishment and the ratio of enemy to friendly force casualties.

The measures of command and control (C2) effectiveness we employ are quality of situational awareness information, quality of shared situational awareness information, speed of command, quality of decisions, and force synchronization. Please note that we employ the nomenclature of *NATO Code of Best Practice for C2 Assessment* and use the term “measures of C2 effectiveness” to mean metrics that measure the “impact of C2 systems within the operational context (e.g., time to develop a course of action, ability to provide information in required format, impact of information operations, and plan quality)” (NATO, 2002).

The measures of performance (MOPs) we employ are network capacity in kilobits per second and network reach (which is defined later in this report).

In a scientifically complete analysis of the problem at hand, all the MOEs and MOPs above would be linked together in a theoretical framework, and the linkages between these measures would be verified by experiment to confirm that improvements in networking MOPs and measures of C2 effectiveness also lead to improvements in combat outcomes (e.g., mission accomplishment) and combat effectiveness (e.g., friendly force survivability). Such a quantitative theoretical analysis is beyond the scope of this report for theoretical as well as practical reasons. However, some of the theoretical work for such analysis has been accomplished in recent work by OFT, OASD (NII), and by other researchers.<sup>6</sup> Much additional information and quantitative system and unit performance data would, however, be needed to apply these new methods. Such necessary quantitative data could not be captured or found during this study. Consequently, in this report, we will draw inferences from improvements in networking MOPs and measures of C2 effectiveness and such other factors as changes in doctrine and observed improvements in combat outcomes and combat effectiveness, but we will not demonstrate causal connections between them.

## Report Outline

This report is organized in the following way. In Chapter Two, we review some of the key concepts in the Stryker brigade and relate them to the key elements of the NCW hypothesis and the NCO CF. We provide a brief overview of the NCO CF.

---

<sup>6</sup> The NCO CF is described in Signori et al. (2002) and Evidence Based Research, Inc. (2003). Signori et al. (2004) provides the initial step toward such a theoretical framework. See also Perry, Signori, and Boon (2004).

In Chapter Three, we review the key elements of the Stryker brigade mission capability package. We review its organizational structure, its NCO materiel or system capabilities, and Stryker brigade doctrine, and then we touch on some other key aspects of the SBCT MCP, soldier training, and leader development.

In Chapter Four, we describe key aspects of the Stryker brigade communications network and its battle command systems. Chapter Five contains a description of the scenario for the tactical engagement at the Shughart-Gordon<sup>7</sup> urban training site at the JRTC. Chapter Six contains the results of our analysis. Here, we compare the performance of the Stryker brigade to that of a baseline unit in several key dimensions, using NCO capability metrics and measures for unit force effectiveness and survivability. We also describe the linkages between NCO capability improvements and improved unit mission effectiveness. Chapter Seven contains the conclusions of the report.

---

<sup>7</sup> Shughart-Gordon is named for Sergeant First Class Randall D. Shughart and Master Sergeant Gary L. Gordon, both of whom received the U.S. Medal of Honor posthumously for valor in Mogadishu, Somalia.



## **Stryker Brigade NCW Hypothesis**

---

One of the starting points for this investigation was an examination of the Stryker brigade organizational and operational (O&O) concept and the operational concept for the SBCT described therein (TRADOC, 2000). First we compare how Army doctrine and the Stryker brigade operational concept map onto NCO concepts to explore their similarities. This initial step of our analysis is purely derivative. We simply extract the key concepts found in the Stryker brigade O&O and interpret and translate them using the key concepts of the NCO CF developed by OFT and OASD (NII). Second, we briefly describe the OFT and OASD (NII) NCO CF, which is central to our analysis. We use this conceptual framework—specifically, the measures and metrics that it contains—for assessing the NCO capabilities exhibited by the SBCT during a stressing and structured training event at the JRTC.

### **Stryker Doctrinal Concepts**

The key elements or subsidiary concepts of the overarching Stryker brigade operational concept are illustrated in Figure 2.1.

The key major elements of the SBCT operational concept, shown in the ovals of Figure 2.1, are taken directly from or inferred from the Stryker Brigade O&O (TRADOC, 2000, Chapters Three,

**Figure 2.1**  
**Stryker Brigade Operational Concept**

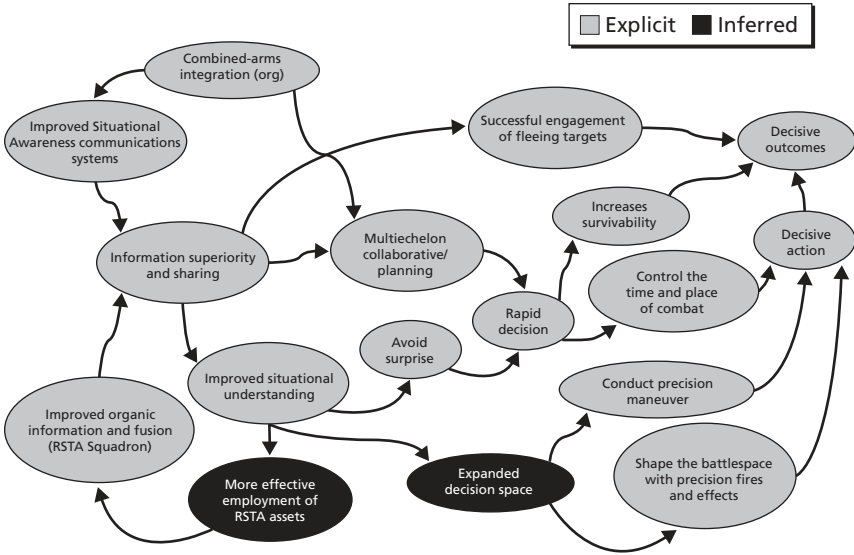

RAND MG267-2.1

Four, and Seven). The arrows linking these elements have been added to the figure by the authors of this report and indicate the major influences or causal relationships discussed in the Stryker Brigade O&O (TRADOC, 2000) that we identified in our review of the O&O.

Consequently, we believe Figure 2.1 shows the key capabilities that Stryker brigade doctrine developers envisioned to be needed by the SBCT to achieve decisive battlefield outcomes. The arrows between these concepts indicate the major (but certainly not all) influences between them, again as identified in the Stryker Brigade O&O. Figure 2.1 uses the Army terms of the Stryker Brigade O&O. The influences between these concepts are hypothesized in Stryker brigade doctrine to be positive but not always causal in nature. For example, “Improved SA and Communications Systems” may be necessary and sufficient to lead to “Information Superiority and Shar-



ing.” However, “Information Superiority and Sharing” may not necessarily always lead to “Improved Situational Understanding” because other factors, such as training (which is not shown in Figure 2.1), may be important in leading to “Improved Situational Understanding.” Indeed, it is the objective of this case study to understand the nature of the influences indicated in Figure 2.1.

The concepts labeled “explicit” in Figure 2.1 are concepts explicitly mentioned in the Stryker Brigade O&O. Those labeled “inferred” are discussed in general terms or are implied in the Stryker Brigade O&O but not mentioned explicitly in the document. For example, we have labeled one concept “Expanded Decision Space.” We elaborate on this concept below.

Key initial independent capabilities for the operational concept are improved situational awareness (battle command) and communication systems, more effective employment of RSTA capabilities, and improved organic information and fusion capabilities. At the very heart of the operational concept are multiechelon collaborative planning capabilities.

A simplified view of the Stryker brigade operational concept is shown in Figure 2.2. This figure shows the key major concepts envisioned by the creators of Stryker brigade doctrine to be needed by the SBCT to achieve decisive battlefield outcomes. As before, the arrows between concepts indicate how these concepts are believed to influence one another and reflect relationships identified in the Stryker Brigade O&O. In Figure 2.2, we have aggregated some of the subsidiary concepts found in the Stryker Brigade O&O into a small number of major or “larger” inclusive concepts. We have also shaded these subsidiary concepts to indicate the independent ones or initial drivers to the overall operational concept and to show which ones are dependent or intermediate in nature. We will map this simplified Stryker brigade operational concept to an operational concept based on NCO concepts.

**Figure 2.2**  
**Stryker Brigade Operational Concept (Simplified)**

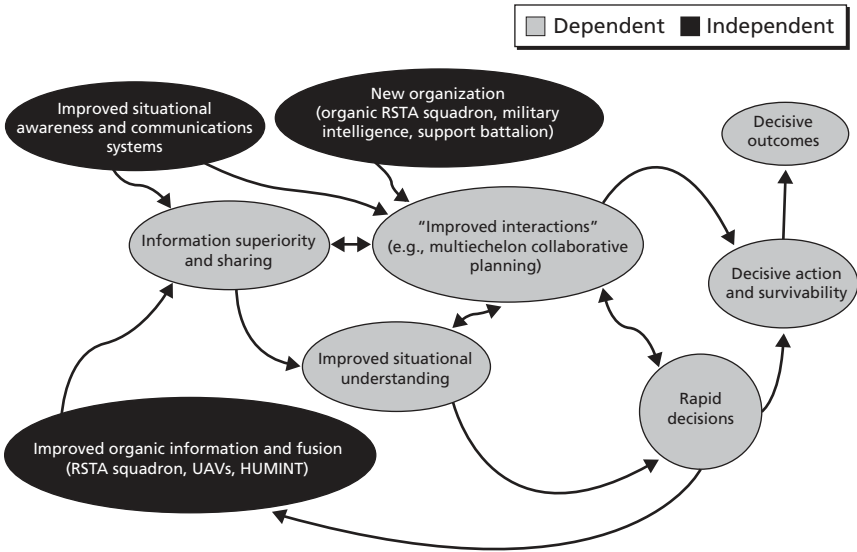

RAND MG267-2.2

## NCO CF

The NCO CF developed by OFT and OASD (NII), provides a more detailed and precise elaboration of the NCW hypotheses.<sup>1</sup> It includes NCO measures and hypotheses for how these measures relate to and influence each other. The result is an interlinked set of NCO concepts that describe how they in combination can lead to improvements in overall military effectiveness. Importantly, the NCO CF describes subsidiary metrics for assessing NCO capability measures, making it possible to determine whether and how possession of a

<sup>1</sup> Please note, however, that NCW can be construed to apply only to warfighting operations, whereas NCO applies to a broader array of operations that military forces can undertake, such as peacekeeping and stability and support operations. We use the terms NCO and NCW interchangeably in this report.

particular NCO capability might relate to improvements in force effectiveness.

Figure 2.3 illustrates the NCO CF.<sup>2</sup> It depicts key NCO capabilities or attributes and their relationships, influences, and feedback mechanisms. Figure 2.3 is intended to be read from the top down, although feedback mechanisms can occur in many directions between the concepts shown in the figure. The box at the top of the figure illustrates the key components of the force or military unit under consideration, in this case the Stryker brigade. This force contains an RSTA squadron with sensing capabilities to determine where adversaries may be located on the battlefield. It contains information-

**Figure 2.3**  
**NCO CF**

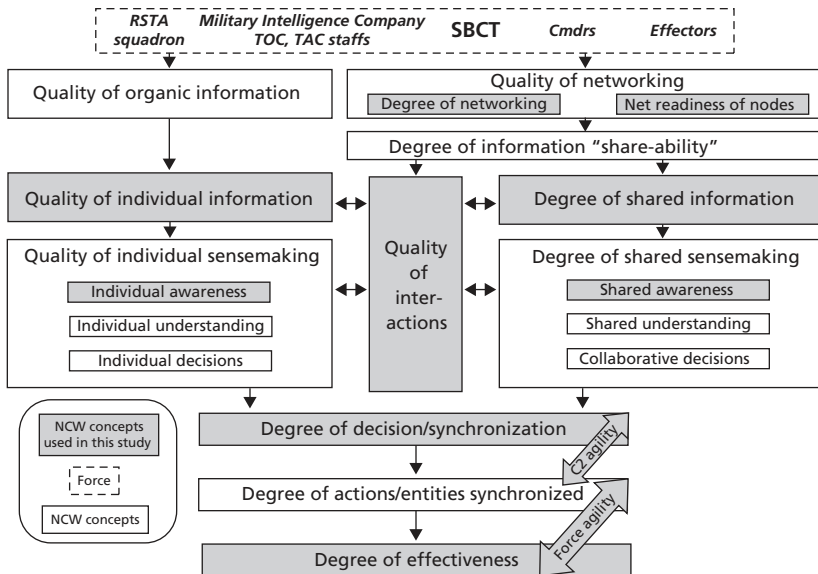

RAND MG267-2.3

<sup>2</sup> The NCO CF is described in Signori et al. (2002); Evidence Based Research, Inc. (2003); and Signori et al. (2004).

fusion capabilities in its military intelligence company and also within the staff organizations within its tactical operations centers (TOCs). It contains decisionmakers or commanders, and finally the SBCT also contains effectors, which can be weapon systems or other capabilities that can generate effects on the battlefield, or in the computers or minds of adversaries.

The other boxes below the SBCT box in Figure 2.3 indicate various NCO concepts. Definitions of these NCO concepts are provided in the glossary in Appendix B. The shaded boxes indicate NCO concepts that have been assessed either qualitatively or quantitatively in the analysis undertaken in the study. The NCO concepts not shaded are not explicitly addressed in this analysis, either because data was lacking to assess these measures or because of resource limitations associated with this report. Also not shown for reasons of simplicity are the domains in which many of these NCO concepts exist. For example, networking systems and network-ready nodes (the communication devices on weapons platforms and C2 nodes) exist in the physical domain. Information exists in the information domain (for example, the electronic memory of a computer system). Individual battlespace awareness and understanding exist in the cognitive domain of an individual warfighter or commander. Shared awareness and shared understanding exist in a social domain that consists of the shared cognitive domains of multiple warfighters.

We will not discuss the details of the NCO CF in this report. Several useful references are available that describe the details of the NCO CF (TRADOC, 2000). We only wish to point out here that NCO capabilities cross the physical, information, cognitive, and social domains. This should help dispel the misconception that NCO concepts involve only improved materiel or system solutions, such as high-capacity communications systems. An effectively integrated NCO-enabled MCP is a product not only of materiel enhancements that may include better communications networking systems but also related doctrine, organization, training, materiel, leadership, and personnel (DOTMLP) enhancements. All of these taken together, the

DOTMLP “package” is thought to be essential to realize the full potential of the NCO hypothesis. The MCP concept is linked to lines of development for DOTMLP. Both are closely tied to the overall NCO hypothesis.

Arrows between NCO concepts in the figure indicate a number of inferences or hypotheses. One inference is that the quality of networking can influence or improve the degree of information shareability. Another is that the quality of organic information (the information provided to an individual platform or soldier by that platform’s or soldier’s sensors) and the quality of networking can together improve the quality of individual information.

“Sense-making” is a term that describes the process of building or supplying awareness and understanding. This capability is closely tied to decisionmaking because individuals are reluctant to make decisions without a clear understanding of the situation. An important hypothesis captured by the NCO CF is that individual and shared sense-making are improved by the quality of interactions supported by the network. For example, such collaborative tools as videoteleconference capabilities, shared text chat applications, and voice teleconference lines can enhance the quality of interactions between individual soldiers and commanders. Such collaborative tools have been used within C2 centers and between strategic-, national-, and operational-level C2 centers. In the Stryker brigade, these types of collaborative tools have been used at the lowest tactical level.

The bottom section of Figure 2.3 illustrates several key hypotheses that connect improved NCO capabilities to improvements in overall fighting effectiveness. For example, in the NCO CF, the force or unit hypothetically can exploit improved sense-making and other NCW capabilities to improve decision synchronization, C2 agility, force synchronization, force agility, and ultimately mission effectiveness.

Each of these NCO concepts and measures and metrics for them are defined in the references describing the NCO CF.

## NCO Concepts

Figure 2.4 shows the Stryker brigade’s operational concept in terms of key NCO concepts. Where appropriate in many of the ovals shown in the figure, we have substituted for each Stryker brigade concept a corresponding NCO concept. Many of the NCO concepts shown in Figure 2.3 may be self-explanatory. These NCO concepts have been carefully defined in the OFT and OASD (NII) NCO CF.<sup>3</sup> Definitions for these NCO concepts can be found in the Glossary in Appendix B. Figure 2.3 is the “NCO version” of Figure 2.2. A close correlation exists between these key NCO concepts and the SBCT doctrine. Figure 2.4 provides a logical flowchart representation of the NCW hypothesis. The flowchart also shows nonlinear feedback mechanisms and potential multiplicative influences between NCO capabilities.

**Figure 2.4**  
Stryker Brigade NCW Hypothesis

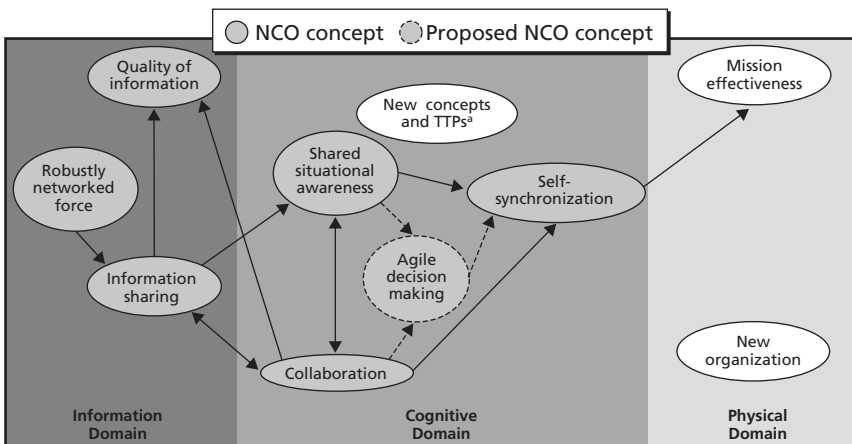

<sup>a</sup> TTPs are tactics, techniques, and procedures.

RAND MG267-2.4

<sup>3</sup> Major concepts of NCO are described in Alberts, Garstka, and Stein (1999) and Alberts et al. (2001).

The figure indicates that “Improved Interactions” lead not only to improved agile decisionmaking but also to improved individual and shared information and understanding. In other words, SBCT commanders and soldiers benefit from each other’s analysis by interacting on the network to achieve shared situational understanding.

We will look for evidence of these linkages when we compare the Stryker brigade to a baseline unit in this report.

## **Stryker Brigade NCO Hypothesis**

As mentioned above, the Stryker brigade MCP is designed to provide a synergistic combination of effects believed to increase this unit’s combat capabilities. The NCO hypothesis can be used to express the impact of these synergistic effects. Reviews of the Stryker brigade force design and its NCO capabilities have led us to modify or to tailor the NCO hypothesis for the Stryker brigade.<sup>4</sup> This specific Stryker brigade NCO hypothesis is given below.

The Stryker brigade’s organizational structure, battle command and networking capabilities, and evolving operational concepts should

- improve information quality, which in turn
- improves interactions and collaboration,
- improves shared awareness and understanding,
- provides the commander with better decision options,
- enables better control of speed of command, and
- together, these make the force more agile and better able to exploit other force capabilities to increase combat effectiveness.

---

<sup>4</sup> For the original NCO hypothesis, see Alberts, Garstka, and Stein (1999) and Alberts et al. (2001).

This tailored NCO hypothesis identifies key linkages between NCO concepts thought to enable the Stryker brigade to achieve an information advantage over an opponent and to translate this advantage into combat effectiveness. In this report, we shall examine key NCO concepts essential to this NCO hypothesis to determine how and to what extent they increase the combat effectiveness of the Stryker brigade.

Each organization is a product of its own culture and learning processes. The Army is no exception, and neither is the Office of the Secretary of Defense (OSD). The terminology and definitions associated with the NCO hypothesis are commonly used within OSD but are not yet used widely within the Army. It is important to note that the Army in Stryker brigade doctrine has developed a completely different set of terms and seemingly different concepts. In the next section, we examine and compare NCO concepts and Stryker brigade doctrinal concepts in more detail.

Before we leave the subject of Stryker brigade operational concept, it is important to note that the Stryker brigade operational concept is consistent with the Army high-level operational concept.

The key elements of the Army's high-level transformation concept are shown in Figure 2.5. These are the following: See First, Understand First, Act First, and Finish Decisively. These are also the key elements of the Stryker brigade operational concept. In Figure 2.5, we have mapped the high-level NCO concepts (one proposed NCO concept introduced earlier in the section and some other important elements we believe are important to highlight as they are components of the SBCT MCP) to the key elements of the Army's high-level transformation and Stryker brigade operational concept. This mapping illustrates the consistency between the Stryker brigade operational concept and the NCW tenets. In the next section, we define these key NCO concepts and show how they fit into an overall NCO CF (i.e., what their hypothesized relationships are). From this, the reader will be able to confirm that the NCO concepts in Figure



**Figure 2.5**  
**Army High-Level Transformation Concept**

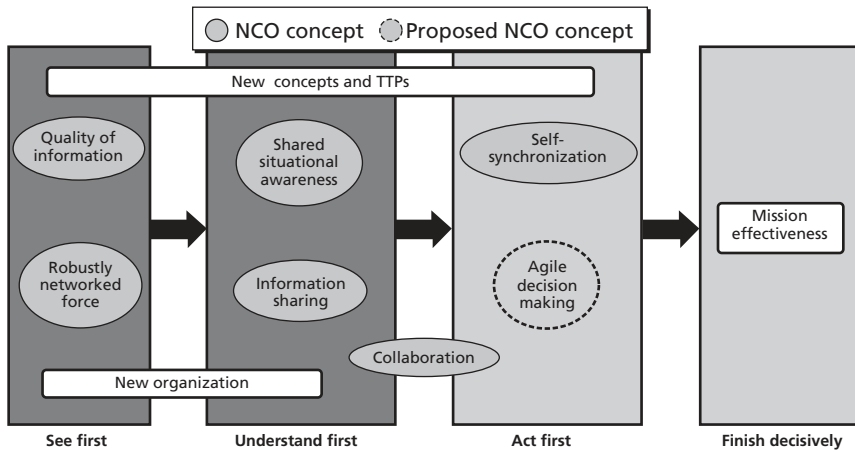

RAND MG267-2.5

2.4 have been placed into the proper elements of the Stryker brigade operational concept.

Later in this report when we examine Army Stryker brigade concepts and NCO concepts in more detail, we demonstrate that this Army simplified operational concept captures the essence of NCW.

## Summary

In summary, we found a close correspondence between key concepts in the Stryker brigade operational concept and key concepts of the NCO CF. We describe and use measures associated with these key NCO concepts later in this report.

The key NCO concepts we examine later in this report are

- quality of networking,
- quality of information (individual and shared),
- quality of interactions,

24 Network-Centric Operations Case Study: The Stryker Brigade Combat Team

- shared situational awareness (individual and shared),
- degree of decision and force synchronization,
- C2 agility, and
- degree of force effectiveness.

## **Stryker Brigade MCP**

---

In this chapter, we describe the key elements of the SBCT MCP. In addition, because it is useful in understanding some of the changes in the SBCT MCP, we also contrast the SBCT organization with that of a light infantry brigade.

### **MCP Overview**

Within the context of NCO, an MCP is the outcome of an improved technology insertion process that changes the way to organize, train, equip, and “fight” joint forces. It would “contain the concepts of operations, command and force structures, the corresponding doctrine, training and education, technology, and systems with a support infrastructure designed and tailored to accomplish specific missions” (Alberts, 1995). The constituents of an MCP are therefore more than a collection of capabilities designed to provide “the ability to execute a specific course of action.” In addition, the MCP, as defined in the NCO literature and as employed in this report, includes a coherent set of corresponding DOTMLPF changes necessary to exploit the full potential of new technology—i.e., materiel capabilities—and to achieve new desired capabilities.

The SBCT is innovative in many ways, but particularly in its organizational structure and operational concepts. These innovations were developed to enable the SBCT to generate information that

increases situational awareness of Blue forces, to quickly fuse sensor data and reports to generate high-quality situational awareness of the enemy, and to support enhanced understanding by commanders and soldiers.

The SBCT provides division, corps, or joint task force commanders a unique capability across the range of military operations and spectrum of conflict. Optimized for SSCs, the SBCT was intended to fill the capabilities gap between light and heavy forces by balancing lethality, mobility, and survivability against the requirements for rapid strategic deployability. Less well known, the SBCT design includes many elements of a robust NCW MCP.

The SBCT elements of doctrine, organization, materiel, training, and leader development have been integrated in the SBCT to form an MCP.

The SBCT achieves force effectiveness by exploiting the abilities of its skilled soldiers and capable leaders. In addition to the human dimensions, the enhanced tactical mobility afforded by the infantry carrier vehicle and the fidelity of the common operational picture provided by the technological advances in command, control, communications, computers, intelligence, surveillance, and reconnaissance, allow the SBCT commander to see friendly forces, see the enemy, see the terrain, conduct rapid effective decision-making, and bring effects and or forces to bear at identified decisive points. (U.S. Army, 2003.)

## Organization

The SBCT is an organic combined-arms team with approximate personnel strength of 3,500 soldiers. The SBCT has one organic RSTA squadron, three infantry battalions, one field artillery battalion, one brigade-support battalion, one antitank company, one engineer company, one military intelligence company, and one signal company, as shown in Figure 3.1.

**Figure 3.1**  
**SBCT Organization**

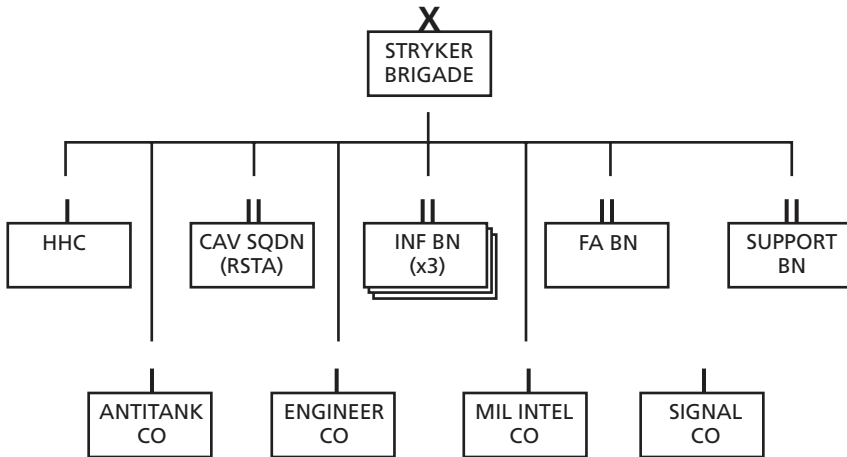

RAND MG267-3.1

The SBCT can accept augmentation from division or corps units to task-organize for specific missions, such as an aviation task force, air defense platoon, engineer battalion, military police company, psychological operations detachment, or civil affairs team. All organic units are mobile and included in the Stryker brigade network. Most are equipped with variants of the Stryker vehicle.

### **Organizational Differences Between the SBCT and Light Infantry Brigade**

The SBCT has 793 more “boots and eyes on the ground” and 360 more “trigger-pullers” than a light infantry brigade. A comparison of personnel in the SBCT and a light infantry brigade is shown in Table 3.1. This comparison shows that the percentage of rifleman and mortar-men in the two units are about the same (as a percentage of total authorized personnel for each unit). The SBCT does contain a still small but larger percentage of snipers than are present in the light infantry brigade.

**Table 3.1**  
**SBCT Personnel Breakdown**

	Light Brigade	Stryker Brigade
Total Authorized	2,705	3,498
Riflemen	1,062	1,353
Mortarmen	132	168
Snipers	18	51
Percentage of Total Authorized		
Riflemen	39%	39%
Mortarmen	5%	5%
Snipers	0.7%	1.5%

Overall, the SBCT has 29 percent more personnel than a light infantry brigade, although as shown in Table 3.1, each unit has a similar proportion of infantry (riflemen and mortarmen) personnel.

However, one area where the SBCT is significantly larger than a light infantry brigade is in reconnaissance capability. The SBCT has four times more reconnaissance platoons than the baseline light infantry brigade. Because the light infantry brigade has no brigade-level reconnaissance capability, it must assign the three battalion-level scout platoons to collect information to make brigade decisions. In addition to the three infantry battalion scout platoons, the SBCT has the brigade-level RSTA squadron shown in Figure 3.2.<sup>1</sup>

The RSTA squadron is intended to provide accurate and timely information over a large operating area. Unmanned aerial vehicles (UAVs) organic in the SBCT provide significant capability to gather additional intelligence, but intelligence, surveillance, and reconnaissance (ISR) in the SBCT relies on the human eyes of the reconnaissance platoons of the RSTA squadron. Furthermore, the human intelligence-trained soldier in every reconnaissance vehicle provides a significant capability to gain information from civilians in stability

<sup>1</sup> Note that unlike light infantry brigades, heavy brigades include a Brigade Reconnaissance Troop (BRT). While a BRT is typically smaller than the SBCT RSTA squadron and has less RSTA capability, it provides similar capabilities.

**Figure 3.2**  
**SBCT RSTA Squadron**

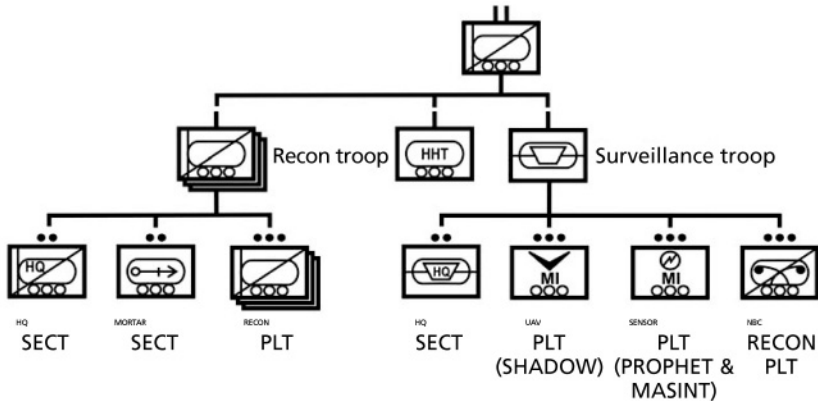

RAND MG267-3.2

and support operations. With current technology, intelligence collection in the tactical ground environment is far from a fully automated real-time process even when the best technical standoff ISR sensors can be brought to bear. Furthermore, intelligence collection in close tactical combat in the contemporary operating environment, where adversaries may include terrorists and insurgents who disguise themselves and hide among the local populace, the collection of human intelligence and experienced all-source intelligence analysis are essential to identify adversaries from civilian noncombatants. The SBCT MCP has these types of capabilities organically at the tactical level.

The organizational differences between the SBCT and light infantry brigade are shown in Figure 3.3. Many units are attached to a light infantry unit at the JRTC during exercises as direct support or operational control units because of the lean structure of current light infantry brigades. Reading from left to right and starting with these augmentation units are artillery, fire support, engineering, signal, air defense units, and long-range reconnaissance teams. In contrast, these types of units are all organic to the SBCT. Because of this, only

**Figure 3.3**  
**SBCT, Light Infantry Brigade, and Augmenting Organizations at JRTC**

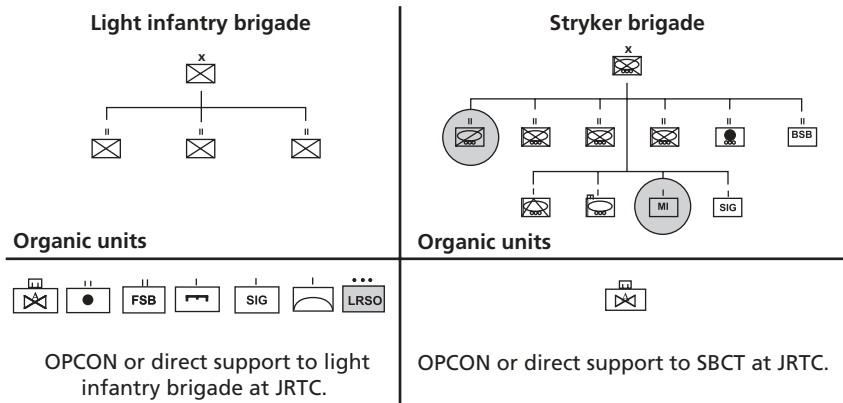

RAND MG267-3.3

aviation units typically have to be attached to SBCTs. Figure 3.3 also highlights the significantly larger RSTA and military intelligence analysis capabilities of the SBCT.

## Materiel

Three key materiel changes in the SBCT are the Stryker vehicle family, the SBCT digital communications network, and the Army Battle Command Systems (ABCS).

The Stryker family of vehicles provides the physical mobility to complement C2 agility. The wheeled vehicle is mounted on a Light Armored Vehicle III chassis with a high-hard steel structure that provides protection from small arms and artillery fire. The vehicle is fast and quiet, earning the Iraqi nickname “Ghost Soldiers” for the SBCT in Operation Iraqi Freedom. There are Stryker variants for infantry carriers; reconnaissance vehicles; mortar carriers; command vehicles;



**Figure 3.4**  
**Stryker Family of Vehicles**



**Stryker infantry carrier**



**Stryker mobile gun system**

RAND MG267-3.4

fire-support vehicles; engineer squads; medical evacuation; antitank; nuclear, biological, and chemical (NBC) reconnaissance; and a mobile gun system. The Stryker Infantry Carrier Vehicle shown in Figure 3.4 carries a nine-man squad in addition to the vehicle commander and driver. It is not a fighting vehicle, such as the M2 Bradley, but it does offer suppressive fire from the .50-caliber machine-gun and Mark 19 40-mm grenade launcher. The Stryker Mobile Gun System mounts a 105-mm cannon on the Stryker vehicle platform. It has recently been fielded in the Stryker brigades but was not in place at the time of the SBCT CERTEX at the JRTC that was the focus of this analysis. The distribution of Stryker vehicles by variant is shown in Table 3.2.

The Stryker brigade is equipped with a digital communications network that connects nearly every vehicle of the brigade into a single, relatively seamless network. The lower tactical Internet connects 75 percent or more of Stryker combat vehicles. The higher tactical Internet links brigade and battalion tactical operations centers, and other C2 centers, into a single high-capacity network. Further details on the Stryker brigade digital communications network and battle command systems are described in Chapter Four.

**Table 3.2**  
**Stryker Vehicle Distribution**

Infantry Carrier Vehicle (ICV)	108
Reconnaissance Vehicle (RV)	48
Mortar Carrier (MC)	36
Commander's Vehicle (CV)	39
Fire-Support Vehicle (FSV)	13
Engineer Squad Vehicle (ESV)	9
Medical Evacuation Vehicle (MEV)	17
Antitank Guided Missile Vehicle (ATGM)	9
NBC Reconnaissance Vehicle (NBC RV)	3
Mobile Gun System (MGS)	27

## Doctrine

The Army developed new operational concepts and doctrine to employ the SBCT that change the way the Army plans to fight. To conduct simultaneous offensive, defensive, and stability and support operations with the SBCT in significantly larger noncontiguous areas of operations, the Army intends to leverage advances in command, control, communications, computers, intelligence, surveillance, and reconnaissance (C4ISR) technology. In fact, a close correlation exists between Army operational concepts and the NCW attributes or concepts discussed previously in Chapter Two and shown in Table 3.3.

One important new concept is “See First, Understand First, Act First, and Finish Decisively.” This changes the conduct of an attack from “make contact, develop the situation, and maneuver reserves” to “make contact with ISR assets, develop the situation out of contact, maneuver combat forces to a position of advantage, and accept engagement on favorable terms.” Experience at both the JRTC and during Operation Iraqi Freedom shows the limitations of technical sensors to provide complete, accurate, and timely intelligence to support close combat in the contemporary operating environment. Stryker brigade doctrine emphasizes the use of the brigade RSTA squadron to “make contact with the enemy using ISR assets” to

**Table 3.3**  
**NCW and Army Terminology**

<b>NCW Terms</b>	<b>Army Terms</b>
MCP	Integrated SBCT DOTMLPF components
Organic information	Tactical information, spot reports
Network-enabled value-added services	ABCS, TI
Shared information	Information shared by staffs (internal TOC) and common operational picture (COP) across the network by units
Sense-making	Command and staff estimates, operations and intelligence summaries
Interactions	Multiechelon collaborative planning, battle updates, commander's huddle, targeting meeting
Individual and shared awareness	Situational awareness
Individual and shared understanding	Situational understanding
C2 agility	Agile and adaptive leaders, operate inside enemy's decision cycle
Force agility	Agility, tempo, rapid decisive operations

detect, observe, and develop the situation. The goal of this new doctrinal concept is to preserve the freedom of action for the infantry battalions, allowing them to bypass enemy forces in the disruption zone, maneuver to positions of advantage at the decisive point in the battle, and accept engagement on favorable terms.

Army doctrine in general and Stryker doctrine in particular have described multiple options for methods of command and for unit synchronization as shown in Figure 3.5.

Based on the situation, the commander may employ detailed orders that support centralized execution in accordance with a very specific scheme of maneuver and concept of support. Detailed plans that contain specific times and locations where units will engage in specific activities provide one method of synchronizing unit activities on the battlefield.

An alternative method of command utilizes mission-type orders and supports decentralized execution in accordance with the commander's intent, task, and purpose of subordinate units. Mission-type

**Figure 3.5**  
**Command and Synchronization Options**

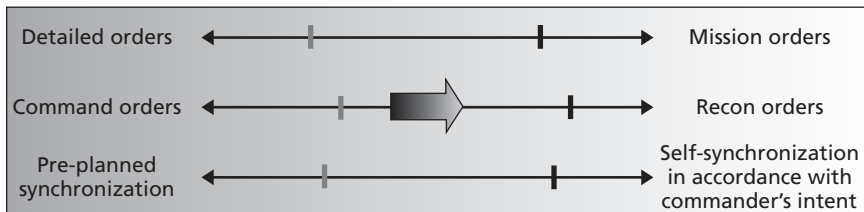

RAND MG267-3.5

orders provide clear descriptions of command intent and mission objectives and less detailed descriptions of the means to achieve those objectives. Thus, mission-type orders can typically be prepared more rapidly but may require more skill, more timely and more accurate knowledge of the battlespace, and greater collaboration between commanders so subordinate commanders can understand their implications correctly and to execute the orders effectively.

The concept of operations for a ground force operation can be described as “command-push” if the commander selects an avenue of approach before gaining full situational awareness of the battlefield. In such a circumstance, the commander will typically mass forces and effects to overwhelm whatever enemy forces are in the defense in the area of operation. The concept of operations can be described as “reconnaissance-pull” if the commander delays selection of the avenue of approach until his reconnaissance forces identify the gaps in the enemy defense that allow the force to maneuver and bypass enemy strength and attack from a position of advantage. The commander may either synchronize maneuver forces with combat support and service support in accordance with a preplanned synchronization matrix or permit subordinate units to self-synchronize their activities in accordance with the commander’s intent, as described above.

Stryker brigade doctrine encourages unit commanders to leverage NCW capabilities provided by new networking, collaboration, and battle command technologies to make more effective use of mis-

sion orders, reconnaissance pull operations, and self-synchronization to become more agile and effective. In other words, Stryker brigade doctrine falls much farther to the right in the doctrinal spectrum illustrated in Figure 3.5 than that typically employed in light infantry brigades equipped with analog systems.

## Training

One can argue that training is more important than ever in the Stryker brigade and in other digitized units because the networking and battle command systems employed are more complex than those used in analog-equipped light infantry brigades. If soldiers and commanders are not adequately trained on these NCW systems and are not proficient in their use in stressful battlefield conditions, then these NCW systems can be a hindrance rather than a help in combat. In this case, soldiers and commanders may abandon the NCW systems and resort to more familiar traditional “analog” methods—the use of voice radios to share situational awareness information and maps and grease pencils to attempt to establish and maintain a “common operational picture” of the battlespace. Indeed, a related NCO case study has highlighted the importance of training for NCO enabled units (PA Consulting Group, 2004). In this NCO case study the use of the Force XXI Battle Command: Brigade and Below (FBCB2) system by U.S. and UK forces in Operation Iraqi Freedom was examined. One of several findings of this case study was that UK soldiers received FBCB2 just a few weeks prior to crossing the Line of Departure in Iraq. Because they received little training on this new system, during the war UK soldiers and commanders abandoned the NCW systems and resorted to more familiar traditional analog methods.

Tactical Standard Operating Procedures of the first few SBCTs indicate the vital importance of training soldiers and leaders to operate on the network. These include the following sections on “net dis-

cipline” to establish and maintain the upper and lower Tactical Internets (TIs):

- Establish C2 and Communications Structure
- Graphical Icon Management and Naming Conventions
- FBCB2 Settings and Management
- Tactical Operations Center (TOC) Setup, Tear-Down, and Transfer of Network Control Station (NCS) Responsibilities
- Command Post Organization and Functions
- Battle Rhythm Update
- Maintaining the Commander’s Information Center
- Maintaining the Common Operational Picture (COP).

Training also covers how to plan and conduct combat operations to exploit the NCW capabilities in the SBCT. Stryker leaders train to use the ABCS and network capabilities to support multiechelon collaborative planning and synchronize combined-arms effects against the enemy. Indeed, NCW system training has become such a high priority for the first few SBCTs that a facility exclusively devoted to this purpose—the Stryker brigade Modeling, Simulation, and Training Facility (MSTF)—has been established at their home station at Fort Lewis, Washington, for this purpose.

## **Leader Development**

Leader development reflects the human dimension of transformation in the SBCT. The best ISR, networking, and battle command systems in the world can present a clear, accurate, timely, and relevant picture of the battlespace to the commander, but that commander must still make good tactical decisions that exploit the capabilities of subordinate units and take advantage of the terrain, enemy capabilities and limitations, and any other environmental aspects of the area of operations. To make good command decisions, the commander

must understand the implications of all these aspects of the battlespace. Achieving this level of understanding requires leaders who are well versed in all aspects of Stryker brigade doctrine, in the NCO concepts contained therein, and in the capabilities and limitations of the networking and battle command systems of the Stryker brigade.

One Stryker brigade commander believes this is essential to achieve mission success. He devotes training time and resources to back it up. He developed a new framework for leader development that builds on the old foundation of technical and tactical competence to develop agile, adaptive, and confident leaders by blending both analytical and creative ways of thinking and training.<sup>2</sup> A close correlation exists between these leader characteristics and such NCW attributes as risk propensity, competence, confidence, C2 agility, flexibility, adaptability, innovativeness, and responsiveness.<sup>3</sup>

## **SBCT Capabilities**

The Stryker brigade MCP includes the digital networking and battle command systems described in detail in Chapter Four and the corresponding developments in DOTMLPF described above. The Army describes the operational capabilities of the SBCT MCP this way:

The SBCT can be deployed rapidly and can be sustained by an austere support structure for up to 72 hours of independent operations. The SBCT conducts operations against conventional or unconventional enemy forces in all types of terrain and climate conditions and all spectrums of conflict (major theater war [MTW], smaller-scale contingency [SSC], and peacetime military engagement [PME]). During continuous operations, leaders

---

<sup>2</sup> Interview with SBCT commander. See also “Take Charge, Leaders Agility Book” (2003) for a detailed discussion of the SBCT leader development framework.

<sup>3</sup> See the glossary in Appendix B for definitions of these terms, and Signori et al. (2002); Evidence Based Research, Inc. (2003); and Signori et al. (2004) for a detailed description of these NCO concepts.

and soldiers must think faster, make decisions more rapidly, and act more quickly than the enemy. The SBCT can perform its mission throughout the entire spectrum of military operations (offensive, defensive, stability, and support) but may require some augmentation for certain missions. The SBCT may deploy as part of an early entry force and may fight by itself or as part of a division or corps. The SBCT's operational capabilities are

- Combined-arms assault in the close fight
- Mobility
- Reach
- Enhanced COP
- Lethality
- Force protection and survivability
- Joint, multinational, or interagency operability
- Full-spectrum flexibility and augmentation
- Simultaneous operations. (U.S. Army, 2003, pp. 1–4.)

The Stryker infantry battalions are the principal dismounted fighting force of the brigade. They may operate autonomously within the brigade area of operations and in close, complex, or urban terrain. The RSTA squadron may conduct continuous, all-weather, accurate, and timely reconnaissance of up to nine routes and eighteen areas. The artillery battalion provides accurate, long-range, proactive counterbattery fire support and can reinforce battalion mortars. The support battalion provides anticipatory, distributed, and reach logistical support and combat health service. The antitank company can destroy all types of enemy armor and many field fortifications. The military intelligence company provides analysis, integration, and reach intelligence support for linkage to division or Army forces. The engineer company provides maneuver and force support, countermobility, engineer reconnaissance, and topographical support. The signal company establishes and manages the C4ISR network, extends range of voice and data communications, and provides battlefield videoteleconference services.



## Summary

We can summarize the Stryker brigade MCP by using a representational device employed in other NCO case studies conducted for the OFT: DOTMLPF “lines of development.” These lines of development are illustrated in Figure 3.6. Along each line of development are some of the key factors or ingredients of the Stryker brigade MCP. Some of these key factors are NCO concepts or attributes. These are shown in boldface type in the figure. Others are key organizational differences between the SBCT and light infantry brigades: the addition of an organic RSTA squadron and military intelligence company.

**Figure 3.6**  
**Stryker Brigade Combat Team Lines of Development**

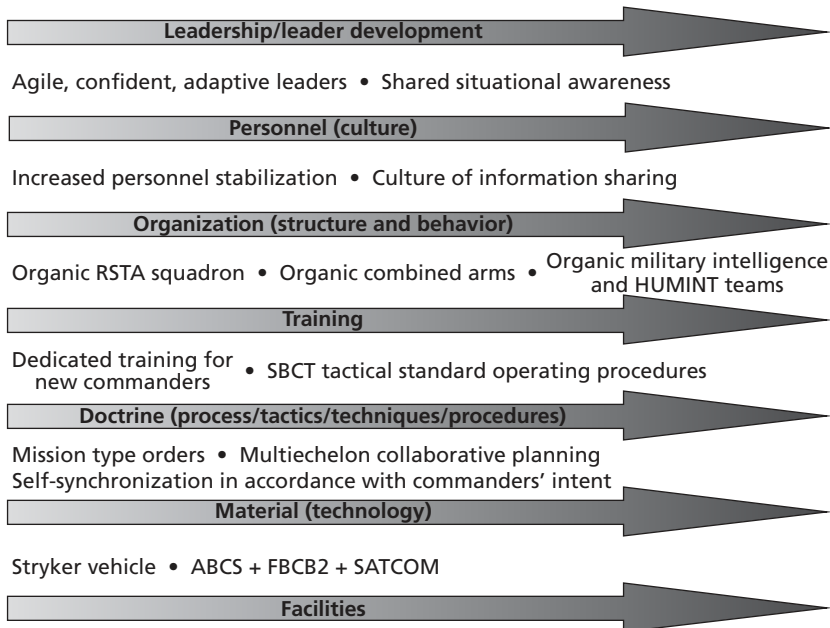



## Network and Battle Command Capabilities

---

The SBCT is equipped with the current generation of Army digital terrestrial and satellite communications systems and evolving current-generation battle command systems.

### Overview of the SBCT Communications Network

The SBCT communications network provides relatively low-bandwidth digital communication links to vehicles at the lowest tactical level and several high-capacity digital subnetworks. It connects the brigade's C2 centers and provides reach-back capabilities to higher headquarters. This heterogeneous digital network is illustrated in Figure 4.1. It provides the capability to share a picture of the battlespace with all participants on the network. Two key capabilities of the network are its ability to connect to higher-echelon units and organizations outside the brigade and connect its own constituents to each other and to the information assets available in the brigade.

The SBCT network consists of five subnetworks, or subnets: the SATCOM wide-area network (WAN), the TOC-to-TOC network, the TI, the Command Net Radio (CNR) network, and the Global Broadcast System (GBS).<sup>1</sup> Each subnet plays a role in connecting SBCT elements. The data rates for each subnet are shown in the fig-

---

<sup>1</sup> For simplicity, the GBS SATCOM and CNR networks do not appear in Figure 4.1.

ure. The SATCOM WAN is composed of Milstar extremely high-frequency (EHF) military satellite communications (MILSATCOM) point-to-point data links to Secure Mobile Antijam Reliable Tactical Terminals (SMART-Ts), ultrahigh-frequency (UHF) MILSATCOM data links to “Spitfire” MILSATCOM terminals fitted on command vehicles, and Trojan Spirit point-to-point data links that ride on commercial SATCOM systems as indicated in Figure 4.1. The Trojan Spirit system provides specialized communications equipment for reaching back to national-level intelligence assets and for transmitting UAV imagery and other intelligence data between tactical units.

The TI network is composed of Enhanced Position Location Reporting Radio Systems (EPLRS). EPLRS provides broadcast line-of-sight digital communications, as indicated by the broadcast “cloud” in Figure 4.1. The TOC-to-TOC network is composed of the Near-Term Digital Radio (NTDR) system operated in a multi-access broadcast communications mode. From the figure, the complex nature of the Stryker brigade communications network is evident. It is not a homogeneous network, and different subnets within the network have different capabilities and limitations. Later in this chapter, we will describe the capabilities and limitations of each of the SBCT communications subnets in detail.

## **SBCT TI**

The data-transmission component of the TI is the EPLRS network. EPLRS is a low-bandwidth (14.4 kps mean, 56.6 kps max), terrestrial network that carries situational awareness data and provides a text messaging capability throughout the SBCT. This network is based on terrestrial line-of-sight communication links. It provides digital communications to vehicles while on the move or when stopped.

In complex terrain and foliage, these line-of-sight links can have relatively short range. To extend the range of the TI, communications

**Figure 4.1**  
**Major Elements of the Stryker Brigade Network**

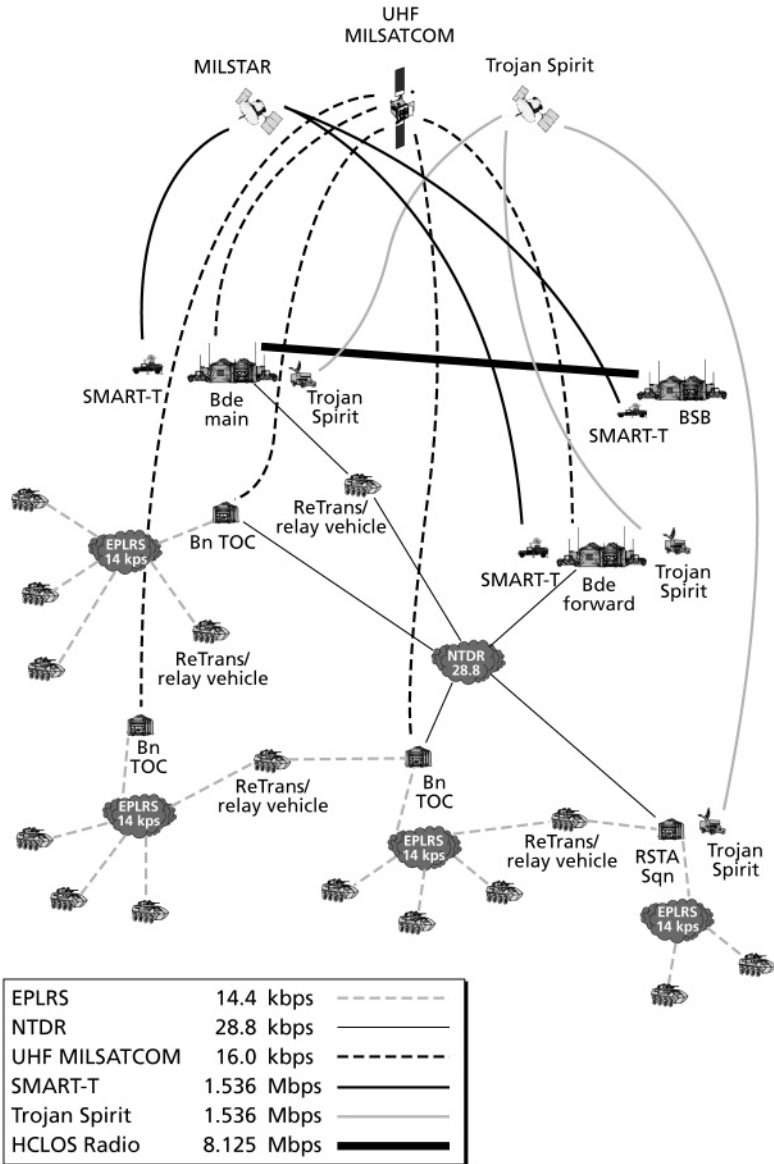

relay sites must typically be employed, as indicated in Figure 4.1. For example, at the SBCT JRTC CERTEX, TI relay sites were employed extensively. However, communication relay sites on the battlefield can have significant disadvantages. They are vulnerable to attack and once attacked the performance and reach of the network can be degraded significantly. At the Stryker brigade JRTC CERTEX, brigade signal company soldiers had difficulty locating relay sites in positions that could connect large numbers of Stryker vehicles effectively into the network. This difficulty was encountered because of the extensive foliage at Fort Polk, Louisiana, where the JRTC is located. In addition, the Opposing Force was able to locate several relay sites and successfully attack them, degrading the Stryker brigade communications network.

The voice component of the TI is the CNR. CNR is a voice-only network utilizing frequency modulation (FM) voice Single-Channel Ground and Airborne Radio System man-portable radios. CNR systems have many of the same limitations as the EPLRS mentioned above. In particular, communication relay sites are also required for CNR. CNR is organized into hierarchically structured subnetworks that mirror the organizational structure of the SBCT. Subnets exist at the squad, platoon, company, battalion, and brigade levels.

The TI is illustrated in Figure 4.2. It is subdivided into series of the EPLRS subnets that consist of all Stryker vehicles within line of sight of another. If one EPLRS network participant in one of the subnets wants to send a message to another EPLRS network participant in another subnet, that message must be sent through an intermediate node or gateway. Those intermediate nodes are indicated notionally in the figure at the intersection of two or more adjoining circles. That said, the network structure is dynamically reconfigurable, able to adapt as equipped vehicles move in and out of line-of-sight range of one another and as users request (as needed) direct linkages to each other. Further, while messaging activity must deal

**Figure 4.2**  
**Typical Configuration of the SBCT TI**

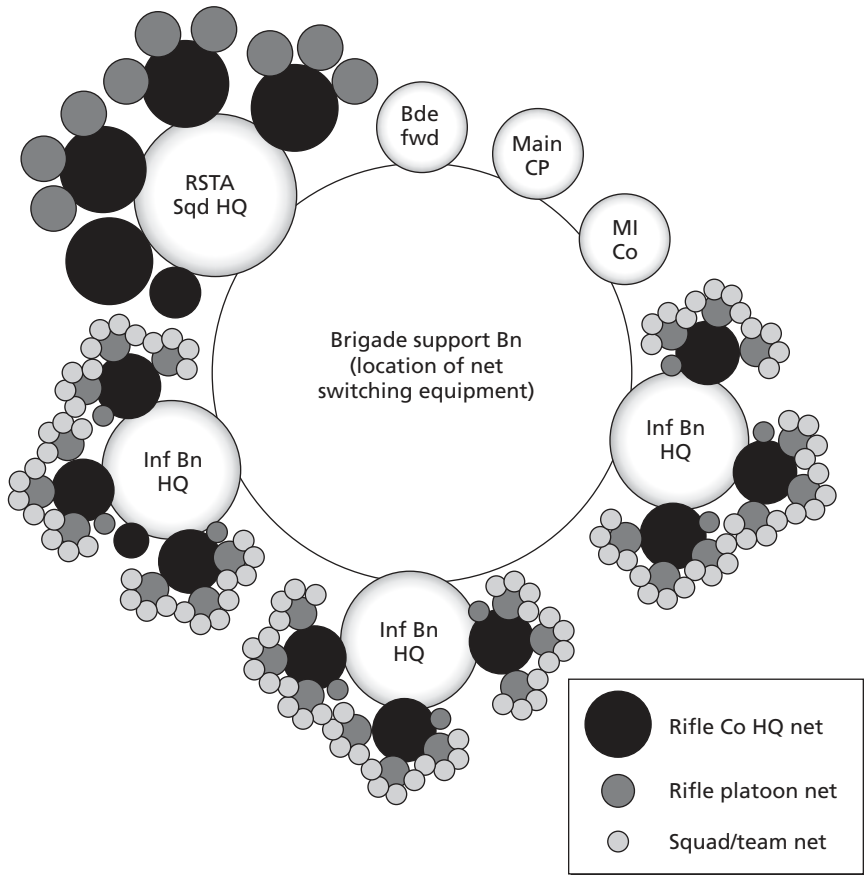

RAND MG267-4.2

with the network structure indicated in Figure 4.2, that structure is transparent to the user with regard to the automatic generation and receipt of EPLRS data.

EPLRS allows for the automatic generation and distribution of unit, vehicle, and personnel location information from and to all

EPLRS-equipped vehicles in the SBCT. This information, as well as access to the EPLRS text and data messaging capacity, is accessed by the soldier via the FBCB2 system. An FBCB2 situational awareness display screen is shown in Figure 4.3. Locations of vehicles from two different SBCT units are displayed using two different shades of gray (light and dark in this case). If location and identity information are available on enemy forces or vehicles, this Red situational awareness data can be displayed on the same screen using Red icons. In the case of Figure 4.3, no Red units or vehicles are shown.

FBCB2/EPLRS is present on all Stryker command vehicles down to the platoon level in the brigade; within a four Infantry Carrier Vehicle (ICV) platoon, two to four of the ICVs are equipped with FBCB2/EPLRS.

Note that, when two ICVs in each platoon are not equipped with EPLRS/FBCB2, these two ICVs are assigned as wingmen to

**Figure 4.3**  
**SBCT Common Tactical Picture**

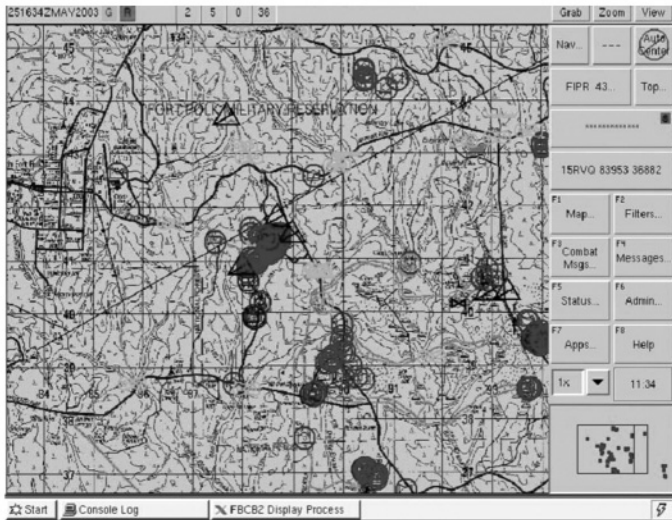



those who are. When the first Stryker brigade was initially fielded, not all Stryker vehicles were equipped with FBCB2. Thus, the above concept of operations was developed to share situational awareness information with every combat vehicle in the brigade. According to this doctrine, the lead ICV passes relevant situational awareness about maneuver and other platoon operations to its wingman via CNR; likewise, because the wingman is to stay with its lead ICV, echelons above platoon maintain good situational awareness about the wingman vehicle—it is with its lead vehicle, which is accounted for in the situational awareness data on the TI.

EPLRS has automatic relay and dynamic reconfiguration capabilities, leading to a robust network structure for situational awareness data. However, as mentioned above, line of sight, range, and bandwidth constraints, particularly in complex terrain, can lead to less reliable C2 messaging and data (e.g., overlays) transmission.

Despite these limitations, the FBCB2/EPLRS system provides rich and reliable connectivity throughout the SBCT, even when operating in geographically distributed configurations. Moreover, these systems provide the SBCT warfighter with valuable information storage and visualization capabilities that are simply not present with CNR alone. As a result, CNR, the voice component of the TI, is freed up from situational awareness traffic and can be used for collaboration, synchronization, and the transmission of information not well suited for FBCB2/EPLRS.

## **SBCT Battalion and Above Network**

The Stryker brigade communications network at battalion and above consists of three major subnets: a SATCOM WAN, a TOC-to-TOC C2 node line-of-sight terrestrial communications network, and GBS.

The C2 node subnet is illustrated in Figure 4.4. It is predominantly a low-bandwidth (28.8 kps) terrestrial data communications

**Figure 4.4**  
**SBCT TOC-to-TOC C2 Node Subnet**

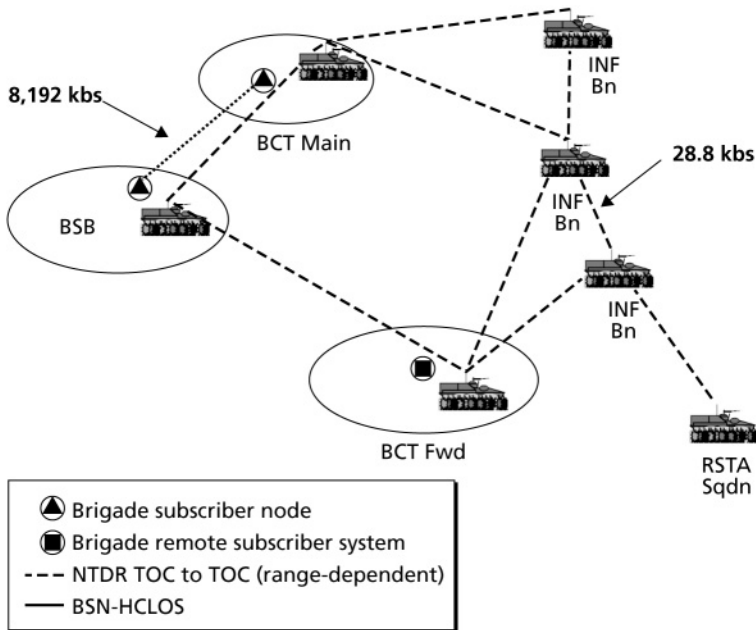

RAND MG267-4.4

network, based on the NTDR system, connecting SBCT brigade-level TOCs, the RSTA squadron command post, the brigade support battalion (BSB) TOC, and infantry battalions TOCs with each other. A special high-capacity link in this subnet connects the main brigade TOC with the BSB TOC using Brigade Subscriber Node (BSN) equipment and High-Capacity Line-of-Sight radios equipped with directional antennas. This network is used for distributing commander’s guidance and orders, sharing planning and intelligence data, and exchanging digital overlays for use in ABCS systems.

The NTDR system used in the Stryker brigade can be used in a multiaccess network configuration or in a point-to-point line-of-sight configuration. In the latter configuration, this radio can provide up to

8 Mbps communications links. However, it was our experience, based on the Stryker brigade CERTEX at JRTC and other home station exercises we observed, that the NTDR is typically used in the multi-access mode using omnidirectional whip antennas. In this mode, this radio typically provides 28.8 kbps links. If employed in a multiaccess mode, more than a dozen NTDR-equipped command posts and vehicles can join a single, multiaccess subnet if they are in line of sight of one another. Some command vehicles in the SBCT are equipped with NTDRs, for example the brigade commander's vehicle. This provides SBCT commanders real-time access to both the TI (via EPLRS or as explained below via UHF MILSATCOM) and to the battalion and above network (via NTDR).

The SBCT satellite-based WAN is based on multiple satellite systems. High-bandwidth jam-resistant communication links are supplied by the Milstar satellite constellation and by SMART-Ts. This part of the SBCT SATCOM WAN is illustrated in Figure 4.5. SMART-Ts connect the SBCT to echelons above brigade and also connect brigade C2 nodes.

The Milstar WAN is a high-bandwidth data network (1.5 Mps), which utilizes the Medium Data Rate (MDR) package on Milstar satellites. SMART-Ts, which are essential to link with the Milstar MDR, are typically available in the SBCT at the main command post, the forward command post, and the BSB. Milstar links provide the most survivable and jam-resistant portion of the Stryker brigade communications network.

It is important to note that the SBCT is equipped with only three SMART-Ts, so not all battalions in the SBCT can be connected by Milstar links. The Milstar network can be dynamically reconfigured by moving a SMART-T from one battalion to another in the SBCT. For example, an infantry battalion in the main effort may be equipped with a SMART-T at key points in a battle.

The SBCT Trojan Spirit subnet is illustrated in Figure 4.6. The Trojan Spirit SATCOM system connects the brigade with higher

**Figure 4.5**  
**Typical Configuration of the SBCT Milstar-SMART-T Subnet**

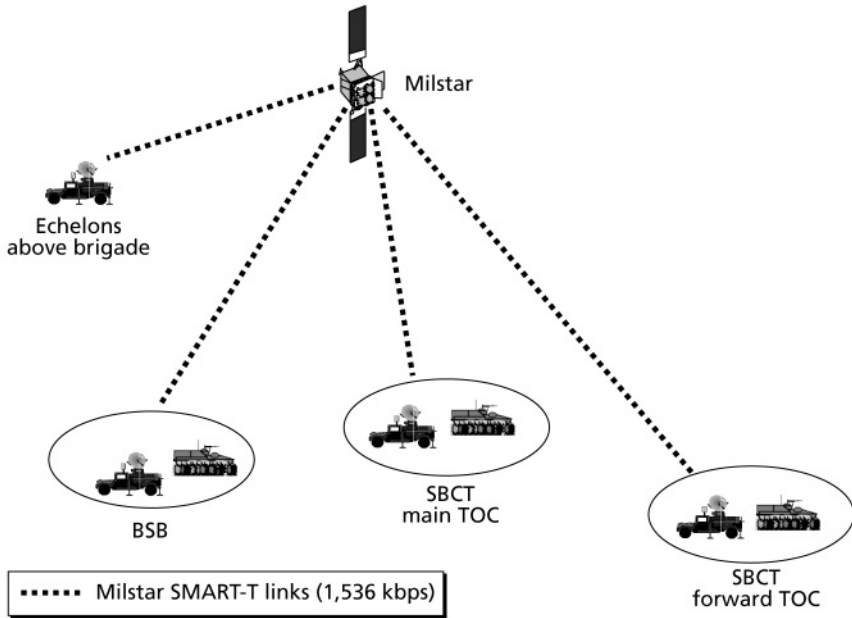

RAND MG267-4.5

headquarters and also provides the ability to reach back to intelligence centers elsewhere in the world. Trojan Spirit and the SMART-Ts cannot operate on the move.

Stryker command vehicles are also equipped with UHF MILSATCOM "Spitfire" terminals. These terminals are equipped with small antennas fitted on Stryker command vehicles. These terminals provide low-bandwidth communication links, typically 24 kbps or less, but they can operate while the command vehicle is on the move and can be used to transmit the common tactical picture to the ABCS.

The last element of the Stryker brigade battalion and above communications network is GBS, which is a high-bandwidth (24

**Figure 4.6**  
**SBCT Trojan Spirit Subnet**

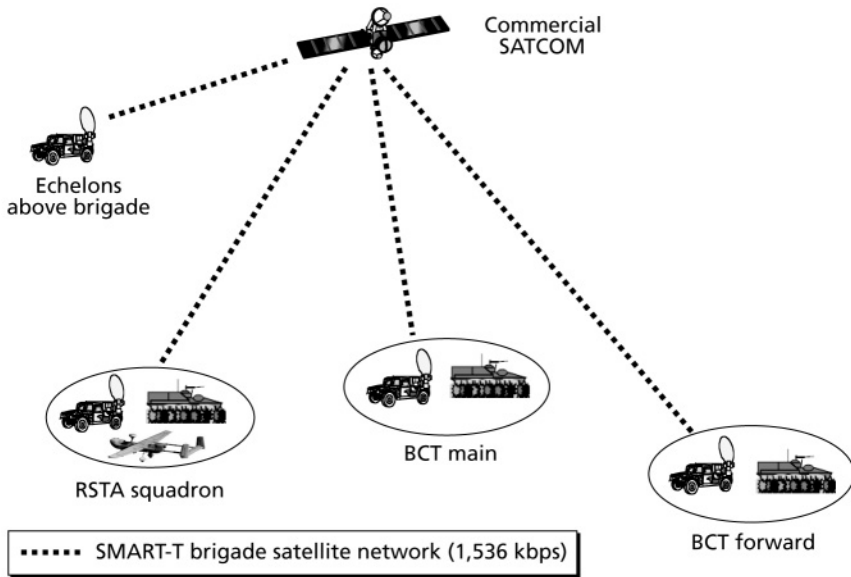

RAND MG267-4.6

Mps per SATCOM transponder) data broadcast network that delivers video, imagery, and other feeds from national information assets to the SBCT. GBS receivers are located at the SBCT main command post, the BSB, the RSTA squadron TOC, and the TOCs of the three infantry battalions.

Division and corps command posts typically employ the SATCOM WAN to make available such information as commander’s guidance, operations and fragmentary orders, intelligence products, operations overlays (for use in the ABCS at brigade, battalion levels), planning documents, and more.

SBCT SATCOM subnets connecting brigade-level SBCT elements with digitally equipped units at division, corps, and echelons above corps are typically reliable and fast, and allow for the posting and retrieval of information to and from digitally equipped units.

Connectivity to nondigitized units can be provided by a Digital Bridge element that deploys with the nondigitized unit to provide the information systems and connectivity to satellite networks needed for linkage to the SBCT's WAN. This digital bridge also facilitates some interoperability between nondigitized units and the SBCT or other ABCS-equipped units.<sup>2</sup>

## Limitations and Improvements to the SBCT Network

The SBCT TI, which is based on EPLRS, has limited communications bandwidth. All Army digitized units suffer from this same bandwidth limitation within the TI. The Army is developing an upgrade to EPLRS that will incrementally increase the bandwidth available within the TI. The long-range plan for increasing network capacity at the tactical level is to eventually replace EPLRS with the Joint Tactical Radio System (JTRS). JTRS will supply significantly more communications bandwidth to tactical vehicles while on the move (perhaps up to 10 Mbps).

Worth noting is the orders-of-magnitude difference in the bandwidth available in the TOC-to-TOC network due to the transmission speed of NTDR (compared to the other components of the SBCT battalion-and-above network). While connectivity is provided, SBCT commanders and observers have noted in exercises that the NTDR bandwidth is insufficient for high-quality collaborative support. Further, the line-of-sight and range limitations of NTDR can constrain the placement of deployed SBCT units within its area of responsibility. To address these shortcomings, future SBCTs may be equipped with a higher-speed (288 kbps) satellite-based TOC-to-TOC network, which would improve support for collaborative applications, remove many of the geographic constraints imposed on SBCT ele-

---

<sup>2</sup> A reasonable question to ask is whether similar digital bridges exist that allow the SBCT to link directly to non-Army, or even non-U.S. units. This kind of linkage was not a part of the CERTEX that was considered in this study and thus is not addressed in this report.

ment placement today, and reduce SBCT reliance on remote (and potentially vulnerable) relay and retransmission assets.

A short-term solution is being implemented to deployed Stryker brigades that grew out of the lessons learned from recent SBCT exercises. This solution involves equipping battalion-level headquarters and the brigade commander's C2 vehicle with commercial SATCOM Very-Small-Aperture Terminals (VSATs). A VSAT hub terminal will be located at brigade main headquarters. The other VSATs will be smaller so they can support on-the-move or on-the-pause operational modes. These VSATs will provide a peak communication link data rate of 1.5 Mbps and an average data rate of 128 kbps.

## **Stryker Brigade Battle Command Systems**

The Stryker brigade battle command system is based on the ABCS, which is also used in the other digitized units of the Army. The Stryker brigade version of ABCS combines digitized C2 and battle management systems that have been developed separately for the different battlefield functional areas into one family of systems. The major component systems of Stryker ABCS are

- Maneuver Control System (MCS),
- Advanced Field Artillery Tactical Data System (AFATDS),
- All-Source Analysis System (ASAS),
- Combat Service Support Control System (CSSCS),
- Air and Missile Defense Workstation (AMDWS),
- Global Command and Control System—Army (GCCS-A), and
- FBCB2.

The component subsystems of ABCS are shown in Figure 4.7.

For example, GCCS-A is the Army component of the Joint GCCS. It provides an interface between joint C2 and Army C2 sys-

**Figure 4.7**  
**ABCS Components**

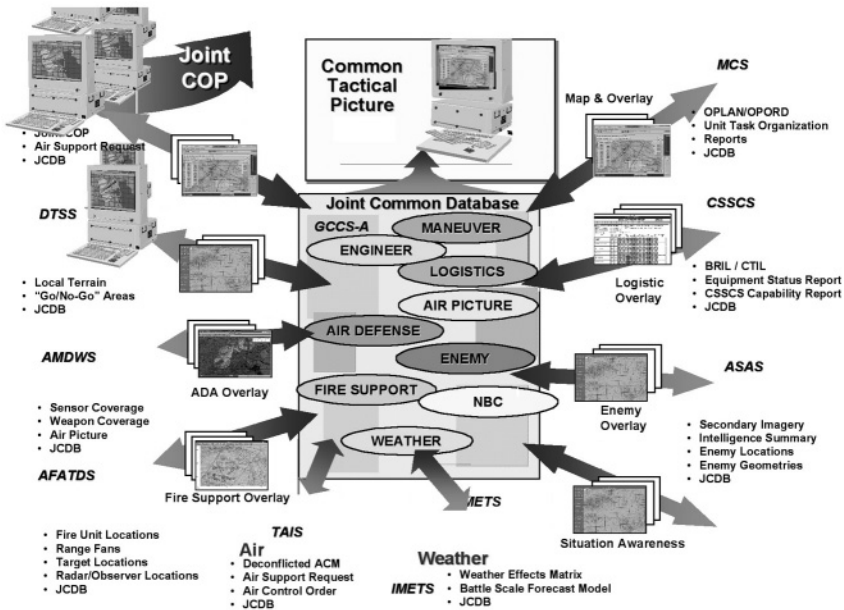

RAND MG267-4.7

tems. MCS supports maneuver planning and also provides the central integrating platform for the Stryker brigade Upper TI COP. MCS is used in the brigade and battalion TOCs and is also available in selected Stryker command vehicles. ASAS is used in the military intelligence (MI) company and brigade and battalion TOCs to develop the “Red” side of the COP. It is used to fuse intelligence and sensor information into a coherent picture of the enemy force. AFATDS is used for fire-support planning and to coordinate and optimize the use of artillery and other long-range fire assets. CSSCS is used to consolidate and collate combat support data. CSSCS also provides tactical commanders with information on ammunition and fuel supplies, medical and personnel status, transportation, maintenance services, general supply, and other field services.



A key component of ABCS is FBCB2. As described above, FBCB2 is now fielded on nearly every Stryker vehicle in operational SBCTs. It provides situational awareness and C2 information to the lowest tactical level and displays the common tactical picture available in the lower TI network. FBCB2 also provides text chat capabilities that have been found useful in recent operations.

The Digital Topographic Support System (DTSS) provides terrain analysis products and can quickly process requests for low-volume reproduction of large-format, high-resolution, multicolor topographic products. Using DTSS, the SBCT can receive digital data in various formats from multiple sources for processing, reproduction, and distribution to SBCT commanders and soldiers.

Also shown in Figure 4.7 is the Tactical Air Information System (TAIS), which was originally designed principally as an airspace management tool. TAIS provides real-time airspace information. It displays the location and movement of aircraft over the battlespace overlaid on Airspace Control Measures established by the joint component commanders in the theater of operation.

The final component of ABCS is the Integrated Meteorological System (IMETS). IMETS can receive, process, and disseminate weather observations, forecasts, and weather and environmental effects information to all battlefield operating systems.

## Summary

Table 4.1 provides an overall summary comparison of the networking and battle command capabilities of Stryker and light infantry brigades. From the table it is apparent that the Stryker brigade has significantly greater capabilities in several areas. In the next chapter, we shall define NCO metrics for situational awareness information quality, network quality of service, network capacity, and network reach and estimate them quantitatively. Suffice it to say here that in all these dimensions the SBCT digital network is far more capable than

the analog voice network available in light infantry brigades. Much less information can be transmitted over voice networks.

Table 4.1 also shows the limited information automation support available to soldiers in a light infantry brigade. This means information must be written down to be retained if it cannot be memorized or remembered by individual soldiers in such units. In contrast, ABCS enables the soldiers of the SBCT to accurately and quickly post and retrieve information.

**Table 4.1**  
**Comparison of Networking and Battle Command Capabilities**

	Light Infantry Brigade	Stryker Brigade
Network system components	FM radio (CNR)	EPLRS, NTRD, MILSATCOM, CNR commercial SATCOM
ABCS	None	ABCS —MCS —AFATDS —ASAS, etc.
Quality of service/link capacity	Voice (poor quality)	Voice, data (14 to 1536 kbps), imagery, videoteleconferencing
Post and retrieve capability	Very limited, not automated—multiple maps with “stickies”	Yes, multiple methods
Situational awareness data quality <sup>a</sup>	Poor (incomplete, inaccurate, late)	Blue (good when soldiers mounted) Red (scenario dependent)
Reach <sup>a</sup>	Limited	Good

<sup>a</sup>These NCO metrics will be described in detail in Chapter Six.

## **SBCT Scenario at JRTC**

---

The SBCT conducted its CERTEX and Operation Evaluation at the JRTC in May 2003. The scenario was based on early-entry operations in an SSC on the notional island of Aragon. The SBCT was under the tactical control of the 21st Infantry Division (Light) represented by the JRTC Operations Group.

### **Enemy Situation**

The enemy situation reflects the challenging operating environment faced by our forces today. An enemy conventional brigade tactical group was moving south to attack the SBCT at the same time three company-size groups of insurgents defended the approaches and the town of Shughart-Gordon. Enemy Special-Purpose Forces were also conducting raids throughout the area of operations, especially against the friendly forward operating base at the airfield. Additionally, criminal organizations, civilians, international media, and nongovernmental organizations were on the battlefield. The terrain was complex and restricted, with dense forests and urban centers.

The enemy's tactical course of action had two company-size groups defending in the 15 kilometer-wide disruption zone east of Shughart-Gordon. The purpose was to destroy friendly reconnaissance elements, deny the high-speed avenues of approach, delay the friendly advance, and inflict attrition on friendly forces. One com-

pany-size group of insurgents defended the town of Shughart-Gordon in the battle zone with squad positions shown in red in Figure 5.1. The enemy had time to prepare a deliberate defense in urban terrain, integrating wire and mine obstacles (shown in green and yellow, respectively) with direct and indirect fire. This would be an extremely difficult scenario for friendly forces, with most attacks ending in failure or at best mutual destruction.

## Friendly Situation

The friendly situation was typical of early-entry operations in an SSC but not typical of the “Standard JRTC rotation.” The SBCT was

**Figure 5.1**  
**Enemy Situation in Shughart-Gordon**



tasked to conduct the simultaneous, distributed, full-spectrum operations in a 50 kilometer by 50 kilometer zone.

For example, while the SBCT was preparing to attack to seize objective Blaze (Shughart-Gordon) in area of operations Bear, it was simultaneously preparing to defend against a Brigade Tactical Group attack in area of operations Gator (virtual CPX) and conducting stability and support operations to help and protect the local civil authorities. No light infantry or armor/mechanized brigade had ever conducted these simultaneous, distributed, full-spectrum operations in a training center rotation before. Analysis of relative combat power at Shughart-Gordon during the SBCT CERTEX revealed a 2:2 friendly “advantage,” well below the historical planning ratios of 3:1 for an attack and 6:1 for an attack in urban terrain and also well below a force ratio of 4:2, which is the typical force ratio encountered in light infantry brigade rotations at the JRTC.<sup>1</sup>

The SBCT mission was to attack to seize objective Blaze (Shughart-Gordon) no later than 6:00 a.m. on May 25, 2003 to restore Shughart-Gordon to host nation control. The commander’s intent and concept of operations was predicated on gaining and exploiting information advantage. Figure 5.2 depicts the situation shown in an MCS “screen shot” taken the day before the battle. The town of Shughart-Gordon is depicted as “objective Blaze” in the northwest quadrant. The black lines are unit operational graphics, such as phase lines, unit boundaries, and checkpoints to control movement.

The RSTA squadron (shown in yellow) was tasked to conduct reconnaissance of the routes and the objective area of Shughart-Gordon. This reconnaissance supported the key brigade decision point, which was to attack north or south of Lake Bear, depending on which avenue of approach was more favorable. The lead infantry

---

<sup>1</sup> Personal communication from an experienced JRTC observer controller.

**Figure 5.2**  
**SBCT Concept of Operations**

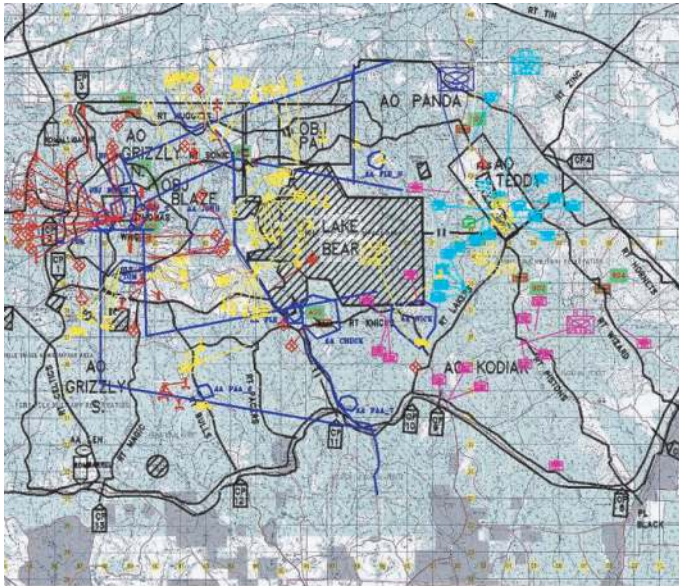

RAND MG267-5.2

battalion (shown in blue) was tasked to clear enemy forces and obstacles in the disruption zone and isolate the objective to support the main effort. The main effort infantry battalion (shown in purple) was tasked to attack to seize Shughart-Gordon. This was the decisive operation.

The main idea behind this concept of operations was to locate and bypass 66 percent of the enemy's strength in the disruption zone and conduct precision maneuver to attack the enemy's weakness at Shughart-Gordon, thus exploiting information and decision superiority.

## Stryker Comparison to the Baseline

---

In this chapter, we compare the performance and capabilities of the Stryker brigade to that of the baseline unit in a number of key dimensions. We use the metrics of the NCO CF to compare the performance of a Stryker brigade to a typical light infantry brigade using the NCO concepts described in Chapter Two.<sup>1</sup> The NCO concepts that we examine are the following:

- Degree of networking
- Quality of shared and individual information
- Quality of interactions and collaboration
- Speed of command (a measure of C2 agility)
- Degree of command and force synchronization
- Several measures for overall unit force effectiveness.

For some of these NCO concepts and their associated measures and metrics, a quantitative analysis is possible, using engineering-level data (for example, for the degree of networking). However, for other NCO concepts, a qualitative analysis was only possible in the context of this study because of resource constraints or because quantitative

---

<sup>1</sup> When we estimated the capabilities of a typical light infantry brigade, we used an average level of performance for such units. These average performance assessments of a typical light infantry brigade were obtained in interviews with JRTC observer controllers, with experienced Army commanders who have served in light infantry brigades, and with civilian subject-matter experts.

data were not available. To a large degree, for many of the other NCO concepts shown above we relied on interviews with key participants in Stryker brigade exercises, individuals experienced with light infantry brigade exercises, and JRTC observer controllers. Further details on these interviews and the interview participants are given later in this chapter. A key interview instrument we used is included in Appendix C as well. First we examine the networking capabilities of the Stryker brigade and the baseline unit.

## **Networking**

The Stryker brigade communications network provides substantial capabilities to the soldiers and commanders of this unit. As we show below, the Stryker brigade network is a significant improvement over the voice-only “network” in the baseline unit equipped only with FM radio. In this chapter, we compare the capabilities of the light infantry brigade network to the network available in the Stryker brigade.

The NCO CF includes metrics for assessing performance of the network and the nodes connected to a network. These metrics can be divided into two broad categories. The first category is network-ready nodes. This set of metrics describe the capabilities of the network terminal equipment, including wireless radios, that individual nodes or platforms possess in a unit or force. In the case of a light infantry brigade, all vehicles and soldiers carry the same type of analog voice radio. The second broad category of measures is the degree of networking.

### **Network-Ready Nodes**

The network-ready nodes measure we use for voice communications is simply a binary measure of yes or no for this capability. The net readiness score for light infantry brigade nodes (both vehicles and dismounted soldiers) for voice communications is shown in Table 6.1.



**Table 6.1**  
**Comparison of Network-Ready Node Metrics**

<b>Network Ready Nodes</b>	<b>Light Infantry Brigade</b>	<b>Stryker Brigade</b>
Voice communications	Yes	Yes
Data communications (non-C2 vehicles)	0 kbps	56 kbps (maximum)
Data communications (data rate for C2 vehicles)	0 kbps	8,000 kbps (maximum)
Data communications—dismounted soldiers	0 kbps	0 kbps

While the radios of a light infantry brigade soldier or vehicle may have a limited data communications capability, most radios in the light infantry brigade are used only for voice communications. A common measure of data communications capability is the maximum capacity of the radio system or terminal in kbps. Thus, for light infantry brigade nodes (both vehicles and dismounted soldiers) the net readiness score for data communications is on average zero (no capability), as shown in Table 6.1.

As described in Chapter Four, in the Stryker brigade all combat vehicles have voice and some data communications capabilities. The network-ready nodes in the heterogeneous Stryker brigade communications network have distinct and different data communications capabilities. For example, dismounted soldiers in the Stryker brigade are equipped in the same way as dismounted soldiers in a light infantry brigade and have the same net readiness scores as soldiers in a light infantry brigade (the Army is working to remedy this shortcoming for dismounted soldiers in the Stryker brigade). The maximum data rates that different types of combat vehicles have in the Stryker brigade are shown in Table 6.1.

### **Degree of Networking**

This measure consists of three attributes that describe the capabilities of the network as a whole. The first attribute, reach, addresses the degree to which force entities or network-ready nodes can interact with each other using the network. The second attribute, quality of

service, focuses on the type of communications services provided by the network as a whole. It includes the capacity or bandwidth of the connection and the format or data services provided (e.g., voice, text data, or full videoconferencing). The last attribute, network assurance, addresses the expectations that force entities will have good connectivity. This includes the security, privacy, and integrity of the network and its contents.

### Quality of Service

Table 6.2 compares the quality of service provided by the light infantry brigade and Stryker brigade networks. One will note that the data rates for communication links to both non-C2 and C2 vehicles in the Stryker brigade are significantly smaller than those listed in Table 6.1, which shows the maximum possible data rates for network-ready nodes. The reason for this difference is that the data communications networks used in the Stryker brigade are multiaccess networks—that is, more than one vehicle or node typically uses or participates in the network at the same time. Because of this, the network resource of capacity or bandwidth must be shared among many different vehicles or nodes. What results then is a quality of service available for the typical network-ready node in the network, which is precisely what is shown in Table 6.2.

**Table 6.2**  
**Comparison of Degree of Networking Metrics**

Network Ready Nodes	Light Infantry Brigade	Stryker Brigade
Voice communications	Yes	Yes
Data communications (non-C2 vehicles)	0 kbps	14 kbps (average)
Data communications (data rate for C2 vehicles)	0 kbps	28 kbps (average)
Data services (combat vehicles, on the move)	None	Text, COP tracks, graphic overlays
Data communications—dismounted soldiers	0 kbps	0 kbps

Also shown in Table 6.2 are the data services typically available to either unit. No such services are available in the light infantry brigade, whereas in the Stryker brigade several types of data services are available, as already seen in this report and as summarized in Table 6.2. The final point highlighted by Table 6.2 is that in both types of unit dismounted soldiers lack data communications capability at present.

In baseline voice command nets, the soldiers and commanders of the unit are preoccupied with obtaining basic situational awareness—unit location and status. Looking at other metrics to measure the quality of the network, the light infantry brigade had poor quality of service, limited reach and capacity, and no information post-and-retrieve capability.<sup>2</sup> If the brigade commander missed the radio message on the brigade command net because he was talking to his battalion leaders or to his own driver, then he missed the information.

In contrast, the Stryker brigade has a TI that relies on FBCB2 and EPLRS for enhanced situational awareness at battalion level and below. This network is reliable with good reach and post-and-retrieve capabilities. The SBCT's upper TI uses NTDR and SMART-T SATCOM for enhanced situational awareness at battalion level and above.

### **Network Reach in the Stryker Brigade**

A key measure in the NCO framework for assessing the capabilities of a network is *reach*, which describes whether the system of interest can “communicate in desired access modes, information format, and applications” without interface or interoperability constraints (Evidence Based Research, 2003).

First, consider network reach in the SBCT during mounted maneuver operations (when all infantry soldiers are mounted on Stryker vehicles). To quantify the reach of the SBCT network during

---

<sup>2</sup> Note that the terms reach, capacity, quality of service, and post-and-retrieve capability refer to NCO capability metrics defined in the NCO CF.

mounted operations, we focus on the transmission of situational awareness via the EPLRS network and FBCB2. If FBCB2/EPLRS were present on half of all ICVs at the platoon level, the unit would have a “direct” reach of 0.5.

As noted earlier, the doctrinal employment of ICVs not equipped with FBCB2/EPLRS (the lead vehicle with wingman policy) and the connectivity of the EPLRS-lacking wingmen to their leads via CNR provides enough propagation of situational awareness to the platoon’s wingmen to allow them to maneuver and be employed effectively. Further, as noted above, all Stryker brigade combat vehicles are now equipped with FBCB2, so the wingman situational awareness dissemination policy over voice networks is no longer needed. As a result, the reach of the SBCT network (for situational awareness) equals 1.0 (the maximum), because no human gateways or translation devices are needed to share situational awareness information between any two combat vehicles in the brigade).

We now briefly consider network reach for dismounted configuration for SBCTs. When dismounted, situational awareness information from an SBCT infantry squad member is introduced into the brigade via voice, as in the light infantry brigade. However, once that information reaches the platoon net, it can be digitally introduced into the SBCT digital network and suffers no further degradation from the influence of additional human gateways. Still, the voice linkages required for the “last mile” of connectivity to a dismounted soldier in the SBCT to reduce the SBCT network reach to less than one in dismounted operations. The dismounted SBCT network configuration was not part of this study, however, and attempts to quantify the effects of a mixed voice/digital network are beyond its scope. That said, multimode networks are common, and such a study could yield interesting insights into their effectiveness.

### **Network Reach in the Light Infantry Brigade**

We now consider the reach of the light infantry brigade network, which consists of a large number of voice subnets connected by gate-

ways. Because of the large number of gateways in this network, the calculation of each is complicated. While the voice nets of the baseline light infantry brigade extend down to squad level, aspects of this network result in its being less effective than its technical connectivity suggests (the topology of this network is illustrated in Figure 6.1). First, the gateways between the subnets in the brigade's voice net are human—and therefore involve human decision processes as messages cross between subnets (these gateways are indicated by the intersections of the circles or subnets). Each time a piece of information traverses one of these gateways (or hops from one circle to the other in the figure), another opportunity for filtering, receipt failure, misinterpretation, and delay is introduced. This situation is exacerbated by the fact that the messages that travel on this network are real-time

**Figure 6.1**  
Exploring the Reach of the Baseline Case

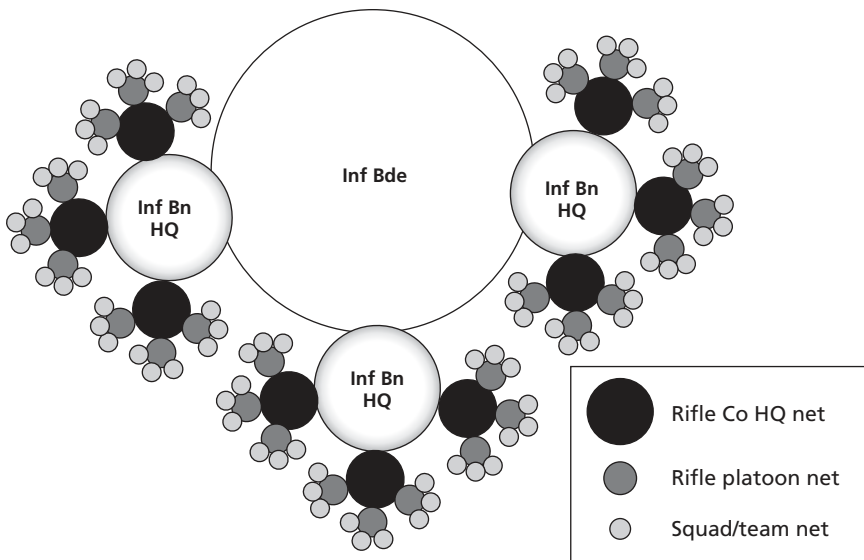

voice messages. Unlike the data measures in the SBCT's network, messages on the voice net must be listened to and understood, and then a *new* message, hopefully containing an accurate copy of the information, is created by the gateway to pass the information on to another subnet.

As a result of this degradation, we find that the connectivity structure of the baseline's voice nets makes it well-suited for some types of information exchange but poorly suited for others. If connectivity is *between* subnets (i.e., if a human gateway is used) instead of *within* a single subnet, the reach for that type of activity is less than it would be if direct communication were possible.

To illustrate, consider the following four examples, shown in Figure 6.2: a company commander receiving spot reports from his platoon leaders, platoon leaders within a company talk to coordinate maneuver, the brigade commander receiving information that was part of a squad member's spot report to his squad leader, and a company commander passing information to a company commander in another battalion in the brigade.

In each of the first two examples, only one subnet is used—the platoon leaders are part of the gateway between the platoon and company voice nets, and the company commander is part of the gateway between the company and battalion nets. Thus, in both examples, the company net can be used for these information exchanges. Because no gateways must serve as intermediaries, the reach is maximal for this type of transaction.

The third and fourth examples are not so straightforward. If a piece of information originating in a squad member's report to his squad leader, five different subnets must be used (squad, platoon, company, battalion, brigade), reflecting the five gateway transactions that had to take place in this information path (squad member to squad leader, squad leader to platoon leader, platoon leader to company commander, company commander to battalion commander, and battalion commander to brigade commander). It would appear

**Figure 6.2**  
**Voice Net Structure Affects Reach: Examples**

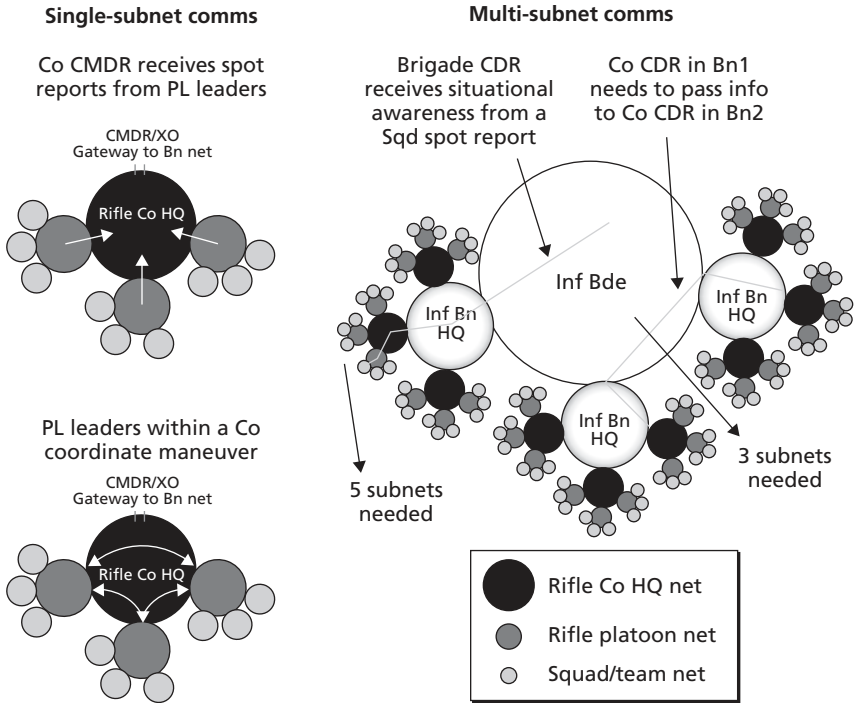

RAND MG267-6.2

that the structure of the light infantry brigade’s voice nets is not well-suited for this type of vertical information exchange. Likewise, the network’s structure for cross-elemental interaction seems poor, as well. For the two company commanders in example 4 to interact (aside from changing radio frequencies to talk directly and then changing back once the conversation is complete), three different subnets are required (battalion 1, brigade, and battalion 2). Figure 6.3 illustrates the complexity of the light infantry brigade’s voice network.





inverse function of the number of subnets,  $d_{ij}$ , involved in that link that have only human gateways (a measure of the network distance between  $i$  and  $j$ ):

$$R_{ij} = \frac{1}{d_{ij}} .$$

Given how  $d_{ij}$  is measured (number of subnets involved), it is constrained to be greater than or equal to 1, resulting in a reach contribution bounded between 0 (infinite distance, or no link, between  $i$  and  $j$ ) and 1 ( $i$  and  $j$  are on the same subnet).

For our baseline calculation, we will focus on how situational awareness information propagates from throughout the brigade to the brigade commander. Thus, in the equation above, we take node  $j$  to be the brigade commander, and  $d_{ij}$  is the number of subnets with human gateways involved as information moves from the  $i$ th element (an arbitrary brigade member) to the brigade commander. To arrive at  $R_j$ , the reach of this system of voice nets linking to the brigade commander, we take the average of individual reach contributions over all links of interest.<sup>3</sup>

$$R_j = \frac{1}{n} \sum_i R_{ij}$$

where  $n$  is the number of nodes in the brigade network.

Because the voice nets of the light infantry brigade are structured hierarchically, with the brigade members at each subnet level distanced identically from the brigade commander, this equation can be simplified to sum over the reach contributions from the links

---

<sup>3</sup> In this case, the links of interest are those from each force element to the brigade commander. For this calculation, we will presume it equally likely that relevant information can originate from any individual in the network, a reasonable assumption when assessing the *structure* of a network absent a particular operational context. This assumption allows us to place equal weights on the network's links.

originating at each subnet level rather than the reach contributions from each link individually. For each subnet, the reach contribution of the links from that subnet to the brigade commander is

$$R_{sj} = \sum_{\text{all } i \text{ in } s} \frac{1}{d_{ij}} = \sum_{\text{all } i \text{ in } s} \frac{1}{d_{sj}} = \frac{n_s}{d_{sj}},$$

where  $d_{sj}$  is the number of subnets with only human gateways involved in a link from a node on subnet  $s$  to the brigade commander,  $d_{ij} = d_{sj}$  for a node  $i$  on subnet  $s$ , and  $n_s$  is the number of nodes on subnet  $s$ . Now, summing over the subnets yields the reach of the network:

$$R_j = \frac{1}{n} \sum_s R_{sj} = \frac{1}{n} \sum_s \frac{n_s}{d_{sj}} = \sum_s \frac{n_s}{n} \frac{1}{d_{sj}} = \sum_s \omega_s \frac{1}{d_{sj}},$$

where  $\omega_s$  is the fraction of force elements that connect into the brigade voice net at the  $s$  subnet level.

This reach metric is bounded by 0 (no ability to link to the brigade commander) and 1 (all brigade elements are directly linked to the commander).<sup>4</sup> Calculated results for the light infantry brigade are shown in Table 6.3.

In the baseline light infantry brigade, as discussed previously, no digital systems are available to propagate situational awareness information. Thus, the unit must rely solely on its internetwork of radio voice nets for situational awareness. Using the procedure and network participation numbers on the previous figures (which were taken

---

<sup>4</sup> As this interpretation of a reach metric of 1 indicates, there may be very good reasons for the reach of a network to be less than one; it can hardly be considered a good thing to have thousands of brigade personnel sharing a voice link to the brigade commander. However, if information can be transmitted digitally and presented graphically, immense connectivity can indeed be practically utilized at a scale not possible with voice/analog networks.

**Table 6.3**  
**Reach Calculation for Light Infantry Brigade: Brigade Commander Down to Squad Member Level<sup>a</sup>**

Voice Net	Participants <sup>b</sup>	$\omega_s$	$K_s$	$K_s$	Comments
Squad	792	0.7070	5	0.1410	Assuming 9-person squads (Sqd Ldr on PL net)
Platoon	105	0.0938	4	0.0234	27 Rifle Sqd Ldrs, 8 SCT/MTR/SPT Sqd Ldrs per Bn
Company	84	0.0750	3	0.0250	PL Ldrs, PL Sgts, Co HQ SEC Ldrs
Battalion	99	0.0884	2	0.0442	Co CDRs/Co XO's (Inf and HHC) plus Bn Staff
Brigade	40	0.0357	1	0.0357	Bde XO, Bde S3, Bde FSO, Sig Off, Bde S2, Bde ADO, FSB CDR, BDE Engineer, Bde Tactical CP, OPCON/ ATCH Unit CDR CP, Bn CDRs/XOs, Bde HHC CDR/XO
<b>Total:</b>	<b>1,120</b>				<b>Reach: 0.270</b>

<sup>a</sup>Columns do not add because of rounding.

<sup>b</sup>Subnet participant counts used in the reach calculation were derived from U.S. Army (1992) and U.S. Army (1995).

from the 7-series U.S. Army Field Manuals), the reach of the light infantry brigade's voice networks is 0.37 for situational awareness information originating at the level of the squad leader (who is on a platoon-level subnet) and above. This echelon cutoff is comparable to the "mounted" configuration for the SBCT, in which squad personnel are with their FBCB2/EPLRS equipped vehicles.

In the light infantry brigade, when the effects of information transactions from the squad member level are taken into account, the average reach for the brigade drops to 0.27 (the elements of this calculation are detailed in Table 6.1).<sup>5</sup>

<sup>5</sup> In the baseline reach calculation in the previous paragraph (corresponding to the mounted SBCT configuration), the squad member level is simply truncated from the calculation, and the summation is only performed to the platoon subnet level.

## Comparison of Reach Metrics

Figure 6.4 summarizes the reach metric calculations for the SBCT and baseline networks for situational awareness information. The reach calculation for SBCT was based on the presence of the digital EPLRS network, augmented by voice for dismounted SBCT operations.

All possible aspects of the dismounted SBCT network configuration were not assessed quantitatively in this study. The comprehensive quantitative analysis of NCO CF metrics for mixed voice/digital network is beyond the scope of this report. That said, multimode networks are common, and a study about them could yield interesting insights into their effectiveness.

## Quality of Individual and Shared Information

Two independent sources were used to compare the quality of individual and shared information in the SBCT versus the light infantry

**Figure 6.4**  
**Comparison of Reach Metrics for SBCT and Baseline**

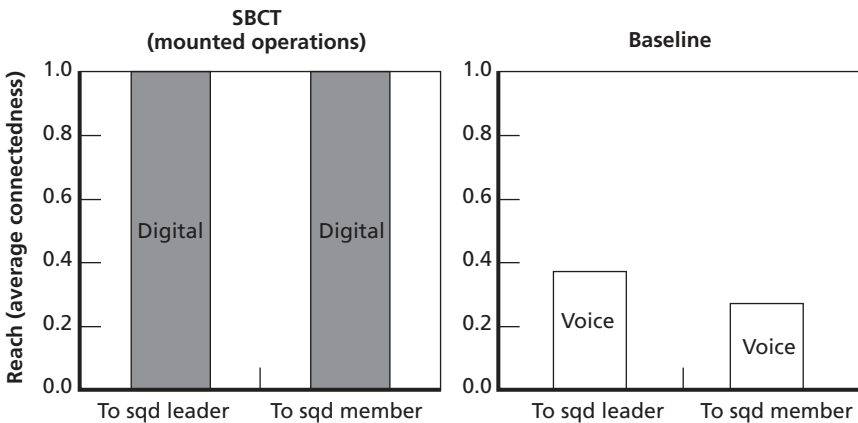

brigade. The first was interviews with a lieutenant colonel who was the SBCT infantry battalion commander of the main effort during the attack to seize Shughart-Gordon and another lieutenant colonel who was a member of the Operational Evaluation Control Group (OECG) and had 24 rotations of experience with Shughart-Gordon attacks as a JRTC observer controller. The third source was survey questions administered by the SBCT OECG to Stryker soldiers and JRTC observer controllers. This was part of the database the Army compiled to prepare the formal operational evaluation report submitted to Congress. It should be noted that RAND had no control over the interview questions used in the OECG SBCT survey.

## **Context and Caveats**

In any conflict or engagement, the quality of information is constantly changing, depending on the mission and interaction with enemy forces. The data below reflect the aggregate quality of information achieved after 60 hours of reconnaissance before a deliberate attack on Shughart-Gordon at the JRTC. The SBCT or light infantry brigade cannot sustain this quality of information about the enemy at all times in this training scenario.

The surveys that were given to soldiers in the SBCT or observer controllers at the JRTC included questions on both the SBCT and light infantry brigade. Soldiers from a light infantry brigade were not interviewed because of the short timeline for this project. However, it should be noted that many soldiers in the SBCT and all the SBCT commanders we interviewed have also served in light infantry brigades. JRTC observer controllers have also assessed the performance of light infantry brigades in conducting the Shughart-Gordon attack. Both interview populations have credible experience and backgrounds to make comparisons between the SBCT and light infantry brigades. Consequently, we used these same interviewees to make assessments of the performances of light infantry brigades at the JRTC.

**Primary Interview Results**

The first interview question concerned the NCW metric completeness, asking “to what extent was information relevant to ground truth collected and posted in ABCS before the Shughart-Gordon attack?”<sup>6</sup> The SBCT had much more complete information (relative to ground truth) before the Shughart-Gordon attack than the light infantry brigade did. Information about the enemy forces increased from 10 percent to 80 percent, as shown in Figure 6.5.<sup>7</sup> Information about

**Figure 6.5**  
**Quality of Information—Interviews (I)**

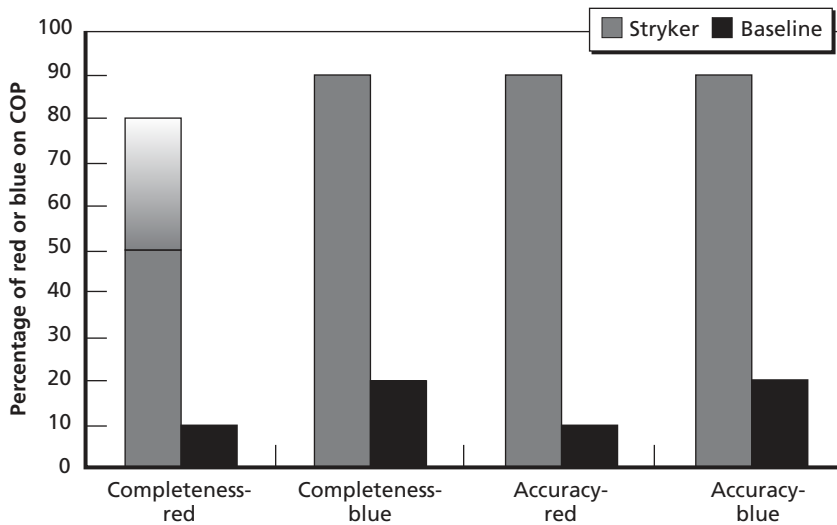

SOURCE: RAND Survey of selected SBCT leaders and JRTC observer controllers.

RAND MG267-6.5

<sup>6</sup> Appendix C contains all questions used in the interview.

<sup>7</sup> A 10 percent information completeness metric for Red means that on average, only 10 percent of the Red force was represented on the COP or in the mind of the soldiers in the unit in question where the average is taken over the ABCS used in the SBCT or over the soldiers in the light infantry brigade unit.

forces increased from 20 percent to 90 percent—the remaining difference being dismounted infantry and those vehicles without FBCB2 global positioning systems (GPSs). Because of the ABCS network, this situational awareness information was easily shared among the staff and subordinate units within the Stryker brigade.

The second interview question concerned the NCW metric accuracy, asking “to what extent did you receive the accurate information necessary to answer Commander’s Critical Information Requirements (CCIR) for the Shughart-Gordon attack?” CCIR is the essential information that the commander needs to know about enemy and friendly forces to make command decisions. The information to answer Priority Intelligence Requests (PIRs) about enemy forces increased from 10 percent to 90 percent.<sup>8</sup> Information

---

<sup>8</sup> For example, the SBCT initial PIR were:

*Phase I:*

Where are mines and obstacles that can affect 3/2 SBCT movement in AO BEAR?

Where are SPM indirect-fire assets that can affect operations?

Where are the SA-18s located that can affect operations?

Where will SPM and PRA forces employ chemical munitions?

What is the disposition of the civilian population centers to the SPM/PRA and U.S. forces?

*Phase II:*

Where are mines and obstacles that can affect 3/2 SBCT movement in AO BEAR?

Where are SPM indirect-fire assets that can affect operations?

Where are the SA-18s located that can affect operations?

Where will SPM and PRA forces employ chemical munitions?

What is the disposition of the civilian population centers to the SPM/PRA and U.S. forces?

Where are the counter-recon elements?

*Phase III:*

Where are mines and obstacles that can affect 3/2 SBCT movement in AO BEAR?

Where are the SPM indirect-fire assets that can affect operations?

Where are the SA-18s located that can affect operations?

Where will SPM and PRA forces employ chemical munitions?

acquired to answer friendly force information requirements increased from 20 percent to 90 percent. The result being, CCIR becomes a useful tool for information management and battle command because the commander's questions are answered and updated.

The third interview question concerned the metric currency, asking, "How long did it take you to receive accurate information during the Shughart-Gordon attack?" The results of this part of interviews are shown in Figure 6.6. Where it used to take 12 hours to receive accurate information about enemy forces in a light infantry brigade, which was usually received at JRTC in the after-action review, now any observer in the SBCT can send a spot report on FBCB2 or populate the database with an enemy icon in two minutes. Within an hour, SBCT commanders can receive useful analytical information from the S-2 (intelligence officer). Likewise, where it used to take four hours to receive accurate information about friendly forces in the light infantry brigade, now unit location and status are updated every two minutes or 500 meters moved in the SBCT. Further, the SBCT can adjust these FBCB2 settings to the desired level.

### Results in Terms of Information Position

One can display the Quality of Information metrics shown in Figure 6.5 in another way that shows the dramatic difference between the

---

What is the disposition of the civilian population centers to the SPM/PRA and U.S. forces?

When and where will the 24th DTG support/reinforce SPM in AO BEAR?

Where will the 373rd PRA reinforce AO BEAR?

*Phase IV:*

When and where will the 24th DTG support/reinforce SPM in AO BEAR?

Where will SPM and PRA forces employ chemical munitions?

Where will the 373rd PRA reinforce AO BEAR?

What is the disposition of the civilian population centers to the SPM, PRA, and U.S. forces?



**Figure 6.6**  
**Quality of Information—Interviews (II)**

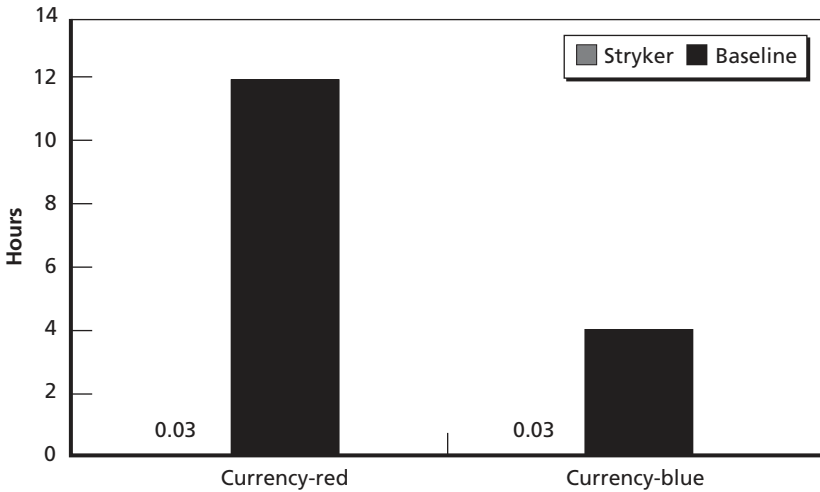

SOURCE: RAND Survey of selected SBCT leaders and JRTC observer controllers.

RAND MG267-6.6

Stryker brigade and the baseline unit. Shown in Figure 6.7 are the information positions of the SBCT and a typical baseline unit.<sup>9</sup> If one equates the area under the two lines to the information position of the two types of units, then the SBCT's information position is more than 40 times greater than that of a typical baseline unit.

### **Operational Evaluation Control Group (OECG) Interview Results**

The primary interview responses are supported by a separate wider survey, independently conducted by the OECG. In this Army survey, 91 percent of Stryker soldiers surveyed believed their ABCS battle-field visualization tools were an improvement over their experience in

<sup>9</sup> "The *Information Position* of an actor (or unit) is defined as its information state at a given point in time. In essence, this is a summary of how much information the actor possesses." For more details, see Alberts et al. (2001).

**Figure 6.7**  
**Stryker Brigade and Baseline Information Positions**

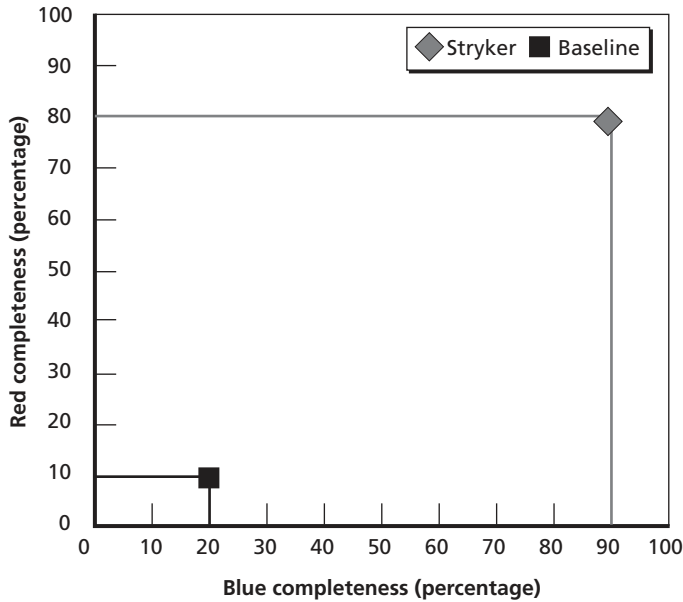

RAND MG267-6.7

nondigital units. Eighty-one percent of Stryker soldiers surveyed believed they received accurate and useful (relevant and needed) intelligence information for planning and executing operations. Eighty-six percent of Stryker soldiers rated their own personal situational understanding as adequate or better. Ninety percent of Stryker soldiers believed their staff estimates reflected ground truth. These results are shown in Figure 6.8 and Figure 6.9. It should be emphasized that the Army OECG survey questions were not designed to address the analytical questions considered in this report. Nevertheless, these survey responses indicate what SBCT soldiers thought about the information they received from SBCT networked battle command systems. These results are consistent with the results of the RAND survey responses.

**Figure 6.8**  
**Quality of Information—Operational Evaluation Surveys (I)**

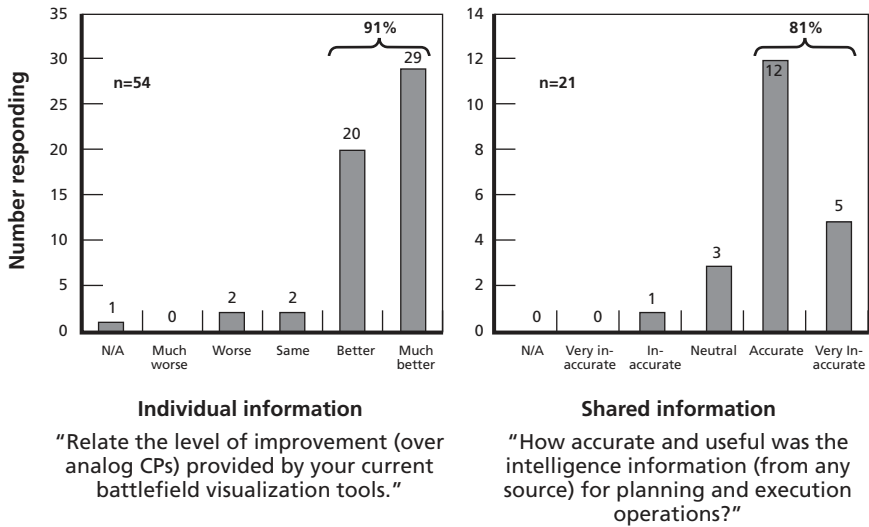

SOURCE: Army OECG survey of SBCT personnel.

RAND MG267-6.8

These interview and survey responses reveal a significant increase in the quality of individual and shared information. In a typical light infantry brigade attack, the enemy achieves information advantage by winning the reconnaissance battle. The brigade has limited accurate information about the enemy before it attacks, forcing it to make contact and then develop the situation. In contrast, the SBCT gained and exploited information advantage during the Shughart-Gordon attack. It is important to understand that human eyes in the RSTA squadron—not technical sensors—won this reconnaissance battle. The UAV was used to confirm details about enemy size, activity, and location after their presence was detected by RSTA troops. The quality of information about the enemy resulted in an 80 percent accurate “read” of enemy forces and locations, with only isolated areas that lack intelligence. This degree of information advantage provided better decision options: the Stryker brigade selected the

**Figure 6.9**  
**Quality of Information—Operational Evaluation Surveys (II)**

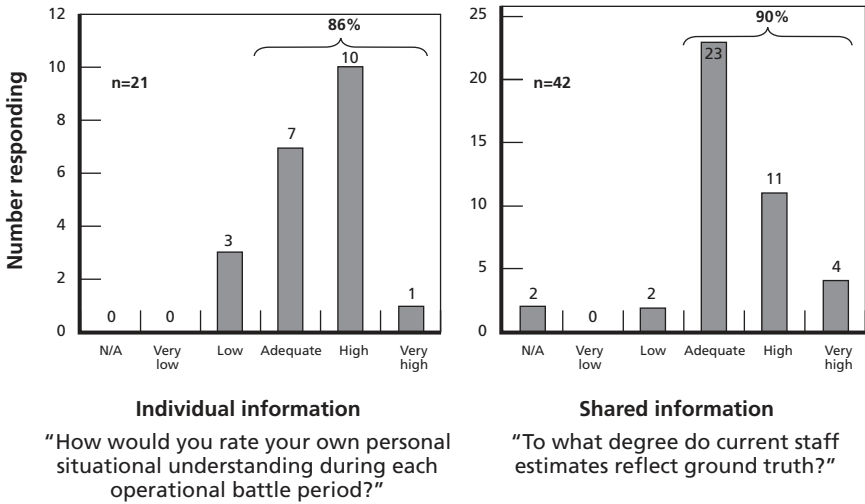

SOURCE: Army OECG survey of SBCT personnel.  
 RAND MG267-6.9

best avenue of approach to bypass 66 percent of the enemy’s strength in the disruption zone and achieve surprise at Shughart-Gordon. The enemy did not know the location of the SBCT infantry battalions or intended route of advance until after they had penetrated the disruption zone and lacked the ability to make, communicate, and implement decisions fast enough to prevent the SBCT from accomplishing its mission at Shughart-Gordon.

### Quality of Interactions and Collaboration

The SBCT network significantly improves the quality of interactions and collaboration compared to that of a nondigital light infantry brigade. Where there was limited interaction by FM radio or group meetings in the light infantry brigade, widespread interaction occurred in the SBCT because every leader is on the ABCS network.

For example, commanders and staff officers make continuous and effective use of such capabilities as FBCB2 text messaging, AFATDS messages, ASAS reports, CSSCS requests, chat programs, email, and network file servers. The specific subjects of interaction discussed are the brigade commander's location, the military decisionmaking process (MDMP), the SBCT battle rhythm, and the SBCT synchronization meeting.

In the light infantry brigade, the commander was either forward with his subordinate units before battle to ensure they were prepared and understood his intent or he was in the command post collaborating with his staff during the MDMP. This was an either/or choice. However, in the SBCT, the brigade commander can leverage the network capabilities to do both important tasks. He can be forward with subordinate units and still collaborate with his staff by videoconferencing (VTC) in his commander's vehicle. This allows significantly more interaction between commander and staff during planning, making the process better at supporting the commander's decisionmaking and more grounded in reality. JRTC observer controller's confirmed this capability, noting, "The Stryker brigade best exemplified this capability with collaborative planning during all phases of CERTEX between the main [command post] and the tactical [command post]. VTC capability should be expanded to lower echelons. . . . It is a tremendous tool that would enhance situational awareness/situational understanding. . . . Further distribution would further facilitate collaborative and parallel planning."<sup>10</sup>

NCW capabilities improve interaction and collaboration during the military decision-making process in the SBCT in several ways. SBCT doctrine states: "The MDMP adapts the Army's analytical approach to problem solving. . . . The digitization of our Army and its battlefield operating systems has not changed the steps of the

---

<sup>10</sup> *Senior Observer Controller Summary*, SBCT JRTC Operational Evaluation Database, May 2003.

MDMP; it has enhanced them.”<sup>11</sup> While this may be a true statement, it does not adequately describe the significant modifications in the practice of military decisionmaking or the digital “enhancements” of the MDMP steps. The practice of MDMP in a nondigital light infantry brigade was generally linear, methodical, and time-consuming. In the SBCT, it is more abbreviated and flexible. There is greater nonlinear feedback, as the staff continuously updates its situational understanding (mission analysis) and COP (enemy situational template) and uses that to refine courses of action. The commander and staff often rapidly move through the MDMP steps issue by issue. Interaction between commander and staff and between brigade and battalions in the SBCT also significantly increased. For example, the brigade staff shared ideas during mission analysis with the brigade commander who was forward checking on battalions. The brigade commander discussed the situation with the battalion commander. Later, the brigade commander shared his concepts for three courses of action with subordinate commanders, asking for their assessment of the situation and recommendations.

Planning products are also “posted to the network” for subordinate units to download and provide feedback. The initial emphasis of MDMP in the baseline was the Intelligence Preparation of the Battlefield (IPB), which often took hours to define the S-2’s “best guess” about most likely and most dangerous enemy courses of action. In the SBCT, there is less emphasis on IPB but more emphasis on ISR planning, collection, and analysis to fill gaps in their shared awareness and understanding. The product of the baseline MDMP is typically a detailed order based on an estimate of the enemy’s course of action that was frequently wrong. The product of the Stryker MDMP before the Shughart-Gordon attack was a mission order describing two options for employment based on their accurate “read” (situational understanding) of the enemy’s actual course of action.

---

<sup>11</sup> FM 3-21.91, *Stryker Brigade Combat Team*, p 2-10.

Figure 6.10 shows the many instances of internal and external collaboration built into the planned SBCT battle rhythm.<sup>12</sup> The baseline light infantry brigade had a similar battle rhythm, but in the SBCT these meetings are much improved because of the quality of information available to the participants, the shared awareness of the situation made possible by the use of ABCS during the collaboration meetings, and the improved means of interaction using the network. These improvements are enabled by the use of ABCS and large screen displays during these meetings, so all participants in the meeting have access to the same rich set of information. Instead of focusing discus-

**Figure 6.10**  
**SBCT Battle Rhythm**

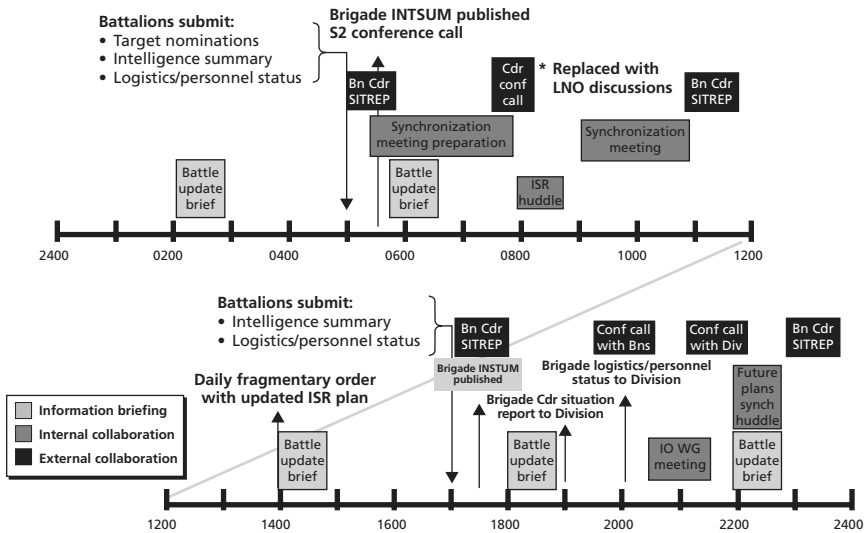

SOURCE: SBCT tactical standard operating procedures, March 2004.

RAND MG267-6.10

<sup>12</sup> The RAND research team observed a portion of the entire battle rhythm illustrated in Figure 6.10.

sion on the base levels of knowledge and comprehension of the situation, these interactions in the SBCT were observed to reach the higher levels of analysis and application. In other words, instead of spending most of the time trying to understand the location and status of friendly and enemy forces, leaders in the SBCT spend more time analyzing the situation and developing more effective courses of actions to defeat the enemy force. The RAND research team observed the SBCT synchronization meeting during a Home Station exercise and directly observed the above mentioned collaboration capabilities.

The Brigade Synchronization Meeting is one example that shows the improved quality of interaction in the SBCT. This is a key collaboration event for both the light infantry brigade and the SBCT. The ultimate goal of the meeting is to synchronize combat maneuver, support, and service support to achieve complementary and reinforcing effects to defeat the enemy. In the baseline meeting, the brigade staff and subordinate unit liaison officers arrive with their vastly different understandings of the situation based on limited accurate information, receive a briefing of the friendly and enemy situation using a map, and then wargame interaction with the enemy to identify tasks for friendly forces to synchronize combined-arms effects during the next 24–48 hours. In the SBCT meeting, the participants arrive with a much-improved shared understanding of the situation, access the ABCS to have real-time accurate understanding of the situation during the planning meeting, and conduct wargame interactions with the enemy to identify tasks for friendly forces to synchronize combined-arms effects. The key differences are that time available for planning is better spent and that planning is based on a more accurate starting point, so future plans are more likely to be relevant and effective. The product of the SBCT synchronization meeting is an order that is easily understood and executable by subordinate units based on shared anticipatory awareness.

Interviews with experienced soldiers reveal that Stryker soldiers believe this meeting is very worthwhile because the participants come prepared with quality information and shared awareness of the situa-



tion. Complete ABCS quality information and digital tools are available to the planners, keeping them grounded in current reality. They can rapidly go through MDMP steps issue by issue to define the problem; generate, analyze, and compare solutions; and capture that guidance for subordinate units. This process demonstrates the synergy gained between net-centric operations and net-centric planning. Developing this shared anticipatory awareness turns current operations “crisis management” into “exploiting opportunities” by arranging the right forces in time and space to achieve the desired effects and maintain faster tempo of operations.

Summarizing our assessment of the quality of interactions and collaboration (i.e., the two NCO concepts shown in Figure 2.5), 80 percent of Stryker soldiers surveyed believed their digital resources supported simultaneous battle tracking and battle planning by command posts, according to the operational evaluation survey. Eighty-six percent of Stryker soldiers believed ABCS facilitated better battlestaff decisionmaking than in nondigital baseline units. These results are shown in Figure 6.11.

## **Quality of Shared Awareness and Understanding**

The challenge with comparing the degree of shared awareness and understanding is describing how poor this was in a baseline unit for those who have not experienced analog combat.

In the light infantry brigade, each leader estimated his own and enemy locations by land navigation techniques. Widely different spot reports about friendly and enemy locations are sent via FM radio to higher headquarters. Because no post-and-retrieve capability resides on these voice nets, leaders may miss important information from monitoring two nets simultaneously. Occasionally, the TOC would issue an integrated operations or intelligence summary report, but the information was often wrong and still difficult to translate to multiple

**Figure 6.11**  
**Quality of Interactions—Operational Evaluation Surveys**

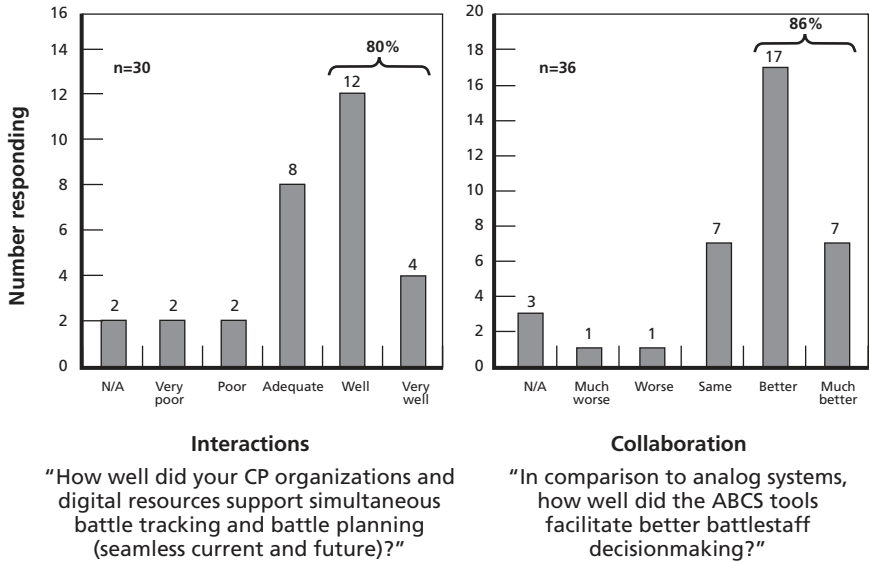

SOURCE: Army OECG survey of SBCT personnel.  
 RAND MG267-6.11

paper maps. The bottom line: there is no COP in the baseline, which results in a very low level of shared awareness and understanding.

In contrast, ABCS provides each leader in the SBCT with a COP containing relatively accurate and timely information about friendly and enemy forces. This COP represented by the MCS screen shot in Figure 6.12 easily facilitates shared awareness. Achieving shared understanding of the situation is much improved, but this cognitive step still requires analysis and trained, experienced judgment.

The SBCT uses the Command Information Centers (CIC) at brigade and battalion levels as the primary tool to build shared awareness and understanding within the command posts and among members of the unit. Depicted in the photograph in Figure 6.13 are

**Figure 6.12**  
**SBCT COP in MCS**

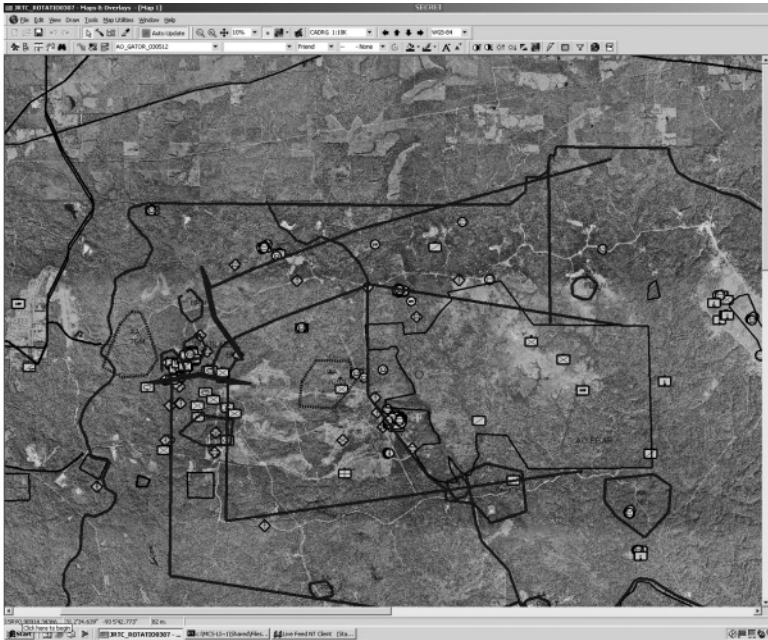

RAND MG267-6.12

the various information displays that represent the COP. However, it is important to understand that the COP is not automatically generated via the fusion of sensor feeds. It is the product of significant cognitive processing and knowledge creation by the entire staff and leaders in the field. The light infantry brigade has no equivalent CIC.

The left display is a live feed picture of friendly force elements provided by FBCB2. The display is updated every few minutes and shows the real-time location of all vehicles equipped with FBCB2/EPLRS. Shown also on this display are the various reports and battlefield graphics that can be transmitted via FBCB2 to and from subordinate force elements. Only the FBCB2 display is truly automated.

**Figure 6.13**  
**SBCT CIC**



RAND MG267-6.13

The center set of composite displays provide a summary of knowledge products generated by various staff elements. These include the operational and logistics status of each subordinate force element, the status of various critical information requirements and requests, a summary of the brigade's current mission and commander's intent, a summary of the brigade's synchronization matrix, the brigade's log of significant events, and a rolling PowerPoint presentation of the battlefield update briefing. This system manages the critical information the brigade needs to know to win the fight.

The right display is a second view of the battlefield provided by MCS, which performs two critical functions for the Stryker brigade. First, it provides a consolidated picture of enemy forces that have been prepared by the S-2. While the Army's ASAS is used within the military intelligence company to consolidate and analyze incoming reports on enemy forces, it is MCS-Lite that is actually used to display the resulting enemy picture to the rest of the brigade. Second, it provides various operational overlays that have been developed by specific staff sections.

Another valuable tool used to build shared awareness and understanding in the SBCT are digital military overlays in FBCB2 and MCS. Military overlays are the pictures that build the COP and accompany the text of operation orders; they are used to understand the situation and the plan. In the light infantry brigade, overlays were reproduced by hand, copied individually onto acetate, and displayed on distinct paper maps—an extremely cumbersome process that was inaccurate, untimely, and largely irrelevant.

Table 6.4 lists the different combinations of functional and situational awareness overlays specified for supporting different areas of battle management in the Stryker brigade. They represent a significant amount of cognitive reasoning by trained and experienced staff sections. Each overlay may be displayed individually or in groups to facilitate shared understanding within the command post. Each

**Table 6.4**  
**SBCT Digital Overlays**

<b>Battle Management Area</b>	<b>Functional Overlays</b>	<b>Situational Awareness Overlays</b>
Current operations	Brigade maneuver overlay Obstacle/survivability overlays Fire support–target overlay	FBCB2 live feed Correlated Red picture Blue units (JCDB overlay)
Reconnaissance battle	ISR overlay (NAI/TAI) Red situation overlays (templated units, obstacles) Obstacle overlays (planned executed)	FBCB2 live feed Correlated Red picture Reconnaissance units (JCDB unit overlay)
Fire support	Brigade maneuver overlay Fire support–FASCAM overlay Fire support–target overlay Fire support–range fan overlay Air control measure overlay Obstacle/survivability overlay	FBCB2 live feed Correlated Red picture Blue units (JCDB unit overlay)
Rear battle	Brigade maneuver overlay CSS route overlay CSS supply point overlay Obstacle/survivability overlay Medical point overlay	FBCB2 live feed Correlated Red picture Blue units (JCDB overlay) Reconnaissance units (JCDB overlay)

NOTE: NAI: Named Area of Interest; TAI: Target Area of Interest; FASCAM: Field Artillery Support Command; JCDB: Joint Common Database.

overlay can be instantly shared with the subordinate battalions and individual vehicles to enable shared understanding throughout the brigade. Sharing digital overlays is key to sharing understanding of new fragmentary orders and ultimately increasing the speed of command and force agility. These pictures help make sense of the commander’s words, presumably faster.

Shared awareness in the SBCT during the operational evaluation is depicted in Figure 6.14. Seventy-nine percent of Stryker soldiers surveyed believed ABCS was more effective in enabling the battlestaff to see the battlespace, and 72 percent of Stryker soldiers believed ABCS helped them analyze and fuse information, with 50 percent describing that process as “faster.” It is still harder to share under-

**Figure 6.14**  
**Quality of Shared Awareness and Understanding—Operational Evaluation Surveys**

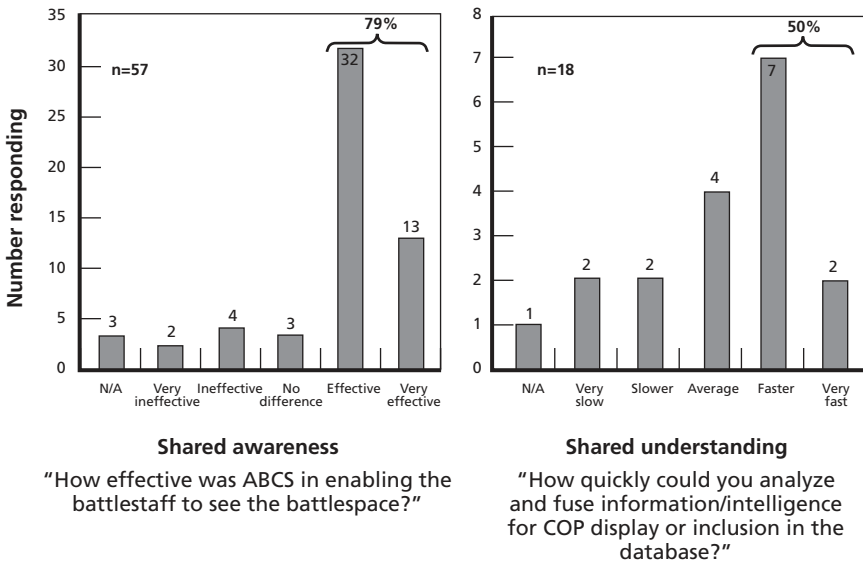

SOURCE: Army OECG survey of SBCT personnel.

standing than it is to share awareness of the situation. Training and experience remain essential to analyzing and understanding situations in land warfare. Nonetheless, the results suggest there is a significant improvement compared to the baseline light infantry brigade.

## Agile Decisionmaking and Self-Synchronization

The SBCT demonstrated improved speed of command, creating better decision options, self-synchronization, force agility, mission success, and survivability.

The SBCT demonstrated improved speed of command as shown in Figure 6.15. A time line of key events for this particular light infantry brigade (rotation used as the baseline in this analysis) is

**Figure 6.15**  
**Speed of Command: SBCT Compared to the Baseline**

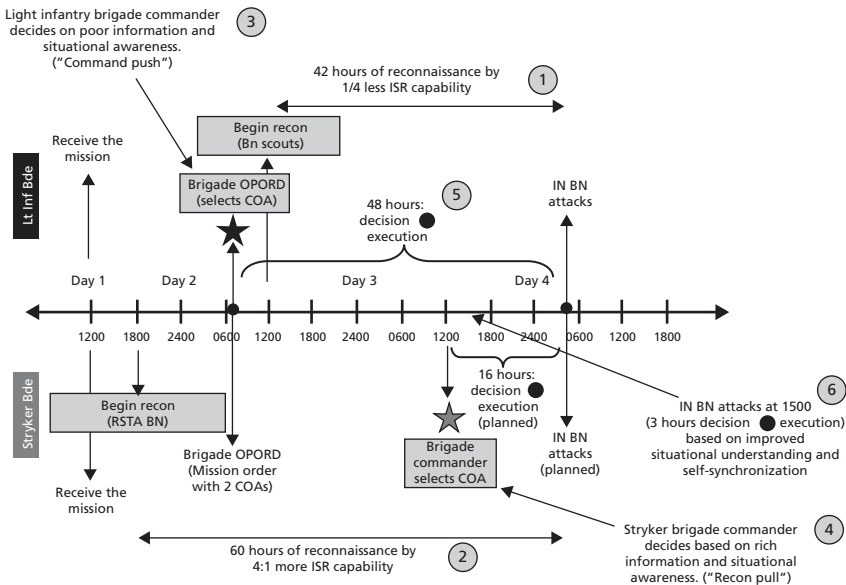

shown at the top in black, and the SBCT timeline is shown at the bottom in italics.<sup>13</sup> Both units receive the mission at the same time (1200 on Day 1) and have the same “No Later Than” time to attack (0400 on Day 4). The first difference concerns reconnaissance. The light infantry brigade had only 42 hours to conduct reconnaissance with one-quarter the number of reconnaissance platoons available to the SBCT. Because it has no brigade-level reconnaissance capability, a light brigade must task battalion scout platoons to support brigade reconnaissance objectives. However, the light brigade must take the time to develop and approve a course of action before tasking battalion scout platoons to observe brigade named areas of interest (NAI) within their battalion zone of operations. The SBCT began reconnaissance with the RSTA squadron only six hours after receiving the mission, achieving 60 hours of reconnaissance with four times more reconnaissance platoons. The importance of the RSTA squadron in brigade operations must not be underestimated. What does this mean? It means the light infantry brigade selected its course of action and issued a detailed operational order at 0600 on Day 2, before it gained situational awareness of the enemy. This is an example of a “command push” operation. In contrast, the SBCT issued a mission order with two possible options for employment at the same time, but delayed selection of the course of action until it gained situational awareness of enemy forces. This is an example of a reconnaissance-pull operation. The speed of command in the particular light infantry brigade rotation used as the baseline in this analysis was constrained by the doctrinal “one-third to two-thirds” rule to leave two-thirds of time available (48 hours) from decision to execution so subordinate units could plan, prepare, reconnoiter, and rehearse operations. The SBCT planned to leave 16 hours time from decision to execution, but in fact attacked only three hours after the brigade selected its course of action to exploit an opportunity and surprise the enemy.

---

<sup>13</sup> These event time lines were compiled from exercise data made available to RAND for the SBCT CERTEX and a typical light infantry brigade rotation.



This demonstrates a significant improvement in speed of command and in both command and force agility over the baseline.

The NCW capabilities in the SBCT actually afford the commander greater control of the speed of command. He can decide to act faster to maintain tempo and retain the initiative or he can delay selection of a course of action to conduct reconnaissance and shaping operations based on which affords him the greatest tactical advantage. On the particular rotation examined, the light infantry brigade was a “prisoner” of the “one-third to two-thirds” rule because of the time required for planning and distributing detailed paper orders to subordinates and conducting battalion reconnaissance, the difficulty sharing understanding of the plan, and the requirement to rehearse planned force synchronization. Typically, if the baseline violates the one-third to two-thirds rule to make informed decisions, it pays a price measured in loss of shared understanding of the plan and force synchronization because it lacks the cultural and network capabilities to support agile battle command.

The Stryker brigade made more effective use of the time available through abbreviated collaborative planning, sending digital mission-type orders, conducting effective brigade reconnaissance, sharing understanding of the situation, and as shown below, fielding agile, self-synchronizing infantry battalions. During the Shughart-Gordon attack, these NCW capabilities allowed the Stryker brigade to make, communicate, and implement better decisions faster than the enemy—the definition of decision superiority.

One example of improved self-synchronization and tempo during the Shughart-Gordon attack facilitated by NCW capabilities was this decision to attack early. The RSTA squadron successfully identified enemy forces in the disruption zone and in Shughart-Gordon. The lead infantry battalion bypassed enemy forces in the disruption zone and quickly isolated the objective. The main-effort infantry battalion planned to attack at 0400 on May 25, but actually attacked at 1500 on May 24—13 hours early.

Looking at the MCS display shown in Figure 6.16, the infantry battalion commander said,

I could see [on the COP] the lead battalion had accomplished its mission early. I moved up our attack time to maintain momentum.

The shared situational understanding resident in the COP contributed to better collaborative decisionmaking, self-synchronization, and increased tempo.

NCW capabilities provided early and clear decision options to the SBCT. When the enemy has the information and advantage, the light infantry brigade selected the axis of advance before gaining situational awareness, made contact in the disruption zone, and attempt-

**Figure 6.16**  
**MCS Screen Shot: Day of Attack**

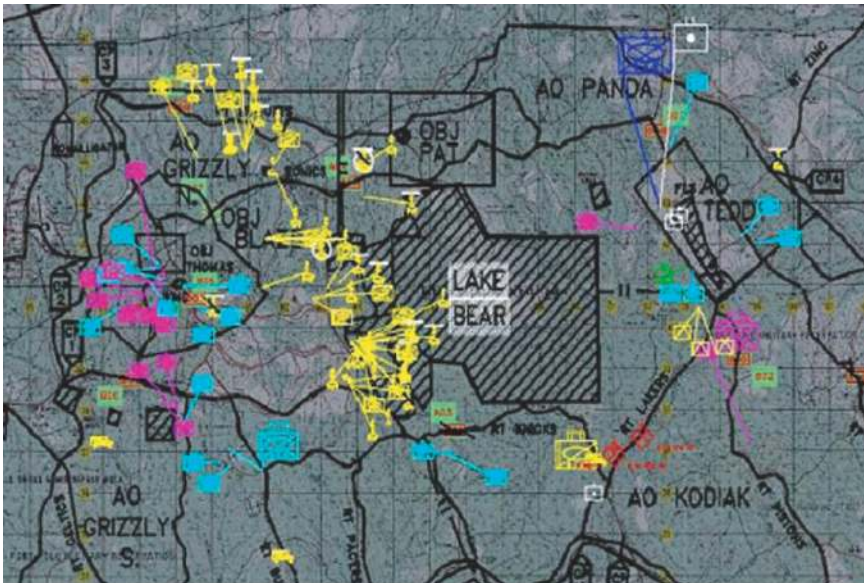

ed to develop the situation. It rarely gained situational understanding until the after-action review. Agile enemy forces retained the initiative while friendly forces continued to fight the plan. Ultimately, the enemy massed effects of combat power to defeat the brigade in detail, most often resulting in mission failure. In contrast, the SBCT first gained more complete, accurate, and timely situational awareness. Leaders understood the enemy defense and selected the best avenues of approach to attack the least defended areas from a position of advantage as shown in Figure 6.17.

Agile friendly forces seized the initiative by attacking early and rapidly, achieved surprise, and maintained the tempo of the attack by continuously synchronizing complementary and reinforcing effects. The observer controllers watched the OPFOR fall for the deception plan and move forces to the wrong place, only to be violently attacked from an unexpected direction. Ultimately, the Stryker brigade destroyed the enemy force, cleared every building at Shughart-Gordon, and defeated enemy counterattacks. In the end, the battal-

**Figure 6.17**  
**Better Decision Options**

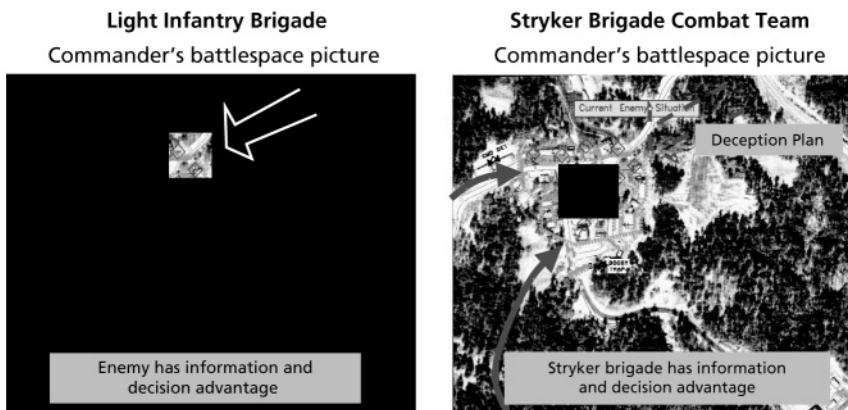

ion commander said it best, “We had a great read by RSTA confirmed by UAV. We selected the best avenues to attack the least defended areas.”

## Force Effectiveness

The SBCT demonstrated improved mission accomplishment and survivability. Ninety-five percent of Stryker soldiers surveyed expressed increased confidence in the unit’s ability to accomplish its mission. An observer controller at the JRTC made the following comments, using the operational concept depicted in Figure 2.5:

- “See First: The Stryker brigade used assets like UAV and Stryker [reconnaissance vehicle] with the ability to see first. The [brigade] was not able to get eyes on everything, but it definitely provided a see-first concept better than any other [brigade] rotation.
- “Understand First: FBCB2 when populated shows the location of the Blue forces and the enemy’s in almost real time providing [situational awareness] to all leaders. FBCB2 made [situational awareness]and [situational understanding] seem like second nature to the Stryker brigade.”<sup>14</sup>

He also added that:

- “Act First: With the assets provided to the Stryker brigade, they no longer have to wait for the info, it’s already there. This allows the [brigade] to act immediately, catching the enemy by surprise, which was demonstrated successfully at the attack at Shughart-Gordon.

---

<sup>14</sup> *Senior Observer Controller Summary*, SBCT Operational Evaluation Database, May 2003.

- “The most impressive capability demonstrated by the SBCT was the ability to affect the enemy’s decision cycle through [situational awareness and situational understanding] combined with mobility and lethality. The best example of this was during the Shughart-Gordon urban attack operation.
- “The [situational awareness and situational understanding] afforded platoon leaders and commanders by the lower [tactical internet] and FBCB2 [gave them] the ability to maneuver their forces and close with and destroy the enemy during urban operations in Shughart-Gordon.”<sup>15</sup>

The ratio of friendly to enemy casualties during the Shughart-Gordon attack improved from 10:1 in a baseline light infantry brigade to 1:1 in the SBCT against the trained OPFOR in urban combat. An observer in the Operational Evaluation Control Group remarked, “Observing 24 rotations of the Shughart-Gordon attack, I have never seen a unit clear every building and retain combat power to defeat the enemy counterattack.” NCW capabilities contributed to this significant increase in force capability.

---

<sup>15</sup> *Senior Observer Controller Summary*, SBCT Operational Evaluation Database, May 2003.



## Conclusions

---

The Army has made a substantial effort to equip the Stryker brigade unit with an integrated set of digital battle management C2 capabilities (i.e., a digital communications network with integrated battle command systems that support its new force design, its new organizational structure, and its new operational concept). We found the Army's force design and systems integration efforts to be largely successful.

The SBCT utilizes a concept of operations that emphasizes information-sharing with elements that bear a striking resemblance to some of the concepts found in NCO theory—as defined in the NCO CF developed by OFT and OASD (NII).<sup>1</sup> The Stryker brigade's embedded RSTA capabilities, organic military intelligence company, and other features enable it to generate its own high-quality situational awareness information.

The Stryker brigade is equipped with current-generation Army digital terrestrial and satellite communications systems and evolving battle command systems. Many of these systems have been fielded in other digitized heavy armor units in the Army. The Stryker brigade, with an organizational structure that has been tailored to accommo-

---

<sup>1</sup> The NCO CF is described in Signori et al. (2002); Evidence Based Research, Inc. (2003); and Signori et al. (2004). Major concepts of NCO are described in Alberts, Garstka, and Stein (1999) and Alberts and Garstka (2001).

date these new digital systems, can rapidly generate, share, and act on situational awareness information.

## Objective

The objective of this study was twofold: to understand whether NCO capabilities are a source of combat power for the Stryker brigade and to determine the extent to which the tenets of the NCO hypothesis can be realized by this unit.

The original NCW hypothesis posits the following relationships between twenty-first century information technologies, information sharing, and warfighting capabilities:

- “A robustly networked force improves information sharing
- Information sharing enhances the quality of information and shared situational awareness
- Shared situational awareness enables self-synchronization, and enhances sustainability and speed of command
- These, in turn, dramatically increase mission effectiveness.” (Alberts and Garstka, 2001.)

We have examined inference chains of the NCO hypothesis and the NCO CF from the context of the Stryker brigade doctrine. Our investigation reveals the Stryker brigade has been designed with NCO capabilities in mind and is essentially an NCO-enabled MCP (Alberts, 1995).

## Study Scope and Context

It is worthwhile to review the scope of this study before summarizing the results. The scope and context for this study are in part determined by the original strategic mission context defined for the Stryker brigade by the Army when it was created several years ago.



We must provide early entry forces that can operate jointly, without access to fixed forward bases, but we still need the power to slug it out and win decisively. Today, our heavy forces are too heavy and our light forces lack staying power. We will address those mismatches. (Shinseki, 1999.)

General Shinseki, the former Army Chief of Staff, recognized the need for a new medium-weight force capable of independent ground maneuver operations. His vision led to the creation of the Stryker brigade.

The Stryker brigade and the Stryker wheeled vehicle were designed to be rapidly deployable by airlift and sealift. These vehicles were designed to enable a light infantry force to maneuver rapidly on the battlefield to positions of tactical advantage.

The Stryker brigade and the Stryker combat vehicle are still controversial. The focus of this particular study was not on the vehicle and its capabilities or limitations. Rather it is on the information or NCO capabilities of this unit.

As already discussed in this report, we selected the closest predecessor unit to the SBCT to be a light infantry brigade. Consequently, the baseline unit we compared the Stryker brigade to was a light infantry brigade in an SSC scenario.

Some of the key reasons we compared the Stryker brigade to a nondigitized light infantry brigade are the following:

- The SBCT conducted a structured CERTEX at JRTC. This provided us the best possible available data regarding the SBCT's use of NCO capabilities.
- We wanted to control for other factors, such as the type of scenario, the enemy composition, and the type of terrain, and therefore wanted to look at the SBCT vis-à-vis other units that conduct JRTC rotations—e.g., light infantry brigades.
- Both the SBCT and light infantry brigades train at SSC scenarios at the JRTC, and the SBCT is tailored for conducting operations in SSCs.

- The SBCT was originally designed to sometimes replace light infantry brigades in rapid deployment missions where greater mobility and firepower is necessary. Thus, we decided that comparing the SBCT to the organization it could replace (light infantry brigades) for some operations was best.
- The Marine Expeditionary Brigade has light infantry vehicles, but the organization, doctrine, training, and materiel factors are significantly different from those employed by the Stryker brigade.

The specific scenario we utilized as the point of comparison is one used at operational evaluations of light infantry brigade units at the JRTC for several years. We focused on the culminating tactical engagement such units execute at the JRTC during their operational evaluation: the brigade attack at the Shughart-Gordon urban training site.

The Stryker brigade JRTC scenario was more stressing in some respects for the Stryker brigade than has been typically encountered in the past at the JRTC by light infantry brigades. As a light infantry brigade would be, the Stryker brigade was called on to rapidly deploy into contested territory, become combat ready quickly, rapidly maneuver once on the ground, and engage in offensive operations against an enemy light infantry force holding a key objective—the city of Shughart-Gordon. In contrast, unlike a light infantry brigade, the Stryker brigade was tasked to execute additional simultaneous offensive, defensive, stability, and support operations in several other noncontiguous areas.

## Findings

We found the Stryker brigade to be a significantly more agile and capable combat force than its closest predecessor unit in a similar CERTEX at the JRTC.

Our analysis reveals that several key NCW factors contributed to an order of magnitude increase in the Stryker brigade’s force effectiveness in the JRTC CERTEX.

The key NCO materiel improvements were:

- 75 percent or more of SBCT combat vehicles have networked battle command systems.<sup>2</sup>
- High-bandwidth beyond-line-of-sight SATCOM links are used to connect brigade- and battalion-level C2 centers.

These SBCT NCO materiel enhancements, along with the other nonmateriel factors that define the SBCT MCP, result in the significant improvements shown in Table 7.1. It is important to note that Stryker brigade doctrine is designed to exploit these NCW capabilities. The result for the Stryker brigade in its CERTEX was a significant improvement in force effectiveness and survivability, as illustrated in Table 7.1.

The following comments by JRTC observer controllers who witnessed the SBCT CERTEX corroborate our assertion that the

**Table 7.1**  
**Improved Mission Accomplishment and Survivability**

	<b>Light Infantry Brigade</b>	<b>Stryker Brigade</b>
Quality of individual and shared information <sup>a</sup>	~10%	~80%
Speed of command	48 hours	3 hours
Ability to control the speed of command	No	Yes
Blue:Red Casualty Ratio	10:1	1:1

<sup>a</sup>“Quality of situational awareness information” is defined as the percentage of actual enemy, neutral, and friendly forces that are correctly identified and accurately located by the commanders and soldiers or by their information system in each unit.

<sup>2</sup> Note that the percentage of Stryker combat vehicles equipped with networked battle command systems in the brigade is now higher than 75 percent.

SBCT's NCO capabilities made a significant contribution to the increase in force effectiveness observed.

The most impressive capability demonstrated by the SBCT was the ability to affect the enemy's decision cycle through [situational awareness/situational understanding] and combined with mobility and lethality. The best example of this was during the Shughart-Gordon urban attack operation.<sup>3</sup>

The [situational awareness/situational understanding] afforded platoon leaders and commanders by the lower [tactical internet] and FBCB2 [gave them] the ability to maneuver their forces and close with and destroy the enemy during urban operations in Shughart-Gordon.<sup>4</sup>

Observing 24 units attack Shughart-Gordon as a JRTC [observer controller], I have never seen a unit clear every building and still retain combat power to defeat an enemy counterattack.<sup>5</sup>

Therefore, we conclude that the SBCT has demonstrated some of the benefits NCW capabilities can provide to U.S. ground forces. Further, we can conclude that, at least in the tactical engagement observed at the SBCT CERTEX, the Stryker brigade NCW hypothesis has been confirmed.

## Comparison of Exogenous Factors

We reviewed the composition of the OPFOR employed in a typical light infantry brigade rotation at the JRTC and the OPFOR at the Stryker brigade CERTEX. We found no significant difference in the OPFOR during the SBCT attack at Shughart-Gordon. The OPFOR

---

<sup>3</sup> JRTC senior observer controller comments.

<sup>4</sup> JRTC senior observer controller comments

<sup>5</sup> Comments of a senior JRTC observer controller in the OECG.

defended Shughart-Gordon as described earlier in this report, with two platoons in the city, one platoon in the immediate area, and two company-size groups in the wider disruption zone. JRTC observer controllers reported this to be a “close to the same” composition and disposition of the OPFOR during a typical light infantry brigade attack. The OPFOR in both rotations had the same number of RPGs. However, it is important to note that for the Stryker brigade rotation the JRTC had just changed from the old Soviet/Krasnovian threat template to the new TRADOC Contemporary Operating Environment (COE) threat template (all units going through the JRTC now use the new threat template). For example, the new OPFOR had 20 percent fewer antitank mines because the new enemy relied less on deliberate defense and firepower but more on unpredictable and asymmetric attacks. This new enemy is actually more challenging because fewer constraints are placed on OPFOR actions.

We also reviewed the intelligence information provided by the division to the Stryker brigade at the SBCT CERTEX. We found no significant or undue advantage given to the Stryker brigade in its CERTEX by this division representation. It is worth noting a few points with regard to intelligence support provided to the SBCT.

The SBCT has an organic military intelligence company; the light infantry brigade does not. Therefore, to ensure the SBCT S-2 and military intelligence company received maximum training benefit and exercised its reach-back and network capabilities, the JRTC and I Corps formed a Division Intelligence Support Element (DISE) for the military intelligence company to interact and collaborate with. This is a change from a light brigade rotation, but it simply reflects the SBCT's added capabilities. Information provided from the DISE was closely controlled by JRTC OECG and reflected the division intelligence summaries that we reviewed. Based on this review, we can confirm that the SBCT still achieved its high level of real-time situational awareness primarily using its own organic RSTA capabilities.

## Caveats

Some important caveats that apply to these results should be kept in mind. First, this was a case study and so by its very nature was not a repeatable experiment. We considered only one case—one SBCT rotation at the JRTC and one tactical engagement—the attack at Shughart-Gordon that light infantry units have been trained on for years. Nevertheless, we believe this is a good “data point,” as this JRTC vignette is carefully designed and was observed by experienced observer controllers.

Second, many factors contributed to the success of the Stryker brigade, such as the Stryker vehicle’s mobility that allowed the infantry soldiers to arrive fresh for battle instead of walking 25 kilometers while fighting enemy forces in ambushes in difficult terrain. The mobility of the Stryker vehicle also provides the SBCT the speed and agility to rapidly respond to changes in the battlespace represented in the COP. The Stryker vehicle also delivers more firepower than light infantry units typically have. However, it is not clear that this firepower was a dominant or even an important factor in the engagement. We do know that the vehicle was used effectively as protection against enemy fire. In this study, it was not possible to isolate the observed increase in force effectiveness to a single variable—the capabilities of the information network. It is not possible with the data available to isolate and quantify the contribution of the information component of the units to the overall force effectiveness of the SBCT. Thus, we attribute this improvement to the entire MCP.

Finally, an additional caveat obtains with regard to the data on which this study is based. In this particular case study, we had access to data from multiple and in some cases dissimilar sources for the different units whose performance we assessed. This study was also conducted under tight timelines to meet the sponsor’s needs, which prevented us from carefully designing data collection strategies and scheduling data collection opportunities with specific units. Because of this, we had to make the best possible use of data already available from recent exercises in which light infantry or Stryker brigades had

participated. In addition, because of this, we compiled interview data taken from independently conducted surveys of unit commanders for different exercises. We did not have control over the data collection approaches used in these prior studies or operational evaluations. Nevertheless, we made every effort to ensure that data collected from different exercises and dissimilar sources were used in a credible and analytically correct fashion.

## **Proposed Enhancements to the NCO CF**

During the course of this case study, we discovered several factors that contribute to the overall NCO capabilities of the Stryker brigade that we believe are not adequately reflected in the current NCO CF. We describe some of these factors and the need for additional classes of NCO capability performance metrics in this chapter.

First, operations within the SBCT suggest that the “Quality of Organic Information” is not confined to the information domain. As discussed in earlier figures, the enemy forces’ picture within the brigade is built by the brigade S-2 and experienced analysts residing within the attached military intelligence company. With the exception of the FBCB2 live-feed display, the majority of the brigade COP reflects the product of human sense-making, not automated sensor fusion. Accordingly, additional metrics should be developed that reflect the degree to which the development, maintenance, and sharing of the COP critically depends on the interaction of technology, training, and personnel experience.

The current NCW framework does not address the synergy between net-centric current operations and improved planning in land warfare. Net-centric operations improve the quality and relevance of planning by providing complete, accurate, and timely shared awareness to the operational planning team; increasing multiechelon collaboration between commanders and staffs; providing the unit a battle command network to make, communicate, and implement

plans quickly; and developing agile leaders and units that can execute flexible mission orders to fight the enemy. In turn, net-centric planning improves current operations by developing and sharing high-quality anticipatory or predictive awareness of future operations; preparing relevant contingency plans based on realistic friendly-enemy interaction; turning “crisis management” into “exploiting opportunities” through prior preparation; and arranging forces in time and space effectively to achieve the desired effects. Far from making planning unnecessary, it is our hypothesis (and one which we believe is at least partially confirmed by the SBCT) that robust NCW capabilities can make planning more effective and relevant in land warfare.

Our experience in the Stryker brigade case study indicates that the “Quality of Interactions” element within the NCO framework does not adequately capture the importance of reengineering the MDMP. The MDMP is about more than just shared sense-making. Rather, it is about how commanders adjust their planning process to manage uncertainty and risk (produced by the fog and friction of warfare) while providing maximum agility. The availability of RSTA assets (an RSTA squadron) and FBCB2 provides for both enhanced situational awareness and (with proper training) enhanced situational understanding within the SBCT. This, in turn, has allowed the brigade to move from a traditional deliberate planning process to one that is highly adaptive and fully exploits enhanced situational awareness and understanding. This is not an incremental improvement. Instead, we believe it reflects a quantum leap forward to a new type of planning and decisionmaking strategy. The Stryker brigade has focused on reengineering the process, procedures, training, and leadership thinking to make this a reality. Accordingly, additional metrics are required to reflect the degree to which the MDMP has been properly reengineered to exploit the potential advantages of information networks in combination with other types of unit enhancements (e.g., RSTA, mobility, lethality).

Finally, “shared sense-making” is a performance area influenced by more than just the social domain. Many factors were seen to influ-



ence collaboration and the sharing of knowledge across the SBCT. These included communication bandwidth restrictions, leader and staff training, and the dynamics of the battle rhythm that place workload and time constraints on key leaders at each echelon. It was also seen that shared sense-making can be significantly influenced by third parties. Specifically, the ability of trained and experienced staff personnel at the brigade level to push tailored intelligence products, terrain products, and other key pieces of information down to lower echelons at key points in the operation was seen to impact directly on the ability of the battalions and companies to collaborate horizontally and self-synchronize. Accordingly, additional metrics are required to reflect the degree to which process design, technology, business rules (e.g., synchronization meeting agenda), training, personnel experience, and other factors combine to either enhance or impede effective and efficient collaboration.

## **Implications for the Future**

There is reason to believe current results for the SBCT may underestimate the potential of more robust NCW capabilities in future land warfare. The current Stryker brigade information network is based on legacy communications systems that supply limited bandwidth and have limited range on the battlefield (many TI links are terrestrial line-of-sight links that have limited range, especially in complex terrain or high-foliage environments). The limitations of the current Stryker brigade TI were noted at the JRTC. An interim solution for these shortcomings has been found for the Stryker brigade currently deployed in Iraq. This unit is now equipped with 11 SATCOM very-small-aperture terminals (VSATs) to reduce the brigade's reliance on vulnerable ground-relay sites and to enable parts of the brigade to operate at greater distances from one another consistent with the Stryker brigade operational concepts.

However, this short-term solution should not cause neglect of important long-term initiatives that can provide even more robust NCO capabilities in the future. The JTRS and the more capable and secure high-capacity SATCOM VSATs of the WIN-T program will significantly improve the networking and collaboration capabilities of future digitized Army forces, including those of the Stryker brigade.

Finally, the Stryker brigade may offer additional insight into what NCO capabilities can provide future Army forces. The organizational structure of the Stryker brigade was designed around a new information-centric operational concept. These new organizational and operational concepts may provide useful starting points for the operational concepts and organizational structures that will one day be used by future Army forces that will be equipped with the FCS.

APPENDIX A

**Director, Office of Force Transformation, Study  
Authorization Memorandum**

---

**Figure A.1**  
**Study Authorization Memorandum**

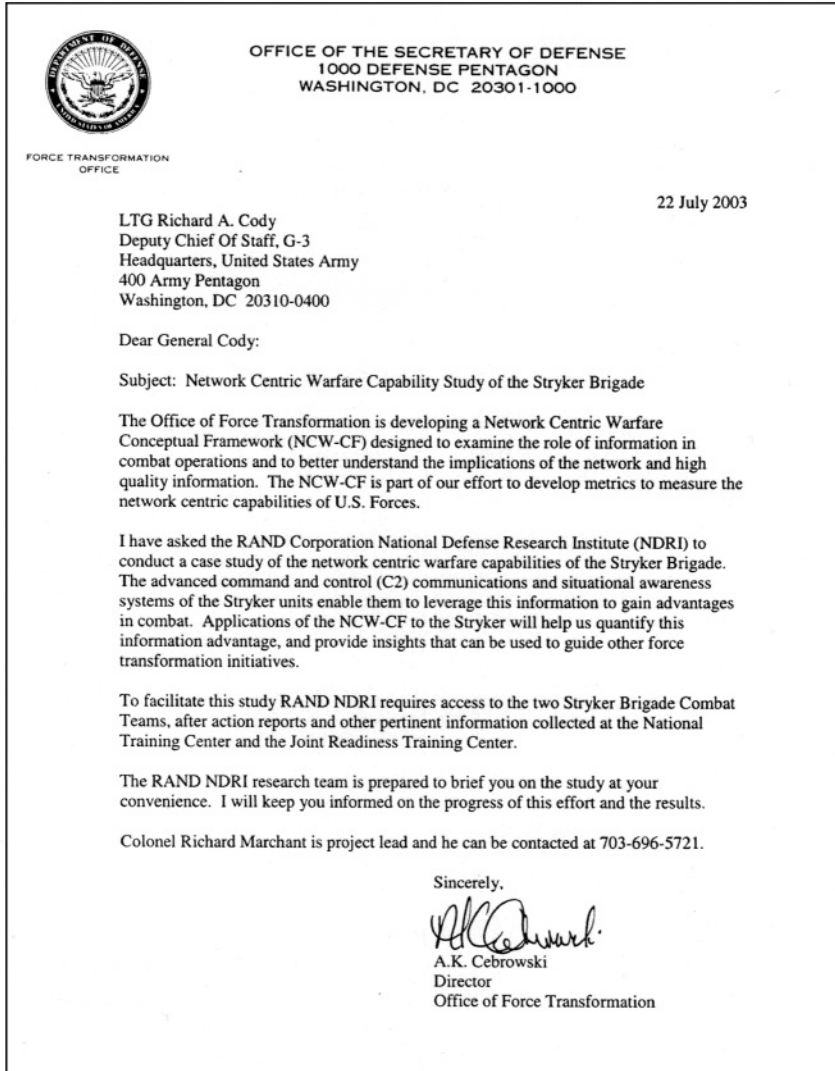

## Glossary

---

The glossary defines the major terms used in this report. In addition, we have included the source of the definitions. Where more than one source is given, the definition generally has multiple components and the order of the sources corresponds to the order of the definitions. In a few cases, definitions have undergone modifications. In these cases, both the original source (listed first) and the source of the modification are given.

Several abbreviations have been used in the list of sources. “Dictionary” is (Webster’s, 1998), “NCW” stands for *Network-Centric Warfare* (Alberts et al., 1999), “UIAW” stands for the book *Understanding Information Age Warfare* (Alberts et al., 2001), and “Workshop” stands for the presentation given to the NCW/NEC workshop (Signori et al., 2002). “RAND” definitions are intended to be illustrative only. They have not been reviewed by the sponsor and are subject to further refinement.

**Table B.1**  
**Glossary of Terms**

Term	Definition	Source
Agility	The force’s ability to operate effectively and efficiently under uncertainty; includes the force’s ability to provide a range of standard and novel options for success covering a range of missions, scenarios and conditions of degradation; comprises the attributes <i>robustness, responsiveness, flexibility, innovativeness, and adaptability</i> .	RAND

Table B.1—continued

Term	Definition	Source
Awareness	A comprehensive view of the battlespace that includes mission constraints; environment; time-space relationships; the capabilities and intentions of Red, Blue, and neutral forces; and an assessment of the associated uncertainties.	Workshop RAND
Decision	A choice made by an individual or group; a decision may be written and explicit or not.	UIAW RAND
Effectiveness	Achievement of mission objectives.	RAND
Extent of Sharing	Proportion of information, sense-making, or decisions in common across force members, within and across communities of interest.	Workshop
Fitness for Use Quality Measures	Subset of quality attributes that are dependent on mission context; applies to information, sense-making, and decisions; comprises <i>accuracy</i> , <i>completeness</i> , <i>relevance</i> , and <i>timeliness</i> .	RAND Workshop
Force	All elements and processes assigned, utilized, or deployed in support of a mission; may include one or more mission capability packages.	RAND
Individual Awareness	An individual's comprehensive view of the battlespace that includes mission constraints; environment; time-space relationships; the capabilities and intentions of Red, Blue, and neutral forces; and an assessment of the associated uncertainties.	Workshop
Individual Information	All information gathered by a force member, including <i>organic information</i> and <i>shared information</i> .	Workshop RAND
Individual Sense-Making	Consists of <i>individual awareness</i> and <i>individual understanding</i> .	Workshop
Individual Understanding	An individual's ability to extract meaning from a mental image; an individual's recognition of patterns, cause and effect relationships, dynamic futures, opportunities, and risks.	Workshop
Information "Share-Ability"	The ability to share information among force entities; dependent on the network's ability to accept, index, and transmit particular pieces of information, including data elements, data files, and streams of information quickly and accurately.	Workshop RAND
Information Sharing	Exchange of meaningful data and information (digital files, speech, gestures, etc.) between two or more force entities.	RAND

Table B.1—continued

Term	Definition	Source
Interactions	Mutual or reciprocal action between force members; any of a number of transactions between force members whether supported by the network or not; includes active exchange of data, information, knowledge, and collaboration; supported by <i>individual characteristics, organizational characteristics, and organizational and individual behaviors</i> .	Workshop
Mission Effectiveness	Measurement of the force's achievement of mission objectives.	RAND
Network	Connectivity between net-ready nodes, including the types of information they can share and under what conditions.	Workshop RAND
Network-Centric Warfare	An information advantage-enabled concept of operations that generates increased combat power by networking sensors, decisionmakers, and shooters to achieve shared awareness, increased speed of command, higher tempo of operations, greater lethality, increased survivability, and a degree of self-synchronization. In essence, NCW translates information superiority into combat power by effectively linking knowledgeable entities in the battlespace.	NCW
Networking	Force entities and their interconnections, including what types of information they can share and under what conditions; consists of <i>net-ready nodes</i> and their <i>network</i> .	RAND Workshop
Objective Quality Attributes	Subset of quality attributes that can be quantitatively assessed regardless of mission context; applies to Information, sense-making and decisions; comprises <i>correctness, currency, consistency, and precision</i> .	RAND Workshop
Organic Information	Information or data at the point(s) where it is first available to one or more force elements; information at its origin or source; see also <i>sources of information</i> .	Workshop RAND
Quality	Vector of attributes describing the quality of information, sense-making, or decisions; comprises <i>objective</i> and <i>fitness for use</i> attributes.	RAND
Self-Synchronization	Ability of a force to act in a manner coordinated in intent, time, and space with other battlespace entities, without being ordered to do so specifically; synchronization of force entities without direction from their commanders.	RAND
Shared Awareness	Aspects of awareness held in common by two or more force elements.	Workshop
Shared Information	Elements of information held in common by two or more force elements.	

**Table B.1—continued**

<b>Term</b>	<b>Definition</b>	<b>Source</b>
Shared Understanding	Understanding held in common by two or more force elements.	Workshop
Situational Awareness	See <i>awareness</i> .	RAND
Sources of Information	Nodes, including people and machines, that provide information; see <i>organic information</i> .	RAND
Synchronization	Purposeful arrangement of things in time and space; coordination in intent, time, and space; degree of synchronization determines whether plans and actions destructively interfere, have no interference, or mutually reinforce each other.	Dictionary UIAW RAND
Understanding	Ability to extract meaning from a mental image; recognition of patterns, cause and effect relationships, dynamic futures, and opportunities and risks.	Workshop RAND



## Complete List of Questions

---

### First Set of Questions

#### Stryker Brigade Mission Capabilities Package

- What are the most important changes in the Stryker Brigade O&O that increase your brigade's combat effectiveness?
- What do you think about the Stryker brigade's ABCS?

#### Quality of Individual Information

- Is the quality of information you receive complete and timely enough to achieve accurate situational understanding?

#### Quality of Interactions (Collaboration)

- How have you modified MDMP to conduct multiechelon collaborative planning?
- How do you, your staff, and your subordinate units collaborate during execution?

#### Quality of Shared Awareness and Understanding

- To what extent does your brigade staff and subordinate units share your situational understanding? Is that better than your experience in light infantry units?

- How well does ABCS integrate information to build a common tactical picture? Is that better than your experience in light infantry units?

#### **Decision Options/Speed of Command**

- How does ABCS allow you to make better decisions faster than the enemy?

#### **Force Agility**

- The Stryker vehicle obviously offers the SBCT greater mobility than a light infantry brigade, but in what other ways is the SBCT more agile?

#### **Force Synchronization**

- How does the ABCS allow the Stryker brigade to synchronize combined arms better than a light infantry brigade? For example, can you issue better fragmentary orders? Can your subordinates “self-synchronize” in accordance with commander’s intent due to their shared situational understanding?

#### **Force Effectiveness**

- Do you think the network-centric warfare capabilities of the Stryker brigade have increased your overall force effectiveness?

### **Second Set of Questions**

#### **Stryker Brigade Mission Capabilities Package**

- We would like to understand the real value added of the new organizations in the SBCT . . . did the cavalry squadron (RSTA battalion) and S-2/military intelligence company analysis allow you to see first, understand the enemy, and select the optimum axis of advance to maneuver decisively during the Shughart-

Gordon attack? Or did you make contact and develop the situation as usual?

- We are also trying to measure the utility of the ABCS information network . . . to what extent did ABCS network enable commanders, staff, and units to access and share more information? Was this important during the Shughart-Gordon attack? How does that compare to your previous experience in nondigital units?
- How does your information management system work to promote sharing of critical information and prevent information overload?
- What other operational concepts were you able to demonstrate during the JRTC CERTEX that you could not do in previous nondigital units? (e.g., mission orders, decision-point tactics, recon-pull operations, and maneuver-warfare)

#### **Quality of Individual Information**

- We would like to measure the quality of information that you received from ABCS during the Shughart-Gordon attack according to NCW metrics . . .
- Completeness: To what extent did you receive information relevant to ground truth in the following ABCS components? How does that compare to your experience in nondigital units? Use the figure to plot data points by battlefield operating system. Example (see Figure C.1):

**Figure C.1**  
**ABCS Information Completeness**

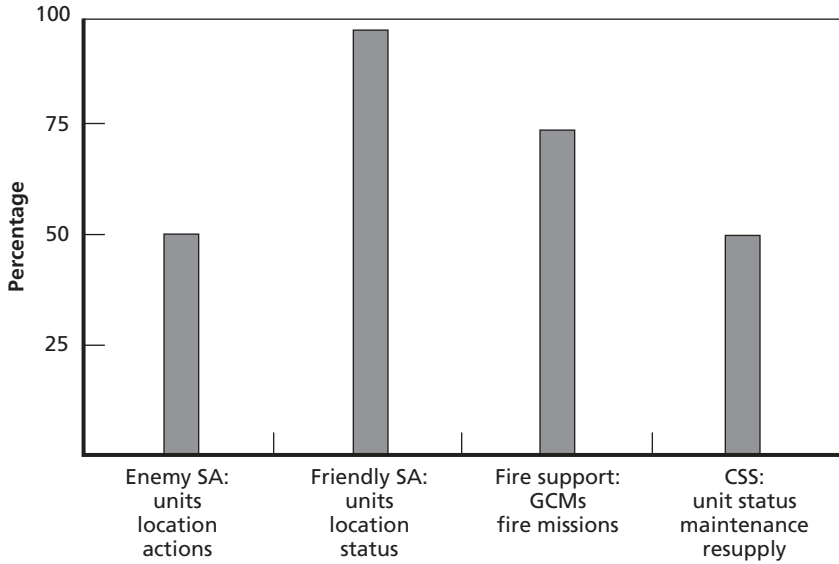

RAND MG267-C.1

- **Timeliness:** To what extent was your information current in the following ABCS components? How does that compare to your experience in nondigital units? Example (see Figure C.2):

**Figure C.2**  
**ABCS Information Timeliness**

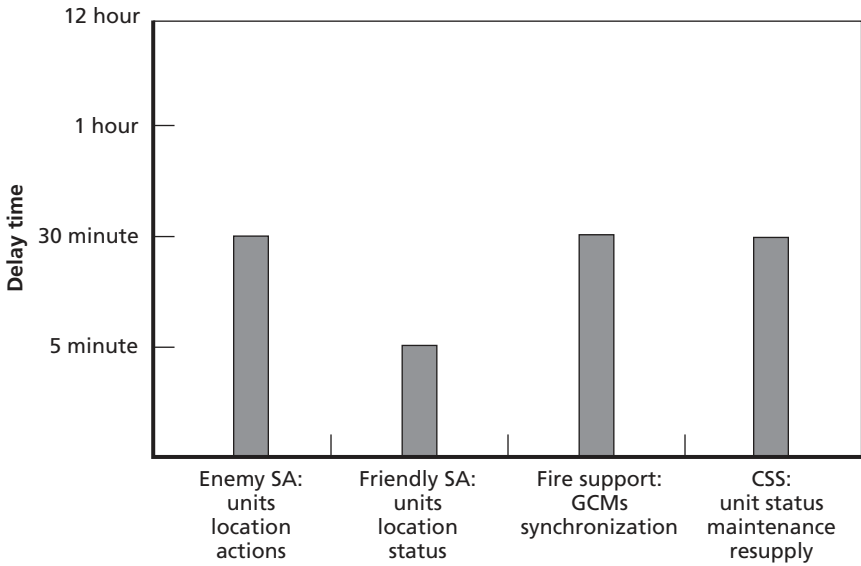

RAND MG267-C.2

- Accuracy: To what extent did you receive the accurate information necessary to answer your CCIR? How does that compare to your experience in nondigital units? Example (see Figure C.3):

**Figure C.3**  
**ABCS Information Accuracy and Relevance**

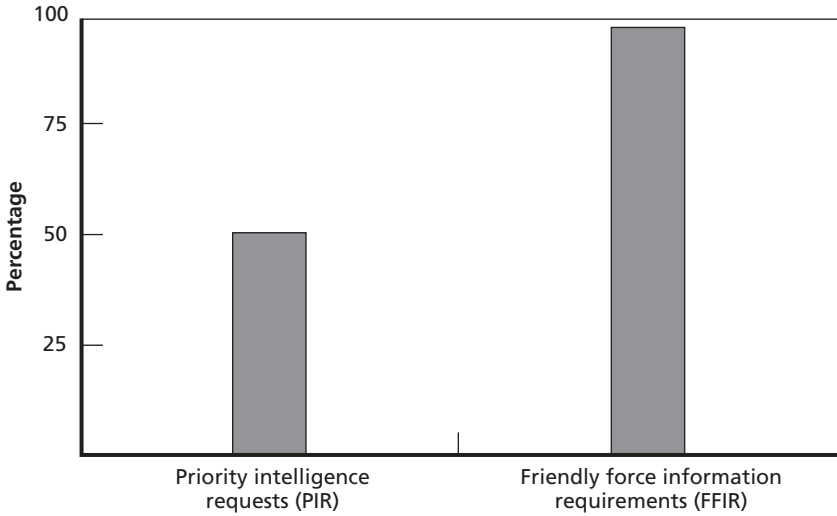

RAND MG267-C.3

- How would you describe your overall level of situational awareness during the Shughart-Gordon planning and execution phases? Was ABCS the primary factor in achieving that level of situational awareness?
- How long did it take you to transition from situational awareness to situational understanding during the Shughart-Gordon attack? Was that significantly better than your experience in nondigital units?

**Quality of Interactions (Collaboration)**

- How did the brigade and your battalion modify MDMP and use ABCS to conduct “multiechelon collaborative planning” before the Shughart-Gordon attack? Was there more collaboration than in your experience in nondigital units?
- Quality: If ABCS provided a better mode for informing unit locations, status, enemy spot reports, etc., was the command net used more effectively for quality collaboration during the

Shughart-Gordon attack? Was this cross talk better than in your experience in nondigital units?

- Reach: Did ABCS allow you to contact the key staff officer or unit commander with the right information when you needed to?
- Latency: Were you able to make the sensor-shooter system work in time to have effects on the enemy during the Shughart-Gordon attack?

### **Quality of Shared Information, Awareness, and Understanding**

- Going back to the figures for measuring the quality of individual information, how would you compare the degree of information shared by your company commanders and brigade TOC to your own during the Shughart-Gordon attack? Consider:
  - Completeness
  - Timeliness
  - Accuracy.
- Was the degree of shared awareness and understanding significantly better than in your experience in nondigital units?
- Was ABCS the primary factor in achieving that degree of shared awareness and understanding? If so, why?

### **Decision Options/Speed of Command**

- Were you able to make better decisions faster than the enemy during the Shughart-Gordon attack? If so, what was the primary factor in achieving this effect?
- Were you able to make better decisions faster than you could in nondigital units?
- The brigade planned to select the avenue of approach during the Shughart-Gordon attack at 1200 hours May 24, 2003, which was 16 hours before the attack time of 0400 hours, May 25, 2003. . . . Do you remember when the brigade commander made his course of action selection and when you attacked?

- Would you please confirm the operational time lines that compare your operations at Shughart-Gordon with a nondigital unit?
- Could a nondigital unit have successfully accomplished the mission using the same method of command (e.g., mission orders, recon-pull operations, decision-point tactics)?

### **Force Agility**

- Reviewing the screen shots saved in the operational effectiveness database, it looks as if the brigade attacked 25 kilometers in less than 20 hours to seize the Shughart-Gordon objective. . . . Could you please describe the actual conduct of the attack?
- The Stryker vehicle obviously offers the SBCT greater mobility than a light infantry unit, but in what other ways did you demonstrate agility during the Shughart-Gordon attack?

### **Force Synchronization**

- What are some examples of successful force synchronization during the Shughart-Gordon attack?
- How did you use ABCS to synchronize operations during the Shughart-Gordon attack?
- Did you achieve more complementary and reinforcing effects than in nondigital units?
- Given the degree of shared situational understanding, could the brigade units “self-synchronize” in accordance with the commander’s intent? Or did commanders still have to direct synchronization during execution to make it happen?

### **Force Effectiveness**

- Do you remember from the after-action report what the friendly-to-enemy casualty ratios were during your Shughart-Gordon attack?



- How does that compare to your experience in nondigital units? Ken Smith at the MSTF suggested the ratios were roughly 16:1 (nondigital) to 1:1 (SBCT). . . . Is that accurate?
- Could you rank order the primary factors that caused this increased force effectiveness (e.g., Stryker mobility, more infantrymen in the box, ABCS, FBCB2 situational awareness)

### **Conclusion**

- Is there anything we have not asked that you think is critical to understand?
- What do you think of network-centric operations?

## **Third Set of Questions**

### **Stryker Brigade Mission Capabilities Package**

- We would like to understand the real value added of the new organizations in the SBCT. . . . Did the cavalry squadron (RSTA battalion) and S-2/military intelligence company analysis allow the brigade to see first, understand the enemy, and select the optimum axis of advance to maneuver decisively during the Shughart-Gordon attack? Or did they make contact and develop the situation as usual?
- We are also trying to measure the utility of the ABCS information network. . . . To what extent did ABCS network enable commanders, staff and units to access and share more information? Was this important during the Shughart-Gordon attack? How does that compare to your previous experience in nondigital units?
- How did the brigade information management system work to promote sharing of critical information and prevent information overload?
- What other operational concepts did the brigade demonstrate during the JRTC CERTEX that you could not do in previous

nondigital units (e.g., mission orders, decision-point tactics, recon-pull operations, and maneuver-warfare)?

**Quality of Individual Information**

- We would like to measure the quality of information that the brigade received from ABCS during the Shughart-Gordon attack according to NCW metrics . . .

Completeness: To what extent did the brigade receive information relevant to ground truth in the following ABCS components? How does that compare to your experience in nondigital units? Use the figure to plot data points by battlefield operating system. Example (see Figure C.4):

**Figure C.4**  
**ABCS Information Completeness**

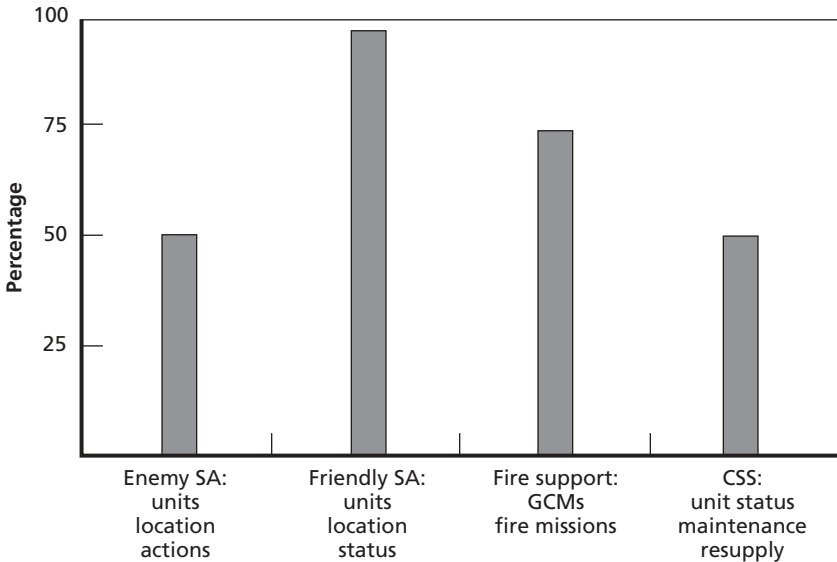

- **Timeliness:** To what extent was the information available to the brigade current in the following ABCS components? How does that compare to your experience in nondigital units? Example (see Figure C.5):

**Figure C.5**  
**ABCS Information Timeliness**

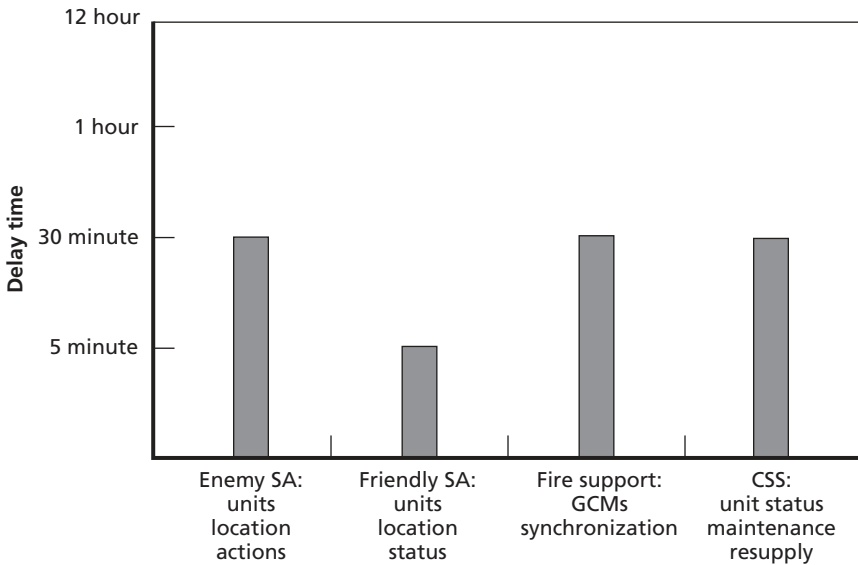

RAND MG267-C.5

- **Accuracy:** To what extent did the brigade receive accurate information necessary to answer CCIR? How does that compare to your experience in nondigital units?

**Figure C.6**  
**ABCS Information Accuracy and Relevance**

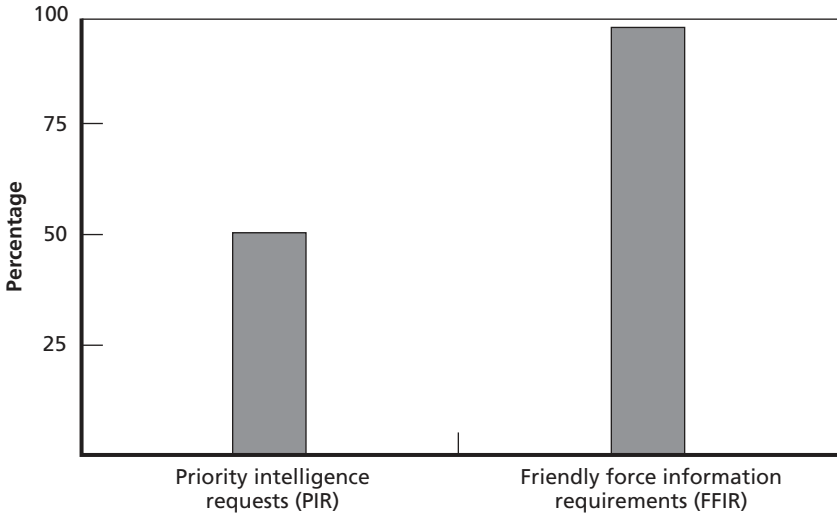

RAND MG267-C.6

- How would you describe their overall level of situational awareness during the Shughart-Gordon planning and execution phases? Was ABCS the primary factor in achieving that level of situational awareness?
- How long did it take unit commanders and primary staff officers to transition from situational awareness to situational understanding during the Shughart-Gordon attack? Was that significantly better than your experience in nondigital units?

### **Quality of Interactions (Collaboration)**

- How did the brigade and the battalions modify MDMP and use ABCS to conduct “multiechelon collaborative planning” before the Shughart-Gordon attack? Was there more collaboration than in your experience in nondigital units?
- Quality: If ABCS provided a better mode for informing unit locations, status, enemy spot reports, etc., was the command net

used more effectively for high-quality collaboration during the Shughart-Gordon attack? Was this cross talk better than in your experience in nondigital units?

- Reach: Did ABCS allow unit commanders to contact the key staff officer or subordinate unit with the right information when they needed?
- Latency: Were they able to make the sensor-shooter system work in time to have effects on the enemy during the Shughart-Gordon attack?

### **Quality of Shared Information, Awareness and Understanding**

- Going back to the figures for measuring the quality of individual information, how would you compare the degree of information shared by the brigade and battalions during the Shughart-Gordon attack? Consider:
  - Completeness
  - Timeliness
  - Accuracy
- Was the degree of shared awareness and understanding across the brigade significantly better than in your experience in non-digital units?
- Was ABCS the primary factor in achieving that degree of shared awareness and understanding? If so, why?

### **Decision Options/Speed of Command**

- Were the commanders able to make better decisions faster than the enemy during the Shughart-Gordon attack? If so, what was the primary factor in achieving this effect?
- Were they able to make better decisions faster than in nondigital units?
- The brigade planned to select the avenue of approach during the Shughart-Gordon attack at 1200 hours, May 24, 2003, which was 16 hours before the attack time of 0400 hours May 25,

2003. . . . Do you remember when the brigade commander made his course of action selection and when 1-23 IN attacked?

- Would you please confirm the operational timelines that compare your operations at Shughart-Gordon with a nondigital unit?
- Could a nondigital unit have successfully accomplished the mission using the same method of command (e.g., mission orders, recon-pull operations, decision-point tactics)?

### **Force Agility**

- Reviewing the screen shots saved in the operational effectiveness database, it looks as if the brigade attacked 25 kilometers in less than 20 hours to seize the Shughart-Gordon objective. . . . Could you please describe the actual conduct of the attack?
- The Stryker vehicle obviously offers the SBCT greater mobility than a light infantry unit, but in what other ways did the SBCT demonstrate agility during the Shughart-Gordon attack?

### **Force Synchronization**

- What are some examples of successful force synchronization during the Shughart-Gordon attack?
- How did the brigade use ABCS to synchronize operations during the Shughart-Gordon attack?
- Did the brigade achieve more complementary and reinforcing effects than in nondigital units?
- Given the degree of shared situational understanding, could the brigade units “self-synchronize” in accordance with the commander’s intent? Or did commanders still have to direct synchronization during execution to make it happen?

### **Force Effectiveness**

- Do you remember from the after-action report what the friendly to enemy casualty ratios were during the Shughart-Gordon attack?

- How does that compare to your experience in nondigital units? Ken Smith at the MSTF suggested the ratios were roughly 16:1 (nondigital) to 1:1 (SBCT). . . . Is that accurate?
- Could you rank order the primary factors that caused this increased force effectiveness? (e.g., Stryker mobility, more infantrymen in the box, ABCS, FBCB2 situational awareness)

**Conclusion**

- Is there anything we have not asked that you think is critical to understand?
- What do you think of network-centric operations?





## Bibliography

---

- Alberts, David S., *Mission Capability Packages*, Strategic Forum, Institute for National Strategic Studies, No. 14, January 1995, available at <http://www.ndu.edu/inss/strforum/z1405.html>.
- Alberts, David S., and John J. Garstka, *Network Centric Warfare Department of Defense Report to Congress*, July 27, 2001.
- Alberts, David S., and Richard E. Hayes, *Power to the Edge: Command, Control in the Information Age*, Department of Defense Command and Control Research Program (CCRP), June 2003.
- Alberts, David S., John J. Garstka, and Frederick P. Stein, *Network Centric Warfare: Developing and Leveraging Information Superiority*, Second Edition (Revised), Washington, D.C.: CCRP Publication Series, 1999.
- Alberts, David S., John J. Garstka, Richard E. Hayes, and David A. Signori, *Understanding Information Age Warfare*, Washington, D.C.: CCRP Publication Series, August 2001.
- Brown, Colonel Robert B., U.S. Army, and Command Sergeant Major Carlton E. Dedrich, U.S. Army, *Developing Agile, Adaptive Soldiers, Military Review*, May-June 2003, pp. 33–41.
- Cebrowski, Vice Admiral Arthur K., USN, and John J. Garstka, “Network Centric Warfare: Its Origin and Future,” *U.S. Naval Institute Proceedings*, January 1998.
- Charlton, Lieutenant Colonel John W., U.S. Army, “Digital Battle Command Baptism by Fire,” *Armor*, November–December 2003, Vol. 112, No. 6, pp. 26–29, 50.

- Cody, Lieutenant General Richard A., Department of the Army, Deputy Chief of Staff, G-3, *Office of Force Transformation (OFT)/RAND Study of Network Centric Warfare Conceptual Framework and the Stryker Brigade Combat Team (SBCT)*, October 7, 2003.
- Command and Control Research Program, *NATO Code of Best Practice for C2 Assessment: Decisionmaker's Guide*, revised 2002, available at <http://www.dodccrp.org>.
- Director, Office of Force Transformation, *Office of Force Transformation (OFT)/RAND Study of Network Centric Warfare Conceptual Framework and the Stryker Brigade Combat Team (SBCT)*, October 7, 2003.
- Evidence Based Research, Inc., "Network Centric Operations Conceptual Framework, Version 1.0," prepared for John Garstka, Office of Force Transformation, November, 2003, available at <http://www.oft.osd.mil>.
- Gritton, Eugene C., Paul K. Davis, Randall Steeb, and John Matsumura, *Ground Forces for a Rapidly Employable Joint Task Force: First-Week Capabilities for Short-Warning Conflicts*, Santa Monica, Calif.: RAND Corporation, MR-1152-OSD/A, 2000.
- I Corps, *Stryker Brigade Operational Evaluation Database, and References Therein*, unredacted, received by RAND January 2004. Government publication; not releasable to the general public.
- Light Infantry Brigade Joint Readiness Training Center Rotation, "*Take Home*" Package (Anonymous Unit), provided to RAND fall 2003. Government publication; not releasable to the general public.
- Matsumura, John, Randall Steeb, John Gordon, Russell W. Glenn, Thomas J. Herbert, and Paul Steinberg, *Lightning over Water: Sharpening America's Light Forces for Rapid-Reaction Missions*, Santa Monica, Calif.: RAND Corporation, MR-1196-A/OSD, 2001.
- PA Consulting Group, *Network Centric Case Study: US/UK Coalition Operations During Operation Iraqi Freedom*, 2004.
- Perry, Walt L., David Signori, and John Boon, "Exploring Information Superiority: A Methodology for Measuring the Quality of Information and Its Impact on Shared Awareness," Santa Monica, Calif.: RAND Corporation, MR-1467-OSD, 2004.

- Signori, David A., et al., "A Conceptual Framework for Network Centric Warfare," presented at The Technical Cooperation Program's Network Centric Warfare/Network Enabled Capabilities Workshop, Virginia, December 17, 2002, available at <http://www.dodccrp.org>.
- Signori, David, John Hollywood, Gina Kingston, and Daniel R. Gonzales, *A Conceptual Framework for Network Centric Warfare*, Santa Monica, Calif.: RAND Corporation, DB-431-OSD, 2004.
- Stryker Brigade Combat Team, Joint Readiness Training Center Certification Exercise (CERTEx) Database, provided to RAND fall 2003. Government publication; not releasable to the general public.
- Take Charge: Leaders Agility Book*, Version 4, SBCT, March 2003.
- TRADOC, *Interim [Stryker] Brigade Organizational and Operational Concept*, June 30, 2000.
- U.S. Army, Headquarters, Field Manuals 7-8 (HTF), *The Infantry Rifle Platoon and Squad*, April 1992.
- \_\_\_\_\_, Field Manuals 7-30, *The Infantry Brigade*, October 1995.
- \_\_\_\_\_, Field Manuals 7-20 (HTF), *The Infantry Battalion*, April 1992.
- U.S. Army, Forces Command I Corps Operational Evaluation Control Cell, *Final Report on the Operational Evaluation of First Stryker Brigade Combat Team*, Fort Lewis, Wash., August 13, 2002. Government publication; not releasable to the general public.