

# UPCommons

## Portal del coneixement obert de la UPC

<http://upcommons.upc.edu/e-prints>

---

Luo, L.; Han, B.; Rosas, M. (2016) Network hierarchy evolution and system vulnerability in power grids. *IEEE systems journal*. Doi: <http://dx.doi.org/10.1109/JSYST.2016.2628410>.

© 2016 IEEE. Es permet l'ús personal d'aquest material. S'ha de demanar permís a l'IEEE per a qualsevol altre ús, incloent la reimpressió/reedició amb fins publicitaris o promocionals, la creació de noves obres col·lectives per a la revenda o redistribució en servidors o llistes o la reutilització de parts d'aquest treball amb drets d'autor en altres treballs.

Luo, L.; Han, B.; Rosas, M. (2016) Network hierarchy evolution and system vulnerability in power grids. *IEEE systems journal*. Doi: <http://dx.doi.org/10.1109/JSYST.2016.2628410>.

(c) 2016 IEEE. Personal use of this material is permitted. Permission from IEEE must be obtained for all other users, including reprinting/republishing this material for advertising or promotional purposes, creating new collective works for resale or redistribution to servers or lists, or reuse of any copyrighted components of this work in other works.

# Network Hierarchy Evolution and System Vulnerability in Power Grids

Lingen Luo, Bei Han, and Marti Rosas-Casals

**Abstract**—The seldom addressed network hierarchy property and its relationship with vulnerability analysis for power transmission grids from complex systems point of view is given in this paper. We analyze and compare the evolution of network hierarchy for the dynamic vulnerability evaluation of four different power transmission grids of real cases. Several meaningful results suggest that the vulnerability of power grids can be assessed by means of a network hierarchy evolution analysis. Firstly, the network hierarchy evolution may be used as a novel measurement to quantify the robustness of power grids. Secondly, an anti-pyramidal structure appears in the most robust network when quantifying cascading failures by the proposed hierarchy metric. Furthermore, the analysis results are also validated and proved by empirical reliability data. We show that our proposed hierarchy evolution analysis methodology could be used to assess the vulnerability of power grids or even other networks from a complex systems point of view.

**Index Terms**—Complex networks, hierarchy, power grids, vulnerability, cascading failures.

## I. INTRODUCTION

**H**IERARCHY property is an important characteristic of complex networks [1]-[5]. Complex systems are usually characterized by some level of hierarchy, which spans in time and space at different scales. This hierarchical structure commonly allows reducing costs in terms of reliably transmitted information but at the same time involves different dynamical responses to malfunctions. Power grids, especially power transmission networks, have been widely studied under the complex network science framework, and basic topological characteristics and statistical global graph properties have been analyzed for many power grids around the world [6]. Thus, power systems considered as typical complex networks, would also be featured with the hierarchy property. However, to our best knowledge, existing researches about complex network theory in power grids mainly focus on very common measures taken from graph theory, like degree, efficiency, betweenness, etc., and for structural vulnerability analysis [6]-[8]. Research concerning the relation between hierarchy and vulnerability has been seldom addressed except for [9] where only simple graph

models and hierarchy metrics are taken into consideration. In this paper, we extend the static metric to the evolution of network hierarchy for dynamic evaluation of power system vulnerability, which has been seldom addressed among the complex system approaches but would greatly change the judgments on power system vulnerability.

To be more specific, among different network evolution properties indicating the dynamic behavior in terms of system vulnerability, an especially important one to be addressed and adopted in this paper is the hierarchy metric, quantifying the network pyramidal structure [10]-[12]. Here, and in order to quantify this pyramidal property in the case of a power network, we adopt and simplify “*treeness*” [13] as our metric to analyze hierarchy evolution property of power networks, and to achieve balance between accuracy and computation burden. It’s noticed that the hierarchy conception is based on a directed network which is also a natural feature for power network due to its power flow. Therefore, the DC power flow model is used and calculated to obtain branch flows and to generate the corresponding directed graph.

Based on the proposed hierarchy metric and the directed graph model, we applied this approach to analyze the evolution of hierarchy in power grids from a dynamic process performed with node removal. The strategy of randomly removing buses, one by one, was adopted, and the corresponding hierarchy metric is calculated and recorded. We found that hierarchy trends illustrated by our proposed metric can be translated as a footprint of power system vulnerability (caused by node removal) from complex network point of view.

The methodology has been applied in the following steps. Firstly, the topological characteristics of four power networks are carefully checked to make sure they are compatible from complex network theory point of view. Secondly, to more precisely investigate the dynamic behavior of the power grids, the network hierarchy evolution observation is incorporated into the cascading failures model. By the simulation, a correlation between network hierarchy evolution and cascading failures propagation was analyzed and built. An initial correlation between network hierarchy evolution and system vulnerability was given. Finally, we also try to use the empirical data supplied by ENTSO to validate our previous findings.

The remainder of this paper is organized as follows. Section II introduces the proposed mathematical and simulation methods. Section III describes the case studies used in this paper and their corresponding analyses are also addressed. The

Lingen Luo and Bei Han are with the Department of Electrical Engineering, Shanghai Jiao Tong University, Shanghai, China (e-mail: llg523@sjtu.edu.cn; han\_bei@sjtu.edu.cn).

Marti Rosas-Casals is with the Sustainability Measurement and Modelling Lab, Universitat Politècnica de Catalunya – Barcelona Tech, 1, Colom St., 08222, Terrassa, Spain (e-mail: marti.rosas@upc.edu).

reliability validation with empirical data is presented in section IV for further discussion of previous results from a more practical point of view. Section V highlights the key findings of this paper and draws conclusions.

## II. MATHEMATICAL APPROACH AND METHODOLOGY

### A. Traditional topology metrics

The power network could be abstracted as an undirected graph model  $G_u = (n, m)$ , consisting of two sets  $n$  and  $m$ , such that  $n \neq \emptyset$  and  $m$  is a set of unordered pairs of elements of  $n$ . The elements of  $n \equiv \{n_1, n_2, \dots, n_N\}$  are the nodes (or vertices) of the graph  $G_u$ , while the elements of  $m \equiv \{m_1, m_2, \dots, m_M\}$  are the links (or edges) [14].

The connectivity of a node is measured by its degree,  $k_i$ , which is defined as the number of edges connected to a given node  $i$  [15]. The average degree  $\langle k \rangle$  describes the average connectivity of all vertices in a graph [16]:

$$\langle k \rangle = \frac{1}{M} \sum_{i \in m} k_i \quad (1)$$

Shortest path length  $d_{ij}$  is the number of edges in the shortest path between node  $i$  to node  $j$ . Typical separation between two nodes in the graph is given by the average path length  $L$ , defined as the mean of  $d_{ij}$  over all couples of nodes [17]:

$$L = \frac{1}{N(N-1)} \sum_{i, j \in n, i \neq j} d_{ij} \quad (2)$$

In a network, clustering coefficient is introduced to quantify the average connectivity of neighbors of nodes in a network. The overall level of clustering is measured by the average of the local clustering coefficients  $C_i$  over all nodes [17]:

$$C = \frac{1}{n} \sum_{i \in n} C_i \quad (3)$$

### B. Hierarchy measure for power grids

Hierarchy can be seen as some kind of relations about the interactions between the system elements. Therefore, in this paper we would like to address the hierarchy evolution of power grids by means of a directed graph  $G = (V, E)$ , consisting of two sets  $V$  and  $E$ , such that  $V \neq \emptyset$  and  $E$  is the pairs of elements in  $V$ . The elements of  $V$  are the vertices (or nodes) of the graph  $G$  corresponding to the buses. And each edge  $\{v_i, v_j\} \in E$  is characterized by its reactance  $x_{ij} = x_{ji} > 0$  denoting the transmission lines [18]. As a directed graph,  $\{v_i, v_j\} \in E$  also denotes an arrow going from  $v_i$  to  $v_j$ . Furthermore, to obtain the directed graph model of a power network, power flow calculations need to be carried out for the flow direction of each edge. For the sake of simplicity, a linearized (or DC) power flow model is adopted [19]. Given the power supply/demand vector  $P \in \mathbb{R}^{|V| \times 1}$  where  $p_v$  is the active power supply ( $p_v > 0$ ) or

demand ( $p_v < 0$ ) at node  $v \in V$ , the DC power flow equation is given in matrix form as follows:

$$P = B\theta \quad (4)$$

where  $\theta \in \mathbb{R}^{|V| \times 1}$  is the vector of phase angles and  $B \in \mathbb{R}^{|V| \times |V|}$  is the admittance matrix of the graph  $G$  defined as:

$$b_{ij} = \begin{cases} 0, & \text{if } i \neq j \text{ and } \{v_i, v_j\} \notin E \\ -1/x_{ij}, & \text{if } i \neq j \text{ and } \{v_i, v_j\} \in E \\ -\sum_{\substack{k=1,2,\dots,N \\ k \neq i}} b_{ik}, & \text{if } i = j \end{cases}$$

After solving  $\theta$  by (4), the branch flow  $P_E \in \mathbb{R}^{|E| \times 1}$  could be calculated by:

$$P_E = DA\theta \quad (5)$$

where  $D \in \mathbb{R}^{|E| \times |E|}$  is defined as:

$$d_{ij} = \begin{cases} 0, & \text{if } i \neq j \\ -1/x_{ij}, & \text{if } i = j \end{cases}$$

and  $A \in \mathbb{R}^{|E| \times |V|}$  is known as the incidence matrix [20] whose element  $a_{ij}$  is 1 if the  $i^{\text{th}}$  branch begins at node  $j$ , -1 if the  $i^{\text{th}}$  branch terminates at node  $j$ , and 0 otherwise. Here, a branch is said to “begin” at node  $j$  if the power flowing across branch  $i$  is defined positive for a direction from node  $j$  to the other node, on the contrary defined as “terminate”.

As an example, the DC power flow of WSCC 9-bus system is solved by MATPOWER 4.0 and the power flow direction of each branch is denoted in Fig. 1 (a). The corresponding directed graph is abstracted and shown in Fig. 1 (b).

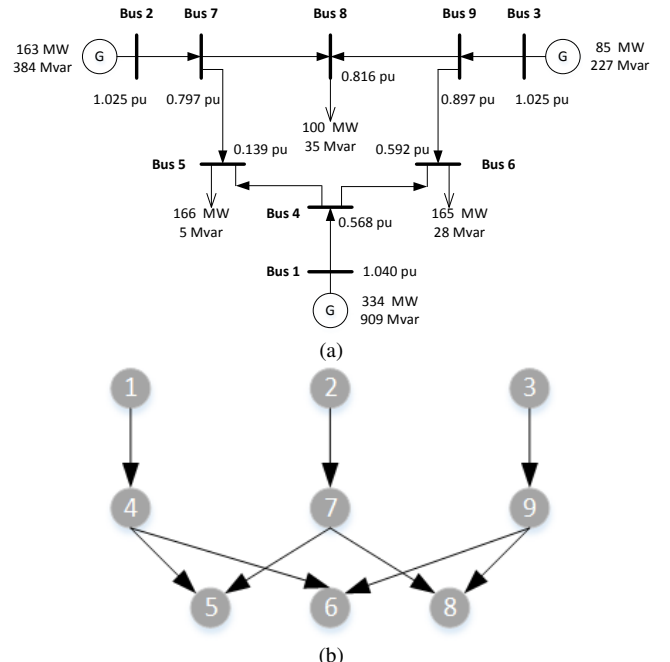

Fig. 1. Directed graph abstracted from power network. (a) DC power flow result of WSCC 9-bus system by MATPOWER 4.0; (b) the corresponding directed graph.

In this paper, and based on directed graph model for power networks, a hierarchy measure to quantify the pyramidal structure of a power grid is simplified and drawn from [13]. We would like to use a simplified version of “*treeness*” as the hierarchy metric of power grids which accounts for the pyramidal structure:

$$T(G) = \frac{H_f(G) - H_b(G)}{\max\{H_f(G), H_b(G)\}} \quad (6)$$

where  $H_f(G)$  and  $H_b(G)$  measure the diversity of choices we can make going top–down (following the arrows of the structure) vs. the uncertainty generated when reverting the paths going bottom–up:

$$H_f(G_C) = \frac{1}{|M|} \sum_{v_i \in M} h(v_i) \quad (7)$$

where  $G_C$  is the DAG (directed acyclic graph) of  $G$  which is a directed graph characterized by the absence of cycles, and the set  $M$  denotes the nodes whose in-degree equals zero:

$$M = \{v_i \in V : k_{in}(v_i) = 0\}$$

Here,  $k_{in}$  is the in-degree of  $v_i$  that indicates the number of ingoing (the flow injected in the node) links of  $v_i$ , and  $h(v_i)$  measures the uncertainty associated to a given path starting from  $v_i$  and ending to some node in  $\mu$ :

$$h(v_i) = \sum_{\pi_k \in \Pi_{M\mu}} \mathbb{P}(\pi_k | v_i) \log \mathbb{P}(\pi_k | v_i) \quad (8)$$

where  $\mathbb{P}(\pi_k | v_i)$  is the probability that the path  $\pi_k$  is followed, starting from node  $v_i \in M$ . Here, set  $\mu$  denotes the nodes whose out-degree equal to zero:

$$\mu = \{v_i \in V : k_{out}(v_i) = 0\}$$

where  $k_{out}$  is the out-degree of  $v_i$  that indicates the number of outgoing links of  $v_i$ , and the set of all paths  $\pi_1, \dots, \pi_s$ , from  $M$  to  $\mu$  is indicated as  $\Pi_{M\mu}(G)$ .

To obtain  $H_b(G)$ , the analogue expression of (8) can be applied just reversing the flow defined by the arrows in  $G$ .

The general procedure to calculate the *treeness* of a power network is: firstly, build the corresponding directed graph by DC power flow calculation; secondly generate the corresponding DAG model; finally, calculate  $T(G)$  following (6).

### C. Observations of hierarchy trends

The main motivation for the studies of power grids in network theory is the assessment of resilience (or vulnerability) [21]-[23]. Specifically, in order to provide a sustained functioning capacity, power networks must be designed to withstand a considerable amount of random removal of some important elements. Such directed impairment to this kind of network has dramatic structural effects, typically leading to

network fragmentation [24]. Based on this consideration, we assume that a power grid failure will also be revealed as a variation in the hierarchy coordinates. In this sense, we analyse the relationship between random bus and generator removal and the evolution of the network hierarchy.

A Monte Carlo based simulation is proposed and carried out repeatedly in the following steps:

Step 1: a random node is uniformly selected and removed from the power network (and for the next simulation cycle, the same action would be done for a second random node);

Step 2: the largest connected island containing at least one generator would be found in the remaining network and DC power flow of the survival largest island would be carried out to generate its according directed graph model;

Step 3: calculate the hierarchy metric (*treeness*) for the largest connected island to observe the hierarchy trends;

Step 4: go to step 1 to randomly select and remove another node, and repeat these same steps until only one generator node exist in the resulting largest island.

The previous simulation algorithm is repeated a selected number of times with a different sequence of nodes to be removed for each network case study. Here four transmission power networks case studies have been selected: Germany (DE), France (FR), Spain (ES) and Italy (IT).

### D. Vulnerability and network hierarchy evolution

Several models have been proposed for explaining the complex behavior of cascading failures in power networks [25]-[28]. Generally speaking, there are two kinds of technical approaches. One is the traditional N-1 contingency simulation. The other is a simplified version where only the network topology is taken into account. To achieve a balance between the computation complexity (in terms of number of buses and lines, especially for DE and FR networks) and simulation accuracy, we propose a modified version which overcomes the shortcoming of simplified cascading failures model. In Motter's work [27], the network flow is quantified by the shortest path length which counts the edges connecting each pair of nodes. In Crucitti's work [28], a weighted network is used, the shortest path is the path with minimal sum of weights of edges between two nodes. However, power network is a flow based network where power is transmitted from power plants to consumers not only along the shortest path but also the remaining paths, following not purely by topological rules. To describe the flow redistribution mechanism in cascading failure propagation, a DC power flow could be taken into consideration. Some researches [29] have addressed the line outage cascading model for power networks based on the DC power flow equation.

$$Cap_i = (1 + \alpha)L_i(0) \quad (9)$$

where  $\alpha \geq 0$  plays the role of a tolerance parameter, and  $L_i(0)$  is the load of each node for the intact network.

The node outage cascading failure is carried out as following: randomly select a node and remove it from the network as it fails; then the power flow undergoes a redistribution, and consequently, the loads on each surviving

node change. If the node has a large load, its removal will probably affect the loads of the rest of the nodes. If the new load after flow redistribution of any surviving node exceeds its capacity (i.e.,  $L_i \geq Cap_i$ ), then that node will also fail, which leads to a further redistribution and possible further failures until a certain point in time, when all loads in the remaining nodes are lower than or equal to their capacity.

The cascading failures propagation may lead to the network fragmentation and the loss of power consumption. For power systems, the surviving power consumption is suitable to evaluate the consequence of cascading failures:

$$P_{ratio} = P^{new} / P^{initial} \quad (10)$$

where  $P^{new}$  is the existing power generation belonging to the largest network component after the cascade, and  $P^{initial}$  is the original total power generation.

The cascading failures model considered in our examination and the hierarchy evolution are performed as following:

**Step 1:** Calculate the capacity for each bus according to (9) and set the initial value of control parameter  $\alpha$  as 0.1.

**Step 2:** Randomly (following uniform distribution) remove a node from the network.

**Step 3:** Find the largest island among the fractions caused by the node removal. Notice that only the island with at least one generator has source for energy dispatching.

**Step 4:** Calculate the hierarchy metric value for the island found in step 3.

**Step 5:** Redistribute the power flow by (7) and (8) in the island found in step 3 and update the load on each bus following redistribution results.

**Step 6:** Compare the newly distributed load with the capacity of each bus and remove the buses whose load exceed their capacity to trigger the next failure.

**Step 7:** Calculate the surviving power consumption of the largest connected component according to (10).

**Step 8:** Go to Step 3 and find the largest island with a generator, until no generator can be found in each island.

**Step 9:** Increase the control parameter  $\alpha$  by 0.1 interval, and redo from step 2 to step 8 until  $\alpha$  equal 1.0.

The simulation would also be repeated for a specific number of times in order to achieve a meaningful result.

### III. CASE STUDIES

To conduct in-depth analysis for the hierarchy and vulnerability properties of power grids in terms of real case except for toy model, four major power transmission networks from the European Network of Transmission System Operators (ENTSO/UCTE) have been chosen: France (FR), Germany (DE), Italy (IT) and Spain (ES). Some basic information of these four power grids are reported in Table I and their corresponding graphical illustrations have been plotted by NodeXL [30]. For each power grid, graphs are shown in the Appendix (Fig. 5 to Fig. 8).

TABLE I  
POWER GRID DATA SETS

Geography	Buses	Branches	Generators	Loads
France	1401	1819	136	881
Germany	1197	1714	156	602
Italy	535	645	126	249
Spain	447	644	100	349

#### A. Traditional topological property analysis

Firstly, the topological properties of the four power networks are investigated by means of commonly used metrics in complex network analysis. We assess and compare the structural features of FR, DE, IT and ES power grids using topological metrics respectively as shown in Table II.

TABLE II  
STRUCTURAL CHARACTERISTICS OF POWER GRIDS IN TOPOLOGICAL METRICS

Power grid	$\langle k \rangle$	$L$	$C$
France	2.597	11.283	0.062
Germany	2.779	15.420	0.075
Italy	<b>2.461</b>	11.761	<b>0.033</b>
Spain	2.888	8.914	0.104

According to the metrics listed in Table II, these four power grids are quantitatively similar and compatible from a complex networks point of view. However, it's worth noting that Italy power network has the smallest average degree  $k$  and overall clustering  $C$ , which means that Italy network is sparser and more weakly connected than the rest of the power networks.

#### B. Hierarchy metric and its trend observation

Following the *treeness* calculation procedure, the *treeness* of our four major power transmission networks is calculated and reported in TABLE III.

TABLE III  
TREENESS OF EACH ORIGINAL POWER NETWORK

Geography	France	Germany	Italy	Spain
<i>Treeness</i>	-0.0334	0.0073	<b>-0.1159</b>	0.0997

We observe that the *treeness* value of Italy is the smallest one in the four power grids (shown in TABLE III, bold value). Compared with the topological metrics in Table II, Italy exhibits a consistent feature of minimal values, both for pure topological and hierarchy metrics.

Furthermore, we also examine the trend in hierarchy coordinates when power transmission networks are damaged by random node removal

In our study, and in order to make the Monte Carlo based simulation (see section II.C) more meaningful, the simulation is performed 1000 times, considering the balance of computational burden. Fig. 2 shows the results from this simulation, with *treeness* values against the number of nodes removed and for each power grid. An immediate conclusion can be drawn from this first simulation result, which is that the network hierarchy trends caused by random node removal strategy exhibits different patterns for different power grids.

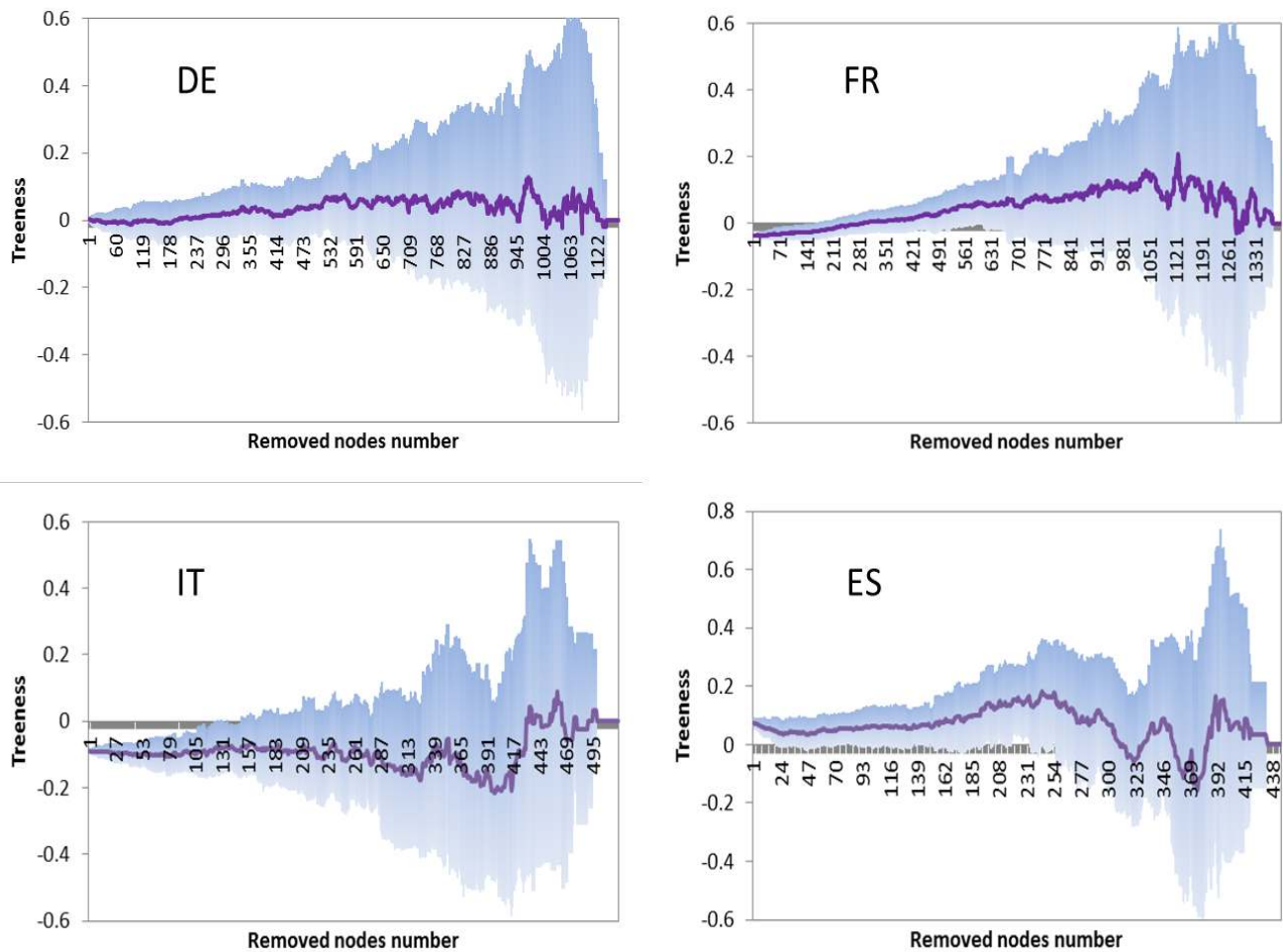

Fig. 2. Hierarchy trends caused by random node removal for each power grid. Mean in purple, standard deviation in shadow.

To be more specific, in Fig.2 we make observations and corresponding hints of the four power grids from both topological and dynamic points of view. (The left part of the curves with less nodes removed are more valuable to observe, since they would be more realistic for power grids.). From Fig. 2, the following observations can be summarized:

1) *Treeness* values fluctuate in a very small area especially in the left part of the curves for each network. This feature is a consequence of engineering practices focused on reducing the wiring costs while keeping the system connected [11]. In other words, the power grids behave in a more planar fashion and generally as a less meshed graph.

2) Italy and Spain networks have a definite stable hierarchy structure during the node removal procedure. The difference is that Italy network has a reverse pyramidal shape, while for Spain network is a pyramidal one. Namely, the sign of the hierarchy may point out some main dynamic feature of the network and be a critical index classifying transmission networks with respect to vulnerability.

3) The *treeness* of the Germany network stands between that of Italy and Spain, and the absolute value of this metric is very close to 0, especially in the left part of the curves. From a topological view, it suggests that Germany network hierarchy

evolution during the node removal maintains a more meshed structure compared to the other networks.

4) There is a dynamic change of the *treeness* sign (from negative to positive) for France network, and the *treeness* is mainly linear with respect to the shrinking of the network island. Keeping in mind a common power engineering knowledge that fractional networks would always be less robust than the original complete one (less supporting power supplying lines as backups for failures), the evolution of vulnerability can be witnessed through the evolution of hierarchy in France network: becoming more vulnerable with more nodes removed and a shrinking network island.

In short, there is an obvious linkage between the hierarchy trends and system dynamic scenario performed in terms of random node removal. Since this kind of dynamic scenario based on node removal is widely used for vulnerability analysis of different systems [6], it provides a possibility to investigate the network vulnerability from hierarchy evolution point of view. Therefore, in next section we propose a cascading failures model based simulation together with the network hierarchy evolution to study the correlation between vulnerability and hierarchy.

C. Vulnerability and network hierarchy evolution

In section III.B, we claimed that network hierarchy trends caused by node removal could be translated as a footprint of power grid vulnerability from complex network point of view. However, a more critical problem is to find out the rationality behind the evolution of network hierarchy, and thus to predict dynamic responses and damages following cascading failures of power grids. Therefore, in this section, a stricter examination concerning cascading failures involving network hierarchy evolution must be carried out still on the real transmission network cases of the four countries.

The simulation proposed in section II.D was performed 100 times for each power transmission grid and the average values of  $P_{ration}$  V.S.  $\alpha$  are shown in Fig. 3. Corresponding network hierarchy evolution (*treeness*) of the four network cases is recorded and reported in Fig. 4.

From Fig. 3, we observe that Italy power network has the most robust structure compared to the other networks, shown by the largest  $P_{ratio}$  value during the whole process of variation of the control parameter. The interesting aspect is that the *treeness* values for the Italy network remain negative for all  $\alpha$  values as shown in Fig.4. Therefore, the first conjecture we can preserve is that the negative *treeness* during cascading failures may hold back the failure propagation, making the network more robust. This conjecture can be verified from the curve of France network in both Fig. 3 and Fig. 4. In this case, there is a leap of  $P_{ratio}$  when the control parameter  $\alpha$  is increased more than 0.3 (shown in Fig. 3), while corresponding *treeness* values are distributed in two groups respectively, with positive and

negative signs in Fig.4.

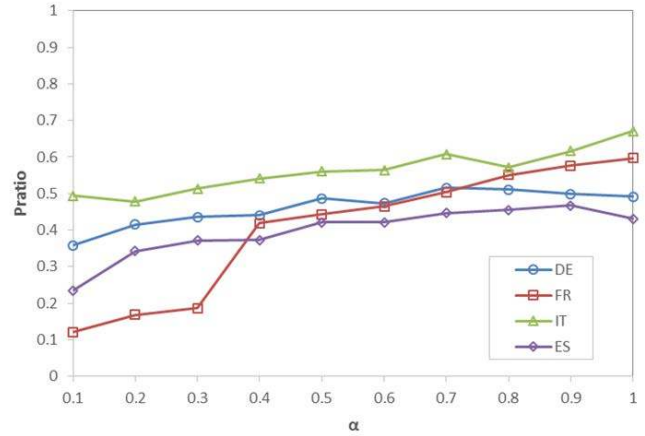

Fig. 3. Cascades triggered by random node removal in four power grids.

Furthermore, from the curves of Germany and Spain networks in Fig. 3 we can observe two more phenomena and make initial judgments from the previous logic. Firstly, their  $P_{ratio}$  is less than that of Italy, which means they are more vulnerable. Secondly Spain network is more robust than Germany. These initial judgments can be again validated by Fig. 4, in which the *treeness* values of Germany and Spain networks are positive, and the Spain network generally has larger *treeness* than Germany. Thus, we could draw a second conjecture, which is that the network hierarchy (*treeness*) evolution under random node removal may be used as a measurement to quantify the robustness of power grids.

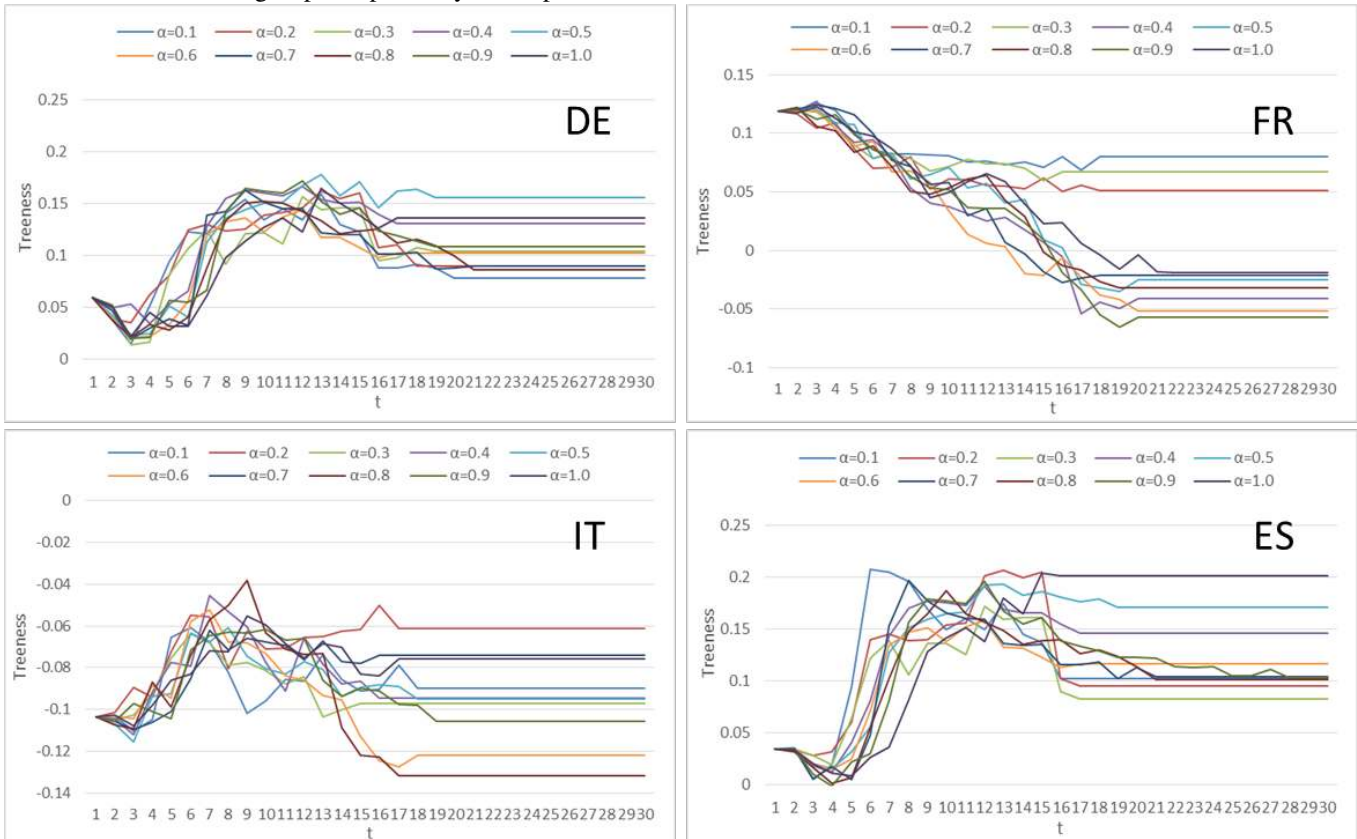

Fig. 4. Network hierarchy evolution during the cascading failures.



In conclusion, a linkage between network hierarchy evolution and vulnerability can be established. This relationship can be used in many ways for power network vulnerability analysis, especially under cascading failures. Firstly, and most straight ahead, a power network cascading failure process can be illustrated by the hierarchy evolution from the complex network theory, and differently from other traditional ways, using shrinking network and capacity. Secondly, the network hierarchy evolution by random node removal strategy can also measure the robustness of a power network, shown by the consistency of results from Fig. 3 and 4. Finally, the value of the network *treeness*, which can also be easily quantified, may, in the same way, influence the network dynamic propagation, characterizing the network vulnerability under cascading failures.

#### IV. VALIDATION FROM REAL FAILURE EVENTS

In the previous two sections, we have used scenario-based statistical simulation method to suggest the linkage between network hierarchy evolution and vulnerability of power transmission grids. However, to make the simulation results more conclusive, we would like to validate our previous conjectures with empirical reliability data before making further conclusions of the paper: with the ENTSO providing a set of real malfunction data of power transmission grids [31] for our validation purpose, statistics of major events from the year 2000 to 2015 are reported in Table IV.

Comparing with the vulnerability ranking of the four countries from previous simulation results, the statistics of major events show supportive conclusions that Italy network has the minimum number of failures while France network has the maximum one, which means from a practical point of view that Italy network is more robust and that the France network is more fragile in these four power grids. This conclusion is surprisingly coincident with the results from our previous simulations. Therefore, our proposed linkage between network hierarchy evolution and vulnerability can be confirmed from both simulation and empirical data.

TABLE IV  
MAJOR EVENTS OF EACH POWER GRID

Network	Germany	France	Italy	Spain
Major events count	83	250	43	175

#### V. CONCLUSIONS

In this paper, a hierarchy metric has been for the first time introduced in the vulnerability assessment of power transmission grids. We have analysed the hierarchy evolution of four major ENTSO power grids: Italy, Germany, Spain and France. We have been able to rank the robustness of these networks and, more importantly, we have shown that hierarchy evolutions are highly correlated with network vulnerability under both static network conditions and network cascading failures. As it is evident from our experimental results in these four major ENTSO power grids, our methodology can be extended to other applications of the hierarchy evolution to the

vulnerability analysis of power grids, or even more generally in any other complex network similarly defined.

Future extensive applications of network hierarchy evolution in power engineering, can be listed, but not limited, in the following aspects. 1) The most direct application of hierarchy metric for power engineering would be the estimation of power network vulnerability and the ranking of their important elements by the observations of hierarchy trends, as it has been done in section 3. 2) A prediction for the severity of cascading failures introduced by the loss of important network elements can be accomplished in terms of hierarchy, a mathematical index, instead of circumstantial simulation with the whole network and particular scenarios. 3) The capability of hierarchy in identifying different significance of network elements and districts in improving system vulnerability can be applied for future power network planning (e.g., enhancement and expanding). 4) Last but not least, for a robust application of the hierarchy evolution, a line of future work of the paper must be centered around the problem of taking into account the uncertainties from network interconnections and large penetration of distributed generation, thus to determine the impact for network vulnerability under these two circumstances.

#### ACKNOWLEDGMENT

We thank Complex Systems Laboratory members, and specially Bernat Corominas-Murtra and Carlos Rodriguez-Caso, for useful discussions and to make the software package to obtain hierarchy coordinates available to the scientific community. This work was supported by the National Natural Science Foundation of China (514070116).

#### APPENDIX

THE SIZE OF THE NODES IN EACH GRAPH IS PROPORTIONAL TO DEGREE

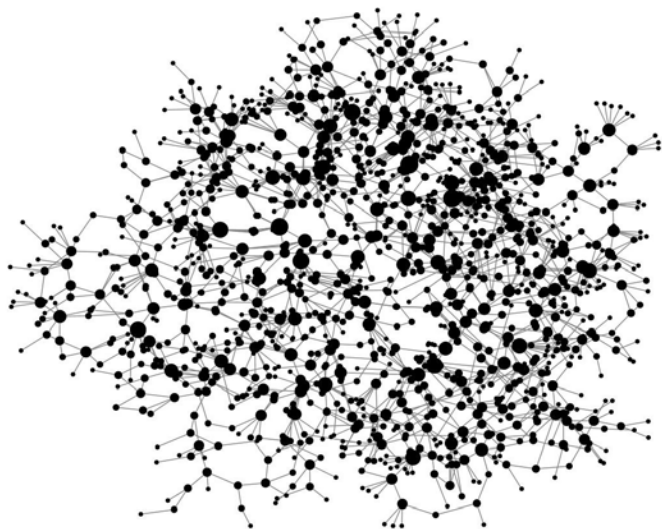

Fig. 5. Network structure of France power transmission network.

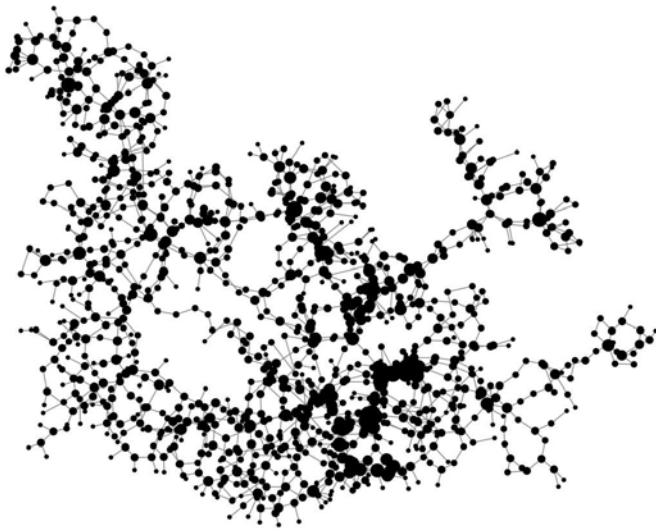

Fig. 6. Network structure of Germany power transmission network.



Fig. 7. Network structure of Italy power transmission network.

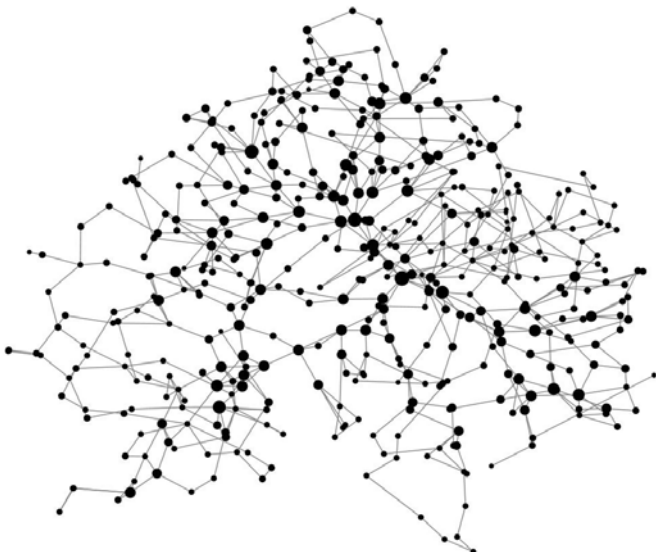

Fig. 8. Network structure of Spain power transmission network.

## REFERENCES

- [1] A. Clauset, C. Moore and MEJ Newman, "Hierarchical structure and the prediction of missing links in networks," *Nature*, vol. 453, no. 7191, pp. 98–101, 2008.
- [2] S. Valverde and R. V. Solé, "Self-organization versus hierarchy in open-source social networks," *Physical Review E*, vol.76 no. 4 pp. 046118, 2007.
- [3] H. Ma, J. Buer and A. Zeng, "Hierarchical structure and modules in the Escherichia coli transcriptional regulatory network revealed by a new top-down approach," *BMC bioinformatics*, vol. 5 no.1, pp. 1, 2004.
- [4] H. Yu and M. Gerstein, "Genomic analysis of the hierarchical structure of regulatory networks," *Proc. Natl. Acad. Sci. USA*, vol., 103 no.40, pp. 14724-14731, 2006.
- [5] M. Kaiser, C. C. Hilgetag and R. Kötter, "Hierarchy and dynamics of neural networks," *Frontiers in neuroinformatics*, vol. 4 no.112, 2010.
- [6] G. A. Pagani and M. Aiello, "The Power Grid as a Complex Network: a Survey," *Physica A*, vol. 392, no. 11, pp. 2688-2700, 2013.
- [7] J. Yan, H. He, and Y. Sun, "Integrated Security Analysis on Cascading Failure in Complex Networks," *IEEE Transactions on Information Forensics & Security*, vol. 9, no.9, pp. 451-463, 2014.
- [8] X. Zhang and C. K. Tse, "Assessment of Robustness of Power Systems From a Network Perspective," *IEEE Journal on Emerging & Selected Topics in Circuits & Systems*, vol. 5, no. 3, pp. 456-464, 2015.
- [9] V. Gol'dshtein, G. A. Koganov and G. I. Surdutovich, "Vulnerability and Hierarchy of Complex Networks," arXiv: preprint cond-mat 409298.
- [10] G. R. McGhee, *Theoretical Morphology. The Concept and Its Applications*. New York: Columbia Univ Press, 1999, pp.1.
- [11] O. Shoval, et al., "Evolutionary trade-offs, Pareto optimality, and the geometry of phenotype space," *Science*, vol. 336, no. 6085, pp. 1157-1160, 2012.
- [12] J. Goñi, et al., "Exploring the morphospace of communication efficiency in complex networks," *PLoS One*, vol. 8, no. 3, pp. e58070, 2013.
- [13] B. Corominas-Murtra, J. Goñi, R. V. Solé and C. Rodríguez-Caso, "On the origins of hierarchy in complex networks," *Proc. Natl. Acad. Sci. USA*, vol. 110, no.33, pp. 13316-13321, 2013.
- [14] D. Watts, *Small Worlds: The Dynamics of Networks between Order and Randomness*. Princeton University Press, 1999, pp. 1.
- [15] S. Boccaletti, V. Latora, Y. Moreno, M. Chavez and D. U. Hwang, "Complex networks: Structure and dynamics," *Physics Reports*, vol. 424, no. 4-5, pp. 175-308, Feb 2006.
- [16] L. da F. Costa, F. A. Rodrigues, G. Travieso and P. R. Villas Boas, "Characterization of complex networks: A survey of measurements," *Advances in Physics*, vol. 56, no. 1, pp. 167-242, 2007.
- [17] D. J. Watts and S. H. Strogatz, "Collective dynamics of 'small-world' networks," *Nature*, vol. 393, no. 6684, pp. 440-442, Jul. 1998.
- [18] E. Bompard, E. Pons and D. Wu, "Extended Topological Metrics for the Analysis of Power Grid Vulnerability," *IEEE Systems Journal*, vol. 6, no. 3, pp. 481-487, 2012.
- [19] J. D. Glover and M. Sarma, *Power system analysis and design*, 2<sup>nd</sup> ed., PWS Publishing Company, Boston, 1994.
- [20] B. Bollobas, *Modern Graph Theory*, Springer, 2002.
- [21] E. Bompard, R. Napoli and F. Xue, "Extended topological approach for the assessment of structural vulnerability in transmission networks," *IET Gener. Transm. Distrib.*, vol.4, no. 6, pp. 716-724, 2010.
- [22] E. Cotilla-Sanchez, P. D. Hines, C. Barrows, and S. Blumsack, "Comparing the topological and electrical structure of the North American electric power infrastructure," *IEEE Systems Journal*, vol. 6, no. 4, pp. 616–626, 2012.
- [23] R. Albert, I. Albert, and G. L. Nakarado, "Structural Vulnerability of the North American Power Grid," *Phys. Rev. E*, vol. 69, no. 2, pp. 25103, 2004.
- [24] R. Albert, H. Jeong, A. Barabasi, and A. L. Barabási, "Error and attack tolerance of complex networks," *Nature*, vol. 406, no. 6794, pp. 378–382, Jul. 2000.
- [25] D. Bienstock and A. Verma, "The N – k problem in power grids: New models, formulations, and numerical experiments," *SIAM J. Optimiz.*, vol. 20, no. 5, pp. 2352–2380, 2010.
- [26] I. Dobson, et al., "Complex systems analysis of series of blackouts: Cascading failure, critical points, and self-organization," *Chaos*, vol. 17, no.2, pp. 026103, 2007.
- [27] Motter AE and Lai YC, "Cascade-based attacks on complex networks," *Phys. Rev. E*, vol. 66, no. 6, pp. 065102, 2002.

- [28] P. Crucitti, V. Latora, and M. Marchiori, "A model for cascading failures in complex networks," *Phys. Rev. E*, vol. 69, no. 4, pp. 045104R, Apr. 2004.
- [29] S. Soltan, D. Mazauric, and G. Zussman, "Cascading failures in power grids: analysis and algorithms," in *Proceedings of the 5<sup>th</sup> international conference on Future energy systems, ACM*, 2014.
- [30] NodeXL: Network Overview, Discovery and Exploration [Online]. Available: <http://nodexl.codeplex.com/>
- [31] ENTSO major events statistics and data [Online]. Available: <https://www.entsoe.eu/publications/statistics/monthly-statistics/Pages/default.aspx> and <https://www.entsoe.eu/news-events/former-associations/ucte/monthly-statistics/Pages/default.aspx>

**Lingen Luo** received his M.S. degree in electrical engineering from Shanghai Jiao Tong University, Shanghai, China, in 2008 and received his Ph.D degree in electrical engineering from Politecnico di Torino, Italy, in 2014.

He is currently a staff researcher of Shanghai Jiao Tong University. His research interests are vulnerability analysis of power systems, smart grid and the application of complex networks in power systems.

**Bei Han** received M.S degree in electrical engineering from Shanghai Jiao Tong University and received Ph.D degree in electrical engineering from Politecnico di Torino. Currently, she is an Assistant Professor of Shanghai Jiao Tong University. Her research interests are complex distribution system modeling with multi-microgrids and DER uncertainties.

**Marti Rosas-Casals** received his Ph.D degree in applied sciences from the Universitat Politècnica de Catalunya - BarcelonaTech (Spain) in 2009.

He is currently Associate Professor with the Heat Engines Department at Universitat Politècnica de Catalunya – Barcelona Tech Terrassa School of Engineering, and head of the Sustainability Measurement and Modeling Lab (SUMMLab). His major fields are energy, infrastructure networks, and complex systems.