



NATIONAL DEFENSE RESEARCH INSTITUTE

THE ARTS
CHILD POLICY
CIVIL JUSTICE
EDUCATION
ENERGY AND ENVIRONMENT
HEALTH AND HEALTH CARE
INTERNATIONAL AFFAIRS
NATIONAL SECURITY
POPULATION AND AGING
PUBLIC SAFETY
SCIENCE AND TECHNOLOGY
SUBSTANCE ABUSE
TERRORISM AND
HOMELAND SECURITY
TRANSPORTATION AND
INFRASTRUCTURE
WORKFORCE AND WORKPLACE

This PDF document was made available from www.rand.org as a public service of the RAND Corporation.

[Jump down to document](#) ▼

The RAND Corporation is a nonprofit research organization providing objective analysis and effective solutions that address the challenges facing the public and private sectors around the world.

Support RAND

[Purchase this document](#)

[Browse Books & Publications](#)

[Make a charitable contribution](#)

For More Information

Visit RAND at www.rand.org

Explore [RAND National Defense Research Institute](#)

View [document details](#)

Limited Electronic Distribution Rights

This document and trademark(s) contained herein are protected by law as indicated in a notice appearing later in this work. This electronic representation of RAND intellectual property is provided for non-commercial use only. Unauthorized posting of RAND PDFs to a non-RAND Web site is prohibited. RAND PDFs are protected under copyright law. Permission is required from RAND to reproduce, or reuse in another form, any of our research documents for commercial use. For information on reprint and linking permissions, please see [RAND Permissions](#).

This product is part of the RAND Corporation monograph series. RAND monographs present major research findings that address the challenges facing the public and private sectors. All RAND monographs undergo rigorous peer review to ensure high standards for research quality and objectivity.

Networked Forces in Stability Operations

101st Airborne Division,
3/2 and 1/25 Stryker Brigades
in Northern Iraq

Daniel Gonzales, John Hollywood, Jerry M. Sollinger, James McFadden,
John DeJarnette, Sarah Harting, Donald Temple

Prepared for the Office of the Secretary of Defense
Approved for public release; distribution unlimited



NATIONAL DEFENSE RESEARCH INSTITUTE

The research described in this report was prepared for the Office of the Secretary of Defense (OSD). The research was conducted in the RAND National Defense Research Institute, a federally funded research and development center sponsored by the OSD, the Joint Staff, the Unified Combatant Commands, the Department of the Navy, the Marine Corps, the defense agencies, and the defense Intelligence Community under Contract DASW01-01-C-0004.

Library of Congress Cataloging-in-Publication Data

Networked forces in stability operations : 101st Airborne Division, 3/2 and 1/25 Stryker brigades in northern Iraq / Daniel Gonzales ... [et al.].

p. cm.

Includes bibliographical references.

ISBN 978-0-8330-4303-0 (pbk. : alk. paper)

1. Command and control systems—United States—Evaluation—Case studies.
2. Communications, Military—Evaluation—Case studies.
3. Stryker brigade combat teams—Evaluation—Case studies.
4. United States. Army. Airborne Division, 101st—History—21st century.
5. United States—Armed Forces—Stability operations—Evaluation.
6. Iraq War, 2003—Campaigns. I. Gonzales, Daniel, 1956–

UA943.N48 2007

956.7044'342—dc22

2007041879

Public release of this report was granted by the Chief of the DoD Office of Security Review on 17 September 2007, per DD Form 1910.

The RAND Corporation is a nonprofit research organization providing objective analysis and effective solutions that address the challenges facing the public and private sectors around the world. RAND's publications do not necessarily reflect the opinions of its research clients and sponsors.

RAND® is a registered trademark.

© Copyright 2007 RAND Corporation

All rights reserved. No part of this book may be reproduced in any form by any electronic or mechanical means (including photocopying, recording, or information storage and retrieval) without permission in writing from RAND.

Published 2007 by the RAND Corporation

1776 Main Street, P.O. Box 2138, Santa Monica, CA 90407-2138

1200 South Hayes Street, Arlington, VA 22202-5050

4570 Fifth Avenue, Suite 600, Pittsburgh, PA 15213-2665

RAND URL: <http://www.rand.org>

To order RAND documents or to obtain additional information, contact

Distribution Services: Telephone: (310) 451-7002;

Fax: (310) 451-6915; Email: order@rand.org

Preface

This case study report examines the network-centric operations (NCO) capabilities and the operations of Stryker brigades and the 101st Airborne Division that conducted stability operations in Iraq in the 2003 to 2005 time frame. We investigate how the NCO capabilities and other resources available to these units were utilized to conduct stability and counterinsurgency operations and whether these capabilities resulted in improved mission effectiveness.

The monograph should interest U.S. Army and joint task force designers, those concerned with the development of digital battle command and communications systems, and those interested in the implications of NCO for the transformation of military forces.

This research was sponsored by the Office of Force Transformation and conducted within the Acquisition and Technology Policy Center of the RAND National Defense Research Institute, a federally funded research and development center sponsored by the Office of the Secretary of Defense, the Joint Staff, the unified combatant commands, the Department of the Navy, the Marine Corps, the defense agencies, and the defense Intelligence Community.

For more information on RAND's Acquisition and Technology Policy Center, contact the director, Philip Antón. He can be reached by email, Philip_Anton@rand.org; by phone at 310-393-0411, ext. 7798; or by mail at RAND, 1776 Main Street, Santa Monica, California, 90407-2138. More information about RAND is available at www.rand.org.

Contents

Preface	iii
Figures	ix
Tables	xi
Summary	xiii
Acknowledgments	xxxv
Abbreviations	xxxvii
CHAPTER ONE	
Introduction	1
Background	1
Objectives	3
Analytic Approach	4
Sources of Information	9
Organization of Monograph	10
CHAPTER TWO	
Iraqi Operational Setting and Unit Characteristics	13
Characteristics of Anti-Iraqi Forces	16
Phases of the Insurgency	17
Unit Organization	18
Areas of Operation	20
AO Sizes, Personnel, Funding, and Attached Units	23
Timeline of Events	28
U.S. Casualties	36

CHAPTER THREE

Force Networking, Quality of Information, and Quality of Shared Situation

Awareness	39
Networking Systems	39
Effect of Networking Systems on Quality of Information	48
Specific Effects of Networking Systems on Quality of Information	54
Effect of Networking Systems on Quality of Collaboration	56
Quality of Shared Situation Awareness.....	58

CHAPTER FOUR

Tactical Stability Missions, NCO-Enabled Processes, and Tactical Mission

Effectiveness	65
Tactical Military Operations in Stability Operations.....	65
NCO-Enabled Processes	68
Speed and Agility of Command.....	69
Responsive Maneuver.....	72
Networking with Aerial Support and Surveillance Assets	74
Robustness to Enemy Attack	75
Stability Operations Intelligence Needs.....	91

CHAPTER FIVE

Mission Effectiveness in Stability Operations	95
U.S. Strategic Objectives and MNF–I Campaign Plan	95
Assessment Framework	98
Assessment of Effectiveness—Political Progress.....	101
Assessment of Effectiveness—Defeating Terrorists and Containing the Insurgency	108
Summary of Mission Effectiveness.....	123

CHAPTER SIX

Summary: Findings and Recommendations	129
Assessment of 101st ABD Mission Effectiveness in Stability Operations	129
Assessment of 3/2 SBCT Mission Effectiveness in Stability Operations	133
Assessment of 1/25 SBCT Mission Effectiveness in Stability Operations.....	136
Role of NCO Capabilities in Improving Force Effectiveness in Stability Operations	139
Summary of Network and Intelligence Capabilities.....	142

Additional Findings..... 144
Recommendations 145

APPENDIX

A. Director, Office of Force Transformation, Study Authorization Memorandum ... 147
B. SBCT Tactics, Techniques, and Procedures Used in OIF 151
C. Detailed Results of the Quality of Information and Collaboration Surveys 161
D. Iraqi National Elections 165

Bibliography..... 171

Figures

S.1.	Civilians Killed in All of Iraq and in Mosul	xv
S.2.	U.S. Personnel Killed and Wounded in Action per Enemy Attack.....	xvi
S.3.	U.S. Personnel Killed and Wounded in Action per Offensive Operation	xviii
S.4.	Key Factors Influencing 101st ABD Performance in Stability Operations	xviii
S.5.	Key Factors Influencing 3/2 SBCT Performance in Stability Operations	xxii
S.6.	Key Factors Influencing 1/25 SBCT Performance in Stability Operations.....	xxv
S.7.	Adaptation of Materiel and Nonmateriel NCO Force Elements.....	xxix
1.1.	NCO Conceptual Framework	6
1.2.	NCO Analysis Approach	8
2.1.	The “Sunni Triangle” and U.S. Unit Operating Areas.....	14
2.2.	Locations of Frequent U.S. Military Casualties Between May 2003 and July 2005	15
2.3.	101st ABD, 3/2 SBCT, and 1/25 SBCT Organizational Structures.....	19
2.4.	101st ABD and 3/2 SBCT Area of Operations	21
2.5.	The 1/25 SBCT Area of Operations.....	22
2.6.	Causes of Death for U.S. Troops	31
2.7.	U.S. Military Casualties in OIF since March 19, 2003.....	37
3.1.	101st ABD Infantry Brigade Network	40
3.2.	3/2 SBCT Communications Network.....	42
3.3.	IKSS Network.....	44
3.4.	UAV Imagery Received by Rover III	45
3.5.	Predator Control Using Rover III and SIPRNET MIRC	46
3.6.	C2/BC Systems	47
3.7.	Quality of Information for Cordon-and-Search and Knock-and-Raid Missions.....	52
3.8.	Quality of Information for Convoy Missions	53
3.9.	Survey Results on Quality of Collaboration.....	57

4.1.	Timeline for Major Operations in Northern Iraq	68
4.2.	An Order-of-Magnitude Increase in Speed and Agility of Command	70
4.3.	SBCT Task Force’s Movement to Najaf	73
4.4.	Map of Mogadishu and Initial Position of Assault Forces	78
4.5.	Timeline of the Battle of Mogadishu	80
4.6.	Timeline for the Tal Afar Incident	85
5.1.	Multi-National Forces–Iraq Campaign Plan	97
5.2.	Enemy Attacks—Theaterwide and in AO North	110
5.3.	Percentage Change in Enemy Attacks During Each Unit’s Rotation.	111
5.4.	Civilian KIAs for All of Iraq and for Mosul	112
5.5.	Offensive Operations per Enemy Attack for the 101st ABD, 3/2 SBCT, and 1/25 SBCT	117
5.6.	U.S. KIA and WIA per Enemy Attack	118
5.7.	U.S. KIA and WIA per Offensive Operation	118
5.8.	Number of IEDs and Weapons Caches Found per Enemy Attack for the 101st ABD, 3/2 SBCT, and 1/25 SBCT	122
5.9.	Influence of Network-Enabled Capabilities on Stability Operations	126
6.1.	Key Factors Influencing 101st ABD Performance in Stability Operations	130
6.2.	Key Factors Influencing 3/2 SBCT Performance in Stability Operations	134
6.3.	Key Factors Influencing 1/25 SBCT Performance in Stability Operations	137
6.4.	Adaptation of Materiel and Nonmateriel NCO Force Elements	141
B.1.	Cover of the 1/25 SBCT’s Leaders Agility Book	152
C.1.	Detailed Quality of Information Results for Cordon-and-Search/ Knock-and-Raid Operations	162
C.2.	Detailed Quality of Information Results for Convoy Operations	163
C.3.	Detailed Quality of Collaboration and Shared Situation Awareness Results	164
D.1.	Iraqi National Election System for the Constitutional Referendum	166
D.2.	Results of the Iraqi Constitutional Referendum	168

Tables

S.1.	U.S. Stability Objectives	xiv
S.2.	Summary of SBCT Networking and Battle Command Enhancements	xxx
2.1.	Unit Areas of Operation, Resident Iraqi Populations, U.S. Troop Levels, and Attached ING Units	24
3.1.	NCO Enhancements in Northern Iraq	49
3.2.	Breakdown of Survey Responses by Rank and Unit Role	51
3.3.	Summary of Units' Shared Situation Awareness	63
4.1.	Battle of Mogadishu Total Mission Casualties	83
4.2.	Battle of Tal Afar Total Mission Casualties	88
4.3.	Forces Employed in the Battle of Tal Afar and Mogadishu	90
5.1.	U.S. Strategic Goals in Iraq	96
5.2.	Political Goal Assessment Measures	98
5.3.	Security Goal Assessment Measures	100
5.4.	Summary of Political Progress Assessment for 101st ABD	101
5.5.	Summary of Political Progress Assessment for 3/2 SBCT	103
5.6.	Summary of Political Progress Assessment for 1/25 SBCT	106
5.7.	Casualty Rates for the 101st ABD and 3/2 SBCT	116
5.8.	Mission Effectiveness Assessment Summary	124
6.1.	Summary of Networking and Battle Command Enhancements	143

Summary

Background

The Stryker brigade, one of the Army's newest units, has advanced command, control, and intelligence capabilities and uses a network-centric concept of operations. These capabilities include the full complement of Army digital communications and battle command systems. Its networked capabilities enabled it to employ network-centric operations (NCO) capabilities down to a lower echelon than other Army units. An important issue for the Department of Defense and the Army is whether these improved capabilities translate into an information advantage and, if so, whether that advantage results in greater mission effectiveness in stability operations.

Purpose and Approach

This study attempts to answer those two questions by focusing on the Stryker brigade's performance in stability operations. It employs the case-study methodology to examine three units that operated in the same area in Iraq between 2003 and 2005: the 101st Airborne Division (ABD), the 3/2 Stryker brigade combat team (SBCT), and the 1/25 SBCT. All served in Iraq's northern provinces. The study compares the performance of the units along a number of dimensions. The comparisons between the 101st ABD and the Stryker brigades are especially important because, although the 101st ABD had some advanced battle command systems, it was largely an "analog" unit, i.e., one that communicated using analog radios and generally used voice-only, line-of-sight communications at the tactical level. In many respects, the units of the 101st ABD closely resemble light infantry brigades. In contrast to the 101st ABD, Stryker units had networked digital communications networks and access to high-capacity satellite

communications at lower echelons, which enabled them to communicate even when units did not have line of sight between them.

We recognize the issues inherent in the methodology and in the specific comparisons we make. Case studies are essentially qualitative comparisons, although they can be informed by quantitative information. Additionally, they are analogies because in real-world operations the cases are not identical. We also recognize that the situations confronting the three units differed substantially, even though all three units operated in the same provinces in Iraq. The 101st ABD was there shortly after major combat operations (MCO) concluded but before the insurgency had hit full stride. Furthermore, the two Stryker brigades did not have identical sets of equipment. The 1/25 SBCT had more enhanced communications and intelligence capabilities than did the 3/2 SBCT. That said, we believe that the methodology can shed light on the performance of the two types of units and on how network-centric capabilities affect unit performance.

We use two of the four U.S. objectives for stability and reconstruction in Iraq (see Table S.1) to assess the mission effectiveness of stability operations undertaken by each unit.

Table S.1
U.S. Stability Objectives

Political	Forge a broadly supported national concept for democratic governance
Security	Defeating terrorists and containing insurgents

Civilian Deaths

Figure S.1 plots reported civilians killed in action (KIAs) by month for all of Iraq and for Mosul. As shown, the number of civilian KIAs per month surged in June 2004 and remained roughly flat or increased slightly thereafter throughout Iraq as a whole. The data indicate that there has not been any sustained reduction in civilian casualties in Iraq overall after the peaks in February and August 2005.

Before we turn to a detailed examination of each unit’s performance, we look at trends in civilian and U.S. casualties in Iraq and in northern Iraq.

Figure S.1
Civilians Killed in All of Iraq and in Mosul

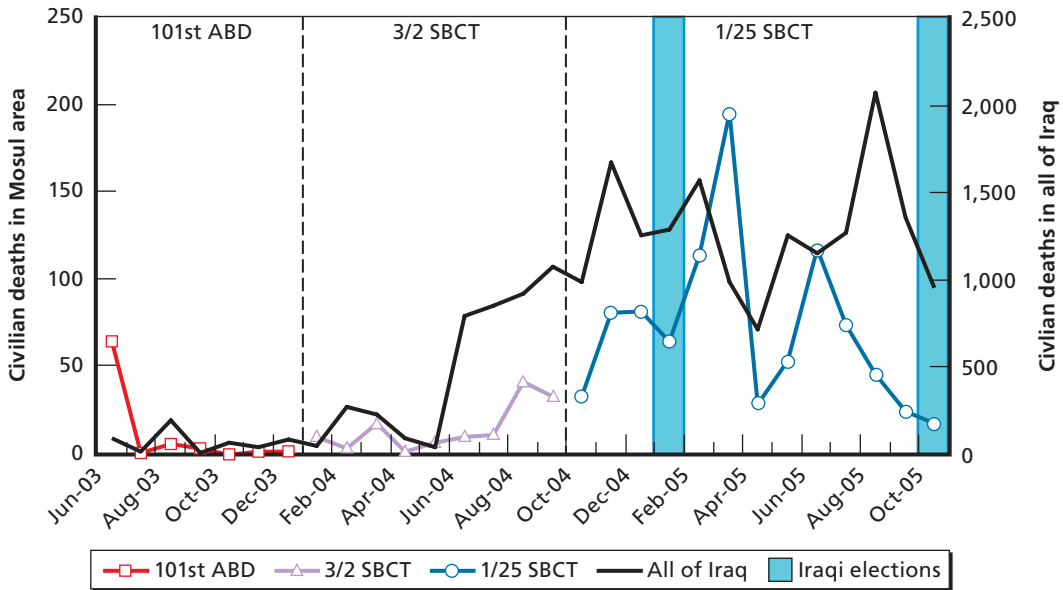

RAND MG593-S.1

Figure S.1 also plots reported civilian KIAs for Mosul and indicates when each unit operated in Mosul and elsewhere in northern Iraq. In comparison with civilian KIAs elsewhere in Iraq, civilian KIAs in Mosul fall off sharply after June 2005. This pattern is consistent with reports that the 1/25 SBCT defeated a major insurgent offensive in Mosul, captured key insurgent leaders, and disrupted insurgent operations.

U.S. Casualties Adjusted for Operational Tempo

Figures S.2 and S.3 show order-of-magnitude reductions in casualty rates for both Stryker brigades relative to both the 101st ABD and other units in Iraq at the same time, when operational intensity (both enemy and U.S.) factors are taken into account. These results reflect the growing intensity of Stryker brigade operations in response to attacks as the insurgency grew over time. Note that the 1/25 SBCT casualty rates

Figure S.2
U.S. Personnel Killed and Wounded in Action per Enemy Attack

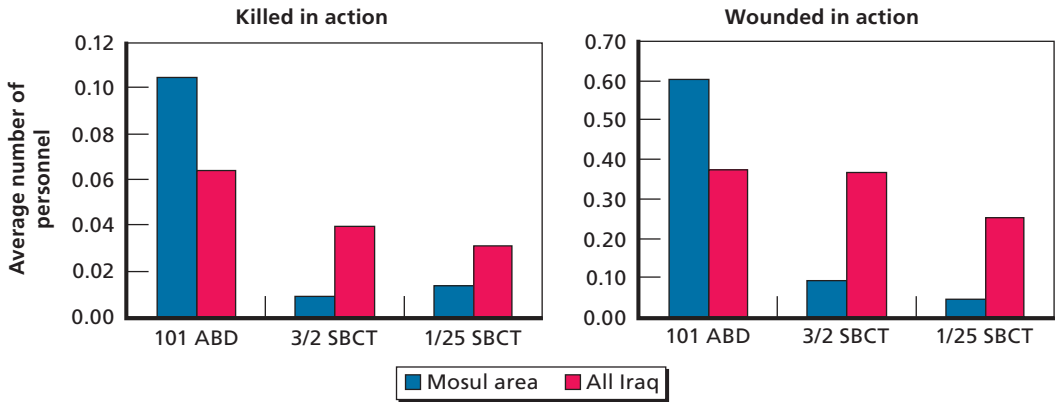

RAND MG593-S.2

Figure S.3
U.S. Personnel Killed and Wounded in Action per Offensive Operation

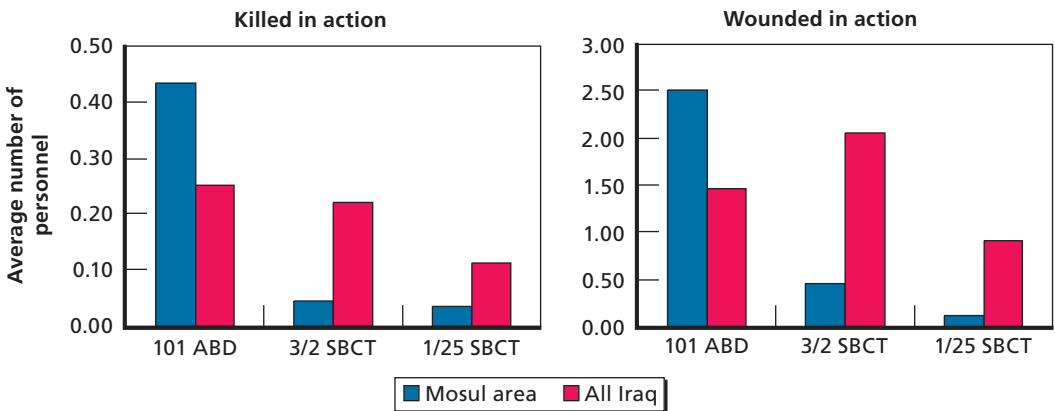

RAND MG593-S.3

(adjusted for operational tempo [OPTEMPO] and enemy attacks) are the lowest of all units in Area of Operation (AO) North.

Our analysis of SBCT tactical defensive operations indicates the SBCT's combined materiel improvements (Force XXI Battle Command Brigade and Below (FBCB2) and digital communications) and nonmateriel improvements (doctrine; tactics, techniques, and procedures [TTPs]; training) led to significant improvements in blue force quality of information and situation awareness. In some cases, the SBCTs were able to capitalize on improved blue force awareness to execute a number of advanced tactics, including accelerated planning, dynamic force retasking, self-synchronization, and swarming, which in turn led to improvements in performing tactical defensive missions. The SBCTs displayed a robust dynamic response to enemy ambushes and attacks.

The 1/25 SBCT also used these advanced tactics, new networked intelligence capabilities, and decentralized operations to conduct targeted raids that enabled Stryker units to respond quickly and effectively to intelligence tips. Further, these new intelligence capabilities were integrated into the tactical capabilities of 1/25 SBCT units.¹ These operations would not have been possible without the SBCTs' information and networking capabilities embedded at the tactical level.²

Assessment of 101st ABD Mission Effectiveness

Figure S.4 summarizes the materiel and nonmateriel factors contributing to the performance of the 101st ABD in Iraq. From a communications network technology perspective, the 101st ABD benefited from having FBCB2–Blue Force Tracking (FBCB2-BFT) systems on some command and control (C2) vehicles and many helicopters (68 ground systems and 88 aviation systems). The rest of its systems were the Army's standard issue—they relied on mobile subscriber equipment (MSE) and near-term digital radio (NTDR) legacy equipment for communications and the All Source Analysis System (ASAS) and other legacy systems for intelligence, surveillance, and reconnaissance.

¹ See the classified annexes to this monograph for further details.

² The conclusions we reach here are similar to those identified independently in Robert D. Kaplan, "The Coming Normalcy?" *The Atlantic Monthly*, Vol. 297, No. 4, April 2006, pp. 72–81.

Figure S.4
Key Factors Influencing 101st ABD Performance in Stability Operations

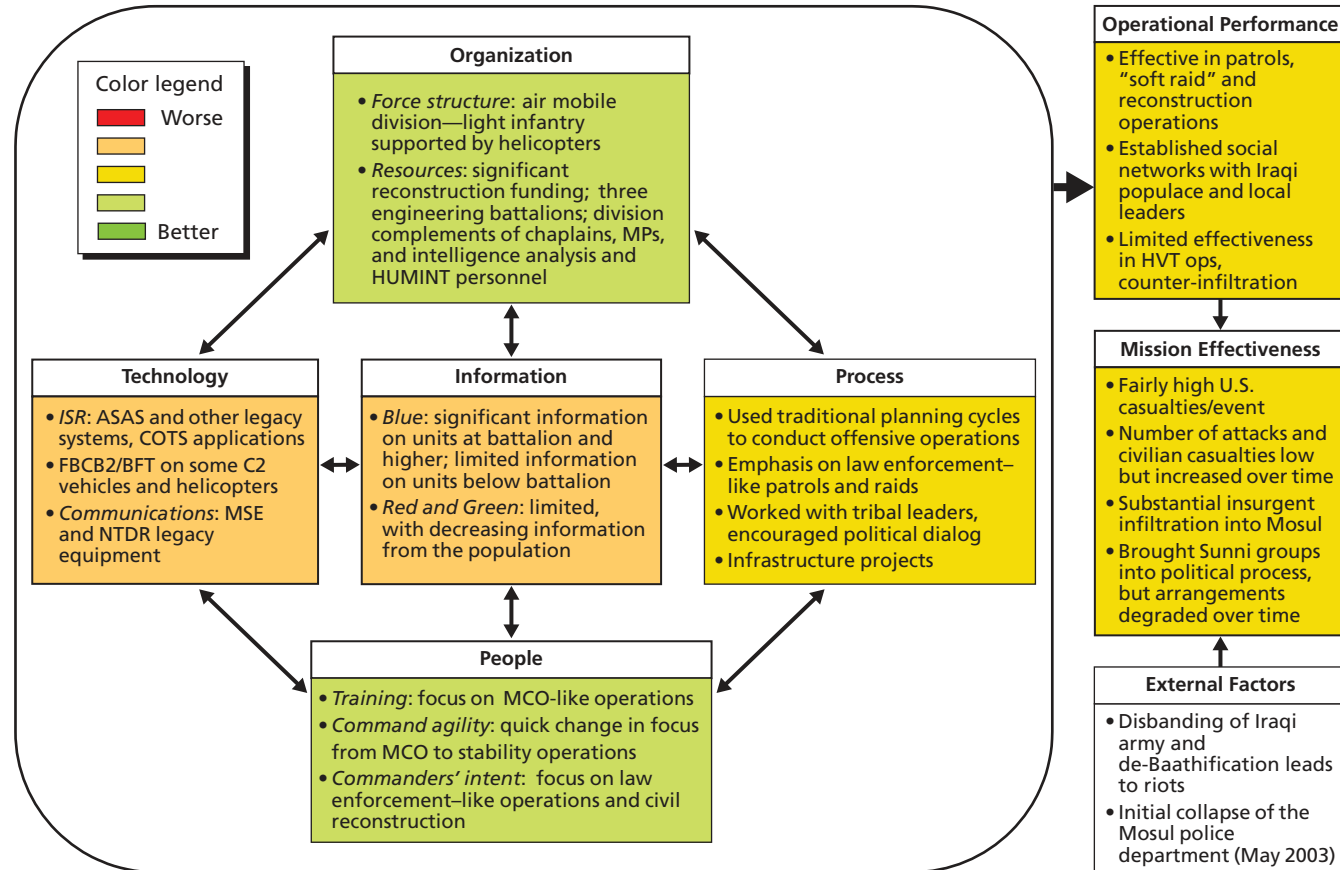

RAND MG593-S.4

From an organizational perspective, the 101st ABD is as an air-mobile division, comprising light infantry supported by helicopters, with about 17,000 troops total. In comparison, the Iraqi province in which they operated most heavily, Ninawah, has a population of about 2.5 million (with Mosul having a population of about 1.8 million), for a total force ratio of about 6.8 soldiers per thousand residents; historically, this ratio is at the edge of the force size needed to conduct a stability operation.³ Note that this force ratio does not include security forces that were hired, equipped, and trained by U.S. forces (regional police and new Iraqi Army forces). We do not include these forces in the force presence ratio for several reasons: First, their numbers could not be accurately ascertained because they changed significantly from month to month. Second, the reliability and experience of these forces varied significantly depending upon the unit and the time in question.

The 101st ABD also had more than \$31 million in reconstruction funding available (about \$12,400 per thousand residents), along with three engineering battalions available to support reconstruction activities. The unit also had a division complement of chaplains and military police available for liaison activities and a division complement of intelligence personnel, including tactical human intelligence (HUMINT) teams.

Before Operation Iraqi Freedom (OIF), the 101st ABD's training had focused on major combat operations. However, once those operations were over and reconstruction began, the commanders' intent rapidly switched to a focus on civil reconstruction and conducting law enforcement-like operations to provide security. Consequently, even though the unit as a whole had not trained for stability operations, the commanders of the 101st ABD were able to reorient their soldiers to conduct stability operations relatively well, without the excessive use of combat power and without generating large-scale animosity among the populace.

The reorientation of the 101st ABD included stability-specific processes that emphasized law enforcement-like patrols and "soft" raids (for example, knocking on doors rather than barging into homes), and heavy spending on reconstruction projects performed by local contractors. In addition, there was substantial command emphasis

³ James Quinlivan conducted a historical analysis of the force ratios required to conduct stability operations. He found that, historically, ratios of one to four soldiers per thousand residents were sufficient strictly for routine policing (such as in post-World War II Germany); ratios of four to ten per thousand could be adequate, but at the cost of carrying out harshly punitive actions; and ratios of ten or more per thousand were the norm for stability operations. (See "Force Requirements in Stability Operations" *Parameters*, Winter 1995, pp. 59–69.)

on social networking with tribal leaders to bring Sunni groups into the political process, making good use of reconstruction funding to do so.

Many security operations, however, had to be conducted using lengthy (usually daylong) planning cycles. Leaders of the 101st ABD had to arrange face-to-face meetings to conduct planning because of a lack of widespread real-time mobile communications. The division also had only limited voice combat net radio systems to monitor operations and respond dynamically.

From an information perspective, the 101st ABD's FBCB2-BFT systems provided significant information on units at the battalion level and higher. However, the 101st ABD had very limited real-time information on units below battalion level. Stability and counterinsurgency operations have been characterized as small-unit operations—company and below. The 101st ABD also had limited information on enemy forces and the civilian ("green") population. It had limited tools for collecting and analyzing intelligence, and the flow of information from the population appears to have decreased over time as population groups (notably Sunnis) became more hostile to the occupation.

The 101st ABD performed well in conducting reconstruction and some types of security operations. They were reportedly effective in conducting distributed patrols and "soft raids" and in initially building social networks with the population. However, raids against adaptive insurgent leaders were less effective at counter-infiltration.

The 101st ABD did have a high number of U.S. casualties per attack or coalition operation, but many local Sunnis were brought into the political process and a local multiethnic governing council was formed. From a stability perspective, the number of enemy attacks and civilian casualties remained low during the 101st ABD's deployment but increased steadily over time. As time went on, there was substantial insurgent infiltration into Mosul. Further, while Sunni groups initially took an active part in the political process, this activity lessened. The major external factors further hampering the 101st ABD's effectiveness were widespread de-Ba'athification and the Coalition Provisional Authority's (CPA's) disbanding of the Iraqi army; these decisions triggered riots and the first collapse of the Mosul police department in May 2003. Repercussions from the coalition force operations in Fallujah also lessened Sunni participation, especially given Arab media accounts of what happened there in the summer and fall of 2004.

Assessment of 3/2 SBCT Mission Effectiveness

Figure S.5 summarizes the materiel and nonmateriel factors contributing to the performance of the 3/2 SBCT in Iraq. From a technology perspective, the 3/2 SBCT enjoyed several significant advantages over the 101st ABD. It had the FBCB2–Enhanced Position Location Reporting System (EPLRS) on most platforms, allowing visibility and messaging with most tactical units. It also had a high-bandwidth satellite communications (SATCOM) network, the Interim Ku-band Satellite System (IKSS), to provide communications between the brigade’s battalion-level units and higher headquarters.

From an organizational perspective, however, the 3/2 SBCT had many fewer resources. Its structure is similar to that of an infantry brigade, with the addition of a reconnaissance, surveillance, and target acquisition (RSTA) squadron and military intelligence company—about 5,000 troops total. With respect to Ninawah province, this meant the force ratio decreased to about two soldiers per thousand residents, which is far below the level historically needed for stability operations.⁴ This ratio was further worsened by the fact that the 3/2 SBCT was the Multi-National Corps–Iraq’s (MNC-I’s) reserve force of choice, and frequently had company- or battalion-sized task forces conduct operations outside of northern Iraq. The 3/2 SBCT also had many fewer military police (MPs), chaplains, and engineers available than the 101st ABD and had many fewer intelligence analysts than a full division.

The 3/2 SBCT also had many fewer financial resources than the 101st ABD. They initially were given only a brigade-sized slice of reconstruction funding, despite being responsible for the same area of responsibility as the 101st ABD. Thus, the money initially available per thousand residents was less than one-third of what it was under the 101st ABD. Further, by the time the 3/2 SBCT was deployed to the theater, the CPA controlled nearly all reconstruction funding. The CPA was reportedly very slow to disburse reconstruction funds. This and the reduced funding resulted in the suspension or cancellation of many promised reconstruction projects. Some funding was eventually restored, and by the end of the rotation, the 3/2 reported distributing over \$15 million in reconstruction funds; however, this amount is still less than half of what it had been under the 101st ABD (\$6,000 per thousand residents versus \$12,400 per thousand).⁵

⁴ This force ratio does not include Iraqi security forces. We do not include these forces in the force presence ratio because of reasons cited above.

⁵ COL Michael Rounds, USA, “Arrowhead Brigade Combat Team in OIF I and II,” PowerPoint presentation, November 16, 2004, not available to the general public.

Figure S.5
Key Factors Influencing 3/2 SBCT Performance in Stability Operations

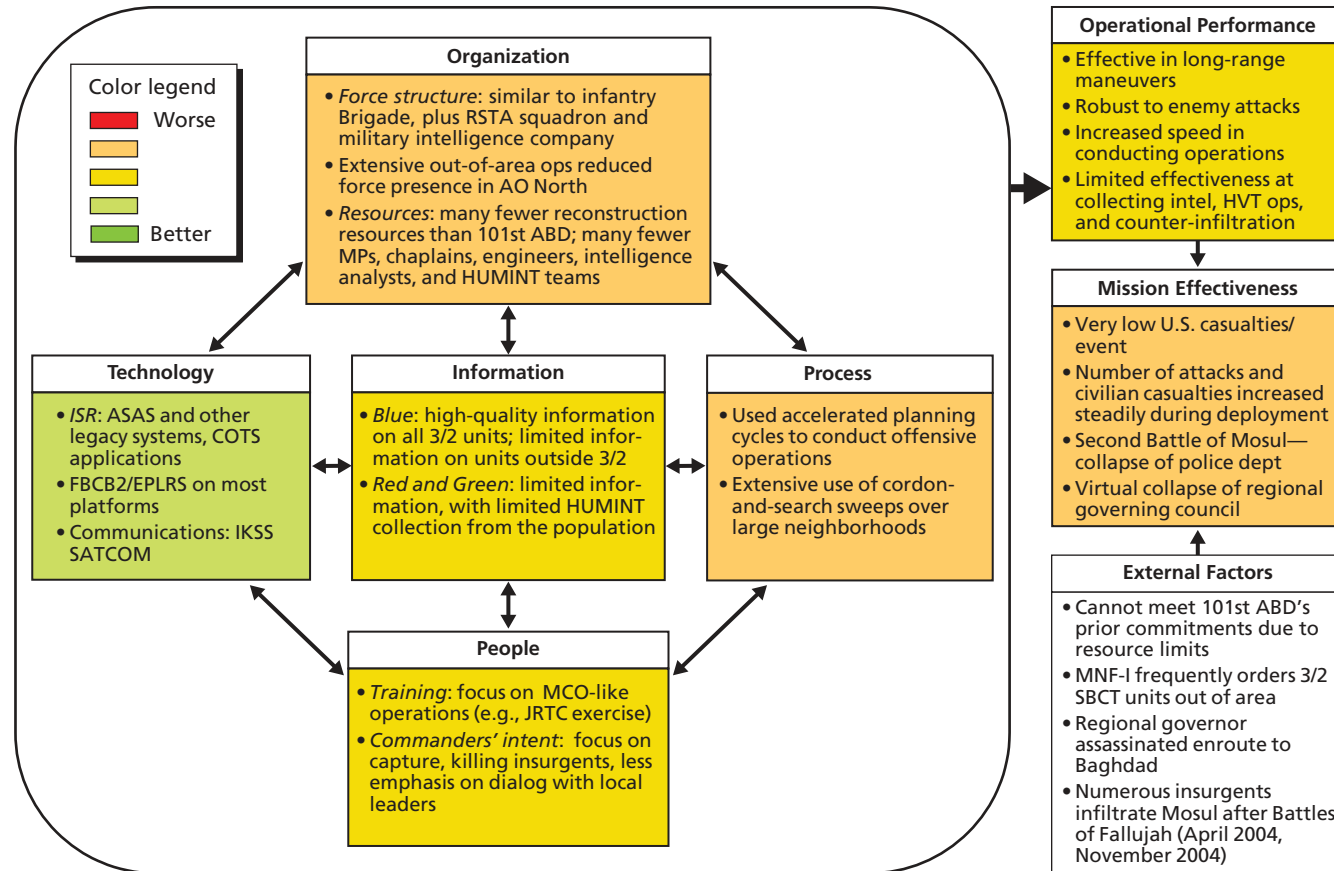

RAND MG593-S.5

From a people and process perspective, the 3/2 SBCT utilized major combat-like operations frequently in stability operations. When conducting these operations, it used advanced tactics, such as accelerated planning cycles for conducting offensive operations. It also used high-density FBCB2 systems to conduct dynamic C2 of operations for adaptive maneuver when deployed in out-of-area operations in central and southern Iraq. However, from a stability-specific operations perspective, the 3/2 SBCT's heavy emphasis on major combat-like operations, including frequent neighborhood sweeps, did not aid in building relations with the local population.

From an information perspective, the 3/2 SBCT had significant information on all units within the brigade down to the tactical level, although it continued to have limited information on units outside the 3/2 SBCT. Information on enemy forces and the civilian population continued to be low, with limited information collected from the population.

The 3/2 SBCT performed well in major combat-like operations when they were needed, including long-range maneuvers for out-of-area operations. It accelerated cycle times for conducting offensive operations and responded effectively to enemy attacks. However, the SBCT's limited effectiveness at collecting intelligence from the population hampered efforts at counter-infiltration and its conduct of targeted operations or raids against high-value targets. In addition, many of its cordon and search-and-sweep operations of Mosul neighborhoods appear to have been counterproductive and probably generated considerable resentment and distrust of coalition forces.

Consequently, with respect to effectiveness, we assess that the 3/2 SBCT did well on key MCO measures, such as casualties—it had extremely low U.S. casualties per event. However, with respect to security objectives for stability operations, the number of attacks and civilian casualties increased steadily throughout the deployment, culminating in the collapse of local police forces in Mosul shortly after the 3/2 SBCT's deployment (November 2004) and in the de facto collapse of the regional governing council earlier in 2004. The 3/2 SBCT's effectiveness was also dramatically hampered by two external factors. First, the 101st ABD had made many commitments to local residents and leaders concerning reconstruction projects; but without the 101st ABD's resources, the 3/2 SBCT could not honor these commitments, leading to significant resentment. Second, the first and second battles of Fallujah in 2004 strongly degraded security in Mosul, both due to Sunni outrage at the battles and at the perceived treatment of Sunni civilians in Fallujah and to the thousands of insurgents who fled Fallujah and set up operations in Mosul.

Assessment of 1/25 SBCT Mission Effectiveness

Figure S.6 summarizes the factors contributing to the 1/25 SBCT's performance in stability operations. From a technology perspective, the 1/25 SBCT began with the 3/2 SBCT's complement of FBCB2 and IKSS SATCOM and added several improvements. For intelligence, surveillance, and reconnaissance (ISR), the unit had new signals intelligence (SIGINT) equipment and Rover III/IV systems, providing a video link between air platforms and ground commanders. For communications, the unit added "TeamSpeak" voice-over-IP conferencing, which allowed all battalion-level units to participate in commanders' conferences. The 1/25 SBCT was also augmented with new networked SIGINT capabilities.

From an organizational perspective, the 1/25 SBCT had many fewer troops than the 101st ABD and lacked the division's reconstruction resources (the 1/25 SBCT, too, had only a brigade-sized share of reconstruction funds); however, it was not stretched as thin as the 3/2 SBCT. The 1/25 SBCT conducted few out-of-area operations, and substantial portions of another unit (the 3rd Armored Combat Regiment [ACR]) operated in Tal Afar and provided security along the Iraqi-Syrian border in Ninawah province during the latter half of the 1/25 SBCT's deployment, enabling the 1/25 SBCT to focus on Mosul and surrounding towns. Thus, the force presence ratio in Ninawah province increased from about two soldiers per thousand residents at the beginning of the 1/25 SBCT's rotation to about four soldiers per thousand at the end of its rotation. However, because the majority of the population of the province lived in Mosul, the 1/25 SBCT force presence ratio in the city was still about 2.8 soldiers per thousand residents.⁶

From a people perspective, both the training of personnel and the commanders' intent focused heavily on stability operations. Unlike the other two units, the 1/25 SBCT benefited from stability operations training in the United States prior to deployment. Like the 101st ABD, the 1/25 SBCT processes emphasized social networking tactics to engage the civilian population. It used distributed, law enforcement-like operations, with the dynamic C2 of these operations aided by FBCB2. It also

⁶ As before, this force ratio does not include Iraqi security forces.

Figure S.6
Key Factors Influencing 1/25 SBCT Performance in Stability Operations

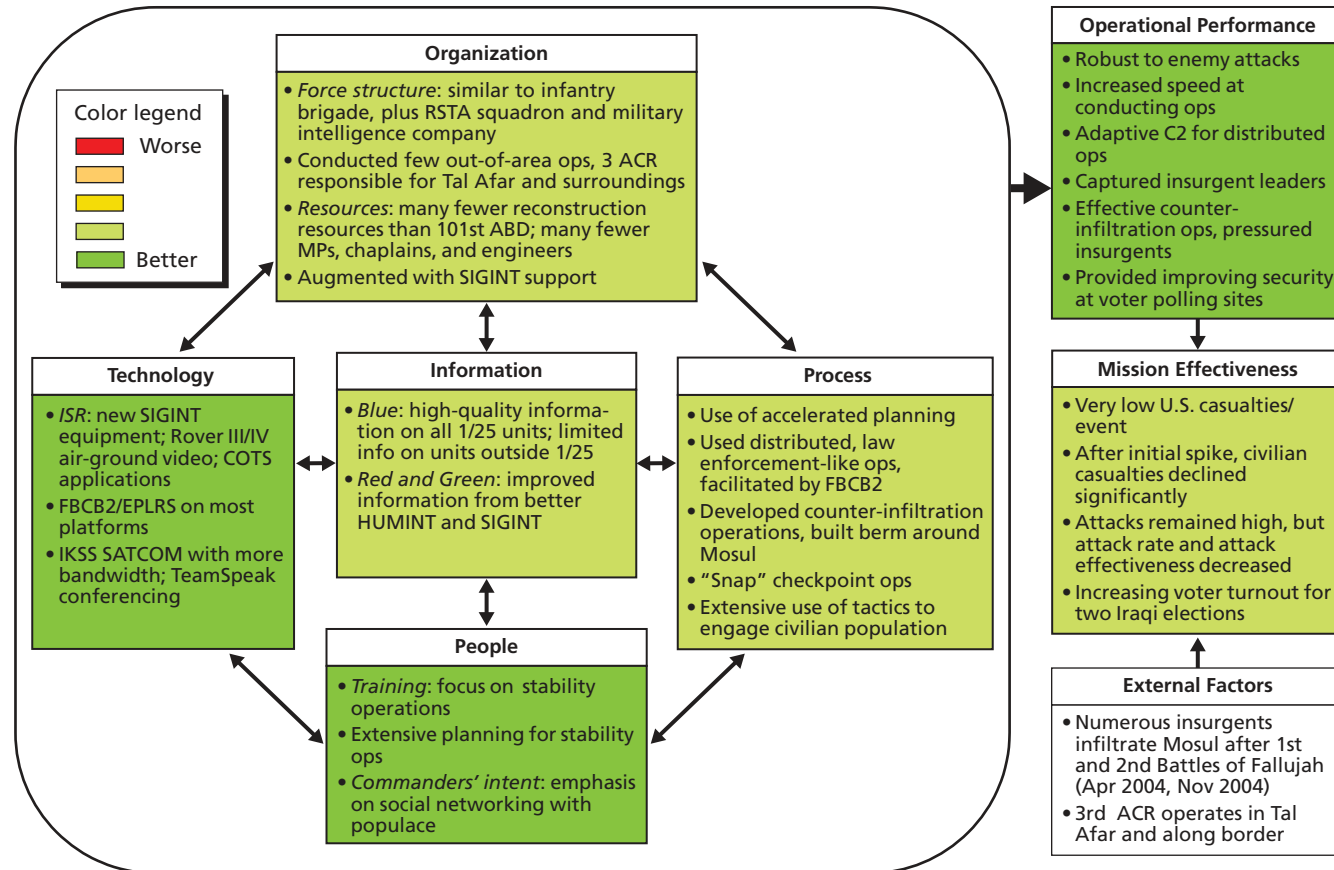

RAND MG593-S.6

developed additional counter-infiltration processes, such as extensive use of randomized checkpoint operations (“snap” traffic control points), constructed a berm around the entire city of Mosul, and provided real-time surveillance of the berm to capture insurgents attempting to infiltrate the city. In addition, the 1/25 SBCT retained the 3/2 SBCT’s accelerated planning and dynamic C2 capabilities, which were judged to be important in minimizing casualties.

From an information perspective, the 1/25 SBCT, like the 3/2 SBCT, had significant information on its units and limited information on outside units. It also had significantly improved information on enemy forces and the local population because of a significant increase in HUMINT, tips from the local population, and greatly enhanced SIGINT capabilities.

The 1/25 SBCT performed the security aspects of stability operations well and effectively supported local governance. Like the 3/2 SBCT, the 1/25 SBCT conducted offensive operations significantly faster and was robust against enemy attacks. The 1/25 SBCT used its dynamic mobile C2 for conducting distributed small-unit operations and could immediately redirect forces to offensive opportunities without advance planning. The 1/25 SBCT was effective at a variety of counter-infiltration operations and operations against high-value targets, putting significant pressure on insurgents and capturing two levels of insurgent leadership in Mosul. The 1/25 SBCT also provided improved security at voter polling sites during 2005. Equally important, it helped to reestablish political dialog between different ethnic groups and tribes.

Consequently, with respect to overall mission effectiveness and taking into account the larger and more lethal insurgency present in Iraq at the *start* of the 1/25 SBCT rotation, we assess the 1/25 SBCT as being effective at all aspects of stability operations addressed in this study: It contributed positively to political progress by reestablishing a multiethnic regional governing council. After an initial spike, civilian casualties declined significantly, enemy attacks declined by a small amount, and these attacks became much less effective. The 1/25 SBCT defeated a major insurgent offensive to seize Mosul, despite the infiltration of thousands of insurgents into the city after the first and second battles of Fallujah, and provided effective security for two Iraqi elections. Like the 3/2 SBCT, the 1/25 SBCT had very low U.S. casualties per event.

In summary, the 1/25 SBCT significantly improved the security situation in Mosul. Indeed, Robert Kaplan, an experienced war correspondent who traveled with elements of the 1/25 SBCT, wrote that normalcy seemed to be coming to Mosul and the surrounding area:

Mosul is a success story, although the success is relative, partial, and tenuous. The credit for what success there has been belongs to one of the U.S. Army's Stryker brigade combat teams that recently departed Iraq: the 1st Brigade of the 25th Infantry Division.⁷

Role of NCO Capabilities in Improving Force Effectiveness in Stability Operations

Our analysis indicates that command leadership, training, and TTPs, or the processes employed in stability operations, are just as important as networking technologies in improving mission effectiveness in stability operations.

We found the 1/25 SBCT and 101st ABD performed best overall in the stability phase in northern Iraq. The 101st ABD and 1/25 SBCT employed some of the same TTPs that were important in capturing insurgents and, for the 1/25 SBCT, in capturing high-level insurgent leaders. In the case of the 1/25 SBCT, these operations were carried out using digital networking and intelligence systems at the lowest tactical level. The 3/2 SBCT did not perform as well as the 1/25 SBCT, even though it was equipped with some of the same digital networking capabilities. Some of the TTPs the 3/2 SBCT employed, such as sweeps, widened the gulf between coalition forces and the local populace. In some cases, these tactics may have caused some Iraqi civilians to side with the insurgency. From this we can surmise that the benefits of networking technologies can be overridden by TTPs that are counterproductive in stability operations.

Equally important was effective social networking with the local populace and civilian leaders. Again, the 101st ABD and the 1/25 SBCT were the most effective in achieving political progress. Commanders of both the 1/25 SBCT and the 101st ABD emphasized social networking. Most social networking with the Iraqi populace and local leadership appears to have been carried out in face-to-face conversations and meetings. Military networking technologies had a minimal role here.

Many external factors, including the availability of reconstruction funds, affected the complex and changing political and security situation in northern Iraq. All three units were subject to such external factors, which were beyond their control. In this

⁷ Kaplan, 2006.

regard, the two Stryker brigades were at a clear disadvantage relative to the 101st ABD. They had reduced funding for reconstruction and fewer key liaison personnel (military police and chaplains), and they experienced other problems that either worsened the security situation or worsened how the coalition forces were perceived by the populace.

Finally, even with the deployment of the 3rd ACR to Ninawah province in the latter part of 2005, the 1/25 SBCT had a force presence ratio of only about 2.8 per thousand in Mosul, less than half what the 101st ABD had in the province as a whole. In this regard—“boots on the ground”—the 3/2 SBCT was at the greatest disadvantage of the three units. Nevertheless, given the smaller size of the 1/25 SBCT and the challenging security environment it inherited from its predecessors in northern Iraq, the performance of the 1/25 SBCT is remarkable.

We cannot quantify and isolate the contribution to overall military-unit mission effectiveness of organizations, processes, people, digital networking technology, armor, or external factors. Nevertheless, our analysis indicates that NCO capabilities made an important contribution at the tactical level to mission performance in many areas. When we “integrate,” or add the results of these discrete individual tactical operations together, we find that NCO capabilities can contribute to a significant improvement to the mission effectiveness of military units in the security-mission component of stability operations (Figure S.7).

The importance of NCO capabilities in the stability operations of the 1/25 SBCT was also noted by Kaplan:

New hardware . . . plays a big role, facilitating a change in the relationships between captains in the field and majors and lieutenant colonels back at battalion headquarters. . . . a computer system that gives captains and noncommissioned officers situational awareness and the latest intelligence for many miles around—has helped liberate field units from dependence on headquarters.

Autonomy is further encouraged by the flat “intelligence architecture” of the Stryker brigades. Information now comes to captains less and less from battalion headquarters, and more and more from other junior officers in other battalions, via informal e-mail networks, as well as directly from Iraqi units. The lieutenant colonel who commands an infantry battalion, and the major who is the captain’s

Figure S.7
Adaptation of Materiel and Nonmateriel NCO Force Elements

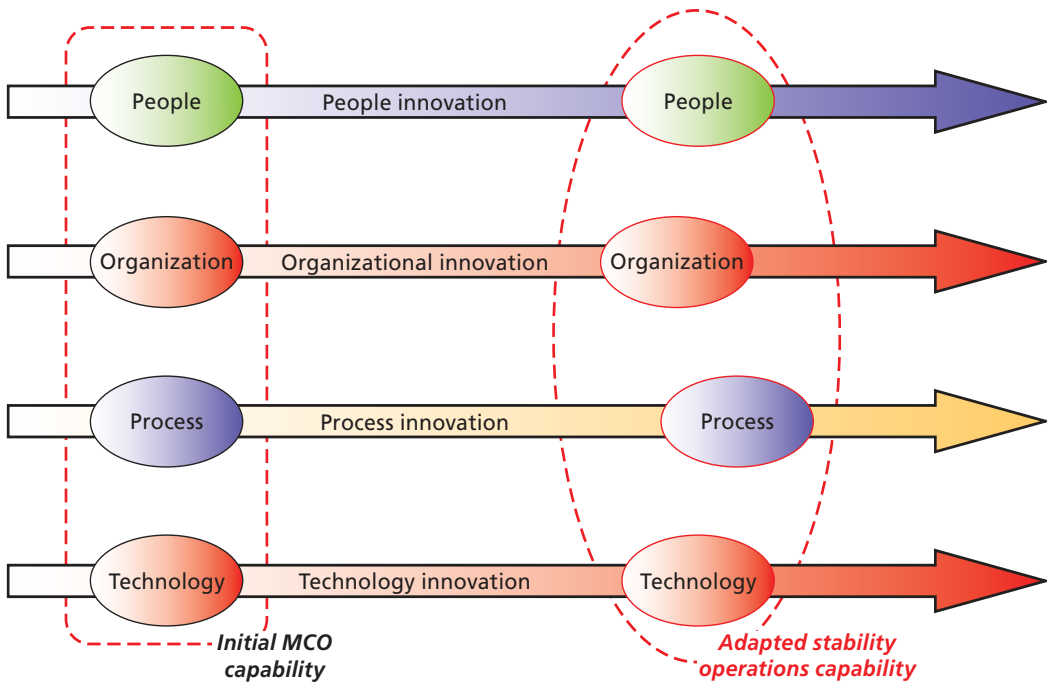

RAND MG593-S.7

executive officer, do not always have to be consulted. Given the results, the commanding officers like it that way.⁸

Kaplan is describing classic findings in the NCO literature—the ability of networked forces to become more responsive, more adaptive, and able to make effective command decisions at lower levels without waiting for intelligence and other information to flow up to higher headquarters and down again.⁹ Earlier, we used terminology

⁸ Kaplan, 2006.

⁹ See, for example, David S. Alberts et al., *Understanding Information Age Warfare*, Washington D.C.: CCRP Publication Series, August 2001; and David S. Alberts and Richard E. Hayes, *Power to the Edge: Command and Control in the Information Age*, Washington, D.C.: CCRP Publications Series, 2003. Earlier discussions of flattened decision, production, and supply chain networks can also be found in the reengineering business literature.

borrowed from the NCO literature to describe the same advantages of NCO systems noted by Kaplan—small-unit self-synchronization, swarming, and adaptive command and control.

Summary of Network and Intelligence Capabilities

A summary of the 101st ABD, 3/2 SBCT, and 1/25 SBCT networks is shown in Table S.2. There were significant differences among all three networks. The 1/25 SBCT’s

Table S.2
Summary of SBCT Networking and Battle Command Enhancements

	101st ABD	3/2 SBCT	1/25 SBCT
FBCB2/BFT on AVN	40 AH-64 30 UH-60 12 CH-47 82 total	On helicopters supporting 3/2	On helicopters supporting 1/25
FBCB2/BFT per infantry brigade on C2 vehicles	5–8	13	13
FBCB2/EPLRS on ground vehicles			
Stryker vehicles	0	317	317
Other vehicles	0	~280	~280
Reliance on MSE/NTDR for brigade–battalion communications	Yes	No	No
IKSS SATCOM terminals	0	10	10
TeamSpeak/SIPRNET for brigade battle update brief	No	No	Yes 50–80 participants
Access to Rover III communications terminals	No	No	Yes Batallion level
Fiber-optic links	No	No	Yes Brigade TOC– battalion TOC– company TOC
PDA’s or “CSI Mosul” information	0	0	Some infantry soldiers

 Factor with a relative disadvantage  Factor with a relative advantage

network was considerably more capable, especially from a joint operations perspective.¹⁰

Intelligence Capabilities

Intelligence challenges associated with the Iraqi insurgent and terrorist forces required most Army units to employ new intelligence analysis approaches and new tools to analyze the composition of insurgent groups. Many of the intelligence capabilities of the 101st ABD and the 3/2 SBCT were very similar. They both used standard Microsoft Office products to do much of this analysis because Army MCO-focused intelligence tools were less useful for stability operations.

The 1/25 SBCT had additional intelligence capabilities the other two units did not possess, including software tools from the law enforcement community that were adapted to analyzing insurgent networks. The 1/25 SBCT was also able to make effective use of joint and national ISR capabilities to a much greater extent than a traditional light infantry brigade could. The integration of these ISR sources was made possible by having appropriately trained and cleared personnel at the brigade level and by new system capabilities.¹¹ While these joint and national ISR sources were not new, their effective integration into tactical operations in real time was. The ability to use the information they generated in real time, using networks, led to significant operational performance improvements, as described in the classified addendum to this monograph. The additional intelligence capabilities of the 1/25 SBCT, along with its NCO capabilities, enabled it to effectively exploit precise but perishable actionable intelligence.

Caveats

As noted earlier, Stryker brigades are equipped with medium-weight armored vehicles, while the 101st ABD is equipped with predominantly soft-skinned vehicles. However, only about half the SBCT vehicles are Stryker vehicles. The other half are HMMWVs like those used in light infantry units. Up-armored HMMWVs were distributed to the

¹⁰ SBCT units are supported by UH-60 and OH-58 Kiowa Warrior helicopters (see Tonya K. Townsell, "Enhancements in Store for Future Stryker brigades," *Army Communicator*, Winter 2003). The number of helicopters assigned to the SBCTs (and thus the number of FBCB2-BFT systems on avionics platforms) varied, although this number was always far less than the number in the 101st ABD. For example, the 3/2 SBCT initially had only four UH-60 helicopters supporting it; the number increased by ten by the end of the unit's deployment. The 3/2 SBCT was also supported with 24 OH-58D Kiowa Warrior reconnaissance helicopters by the end of the deployment (Rounds, 2004).

¹¹ A description of these ISR integration capabilities is included in the classified annexes to this report.

3/2 and 1/25 SBCTs but were not available to the 101st ABD in 2003. While this armor protection provided a force protection advantage for the SBCTs relative to the 101st ABD, it should be noted that many Stryker engagements were fought dismounted (for example, raids against high-value targets). Furthermore, insurgents frequently targeted armored vehicles in improvised explosive device (IED) attacks and designed IEDs to maximize their effectiveness against armored vehicles. Insurgents also targeted logistics convoys, many of which are composed of trucks and HMMWVs. To counter the IED threat, U.S. forces deployed to Iraq in 2004 and later (including the 3/2 and 1/25 SBCTs but not the 101st ABD) were equipped with electronic counter measures such as Warlock and the IED Countermeasures Equipment (ICE) system. These systems have contributed to increased force protection capability in mounted and dismounted operations throughout Iraq. For these reasons, the difference in casualty rates between the two SBCT units and the 101st ABD is probably due to multiple factors. However, it is interesting to note that casualty rates for the 3/2 and 1/25 SBCTs are significantly less than other U.S. units that operated in Iraq during the same time periods, when up-armored HMMWVs, Warlock, and ICE systems were available to many if not all U.S. units (see Figure S.2).

We recognize armor is an important factor contributing to the mission effectiveness of the Stryker brigade. However, many factors contribute to Stryker brigade effectiveness, such as the Stryker vehicle's mobility and its NCO capabilities. The mobility of the Stryker vehicle gives the SBCT the speed and agility to rapidly respond to changes in the battlespace that are represented in the common operational picture provided through the network. The Stryker vehicle also delivers more firepower than light infantry units typically have, but it is not clear that this firepower was a dominant or even an important factor in many stability operations. We do know the vehicle is used effectively as protection against enemy fire. In this study, it was not possible to isolate the contributions of individual attributes (either armor or the capabilities of the Stryker information network) to the observed increase in force effectiveness and force protection.

Additional Findings

We did note two specific challenges and shortcomings:

Ninawah province and its 2.5 million residents appear to be too large to be covered by a single brigade. More "boots on the ground" were needed. The 3/2 and 1/25 SBCTs

were unable to effectively conduct stability operations in Ninawah province without assistance from other units.

It is exceedingly difficult for a military unit to conduct stability operations in one area while being tasked to frequently conduct out-of-area operations. A continuous force presence in Mosul and Tal Afar were difficult to sustain by the 3/2 SBCT because of extensive out-of-area operations. Social networking with local populace and leaders is degraded when commanders and soldiers are not able to “settle down” in a particular neighborhood or town and get to know the local politics and cultural background.

Army Battle Command Systems and Stability Operations

All units encountered significant challenges in using the Army Battle Command Systems (ABCS) at command centers for situation awareness of the enemy and the local population. Traditional “red icons” depicting the location and capabilities of enemy units did not match well to tracking the activities of insurgents. Similarly, ABCS lacked forms or displays suited for tracking developments with the local population (demonstrations, results of personal contacts, etc.). As a result, much information was transmitted using text messaging and text chat, which could not automatically populate databases and situation awareness screens. Some ABCS, notably ASAS and the Maneuver Control System–Heavy, were considered to be unsuitable for stability operations and were largely not used. The use of FBCB2 text messaging, while useful at the tactical level, could also sometimes result in key messages about engagements not being reviewed by personnel at the brigade tactical operations center.

Language and Culture

SBCT soldiers frequently requested additional linguists (linguists who both spoke and wrote Arabic fluently and could be fully trusted were in short supply), even to provide simple open-source intelligence functions such as reading Iraqi media. There were also requests for more language and cultural training.

Recommendations

We recommend several net-centric capability improvements.

BFT and Battle Command Systems

- *Field FBCB2, or FBCB2-compatible systems, on a wide scale at the tactical level.* The FBCB2 system was a key enabler of the improved situation awareness, speed of command, and synchronization of SBCT units. The system is deployed widely enough in Stryker units to make it a key capability for SBCT tactical units, as opposed to being merely a tool for senior commanders. We recommend that FBCB2, or FBCB2-compatible systems, be widely deployed at the tactical level throughout Army and Marine Corps units, as well as to key coalition partners such as the United Kingdom and Australia.
- *Add classes or message address lists to FBCB2, and ensure that messaging a class is the standard when reporting engagements.* This subject is discussed in the classified annexes to this document.
- *Expand FBCB2's preformatted reports to include more stability operations–related reports and make them easier to use.* Add report templates for demonstrations, suspicious activities, relations between suspects, patrol debriefs, and results of informal and formal meetings.
- *Provide battle command devices or at least BFT devices to dismounted units.* SBCT soldiers requested the auto-population of dismount locations on FBCB2, at least down to the team level.

Red Force and Cultural Awareness

- *Provide a common suite of analysis tools for performing pattern, link, and temporal analyses of tactical stability operations.*
- *Relax procedures for disseminating HUMINT to provide actionable information to those soldiers needing it.*
- *Provide additional training.* Soldiers requested additional training on the processing of material collected from operations, tactical questioning, and general cultural awareness. They also requested training on civil affairs, languages, information operations, negotiation, and HUMINT.

Acknowledgments

We thank several people who made this research project and report possible: John Garstka, of the Office of Force Transformation, for his thoughtful oversight of this research; Admiral Arthur Cebrowski, the original director of OFT, for sharing his insights with us during his review of this research when it was in its formative stages; Mr. Terry Pudis in his capacity as the deputy director of OFT and later as the acting director of OFT, for his constructive criticism and review of this research; COL Gary Agron, who helped formulate and start this research project; COL Robert Ballew, for his expert advice and help in tracking down information on Army helicopter units; COL Robert B. Brown, former commander, 1st Brigade, 25th Infantry Division (SBCT), for sharing his insights, experiences, and views on many subjects examined in this report; COL Joseph Anderson, former commander, 2nd BCT, 101st Airborne Division, for sharing useful information with us in addition to providing feedback on our initial results and findings; COL Stephen J. Townsend, Commander, 3/2 SBCT, for sharing his insights, experiences, and views; MAJ Anthony L. Benitez, of the U.S. Army Infantry School, for enabling us to participate in the Infantry School Stryker brigade lessons-learned workshops and conferences; Fred Stein of Mitre, for sharing his insights and primary-source documentation on Stryker brigade operations in Iraq; Gary Reid, Director, Special Operations Policy, Office of the Deputy Assistant Secretary of Defense for Special Operations Capabilities, for sharing his knowledge on operations in Mogadishu, Somalia, in October 1993; and finally, the soldiers from the 101st ABD and 3/2 and 1/25 SBCTs who completed our survey upon their return from Iraq.

The report was reviewed by our RAND colleagues Walt Perry and Jim Quinlivan. We thank them for the considerable time and effort they devoted to this task.

Abbreviations

AAR	after action report
ABCS	Army Battle Command Systems
ABD	airborne division
ACE	all-source collection element
ACR	armored cavalry regiment
AHRF	ad hoc response force
AIF	anti-Iraqi forces
AO	area of operations
AOR	area of responsibility
AMRT	alternate master reference terminal
APV	armored personnel vehicle
ASAS	All Source Analysis System
AVN	aviation
AWTs	air weapon teams
BATS	Biometric Automated Tool Set
BDE	brigade
BFSA	blue force situation awareness
BFT	Blue Force Tracking
BIAP	Baghdad International Airport
BLOS	beyond line of sight
BN	battalion
BSB	brigade support battalion
BSN	brigade support node
C2	command and control

C2/BC	command and control/battle command
CAS	close air support
CAV	cavalry
CENTCOM	U.S. Central Command
CERP	Commander's Emergency Response Program
CONUS	continental United States
COP	common operational picture
COTS	commercial off-the-shelf
CPA	Coalition Provisional Authority
CSAR	combat search and rescue
CSC	combat support company
CSI	crime scene investigation
DB	database
DIV	division
DoD	Department of Defense
DoDD	Department of Defense Directive
DOTMLPF	doctrine, organization, training, materiel, leadership, personnel, and facilities
DSCS	Defense Satellite Communications System
EPLRS	Enhanced Position Location Reporting System
FBCB2	Force XXI Battle Command Brigade and Below
FM	frequency modulation
FOB	forward operating base
FRAGOs	fragmentary orders
FSB	forward support brigade
FWD	forward
GDP	gross domestic product
GPS	Global Positioning System
GRF	ground reaction force
HA	humanitarian assistance
HCLOS	high capacity line of sight
HUMINT	human intelligence
HMMWV	high mobility multipurpose wheeled vehicle
ICE	IED Countermeasures Equipment

IECI	Independent Electoral Commission of Iraq
IED	improvised explosive device
IKSS	Interim Ku-band Satellite System
ING	Iraqi National Guard
IP	internet protocol
ISF	Iraqi security forces
ISR	intelligence, surveillance, and reconnaissance
JDAM	Joint Direct Attack Munition
JFACC	joint force air component commander
JOC	joint operations center
JRTC	Joint Readiness Training Center
JTAC	joint terminal attack controller
Kbs	kilobytes
KIA	killed in action
LANTIRN	Low Altitude Navigation and Targeting Infrared for Night
LOS	line of sight
MCO	major combat operations
MCP	mission capabilities package
MCS-L	Maneuver Control System–Light
MDR	medium data rate
MI	military intelligence
MIRC	Multi-User Internet Relay Chat
MNC-I	Multi-National Corps–Iraq
MNF-I	Multi-National Forces–Iraq
MOE	measure of effectiveness
MOP	measure of performance
MP	military police
MSE	mobile subscriber equipment
NAIs	names areas of interest
NCO	network-centric operations
NCO CF	NCO Conceptual Framework
NTDR	near-term digital radio
OASD(NII)	Office of the Assistant Secretary of Defense for Networks and Information Integration

OIF	Operation Iraqi Freedom
OPTEMPO	operational tempo
PDA	personal digital assistant
QoI	quality of information
QRF	quick response force
RPG	rocket-propelled grenade
RSTA	reconnaissance, surveillance, and target acquisition
RVT	remote visual terminal
S2	Army intelligence officer
SA	situation awareness
SATCOM	satellite communications
SBCT	Stryker brigade combat team
SIG	signals
SIGACT	significant actions
SIGINT	signals intelligence
SINGCARS	Single-Channel Ground and Airborne Radio System
SIPRNET	Secret Internet Protocol Router Network
SMART-T	Secure Mobile Anti-Jam Reliable Tactical-Terminal
SOF	special operations forces
SOP	standard operating procedure
SSTR	stability, security, transition, and reconstruction
SVBIED	suicide vehicle-borne improvised explosive device
TACSAT	tactical satellite
TCP	traffic control points
TDMA	time division multiple access
TF	task force
TOC	tactical operations center
TOW	tube-launched, optically-tracked, wire-guided
TROJAN SPIRIT	TROJAN Special Purpose Integrated Remote Intelligence Terminal
TTPs	tactics, techniques, and procedures
UAV	unmanned aerial vehicles
UHF	ultra-high frequency
UN	United Nations

USAF	United States Air Force
USMC	United States Marine Corps
VIED	vehicular improvised explosive device
WIA	wounded in action

Introduction

Background

The Stryker Brigade Combat Team (SBCT), one of the newest units in the U.S. Army, employs advanced communications and command and control (C2) capabilities and uses an information-centric concept of operations with elements that are very similar to concepts found in the Network Centric Operations Conceptual Framework (NCO CF) developed by the Office of Force Transformation and Office of the Assistant Secretary of Defense for Networks and Information Integration OASD(NII).¹

The elements of the SBCT have been developed, integrated, and evolved as a mission capabilities package, which includes capabilities (materiel and non-materiel) and the doctrine, organization, training, materiel, leadership, personnel, and facilities (DOTMLPF) necessary to employ these capabilities effectively.² In NCO terms, the development of SBCT capabilities is based not only on injecting new technology into this unit but also on simultaneously developing the nonmateriel DOTMLPF capabilities necessary to gain the maximum benefit from new networking and C2 systems.

¹ The current version of the NCO CF is Version 2.0 (Department of Defense, Office of Force Transformation, *Network Centric Operations Conceptual Framework*, Version 2.0, August 20, 2004); the NCO CF is also described in David A. Signori, "A Conceptual Framework for Network Centric Warfare," presented at the Technical Cooperation Program's Network Centric Warfare Network Enabled Capabilities Workshop, Virginia, December 17, 2002; Major concepts of NCO are described in David S. Alberts, John J. Garstka, and Frederick P. Stein, *Network Centric Warfare: Developing and Leveraging Information Superiority*, Second Edition (Revised), Washington, D.C.: CCRP Publications Series, 1999; and David S. Alberts and John J. Garstka, *Network Centric Warfare*, Department of Defense Report to Congress, July 27, 2001.

² In this monograph, we use the term *mission capabilities package* as it has been defined in David S. Alberts, *Mission Capability Packages*, Strategic Forum, Institute for National Strategic Studies, No. 14, January 1995; and Alberts and Hayes, 2003.

The SBCT combines sensors, decisionmakers, and shooters in a single network. It achieves shared awareness and understanding—and ultimately increases combat effectiveness—through increased speed of command, higher tempo of operations, greater lethality, increased survivability, and a greater degree of self-synchronization.³ To do this, the SBCT adds a number of new materiel and nonmateriel capabilities, including the following:

- The information-centric concept of operations, centered on making decisions and rapidly adapting operations using incoming information.
- Improved networking capabilities, including widespread deployment of a blue force situation awareness and communications system, Force XXI Battle Command Brigade and Below (FBCB2),⁴ deployment of an interim satellite communications (SATCOM) mobile network, and deployment of the evolving Army Battle Command Systems (ABCS).⁵
- A dedicated reconnaissance, surveillance, and target acquisition (RSTA) squadron and a dedicated military intelligence (MI) company. These two units significantly increase the SBCT's organic intelligence, surveillance, and reconnaissance (ISR) capabilities and ability to fuse sensor data and reports quickly to generate high-quality situation awareness of the enemy.
- A new family of Stryker vehicles featuring speed and stealth characteristics.

As an example of how the SBCT combines capabilities and DOTMLPF, the SBCT is equipped with the full complement of current-generation Army digital terrestrial and satellite communications and the current generation of Army battle command systems. The SBCT organizational structure was designed to leverage these new digital systems. Both are central to the brigade's ability to generate, share, and act rapidly on situation awareness information. The methods of employment of SBCT communications and battle command systems have been tailored to get the most out

³ *Self-synchronization* refers to the ability of a well-informed force to organize and synchronize complex activities from the bottom up. The key is in the last phrase, "bottom up." In the past, such organization and synchronization had to come from the top down, e.g., from division headquarters. See Vice Admiral Arthur K. Cebrowski and John J. Garstka, "Network Centric Warfare: Its Origin and Future," *U.S. Naval Institute Proceedings*, January 1998.

⁴ FBCB2 is a battle command information system for brigade level and below. It is one component of ABCS.

⁵ ABCS is the Army's component of the Global Command and Control System. It is a system of systems that transmits information among the elements of the Joint Force.

of these systems and are based on new Army doctrine that emphasizes the importance of information in combat operations.

Objectives

The objective of this study is to understand whether SBCT NCO capabilities provide an information advantage and, if so, whether that advantage translates into increased mission effectiveness in conducting stability operations.

In our previous case study (*Network-Centric Operations Case Study: The Stryker Brigade Combat Team*), we found that such capabilities did provide significant information advantages and increase force effectiveness in missions related to major combat operations (MCOs). We found that the SBCT used a combination of advanced doctrine and tactics, techniques, and procedures (TTPs) to exploit improved networking and ISR capabilities, which led to better combat performance. In particular, during the 3/2 SBCT's certification exercise at the Joint Readiness Training Center (JRTC), the brigade achieved a force-loss exchange ratio ten times greater than the standard performance for a light infantry brigade.

This study seeks to determine whether the SBCTs were able to use advanced doctrine and TTPs to exploit NCO capabilities and thus achieve improved combat performance for stability operations in Iraq (Operation Iraqi Freedom [OIF], Phase II) as well.

Before delving into the analytic approach of the study, it is important to first address the definition of stability operations as well as the scope of this monograph. *Stability operations* as used in this monograph are defined according to the Department of Defense Directive (DoDD) 3000.05 as “military and civilian activities conducted across the spectrum from peace to conflict to establish or maintain order in States and regions.”⁶ This monograph also considers the role of the military in operations to support stability, security, transition, and reconstruction (SSTR), which is also specifically defined in this directive.

The scope of the monograph is based on specific DoD policy outlined for stability operations in DoDD 3000.05. DoD policy includes the goal to “provide the local

⁶ Department of Defense Directive (DoDD) 3000.05, *Military Support for Stability, Security, Transition, and Reconstruction (SSTR) Operations*, Washington, D.C., November 28, 2005, p. 2.

populace with security, restore essential services, and meet humanitarian needs.”⁷ We evaluate the first of these three goals, providing security to the local populace. In addition, we evaluate the performance of the U.S. military—specifically, the three units mentioned below—in establishing or maintaining order, rebuilding security forces, and developing representative governmental institutions. However, we do not address the rebuilding of correctional facilities, judicial systems, or the revitalization of the private sector because we lack sufficient data on the units’ performance in these areas.

Analytic Approach

This research employs a case study methodology to examine three units that operated in the same area in Iraq. The 101st Airborne Division (ABD) represents the first case; the other two cases are two SBCTs (3/2 and 1/25) that followed the 101st ABD sequentially in the same area. The 101st ABD was in Iraq from the spring of 2003 until January 2004. The 3/2 SBCT operated in the same provinces as did the 101st ABD from January 2004 until October 2004, and the 1/25 SBCT, which had its area of responsibility narrowed, operated in two of the same provinces as did the 101st ABD from October 2004 until October 2005.

We recognize the issues inherent in the case study methodology and in the specific comparisons we make in this study. Case studies are essentially qualitative comparisons, although they can be informed by quantitative information. Additionally, they are analogies because the cases are not identical. We also recognize that the situations confronting the three units differed. Even though all three were in approximately the same area of Iraq, the situations the units faced differed substantially over time. The 101st ABD was there shortly after major combat operations concluded but before the insurgency had become intense. The two Stryker brigades did not have identical sets of equipment, with the 1/25 SBCT having an enhanced suite of communications equipment compared with the 3/2 SBCT. That said, we believe that the methodology can shed light on the performance of the two types of units and on how NCO capabilities affect unit performance.

Several reasons motivated our choice of comparisons. First, we wanted to compare the Stryker brigade, with its digital networking and other NCO capabilities, to an analog-equipped unit that was tasked to perform similar stability operations. U.S.

⁷ DoDD 3000.05, p. 2.

forces have conducted stability missions around the world over the past decade, and many of the Army forces in these past operations were analog-equipped units. However, the stability operations conducted in the past few decades took place in different parts of the world with much different geography, cultures, and populations than Iraq. Furthermore, the character of the insurgency and the forces in Iraq differs substantially from the character of the stability operations and adversaries confronted in earlier missions in Kosovo, Serbia, or even in Afghanistan. For these reasons, we determined it was best to compare the performance of Stryker brigades in Iraq with other units that performed stability operations in the same country. After this decision was made, the 101st ABD became a natural choice for comparison with the Stryker brigades because all these units had been at one time responsible for approximately the same region in Iraq. As described in detail below, initially the 3/2 SBCT was given responsibility for the large area the 101st ABD was previously responsible for. In other words, in an economy-of-force role, the 3/2 SBCT became responsible for a very large division-sized area. The 1/25 SBCT also operated in the same area, although it had reduced geographic responsibilities.

Furthermore, although all three units were augmented with additional capabilities just before their deployment to Iraq, the 101st ABD in its first OIF rotation was still predominantly an “analog” unit that relied primarily on analog combat net radios for voice-only communications at the tactical level. Note that while some ground unit commanders in the 101st ABD had the Blue Force Tracking (BFT)⁸ satellite-based system and most command centers possessed the ABCS suite, the bulk of 101st ABD soldiers did not have FBCB2 or the other advanced digital networking capabilities of the Stryker brigades. Thus, by comparing these units, we should be able to determine what effects were due to the significant differences in the networking capabilities of the analog and digital units.

In summary, there are a number of reasons why we believe the 101st ABD is the best baseline for comparison to the Stryker brigade in conducting stability operations:

- The 101st ABD had the same northern Iraq area of responsibility (AOR) immediately before the 3/2 SBCT, allowing for direct operational comparisons.

⁸ BFT is a satellite-based system that enables ground commanders to track friendly unit locations in near real time. Transmitters in friendly vehicles relay a signal through satellites that displays on screens in other vehicles and command centers.

- The SBCT was originally designed to at times replace light infantry brigades in rapid deployment missions where greater mobility and firepower are necessary, and we believe it is valuable to compare the SBCT with units it might replace in certain operations. The majority of the 101st ABD's brigades are light infantry brigades.
- We wanted to understand the role and possible advantages NCO capabilities may have in ground warfare. Thus, it is desirable to compare the SBCT to a nondigitized unit. Recall that the 101st ABD, in its first OIF rotation, was not a digitized unit.

NCO Conceptual Framework

Figure 1.1 graphically presents the NCO conceptual framework. This figure also illustrates the operational concept for the SBCT in the form of a flowchart, showing how improvements in the unit's ISR and networking capabilities ("Robustly networked force") are expected to lead to eventual improvements in mission effectiveness.⁹ The

Figure 1.1
NCO Conceptual Framework

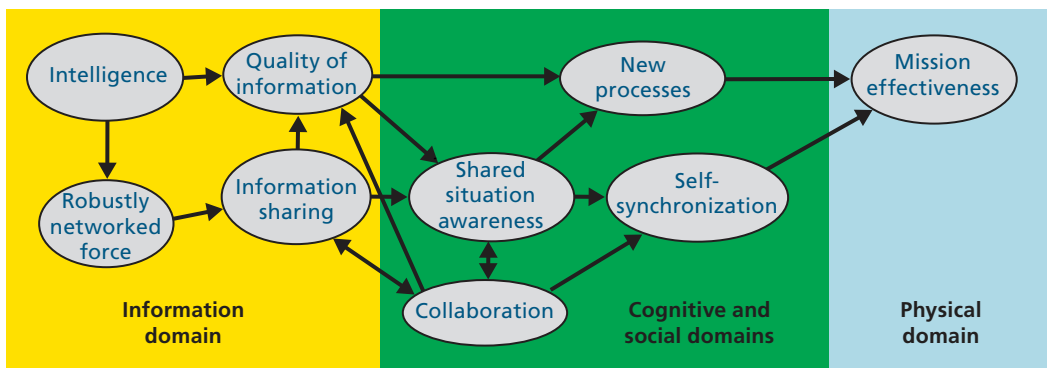

RAND MG593-1.1

⁹ Army SBCT doctrine is articulated in different terms; however, as previous analysis reveals, the Stryker operational concept is very nearly identical to the NCO Conceptual Framework (Daniel Gonzales et al., *Network-Centric Operations Case Study: The Stryker Brigade Combat Team*, Santa Monica, Calif.: RAND, MG-267-1-OSD, 2005).

concepts shown in the graph have been defined in OASD(NII)'s *Network Centric Operations Conceptual Framework*. The figure shows input/output links, feedback loops, and potential multiplicative influences among the NCO concepts.

The logic of the NCO CF and the SBCT operational concept is as follows:

- The SCBT's ISR and networking enhancements improve the sharing and quality of information and thus create a shared "common picture" of battlespace information.
- The common picture enables new processes, enhances shared situation awareness, and supports collaboration (which, in turn, helps refine the common picture, creating a positive reinforcement cycle).
- The combination of improved shared situation awareness and collaboration leads to improved self-synchronization. Improved self-synchronization, combined with new processes, leads to greater mission effectiveness.

Later in this monograph, we look for evidence that the logic of the framework and operational concept operates as intended when we evaluate the SBCT's performance in stability operations and compare its performance with that of a baseline unit.

Analysis Methodology

Our approach leverages the NCO logic described above but also takes into account some of the key differences among the three units we assess, and important background or external factors that can influence unit performance and mission effectiveness. The major elements of the monograph's analytical approach are illustrated in Figure 1.2.

The first element involves understanding the operational context for the military units under consideration. This includes understanding both the post-MCO environment in Iraq, including the strength, motivations, and tactics of the adversary (the major insurgent groups operating in northern Iraq at particular times) and the number and types of operations and engagements the U.S. units participated in during their deployment. We group these as external factors in Figure 1.2. The second element includes developing accurate descriptions of the organization of each U.S. military unit, the resources they had for stability operations and reconstruction, and the other factors listed in Figure 1.2 under organization. Chapter Two describes the post-MCO operational environment and other external factors and also describes the organization of each U.S. military unit considered in the assessment. Additional key elements of

Figure 1.2
NCO Analysis Approach

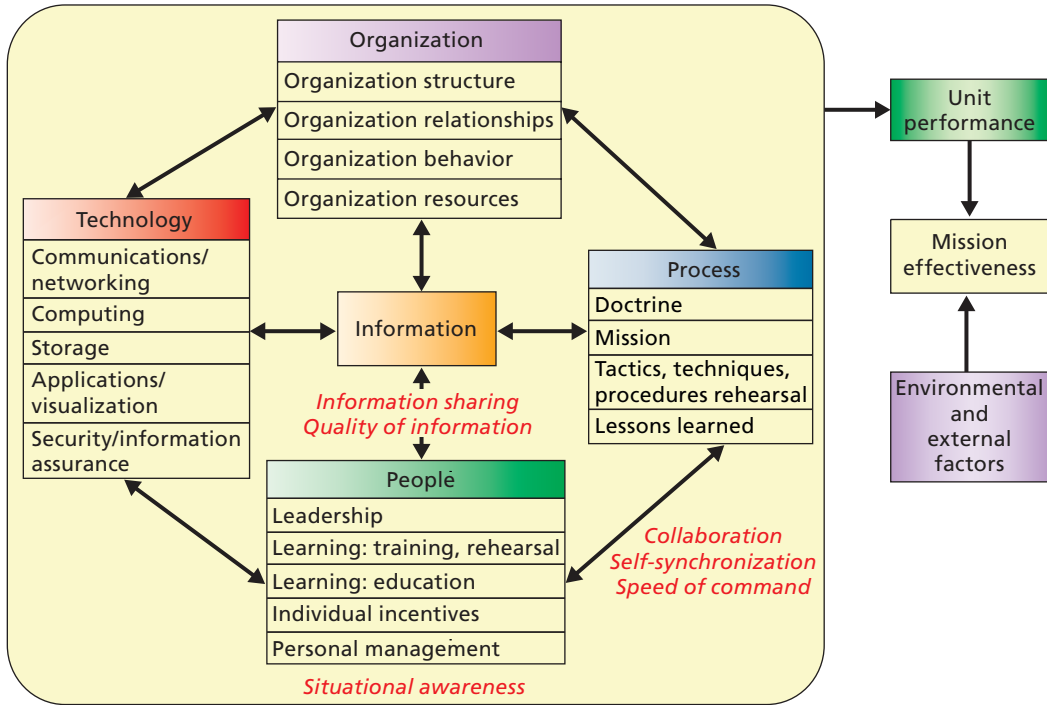

RAND MG593-1.2

analysis are the networking and battle command or command and control capabilities of the SBCTs and the 101st ABD.

We also analyze the degree of networking, which captures the ability of each unit's network to share three types of information in a correct and timely manner: blue force information, information on engagements and immediate threats, and red force and local population (cultural) information. Given the importance and complexity of red force and cultural information, we examine in detail the network's ability to collect, process, analyze, share, present, and visualize this information. In the classified annexes to this report, we used a four-point rating scheme (green, amber, red, black) as a subjective assessment of the performance of the SBCTs' network links in sharing each type of information. More important, we discuss the lessons-learned data lead-

ing to the assessment, pointing out specific performance achievements and shortfalls reported by the SBCT soldiers. Details of this analysis are presented in the classified annexes and are briefly summarized in Chapter Three.

In addition, we assess the quality of shared information and interactions in the SBCTs and the 101st ABD. We use the results of our surveys of SBCT and 101st ABD leaders to measure these attributes, paying particular attention to significant differences between the SBCT and 101st ABD leaders. We assess the quality of shared information and interactions in four areas: cordon-and-search/knock-and-raid operations, convoy operations, humanitarian assistance/infrastructure reconstruction operations, and collaboration in general. This analysis is included in Chapter Three and the conclusions.

Still another key element of analysis consists of the processes that units employ to execute stability operations, including whether a particular unit does or does not employ certain tactics or missions that may be counterproductive in stability or counterinsurgency operations. We examine the performance of the three units in actual tactical operations in Iraq. Where appropriate, we compare their performance to that of other units elsewhere to discern whether and how networking and C2 capabilities affected mission performance. Some of this mission analysis is classified and is discussed in the classified addendum to this report. This analysis is included in Chapter Four.

The last element of the analysis process is to examine the impact of external factors and the cumulative effect of unit performance in the many engagements and tactical missions executed over the unit's entire rotation and to make a judgment on whether that unit contributed positively or negatively toward the accomplishment of the long-term or strategic implications of the presence of U.S. forces in Iraq. These issues are considered in Chapter Five.

Sources of Information

We drew on three primary sources of information for this study: lessons learned, conferences, and a survey administered to key members of the three units. First we collected lessons-learned data for multiple SBCTs and for the 101st ABD that review their post-MCO operations in Iraq. These lessons-learned documents and data concentrate on lessons learned relating to the performance of cordon/search/raid operations, convoy operations, and humanitarian-assistance and infrastructure-reconstruction operations.

Lessons-learned documents reviewed include *Initial Impressions Report—Operations in Samarra, Iraq*,¹⁰ *Initial Impressions Report—Operations in Mosul, Iraq*,¹¹ and *101st ABD Lessons Learned*.¹² The study team reviewed the 3/2 SBCT's classified after-action report, materials provided by the Stryker Center for Lessons Learned at Fort Lewis, Washington, materials obtained from Multi-National Forces–Iraq (MNF-I) headquarters, and information from Central Command (CENTCOM) headquarters.

For conferences, the study team attended the Army Training Center SBCT's Iraq lessons-learned conference, held in January of 2005. The team also attended the Army Infantry School's Stryker lessons-learned conference, which sought to disseminate lessons from the January conference to the entire SBCT community. The latter conference provided feedback from 3/2 SBCT commanders on the effectiveness of FBCB2 and stability-operations campaign objectives.

The study team's survey of 3/2 SBCT and 101st ABD leaders garnered 15 responses from 3/2 SBCT leaders and 14 responses from 101st ABD leaders. The team also interviewed some of the officers, including COL Joseph Anderson, commander of the 2nd Brigade, 101st Airborne Division, COL Robert Brown, commander of the 1st Brigade, 25th Infantry Division SBCT, during OIF, and COL Steve Townsend, commander of the 3rd Brigade, 2nd Infantry Division SBCT. In addition, the study team interviewed 3/2 SBCT and 1/25 SBCT Stryker brigade soldiers of all ranks. Finally, the study team also observed the 1/25 SBCT during an exercise at the JRTC.

Organization of Monograph

This monograph is organized in the following manner. Chapter Two discusses the Iraqi operational environment, the organization of the units we examine, their area of operations (AO), and the resources they were given for humanitarian assistance and reconstruction. Chapter Three focuses on networking and C2 systems for the 101st ABD, 3/2 SBCT, and the 1/25 SBCT. Chapter Four analyzes NCO system performance.

¹⁰ Center for Army Lessons Learned, *Operations in Samarra, Iraq*, Stryker Brigade Combat Team 1, 3rd Brigade, 2nd Infantry, Initial Impressions Report No. 05-7, December 2004, not releasable to the general public.

¹¹ Center for Army Lessons Learned, *OPERATIONS IN MOSUL, IRAQ IIR*, Updated Final Draft, 1st Brigade, 25th ID SBCT, March 15, 2005, not releasable to the general public.

¹² U.S. Army, *Operation Iraqi Freedom Lessons Learned*, 101st Airborne Division (Air Assault), May 23, 2003, not releasable to the general public.

It considers how information is collected, processed, and analyzed and the quality of information and collaboration for cordon-and-search and convoy operations. Chapter Five discusses mission effectiveness in tactical stability operations and assesses cumulative effects of each unit's performance over its entire rotation. Chapter Six closes with findings and observations as well as challenges and shortcomings identified in this study. The report also has several appendixes. Appendix A is a copy of the memorandum approving the study. Appendix B discusses the TTPs used by the Stryker brigades in OIF. Appendix C looks at adaptive decisionmaking and synchronization in stability operations. Finally, Appendix D provides greater background on the Iraqi national elections in 2005.

Iraqi Operational Setting and Unit Characteristics

This chapter discusses the operational environment U.S. forces faced in Iraq. This environment has proven to be more complex and difficult than originally envisioned before the start of OIF. The situation is made more complex by the fact that not all regions of Iraq have the same ethnic composition or political dynamics. We first describe the overall environment in Iraq and the ethnic tensions among segments of the Iraqi population that came to the surface after the downfall of the Saddam Hussein regime. Next we focus on the operational environment in northern Iraq, which is where the three units we examine in this study—the 101st ABD, 3/2 SBCT, and 1/25 SBCT—conducted stability operations. This operational environment changed during the tenure of these three units in Iraq; we describe those changes below.

During the operations of the three units, U.S. forces faced a combination of indigenous insurgent and foreign terrorist forces, adversaries that adapted to U.S. and coalition actions over time. In spite of enemy actions, U.S. forces were called on to stabilize the situation, help restore essential services to the population, and support reconstituted local and regional government institutions. In addition, U.S. forces were tasked to train large numbers of Iraqis to form new military units of the Iraqi National Guard (ING), a task that became all the more important following the decision to disband the former Iraqi national army.

The Iraqi insurgency is prevalent predominantly in an area we term the larger “Sunni Triangle.” Figure 2.1 highlights this area and shows the distribution of different ethnic groups throughout Iraq. This map indicates that the larger Sunni triangle includes those areas marked “Sunni Arab,” “Sunni Arab/Kurd mix,” and “Shia/Sunni Arab mix.”

Figure 2.1
The “Sunni Triangle” and U.S. Unit Operating Areas

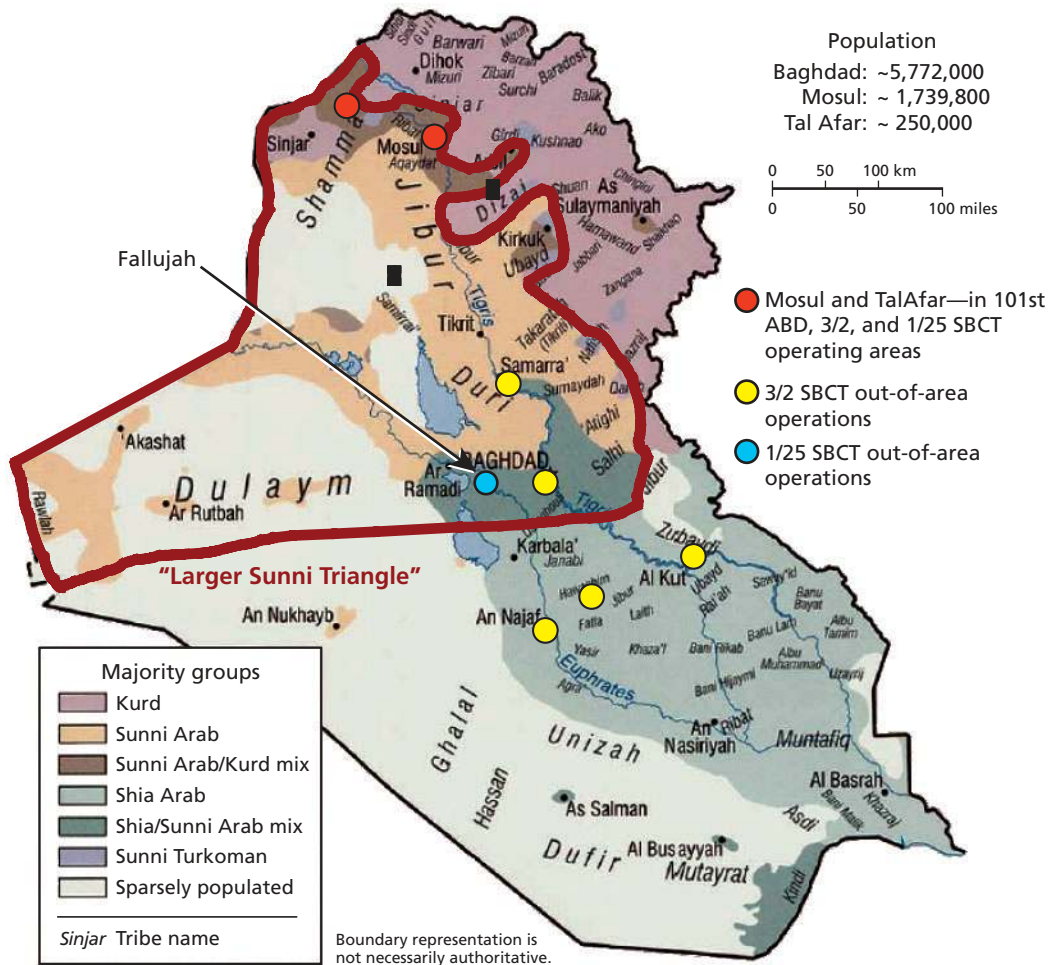

NOTE: Defined according to the demographics of Iraq.

RAND MG593-2.1

The map also indicates major cities where the three units operated in northern Iraq, including the two largest cities in northern Iraq, Mosul and Tal Afar. These cities lie in the northern portion of the large Sunni triangle. Mosul is the third-largest city in Iraqi after Baghdad and Al Basrah. Mosul, like Baghdad, is multiethnic and has

become a key battleground for insurgent forces. In contrast, Basrah is populated predominantly by Shiites and has seen much less violence than Mosul or Baghdad.

Figure 2.1 also shows the cities where the 3/2 SBCT operated in support of other units during uprisings in central Iraq. The 3/2 SBCT frequently served as a theater-level quick response force (QRF), conducting significant out-of-area operations in Samarra, Baghdad, An Najaf, and Al Kut. The 1/25 SBCT also conducted out-of-area operations, most notably in and nearby Fallujah during the second battle of Fallujah in December 2004. The 1/25 SBCT conducted many fewer out-of-area operations than the 3/2 SBCT.

Figure 2.2 shows that Mosul has been the location of a large number of attacks against U.S. forces and a significant number of U.S. casualties. Later in the mono-

Figure 2.2
Locations of Frequent U.S. Military Casualties Between May 2003 and July 2005

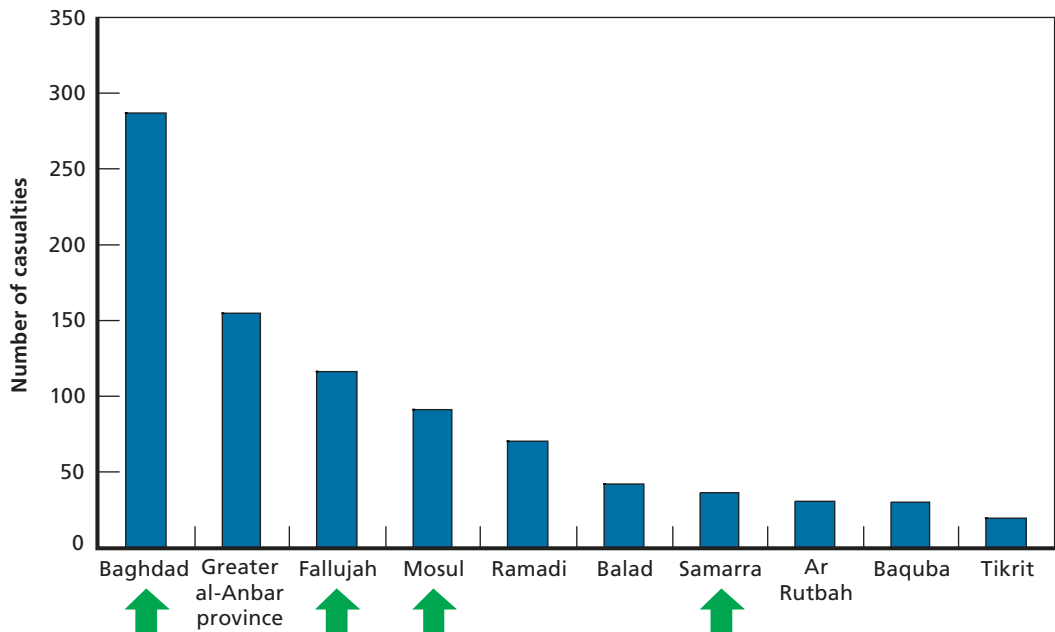

graph, we analyze in detail the level of insurgent activity and how it has changed over time in northern Iraq. This analysis shows that, for many periods of time, insurgent activities in northern Iraq were just as intense as those elsewhere in the country. Therefore, we can say with some justification that the three units we examine in this study were not placed in a relatively peaceful corner of the country where stability was fairly easy to establish.

Figure 2.2 shows where frequent U.S. military fatalities occurred between May 2003 and July 2005, along with the number of fatalities at each location. SBCT units have operated in at least four of the top ten most deadly areas: Baghdad (the most dangerous area), Fallujah (ranked third), Mosul (ranked fourth), and Samarra (ranked seventh). During their deployments, the Stryker brigades were involved in hundreds of engagements.

Characteristics of Anti-Iraqi Forces

The Iraqi insurgency and the tactics and weapons it employs changed significantly from the fall of Saddam Hussein's regime to late 2005. The insurgency is composed of many distinct and apparently independent elements. It uses asymmetric warfare tactics, making it difficult to fight with conventional means. Insurgency elements appear to be divided into distinct, geographically localized cells that have independent or highly decentralized command and control networks that are difficult to interrupt. Insurgents also have a substantial reconnaissance advantage. As opposed to coalition forces, which have high-signature vehicles and uniforms, insurgents usually wear civilian clothes. They hide in the large civilian population and can conceal their movements around Iraq and across Iraq's porous national borders. The modest logistical requirements for many of their attacks (small-arms fire, improvised explosive devices [IEDs], vehicular IEDs [VIEDs], mortars, and small ambushes), the easy availability of small-caliber weapons and explosives, and the inability of the coalition to date to penetrate insurgent organizations fully frequently provide insurgents the element of tactical surprise in their attacks. In many cases, they can prepare for such attacks as planting IEDs along roads without fear of exposure or compromise.

Insurgent organizations also have a fairly high degree of networking, with members using cell phones, satellite phones, and the Internet (email, Web sites, chat rooms, etc.). The use of the Internet by Iraqi insurgent groups has been documented in a

number of open-source analyses.¹ Reliable data that describe the level of the Internet access of the general Iraqi populace are not available. Nevertheless, it appears that Iraqi insurgent groups are able to gain access to the Internet either within Iraq or in nearby countries to post training materials, video recordings of attacks on coalition forces, and other propaganda.² Insurgent groups use the Internet to communicate via chat rooms and email. Their use of commercial telecommunications and the Internet has enabled the insurgents to adapt relatively quickly to changing conditions on the battlefield. Also, insurgent groups have proven adept at distributing videos of their attacks and communications to Middle Eastern and Western news organizations. According to some outside observers, their communication strategy with key segments of Middle Eastern society has in some ways been more effective than that of the United States. They have used these communications to try to turn popular opinion within Iraq and in neighboring countries against the United States and coalition forces. Some insurgent groups have also established effective means to exploit western and Middle Eastern media for propaganda purposes.

Iraqi insurgent groups have simple but extensive human intelligence (HUMINT) surveillance capabilities—for example, insurgents dressed as civilians use cell phones to send in reports or alerts whenever coalition units leave their base. Some of these HUMINT sources may not be hard-core insurgents. They may instead be only sympathizers or modestly paid low-level operatives. High unemployment in Iraq and the other factors have made Iraq fertile ground for “insurgents for hire.”³

Phases of the Insurgency

As a result of the distinct and independent elements that make up the insurgency in Iraq, the insurgency itself can be categorized by four specific phases (a more detailed

¹ Rita Katz, SITE institute director, presentation to the JIEDDO Intelligence Summit, Pensacola, Florida, May 2006.

² Katz, 2006.

³ Other factors include coalition operations against the wrong people or innocent civilians, which generate animosity and resentment against the coalition. Cultural and language barriers can add to the distrust and resentment of the local population (G. I. Wilson, Greg Wilcox, and Chet Richards, “Fourth Generation Warfare & OODA Loop Implications of the Iraqi Insurgency,” briefing, December 2004).

description of these four phases is presented later in this chapter).⁴ Phase one, the “Ba’athist phase,” from summer 2003 to winter 2003, was an insurgency comprised primarily of former Ba’ath party members and Saddam loyalists who employed guerilla warfare tactics and used more primitive weapons and IEDs. Phase two, the “Zarqawi phase,” from early 2004 to summer 2005, was spearheaded by Abu Musab al-Zarqawi and his organization, Jama’at al-Tauhid wa-l-Jihad. It used kidnappings and terrorist acts to capture the attention of the mass media. Phase three, the “national Islamist phase” from spring 2005 to winter 2005, witnessed the birth of more insurgent groups primarily focused on Iraq, such as the Islamic Army in Iraq, which consequently fostered competition among the separate insurgent groups and conflict between national Islamists and jihadists. Phase four, described by some as a civil war, began in early 2006, continues today, and is characterized by high levels of sectarian violence. For the purposes of this study, it is important to note that the rotation of the 101st ABD took place when the insurgency was predominantly in phase one, while the rotation of the 3/2 SBCT occurred during both phase two and the transition to phase three. Finally, the rotation of the 1/25 SBCT coincided with the end of phase two; during the majority of its rotation time, the 1/25 faced an insurgency in phase three. As a result, each unit faced an insurgency that differed, whether marginally or largely, from the insurgency faced by the other units. Consequently, differences in the leadership, tactics, techniques, and goals of the insurgent groups during these phases affected the counterinsurgency operations employed by the specific units in theater. We have carefully taken these factors and differences into consideration throughout the monograph.

Unit Organization

Previous case studies have shown it is important to change more than just communications technologies to gain the full benefits of NCO capabilities and, further, that NCO capability developments must include all DOTMLPF lines of development to provide the maximum benefit. Because organization is so important, we examine the organizational structures of the units in this section.

Figure 2.3 compares the organizational structure of the 101st ABD and the 3/2 SBCT and 1/25 SBCTs. As shown, the 101st ABD includes three infantry brigades,

⁴ These four phases are discussed in detail in Guido Steinberg, *The Iraqi Insurgency: Actors, Strategies, and Structures*, Berlin: Stiftung Wissenschaft und Politik, German Institute for International and Security Affairs, 2006.

Figure 2.3
101st ABD, 3/2 SBCT, and 1/25 SBCT Organizational Structures

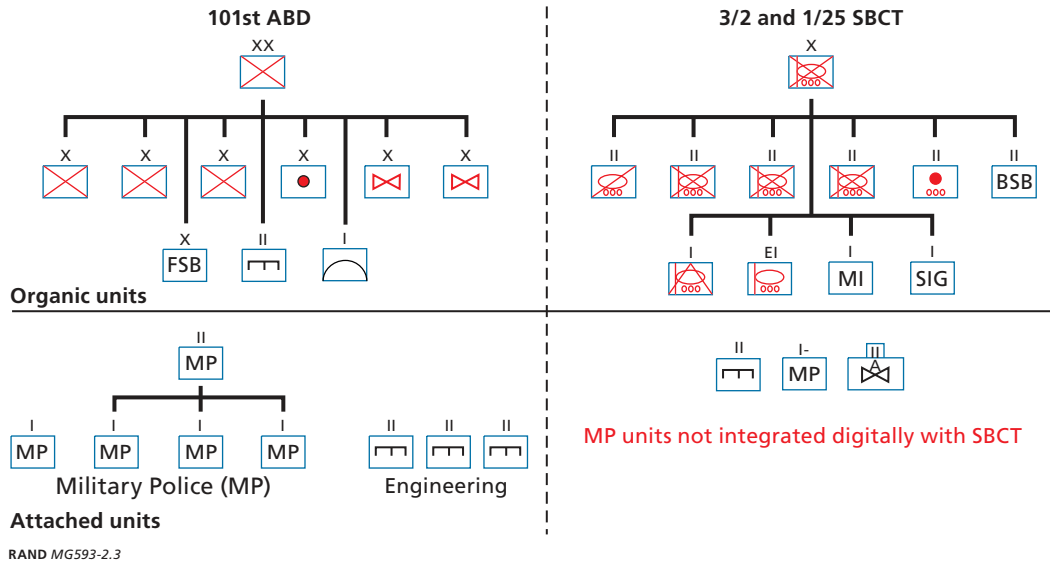

one artillery brigade, two aviation brigades (one assault and one support), a sustainment brigade, an air defense battery, and an engineering battalion. The 101st ABD also included a battalion and a company of military police attached in its first OIF rotation. In addition, the division also had three engineering battalions attached, which were important for reconstruction activities. The 101st ABD also began training ING units in its first OIF rotation. At the conclusion of its rotation, it had trained five ING companies and more than 3,000 police officers.

The 3/2 SBCT is much smaller than the 101st ABD. It has three mechanized infantry battalions, one RSTA squadron, one artillery battalion, one brigade support battalion (BSB), one mechanized anti-armor company, one engineering company, one MI company, and one signals (SIG) company. Not shown in the figure, but nevertheless significant from an organizational standpoint, the 3/2 SBCT also coordinated 12 ING battalions that operated in its area of operations, placing a significant burden on the brigade's headquarters. In comparison to the 101st ABD, the 3/2 SBCT had many fewer MP and engineering units attached, as indicated in the figure.

During its rotation in OIF, the 3/2 SBCT also had much less aviation support; the 101st ABD had more than 100 UH-60 Black Hawk helicopters available, whereas the 3/2 SBCT initially had only four UH-60s and eventually only ten. The 3/2 SBCT also had the support of 24 OH-58D Kiowa Warrior reconnaissance helicopters. However, the 3/2 SBCT had well over 300 Stryker armored vehicles available; the 101st ABD had none.

In terms of manpower, the 101st ABD is also significantly larger than either the 3/2 SBCT or the 1/25 SBCT. There are approximately 17,000 soldiers in the 101st ABD but only approximately 5,000 soldiers in a Stryker brigade.

Other units not shown in Figure 2.3 provided additional logistics and intelligence support to both types of units. The 3/2 SBCT was part of Task Force Olympia, which was also headquartered in northern Iraq. Special operations forces (SOF) had operated in northern Iraq since the very beginning of OIF and during the deployments of 101st ABD, the 3/2 SBCT, and 1/25 SBCT in northern Iraq. Some sources have indicated that more SOF units operated in northern Iraq when the Stryker brigades operated in this area. However, we have not been able to confirm this. A more complete discussion of the larger coalition ground-force structure in northern Iraq is classified and will not be discussed further in this monograph.

Areas of Operation

In this section we describe the specific areas of operations these units were responsible for in northern Iraq. Both the 101st ABD and the 3/2 SBCT conducted stability operations over a large area of operations (AO) in northern Iraq, which has been designated *AO North*. This area, illustrated in Figure 2.4, includes the Iraqi provinces of Ninawah, Duhuk, Arbil, and As Sulaymaniyah. The latter three provinces are predominantly populated by people of Kurdish descent. A sizable Sunni population exists in the Ninawah province of northern Iraq, but a much smaller proportion of the population of the other three provinces is of Sunni descent. That region has been governed autonomously by Kurdish political leaders since the end of the first Gulf War, when Iraqi Army forces withdrew from many parts of northern Iraq and U.S. air forces established a no fly zone north of the 36th parallel. Consequently, after the fall of Saddam's regime in April of 2003, there was little instability in these Kurdish areas, and the Iraqi insurgency never had a large-scale presence in Duhuk, Arbil, or As Sulaymaniyah provinces.

Figure 2.4
101st ABD and 3/2 SBCT Area of Operations



RAND MG593-2.4

The area shown in Figure 2.5 was the area of responsibility for Task Force Olympia, a U.S. Army division headquarters. This area is approximately 42,500 km² in size and borders Turkey and Syria.

Figure 2.5
The 1/25 SBCT Area of Operations



RAND MG593-2.5

The 1/25 SBCT, the third army unit responsible for northern Iraq, was given responsibility for the AO shown in Figure 2.5, which includes the two provinces of Ninawah and Dahuk. The area of responsibility for Task Force Olympia remained unchanged during the rotation of the 1/25 SBCT. During the first half of its rotation,

the 1/25 SBCT was the only maneuver brigade available in the Task Force Olympia in AO North. If additional military forces were required in the other provinces of AO North not highlighted in Figure 2.5, elements of the 1/25 SBCT would in all likelihood have been called on to deploy into those other provinces.

In September 2005, toward the end of the 1/25 SBCT rotation, the city of Tal Afar in Ninawah province was occupied by elements of the 3rd Armored Cavalry Regiment (ACR) during Operation Restoring Rights. From June 2004 to February 2005, other elements of the 3rd ACR conducted border security operations along the Iraqi-Syrian border in Ninawah province. Prior to this deployment, the 3/2 and 1/25 SBCTs only stationed a single company in Tal Afar, and even this force presence was intermittent. The 3rd ACR was able to drive insurgents out of Tal Afar by the beginning of 2006.⁵

The deployment of the 3rd ACR appears to have been a tacit admission that the Ninawah province was too large and too populous (2.5 million people) to be secured effectively by a single Stryker brigade.

AO Sizes, Personnel, Funding, and Attached Units

Table 2.1 compares the size of the AOs, troop levels, and key units that were attached to the lead U.S. unit for the AO. Figure 2.4 indicates that the 101st ABD and the 3/2 SBCT were successively responsible for the same AO, which has an area of approximately 63,900 km². The 1/25 SBCT AO in northern Iraq was smaller, at approximately 42,400 km², and included the two Iraqi provinces indicated in Figure 2.5. Even this smaller AO is well over an order of magnitude larger than the intended AO size (2,500 km²) for an SBCT, as described in the SBCT operational and organizational concept.⁶ The numbers of Iraqi civilians living in the area of operations for each unit, and the number of soldiers in each unit are also indicated in the table. The total number of residents in the AORs ranged from 5.9 million to 4.3 million. However, most operations in northern Iraq for all units were concentrated in Ninawah province, which has an estimated population of 2.5 million; operations were further concen-

⁵ George Packer, "Letter From Iraq; The Lesson of Tal Afar," *New Yorker*, April 10, 2006.

⁶ U.S. Army Training and Doctrine Command (TRADOC), *Interim [Stryker] Brigade Organizational and Operational Concept*, Ft. Leavenworth, Kansas, June 30, 2000.

Table 2.1
Unit Areas of Operation, Resident Iraqi Populations, U.S. Troop Levels, and Attached ING Units

	101st ABD	3/2 SBCT	1/25 SBCT ^a	1/25 SBCT + 3rd ACR ^b
Area of Operations (km ²)	63,900	63,900	42,450	42,450
Resident population	~5.9 million; 2.5 million in Ninawah	~5.9 million; 2.5 million in Ninawah	~4.3 million; 2.5 million in Ninawah	~4.3 million; 2.5 million in Ninawah
Number of U.S. troops	17,000	5,000	5,000	10,200
U.S. troops per 1,000 residents	Total: 2.9 Ninawah: 6.8	Total: 0.85 Ninawah: 2	Total: 1.2 Ninawah: 2	Total: 2.4 Ninawah: 4.1 Mosul: 2.8
Iraqi National Guard battalions	~5	5–8	8–12	8–12
Iraqi police	3,000	5000– >300	9,000	9,000
Iraqi and U.S. security forces per 1,000 residents ^c	~4.0	~2.3–1.8	~4.6–5.2	~5.8–6.4

SOURCE: http://www.world-gazetteer.com/r/r_iq.htm.

^a U.S. forces responsible for AO from October 2004 to May 2005.

^b U.S. forces responsible for AO from June 2004 to October 2005.

^c Assuming an average of 700 soldiers per ING battalion.

trated in Mosul, which has an estimated population of 1.8 million. The 101st ABD has over three times as many soldiers as the SBCT, which has only about 5,000.

Table 2.1 also presents the ratios of U.S. and coalition soldiers per thousand residents. Historically, ratios of ten or more soldiers per thousand have been the norm for stability operations; ratios of four to ten soldiers per thousand have sometimes been sufficient, but at the historical cost of carrying out harshly punitive acts against the population; and ratios of one to four soldiers per thousand have been sufficient only for routine policing, such as in post–World War II Germany, and not for fighting well-organized and financed insurgencies.⁷

⁷ Quinlivan, 1995.

The table shows that this ratio for U.S. soldiers in Ninawah province was 6.8, in the intermediate range (four to ten per thousand), under the 101st ABD. In contrast, the 3/2 and 1/25 SBCTs had force presence ratios of 2 in Ninawah province, where insurgents have concentrated their efforts in northern Iraq. This is in the historically “policing only” range. Note that towards the end of the 1/25 SBCT rotation, the 3rd ACR was deployed to Ninawah province to bolster U.S. force presence in Tal Afar and along the Iraqi-Syrian border. At that time, the U.S. force presence in Ninawah province increased to 4.1, as indicated in the table. Table 2.1 also indicates that coalition force presence was higher in northern Iraq if Iraqi security forces are included (the coalition force presence numbers in the last row of the table are for the entire AO of unit and in the case of the SBCTs include force presence estimates for the beginning and end of a unit’s rotation). These numbers should be viewed with some skepticism, however, because Iraqi police have been known to be infiltrated with insurgents, and Iraqi Army units are sometimes not well equipped or trained and have not always been reliable.

During its first rotation in OIF, the 101st ABD had significantly more funding available to fund humanitarian assistance (HA) projects in its AO. The 101st ABD disbursed at least \$31 million in command emergency response program (CERP) funding for over 5,000 reconstruction projects during its tenure in northern Iraq.⁸ This was primarily due to the fact that reconstruction and humanitarian assistance funding was allocated to military units on the basis of their size, so a division received a division-sized slice of the available funding, while a brigade would typically receive a brigade-sized slice of available funding.⁹ Consequently, a brigade received about a third of the funds a division received. Later, after the inequities of this system became apparent, a modestly larger amount of HA and reconstruction funds was allocated to the 3/2 SBCT. We were unable to obtain comprehensive quantitative data regarding reconstruction and HA funding shares distributed to each unit in northern Iraq. The

⁸ See “Lessons of the Iraq War and Its Aftermath,” *PolicyWatch*, No. 855: Special Forum Report Featuring David Petraeus, Washington, D.C.: The Washington Institute for Near East Policy, April 9, 2004; and LT GEN David H. Petraeus, “Learning Counterinsurgency: Observations from Soldiering in Iraq,” *Military Review*, January–February 2006.

⁹ Humanitarian assistance funds typically came from CERP accounts, which were allocated according to the size and military unit.

3/2 SBCT was able to fund more than 340 humanitarian assistance and reconstruction projects, including

- 87 related to education
- 50 related to health
- 136 related to transportation
- 64 related to water quality and distribution.

Similar data for the 1/25 SBCT were not available.

One review of reconstruction efforts in northern Iraq indicates that the 101st ABD did an excellent job of reconstruction and made good use of the substantial funds and the three engineering battalions it possessed to support these efforts. MGEN Petraeus, commander of the 101st ABD at the time, observed that in Iraq “money is ammunition” and measurable results could be reached by effectively spending funds in a timely manner once available.¹⁰ Furthermore, the troops in the 101st ABD recognized the need to act quickly, specifically when transitioning from military operations to reconstruction efforts, in order to be perceived favorably by the populace. As a result, in about seven months, and with the help of CERP funds, the 101st ABD undertook several significant reconstruction projects, such as repairing roads, the major bridge between Arbil and Mosul, irrigation systems, police stations, Mosul University, and other educational facilities.¹¹ In addition, the 101st ABD purchased equipment for Iraqi forces, paid civil servants, and established several information projects (e.g., Mosul TV).¹² The operations of the 101st ABD were largely viewed as successful because of the division’s ability not only to effectively conduct military operations but also to fund and complete major reconstruction efforts in a condensed time period without losing the support of the local populace.

Another important dimension to the stability operations these units conducted in northern Iraq is the training they provided to ING units and Iraqi police, as well as the command-and-control and liaison relationships that were established between U.S. military and ING units.

After news had spread that the administrator of the Coalition Provisional Authority (CPA), Ambassador Paul Bremer, had disbanded the Iraqi Army, former Iraqi mili-

¹⁰ Petraeus, 2006.

¹¹ “Lessons of the Iraq War and Its Aftermath, 2004; and Petraeus, 2006.

¹² “Lessons of the Iraq War and Its Aftermath, 2004; and Petraeus, 2006.

tary personnel who were uncertain whether they would receive future wages rioted in Mosul in July 2003. The Iraqi police responded to the riots and several demonstrators were killed. Shortly thereafter, the Mosul police force collapsed and the 101st ABD had to reenter the area and establish order.

A new police chief was appointed, and the police force was rebuilt and trained by elements of the 1st Armored Division. By the end of the 101st ABD's initial rotation in OIF, the police department had more than 3,000 police officers.

As described later in this section, during the transition of authority from the 3/2 SBCT to the 1/25 SBCT, the Mosul police department collapsed again. We describe the details of these events later in this chapter. Here, we only wish to point out that the Mosul police department appears to only have been marginally effective in combating violence and maintaining order in the city during the tenure of the 3/2 SBCT. The dramatic difference in performance of the Iraqi police during the rotations of the 101st ABD and that 3/2 SBCT are due in part to the number of U.S. military police (MP) units that were available in northern Iraq. The 101st ABD had three times as many MPs than were available during the 3/2 SBCT's rotation. During the tenure of the 101st ABD, MP liaison officers were stationed at all 14 police stations in Mosul. This was not the case during the tenure of the 3/2 SBCT.

After the second collapse of the Mosul police department in November 2004, it was rebuilt again during the rotation of the 1/25 SBCT (see the next section for a detailed analysis of this event). The police department had over 9,000 police officers at the end of the 1/25 SBCT's rotation.

The value of military police liaison officers in stability operations can be understood from the standpoint of NCO theory. The Iraqi populace and members of the Iraqi police department may be unwilling to stand up against and fight insurgents if they do not believe they will be supported and backed up by U.S. military forces. A level of trust has to be established between the police officers and U.S. military forces. The MPs play a key role in this process. This level of trust must be maintained either by regular phone communications or face-to-face meetings. This was much harder to do in the case of the Stryker brigades because of the reduced number of MPs they had available to support this liaison function.

It is possible that cell phones enabled these liaison or social networking functions to be more effectively carried out during the tenure of the 1/25 SBCT. We do not have the data to prove this hypothesis. We do know, however, that there was no cellular telephone network in northern Iraq prior to the war or during the rotation of the 101st ABD. We also know that such a cell phone network was well developed and

in widespread use during the tenure of the 1/25 SBCT. What we do not know is when this network came online in northern Iraq or when during the tenure of the 3/2 SBCT Iraqi police officers or police captains were issued cell phones or other means to communicate with U.S. MPs.

Timeline of Events

The insurgency and the operational environment have changed significantly since the collapse of the regime of Saddam Hussein. In the immediate aftermath of the fall of the regime, there was widespread looting and a general breakdown of law and order in many parts of Iraq. The state apparatus of the previous regime collapsed, and Ba'athist party members and others withdrew from their official positions of authority in society. But even then, signs that an insurgency could take hold in Iraq were apparent. During the invasion of Iraq, U.S. forces encountered irregular paramilitary forces, i.e., members of the Fedayeen Saddam, which fought ferociously using asymmetric tactics against U.S. forces, sometimes using civilian shields and civilian clothes and vehicles.¹³ After the fall of Baghdad, the Fedayeen Saddam and members of the Ba'athist party fled and took some time to reorganize and secure resources for their insurgent groups. While many Fedayeen were killed during the MCO phase of OIF, many survived and probably joined different elements of the insurgency.

Northern Iraq During the 101st ABD Rotation

Baghdad fell on April 9, 2003. Almost immediately thereafter, Iraqi forces in northern Iraq deserted their posts and fled. Kurdish Peshmerga forces in the north advanced southward beyond the green line that traditionally had divided Iraqi and Kurdish military forces. Kurdish forces captured a town about 30 miles north of Mosul and threatened to take the city of Mosul itself. Iraqi police and local authorities in the town of Mosul evaporated and looting ensued. A small contingent of SOF moved into the city and temporarily prevented its occupation by Kurdish forces. Shortly thereafter, the 26th Marine Expeditionary Unit, which was afloat in the Mediterranean, was deployed without its armor or attack aviation assets to occupy Mosul. This occupation

¹³ CPT Brian North, "Communications Lessons Learned, 2D Brigade, 101st Airborne Division (AASLT)," Center for Army Lessons Learned, U.S. Army Training and Doctrine Command, Fort Leavenworth, Kansas, March 28, 2005, not releasable to the general public.

did not go well, however, especially after some Marines tried to raise the American flag above city hall. The Marine forces eventually had to retreat outside of the city to the Mosul airfield.¹⁴

On April 22, the 2nd Brigade of the 101st ABD arrived at the Mosul airfield and relieved the Marines.¹⁵ Shortly thereafter, COL Joseph Anderson, commander of the 2nd Brigade, and his soldiers occupied the city of Mosul to prevent further looting and rioting. Over the next few months, the 101st ABD helped to establish a local governing council and reestablish police departments and other government institutions in northern Iraq. At this early stage after the fall of the regime, ethnic tensions in the city of Mosul were running very high, especially between Sunnis and Kurds. The efforts of the 101st ABD toward promoting governance in the region helped reduce ethnic tensions. Leaders of the 101st ABD spent a considerable part of their time establishing and maintaining contacts with local religious and political leaders in different parts of the region and assisting new Iraqi leaders in restoring government functions.¹⁶ The Ninawah provincial police force was reconstituted with assistance from the 101st ABD. By the end of the division's rotation, the police force consisted of over 3,500 officers. The leadership of Major General Petraeus and Colonel Anderson has been cited as instrumental in establishing local government institutions in northern Iraq and enhancing stability in the region.¹⁷ The commanders of the 101st ABD were able to broker a deal with the Sunni leaders to join the local governing council that was established. Provincial elections were held for many positions, and a mayor acceptable to all factions was appointed.

Efforts were also made to recover the assets hidden by former regime members and to use them for the reconstruction of the country. Initial plans were drawn up for the repair and reconstruction of Iraqi infrastructure. As mentioned earlier, over 5,000 reconstruction projects were started in northern Iraq.

¹⁴ Michael R. Gordon, "101st Airborne Scores Success in Reconstruction of Northern Iraq," *New York Times*, September 4, 2003; Michael R. Gordon and Bernard E. Trainor, *Cobra II: The Inside Story of the Invasion and Occupation of Iraq*, New York: Pantheon, March 2006.

¹⁵ The 101st ABD participated in several key operations during the major combat phase of OIF. Units of the 101st ABD were redeployed from central to northern Iraq in April of 2003. These units remained in northern Iraq until January 2004.

¹⁶ Interview with COL Joseph Anderson, former Commander 2nd BCT, 101st ABD.

¹⁷ Interview with COL Joseph Anderson.

Another major mission for the 101st ABD, from May 2003 to January 2004, the end of its rotation in northern Iraq, was to conduct high-value target (HVT) capture operations with SOF operating in the region. Initially many of these operations were focused on capturing former members of the Ba'athist regime. Early on, many key leaders of the former regime were still at large, including Saddam Hussein. This led to a concerted effort by U.S. forces throughout the country to capture key leaders of the former regime in HVT cordon-and-search operations. A deck of playing cards with the names and photographs (when they were available) of the 52 most-wanted former regime members was distributed widely to U.S. forces. These missions would frequently lead to dry holes or only to the capture of low-level operatives, but they also resulted in the acquisition of valuable intelligence information that was used to support later operations. After the initial capture of a dozen or so high-level leaders, it became increasingly difficult to locate many other HVTs in the “deck of cards.”

As noted earlier in this chapter, the rotation of the 101st ABD took place when the insurgency was predominantly in phase one. During this Ba'athist phase, Saddam Hussein had not yet been captured and Saddam loyalists made up the majority of the resistance facing the U.S. military. The insurgency primarily used guerrilla warfare tactics along with some successful suicide bombings. However, these bombings took place more infrequently than in subsequent phases, and the weapons used were much more rudimentary and primitive. The primary insurgent group at this time was the Army of Muhammad; however, their decreasing influence marked the end of this phase and the emergence of phase two, with Zarqawi as the prominent insurgent figure leading the resistance against U.S. and coalition forces.

During this time, U.S. forces in Iraq could move relatively freely without the threat of IED attacks (see Figure 2.6). However, they frequently encountered ambushes from former regime members or other groups hostile to U.S. forces. It appears that during this time members of the former regime were in the process of organizing an insurgency, but insurgent cells using sophisticated tactics had not yet been established in many areas.

Insurgent attacks in the spring and summer of 2003—typically, ambushes at close range using small arms and rocket-propelled grenades (RPGs)—did not end well for the attackers most of the time. Nevertheless, in late summer and fall of 2003, several local uprisings and relatively large-scale ambushes of U.S. forces, especially in the Sunni triangle, occurred, indicating that a local insurgency was growing and organiz-

Figure 2.6
Causes of Death for U.S. Troops (May 2003–June 2006)

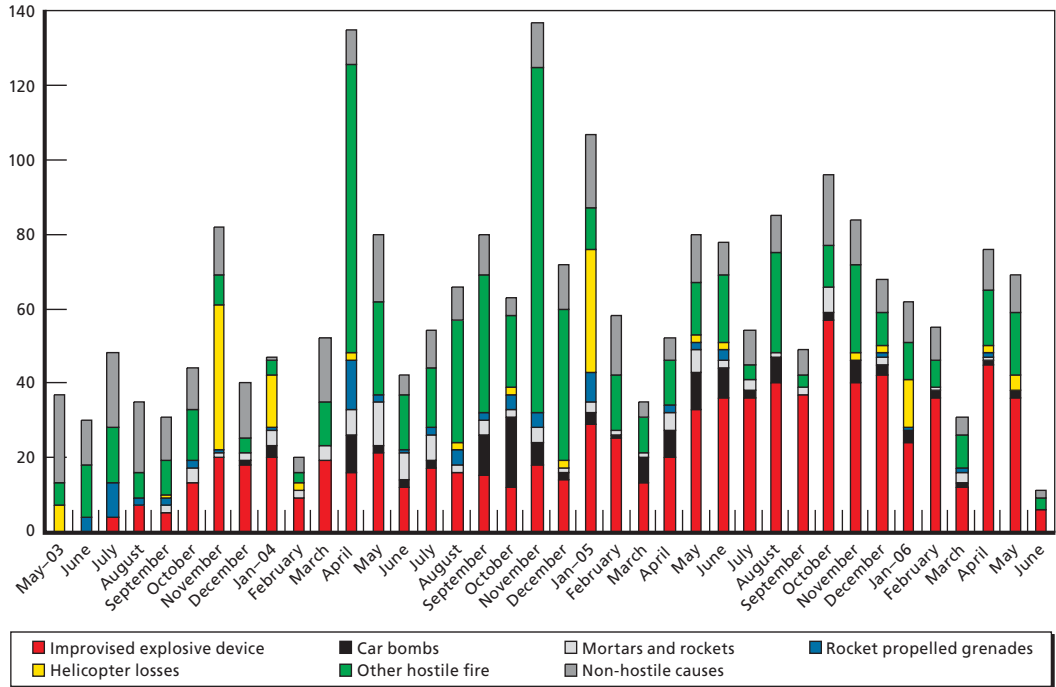

RAND MG593-2.6

ing. Perhaps this initial growth in the insurgency occurred when it became apparent to the Sunni population that they would soon be losing their privileged position in society as other ethnic groups started asserting local control in different parts of the country. During this time, U.S. HVT operations intensified. U.S. SOF and elements of the 101st Airborne Division located and killed Uday and Qusay Hussein, Saddam Hussein’s two sons, in a posh suburb of Mosul in late July 2003 after a fierce fire fight. In December 2003, Saddam Hussein was captured not too far from his home town of Tikrit, Iraq.

Northern Iraq During the 3/2 SBCT Rotation

The 3/2 SBCT was deployed to Iraq in November of 2003. It first maneuvered to Samarra in central Iraq to assist in quelling an uprising there. After helping to clear

Samarra of insurgents, the 3/2 Stryker brigade moved north to replace the 101st ABD in January 2004.

In late 2003 and early 2004, foreign fighters and terrorists started entering the country in sizable numbers. How these foreign fighters were organized outside of Iraq and how they were utilized inside the country is still not entirely clear. However, it was apparent from the early stages of the insurgency that Al Qaeda and affiliated terrorist movements played some role. In addition, by mid to late 2003, media reports indicated that several key former members of the Iraqi regime may have settled in Syria and established contacts with Sunni insurgent members in Iraq.¹⁸ These former regime members may have helped to funnel foreign fighters and resources into Iraq to fuel the insurgency.

In addition, as mentioned earlier, the rotation of the 3/2 SBCT occurred during both phase two and the transition to phase three. The insurgency during phase two, or the Zarqawi phase, was marked by the emergence of Abu Musab al-Zarqawi as a dominant leader of the insurgency, as well as his organization, Jama'at al-Tauhid wa-l-Jihad. During this phase, the insurgency carried out an increasing number of spectacular attacks and kidnappings, which it broadcast widely using the Internet and other media outlets. This phase is also characterized by the increasing role of Shiite cleric Moqtada Al Sadr, who established his own group to resist the presence of U.S. and coalition forces. Phase three, the national Islamist phase, was marked by the creation of additional insurgent groups primarily focused on Iraq, which fostered competition between insurgent groups in addition to spawning a larger conflict between national Islamists and jihadists. As a result, the rotation of the 3/2 SBCT took place during a time marked by numerous insurgent groups with different leaders, different goals, and different and more destructive tactics than those witnessed in phase one.

By the spring of 2004, Sunni insurgents had become organized and foreign fighter terrorists groups had established a significant presence in the country. Sunni insurgents and foreign fighters essentially took over the city of Fallujah and other smaller towns in the Anbar province in the spring of 2004. On March 31, several U.S. contractors were killed in Fallujah. Later, four marines were killed by an IED, and the first siege of the city began.

In April 2004, the Shiite militia group, the Mahdi Army of Moqtada Al Sadr, attacked a coalition base in Najaf. This attack was apparently part of a coordinated uprising across central and southern Iraq that perhaps was intended to seize control of

¹⁸ "Is Syria Harboring Saddam?" *Middle East Intelligence Bulletin*, Vol. 5, No. 6, June 2003.

parts of the country ahead of the planned June 30, 2004, handover of power from the CPA to a new interim Iraqi government. Elements of the 1st Armored Division were deployed to the city to put down the uprising. In addition, a battalion-size task force of the 3/2 SBCT was deployed from Mosul to support the 1st Armored Division in Najaf. The Stryker task force was attacked several times by insurgents along its maneuver route. In these attacks, the insurgents displayed growing sophistication and intelligence-gathering capabilities.¹⁹

During the uprisings in the south in 2004, elements of the 3/2 SBCT were also deployed in other out-of-area operations on several occasions, as indicated in Figure 2.1. In fact, the 3/2 SBCT was employed as a theater response force many times during its rotation. Consequently, it appears that a true brigade-size force was not available for stability operations in northern Iraq for many periods during the 3/2 SBCT rotation. This may have had a detrimental effect on the ability of the 3/2 SBCT to support local government leaders and Iraqi security forces in Mosul and Tal Afar.

In July 2004, the governor of Ninawah province, who was also the mayor of Mosul, was assassinated while he was in transit to Baghdad for talks with leaders of the new interim Iraqi government. This event took place out of Ninawah province and beyond the control of the 3/2 SBCT. Unfortunately, it had negative repercussions in Mosul and may have helped create a power vacuum and reduce the legitimacy of the local government in northern Iraq.

There were several symptoms of an insufficient U.S. force presence in northern Iraq in 2004 during the 3/2 SBCT rotation. In September 2004, it became apparent that Tal Afar had been overrun by insurgents. Elements of the 3/2 SBCT attempted to clear the city of insurgents in September 2004.²⁰ Tal Afar has since been overrun by insurgents more than once. It was not until September 2006 that Tal Afar was stabilized by the 3rd Armored Cavalry Regiment.²¹

In November 2004, the Ninawah provincial police force collapsed, and the head of the police department fled Mosul. In Mosul and elsewhere in Iraq, the insurgents had started to target police stations and police officers. The collapse of an important local Iraqi security force worsened the security situation in northern Iraq, especially

¹⁹ The details of this rapid long-range maneuver are described in Chapter Four.

²⁰ Specialist Blair Larson, "Terrorists Flee Tal Afar in Face of Coalition," *Army News Service*, September 24, 2004.

²¹ Packer, 2006.

in Mosul.²² The collapse appears to have had several causes. As already mentioned, local police leaders may have lost faith in the 3/2 SBCT because of a lack of visible support and dialog (social networking). An equally significant cause appears to have been external—the influx of a significant number of Sunni insurgents from elsewhere in Iraq.

In late summer, U.S. forces engaged insurgents in the second battle of Fallujah. Prior to this battle, the city was cordoned off for several months and civilians were permitted to leave. Many Sunni insurgents left Fallujah and entered Mosul. The collapse of the Mosul police department coincided with an uprising in the city on November 11, 2004, during which the newly arrived insurgents seized many parts of the city and burned down police stations. A relatively small number of police and a greater number of Iraqi soldiers fought the insurgents. A majority of the police units, which traditionally have been dominated by Sunnis, fled and the insurgents were able to attack, destroy, or occupy police stations in many parts of the city. This happened a few days after the start of the U.S. Marines' assault on Fallujah. Some commentators claim the insurgents were able to capture \$40 million worth of arms and equipment.²³

As mentioned above, MGEN David Petraeus, commander of the 101st ABD, had reached a tentative understanding with the local Sunni Arab establishment in northern Iraq. Thousands of former army officers took a public oath renouncing the Ba'ath Party and had joined the political process. This understanding was undermined by the siege of Fallujah and the collapse of Iraqi security forces in Mosul in November 2004.

During 2004, the number of insurgent attacks in northern Iraq increased significantly. It appears that, by this time, several insurgent cells were operating in Mosul. Also, it is evident from Table 2.2 that there was an initial wave of IED attacks in the late fall and winter of 2004 throughout Iraq. These attacks caused significant U.S. casualties. After this initial wave of U.S. casualties due to IEDs, U.S. casualties fell for several months, perhaps because U.S. forces had devised effective countermeasures for the initial set of IEDs that were employed by insurgents.

In summary, the security situation deteriorated significantly in northern Iraq and elsewhere in the country in 2004. Insurgents had devised new tactics and weapons for use against U.S. forces, which caused significant casualties. Insurgents also became better organized and were able to share information effectively using several cell phone

²² MAJ Thomas Kane, "One Year Later, Success in Mosul," *Scimitar*, Vol. 4, No. 5, Baghdad, Iraq, February 3, 2006.

²³ Patrick Cockburn, "Diary from Mosul," *London Review of Books*. Vol. 27, No 10, May 19, 2005.

networks that had become operational in the country by this time. Terrorists and insurgents inside and outside Iraq made increasing use of the Internet during this time. This allowed them to share training materials, tactics, bomb designs, and other data far more rapidly than in the past.²⁴

Northern Iraq During the 1/25 SBCT Rotation

The 1/25 SBCT was deployed to Iraq in October of 2004 and replaced the 3/2 SBCT in northern Iraq that month. This Stryker unit remained in Iraq until October 2005. The 1/25 SBCT did not take its own vehicles and equipment to Iraq. Instead, it used the vehicles and equipment of the 3/2 SBCT to quicken the transition.

During the rotation of the 1/25 SBCT, the insurgency was transitioning from the end of phase two into phase three. As mentioned earlier, phase two marked an insurgent movement led by two main figures, Zarqawi and Al Sadr. The increasing number of insurgent groups led to a shift in the dynamics of the insurgency, and thus a transition into phase three, also referred to as the “national Islamist phase.” As the number of insurgent groups increased, so did the level of competition between these groups, resulting in not only a greater number of attacks directed toward U.S. and coalition forces, but also a higher level of sectarian violence. The weapons and tactics used by the insurgents were primarily suicide bombings and IED attacks, though attacks by mortars, RPGs, and small-arms fire continued as well.

The siege and second battle of Fallujah took place in October and November 2004. Elements of the 1/25 SBCT were diverted from Mosul and took part in this battle. The level of violence in Mosul and elsewhere in northern Iraq remained high in late 2004 and through early 2005.

In October 2004, Abu Musab Zarqawi pledged allegiance to Al Qaeda and to Osama bin Laden.²⁵ His insurgent group and others increased their level of cooperation with Al Qaeda groups outside of Iraq, which facilitated the movement of resources and foreign fighters into the country. Al Qaeda in Iraq became an increasingly important center of gravity in the insurgency that U.S. forces had to deal with. Al Qaeda in Iraq carried out significant operations in the Mosul area in late 2004 and throughout 2005, when the 3/2 and 1/25 SBCTs were operating there.

The number of IED attacks continued to increase in 2005 throughout Iraq. One open-source analysis of IED attacks showed they almost doubled—from 5,607 in 2004

²⁴ Katz, 2006.

²⁵ Katz, 2006.

to 10,953 in 2005.²⁶ U.S. casualties rose again in the spring and summer of 2005, as Al Qaeda in Iraq became more active and as other jihadist nationalist insurgent groups increased their level of operations. Attacks were also carried out by Shiite extremists in southern and central Iraq and by Sunni insurgents and Al Qaeda in northern, western, and north-central Iraq.

In 2005 and 2006, the insurgency raged unabated in many other parts of Iraq. The parts of the country least affected by the insurgency had the lowest proportional number of Sunni Arabs—in southern Iraq where Shiite leadership has taken firm local control and in the northern Kurdish areas of Iraq.

During the past few years U.S. counterinsurgency operations in Iraq have grown increasingly intense. As described in detail later in this report, the operational tempo (OPTEMPO) of the U.S. operations in northern Iraq grew significantly from mid 2003 to late 2005. The 1/25 SBCT conducted six and one-half times more operations than did the 101st ABD, and the 3/2 SBCT conducted one and one-half times as many operations as the 101st ABD (not including the many out-of-area operations this unit also conducted during the same period of time). CENTCOM data show that this increased OPTEMPO was most likely due to the significant increase in the insurgent and terrorist threat from mid-2003 (when the insurgency was just getting organized). It is not an exaggeration to say that the Stryker brigades operated in a significantly more difficult environment than the 101st ABD did during the post-MCO phase of OIF because of the later proliferation of the IED threat, the increasing surveillance and communications capabilities of the insurgents, and the increase in the number of insurgents in northern Iraq, many of whom came from other countries or from elsewhere in Iraq.

U.S. Casualties

Figure 2.7 tracks U.S. military casualties in OIF by month from March 19, 2003, to November 2005. The figure also shows the time periods during which the 101st ABD, 3/2 SBCT, and 1/25 SBCT were responsible for northern Iraq. This timeline

²⁶ Michael O'Hanlon and Nina Kamp, *Iraq Index: Tracking Variables of Reconstruction and Security in Post-Saddam Iraq*, Washing, D.C.: Brookings Institution, draft, June 8, 2006.

Figure 2.7
U.S. Military Casualties in OIF since March 19, 2003

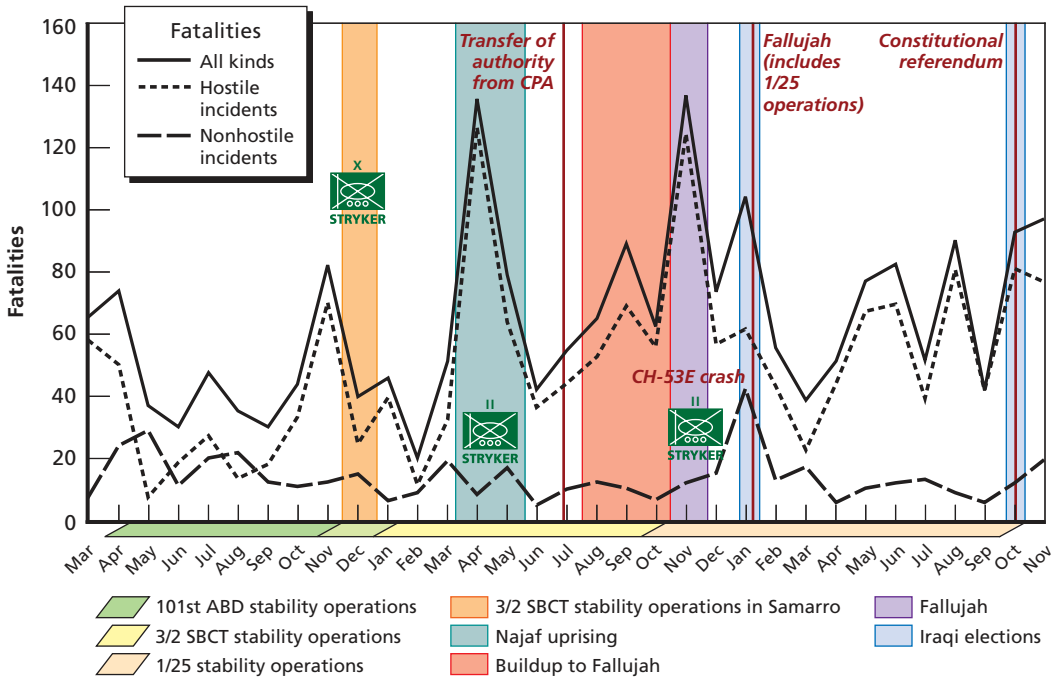

RAND MG593-2.7

corroborates the view that the 3/2 and 1/25 SBCTs were engaged in stability operations during a time of significant and growing insurgent violence as measured by U.S. military casualties (November 2003–November 2005).

The figure also shows two major out-of-area operations that elements of the 3/2 SBCT conducted in Samarra during the beginning of its rotation and later in An Najaf. U.S. casualties increased significantly during these periods, specifically because of these operations. Also shown is a significant out-of-sector operation that elements of the 1/25 SBCT conducted during the beginning of its rotation in and around Fallujah. Again, U.S. casualties increased significantly during the buildup to the battle of Fallujah and during the battle itself. All of these out-of-sector operations were conducted in response to rising insurgent activity in specific areas outside northern Iraq.

Another significant event that caused an increase in U.S. casualties throughout the theater was the Iraqi elections. During the first two Iraqi elections, one held in

January 2005 and the constitutional referendum that was held in October 2005, significant violence occurred throughout the country. Anti-Iraqi forces (AIF) attempted to disrupt the elections and discourage Iraqis from voting. Not shown on Figure 2.7 is the third Iraqi election for the new Iraqi government, which occurred in January 2006. Significantly, violence in the country was much reduced during that election and voter turnout in Iraq was higher than for any other postwar election.

It is useful to note that U.S. casualties were on average lower during the period of time 101st ABD was on station in northern Iraq compared to the periods of time when the 3/2 SBCT or the 1/25 SBCT were responsible for this part of the country. Later in this monograph, we will examine this issue more closely.

Force Networking, Quality of Information, and Quality of Shared Situation Awareness

In this chapter, we examine the networking and the command and control, or battle command, systems the 101st ABD and the two Stryker brigades were equipped with during their rotation in OIF. We then evaluate the effect of these systems on the quality of information, collaboration, and shared situation awareness within these units. We also consider the influence of the units' training and experiences on their shared situation awareness.

Networking Systems

101st ABD Network

Figure 3.1 provides a simplified view of the 101st ABD communications network that includes many of the key nodes within the division and adjacent or attached units. Below the brigade level, most division elements including combat vehicles and dismounted soldiers were connected by voice communications only; the voice radios were used to transmit blue force positions, spot reports, and command information. Communications on voice-only combat radios travel by line of sight (LOS), which means that the antennas of the sending and receiving radio must be inter-visible; LOS communications can be interrupted by terrain, buildings, and other types of interference.

A small number of command vehicles, the brigade and battalion tactical operations centers (TOCs), and about half of the helicopters in the division are equipped with FBCB2-BFT systems. These BFT systems are linked via satellite communications links and are part of the larger BFT network in the theater of operations. Each light infantry brigade in the 101st ABD was equipped with five to eight FBCB2-BFT sys-

Figure 3.1
101st ABD Infantry Brigade Network

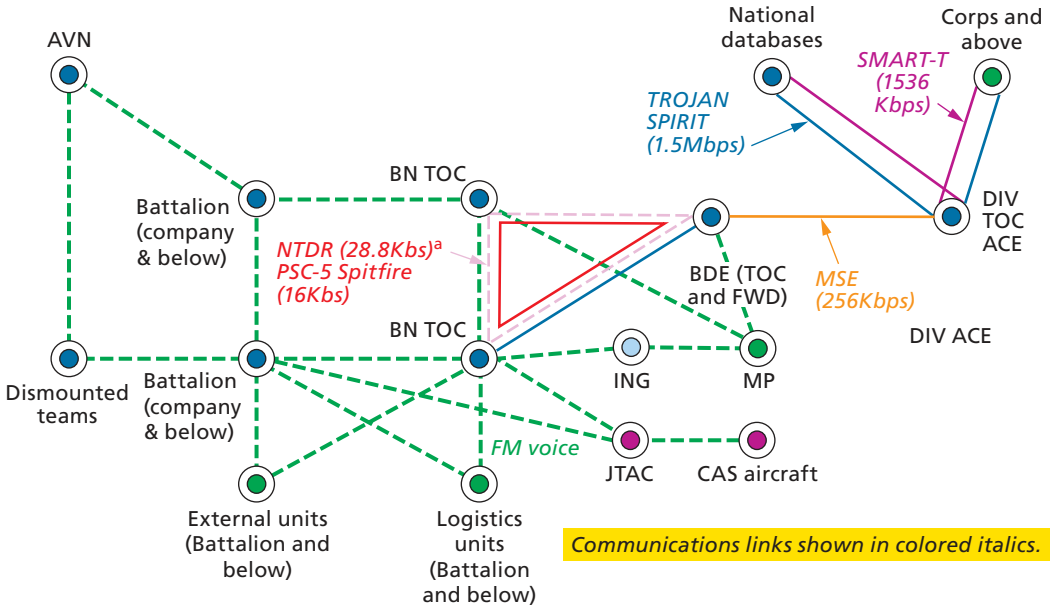

^a Note that NTDR between these nodes were not functional for much of the rotation.

NOTE: BFT satellite links not shown.

SOURCES: North, 2005; U.S. Army, 2003; interview with COL Joseph Anderson, former commander, 2nd BCT, 101st Airborne Division.

RAND MG593-3.1

tems.¹ Helicopters within the 101st ABD were also equipped with FBCB2-BFT (82 total).

Battalion and brigade TOCs are connected by several other systems, including the near-term digital radio (NTDR), which can provide a 28.8 kilobytes (Kbs) shared LOS data network when performing optimally, and PSC-5 Spitfire ultra high frequency (UHF) SATCOM terminals, which provide a 16 Kbs satellite link.²

¹ Interview with COL Joseph Anderson. Some data were supplied by COL Robert Ballew, Office of Force Transformation.

² Interview with COL Joseph Anderson; North, 2005.

The brigade TOC was linked to division level using the mobile subscriber equipment (MSE) network, which is a LOS microwave radio system that primarily provides phone communications. MSE includes a tactical packet network, as well, to provide data sharing.³

Command posts at the division level were connected with higher echelons using the SATCOM systems indicated in Figure 3.1: the Secure Mobile Anti-Jam Reliable Tactical Terminal (SMART-T) and TROJAN Special Purpose Integrated Remote Intelligence Terminal (TROJAN SPIRIT) systems (both provide links of about 1.5 megabits per second [Mbps]).⁴

Finally, mounted elements of the 101st ABD were linked to nearby dismounted teams and units outside the division through a variety of frequency modulation (FM) voice systems (notably the Single-Channel Ground and Airborne Radio System [SING-CARS]), or with the occasional FBCB2-BFT links mentioned above.

3/2 SBCT Network

Figure 3.2 provides a simplified view the SBCT communications network. It includes key nodes in the brigade and adjacent or attached units. All combat vehicles in the SBCT are connected over the FBCB2-EPLRS⁵ network, which shares blue force positions, spot reports, battle space graphics, command information, and text messages over a shared LOS wireless network. Within the Army EPLRS network, the effective average point-to-point data rate is 14.4 kbps. The SBCT has significantly greater tactical networking capabilities than Army “analog” units that are equipped only with voice radios. The 3/2 SBCT has over 600 FBCB2-EPLRS systems. In addition, command vehicles and the brigade and battalion TOCs are equipped with a total of 13 satellite-based FBCB2-BFT units.

Battalion and brigade TOCs are connected by several other systems. Initially, before deploying to Iraq, battalion and brigade TOCs were connected via NTDR,

³ North, 2005. Information in this paragraph is from U.S. Department of Commerce, “Plan to Select Spectrum for Third Generation Wireless Systems in the United States—Attachment 3, Spectrum Use Summary of the United States,” January 22, 2001.

⁴ North, 2005.

⁵ EPLRS is the Enhanced Position Location Reporting System. It provides identification, position location, and navigation information automatically to a centralized net control station. It reports this information to commanders and supported users with the EPLRS community upon request.

Figure 3.2
3/2 SBCT Communications Network

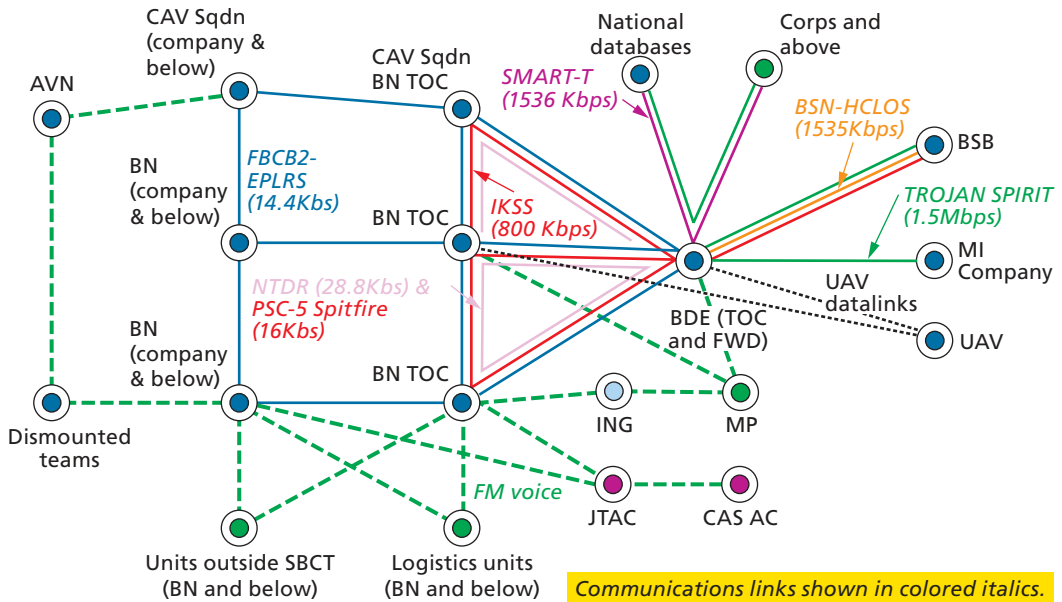

NOTE: BFT satellite links not shown.

RAND MG593-3.2

PSC-5 Spitfire, and MSE terminals, just like 101st ABD units. The 3/2 SBCT’s certification exercise at the JRTC showed a need for more reliable, higher-bandwidth communications.⁶ The Army responded by providing the Interim Ku-band Satellite System (IKSS), which links brigade and battalion TOCs with high-bandwidth commercial satellite links. Consequently, the SBCT did not rely on older MSE and NTDR equipment in theater.

The SBCT IKSS is a hub-and-spoke SATCOM network. It affords digital communications using the Internet protocol and thereby provides high bandwidth Secret Internet Protocol Router Network (SIPRNET) access and enables Stryker brigade soldiers to communicate using standard SIPRNET applications.

⁶ Daniel Gonzales et al., *Network-Centric Operations Case Study: The Stryker Brigade Combat Team*, Santa Monica, Calif.: RAND, MG-267-1-OSD, 2005a. pp. 52–53.

The IKSS network is illustrated in Figure 3.3. In its initial configuration with the 3/2 SBCT, it supplied 7–8 Mbps aggregate data rate. The IKSS network also features small antennas that require 45 minutes or less to set up, which is a major improvement over the setup times for older and larger SATCOM dishes.

At the brigade level, the brigade TOC was linked to higher echelons, the MI company, and the BSB through SMART-T and TROJAN SPIRIT SATCOM systems; the BSB was also linked to the brigade TOC via the Brigade Support Node (BSN)–High Capacity Line of Sight (HCLOS)⁷ high-capacity radio system (a 1.5-Mbs or greater link).

As with the 101st ABD, mounted elements of the SBCT were linked to nearby dismounted teams and units outside the SBCT through FM voice systems or with some external units using FBCB2-BFT links.

1/25 SBCT Network

The 1/25 SBCT network closely resembled that of the 3/2 SBCT. As in the 3/2 SBCT, all combat vehicles in the 1/25 SBCT were connected over the FBCB2-EPLRS network. Some significant enhancements were made to the network, however. First, brigade TOCs and some battalion and company TOCs were connected with high-speed fiber-optic communications links. Typically, only TOCs located on the same forward operating base are connected in this way. Second, the 1/25 SBCT's IKSS was upgraded to provide a 12 Mbps aggregate data rate rather than the 7–8 Mbps system the 3/2 SBCT had. Finally, the 1/25 SBCT had access to Rover III communications systems, which enabled real-time video downlinks from predator UAVs and selected strike aircraft.⁸

Rover III can receive fighter targeting pod (from modified Low Altitude Navigation and Targeting Infrared for Night [LANTIRN] targeting pods) and Preda-

⁷ The HCLOS radio provides additional bandwidth to help transfer voice, video and data around the battlefield. See Paul Fisher and Fred Stein, "Digitally Deployed (Signal Transformation in Combat): 3/2 Stryker Brigade Combat Team Operation Iraqi Freedom," *Army Communicator*, Summer 2004.

⁸ U.S. Army Infantry School, 1/25 Stryker Brigade Lessons Learned Conference, Fort Lewis, Washington, February 7–8, 2006, not releasable to the general public; interviews with Stryker soldiers, February 7–8, 2006.

Figure 3.3
IKSS Network

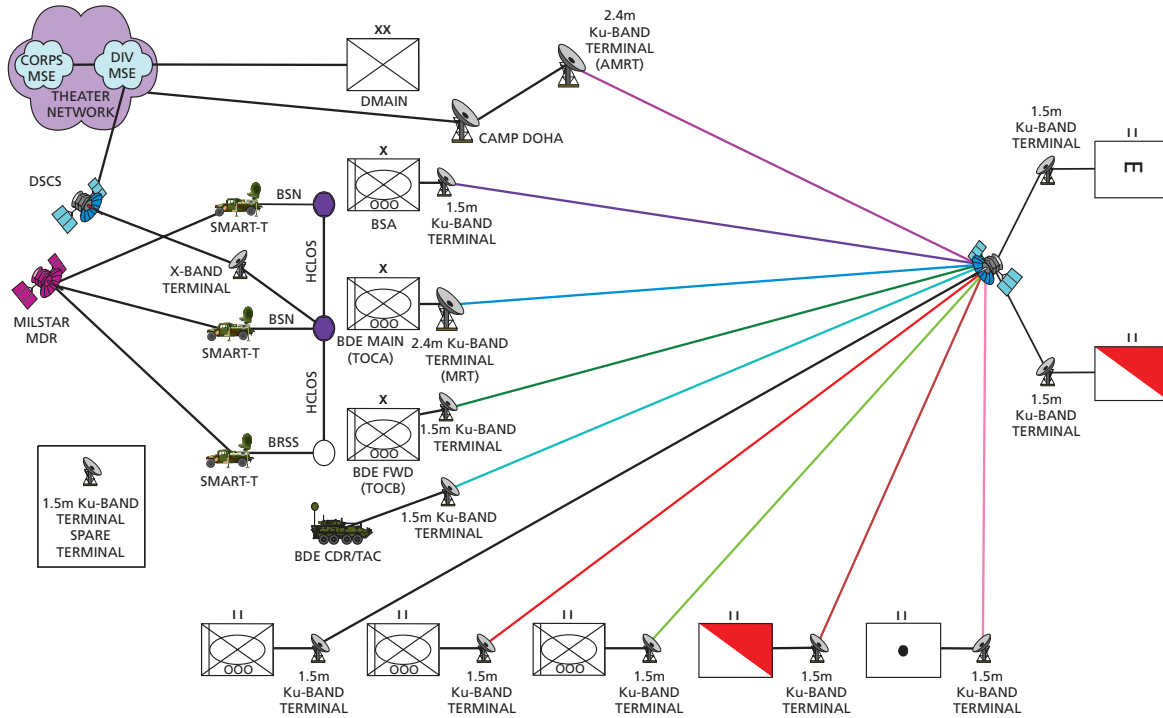

SOURCE: Fisher and Stein, 2004.

RAND MG593-3.3

tor imagery in real time. It was fielded to Air Force joint terminal attack controllers (JTACs) assigned to the 1/25 SBCT, and to SOF task force units that operated in northern Iraq. Rover III's imagery is illustrated in Figure 3.4.

Figure 3.5 describes the architecture used to control Predator UAVs using Rover III. The JTAC in collaboration with Stryker commanders on the ground used SIPRNET Multi-User Internet Relay Chat (MIRC)⁹ and Rover III to retask Predator in real time and to locate and identify targets, as illustrated in Figure 3.5. MIRC chat was necessary for this operation because the Stryker company commander on the ground would usually not have direct access to Predator imagery (as he would usually not be co-located with the JTAC). Thus, the JTAC normally acted as a relay to control the Predator sensors and to exploit Predator imagery for the company commander.¹⁰

Figure 3.4
UAV Imagery Received by Rover III



RAND MG593-3.4

⁹ MIRC is the military equivalent of an Internet chat room.

¹⁰ Interviews with Stryker soldiers, February 7–8, 2006.

Figure 3.5
Predator Control Using Rover III and SIPRNET MIRC

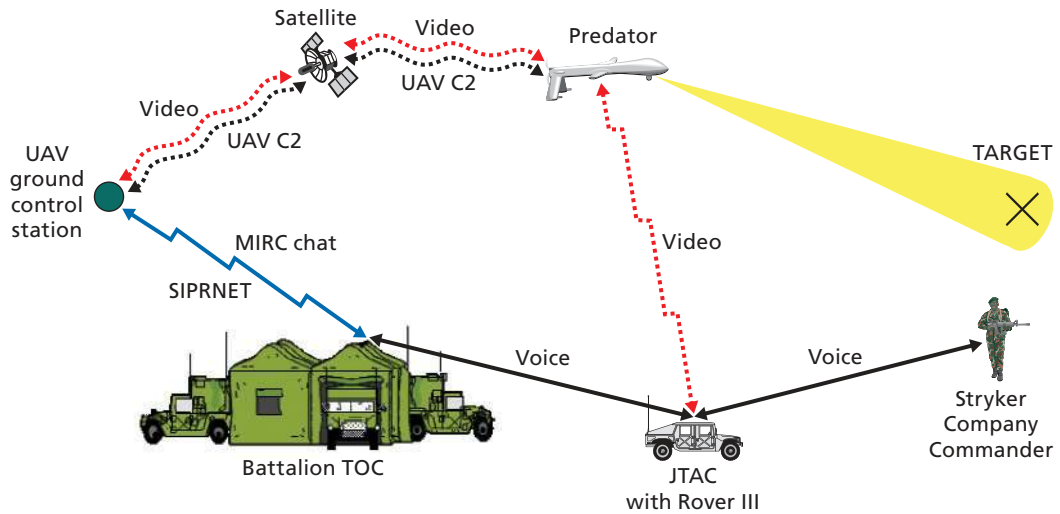

SOURCE: U.S. Army Infantry School 1/25 Stryker Brigade Lessons Learned Conference, 2006; Interviews with Stryker soldiers, February 7–8, 2006.

RAND MG593-3.5

Battle Command Systems for the 101st ABD, 3/2 SBCT and 1/25 SBCT

Figure 3.6 diagrams the 3/2 SBCT’s C2/battle command (C2/BC) systems. For the 3/2 SBCT, the core C2/BC system was FBCB2. TOCs also had the following systems:¹¹

- *Maneuver Control System (MCS) both light and heavy variants.* MCS is a C2 system that automates the creation and distribution of a common operational picture of the battlefield. Its network of computer terminals processes combat information for battle staffs, providing both text and graphics.
- *All Source Analysis System (ASAS).* ASAS fuses intelligence from multiple sources and automates the sensor-to-shooter link. Note that intelligence officers (S2s) frequently maintained their own internal intelligence databases using Microsoft Access and Excel in addition to ASAS.

¹¹ U.S. Army, *Army Battle Command Executive Overview*, Version 6.x, January 2003, not releasable to the general public.

Figure 3.6
C2/BC Systems

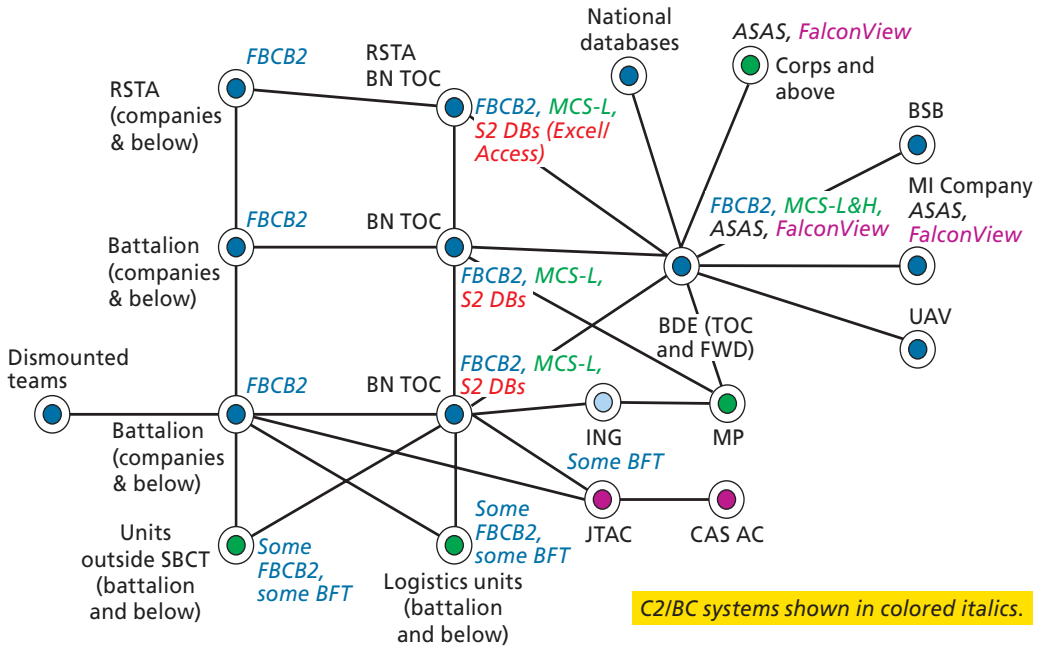

SOURCES: *Army Battle Command Executive Overview*, Version 6.x, (January 2003); Center for Army Lessons Learned, December, 2004; *OPERATIONS IN MOSUL, IRAQ IIR, Updated Final Draft*, 2005; North, 2005; U.S. Army, 2003.

RAND MG593-3.6

- *FalconView mapping system.* FalconView is a Windows mapping application that displays various types of maps and geographically referenced overlays.

Microsoft Office products (Word, PowerPoint, Outlook, and Access) were commonly used for communications and C2 purposes throughout the SBCT as well.¹² When available, SBCT units interfaced with outside units with FBCB2-BFT systems.

¹² Michael Rzeplinski, "Information Dissemination Management–Tactical (IDM-T)," undated briefing, Fort Monmouth, N.J.: IDM-T Program Office; Center for Army Lessons Learned, *Operation Iraqi Freedom Initial Impressions Report: Stability Operations, Support Operations*, Fort Leavenworth, Kansas.: U.S. Army Training and Doctrine Command, December 2003, not releasable to the general public.

Each 101st ABD Infantry brigade's suite of C2/BC systems was similar to the 3/2 SBCT's suite, except for the lack of FBCB2-EPLRS.

The 1/25 SBCT added several C2/BC systems to its suite of capabilities. These were mainly used by the MI company and the battalion and brigade S2s to store threat information and provide better representations and visualizations of insurgent threat networks. The primary new tools were Analyst's Notebook and CrimeLink. Both are commercial software programs that originate from the law enforcement community. The two software packages are not interoperable.¹³

Units in the 1/25 SBCT also introduced what it nicknamed the "CSI Mosul" personal digital assistant (PDA). This device was originally issued to logistics personnel in the Stryker brigade to store and update logistics information. It was found not to be useful for this purpose, so the systems were wiped clean and uploaded with HVT blacklist information that included photos and dossiers on high-value individuals. 1/25 SBCT soldiers would refer to the PDAs to check an individual's identification and compare him to photos in the blacklist.¹⁴

Summary

In the sections above we have described the NCO system enhancements made to the SBCTs that operated in northern Iraq. These enhancements are summarized in Table 3.1.

Effect of Networking Systems on Quality of Information

The NCO logic, discussed in Chapter One, states that a robustly networked force improves information sharing, and that improved information sharing combined with intelligence, enhances the quality of information.¹⁵ In this section, we consider the

¹³ 1/25 soldiers reported acquiring and using these tools at their lessons-learned conference (U.S Army Infantry School, 2006). More information about Analyst's Notebook is available online at the i2 Inc. Web site, <http://www.i2inc.com/>; more information about CrimeLink is available online at the Precision Computing Intelligence (PCI) Web site, <http://www.pciusa.us/default.aspx/>

¹⁴ Noted at the 1/25 Stryker Brigade Lessons Learned Conference, February 7–8, 2006.

¹⁵ We define a network as *robust* when it provides adequate bandwidth to transmit critical mission information without loss, corruption, or significant delay; when it maintains connectivity for tactical users regardless of how far they are from the brigade TOC or whether they are moving, and when it provides a full range of services

Table 3.1
NCO Enhancements in Northern Iraq

	101st ABD	3/2 SBCT	1/25 SBCT
FBCB2/BFT on AVN	40 AH-64 30 UH-60 12 CH-47 82 total	On helicopters supporting 3/2	On helicopters supporting 1/25
FBCB2/BFT per infantry brigade on C2 vehicles	5–8	13	13
FBCB2/EPLRS on ground vehicles			
Stryker vehicles	0	317	317
Other vehicles	0	~280	~280
Reliance on MSE/NTDR for brigade–battalion communications	Yes	No	No
IKSS SATCOM terminals	0	10	10
TeamSpeak/SIPRNET for brigade battle update brief	No	No	Yes 50–80 participants
Access to Rover III communications terminals	No	No	Yes Battalion level
Fiber-optic links	No	No	Yes Brigade TOC– battalion TOC– company TOC
PDA's or "CSI Mosul" information	0	0	Some infantry soldiers

 Factor with a relative disadvantage  Factor with a relative advantage

effect of the networking systems described above—and the information sharing capabilities they provide—on the quality of information available to the different units. We begin with general feedback on the quality of information the units had, as reported in surveys. We then consider the specific impacts the networking systems had on information quality, as reported by soldiers in lessons-learned documents and conferences.

needed to connect to other users in the joint task force, Army, and DoD networks. For a more detailed set of metrics for network robustness, see DoD, Office of Force Transformation (2004).

Survey Results on Quality of Information

To assess the quality of information and collaboration commonly experienced by the units, RAND surveyed 1/25 SBCT, 3/2 SBCT, and 101st ABD leaders. There were a total of 10 respondents for the 1/25 SBCT, out of 44 surveys sent out; 15 respondents for the 3/2 SBCT, out of 103 surveys sent out; and 14 respondents for the 101st ABD, out of 42 surveys sent out. While the results that follow can only be considered as indicative, given the small sample sizes, the samples did include a good cross section of leaders in the 101st ABD and the SBCTs. Further, there were some statistically significant differences between the responses of the SBCT and 101st ABD participants. Table 3.2 shows the breakdown of responses by unit role and rank, where available.

The first set of questions asked respondents to rate the completeness, trustworthiness, and timeliness of various types of information they received during cordon-and-search/knock-and-raid operations. Figure 3.7 reprints the survey question, the types of information rated, and the meanings of the ratings. The figure then graphs the average completeness, trustworthiness, and timeliness scores reported, along with the average of all three metrics.

Figure 3.7 shows the cases in which the SBCTs' average quality-of-information scores differed by a noticeable margin from those of the 101st ABD: information on known forces and neighborhoods (SBCTs' were higher) and information on Iraqi leaders and security forces (SBCTs' were lower, except that the 3/2 SBCT reported a higher quality of information on the Iraqi National Guard). There was little difference in scores between units. For all units, information quality on their own forces was much higher than other types of information quality.

The second set of questions asked respondents to rate the completeness, trustworthiness, and timeliness of various types of information they received during convoy operations. Figure 3.8 reprints the survey question, the types of information rated, the meanings of the ratings, and the resulting average scores from units. In comparison with cordon-and-search and knock-and-raid operations, there were many more noticeable differences in quality of information between the SBCTs and the 101st ABD. SBCT respondents reported greater information quality for enemy positions, enemy TTPs,

Table 3.2
Breakdown of Survey Responses by Rank and Unit Role

Division		101st ABD	
Commander			
Aide de Camp	1 (04)		
G2	1 (04)		
G3			
Brigade		3/2 SBCT	1/25 SBCT
Commander			
XO/Deputy Commander	1 (04-P)	1	
S2	2 (03/04)		
S3	1 (04)		
Information Operations		1	
Battalion			
Commander			
XO	1 (04)		3 ^a (04)
S2		1	3 (02, 03)
S3		4	3 ^a (04)
Company			
Commander			
	1 (03)	6	3 (03)
Others			
Signal Officer			
		1	
CW3	1		
Operations Sergeant		1	

^a 1/25 SBCT reported usually rotating personnel between XO and S-3 positions, so the same three respondents served as both XO and S-3 at different times.

^b Received one 1/25 SBCT response without identifying information.

IED positions, IED types, and information on own forces. As with cordon-and-search and knock-and-raid missions, information quality on own forces was much higher than that of other types of information.

Figure 3.7
Quality of Information for Cordon-and-Search and Knock-and-Raid Missions

Survey Question: We want to know about the quality of information that was available to you during the preparation stage of cordon & search/knock and raid missions. How would you rate the information you had about the following things in the left-hand column of the table?

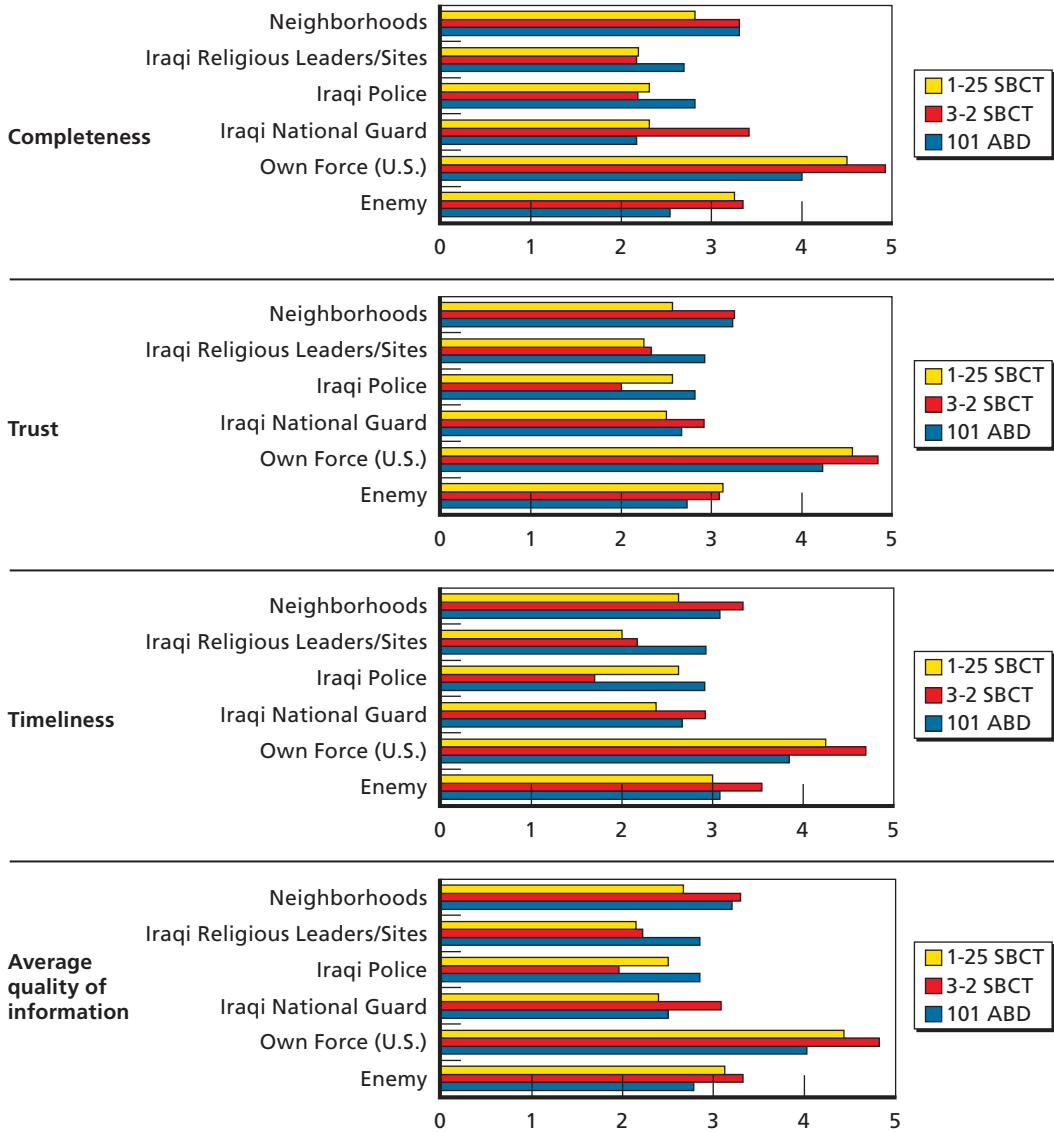
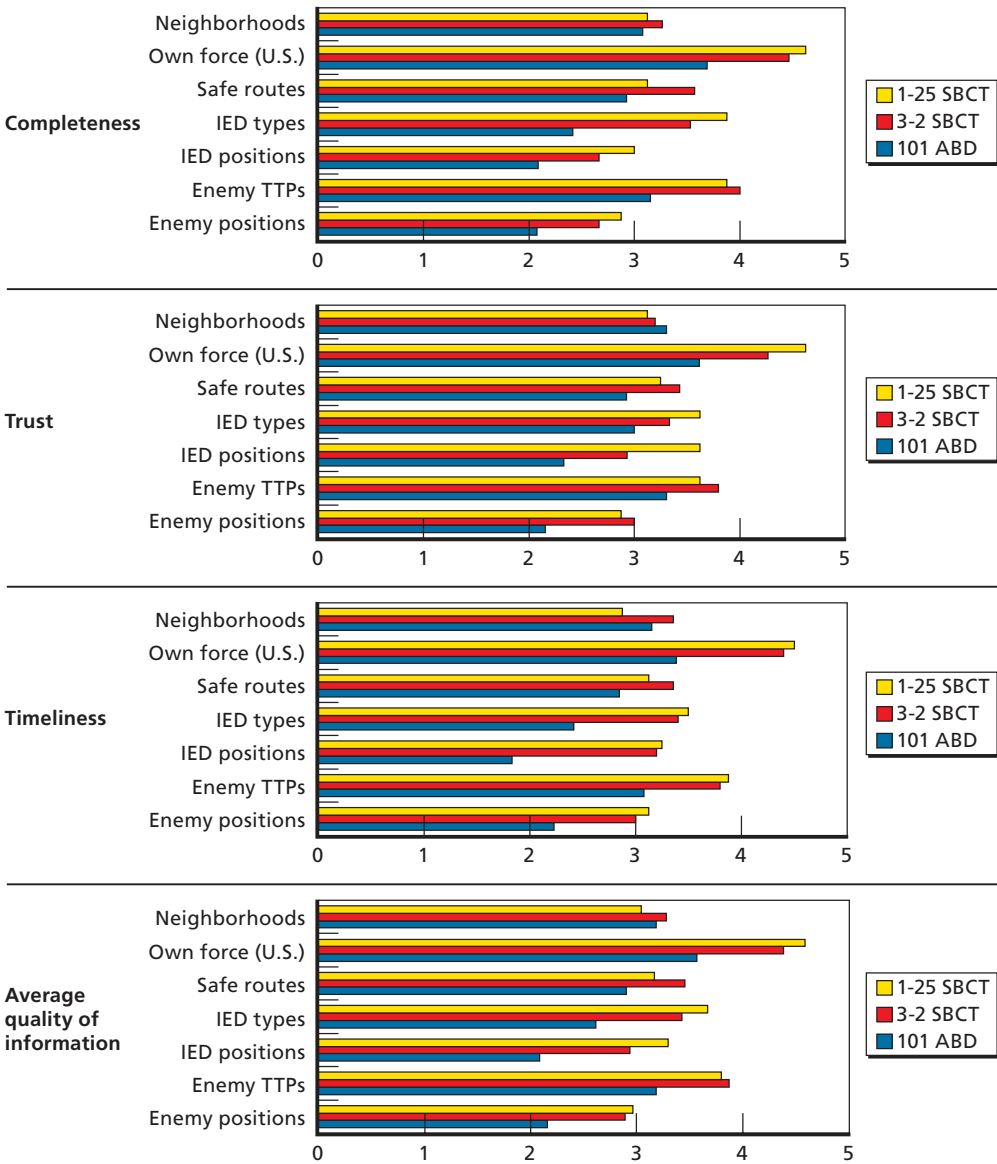

Figure 3.8
Quality of Information for Convoy Missions

Survey Question: We want to know about the quality of information that was available to you during the preparation stage of convoy missions. How would you rate the information you had about the following things in the left-hand column of the table?



The survey results suggest the following:

- All units had much higher quality of information for their own forces than for any other type of information. The SBCTs also had some of the greatest improvements in quality of information for own-force information, as well. These results suggest that the Army's networking systems do a better job with own-force information than with other types of information.
- Conversely, the 101st ABD reported a higher quality of information for knowledge of Iraqi leaders and security forces. These results are consistent with the 101st ABD having more MPs and chaplains interacting with their Iraqi counterparts on a regular basis. These results also suggest that the SBCTs' digitized systems and processes did not provide the same level of capability for sharing information about the local population as they did for own forces information.

These suggestions are reinforced in the next section, which looks at specific effects of networking systems on quality of information, as reported in lessons learned.

Specific Effects of Networking Systems on Quality of Information

This section describes the specific effects that the networking systems had on the quality of information, as reported by members of the units in lessons-learned documents and conferences.¹⁶ We discuss mainly the effects reported by the SBCTs; in addition to being the focus of the study, the SBCTs presented us with many more lessons-learned data than the 101st ABD. The effects in this section are predominantly from the 3/2 SBCT and 1/25 SBCT lessons-learned conferences, augmented by the SBCTs' lessons-learned reports.¹⁷

From analyzing the lessons-learned material, as well as from the survey results above, we discovered that the networking systems provide different capabilities with respect to different types of information. Thus, we discuss system effects with respect

¹⁶ The classified annexes to this monograph provide a detailed analysis of the various system contributions to the quality of information.

¹⁷ The bulk of the lessons learned in this section are from the 3/2 SBCT conference, because there were more sessions at the 3/2 SBCT conference devoted directly to networking issues. Comments from both 3/2 SBCT and 1/25 SBCT conference attendees were similar; we note significant remarks made during only one of the two SBCT conferences. See Center for Army Lessons Learned, 2003c, 2004b, 2005.

to four kinds of information: own force or “blue force” information; information on engagements and immediate threats (such as observed enemy activities and restricted areas); information on the enemy, or “red force” information; and information on the local population and Iraqi security forces, or “green force” information.

Blue Force Information

For the SBCTs, networking systems (notably FBCB2-EPLRS) provided a near-real-time, graphical picture of SBCT units in the battlespace. The only significant drawbacks to this picture had to do with completeness—friendly units not equipped with FBCB2-EPLRS generally were not on the picture and had to be tracked through voice communications. SBCT soldiers also requested higher update rates (to be able to direct vehicles more accurately) and that FBCB2 be able to display the positions of dismounted teams, particularly the positions of squad leaders.

In comparison, the 101st ABD only saw a near-real-time graphical picture of battalion commanders and above; commanders generally did not have a picture of where lower-level tactical units (platoon level and below) were. The unit did have satellite-based FBCB2-BFT tracking systems, which were commended for providing key situation awareness, but these were only present with aircraft, terminal attack controllers (TACs), and TOCs. Instead, the unit used its single UHF tactical satellite (TACSAT) channel as the backbone for interdivision communications and relied on FM voice at the tactical level.

Information on Engagements and Immediate Threats

For the SBCTs, the networking systems (notably FBCB2-EPLRS) provided a graphical picture of the engagement locations. FBCB2, Maneuver Control System–Light (MCS-L), and FalconView jointly provided graphical pictures of mission plans and fragmentary orders for many operations, as well. However, the reporting on engagements and threats was somewhat lacking: SBCT reporting largely used free-text messages and chat, which had to be manually interpreted to be added to the common operational picture (COP) and were sometimes not sent to the commanders and other SBCT soldiers needing to “overhear” them. Further, the lack of FBCB2 communications with units outside the SBCTs created gaps in sharing engagement and threat information among units.

In comparison, the 101st ABD relied almost exclusively on FM voice communications to exchange this information, with limited TACSAT radio for interdivision communications. FM voice communications were unreliable over the distances

involved and in an urban environment, which degraded the quality of information significantly.

Information on Red Forces and on the Local Population

The SBCTs largely lacked pictures of these types of information because FBCB2's structured reports were designed to transmit information about conventional military engagements. SBCT soldiers suggested that FBCB2 reports should address such events as demonstrations, suspicious activities, relations among suspects, patrol debriefings, and the results of meetings. Intelligence information largely existed as disjointed text and Microsoft Office products that provided slices of information—it was noted that ASAS was not structured to support stability operations. These products had to be manually routed and sometimes did not get to personnel who needed it. The 101st ABD's quality of information for red force information and information about local populations appears to have been similar.

General Systems Contributions

FBCB2 was praised for making significant contributions to the quality of information available, especially for blue force and engagement-related information. Both SBCT units and the 101st ABD reported that most of their planning and intelligence operations were conducted using Microsoft Office products and SIPRNET Web and email services. Most components of ABCS largely went unused; they were seen as either irrelevant to the situation at hand or unsuited to support stability operations.

Effect of Networking Systems on Quality of Collaboration

The same survey of 101st ABD and SBCT leaders also asked about the quality of coordination and collaboration they experienced in order to create a shared situation understanding. Soldiers were asked about collaboration within, above, and below their echelon; they were asked about collaboration with nonmilitary leaders as well. Figure 3.9 shows the survey question and the results.

Figure 3.9
Survey Results on Quality of Collaboration

Survey Question 3. We want to know about the quality of the interactions between soldiers, as well as with non-military leaders. We also want to know about the ability of these groups to collaborate and develop a shared understanding. How would you rate the effectiveness of coordination and collaboration between the groups listed in the left-hand column of the table to create a good, shared situational understanding?

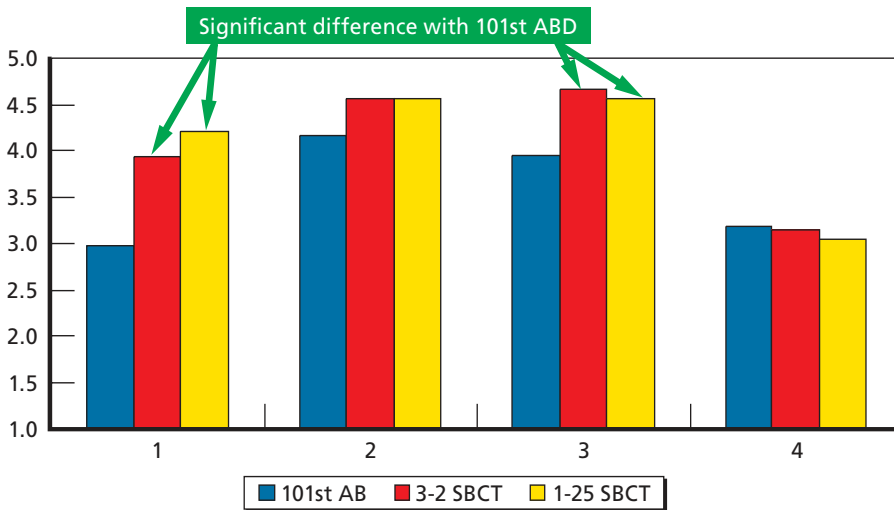

Key (x-axis)

- 1 = Coordination and collaboration with higher echelons
- 2 = Coordination and collaboration within your echelon
- 3 = Coordination and collaboration with lower echelons
- 4 = Coordination and collaboration with non-military echelons

Ratings (y-axis)

- 1 = Very poor (0–15% of required)
- 2 = Poor (16–39% of required)
- 3 = Fair (40–59% of required)
- 4 = Good (60–84% of required)
- 5 = Very good (85–100% of required)
- N/A = Did not coordinate with this group

RAND MG593-3.9

The figure shows that the SBCT assessments of the quality of collaboration were significantly higher for collaboration with higher and lower echelons than the 101st ABD assessments. Assessments for collaboration within echelons and with nonmilitary leaders were about the same. These results are consistent with lessons learned reported from the units.

For collaboration at a distance with lower echelons, as noted earlier, the 101st ABD was largely restricted to FM voice radio communications, which were subject to interruptions because of distance and interference. The commander of the 2nd Bri-

gade, 101st ABD, reported having spent a great deal of time finding officers, especially company commanders, and then traveling to meet with them in person. In contrast, the FBCB2-EPLRS network provided a much more detailed picture that showed where all the SBCTs' leaders were; it operated at longer distances and more robustly than FM communications. In addition, the FBCB2 software, combined with MCS-L and FalconView, provided a de facto collaboration suite for mission planning.

For collaboration with higher echelons, the 101st ABD was dependent on a limited number of UHF TACSAT terminals (using a single 25-KHz channel) and unreliable NTDR and MSE equipment for voice communications. In contrast, the SBCTs could rely on their broadband satellite network, IKSS, to exchange information. The 1/25 SBCT further improved its collaboration capabilities by adding fiber-optic links between some TOCs, increasing the bandwidth of IKSS by about 50 percent, and using voice-over-IP teleconferences regularly (including the commander's daily briefing).

In summary, the SBCTs had significantly greater access to remote communication and collaboration tools than the 101st ABD did. As a consequence, the 101st ABD was much more dependent on in-person meetings, which required significant advance notice and overhead to set up.

Quality of Shared Situation Awareness

In the NCO conceptual framework, quality of information, information sharing, and collaboration jointly influence shared situation awareness. Shared situation awareness is defined in the conceptual framework as “the capability to extract meaningful activities and patterns from the battlespace picture and to share this awareness across the network with appropriate participants.”¹⁸ Since situation awareness comprises the participants' cognitive processes, it must be measured indirectly and approximately. Perry, Signori, and Boon (2004) developed a quantitative model for shared situation awareness when there is a well-defined set of “features” to be “known”; their metrics track how well individuals in a group “realize” the features and how similar their “realizations” are to each other. These realizations strongly depend on the quality of the information about the features; how the information is presented; the education, training and experiences of the individuals; and the joint training and experiences of the group.

¹⁸ DoD, Office of Force Transformation, 2004, p. 145.

Gonzales et al. (2005b) developed a similar model for modeling situation awareness in air-to-air combat.

For stability operations in Iraq, we do not have a small, well-defined set of features to analyze. Instead, we make a quantitative assessment of the unit's shared situation awareness of various types of features—blue force, engagements/threats, red force, and local populations. We make the following assumptions, based on prior research:¹⁹

- Awareness levels are much higher if information arrives in a form that is easy to realize. Thus, geospatial displays usually lead to much higher levels of awareness than voice conversations. A person has to do significant mental work to generate a mental picture from voice conversations; with visual displays, the picture is much more immediately accessible. In addition, voice reports can have inaccuracies and ambiguities, lack critical information, or be degraded due to communications interference.
- Awareness degrades over time for two reasons. First, an individual's awareness will naturally diverge from a changing ground truth. Second, an individual's memory of details fades naturally. Information updates refresh awareness; memory aids (notably, being able to refer to a picture or transcript) reduce memory fading.
- Awareness depends strongly on having the skills, training and experiences needed to interpret and analyze incoming information.

Blue Force Situation Awareness

Both SBCT units had near-real-time visual displays of SBCT-unit positions and status. They also had access to instant messaging and email capabilities that provided transcripts of unit reports. These features led to a high level of situation awareness. SBCT shared situation awareness was degraded, however, by the fact that many coalition units outside the SBCT did not appear on the displays; the SBCT had to interpret radio communications with these units to gain awareness of them.

In comparison, the 101st ABD had access to similar near-real-time visual displays, but the data on these displays extended only to about the battalion level. Positions of company and below units generally were not displayed, and they could not be reached via instant messaging and e-mail. As a result, much of shared situation awareness about blue force positions had to be mentally generated from voice reports.

¹⁹ See Daniel Gonzales et al., *Network-Centric Operations Case Study: Air-to-Air Combat With and Without Link 16*, Santa Monica, Calif.: RAND, MG-268-OSD, 2005b; and Gonzales et al., 2005a.

All units reported being trained and having experience in interpreting incoming blue force reports, so skills, training, and experience did not dramatically impact shared situation awareness.

Engagement and Threat Situation Awareness

Both SBCT units had near-real-time visual displays of engagement and threat locations. The aforementioned reporting and messaging capabilities also provided transcripts of engagement and threat reports. However, as noted previously, some of these messages did not reach commanders who needed them, and there could be lengthy delays in translating text reports on engagements to geospatial pictures, both of which degraded awareness. In terms of preparing for engagements (mission planning), both SBCT units benefited from a high-bandwidth satellite network for exchanging presentations and other products graphically describing planned missions. The 1/25 SBCT further benefited from an established voice-over-IP system for collaborating about these plans.

In comparison, the 101st ABD had to rely on FM voice communications networks to monitor engagements and threats, which required manual interpretation of voice reports, leading to likely degradation of situation awareness. In terms of preparing for engagements, 101st ABD units, unless they had a SIPRNET connection, had to transfer PowerPoint presentations and similar documents manually. They also had to rely heavily on in-person meetings, greatly slowing the rate of updates.

All units reported being trained and having experience in interpreting mission plans and threat reporting, so skills, training, and experience did not dramatically affect shared situation awareness.

Red Force Situation Awareness and Local Population (Green) Situation Awareness

In contrast to blue force and engagement/threat situation awareness, all units—including the SBCTs—lacked common visual displays of information about red forces and the local population. Instead, this information and awareness was scattered throughout the units, with different organizations maintaining separate data repositories—and knowledge—about the enemy and of local populations. While the units did have visualizations, they were manually drawn on PowerPoint, Analyst's Notebook, geospatial display packages, or whiteboards. The update rate of red force and local population information is inherently constrained by intelligence reporting, but it was further degraded by delays in processing and visualizing the reports. More broadly, SBCT soldiers reported lacking a common approach (much less the tools) for representing a great

deal of information about red forces and the local population, such as social structures, relationships, intent, and resources. They did use red icons on the FBCB2 display to show suspected insurgent locations, but these were considered of limited value because the insurgents moved frequently and did not have identifying vehicles or positions. The result was significantly degraded situation awareness, with different groups possessing fragments of information about the enemy and the local population.

In addition, skills, training, and experiences played a significant role in further degrading situation awareness of red forces and local populations:

- Perhaps the biggest shortfall in being able to interpret information was that most soldiers could not write or speak Arabic. They could not directly talk to Iraqis or read Arabic newspapers, flyers, and graffiti. 3/2 SBCT and 1/25 SBCT soldiers noted a general shortage of linguists and translators, especially those capable of picking up nuance in conversations. They requested being provided with better language skills, at least to grasp basic Arabic commands.
- 3/2 SBCT leaders felt that their predeployment and relief-in-place training did not provide a sufficient understanding of the AOR to support effective stability operations immediately. 1/25 SBCT soldiers also noted that it took months to understand the population in the AOR and to begin to build a positive relationship with them.
- Soldiers from both the 3/2 SBCT and 1/25 SBCT reported that they were not initially trained on how to collect and process information effectively from various operations, which resulted in lost intelligence. Company-level leaders noted that soldiers needed additional training in how to process pocket litter (information found on individuals such as receipts, ticket stubs, and handwritten notes), electronic devices, and other materials obtained from suspects.
- 3/2 SBCT company-level leaders stated a desire for more training on negotiations and tactical questions. Part of the latter would include training on how to best interpret answers for writing actionable reports; there was discussion of significant amounts of “useless information” being reported (for example, “sheep herder can provide valuable information”).
- 3/2 SBCT soldiers requested additional cultural awareness training. They found it difficult to interpret personal cues to assess situations due to cultural differences. For example commanders found that it took a lot of trial and error to determine which contractors were reliable and which were not. Similarly, 3/2 SBCT leaders

noted that they did not interact with “white” agencies (Red Cross, Red Crescent, nongovernmental organizations) since “no one knew how to do it.”

- 3/2 SBCT leaders noted that MI units did not have the complete training needed to manipulate, correlate, and analyze raw intelligence data in stability operations, such as how to most effectively correlate and exploit the disjointed names, reports, and image databases available to them.

It is important to note that SBCT soldiers, especially from the 1/25 SBCT, reported that their skills improved substantially during the course of their deployment, and that their level of situation awareness of the enemy and of the population significantly improved. They reported greater use of network analysis tools (Analyst’s Notebook, CrimeLink), use of field systems (Stryker PDA used to store HVT photos, biometrics systems), and various techniques to improve relationships with the local population. For reference, Appendix B describes the tactics, techniques, and procedures used by the 1/25 SBCT.

Summary

Table 3.3 summarizes our assessment of the units’ shared situation awareness in stability operations.

It is useful to compare the SBCTs’ shared situation awareness in stability operations with their shared situation awareness in major combat operations. A RAND team examined the 3/2 SBCT’s performance during its certification exercise at the JRTC and calculated the completeness of its information position to be about 90 percent for blue force information and about 80 percent for red force information.²⁰ This compared favorably to a baseline infantry unit, which had only about 20 percent completeness for blue information and about 10 percent for red force information. While it is not possible to numerically calculate information positions for the SBCTs in stability operations, the information position for blue forces appears very similar to what the 3/2 SBCT had during its certification exercise (the “90% position”). However, the SBCTs’ red force information position appears far lower than what the 3/2 SBCT had during its certification exercise (the “80% position”).

²⁰ See Gonzales et al. 2005a.

Table 3.3
Summary of Units' Shared Situation Awareness

Situation Awareness Type	101st ABD	3/2 SBCT	1/25 SBCT
Blue force	High awareness from near-real-time displays for units at BN level and higher Limited awareness from intermittent voice reports for units below battalion	High awareness from near-real-time displays for most units in SBCT Limited awareness from intermittent voice reports for most units outside SBCT	Same as 3/2 SBCT
Engagements/ threats	Limited awareness of events from intermittent voice reports Mission planning hindered by need for in-person meetings	High awareness of locations from near-real-time displays for most units in SBCT Awareness of event details limited by free-text reporting Limited awareness of events from intermittent voice reports for most units outside SBCT Mission planning improved by document sharing over high-bandwidth SATCOM	Same as 3/2 SBCT, plus addition of voice-over-IP for mission planning
Red force and local population	Limited awareness due to disjointed information stores and displays Limited awareness due to lack of language skills, cultural awareness, and intelligence training specifically for stability operations	Same as 101st ABD	Same as 101st ABD, with greater mention of use of network analysis tools and techniques to improve relationships with the local population

During its certification exercise, the 3/2 SBCT used its greatly superior information position to dramatically improve its self-synchronization and tactics, which resulted in a factor-of-ten reduction in casualties over a baseline infantry unit, plus a nearly unprecedented victory over the JRTC's opposition force. In the next chapter, we evaluate the impact of the SBCTs' improved—but still incomplete—information position on the units' self-synchronization and tactics in stability operations.

Tactical Stability Missions, NCO-Enabled Processes, and Tactical Mission Effectiveness

The NCO Conceptual Framework, introduced in Chapter One, asserts that improved shared situation awareness and collaboration can lead to better self-synchronization of activities within units, better synchronization between units, and new processes that improve command decisionmaking, and that these in turn lead to greater tactical mission effectiveness. Results presented in the previous chapter disclosed that the Stryker brigades possessed better digital networking capabilities than the 101st ABD and that these capabilities frequently resulted in higher quality of information (QoI) and better collaboration. In this chapter, we first review the types of tactical missions that military units have been tasked to perform in stability operations in Iraq. Next, we examine the impact of QoI and collaboration on the ability of the military units to self-synchronize in high-stress combat situations, the innovative processes that the 3/2 and 1/25 SBCTs developed in stability operations, and these units' resulting mission effectiveness in a number of tactical missions important to stability operations.

Tactical Military Operations in Stability Operations

Military operations conducted by U.S. Army units in Iraq since May 2003 differ significantly from those conducted during the MCO phase of OIF. These differences result from the insurgency U.S. forces face in post-war Iraq and the need to conduct operations in close proximity to civilians. Whereas in MCO, adversaries would be expected in most scenarios to employ units in large formations with armored vehicles and heavy weapons, Iraqi insurgents are organized in small, distributed groups and use light weapons and IEDs. In a few Iraqi cities and towns they have controlled terrain

either because of a sympathetic populace or because they killed or drove out local leaders and local Iraqi security forces. In other areas, insurgents do not control territory at all. Instead they use hit-and-run sniper tactics, IEDs, suicide bombers, and ambushes to attack U.S. or Iraqi government security forces. Insurgents rarely mass their forces to hold territory when U.S. forces are present (the one exception was Fallujah).

To address the insurgency militarily, U.S. forces fight in a distributed manner in small company- or platoon-level formations. Instead of maneuver operations to take control of territory, tactical missions in stability operations more closely resemble law enforcement operations than those used in MCO. These can be classified as follows:

- Patrol operations
 - Mounted patrol
 - Dismounted patrol
 - Observation/sniping
 - Checkpoints (traffic control points [TCPs], entry/exit control points, etc.)
- Offensive operations
 - Cordon and search¹
 - Raids (refers to all targeted operations)²
- Support operations
 - Infrastructure protection (monitoring pipelines, arsenals, etc.)
 - Convoy operations
 - Base protection.

Cordon-and-search operations, or sweeps, are a blunt instrument. While they can lead to significant intelligence finds and weapons, they also disrupt entire neighborhoods and can generate significant animosity against coalition forces. Extensive sweeps through Mosul were conducted by the 3/2 SBCT in the spring of 2004. Sweeping operations were employed much less frequently by the 101st ABD and 1/25 SBCT in

¹ Here we are referring to *untargeted* cordon and search, in which units turn over entire neighborhoods. We consider “we cordoned and searched a house based on a specific tip” to be a targeted raid, not a cordon-and-search operation. The latter type of operation is typically carried out only when vague intelligence is available, such as “insurgents live in this neighborhood.” These types of operations are seen as having a strong negative value, as they build resentment with the population.

² Raids are seen as having high operational value, provided units can generate the intelligence needed to direct the operation.

Mosul. These types of operations were, however, employed extensively in Fallujah and Baghdad by other units.

The TTPs used by the Army units in Iraq have changed significantly in the stability phase of OIF (some of these are reviewed in Appendix B). These changes have required units to acquire a lot of “on the job training” in Iraq. This was especially true for the 101st ABD and the 3/2 SBCT. The 101st ABD had primarily trained for MCO-related missions prior to its deployment in OIF, and the 3/2 SBCT had trained in the continental United States (CONUS) on MCO scenarios prior to its deployment. The 1/25 SBCT was the first unit deployed to northern Iraq that had trained using a stability operations/counterinsurgency scenario. Even so, because of the highly adaptive nature of the adversary in Iraq, all units have encountered training challenges, which in turn has led to continuing changes in home-station training and training centers in CONUS.

The 101st ABD, 3/2 SBCT, and 1/25 SBCT conducted a number of significant operations during their rotations in Iraq. Some of the major operations conducted by these units are highlighted in Figure 4.1. As already discussed, the 3/2 SBCT played a major role in containing and quelling uprisings that occurred in central and southern Iraq in April 2004. The 1/25 SBCT played a significant role in the second battle of Fallujah and, through numerous operations, defeated a major insurgent offensive to capture the city of Mosul in 2004–2005.³ The 1/25 SBCT played a significant role in providing security and safety to Iraqi polling places during Iraqi national elections held in 2004 and 2005.

For the sake of brevity, we review only a few of these operations. The two we examine in detail are highlighted in yellow in Figure 4.1. Below, we describe, in generic terms, the characteristics of HVT and traffic control operations with and without advanced digital networking capabilities. These and the other operations described below provide good examples of how NCO capabilities can increase mission effectiveness.

³ LTG Thomas Metz, “Operation Iraqi Freedom II,” briefing as of August 1, 2005, not releasable to the general public.

Figure 4.1
Timeline for Major Operations in Northern Iraq

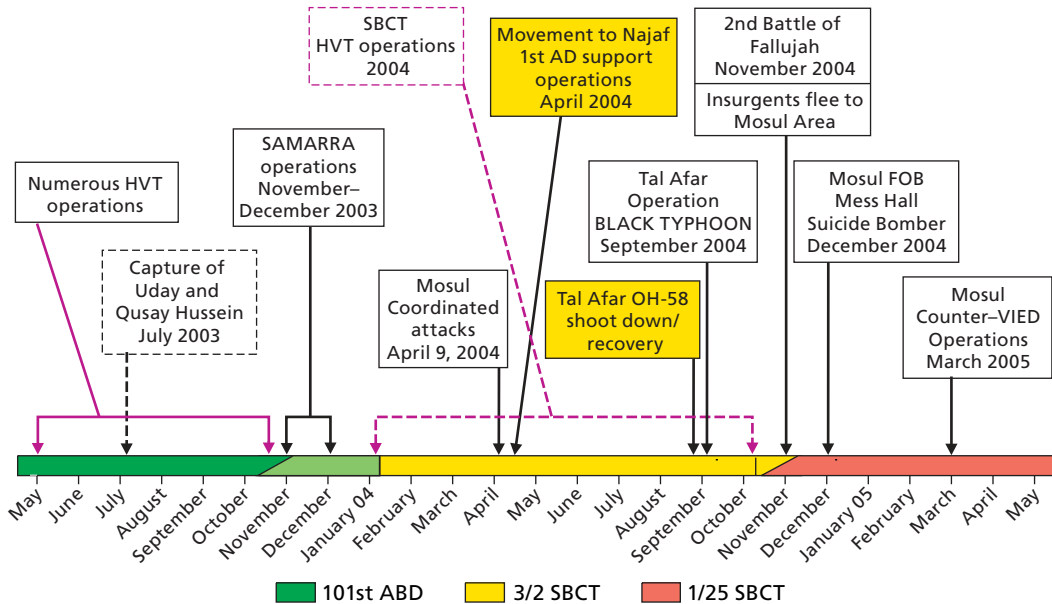

RAND MG593-4.1

NCO-Enabled Processes

From reviewing these operations, we did find evidence that the SBCTs used their NCO capabilities to execute tactical missions more effectively. We have identified NCO-enabled processes in three areas that improved the units' ability to self-synchronize their tactical operations:

- *Speed and agility of command.* We discuss improved processes for command and control in general, focusing on tactics the 1/25 SBCT frequently used against the insurgent offensive in Mosul and to capture HVTs. (The classified addendum provides examples of specific operations.)

- *Responsiveness of maneuver (C2 on the move).* We focus on the movement of a 3/2 SBCT battalion-sized task force to Najaf to support operations against the Sadr militia in the spring of 2004.
- *Use of airborne surveillance.* We discuss the 1/25 SBCT's ability to employ a variety of air surveillance platforms in conducting security and HVT operations.
- *Robustness in responding to enemy attacks.* We focus on the 3/2 SBCT's successful recovery of an OH-58 Kiowa Warrior helicopter in the face of a large insurgent attack. We compare what the 3/2 SBCT was able to accomplish with the Battle of Mogadishu, which also began with a helicopter shoot-down.

Speed and Agility of Command

During the March 2005 3/2 SBCT lessons-learned conference, SBCT members noted that their information and communications systems helped improve the speed of command and improved their agility.⁴ Several NCO capabilities contributed to this improvement.

First, FBCB2's capability to receive and display digital orders, HVT locations, and graphics on the move was cited as significantly improving the SBCT's OPTEMPO and agility. Digital orders, precise target coordinates (if available), and graphics reduced the time required for planning and briefing cycles, improving OPTEMPO. Further, the ability to receive this information in the field and on the move further accelerated the dissemination of intelligence and command information.

Second, FBCB2 provided units with geospatial maps and overlays. SBCT leaders noted being able to provide a wide range of useful overlays for FBCB2's maps, including movement routes, boundaries and control measures, key infrastructure locations, and areas of insurgent activity.

Third, digitization at platoon and company level improved SBCT units' abilities to self-synchronize and synchronize with other units on the move based on shared friendly unit information. The graphic displays of FBCB2-equipped vehicle positions and information, along with voice communications and FBCB2 messages, provided key information to control current operations.

⁴ U.S. Army Infantry School, 3/2 SBCT OIF Lessons Learned Conference, Fort Lewis, Wash., March 23–24, 2005.

The combination of shared tactical graphics, precise geospatial information, precise target locations, and continuous friendly unit locations allowed commanders to retask units as needed. At the 3/2 SBCT lessons-learned conference, leaders frequently cited examples of changing a mission in the field and on the move to respond to an IED, assist a unit in an engagement, secure a mortar firing point, or respond to perishable actionable intelligence on the location of an HVT.

SBCT units were able to use the same capabilities to “swarm,” that is, to have several vehicles or units converge on a specific location with minimal advance notice or planning. SBCT commanders presented examples in which, after planning a raid over FBCB2, small groups of Stryker vehicles were sent out “on patrol.” At the specified time, the Stryker units would converge at designated points and conduct the raid. As a result, the SBCT units were able to surprise their adversaries because insurgent “gate-watchers” monitoring Stryker units leaving their forward operating base would just see units leaving on normal patrols.

Figure 4.2 is a notional comparison of an SBCT’s speed of command and agility and that of a conventional analog-equipped light infantry ground unit. The conventional unit’s operation begins with a lengthy planning and briefing cycle, followed by a precise execution of the preplanned operation. The unit is unable to respond effectively to many types of significant events that require a mission change. Further, since the conventional unit leaves to conduct the operation in formation, the opposing force can detect much of the operation in advance. Conversely, the SBCT has a much shorter

Figure 4.2
An Order-of-Magnitude Increase in Speed and Agility of Command

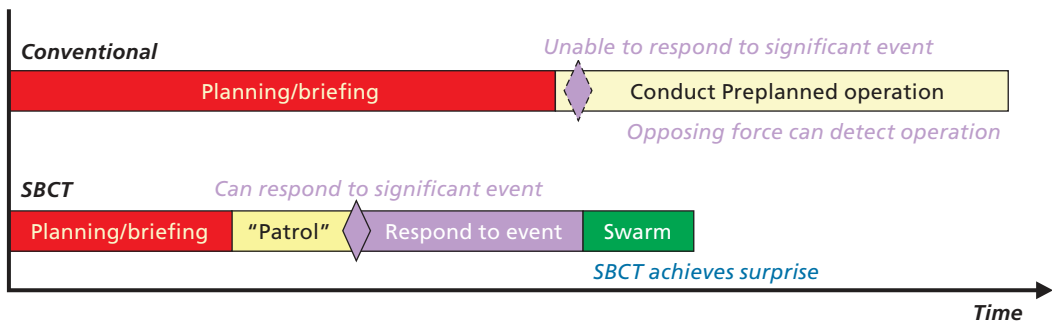

planning and briefing cycle, followed by the departure of small, innocuous groups of Stryker vehicles “on patrol.” When events occur that require changes in the plan, the Stryker commanders update the plan over FBCB2 while on the move to target location. Finally, the SBCT units swarm at the appropriate time, achieving surprise. The entire operations cycle is significantly shorter than that of a conventional ground unit.

The difference between the decisionmaking speed or speed of command demonstrated by the SBCT and analog-equipped conventional units is most striking in HVT cordon-and-search operations. Some specific examples of these operations for both types of units are discussed in the classified addendum to this report. Here we only wish to point out that, for a typical HVT operation by a light infantry brigade using analog communications, the time required to plan, brief, and conduct the operation is typically eight to twelve hours. The 101st ABD, for example, reported that this timeframe was normal for planning its operations; for routine operations, it operated on 24-hour daily planning and execution cycle. These longer timeframes were required by its analog communications—as noted in the previous chapter, the 101st ABD commanders had to spend time to find their officers, and they depended heavily on in-person meetings to do mission planning. In contrast, the SBCT can conduct such operations with no prior notice or planning in the field and while on the move in 15 to 30 minutes. This represents an order-of-magnitude decrease in the time required to plan and execute these operations.

The 1/25 SBCT further developed the 3/2 SBCT’s NCO-enabled tactics, emphasizing distributed decisionmaking and self-synchronization in addition to speed of command. Appendix B describes the 1/25 SBCT’s TTPs in detail. In brief, rather than focusing on conventional preplanned operations, the 1/25 SBCT gave its units down to the lowest tactical level their own “areas of responsibility,” with platoons, squads, and individuals regularly covering particular streets, thus providing them with a great deal of information and experience about those neighborhoods. Unit patrols were flexible, multi-mode operations, combining mounted patrol, dismounted patrol, and observation segments. Soldiers also reported incorporating random checkpoints as part of their patrols; these were considered highly effective because the insurgents were confused about when, where, and why checkpoints were appearing, significantly limiting their movements. The FBCB2-EPLRS network provided the communications and C2 backbone, allowing these distributed operations to run effectively.

The 1/25 SBCT units were also on call to respond to situations in their local area. Soldiers noted being frequently redirected to mount an immediate raid in response to an incoming tip (from HUMINT, visual contact, signals intelligence hit, etc.) with the

fragmentary orders, information, and instructions provided both over the radio and over FBCB2 (which showed the target location). The ability to respond immediately to an incoming tip was regarded as critical. Soldiers reported they had to respond to a tip on an HVT's location within 30–45 minutes to have any chance of succeeding. Being in the local area and able to respond dynamically put them inside this window, whereas conventional targeting and planning followed by mounting a QRF did not. This ability was reported by 1/25 soldiers as instrumental in helping the 1/25 capture or kill the top two layers of Al Qaeda leadership in the Mosul area by the end of its rotation—leaders who generally changed position very frequently. The classified addendum presents some specific examples of successful and unsuccessful efforts to capture HVTs based on time-critical intelligence information.

Responsive Maneuver

In April 2004, the 3/2 SBCT was called on to send a battalion-sized task force, predominantly members of the 5th Battalion, 20th Infantry Regiment (5-20), to Najaf in support of 1st Armored Division operations against the Mahdi Army. The SBCT was able to send the resulting task force 600 miles in two days, despite having to fight several engagements en route, and despite having to make major route adjustments in response to insurgent actions. Figure 4.3 documents the task force's movement to Najaf based on material in the 3/2 Stryker After Action Report (AAR).

The task force began leaving forward operating base (FOB) Q-WEST on April 11 at 0300; by 1830, it had reached FOB Warhorse. After engaging and destroying a bicycle-borne IED and resting for several hours, the task force left FOB Warhorse starting at midnight on April 12.

The task force then split into two groups, with one group taking a western path around and through Baghdad. The other group took an eastern route and was attacked by anti-Iraqi forces at 0200 with IEDs, RPGs, and heavy automatic weapons near the bridge over the Tigris River the group planned to use. The task force group returned fire and secured the bridge; however, the AIF had made the bridge impassable before the group's arrival. Thus, the task force rerouted the eastern group to secure the bridge at Al Kut. By 1800, the task force group had secured and crossed the bridge, reached Combat Support Company (CSC) Scania, and refueled. The two task force groups then rejoined and began moving west.

Figure 4.3
SBCT Task Force’s Movement to Najaf

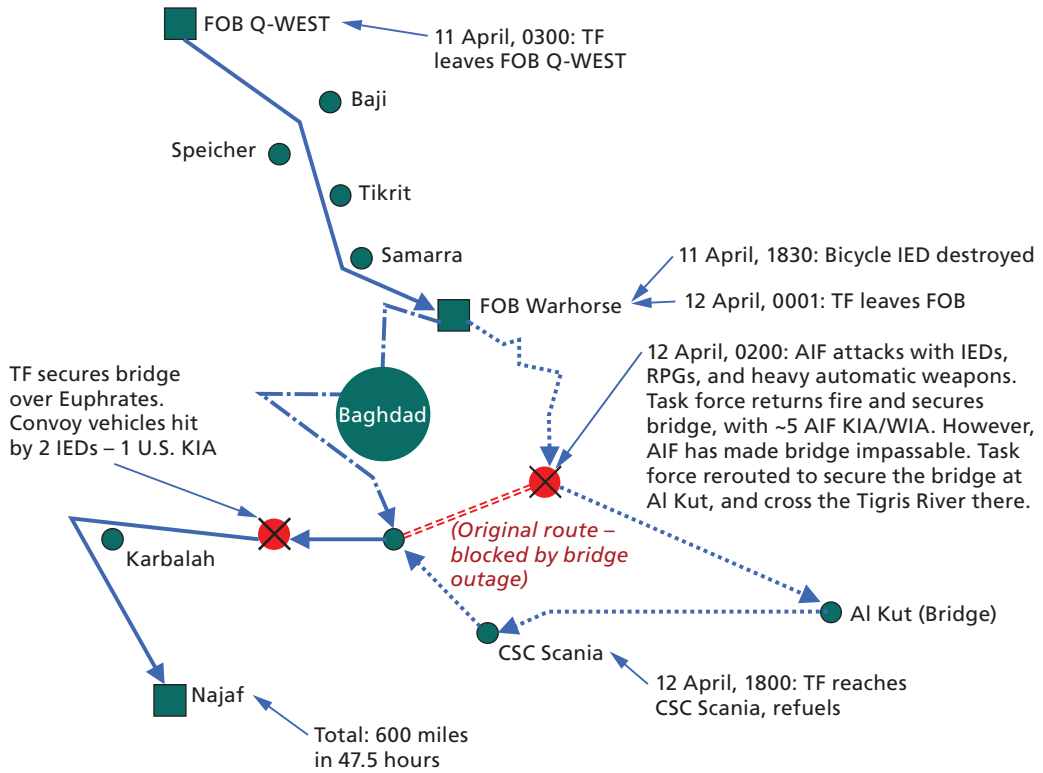

NOTE: Figure not drawn to scale.

RAND MG593-4.3

The task force then secured a bridge over the Euphrates and faced its final engagement, in which convoy vehicles were hit by two IEDs—with one U.S. soldier killed in action (KIA). The task force reached Najaf shortly thereafter, having traveled over 600 miles in under 48 hours.

The movement of mechanized infantry units so far in such a short period time—especially in the face of enemy attacks and having to reroute forces en route—was unprecedented. A key enabler of the task force’s success was that they were able to *plan and adapt on the move*, using a combination of C2 and communications systems.

From a materiel perspective, the C2 and communications systems provided necessary support. The task force capitalized on FBCB2’s map databases to travel lengthy

distances—and reroute—beyond what is typically possible with paper maps. Despite the fact that the vehicles were frequently out of sight of each other and out of FM radio contact, the task force units were able to use a number of systems to maintain contact and thus maintain friendly force awareness and communications, and hence self-synchronization and dynamic synchronization. The Stryker AAR notes that the systems used included TACSAT, high frequency radio, FBCB2, and BFT, and that “these systems work, learn them and manipulate them.” Further, the 5-20 battalion commander had satellite on-the-move communications (PSC Spitfire), which allowed him to exercise C2 on the move. In addition, the SBCT commander and higher echelons used the same systems to keep track of the task force’s progress as well as their engagement reports, allowing them to retask the task force as needed.

From a nonmateriel perspective, the SBCT appears to have used enhanced TTPs to conduct the maneuver. The Stryker AAR noted that “[maneuver is] no longer just a road march but a series of bounds to secure key terrain for the crossing of the main body”; i.e., the force used ISR assets to look first and reroute on the fly if necessary. This differs from the conventional approach of keeping the forces moving along a pre-planned route.

The specific military value of this operation was that it provided the forces that MNC-I needed to secure major supply routes from Najaf to Baghdad.⁵ The general military value of the SBCTs’ responsive maneuver capability is that it allows commanders to maneuver medium ground forces hundreds of miles as needed in just a few days, without having to use airlift.

Networking with Aerial Support and Surveillance Assets

The 1/25 SBCT used manned fixed-wing and rotary-wing aircraft, along with UAVs, in both traditional and nontraditional roles. U.S. Air Force fixed-wing aircraft were used for close air support (CAS) throughout the brigade’s entire deployment. Early in the deployment, CAS was used heavily in its traditionally lethal role to destroy targets. Later in the deployment, the main use of CAS was providing nonlethal effects. The brigade used CAS for observation and surveillance of named areas of interest (NAIs) as well as a show of force. The brigade found that the use of CAS to detect or influence targets using nonlethal means was effective.

⁵ Nicholas Riccardi and Edmund Sanders, “Insurgents Rule the Roads,” *Los Angeles Times*, April 19, 2004.

The Rover III, discussed earlier, received high marks from officers and soldiers of 1/25 SBCT. The Rover III helped the brigade employ CAS and conduct surveillance (to include tracking HVT vehicles) and route reconnaissance. Indeed, the 1/25 SBCT noted that the use of Rover III was instrumental in capturing several HVTs. The Rover III was also compatible with Predator; when the Predator was flown during 1/25 SBCT's rotation, soldiers were able to download its ISR data with the Rover III and use the data for mission planning.

1/25 SBCT soldiers did have difficulties with describing the video feeds from the battalion tactical operation centers to soldiers on the ground via voice radios. In most cases, real-time UAV video feeds were not available to the soldiers on the ground.

Social networking across ground-air boundaries was as important to airborne surveillance and support as technology. Thus, the aircraft of choice to provide security and surveillance were Army helicopters. Soldiers preferred the OH-58 Kiowa Warrior over a UAV for all missions. Specifically, Air Weapon Teams (AWTs) and "Pink Teams" (an Apache accompanied by a Kiowa Warrior) proved to be combat multipliers. The AWT coverage for convoys was initially hampered by the SBCT not having had the opportunity to train with the AWTs before deployment but rapidly became critical for convoy protection. Pink Teams provided the best area surveillance and firepower if needed. The soldiers were able to communicate directly with the pilots and receive observation updates. Pink Teams working along with the Strykers were successful in capturing HVTs during both cordon-and-search and TCP operations. The Pink Team would follow a suspected HVT's vehicle and radio the vehicle's movements, while Stryker units would maneuver to intercept. The pilots gave additional confidence to the soldiers on the ground, who knew that help would be there when they needed it. The pilots also regularly put themselves in harm's way to protect the soldiers on the ground.

Robustness to Enemy Attack

Below, we compare two battles in which U.S. forces faced the downing of U.S. military helicopters and an ambush by large numbers of insurgents. For the 3/2 SBCT, such a battle occurred on September 4, 2004, when the 5-20 Infantry Regiment responded to the shoot-down of an OH-58 Kiowa Warrior helicopter during HVT operations in the city of Tal Afar. We compare this battle with the well-known Battle of Mogadishu. We discuss the Battle of Mogadishu first; details are drawn from four principal sources:

Black Hawk Down,⁶ a report to Congress,⁷ a classified lessons-learned study,⁸ and a congressional report.⁹ Note that our purpose is not to compare unit mission effectiveness, because circumstances were significantly different in each case. Rather, it is to assess and compare the information-sharing capabilities of the two different military units and see how these capabilities or lack thereof may impact mission effectiveness. As described below, the operational context, the strength of opposing forces, and coalition force composition in each case were significantly different. Nevertheless, lessons can be drawn from these events concerning the importance of situation awareness information and C2 capabilities in urban military operations.

Battle of Mogadishu

The Battle of Mogadishu took place on October 3–4, 1993. The objective of the operation, “Gothic Serpent,” was to capture senior figures in Mohammed Farrah Aidid’s Hadr Gidr clan, Omar Salad and Mohammed Hassan Awale, while they were attending a meeting near the Olympic Hotel in Aidid’s “Black Sea” stronghold in Mogadishu.¹⁰ The force comprised 160 soldiers, 19 aircraft, and 12 ground vehicles:¹¹

- An air assault force delivered by four MH-6 Little Bird helicopters and two MH-60 Black Hawk helicopters (one carrying the mission commander)
- A Ranger blocking force delivered by four MH-60 Black Hawk helicopters
- Four AH-6 gunship helicopters equipped with miniguns and rockets to provide CAS
- One MH-60 placed on stand-by with combat search and rescue (CSAR) personnel and equipment

⁶ Mark Bowden, *Black Hawk Down: A Story of Modern War*, Berkeley, Calif.: Atlantic Monthly Press, 1999.

⁷ Ronald E. Dolan, *Somalia/Operation GOTHIC SERPENT, A History of the 160th Special Operations Aviation Regiment (Airborne)*, Prepared for the Library of Congress Under an Interagency Agreement with the 160th Special Operations Aviation Regiment (Airborne), October 2001.

⁸ USSOCOM, “Task Force Ranger Operations in Somalia,” History and Research Office (MacDill Air Force Base, Fla., June 2001), not available to the general public.

⁹ Senator John Warner and Senator Carl Levin, “Review of the Circumstances Surrounding the Ranger Raid on October 3–4, 1993 in Mogadishu, Somalia,” Memorandum for Senator Thurmond and Senator Nunn, Washington, D.C.: United States Senate Committee on Armed Services, September 29, 1995.

¹⁰ Warner and Levin, 1995.

¹¹ USSOCOM, 2001; Bowden, 1999.

- A ground reaction force (GRF) equipped with nine wide-body high mobility multipurpose wheeled vehicles (HMMWVs) and three five-ton trucks.
- An air observation force of three surveillance helicopters: one OH-58, and two specially equipped OH-6s; and one Navy P3 Orion surveillance aircraft.

Figure 4.4 shows a general map of Mogadishu and the initial position of U.S. assault forces.

Once the force was in place, the assault force would storm the target building while the Rangers would secure the perimeter. Meanwhile, the ground convoy would move into position one block south of the target, move to the front of the target building to load the prisoners and assault force, and then return by road to the base (the Mogadishu airport).

The operation started with the assault and blocking forces “fast roping” from their helicopters into the target area. While the targeted clan leaders were captured without incident, the forces on the ground came under attack almost immediately. The circling AH-6s and Black Hawks provided CAS to forces on the ground. Two Black Hawks were shot down in the city during the operation. A pilot was severely injured in the second crash. He was taken captive by Somali warlords and was held for eleven days until he was released to the United States.¹²

The character of the operation changed significantly after the two helicopters (Black Hawks #61 and #64) were shot down. The forces on the ground, including the GRF, were diverted to reach and secure the helicopter crash sites and rescue the survivors. The entire operation was designed to last about an hour, but it was not completed for over fifteen hours because of difficulty in rescuing the survivors and extracting the forces and captured prisoners. The ensuing battle resulted in a large number of U.S. and Somali casualties. Five Black Hawk helicopters were lost or severely damaged and a large number of ground vehicles were damaged beyond repair. A number of factors have been cited as causes for the unfortunate outcome of this operation: lack of an armored U.S. quick reaction force, repeated use of similar tactics by Ranger and assault forces in Somalia, lack of unified C2, communications

¹² USSOCOM, 2001.

Figure 4.4
Map of Mogadishu and Initial Position of Assault Forces



RAND MG593-4.4

interoperability problems, and use of heterogeneous force with different equipment and experience.¹³

The focus of our analysis is on the use of networking capabilities and information sharing. An examination of this operation reveals that C2 and networking problems contributed significantly to the costs incurred during the Battle of Mogadishu. A serious problem was the lack of an interoperable communications systems and digital communications between the different elements of the ground force and between airborne and ground force elements. Units on the ground were not equipped with Global Positioning System (GPS) receivers and had only paper maps; there were no FBCB2-like systems displaying their location and other friendly locations. Further, ground forces communicated with voice-only radio networks, which had two key problems. First, there was no interoperable ground force-wide network; different units were on different voice subnets because of radio interoperability problems. In particular, the ground convoy and different elements of the ground force were all on separate subnets; the only common link was “Command Net,” which linked the assault force, blocking force, and GRF commanders via the C2 Black Hawk, which carried the task force commander. Second, some of the subnets used by the ground forces and the fire support coordination net became saturated during the most intense phases of the operation because all information had to be communicated by voice and because there were so many participants on these subnets. The lack of a common network for communications and a lack of digital information on blue force positions led to a number of communications breakdowns and significant time delays in communicating navigation, status, and position information—all of which adversely affected the battle. Figure 4.5 shows a timeline of the Battle of Mogadishu; communications problems are highlighted in yellow and are described in more detail below.

Immediately after the assault force detained the prisoners, they waited inside for the ground convoy to signal when it was time to load the prisoners while the ground convoy waited a few feet away for the assault force to come out. The two units could not communicate directly with one another, which caused a delay in the operation. The delay proved costly when a five-ton truck was disabled; it also caused the Black Hawk helicopters to be vulnerable while providing support during a longer-than-expected period.

¹³ USSOCOM, 2001; Warner and Levin, 1995; Bowden, 1999.

Figure 4.5
Timeline of the Battle of Mogadishu

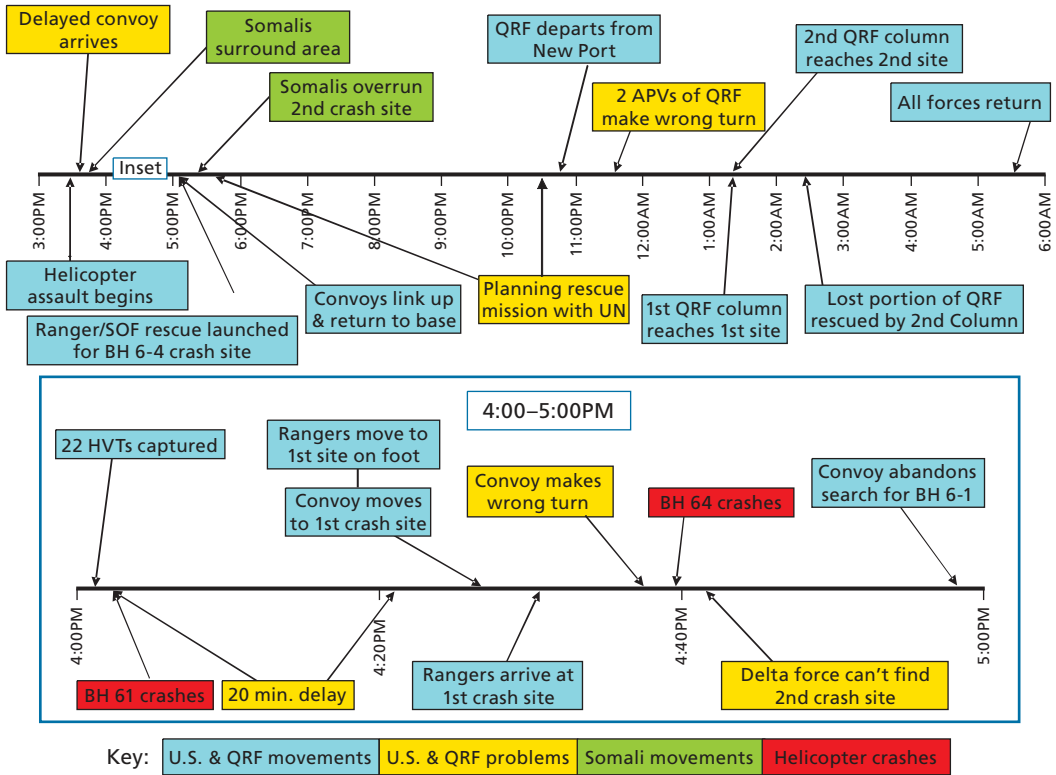

RAND MG593-4.5

Assault forces saw the first helicopter get hit and where it crashed; however, they had no ability to directly communicate this information to the GRF commander downstairs. While in motion, Rangers from the blocking force were picked up by the GRF and loaded into the back of one of the five-ton trucks. These Rangers, who were now a part of the GRF, actually had seen the first crash site twice, but because they lacked situation awareness and communications, they did not know that it was their destination and could not communicate with the GRF commander that they had seen the crash site from their truck.

I remember seeing the crash wedged between buildings as we passed. There were at least a team of two soldiers. I didn't know we were trying to get to it, plus I had seen the guys on the street so I thought the area had been secured.¹⁴

The P3 Orion could see both the GRF and the crash site. However, the lack of a direct communications channel between the surveillance aircraft and the GRF commander meant that route directions were relayed from the P3 Orion to the GRF via the C2 Black Hawk. By the time a direction was relayed to the GRF, it was no longer valid, and by the time corrected directions were relayed, they were no longer valid. In addition, because the directions were time delayed, the GRF frequently had to stop to verify that the instructions it had received were correct.

The C2 bird was doing the best it could to tell us how many “rights” and “lefts” to take, but a “right” and a “left” here—that is difficult when you are in a vehicle on the ground and you are driving pretty fast because people are shooting at you. Every alleyway we went by had someone shooting something. . . .¹⁵

The result was to add to the delays experienced by the GRF and to increase its vulnerability.

The commanders in the C2 Black Hawk and the lead vehicle in the GRF each had numerous communications options, and they also had to act as a relay between multiple voice channels, which resulted in errors. For example, the GRF asked the MH-6 helicopters to direct them to the crash site. However, the GRF did not specify which crash site because the commander thought it was understood. Instead, at one time, they were given directions to the second crash site.

Command Net, which linked ground commanders to the C2 helicopter and to the Joint Operations Center (JOC), had become jammed right after the first Black Hawk crashed, due to the volume of voice reports. As a result, commanders were unable to issue orders to respond to the crash until after individual units had already made unilateral decisions.

Soon after the two helicopter crashes, the AH-6s were not allowed to engage targets until later in the afternoon, because commanders in the air were uncertain as to the location of all friendly forces. Later, the fire support coordination net, which con-

¹⁴ USSOCOM, 2001, p. 134.

¹⁵ USSOCOM, 2001, p. 135.

nected commanders on the ground with the C2 Black Hawk (which also housed the aviation force commander) and the four AH-6 gunships, also became jammed at times during the operation. During one period, the AH-6s were providing CAS at two crash sites, at other locations on the ground, and to two convoys—the GRF and the initial QRF—resulting in a very complex and dynamic tactical situation that had to be managed entirely with voice communications.

After an initial QRF was launched from the Ranger base at the airport, the original GRF and the QRF were both guided by the same C2 Black Hawk over the same voice network. This led to the GRF at times following the directions for the emergency convoy and vice versa.

Under intense fire and with casualties mounting, the GRF commander knew he had to break off the search for the crash site. The GRF quit the search for the first crash site by 5:00 p.m. because it had suffered numerous casualties and was low on ammunition. The first QRF came close to the second crash site but was unable to reach it because of strategically placed roadblocks. Somali militia overran the second crash site; the pilot was taken hostage and two U.S. soldiers were killed.¹⁶

The JOC then decided that a larger QRF with armor would need to be assembled to reach the soldiers remaining at the first crash site. Assembling the QRF took over four and one-half hours; part of the delay was caused by the need to create a uniform communications system with U.S. radios and call signs to prevent fratricide, to incorporate soldiers and vehicles from other nations into the QRF, and to reach agreement on common tactics. The QRF included a mixture of U.S., Malaysian, and Pakistani forces, with about 60 vehicles including tanks and armored personnel vehicles (APVs).¹⁷ Because of disagreements between U.S. and coalition forces in the QRF, the QRF columns took almost an additional two hours to reach the crash sites; one contributing problem was two APVs making a wrong turn.

In summary, the various units of the assault, blocking, GRF, and CAS forces frequently lacked shared situation awareness and understanding—of where they were with respect to each other, of where the crash sites were, and even of commanders' intent. While commanders in the C2 Black Hawk and at the JOC were able to obtain high-quality situation awareness from the ISR helicopters circling overhead, only one video stream could be transmitted at once. Multiple elements of the Ranger units, assault forces, and ground convoys were separately reporting and experiencing their own parts

¹⁶ USSOCOM, 2001.

¹⁷ USSOCOM, 2001.

of the battle. This lack of situation understanding led to significant delays (in loading the prisoners, in providing CAS, and in directing rescue forces to the right place). It also diminished the ability to synchronize and self-synchronize, as the various units acted independently (some of these independent actions also resulted from the lack of a single commander on the ground). These in turn led to problems responding to enemy attacks—and to U.S. and coalition casualties. In total, in the Battle of Mogadishu the U.S. suffered 16 KIA and 83 QRF personnel wounded in action (WIA); Malaysia suffered two KIA and seven WIA; and Pakistan suffered two WIA (see Table 4.1).

3/2 SBCT Downed Helicopter Rescue at Tal Afar

The Iraqi city Tal Afar lies on an important trading route to Syria. In 2004, the city had received only occasional visits from elements of the 3/2 SBCT. Intelligence on insurgent or foreign fighter activity in the city was sparse. Press reports later indicated a growing foreign jihadist presence in Tal Afar, including terrorist cells loyal to Abu Al Zarqawi. Control of Tal Afar was alleged to enable Al Qaeda in Iraq to funnel foreign fighters and money into Iraq.¹⁸

On September 4, 2004, the second day of Operation Assyrian Drifter, Task Force 5-20 maneuvered into Tal Afar. During this operation, Task Force 5-20, composed

Table 4.1
Battle of Mogadishu Total Mission Casualties

	Dead	Wounded
United States	16	83
Malaysia	2	7
Pakistan	0	2
Total (coalition)	18	92
Total (Somalia)	354	764

SOURCE: USSOCOM, 2001; Bowden, 1999.

¹⁸ Public Broadcasting Service, “Inside the Iraqi Insurgency,” *Documentary, Frontline News Magazine*, February 21, 2006.

of elements of the 3/2 SBCT, faced an incident similar in character to the start of the Battle of Mogadishu.¹⁹

That day, the task force was to conduct three simultaneous HVT cordon-and-search operations. The task force was composed of one Stryker company, one Stryker scout platoon, and an ING company. While Stryker elements in the operation employed Stryker armored vehicles, the ING company was equipped with pickup trucks and open jeeps, with many soldiers riding in the open in the back of the pickups.

The operation initially proceeded according to plan, although the units fell behind schedule because of the slow speed of the ING vehicles. Detainees were captured at each objective. At 8:35 a.m., elements of Company B at Objective Jonah were attacked by RPG fire. Two ING soldiers were seriously wounded and required medical air evacuation. The company commander set up a perimeter defense at Objective Jonah in response to the insurgent attacks.

Simultaneous with the medical air evacuation at Objective Jonah, a separate element of Task Force 5-20, a Stryker brigade scout platoon, was completing the third HVT operation at Objective Gilgamesh elsewhere in the city. The platoon received air surveillance support from two OH-58 Kiowa Warrior helicopters.

At 8:50 a.m., one of the OH-58s was shot down after being hit by an RPG. Figure 4.6 shows the timeline of the ensuing three-hour engagement to recover the pilots and the OH-58 helicopter.

The Kiowa Warrior was equipped with the FBCB2-BFT system, which continued to report the helicopter's position after the crash. The 5-20 commander both heard about the downed aircraft over the radio network and could see its location on his FBCB2-BFT display, less than 1,000 m from his location. He could also see the location of the Stryker scout platoon on FBCB2. Almost immediately, this same information was available to all FBCB2-equipped Stryker vehicles of Task Force 5-20. The 5-20 commander was in radio contact with the OH-58 pilots by 8:57 a.m. and told them to stay put, since he knew they were in range of friendly forces. Within five minutes, vehicles from the scout platoon were on the scene of the crash site, secured it, and moved the pilots to a Stryker medical evacuation vehicle.

¹⁹ COL Stephen J. Townsend, "Observations on the Battle of Tall Afar, Iraq, 4 September, 2004, Operation Assyrian Drifter, Day 2," September 24, 2004; Matthew Cox, "They Weren't Going to Get This Bird," *Army Times*, November 22, 2004; Bill Hutchins, "Helicopter Heroes," *The News Tribune*, February 12, 2005.

Figure 4.6
Timeline for the Tal Afar Incident

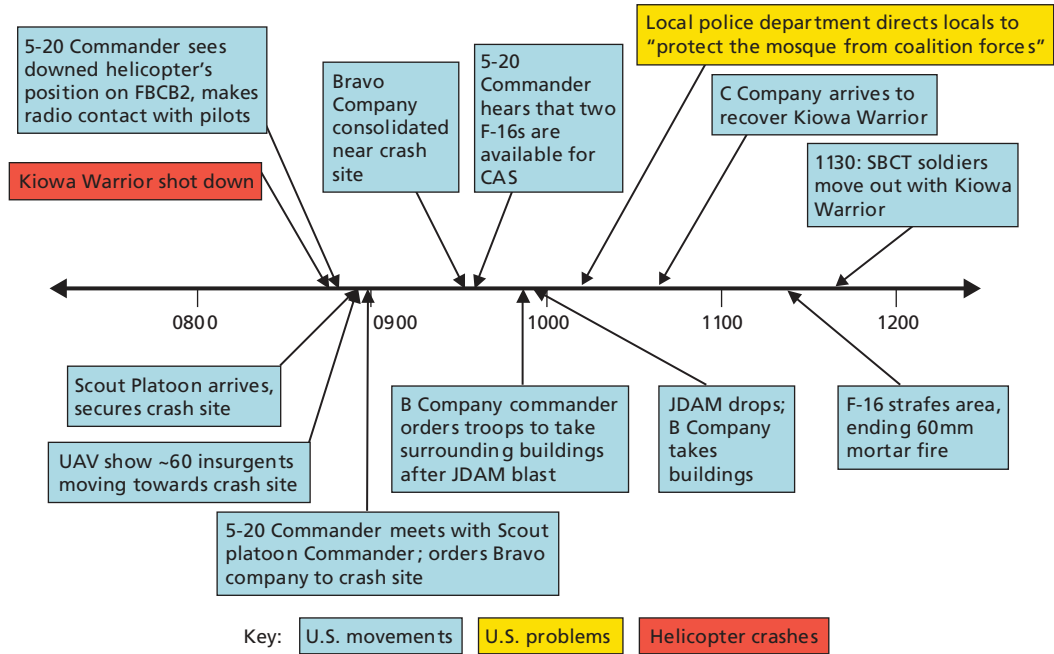

SOURCE: *Army Times*.

RAND MG593-4.6

A few minutes later, UAV surveillance showed about 60 more insurgents moving toward the crash site, and over the next 20 minutes the scout platoon would engage in intense fighting with coordinated insurgents armed with RPGs, machine guns, and small arms. Under increasing pressure at the crash site, the scouts requested reinforcements.

In response, at 9:00 a.m., the 5-20 commander ordered Bravo Company to reinforce the west side of the crash site. As the company headed south through the city toward the site, it came under fire. Because of the small roads and alleyways, there was no direct route to the site. The column had to head south of the crash site, move east on another road, and then north in a fish-hook-shaped maneuver. As the column got closer to the site, the intensity of fire increased dramatically. Insurgents had occupied nearby buildings and were raining fire down on the column of Bravo Company and ING vehicles.

While on the move toward the crash site, the scout platoon radioed updates and requests:

- They were under heavy fire and were experiencing severe pressure on their flanks.
- They urgently requested permission to use CAS to suppress the enemy assault.
- If unable to use CAS, they would likely have to destroy the aircraft and/or abandon the site.²⁰

Updates also came in from elements of Bravo Company:

- One of Bravo Company's platoons was unable to move due to the intensity of enemy fire.
- One of Bravo Company's vehicles was disabled by one or several RPGs and required recovery.²¹

Bravo and ING companies had to fight through a "linear ambush" for the 1,500 m between them and the crash site, according to the Bravo Company commander. The company commander stopped lead elements of the column in a wide intersection to study his map of the city on FBCB2. Although his destination, the crash site, was clearly indicated on the map, and they were relatively near their goal, finding a feasible route to it was still a challenge. The column continued to come under intense RPG fire. In addition, a warning was issued that insurgents were throwing grenades from the upper floors of buildings onto the Stryker and ING vehicles. In response, Stryker and ING infantry teams from the stopped column were deployed to clear the nearby buildings and seize the urban high ground immediately surrounding the maneuver route. Enemy fire remained intense at the crash site and on the extended column of vehicles, which remained stopped for over 15 minutes.

During this time, the pinned-down platoon eventually freed itself from the enemy, and it was determined that the disabled Stryker vehicle could move a short distance to the open intersection where the command vehicles were now located and where it could be rigged for towing. In addition, the request for an immediate CAS mission was approved. The aircraft were now en route.

²⁰ Townsend, 2004.

²¹ Townsend, 2004.

Meanwhile, the column started moving again. Shortly thereafter, the lead elements turned a corner and arrived at the crash site at about 9:30 a.m. However, the column had arrived at the eastern edge of the crash site, not the western edge where they were needed. Enemy RPG and mortar fire was too great to directly traverse the open square where the crash site itself was located to take control of the western perimeter. Another maneuver operation was required. Also, heavy fire from insurgents prevented forces at the site from securing four buildings that formed an L-shaped “high ground” around the site, and UAV surveillance indicated another 20 or more insurgents entering the area, armed with RPGs and machine guns.

After the 5-20 commander and his staff had arrived at the site, they worked out a plan with the scout platoon leader to secure the site along its entire perimeter. The 5-20 commander then heard that two F-16s had arrived to provide CAS and directed that a joint direct attack munition (JDAM) hit a burning wall close to enemy positions. The Bravo company commander learned of the impending JDAM strike and presented a plan to take the four buildings on the western edge of the crash site immediately after the JDAM blast.

At 9:57 a.m., the JDAM hit on target. Immediately after the strike, enemy fire lessened considerably. The lead platoon of Bravo Company maneuvered along another circuitous route toward the western edge of the crash site. After a few false starts, it found a feasible route through the narrow streets to the western side of the crash site. Bravo Company soldiers charged and cleared the four critical buildings that overlooked the site. Now a tight perimeter defense had been created around the crash site.

Soon after, the 5-20 commander learned that someone in the local police department was directing locals to “protect the mosque from coalition forces” (the mosque was near the crash site, which led to a major upsurge in violence, including the use of 60mm mortar rounds), and a steady rain of RPGs began again. The SBCT forces largely repelled the attackers with the help of two tube-launched, optically-tracked, wire-guided (TOW) missiles, but the fighting continued. At 10:35 a.m., Charlie Company arrived, and a platoon of men rapidly recovered the helicopter onto a heavy truck. The 5-20 commander noted that “I couldn’t believe how prepared they were to recover this aircraft. It looked like they had rehearsed.”

Even after the helicopter had been secured, SBCT forces continued to face 60mm mortar fire. An F-16 was called in to strafe the area, after which the mortar attacks stopped. SBCT forces moved out at 11:30 a.m. The total casualty counts included about 110 enemy forces killed, an unknown number of enemy wounded, no U.S. deaths, five

U.S. wounded, one ING soldier killed, and at least two ING troops wounded (see Table 4.2).

A detailed analysis of the Tal Afar battle reveals that digital networking and C2 capabilities provided by FBCB2 and FBCB2-BFT played a strong role in the outcome. The SBCT’s improved situation awareness (in particular for blue force information) improved the tactical commander’s situation understanding and speed of command and enabled units in the battle of Tal Afar to dynamically synchronize their actions. Awareness of friendly force locations, situation understanding, and speed of command were especially important in the opening minutes of the engagement. In the first minutes after the crash, the 5-20 commander, the scout platoon, and Bravo Company were all able to identify the location of the crashed OH-58 and maneuver to it. The scout platoon was able to reach the site within five minutes of the crash; it took Bravo company a half-hour to consolidate near the crash site, but it had to fight its way through insurgent ambushes with heavy small arms and RPG fire over 3 km of narrow city streets.

As the engagement developed, SBCT soldiers maintained near-real-time knowledge of units’ positions throughout the engagement (positions were displayed on FBCB2) and maintained communications (either radio or face-to-face communications) throughout the engagement. Later, the unit commanders were able to commu-

Table 4.2
Battle of Tal Afar Total Mission Casualties

	Dead	Wounded
United States	0	5
ING	1	0
Total (coalition)	1	5
Total (Somalia)	110	?

nicate with the on-station F-16s, precisely directing their strikes. As a result, SBCT units were able to synchronize their actions throughout the engagement, as shown by Bravo Company's ability to conduct simultaneous flanking and charging of four key buildings immediately following the JDAM blast. They were able to plan rapidly and disseminate those plans, as shown by the initial planning to hold the site and Bravo Company's planning to take the four surrounding buildings. Finally, Charlie Company was efficient at conducting the helicopter recovery operations, despite not explicitly being told what equipment to bring and what to do at the crash site.

Seemingly unremarkable, but especially important, was that no Stryker or ING units became lost or were unable to locate key objectives or other nearby units. This was due to the superior situation awareness provided by FBCB2 and the digital SBCT tactical network. At times, units had difficulty in finding a trafficable route to specific parts of the crash site (the western edge), but they were able to take corrective action and reach their objective.

Comparison of Tal Afar and Mogadishu²²

A number of observations help explain why the Tal Afar incident evolved much differently than the Battle of Mogadishu. But first, it is instructive to review the forces employed in the both battles. In Mogadishu, U.S. forces initially were equipped with 12 lightly armored ground vehicles, 18 helicopters, and one P-3 Orion spy plane. The initial force that was inserted into the city numbered about 160 soldiers. The ad hoc response force (AHRF) used to extract the original units from the city employed 28 Malaysian armored personnel carriers and four Pakistani tanks. In all, the AHRF employed over 100 vehicles and over 500 U.S. soldiers.

The 3/2 SBCT Task Force 5-20 was composed of 22 Stryker vehicles, about 20 ING pickups and jeeps, two OH-58s (lightly armed), and one Shadow UAV. The task force included about 200 U.S. soldiers and approximately 160 ING soldiers. Later, it was augmented by Charlie Company, which added another dozen or so Stryker vehicles and another 150 or so soldiers. A comparison of these forces is given in Table 4.3.

The table indicates that, while U.S. forces in Mogadishu did not initially have armored vehicles at their disposal, when the ad hoc reaction force was later deployed to extract U.S. units from the city, it had a substantial armored column and infantry

²² We remind the reader that in this vignette analysis, our purpose is not to evaluate mission effectiveness; instead, we wish to assess and compare the information sharing capabilities between the two different forces.

Table 4.3
Forces Employed in the Battle of Tal Afar and Mogadishu

Operation	Armored Vehicles	Lightly Armored Ground Vehicles	Coalition Forces	Aircraft
Tal Afar ^a	22/40	~45	~370/530	4
Mogadishu ^b	0/32	12/68	160/660	20+

^a Denominators include the Charlie Company helicopter extraction force.

^b Denominators include AHRF.

force, which included a large number of U.S. soldiers. Also, it should be noted that an entire ING in Tal Afar had absolutely no armored support for the entire engagement. Despite this, it suffered only a single casualty.

Also highlighted in the table is the large array of rotary-wing assets that were available to U.S. forces in Mogadishu. These Black Hawk and Little Bird helicopters were equipped with miniguns, and the AH-6 gunships were equipped with rockets, which provided substantial CAS to units on the ground. While armor and CAS played a significant role in limiting U.S. casualties in Tal Afar, these capabilities were not absent in the battle of Mogadishu. In fact a far greater amount of CAS was available in Mogadishu than in Tal Afar. However, U.S. units were without armor for the first 13 hours of the battle in Mogadishu. Lack of armor initially was a key contributor to U.S. casualties. But the fact that U.S. forces were pinned down so long in the city was also due to the poor situation awareness and communications capabilities of U.S. forces on the ground.

It should be noted that reliable data on the strength of enemy forces in both battles are not available. Anecdotal accounts indicate that enemy forces that participated in the Battle of Mogadishu were several thousand strong. Enemy forces in Tal Afar appeared to be no larger than several hundred, but these are only estimates. So there seems to have been an order of magnitude difference in the size of the enemy force encountered in each case. However, in both cases, the enemy forces swarmed to the battle mostly on foot. So again, the longer exposure time for U.S. forces in Mogadishu contributed to their encountering a larger enemy force.

There was a substantial difference in the C2 and networking capabilities of the two forces. Coalition forces in the battle of Mogadishu relied solely on voice communications and paper maps. Once on the ground, U.S. units in the city were unable to consistently locate and follow designated routes and locate crash sites and surrounding

units, and they could not communicate effectively with each other or with the P-3 Orion circling overhead. Because units were not on the same voice communications subnets, they had to funnel communications back through the Black Hawk, which at times created a voice gateway bottleneck.

These shortcomings reduced situation awareness, slowed speed of command, and prevented the GRF and the initial QRF from locating or physically arriving at the two crash sites.

Finally, the units in the Battle of Mogadishu did not have contingency plans for multinational rescue missions, and units on the ground did not have a single ground commander, which resulted in further problems with speed of command and synchronization. The result, as discussed above, was a great deal of critical time spent attempting to assess the situation, establish communications means between units, and come to a common agreement on what to do; a number of significant errors were made due to a lack of understanding about the operational situation.

As described above, the level of blue force situation awareness, including awareness of the crash site, speed of command, and unit self-synchronization, was much greater in the Tal Afar incident than in the Battle of Mogadishu. Stryker units could locate fellow units and the crash relatively quickly; when enemy forces were reported on FBCB2, Stryker units could locate them relatively easily and respond accordingly.

Clearly, the time required to execute both operations was an important factor. The longer that U.S. forces were exposed, the greater the chances they would suffer casualties. The SBCT operation was completed in just over three hours, a much shorter time than the Battle of Mogadishu, which lasted over 15 hours. Superior situation awareness information, situation understanding, speed of command, and synchronization were all key enablers (but not the only factors) that contributed to the superior mission effectiveness (i.e., reduced time for rescue and reduced coalition casualties) exhibited by Task Force 5-20 in Tal Afar compared with the battle of Mogadishu. In addition, having armor from the start of the operation and the smaller enemy force encountered in Tal Afar contributed to mission success.

Stability Operations Intelligence Needs

The above discussion of the battles of Mogadishu and Tal Afar also illustrates how U.S. intelligence needs for combat operations and counterinsurgency are different. Just as the spectrum of military missions changes significantly from MCO to stability operations, so, too, have intelligence needs changed for U.S. forces on the ground.

The Battle of Tal Afar illustrates some important factors regarding the challenges in gathering intelligence and situation awareness in stability operations. Later in the engagement, a significant problem was that the local police station was sending out a radio appeal to “protect the mosque from coalition forces,” which dramatically increased the level of violence. This could have been caused either by a failure to coordinate with the local police station (a breakdown in communications with local officials) or by the local police department being heavily infiltrated by insurgents (a breakdown in red force awareness).

Both shortcomings can be explained by a lack of sustained force presence and a lack of a reliable intelligence collection in the city. Nonetheless, despite being surprised, the 3/2 SBCT was able to turn a major insurgent attack into a substantial victory, avoiding any U.S. combat deaths and the compromise of U.S. technology on the downed helicopter.

An examination of events indicates that there were some deficiencies in the areas of red force awareness regarding the level of insurgent activity and infiltration into the city of Tal Afar. This affected planning for the original operation and appears to have had a strong negative effect on the 3/2 SBCT, exposing its units to significant threat. The most significant problem was simply that the SBCT units were surprised by the number, armament, and coordination of the insurgents they faced during the engagement; the SBCT units were ambushed by a sizable, well-armed insurgent force. Early on in the engagement, the scout platoon initially at the site found itself outnumbered by over three to one and feared being overrun until reinforcements arrived. Bravo Company was also surprised by the number of insurgents and the heavy fire it faced.

Lack of a sustained force presence in the city, a language barrier, lack of cultural awareness as to the ethnic composition of the area, and the sensitivity of the local populace toward their religious sites all contributed to a possible increase in attacks on Task Force 5-20. For further discussion of intelligence needs for stability operations, we refer the reader to Annex A of the classified annexes to this monograph.

Need for Precise Intelligence

As mentioned earlier in this chapter, urban sweeps in stability operations can be counterproductive. HVT operations based on inaccurate or imprecise intelligence can also be counterproductive in the same way. In such cases, innocent Iraqis are disrupted, their property may be damaged or destroyed, and they may be injured or killed. These unintended consequences can turn Iraqi civilians against the Iraqi government and U.S. military forces. Consequently, Stryker units have attested to the need to obtain

precise actionable intelligence or to forgo operations that can lead to such unintended consequences if that intelligence is not available.²³ Further, precise, actionable intelligence on HVTs and other mobile targets is perishable and rapidly loses its value if it cannot be transmitted to the tactical level quickly for action. Consequently, responsive networking capabilities down to the tactical level, such as those available in the Stryker brigades, are necessary to effectively exploit precise actionable intelligence.

²³ U.S. Army Infantry School, 2006.

Mission Effectiveness in Stability Operations

In this chapter, we examine the mission effectiveness in stability operations of the 101st ABD, the 3/2 SBCT, and the 1/25 SBCT to discern where NCO capabilities or other factors contributed to an increase (or decrease) in mission effectiveness. Previous chapters have illustrated how the NCO capabilities have enabled the SBCTs to operate effectively—arguably more effectively than conventional units—in tactical stability operations, while the 101st ABD was more effective in reconstruction activities because of the additional manpower, funding, and engineering resources it had at its disposal and because of effective command leadership. What matters, of course, is whether these unit capabilities translate into an overall strategic effect on the battlefield and to help stabilize the country of Iraq. To determine whether they do, we use the U.S. strategic objectives in Iraq to assess overall mission effectiveness in stability operations.

U.S. Strategic Objectives and MNF-I Campaign Plan

U.S. objectives for the stability and reconstruction operations after the MCO phase of OIF have evolved over time. In November 2005, four major objectives were articulated in the U.S. strategy for victory in Iraq (see Table 5.1).¹ We use the first two objectives to assess the mission effectiveness of stability operations undertaken by each unit.

The first security goal is to defeat terrorism and neutralize the insurgency in Iraq. The U.S. “Clear, Hold, and Build” strategy for achieving these security goals is to do the following:

¹ *National Strategy for Victory in Iraq*, Washington, D.C.: The White House, November 2005.

Table 5.1
U.S. Strategic Goals in Iraq

Political	Forge a broadly supported national concept for democratic governance
Security	Defeating terrorists and containing insurgents
Security	Training and deployment of Iraqi security forces
Economic	Establishing a sound and self-sustaining economy

Assessed Not assessed

- *Clear* areas of enemy control by remaining on the offensive, killing and capturing enemy fighters and denying them safe-haven.
- *Hold* areas freed from enemy influence by ensuring that they remain under the control of the Iraqi government with an adequate Iraqi security force presence.
- *Build* Iraqi security forces and the capacity of local institutions to deliver services, advance the rule of law, and nurture civil society.²

U.S. military forces in Iraq have the primary role in attempting to achieve the first security goal above, and it plays a central role in our assessment of unit performance.

The second security goal is to develop and train Iraqi security forces (ISF) so they eventually can become self-sufficient and enable the withdrawal of U.S. forces. We do not use this objective to assess U.S. unit performance for several reasons: Reliable Iraqi unit performance data were not available, it could not be determined how and whether Stryker brigade NCO capabilities played a role in training, and some ISF, in particular Iraqi police forces in Mosul, received training in Jordan by organizations that are beyond the scope of this assessment. Nevertheless, it is important to note that progress has been made in achieving the second security goal in northern Iraq. The western half of the city of Mosul was turned over to ISF in January 2006, only a few months after the 1/25 SBCT rotated out of Iraq. The 101st ABD, 3/2 SBCT, and the 1/25 SBCT all were responsible for training ING battalions.

² *National Strategy for Victory in Iraq*, 2005.

The political goal is to “forge a broadly supported national compact for democratic governance.” To achieve this goal, the U.S. government’s stated approach is to *isolate* Iraqi insurgents, foreign fighters, and terrorists from Iraqi citizens, and encourage Iraqi participation in the political process and support the fledgling Iraqi government. We assess the contribution of each unit toward accomplishing this goal.

The economic objective is not used to assess unit mission effectiveness because reliable economic data for northern Iraq were not available.³

The main elements of the U.S. military stability operations campaign plan for achieving stability in Iraq are shown in Figure 5.1. The long-term goal of the plan is to transfer local control to legitimate Iraqi authorities. To achieve this desired end state, the campaign plan is based on the five lines of development illustrated by the arrows shown in the figure. The first two lines of development are similar to the security objectives laid out in U.S. strategy for Iraq. The other three lines of development

Figure 5.1
Multi-National Forces–Iraq Campaign Plan

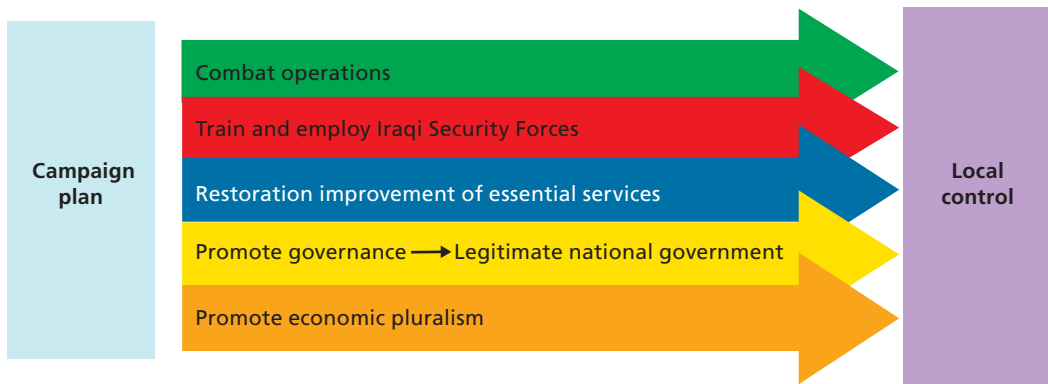

SOURCE: Metz, 2005.

RAND MG593-5.1

³ Suitable economic assessment measures are growth or contraction of the Iraqi economy (GDP) in the AOR, price stability or inflation, unemployment rate, stable currency exchange rates, and the provision of essential services (e.g., electricity) to the populace. These data are available for all Iraq but not for northern Iraq. Nor do we have comprehensive data on projects started and completed by the 101st ABD and SBCTs in northern Iraq.

are consistent with the economic and political objectives of U.S. strategy. The desired end state for the MNF-I campaign plan is a stable and democratic Iraqi government with participation from all major ethnic groups.

We include this brief description of the MNF-I campaign plan to illustrate the point that U.S. military forces in Iraq are tasked to accomplish more than just the security objectives associated with the U.S. strategy.

Assessment Framework

It is difficult to assess mission effectiveness of units conducting stability operations and even more difficult to ascribe mission effectiveness results to a single military unit in a particular area for a particular period of time in a long war or campaign. As explained below, many external factors can influence the course of events that are beyond the control of particular military units. Nevertheless certain inferences can be made using the assessment framework described in Chapter One (see Figure 1.2).

To examine progress toward achieving the first two strategic goals, we use assessment measures associated with the U.S. strategic goals reviewed above, in which U.S. military forces can reasonably have a positive effect.

Political Goal Assessment Measures

The assessment measures we use to assess political progress are shown in Table 5.2. Four measures of effectiveness (MOEs) are used. The first is the stability of local gov-

Table 5.2
Political Goal Assessment Measures

MOEs	MOPs
1. Stable local government and security institutions	1.1. Functioning, longevity, or collapse of local government or security institutions
2. Legitimacy of local government	2.1. Number of participating senior leaders
	2.2. Multiethnic composition
3. Popular support of local Iraqi government and U.S. security forces	3.1. Number of calls to tip lines
	3.2. Trust of Iraqi people
4. Completion of elections	4.1. Voter turnout
	4.2. Civilian casualties on election day
	4.3. Reports of attacks on polling sites

ernment institutions (for the relevant provinces of northern Iraq), which we assess using one or more measures of performance (MOPs). Where data are available, we use institutional longevity, effective or ineffective functioning, or the collapse of local government institutions as MOPs.⁴

The second MOE is the legitimacy of the local government, which we assess by the number of local tribal and regional leaders that participate in the governance process, whether the regional councils had a multiethnic composition or not, and whether or not local elections were held to appoint government leaders.

The third MOE is popular support for the local government and coalition security forces. Here we must rely on anecdotal evidence from soldier interviews (willingness of people to talk to soldiers) and press articles, as well as tip-line data, because population survey data was not available.

The fourth MOE is the peaceful completion of national elections. Here, reports of attacks on polling sites, civilian casualties on election day, and voter turnout numbers are used as MOPs.

Security Goal Assessment Measures

The four MOEs used to assess progress in achieving the first U.S. security goal are shown in Table 5.3. We use four MOPs for assessing the first MOE—to determine whether U.S. military stability operations contributed to increasing the safety and security of the populace. The first two MOPs for MOE No. 1 are measures commonly used in press reporting to indicate the level of violence and instability in Iraq. For the third MOP, definitive quantitative information is not available, but some relevant anecdotal information can be found in press reports. The last MOP, key civilian leaders killed, is an important measure not only of lack of stability in the country but also of the capabilities of insurgent groups—their ability to overpower Iraqi government security forces, or to obtain inside information concerning the movements of key leaders and to plan attacks that exploit weaknesses in coalition defenses. Hence we use this MOP twice, as indicated in the table for MOEs No. 1 and No. 2. Similarly, we also use civilian casualty data, including the rate of increase or decrease in civilian casualties, to assess MOE No. 2—the effectiveness of enemy attacks.

We use three MOPs for assessing MOE No. 3—the effectiveness of coalition operations: the number and priority of insurgent leaders captured or killed, the number

⁴ Note that we explicitly exclude the functioning or effectiveness of the national government or CPA in this assessment because these factors are beyond the control or scope of the military units assessed.

Table 5.3
Security Goal Assessment Measures

MOEs	MOPs
1. Security and safety of the populace	1.1. Numbers and trends in civilian deaths in Mosul AOR vs. Iraq-wide 1.2. Numbers and trends in enemy attacks in Mosul AOR 1.3. State of commerce: number of shops open, other reports 1.4. Key civilian leaders killed
2. Effectiveness of enemy attacks	2.1. Numbers and trends in civilian deaths in Mosul AOR vs. Iraq-wide 2.2. Key civilian leaders killed
3. Effectiveness of coalition operations	3.1. Number of insurgent leaders captured or killed 3.2. Number of raids vs. number of sweeps 3.3. Control of city access points
4. Force protection effectiveness adjusted for OPTEMPO	4.1. Coalition KIA per enemy attack in Mosul vs. Iraq-wide 4.2. Coalition WIA per enemy attack in Mosul vs. Iraq-wide 4.3. Coalition KIA per U.S. operation in Mosul vs. Iraq-wide 4.4. Coalition WIA per U.S. operation in Mosul vs. Iraq-wide 4.5. Numbers and trends in coalition casualties in Mosul vs. Iraq-wide

of raids versus the number of sweeps conducted, and the ability of coalition forces to control access to the city of Mosul. A high priority for coalition counterinsurgency operations has been the capture or elimination of insurgent leaders or insurgents with special skills that increase insurgent attack effectiveness. Also, as discussed previously, untargeted operations, such as sweeps of entire city blocks or neighborhoods, can generate significant animosity among the populace, especially when property is damaged, lives are disrupted, and Iraqi women are mishandled, even if inadvertently, by U.S. forces. On the other hand, raids targeted at specific individuals disrupt the Iraqi populace to a much lesser extent and lead to less resentment of coalition forces among the populace. If these operations are based on accurate intelligence, they can lead to the apprehension of wanted suspects or insurgents. The final MOP for this MOE relates to the freedom of movement for insurgents carrying weapons or explosives. If insurgents have free access to the city and can transport weapons and fellow insurgents into the city at will, they can mass forces for attacks and reinforce cell members in cities. Finally we use five MOPs to assess the fourth MOE—force protection effectiveness adjusted for unit OPTEMPO. It is necessary to adjust for unit OPTEMPO to get an accurate picture of force protection effectiveness. For example, if the unit had relatively low casualties but

rarely encountered or sought out enemy forces, low casualties would not be a good measure of force protection capability. Also because insurgent activity grew from a relatively low level from mid 2003 to 2005 and the IED threat did not become predominant until 2004, it is useful to compare units that were operating in northern Iraq with U.S. units that were operating elsewhere in the country to assess force protection effectiveness.

Assessment of Effectiveness—Political Progress

We now examine the performance of each military unit.

101st ABD

We start with the 101st ABD and examine the political progress that was achieved during its rotation from May 2003 to January 2004 (see Table 5.4).

In our review of available data, we found that the 101st ABD was effective in establishing a new governance structure for northern Iraq shortly after major combat operations were declared over. The 101st was able to ensure Sunni Arab participation in the local government. Local elections for some positions were held, although individuals were appointed to some key positions rather than elected. This governance

Table 5.4
Summary of Political Progress Assessment for 101st ABD

MOEs	MOPs	Observables
1. Stable local government and security institutions	1.1. Functioning, longevity, or collapse of local government or security institutions	Regional council established local elections held Collapse of Mosul police department
2. Legitimacy of local government	2.1. Number of participating senior leaders 2.2. Multiethnic composition	Reported support Sunni participation
3. Popular support of local Iraqi government and U.S. security forces	3.1. Number of calls to tip lines 3.2. Trust of Iraqi people	Not available Anecdotal evidence positive—extensive social networking with local leaders
4. Completion of elections	4.1. Voter turnout 4.2. Civilian casualties on election day 4.3. Reports of attacks on polling sites	Not available Not available Not available

structure appears to have functioned largely unchanged from early summer 2003 to at least November 2003.⁵

In the fall of 2003, the CPA made a major course correction in its plan for achieving Iraqi self-governance. Ambassador Bremer announced on November 15, 2003, that the coalition would hand over sovereignty to the Iraqis by June 30, 2004. This handover plan would rely on a system of provincial council caucuses. Ambassador Bremer ordered the provincial councils be “refreshed” with new “vetted” members. The “refreshment” of existing councils meant removing former Ba’ath party members and ideally expanding the membership to make the bodies more representative. An effort was made to standardize the process across all of Iraq. This process took some time to implement. It was not always viewed as fair and appears to have reduced the legitimacy of the local government in many areas. In March 2004, the governor of the Ninawah province, Ghanim Sultan Abdullah al-Basso, was dismissed from his job by the CPA because of alleged corruption and links to the Ba’ath party. However, he appears never to have been officially charged with corruption.⁶ This change in leadership may have reduced Sunni support for the local government in Ninawah province just after the military authority for the region was handed from the 101st ABD to the 3/2 SBCT.

Stability was a challenge for some government institutions in northern Iraq during this time. The Mosul police department collapsed in July 2003 when former Iraqi Army veterans rioted in the streets, demanding their salaries. Several demonstrators were shot and killed by the police. These riots were precipitated by the decision of the CPA to disband the Iraqi army. It appears that the collapse of the police department was brought about by external factors (an ill-advised CPA policy). The police department was rebuilt relatively quickly under the leadership of a new police chief.⁷ However, the Mosul police chief was seriously wounded in August 2003, and the deputy police chief was killed in February 2004.⁸

Despite setbacks with the Mosul police department, significant political progress was made by the 101st ABD during its tenure in northern Iraq. Reports indicate that

⁵ Celeste J. Ward, *The Coalition Provisional Authority's Experience with Governance in Iraq: Lessons Identified*, Special Report 129, Washington, D.C.: United States Institute of Peace, May 2005.

⁶ “Baghdad Daily Reports on Dismissal of Mosul Governor,” *RFE/RL Newline*, April 1, 2004.

⁷ “Lessons of the Iraq War and Its Aftermath,” 2004.

⁸ “Mosul Police Chief Shot,” *BBC World Service*, August 16, 2003; “Mosul Deputy Police Chief Assassinated,” *Guardian Unlimited*, February 25, 2004.

conditions on the streets of Mosul were significantly better than those in Baghdad by August 2003.⁹ In Baghdad that month, the UN headquarters building was bombed and the UN ambassador was killed along with several others. Shops closed on Baghdad streets and CPA representatives had to be very cautious when venturing outside of the Green Zone in the Iraqi capital.

3/2 SBCT

We now consider the degree of political progress or regression achieved during the tenure of the 3/2 SBCT in northern Iraq (see Table 5.5). We have already mentioned decisions made by the CPA in March 2003 that appear to have reduced the legitimacy and support for provincial councils across Iraq, including in Ninawah province. We categorize these developments as external factors, or factors beyond the control of the local military unit that nonetheless adversely affected stability operations in northern Iraq.

A second significant external factor that was detrimental to political progress was the assassination of the new governor of Mosul, Ussama Kachmula, who was also the head of the Ninawah provincial council. The governor was of Kurdish descent. He was killed on his way to Baghdad, about 110 km south of Mosul, outside of Ninawah

Table 5.5
Summary of Political Progress Assessment for 3/2 SBCT

MOEs	MOPs	Observables
1. Stable local government and security institutions	1.1. Functioning, longevity, or collapse of local government or security institutions	Regional council collapsed or became inactive Second collapse of Mosul police department
2. Legitimacy of local government	2.1. Number of participating senior leaders 2.2. Multiethnic composition	Reduced participation Reduced Sunni participation
3. Popular support of local Iraqi government and U.S. security forces	3.1. Number of calls to tip lines 3.2. Trust of Iraqi people	Not available Reduced relative to 101st ABD
4. Completion of elections	4.1. Voter turnout 4.2. Civilian casualties on election day 4.3. Reports of attacks on polling sites	None held Not applicable Not applicable

⁹ Gordon, 2003; Ward, 2005.

province, in July 2004.¹⁰ His death probably reduced support for the provincial council among the Kurdish population and increased sectarian tensions, which were already high in Mosul.

A third external factor detrimental to political progress was the reduction in reconstruction funds available to the 3/2 SBCT. As discussed at length previously, the 101st ABD had access to \$31 million in CERP funding, which was used effectively for reconstruction projects in northern Iraq. During its tenure in northern Iraq, the 101st ABD was the largest employer in the region.¹¹ Interviews with Army commanders of both units indicate that a number of explicit or implied promises were made to local Iraqi leaders regarding reconstruction projects in their areas concerning projects that would be continued, started, or finished in 2004. When the 3/2 SBCT arrived on the scene, it was given far less funding to support reconstruction efforts. Consequently, it had no choice but to break those promises to local leaders. In addition, it is likely those local leaders then suffered a loss of credibility with their own people and supporters when the promised reconstruction projects did not materialize. These external factors clearly had a detrimental act on political progress. Reduced support from local leaders caused intelligence sources on the insurgency to “dry up,” perhaps forcing the 3/2 SBCT to execute sweeps instead of targeted raids.

The security situation in Mosul continued to deteriorate during the spring and summer of 2004. Elements of the 3/2 Stryker brigade conducted sweep operations in large areas of the city during this time. While we have no direct evidence of whether these sweep operations had a negative effect, such operations have been found to generate significant resentment in the population in other cases in Iraq.

Interviews with Army commanders indicate that Stryker brigade soldiers interacted less frequently with local Iraqi political and religious leaders and with Iraqi security forces than soldiers of the 101st ABD did. This lower level of social networking may be attributed to the reduced number of MPs and chaplains available to the brigade (as discussed previously) and also to the large number of out-of-area operations conducted by elements of the brigade (at the direction of MNF-I headquarters). These out-of-area operations resulted in fewer “boots on the ground” in Mosul and fewer U.S. military leaders in the city. In addition, because Stryker soldiers were absent from

¹⁰ “Governor of Mosul Killed in Iraq,” *RTE News*, July 14, 2004; Rory McCarthy, “Gunmen Kill Mosul Governor,” *Guardian*, July 15, 2004; “Iraqi Governor Killed in Attack,” *BBC News*, July 14, 2004.

¹¹ Michael Knights, “Lessons from Mosul,” *PolicyWatch*, No. 950, Washington, D.C.: Washington Institute for Near East Policy, January 27, 2005.

northern Iraq for long periods, they were less familiar with the local populace and with the city's neighborhoods. Such local cultural awareness has been identified as essential for successful counterinsurgency operations.

It is plausible that this reduced level of social networking and the large number of sweep operations conducted in the city by the 3/2 SBCT reduced the level of trust the local populace had in coalition forces and in the local government. These same factors may have also reduced the level of trust local leaders had in coalition forces. Interviews with Army commanders who served in northern Iraq indicate that the Ninawah provincial council essentially collapsed sometime during the latter part of 2004. Press reports have not been found to corroborate this, but it is consistent with statements made by COL Robert B. Brown, commander of the 1/25 SBCT.

On the basis of the above measures of performance, we conclude that coalition forces suffered significant political setbacks in northern Iraq during the tenure of the 3/2 SBCT. These political setbacks can be attributed to a combination of external factors that were beyond the control of the 3/2 SBCT (including the reduced force presence of the 3/2 SBCT in Mosul and surrounding areas), the type of operations the 3/2 SBCT conducted in the city, its reduced organizational capabilities (numbers of attached MPs, chaplains, and engineering units for reconstruction efforts), and—perhaps most important—the much smaller amount of funding the 3/2 SBCT had available for reconstruction, which resulted in broken promises to local leaders.

1/25 SBCT

We now consider whether political progress was achieved during the tenure of the 1/25 SBCT (see Table 5.6). Things did not start off well for the 1/25 SBCT when it was first deployed to northern Iraq.¹² Sizable elements of the brigade were diverted to Fallujah to assist with the siege there. At the same time, insurgents in Fallujah escaped and headed north to Mosul. Perhaps because of the rising ethnic tensions in the city and because the police department had been infiltrated by insurgents (including with possible assistance of the police chief), the Sunni insurgents from Fallujah found it relatively easy to infiltrate the city and establish operations there. About this time, the chief of police in Mosul was accused of corruption. Just as he fled the city, insurgents carried out a series of coordinated attacks against police stations and other key sites in the city. The police department in Mosul collapsed for the second time since the inva-

¹² Knights, 2005.

Table 5.6
Summary of Political Progress Assessment for 1/25 SBCT

MOEs	MOPs	Observables
1. Stable local government and security institutions	1.1. Functioning, longevity, or collapse of local government or security institutions	Regional council reestablished Mosul police department strengthened
2. Legitimacy of local government	2.1. Number of participating senior leaders	Increased by a factor of 10
	2.2. Multiethnic composition	Yes
3. Popular support of local Iraqi government and U.S. security forces	3.1. Number of calls to tip lines	Increased by a factor of 10
	3.2. Trust of Iraqi people	Anecdotal evidence positive—extensive social networking with populace, local leaders
4. Completion of elections	4.1. Voter turnout	Yes, increasing
	4.2. Violence or civilian casualties on election day	Some in January 2005 election None in October 2005 election
	4.3. Reports of attacks on polling sites	Not available

sion.¹³ In many ways, this was the low point for stability operations of the 1/25 SBCT in northern Iraq.

Colonel Brown of the 1/25 SBCT stated a few days after the November attacks that operations in Mosul would differ greatly from the ferocious sweeps that leveled the Sunni strongholds of Fallujah and Samarra. As Colonel Brown noted, “You are using intelligence to go precisely where the enemy is, you go and find them where they are and allow them no safe harbor.”¹⁴ The 1/25 SBCT conducted targeted raids along these lines for much of its tenure in northern Iraq.

After Fallujah, the 1/25 SBCT conducted many fewer out-of-area operations than did the 3/2 SBCT Stryker brigade. In addition, it was augmented by the 3rd ACR for the latter half of its rotation in northern Iraq. The 3rd ACR conducted border security operations along the Syrian border in Ninawah province and counterinsurgency operations in Tal Afar from September 2005 to February 2006. This enabled the 1/25 SBCT to maintain a larger force presence in the city of Mosul and helped its troops to become familiar with local people and neighborhoods.

¹³ “Iraqi Soldiers Found Murdered in Mosul,” *Sydney Morning Herald*, November 22, 2004.

¹⁴ “Iraqi Soldiers Found Murdered in Mosul,” 2004.

Leaders and soldiers of the 1/25 SBCT also made a much greater effort to gain the trust of the local populace. This is substantiated by press reports and interviews with the soldiers of the 1/25 SBCT. This emphasis on social networking enabled 1/25 SBCT leaders to forge compromises between opposing Iraqi groups and to facilitate power-sharing arrangements among many of these groups.¹⁵

Another area of emphasis was the provision of security for national elections. While difficulties were encountered in the first election of January 2005 (a sizable number of election workers were intimidated into quitting before the election and a few polling sites were overrun by armed gunmen to prevent voting), the second national election in October 2005 was carried out in northern Iraq with little if any violence and no civilian casualties on election day. Details regarding the October national election can be found in Appendix D.

Voter turnout was significantly higher in October 2005 than it had been in the January 2005 elections. The dramatic change in voter turnout in Ninawah province from January to October 2005 occurred because many Sunni political parties decided not to boycott the election. But it also indicates the 1/25 SBCT improved security and stability in northern Iraq, thereby ensuring that Iraqis of all ethnic backgrounds who wanted to vote could vote in this critical part of the country, despite widespread insurgent threats.

The above operations and the emphasis on social networking led to increased legitimacy for local governing bodies and increased participation in these organizations, as shown in Table 5.6.

While quantitative data are difficult to come by, an interview with the commander of the 1/25 SBCT, Colonel Brown, sheds some light on the level of Iraqi participation in government. According to Colonel Brown,

The government has really improved their [sic] legitimacy. They've had significant economic recovery up here, excellent political participation in Nineveh province from a security council where no one would meet before the last elections to now we recently had a regional security conference with some 300 participants and 400 in the southern part of Nineveh province, so a lot of folks participating.¹⁶

¹⁵ Kaplan, 2006.

¹⁶ COL Robert B. Brown, video teleconference from Mosul, Iraq, to the 3/2 SBCT Lessons Learned conference, March 23, 2005.

The degree to which the population is willing to cooperate with government and coalition security forces also provides another indication of political progress. Simultaneously, it also indicates the loss of control and ability to intimidate the population on the part of the insurgents. Again, quoting from Colonel Brown's interview,

When we first got here in October . . . no hotline existed. We opened a hotline; we got about 40 calls a month prior to January. The last six months, we're up to 400 calls a month. Every day the citizens are stopping us on the street telling us where a potential suspicious individual is who may be a terrorist, and telling us where they tried to plant IEDs and those types of devices.¹⁷

Furthermore, Iraqi government institutions grew during the tenure of the 1/25 SBCT. In particular, the police department grew significantly during the tenure of the 1/25 Stryker brigade—after encountering the setbacks in November 2004—from a few hundred loyal officers in November 2004 to over 9,000 officers by October 2005.

Consequently, we conclude that significant political progress was made in the tenure of the 1/25 SBCT as indicated in Table 5.6. What is remarkable about these achievements is that they were made despite a substantial shortage of reconstruction funding. The lack of adequate reconstruction funding to support 1/25 SBCT operations has been mentioned in press reports and in interviews with 1/25 SBCT soldiers.¹⁸

Assessment of Effectiveness—Defeating Terrorists and Containing the Insurgency

For the second U.S. goal—defeating terrorists and containing the insurgency—coalition forces made uneven progress in different regions of Iraq. Below, we use several assessment measures to compare security and stability in northern Iraq and the country as a whole. We also use these data to compare the performance of the 101st ABD, 3/2 SBCT, and the 1/25 SBCT.

For this analysis, we use the MOPs defined in Table 5.3 to assess effectiveness of the military units against four MOEs:

¹⁷ COL Robert B. Brown, video teleconference, 2005.

¹⁸ Kaplan, 2006.

1. security and safety of the populace
2. effectiveness of enemy attacks
3. effectiveness of coalition operations
4. force protection adjusted for OPTEMPO.

For the first MOE we examine the following:

- trends in insurgent attacks
- trends in civilian casualties
- conditions, or the “level of normalcy,” in the city of Mosul over time, comparing them to conditions in Baghdad
- the survivability of local Iraqi government leaders.

Levels of Insurgent Attacks

Insurgent attacks against coalition forces in all of Iraq and in northern Iraq are shown in Figure 5.2. These data are from the CENTCOM significant actions (SIGACTs) database. One can see that throughout Iraq enemy attacks increased significantly from 2003 to 2005. The number of attacks remained high in 2005 but fluctuated considerably. For example, enemy attacks spiked leading up to and following the two Iraqi elections shown.

Enemy attacks against U.S. forces in northern Iraq shown in Figure 5.2 indicate similar trends. Note, however, that these data include attacks both against SBCT units and against other coalition units operating in AO North (such as the 3rd ACR). In northern Iraq, enemy attacks increased significantly from 2003 to 2005, and the overall number of attacks remained high there in 2005.

Figure 5.3 shows the percentage increase or decrease in enemy attacks in the Mosul AOR during the rotation of the 101st ABD, 3/2 SBCT, and 1/25 SBCT. From the beginning of the 101st ABD’s deployment until the transition period when the 3/2 SBCT rotated in, the number of enemy attacks in the Mosul AOR actually increased by almost 200 percent. Attacks increased by 88 percent during the rotation of the 3/2 SBCT and dropped by 0.06 percent during the 1/25 SBCT rotation. While the overall number of enemy attacks increased in the Mosul AOR from May 2003 (when the 101st ABD first arrived) until October 2005 (when the 1/25 SBCT rotation was ending), insurgents were at a minimum unable to worsen conditions in Mosul during the tenure of the 1/25 SBCT. Below, we provide further details concerning insurgent

Figure 5.2
Enemy Attacks—Theaterwide and in AO North

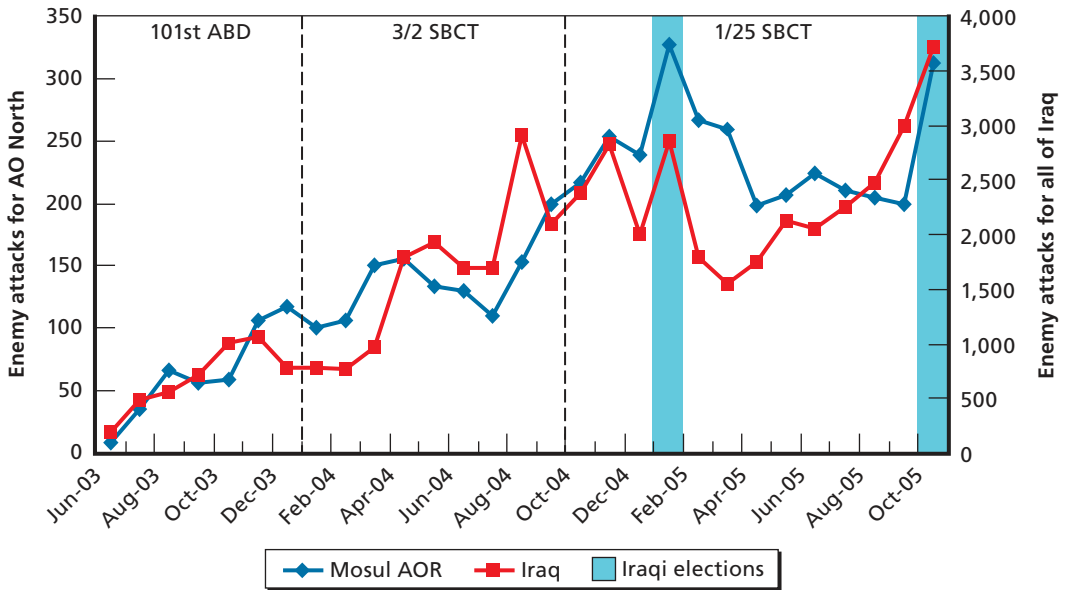

RAND MG593-5.2

attacks, which indicate the 1/25 SBCT appears to have been able to suppress an insurgency that was initially more active at the beginning of the 1/25 SBCT rotation than at the beginning of the rotations of the other two units considered (in other words, the 1/25 SBCT had the worst initial conditions of all three units in northern Iraq).

It may be surprising that insurgent attacks increased so dramatically during the tenure of the 101st ABD. However, if one reviews events in Iraq, it is clear that the insurgency grew significantly from May 2003 to January 2004. It was in August 2003 that insurgents bombed the UN headquarters building in Baghdad and killed the UN ambassador. Shortly after this, the streets of Baghdad became dangerous for ordinary Iraqis to navigate. Many foreigners, including most contractors and humanitarian assistance organizations, then left the country.

It is also important to note that other data indicate dramatic reductions in insurgent attacks during the tenure of the 1/25 SBCT. For example, Robert Kaplan reports that mortar attacks in Mosul fell from roughly 300 a month to fewer than ten a

Figure 5.3
Percentage Change in Enemy Attacks During Each Unit's Rotation

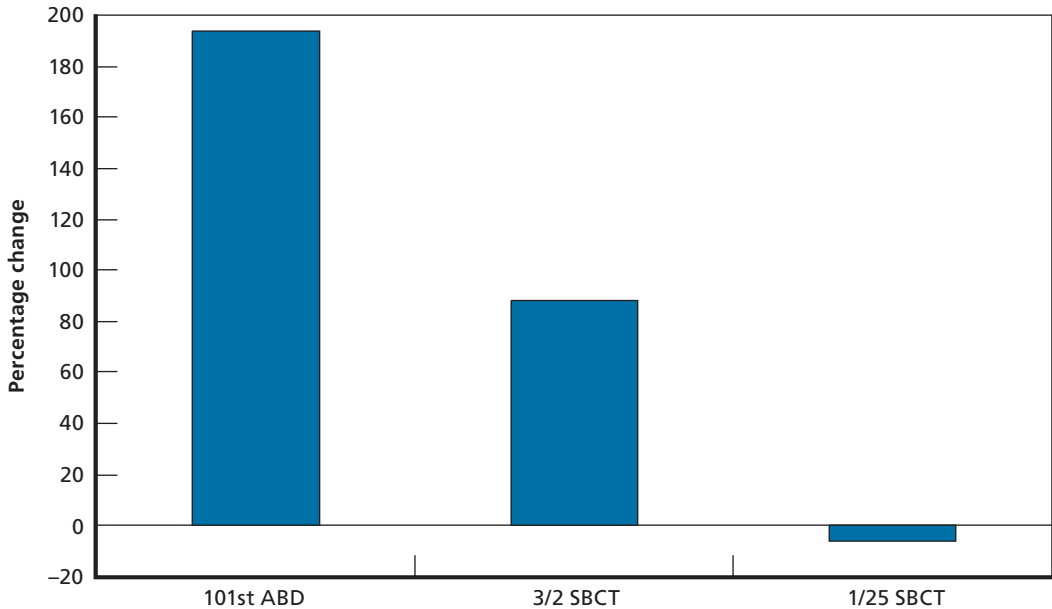

NOTE: Based on SIGACTs data only.

RAND MG593-5.3

month from the beginning of the 1/25 SBCT's rotation until the end.¹⁹ In addition, a classified intelligence assessment indicated that attacks fell by 30 percent in Ninawah province after several key Al Qaeda insurgent leaders were captured in mid-2005.²⁰ We have not attempted to reconcile all these data sources. Here we only note that the data on insurgent attacks do not appear to be precise. It is possible that the SIGACTs data may contain criminal activity reports that are incorrectly classified as insurgent attacks. Further, more specific data indicate that some classes of lethal attacks—those conducted with military equipment (mortars) that can be recorded accurately using automated means—fell by a factor of 30 during the tenure of the 1/25 SBCT.

¹⁹ Kaplan, 2006.

²⁰ See the classified annexes to this report for further details.

Civilian Deaths

A comparison of civilian KIAs shows a striking difference between the 1/25 SBCT’s main area of operations, Mosul, and the rest of Iraq. Figure 5.4 plots reported civilian KIAs by month for all of Iraq. The data are from a RAND internal database that combines the Iraqi body count database and the RAND terrorism database. As shown, the number of civilian KIAs per month surged in June 2004 and remained roughly flat or slightly increased thereafter throughout Iraq as a whole. Further, the data indicate that there had not been any sustained reduction in civilian casualties in Iraq overall after the peaks in February and August in 2005.

Figure 5.4 also plots reported civilian KIAs for Mosul. Compared with civilian KIAs elsewhere in Iraq, civilian KIAs in Mosul fall off sharply after June 2005. This pattern is consistent with reports of the 1/25 SBCT defeating a major insurgent

Figure 5.4
Civilian KIAs for All of Iraq and for Mosul

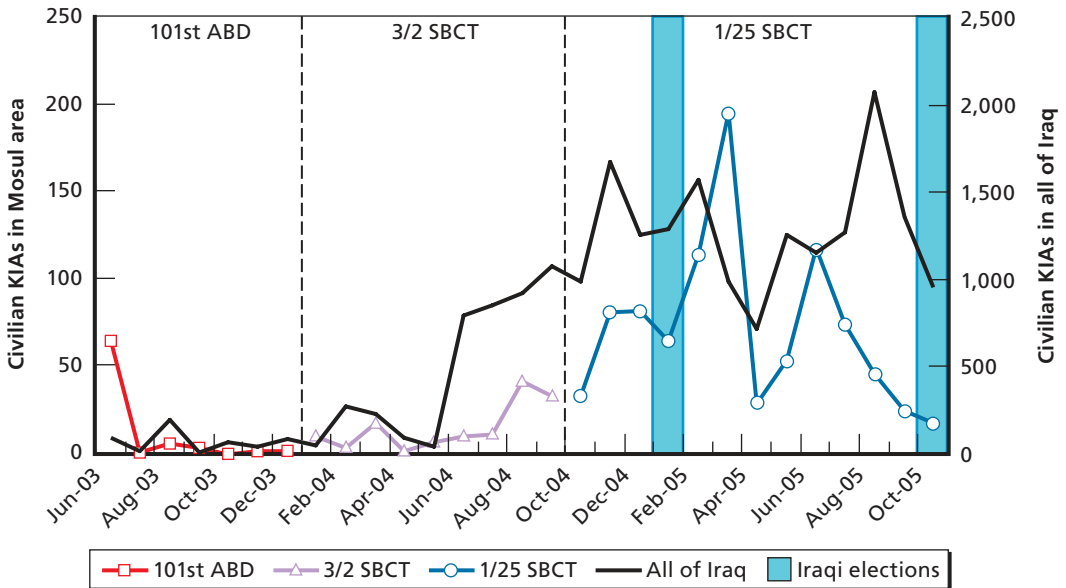

offensive in which Al Qaeda in Iraq and affiliated groups attempted to make Mosul a center of their operations.²¹

As shown previously in Figure 5.2, according to the SIGACTs database there appears to be no major difference in trends in enemy attacks between the Mosul AOR and Iraq as a whole. The major difference seems to be that the enemy's attacks were systemically *less effective* in Mosul than elsewhere in Iraq. In other words, after the insurgent leadership was eliminated in Mosul and many experienced insurgents were captured or killed, enemy groups in Mosul had to turn to inexperienced foreign fighters or Iraqis to carry out attacks. In some cases, for example, suicide bomber attacks were reportedly carried out by alcoholics or mentally ill individuals, as opposed to committed and experienced insurgents.²²

It should also be noted that the enemy has a role in setting the number of attacks, if insurgent forces can be resupplied and reinforced. One of the issues the SBCTs had to contend with in late 2004 and early 2005 was insurgents and foreign fighters entering northern Iraq from Syria, Jordan, and central or western Iraq. Failure to secure the borders (an MNC-I problem as much as an SBCT problem) and counterinsurgency operation failures in central Iraq, such as Fallujah, contributed to the rise in attacks in northern Iraq. Better results were achieved in mid to late 2005 under the 1/25 SBCT. During that time, a large berm was constructed around Mosul, the 3rd ACR took over Tal Afar, and other elements of the 3rd ACR moved to control parts of the Iraqi-Syrian border in Ninawah province. These measures reduced the flow of resources and insurgents into Mosul from Syria and elsewhere in Iraq.

In addition, it is important to keep in mind that insurgent forces initially did not target civilians in a widespread manner in 2003 or even in early to mid-2004, so civilian KIAs were relatively low then. It was only later that the insurgents turned their weapons against Iraqi civilians to incite sectarian tensions and eliminate their opponents in the Iraqi populace, especially those who were cooperating with coalition forces. When we take this fact into account, the reduction in civilian casualties achieved by the 1/25 SBCT is an even more dramatic indication of the improved security situation achieved in Mosul during its tenure. The 1/25 SBCT succeeded in protecting the civilian populace more effectively in Mosul than elsewhere in the country—even after the enemy had chosen to make cooperating Iraqi civilians a “center of gravity” in the conflict.

²¹ Metz, 2005. See also the classified annexes to this report.

²² Statements by 1/25 SBCT commanders and soldiers at the 1/25 Stryker Brigade Lessons Learned Conference, February 7–8, 2006.

As General George Casey stated in a handwritten note on the 2/4 Battalion's Valorous Unit Citation, "This may have been the best brigade in Iraq. Their return from the November collapse in Mosul to elections was brilliant against very tough opposition."²³

State of Commerce or Normalcy

We do not have authoritative or comprehensive data to estimate the state of commerce or the number of shops open in the Mosul during the different periods of time when the three units were in control of the city. However, we do have anecdotal evidence suggesting that conditions in the city, while not normal during the rotation of the 101st ABD, were relatively peaceful initially and slowly grew worse with the worsening secular trend of increasing violence in Mosul. Earlier in this chapter, we presented evidence to support the claim that conditions worsened in Mosul during the rotation of the 3/2 Stryker brigade and that these conditions carried over when the 1/25 Stryker brigade began its rotation and the Mosul Police Department collapsed in November 2004. Finally, there is press reporting and anecdotal evidence suggesting that conditions for commerce improved significantly during the rotation of the 1/25 SBCT and that conditions there were much better than in other parts of Iraq where insurgent forces are active, such as Baghdad.²⁴

Survivability of Iraqi Government Leaders

Another useful measure is the survivability of Iraqi government leaders in northern Iraq. While comprehensive data are not available, the chronology of events presented earlier in this chapter and in press reports indicates the following:

²³ The "November collapse" refers to the first month the 1/25 SBCT was in Iraq, when the police department in Mosul collapsed. See Kane, 2006; and Michael Yon, "The Punishers' Ball," *Michael Yon: Online Magazine*, November 17, 2005.

²⁴ Kaplan, 2006. Additionally, correspondent Sean Cockerham commented on the contrasting conditions in Mosul and Iraq:

I'm glad we had a chance to go on missions in both Baghdad and Mosul. I don't think people at home realize this, but they are really two completely different wars. Baghdad is a vicious, no-holds-barred war zone where even America's supposed allies, the Iraqi police and army, often can't be trusted. Everything there is about the Shiite-Sunni death match. In Mosul, there are many more cars on the streets and shops that are open.

"Leaving Iraq," *TheNewsTribune.com*, October 30, 2006.

- Relatively few government officials were killed or wounded during the tenure of the 101st ABD (the police chief of Mosul was wounded, and several judges were killed).
- Several key leaders were killed or fled during the tenure of the 3/2 SBCT (the Mosul deputy police chief was killed, the Mosul police chief fled, and the Ninawah provincial governor was killed).
- No high-level leaders were reported killed during the tenure of the 1/25 SBCT.²⁵

It should also be noted that the governor of Ninawah province was assassinated outside the province and in an area not controlled by the 3/2 SBCT.

Force Protection—U.S. Casualties

Traditional measures of military effectiveness, such as loss exchange ratio, are relevant in stability operations, especially in a counterinsurgency environment. However, we found it was not possible to compile reliable insurgent casualty figures. For this reason, we focus on U.S. casualties and force protection. The casualties suffered by the 101st ABD, 3/2 SBCT, and 1/25 SBCT are shown in Table 5.7 for the periods they were engaged in stability operations in Iraq.

The 3/2 SBCT had a significantly lower monthly casualty rate than the 101st ABD, even while insurgent activity was increasing. Even during a period of increasing attacks by the insurgency, 3/2 SBCT casualties per soldier were significantly less than the 101st ABD, and the 101st ABD's KIA rate was about 2.5 times greater than the 3/2 SBCT's. The 1/25 SBCT's monthly casualty rates were also lower than those for the 101st ABD, but higher than those for the 3/2 SBCT. Also, the 1/25 SBCT casualty rate per soldier was higher than for the 101st ABD, unless the casualties suffered in the Mosul mess hall bombing are excluded.²⁶ Below we examine why the per-soldier casualty rate was higher for the 1/25 SBCT than for the other units.

Figure 5.2 above illustrated how insurgent attacks—both across Iraq and in AO North—grew significantly over time. U.S. military responses grew significantly, as

²⁵ Undoubtedly some Iraqi leaders were killed or wounded during the tenure of the 1/25 SBCT. However, we found no press reports from reputable news organizations indicating that high-level Iraqi leaders in Mosul were killed during this time.

²⁶ In December 2005, a suicide bomber was able to gain entry to a forward operating base of the 1/25 SBCT in Mosul. He detonated his bomb in the mess hall, causing 14 U.S. KIA and 51 WIA.

Table 5.7
Casualty Rates for the 101st ABD and 3/2 SBCT

	101st ABD ^a	3/2 SBCT ^b	1/25 SBCT ^b
KIA	47 ^c 30 ^c	11	32 ^d 18 ^e
WIA	271	113	117
Non-hostile deaths	14	10	?
KIA (monthly average)	5.2 3.3 ^c	0.85	2.7 1.5 ^e
KIA (monthly average per 1,000 soldiers)	~0.31 ~0.19 ^c	~0.17	~0.53 ~0.3 ^e

^a May 2003–January 2004 (22 January 2004 was transfer of authority date between units).

^b October 2003–October 2004 or October 2004–October 2005.

^c Two 101st ABD helicopters collided in midair—resulting in 17 casualties, ruled to be 17 KIAs.

^d Suicide bomber attack at mess hall in Mosul resulted in 14 KIA, 51 WIA in December 2004.

^e Excluding KIAs from mess hall attack.

well. U.S. offensive operations against insurgent forces grew roughly proportionally, although the response of each unit differed.

Figure 5.5 shows that the 1/25 SBCT conducted more offensive operations per enemy attack in Mosul during the stability operations phase of OIF than did the 101st ABD or the 3/2 SBCT—or most other units in Iraq.

Consequently, U.S. casualties by themselves do not tell the whole story. A better measure is one that accounts for enemy attacks and U.S. offensive operations. Using data from the CENTCOM SIGACTs database, we computed the percentage of coalition KIA and WIA casualties per enemy attack (Figure 5.6) and per U.S. offensive operation (Figure 5.7) in both the Mosul AOR and all of Iraq.

Figure 5.5
Offensive Operations per Enemy Attack for the 101st ABD, 3/2 SBCT, and 1/25 SBCT

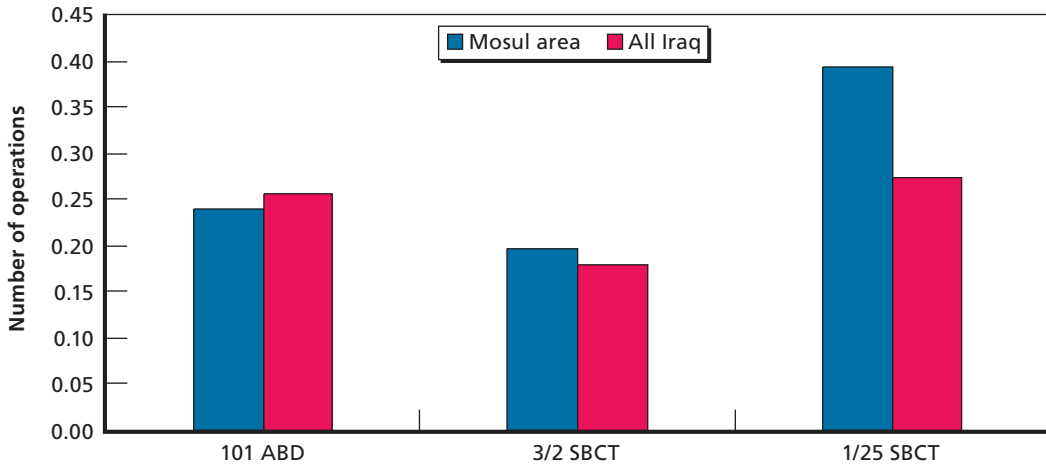

RAND MG593-5.5

Figures 5.6 and 5.7 show order-of-magnitude reductions in casualty rates for both Stryker brigades relative to the 101st ABD and relative to other units in Iraq at the same time, so that operational intensity (both enemy and U.S.) factors can be taken into account. These results reflect the growing intensity of Stryker brigade operations in response to attacks. In this respect, it is significant to note that even taking into account the suicide bombing of the mess hall in Mosul in December 2004, 1/25 SBCT casualty rates (adjusted for OPTEMPO) are the lowest of all units in AO North.

Recall that the analysis of SBCT tactical defensive operations presented in prior chapters of this monograph indicate that the SBCTs' combined materiel (FBCB2 and digital communications) and nonmateriel improvements (doctrine, TTPs, training) led to significant improvements in blue force quality of information

Figure 5.6
U.S. KIA and WIA per Enemy Attack

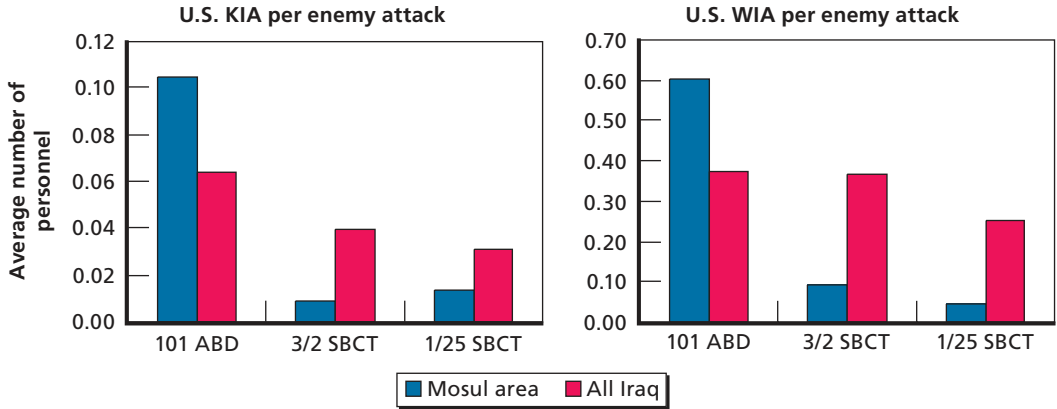

RAND MG593-5.6

Figure 5.7
U.S. KIA and WIA per Offensive Operation

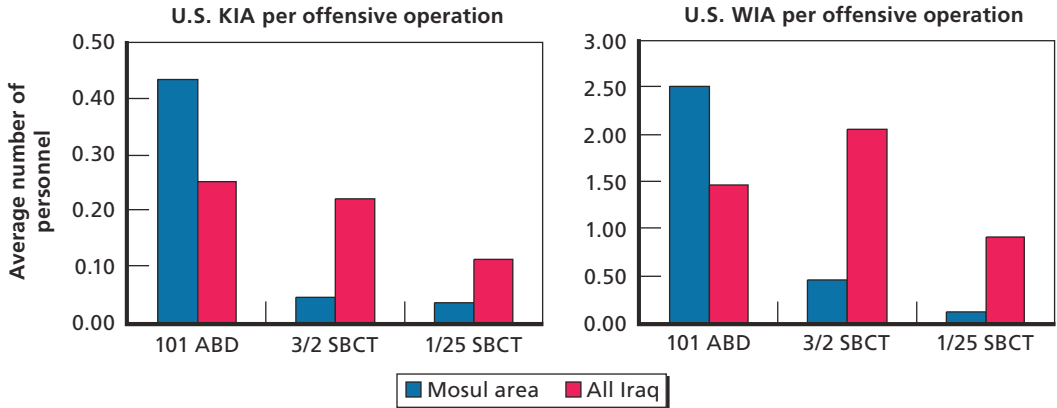

RAND MG593-5.7

and hence to significant improvements in blue force situation awareness and understanding. The SBCTs then capitalized on their improved blue force awareness and understanding to execute a number of advanced tactics, including accelerated planning, dynamic force retasking, self-synchronization, and swarming, which in turn led to improvements in performing tactical defensive missions. The SBCTs displayed a robust dynamic response to enemy ambushes and attacks that was enabled by superior situation awareness, speed of command, and dynamic small-unit synchronization. The 1/25 SBCT also used these advanced tactics, new networked intelligence capabilities, and decentralized operations to conduct targeted raids and “snap” TCPs that kept enemy forces off balance and enabled Stryker units to respond quickly and effectively to intelligence tips. Further, these new intelligence capabilities were integrated into the tactical capabilities of 1/25 SBCT units.²⁷ These operations would not have been possible without the SBCTs’ information and networking capabilities embedded at the tactical level.²⁸

Caveats

When discussing casualties, it is important to take note of the fact that the 3/2 SBCT and 1/25 SBCT are equipped with medium-weight armored vehicles, whereas the 101st ABD is equipped with predominantly soft-skinned ground vehicles. Armored vehicles offer better protection to mounted soldiers against small arms fire, RPGs, and some IEDs. Stryker vehicles in Iraq were also equipped with slat armor, which has proven effective against RPGs. However, only about half of the vehicles of an SBCT are armored Stryker vehicles. The other half are for the most part up-armored HMMWVs similar to those used in light infantry units. Stryker units’ armor gives them a force protection advantage over light infantry brigades, such as those in the 101st ABD. However, many engagements fought by Stryker units were fought dismounted (for example HVT raids and cordon-and-search operations). In addition, insurgents frequently target armored vehicles in IED attacks and design IEDs to maximize their effectiveness against armored vehicles. Insurgents also target logistics convoys, many of which are composed of trucks and other soft-skinned vehicles. Just as in our previous case study on the Stryker brigade (Gonzales et al., 2005a), we recognize that armor is an important factor contributing to mission effectiveness of the Stryker brigade. However, many factors contribute to the success of the Stryker brigade, such

²⁷ See the classified annexes to this monograph for further details.

²⁸ The conclusions we reach here are similar to those identified independently in Kaplan, 2006.

as the Stryker vehicle's mobility and its NCO capabilities. The mobility of the Stryker vehicle also gives the SBCT speed and agility to rapidly respond to changes in the battlespace that are represented in the COP provided by the NCO capabilities of the SBCT. The Stryker vehicle also delivers more firepower than light infantry units typically have, but it is not clear that this firepower was a dominant or even an important factor in many engagements. We do know the vehicle is used effectively as protection against enemy fire. But we could not isolate the observed increase in force effectiveness and force protection as due to a single variable—armor or the capabilities of the Stryker information network. With the data available, it is not possible to quantify the contribution of the information component of the units to the overall force effectiveness of the SBCT. Thus, we attribute this improvement to the entire NCO-based mission capabilities package (MCP).²⁹

An additional caveat is important to consider when comparing the casualty figures mentioned above. The 101st ABD was the first unit involved in stability operations in Iraq; the subsequent SBCT units benefited from prior units' experiences. It is not possible to isolate and quantify how improvements and resulting improvements to TTPs contributed to mission effectiveness.³⁰ Nonetheless, given that the new tactics described above all helped reduce the SBCTs' vulnerability to enemy attacks, we believe that NCO capabilities were important contributors to the SBCTs' reduced casualty rates because many of these new TTPs were enabled by the NCO capabilities of the SBCT and related new intelligence networking capabilities.³¹

Effectiveness of Enemy Attacks

During the tenure of the 101st ABD, insurgents did not target civilians and instead predominantly attacked U.S. forces. The U.S. casualty data above indicate that the 101st ABD suffered a relatively high casualty rate during its tenure in northern Iraq. Insurgent attacks were relatively effective from an enemy standpoint, as indicated in Figure 5.6. During the rotation of the 3/2 SBCT, insurgent attacks shifted from coalition forces to civilians; civilian casualties increased significantly, whereas U.S. casualty

²⁹ Alberts, 1995.

³⁰ It has also been suggested that the SBCT's mission effectiveness may have been partly due to the "Hawthorne Effect": SBCT soldiers performed better because they knew they were being entrusted with a new, "flagship" unit for the Army and would be closely observed. We have no reason to believe that this is true, but we cannot discount this hypothesis entirely.

³¹ See the classified annexes for further details.

rates were considerably reduced from the prior period. In contrast, during the rotation of the 1/25 SBCT, insurgent attacks were significantly less effective. When enemy or U.S. unit OPTEMPO is taken into account, we see that civilian casualties were considerably reduced and U.S. casualties in Mosul were significantly lower than during the rotations of the 101st ABD and the 3/2 SBCT (Figures 5.6 and 5.7).

Control of City Access Points

During the rotations of the 101st ABD and the 3/2 SBCT, coalition forces did not have good control of access points leading to or from the city of Mosul. Consequently, they could not isolate the populace from insurgents and foreign fighters from other countries or other parts of Iraq. Insurgents in the city were reinforced and supplied as needed. As described earlier, the 3/2 SBCT with supporting engineering units constructed a large berm around the entire city of Mosul, which could not be crossed by civilian vehicles. The berm was placed under surveillance, thus enabling coalition forces to detect attempts by insurgents to tunnel through it. When such insurgent operations were detected, the participants were in many cases captured and interrogated.

Figure 5.8 shows the number of the IEDs and weapons caches found in all of Iraq as well as in Mosul. These data show that the number of weapons found in all of Iraq increased significantly over time, while in the Mosul area the greatest number of weapons was found during the rotation of the 3/2 SBCT, before the Mosul berm was built. Overall, the 3/2 SBCT found more weapons than either of the two units that were operating in northern Iraq, whereas the 1/25 SBCT found significantly less than other units in Iraq during the same period. It is possible that the Mosul berm reduced the number of weapons in Mosul during this time—which could be another reason insurgent attacks were less effective during the rotation of the 1/25 SBCT.

Effectiveness of Coalition Security Operations

Our review of coalition operations includes military counterinsurgency operations and reconstruction activities. The military operations we consider are raids and sweeps to capture insurgents and HVTs and access control operations.

The discussion above indicates that the 1/25 SBCT was able to carry out access control operations much more effectively than the other units because of the Mosul berm and also because it could respond rapidly by means of its tactical network when insurgents were detected trying to tunnel through the berm.

Figure 5.8
Number of IEDs and Weapons Caches Found per Enemy Attack for the 101st ABD, 3/2 SBCT, and 1/25 SBCT

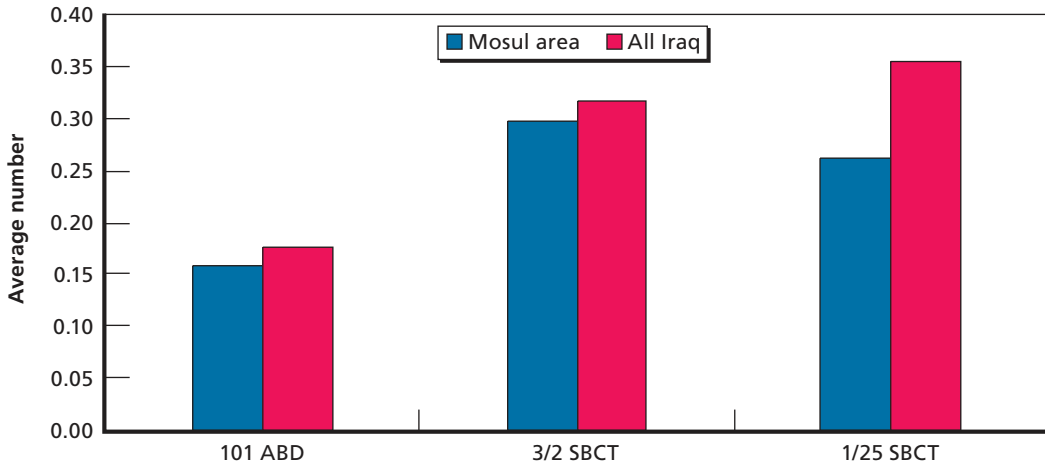

RAND MG593-5.8

Earlier in this monograph, we presented evidence showing that both the 101st ABD and the 1/25 SBCT carried out targeted raids almost exclusively during their rotations. In contrast, the 3/2 SBCT carried out a significant number of sweeps through the neighborhoods of Mosul that likely generated hostility toward coalition forces and the local government. Also, the incomplete but substantial data we collected in this study indicate the 3/2 SBCT was relatively less effective in capturing insurgent leaders in Mosul compared with the other two units. The most effective unit in capturing insurgent leaders was 1/25 SBCT.

This is also consistent with the 1/25 SBCT commander's out-brief, in which he noted the elimination or capture of the top two levels of the insurgent leadership of the Mosul offensive. He stated,

One of the great pieces of information we got recently is 80 percent of the al Qaeda network in the north has been devastated. And those are not our figures, those came from the last six leaders in Mosul, al Qaeda leaders that we captured.³²

³² COL Robert B. Brown, video teleconference, 2005. See also the classified annexes to this report for an MNF-I intelligence assessment of counterinsurgency progress in northern Iraq.

The analysis presented in earlier chapters and in the classified addendum to this report indicates that this resulted from the networking and intelligence capabilities that only the 1/25 SBCT possessed.

The extent and effectiveness of reconstruction operations present a much different story. Here the 101st ABD excelled. As noted previously, it had substantially more resources for reconstruction (funding and engineering battalions) than did the other two units. Nevertheless, a substantial amount of reconstruction activity was completed during the tenure of the 1/25 SBCT. These reconstruction accomplishments were cited by President Bush.³³

Summary of Mission Effectiveness

Table 5.8 summarizes each unit's performance in stability operations in Iraq, along the major performance dimensions described.

Of the performance dimensions above, the 1/25 SBCT's defeat of the insurgent offensive in Mosul, the capture of insurgent leadership in Mosul, and the order-of-magnitude reduction in casualty rates are the most striking. As mentioned previously, some of the improved performance is likely due to protection and mobility afforded by the Stryker vehicles as well as to a general gaining of experience in stability operations throughout MNF-I. At the same time, the discussion in Chapter Four indicates the NCO-enabled tactics led to significant increases in the SBCTs' speed and agility of command, responsiveness of maneuver, and robustness against enemy attacks—all of which are key contributors to defeating insurgent attacks and reducing casualties. We assess the 1/25 SBCT as performing markedly better than the other two units in conducting the security aspects (law enforcement and counterinsurgency) of stability operations. We attribute this performance advantage to the NCO capabilities of the 1/25 SBCT, the TTPs it employed, the training its soldiers received prior to deployment, and its networked intelligence capabilities.

We assess the 101st ABD and 1/25 SBCT as performing better on the political dimensions of stability operations. The 3/2 SBCT did not perform as well as the

³³ U.S. Department of State, "‘Quiet, Steady Progress’ Occurring in Iraq, Bush Says," December 7, 2005.

Table 5.8
Mission Effectiveness Assessment Summary

Dimension	Unit	Observed Performance
Political	101st ABD	Established a functioning multiethnic regional council and held local elections Evident popular support for government and coalition Mosul police department collapse precipitated by CPA actions
	3/2 SBCT	Regional council collapsed or became inactive Mosul police department collapse Reduced support for government and coalition
	1/25 SBCT	Reestablished a functioning multiethnic regional council and provided security to help ensure successful elections in AO North. Increasing popular support for local government and coalition
Security— defeating terrorists/ containing the insurgency, U.S. casualties	101st ABD	Moderately effective at capturing some insurgent leaders, not effective at controlling access to the city, insurgent attacks increased, but level remained relatively low Civilian casualties low, but U.S. casualty rates high Some key Iraqi leaders killed or wounded
	3/2 SBCT	Relatively ineffective at capturing insurgent leaders, not effective at controlling access to the city, insurgent attacks increased Civilian casualties high and U.S. casualty rates low (order of magnitude reduction in casualties per enemy attack or U.S. operation) Several key Iraqi leaders killed
	1/25 SBCT	Defeated a major insurgent offensive to capture Mosul Most effective at capturing insurgent leaders Controlled access to Mosul Insurgent attacks remained high, but decreased slightly over rotation and became less effective Reduced civilian KIA to pre-June 2004 levels An order of magnitude reduction in casualties per enemy attack or U.S. operation

other two units for a combination of reasons: frequent and substantial out-of-area operations that reduced force presence and understanding of local conditions, TTPs not well suited for stability operations, and an apparent reduced emphasis on social networking.³⁴

³⁴ The apparent de-emphasis of social networking with Iraqi civilians by the 3/2 SBCT has been confirmed by other Army unit commanders. This view may have been prevalent with Army commanders during this stage of OIF and appears to have changed throughout the Army since then.

One reason for the superior performance of the 101st ABD and the 1/25 SBCT appears to be their emphasis on social networking—an element of NCO theory. However, the 101st ABD appears to have performed much better than the other units in this area because of the larger number of liaisons and facilitators (MPs, chaplains, and military unit commanders) it possessed. Equally important in winning the “hearts and minds” of the local leaders and populace were the large reconstruction projects the 101st ABD was able to undertake and complete because of the large amount of CERP funds it had at its disposal.

Contribution of NCO Capabilities to Mission Effectiveness

We now consider some of the factors we believe contributed to the unit stability effectiveness results we described above. Figure 5.9 diagrams the linkages we have identified throughout this study among NCO capabilities, tactical stability operations, and the strategic goals of stability operations. The linkages highlight the capabilities these units possessed and the various outcomes that may have been enabled by enhanced NCO capabilities or other materiel or nonmateriel capabilities of the units.

On the far left of the figure are NCO and other materiel and nonmateriel capabilities that can improve tactical stability mission performance. The linkages among capabilities, missions, and stability goals are indicated by color-coded arrows. The effects of organizational capabilities are indicated by green arrows. For example, if a military unit is augmented with additional engineering battalions, it can accomplish more reconstruction tasks, which in turn can contribute to economic development. Or, if it is given more MPs, it can improve liaison support and training of Iraqi security forces, which in turn can contribute to accomplishing the third stability goal indicated on the far right of the figure—employing Iraqi security forces.

The effects of NCO systems and tactical stability missions that we have shown to be enabled by NCO capabilities are indicated by red arrows. For example, our analysis of several types of tactical security operations indicates that NCO capabilities can improve performance of such tactical missions as HVT raids, snap TCPs, patrols, and ad hoc defensive operations, which we have called robust response to enemy attack. As the 1/25 SBCT demonstrated, precisely targeted raids are more effective at capturing insurgent leaders and have fewer undesirable side effects in terms of negative influences on the population than cordon-and-search sweeps, which can disrupt entire neighborhoods and make enemies of ordinary Iraqi citizens.

Figure 5.9
Influence of Network-Enabled Capabilities on Stability Operations

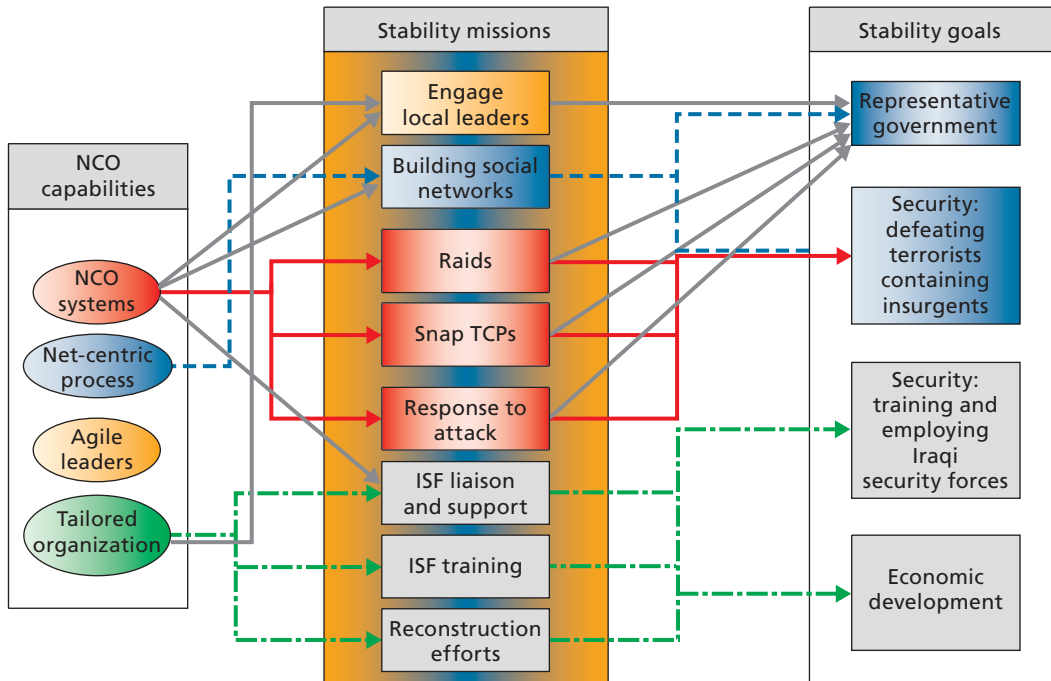

RAND MG593-5.9

We do not include large-scale sweeps as a mission or tactic in the figure. If large-scale sweeps are conducted with excessive force, the result can be considerable property destruction, population displacement, civilian casualties, and resentment toward U.S. forces. Such sweeps are neither enabled by nor dependent on NCO capabilities, and they do not on balance contribute positively toward the accomplishment of stability operations goals.

Improved performance in tactical security operations can potentially help achieve the political goals of stability operations if these missions succeed in eliminating insurgents and demonstrably increase the security and safety of the populace. As the figure suggests, many NCO-enabled tactical missions can contribute to accomplishing the second stability goal (defeat of terrorists and containment of the insurgency). Successful targeted raids and other HVT operations that eliminate insurgent leadership,

as well as patrols or snap TCPs that can prevent insurgent attacks or minimize their destructive power, all contribute to this security goal. This specific goal is central to stability operations and contributes to the achievement of all the stability goals shown.

Equally important in stability operations is achieving the support and involvement of different Iraqi ethnic groups in governance and political processes. In order to reach this objective, specifically to establish a representative or democratic government in Iraq, leaders have to be effectively engaged. U.S. forces have to build social networks among the Iraqi populace to ensure they know who these local leaders are and are able to gain access to them personally. In addition, the Iraqi populace must be convinced that it is safe to go to the polls during elections. As mentioned earlier, the commanders of the 101st ABD did an excellent job of social networking and had agile leadership to accomplish this. This resulted in the quick formation of a representative local provisional government in northern Iraq during the tenure of the 101st ABD.³⁵ Note that we do not use arrows to indicate the influence of agile leadership on any of the missions or goals. In our view, agile leadership influences all missions and the accomplishment of all goals. The figure would become too cluttered if we should this. Nevertheless, agile leadership is an important influence on the success of many missions.

The methods and effects used to achieve U.S. security and political goals in Iraq are closely linked. Enhanced security can enable political progress, and a lack of security can prevent it. For example in 2005 and 2006, insurgent groups threatened Iraqi citizens with death if they dared to vote in the major Iraqi elections. As a result, low voter turnout would have indicated that Iraqi citizens did not have faith in the governance processes established by the United States and perhaps would have supported the insurgency instead. However, successful security operations conducted by U.S. and Iraqi forces enabled more Iraqis to vote, which is an indication of faith and support of the U.S.-facilitated governance process and, more broadly, for a democratic government in Iraq. These important indirect linkages for which we do not have quantitative assessment information are indicated by the gray arrows in the figure.

We are not suggesting that network-centric operations provide the only or even the primary capability that increases unit effectiveness in stability missions. It is not possible to isolate all the external and organic factors that contribute to overall mission

³⁵ The provincial government of Ninawah province later collapsed during the tenure of the 3/2 SBCT, for several possible reasons. A lack of engagement by 3/2 SBCT leaders at that time probably contributed to the collapse. Also, ethnic tensions increased among different groups in Northern Iraq then, especially when the suffering of Sunnis in Fallujah became apparent to TV viewers throughout Iraq and the Middle East.

effectiveness or to ascribe what percentage each factor contributed to the total. We do believe, however, that the analysis of tactical stability operations earlier in this report shows that NCO capabilities can play a significant role in increasing the likelihood of tactical mission success. While we cannot precisely demonstrate cause and effect for each contributing factor, the assessment framework introduced in Chapter One can be used to identify the important external and organic factors that contributed to overall mission effectiveness for the military units analyzed in this case study.

Summary: Findings and Recommendations

In this study, we have examined stability operations conducted by three units responsible for northern Iraq from May 2003 to November 2005: the 101st Airborne Division, the 3/2 Stryker brigade combat team, and the 1/25 Stryker brigade combat team.

Each unit encountered unique external factors during its rotation that were beyond its control. Each unit also encountered insurgent and terrorist threats that changed significantly over time. And each unit laid a foundation for its successors that included intelligence on local threats; contacts with local leaders, politicians and security officials; promises and agreements with them; and a level of trust in coalition forces by the local populace. Because of these “inheritances,” it is not possible to cleanly separate the performance of one unit from another. And of course the enemy “has a vote” and affects any such assessment of unit performance. We consider these to be external factors, which we take into account as best we can in the assessments of unit performance given below.

Assessment of 101st ABD Mission Effectiveness in Stability Operations

Figure 6.1 summarizes the materiel and nonmateriel factors contributing to the performance of the 101st ABD in Iraq. From a networking technology perspective, the 101st ABD benefited from having FBCB2-BFT systems on some of its C2 vehicles and many of its helicopters (68 ground systems and 88 aviation systems).¹ The rest of its

¹ CAPT James Conatser and CAPT Thane St. Clair, “Blue Force Tracking—Combat Proven,” *Armor*, September–October 2003.

Figure 6.1
Key Factors Influencing 101st ABD Performance in Stability Operations

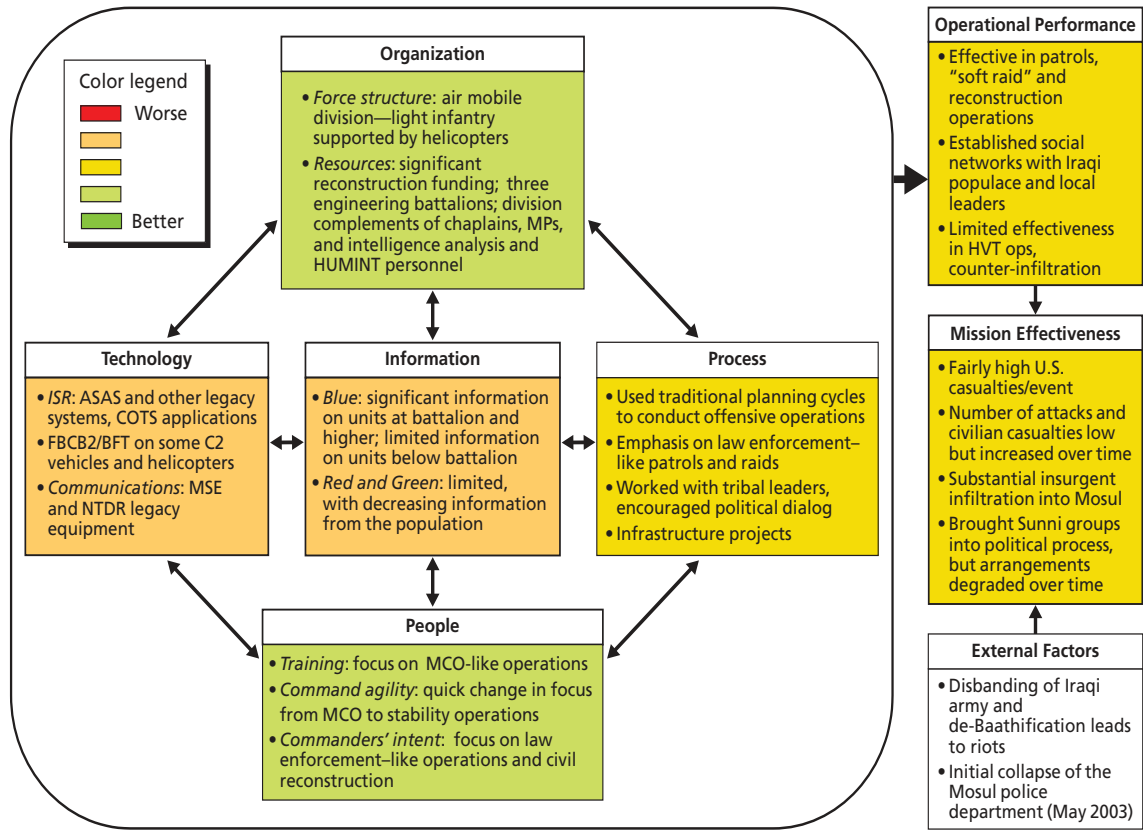

RAND MG593-6.1

systems were the Army's standard issue—MSE and NTDR legacy communications equipment, and ASAS and other legacy systems for ISR.

From an organizational perspective, the 101st ABD is an air-mobile division, comprising light infantry supported by helicopters, with about 17,000 troops total. In comparison, the Iraqi province in which they operated most heavily, Ninawah, has a population of about 2.5 million² (with Mosul having a population of about 1.8 million)³ for a total force ratio of about 6.8 soldiers per 1,000 residents, which is far below the level historically needed for stability operations.⁴ Note that this force ratio does not include security forces that were hired, equipped, and trained by U.S. forces (regional police and new Iraqi Army forces). We do not include these forces in the force presence ratio for several reasons: Their numbers could not be accurately ascertained, these numbers changed significantly from month to month, and their reliability and experience varied significantly depending upon the unit and the time in question.

The 101st ABD also had more than \$31 million in reconstruction funding available, along with three engineering battalions to support reconstruction activities. The unit also had division-sized groups of chaplains and MPs available for liaison activities and a division complement of intelligence personnel, including tactical HUMINT teams.

The 101st ABD's pre-OIF training focused on major combat operations. However, once MCO were over and reconstruction began, the commander's intent rapidly switched to a focus on civil reconstruction and conducting law enforcement-like operations to provide security. Consequently, even though the unit as a whole had not trained for stability operations, the commanders of the 101st ABD were able to reorient their soldiers to conduct stability operations relatively well, without excessive use of combat power and without generating large-scale animosity among the populace.

The reorientation of the 101st ABD included stability-specific processes that emphasized law enforcement-like patrols and "soft" raids (for example, knocking on doors rather than barging into homes) and heavy spending on reconstruction projects performed by local contractors.⁵ In addition, there was substantial command emphasis

² Multi-National Force–Iraq, "Ninawa," 2006.

³ *Encyclopedia Britannica Online*, "Mosul," 2007.

⁴ Quinlivan, 1995.

⁵ Petraeus, 2006, p. 1.

on social networking with tribal leaders, making good use of reconstruction funding and projects to bring Sunni groups into the political dialog.

Many security operations, however, had to be conducted using lengthy (usually day-long) planning cycles, because 101st ABD leaders had to arrange face-to-face meetings to conduct planning. This was necessary because 101st ABD leaders could not reliably communicate with each other over extended distances when in the field. The division also had only limited voice combat net radio systems to monitor operations and respond dynamically.

From an information perspective, the 101st ABD's FBCB2-BFT systems provided significant information on units at the battalion level and higher. However, the 101st ABD had very limited real-time information on units below battalion level. Stability and counterinsurgency operations have been characterized as small-unit operations—company and below. The 101st ABD also had limited information on enemy forces and the civilian population. It had limited tools to collect and analyze intelligence, and the flow of information from the population appears to have decreased over time as population groups (notably Sunnis) became more hostile to the occupation.

Considering performance, the 101st ABD did well in conducting reconstruction and some types of security operations. It was reportedly effective in conducting distributed patrols and “soft raids” and in initially building social networks with the population. However, counter-infiltration raids against adaptive and mobile insurgent leaders were less effective.

Considering effectiveness, the 101st ABD did have a high number of U.S. casualties per attack or coalition operations event, but many local Sunnis were brought into the political process and a local multiethnic governing council was formed. From a stability perspective, the number of enemy attacks and civilian casualties remained low during the 101st ABD's deployment but steadily increased over time. As time went on, there was substantial insurgent infiltration into Mosul. Further, while Sunni groups initially took an active part in the political process, this cooperation lessened. The major external factors further hampering the 101st ABD's effectiveness were the CPA's disbanding of the Iraqi Army and widespread de-Ba'athification. These decisions triggered riots and the first collapse of the Mosul police department in May 2003. The repercussions from coalition force operations in Fallujah, especially from Arab media accounts of what happened there in the summer and fall of 2004, also degraded Sunni participation.

Assessment of 3/2 SBCT Mission Effectiveness in Stability Operations

Figure 6.2 summarizes the factors contributing to the performance of the 3/2 SBCT in Iraq. From a technology perspective, the 3/2 SBCT enjoyed several significant advantages over the 101st ABD. It had FBCB2-EPLRS installed on most platforms, allowing visibility and messaging with most tactical units. It also had a high-bandwidth SATCOM network, IKSS, to provide communications between the brigade's battalion-level units and higher headquarters.

From an organizational perspective, however, the 3/2 SBCT had many fewer resources. Its structure is similar to an infantry brigade, with the addition of a RSTA squadron and MI company, with about 5,000 troops total. With respect to Ninawah province, this meant the force ratio decreased to about two soldiers per 1,000 residents, which is far below the level historically needed for stability operations against an active insurgency.⁶ This ratio was further worsened by the fact that the 3/2 SBCT was MNC-I's reserve force of choice, and MNC-I frequently asked company- or battalion-size task forces drawn from the 3/2 SBCT to conduct operations outside of northern Iraq. The 3/2 SBCT also had many fewer MPs, chaplains, and engineers available than the 101st ABD and many fewer intelligence analysts than a full division.

The 3/2 SBCT had many fewer financial resources than the 101st ABD. It was given only a brigade-size slice of reconstruction funding. By the time the 3/2 SBCT was deployed to the theater, the CPA controlled nearly all reconstruction funding. The CPA was reportedly very slow to disburse reconstruction funds. This, combined with reduced funding for the 3/2, resulted in the suspension or cancellation of many promised reconstruction projects. Some funding was eventually restored, and by the end of the rotation, the 3/2 reported distributing over \$15 million in reconstruction funds,⁷ but this amount is still less than half of what it was under the 101st ABD (\$6,000 per thousand residents versus \$12,400). From a people and process perspective, the 3/2 SBCT utilized MCO-like operations frequently in stability operations. It used advanced tactics when conducting MCO-like operations, including accelerated planning cycles for conducting offensive operations. When deployed in out-of-area operations in central and southern Iraq, the 3/2 SBCT used its high-density FBCB2 network to conduct

⁶ This force ratio does not include ISF. We do not include these forces in the force presence ratio because of reasons cited earlier.

⁷ Rounds, 2004.

Figure 6.2
Key Factors Influencing 3/2 SBCT Performance in Stability Operations

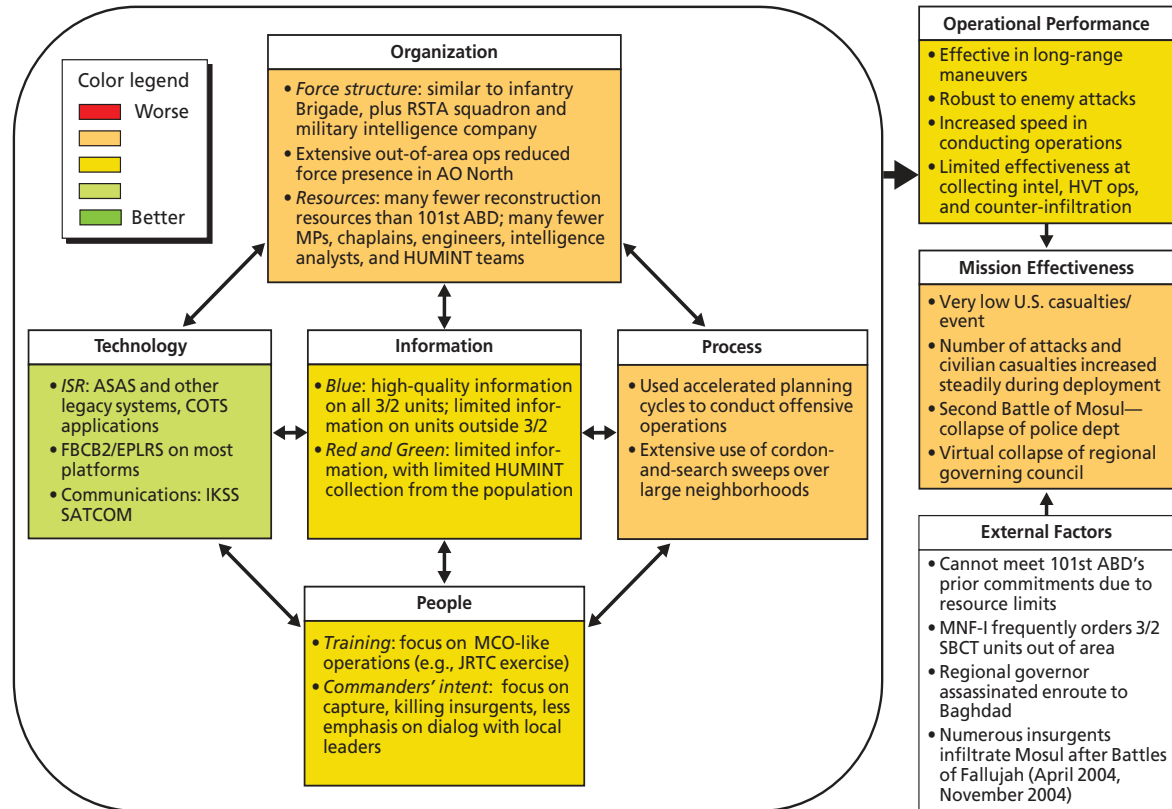

RAND MG593-6.2

dynamic C2 of operations for adaptive maneuver. However, from a stability-specific operations perspective, the 3/2 SBCT's heavy emphasis on MCO-like operations, including frequent neighborhood sweeps, did not help relations with the local population.

From an information perspective, the 3/2 SBCT had significant information on all units within the brigade down to the tactical level, although it continued to have limited information on units outside the 3/2 SBCT. Information on enemy forces and the civilian population continued to be low, with limited information collected from the population.

Considering performance, the 3/2 SBCT did well in MCO-like operations when they were needed, including long-range maneuvers for out-of-area operations, accelerating cycle times for conducting offensive operations, and responding effectively to enemy attacks. However, the 3/2 SBCT's limited effectiveness at collecting intelligence from the population hampered efforts to conduct counter-infiltration and targeted HVT operations or raids. In addition, the many cordon-and-search sweep operations of Mosul neighborhoods appear to have been counterproductive and likely generated considerable resentment and distrust of coalition forces.

Consequently, we assess that the 3/2 SBCT did well with respect to such key MCO measures of effectiveness as casualties—it had extremely low U.S. casualties per event. However, with respect to security objectives for stability operations, the number of attacks and civilian casualties increased steadily throughout the deployment, culminating in the collapse of local police forces in Mosul shortly after the 3/2 SBCT's deployment (November 2004) and in the de facto collapse of the regional governing council earlier in 2004. The 3/2 SBCT's effectiveness was also dramatically hampered by two external factors. First, the 101st ABD had made many commitments in terms of reconstruction projects to local residents and leaders; without the 101st ABD's resources, the 3/2 SBCT could not honor these commitments, leading to significant resentment. Second, the first and second battles of Fallujah in 2004 strongly degraded security in Mosul because of Sunni outrage at the battles and the perceived treatment of Sunni civilians in Fallujah and because of the thousands of insurgents who fled Fallujah and set up operations in Mosul.

Assessment of 1/25 SBCT Mission Effectiveness in Stability Operations

Figure 6.3 summarizes the factors contributing to the 1/25 SBCT's performance in stability operations. From a technology perspective, the 1/25 SBCT began with the 3/2 SBCT's complement of FBCB2 and IKSS SATCOM and added several improvements.

For ISR, the unit had new SIGINT equipment and Rover III/IV systems, providing a video link between air platforms and ground commanders. For communications, the unit added "TeamSpeak" voice-over-IP conferencing, which allowed all battalion-level units to participate in commanders' conferences. The 1/25 SBCT was also augmented with new networked SIGINT capabilities.

From an organizational perspective, the 1/25 SBCT also had many fewer troops than the 101st ABD and lacked the division's reconstruction resources; however, it was not stretched as thin as the 3/2 SBCT. The 1/25 SBCT conducted few out-of-area operations, and substantial portions of another unit, the 3rd ACR, operated in Tal Afar and provided security along the Iraqi-Syrian border in Ninawah province during the latter half of the 1/25 SBCT's deployment, thus enabling the 1/25 SBCT to focus on Mosul and surrounding towns. This meant that the force presence ratio in Ninawah province improved from about two soldiers per thousand residents at the beginning of the 1/25 SBCT's rotation to about four soldiers per thousand residents at the end of its rotation. However, because the majority of the population of the province lives in Mosul, the 1/25 SBCT force presence ratio in the city was still about 2.8 soldiers per thousand residents.⁸

From a people perspective, both training and commanders' intent focused heavily on stability operations. Unlike the other two units, the 1/25 SBCT benefited from stability operations training in the United States prior to deployment. Like the 101st ABD, the 1/25 SBCT processes emphasized social networking tactics to engage the civilian population. The 1/25 SBCT used distributed, law enforcement-like operations, with the dynamic C2 of these operations aided by FBCB2. The 1/25 SBCT developed additional counter-infiltration processes, such as extensive use of randomized checkpoint operations ("snap" TCPs), constructed a berm around the entire city of Mosul, and provided real-time surveillance of it to capture insurgents attempting to infiltrate the city. In addition, the 1/25 SBCT retained the 3/2 SBCT's accelerated

⁸ This force ratio does not include ISF. We do not include these forces in the force presence ratio for the reasons cited earlier.

Figure 6.3
Key Factors Influencing 1/25 SBCT Performance in Stability Operations

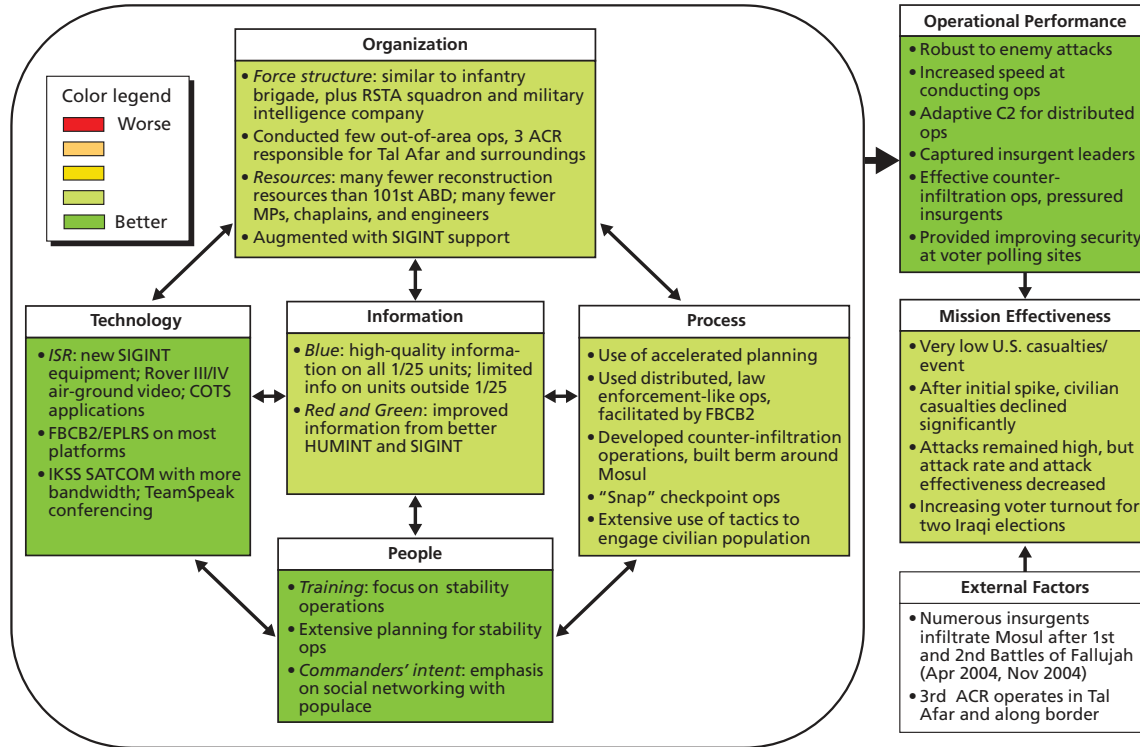

RAND MG593-6.3

planning and dynamic C2 capabilities, which were judged to be important in minimizing casualties.

From an information perspective, the 1/25 SBCT, like the 3/2 SBCT, had significant information on all 1/25 SBCT units and limited information on units outside the 1/25 SBCT. The 1/25 SBCT did have significantly improved information on enemy forces and the local population, both from a significant increase in HUMINT and tips from the local population and from greatly enhanced SIGINT capabilities.

Considering performance, the 1/25 SBCT did well at the security aspects of stability operations and effectively supported local governance. Like the 3/2 SBCT, the 1/25 SBCT had significantly increased speed at conducting offensive operations, and was robust against enemy attacks. The 1/25 SBCT used its dynamic mobile C2 for conducting distributed small-unit operations and could immediately redirect forces to offensive opportunities without requiring advance planning. The 1/25 SBCT was effective at a variety of HVT and counter-infiltration operations, putting significant pressure on insurgents and capturing two levels of insurgent leadership in Mosul. The 1/25 SBCT also provided improved security at voter polling sites during 2005. Equally important, it helped to reestablish political dialog between different ethnic groups and tribes.

Consequently, with respect to overall mission effectiveness and taking into account the larger and more lethal insurgency present in Iraq at the *start* of the 1/25 SBCT rotation, we assess 1/25 SBCT to be effective at all aspects of stability operations addressed in this study. It contributed positively to political progress by reestablishing a multiethnic regional governing council. After an initial spike, civilian casualties declined significantly, enemy attacks declined by a small amount, and these attacks became much less effective. The 1/25 SBCT defeated a major insurgent offensive to seize Mosul, despite the infiltration of thousands of insurgents into the city after the first and second battles of Fallujah, and provided effective security for two Iraqi elections. Like the 3/2 SBCT, the 1/25 SBCT had very low U.S. casualties per event.

In summary, the 1/25 SBCT significantly improved the security situation in Mosul. Indeed, the experienced war correspondent Robert Kaplan, who traveled with elements of the 1/25 SBCT, wrote that normalcy appeared to be coming to Mosul and the surrounding area:

Mosul is a success story, although the success is relative, partial, and tenuous. The credit for what success there has been belongs to one of the U.S. Army's Stryker brigade combat teams that recently departed Iraq: the 1st Brigade of the 25th Infantry Division,⁹

Role of NCO Capabilities in Improving Force Effectiveness in Stability Operations

Our analysis indicates that command leadership, training, and TTPs, or the processes employed in stability operations, are just as important as networking technologies in improving mission effectiveness.

We found that the 1/25 SBCT and 101st ABD performed the best overall in the stability phase in northern Iraq. The 101st ABD and 1/25 SBCT employed some of the same TTPs that were important in capturing insurgents and, for the 1/25 SBCT, in capturing high-level insurgent leaders. In the case of the 1/25 SBCT, these operations were carried out using digital networking and intelligence systems at the lowest tactical level. The 3/2 SBCT did not perform as well as the 1/25 SBCT, even though it was equipped with some of the same digital networking capabilities. Some of the TTPs the 3/2 SBCT employed, such as sweeps, widened the gulf between coalition forces and the local populace. In some cases these tactics may have caused Iraqi civilians to side with the insurgency. From this we surmise that the benefits of networking technologies can be overridden by TTPs that are counterproductive in stability operations.

Equally important is effective social networking with the local populace and civilian leaders. Again, the 101st ABD and the 1/25 SBCT were most effective in achieving political progress. Commanders of both the 1/25 SBCT and the 101st ABD emphasized social networking. Most social networking with the Iraqi populace and local leadership appears to have been carried out in face-to-face conversations and meetings. Military networking technologies had a minimal role here.

Many external factors, including the availability of reconstruction funds, affected the complex and changing political and security situation in northern Iraq. All three units were subject to such external factors, which were beyond the control of the brigades or divisions in control of northern Iraq. In this regard, the two Stryker brigades

⁹ Kaplan, 2006.

were at a clear disadvantage relative to the 101st ABD because they had less funding for reconstruction and fewer key liaison personnel (MPs and chaplains). In addition, other external factors worsened how coalition forces were perceived by the populace.

Finally, even with the deployment of the 3rd ACR to Ninawah province in the latter part of 2005, the 1/25 SBCT had a force presence ratio of only about 2.8 per thousand residents in Mosul, less than half what the 101st ABD had in the province as a whole. In this regard—"boots on the ground"—the 3/2 SBCT was at the greatest disadvantage of the three units. Nevertheless, given the smaller size of the 1/25 SBCT and the more challenging security environment it inherited from its predecessors in northern Iraq, the performance of the 1/25 SBCT is remarkable.

We cannot quantify and isolate the contribution of organization, process, people, digital networking technology, armor, or external factors to overall military unit mission effectiveness. Nevertheless, the analysis presented in this monograph indicates that NCO capabilities made an important contribution at the tactical level to mission performance in many areas (see Figure 6.4). We argue that when we "integrate," or add the results of these discrete individual tactical operations together, these NCO capabilities can contribute to a significant improvement in mission effectiveness of military units in the security mission component of stability operations.

The importance of NCO capabilities in the stability operations of the 1/25 SBCT has also been noted by Kaplan:

New hardware . . . plays a big role, facilitating a change in the relationships between captains in the field and majors and lieutenant colonels back at battalion headquarters . . . a computer system that gives captains and noncommissioned officers situational awareness and the latest intelligence for many miles around—has helped liberate field units from dependence on headquarters.

Autonomy is further encouraged by the flat "intelligence architecture" of the Stryker brigades. Information now comes to captains less and less from battalion headquarters, and more and more from other junior officers in other battalions, via informal e-mail networks, as well as directly from Iraqi units. The lieutenant colonel who commands an infantry battalion, and the major who is the captain's executive officer, do not always have to be consulted. Given the results, the commanding officers like it that way.¹⁰

¹⁰ Kaplan, 2006.

Figure 6.4
Adaptation of Materiel and Nonmateriel NCO Force Elements

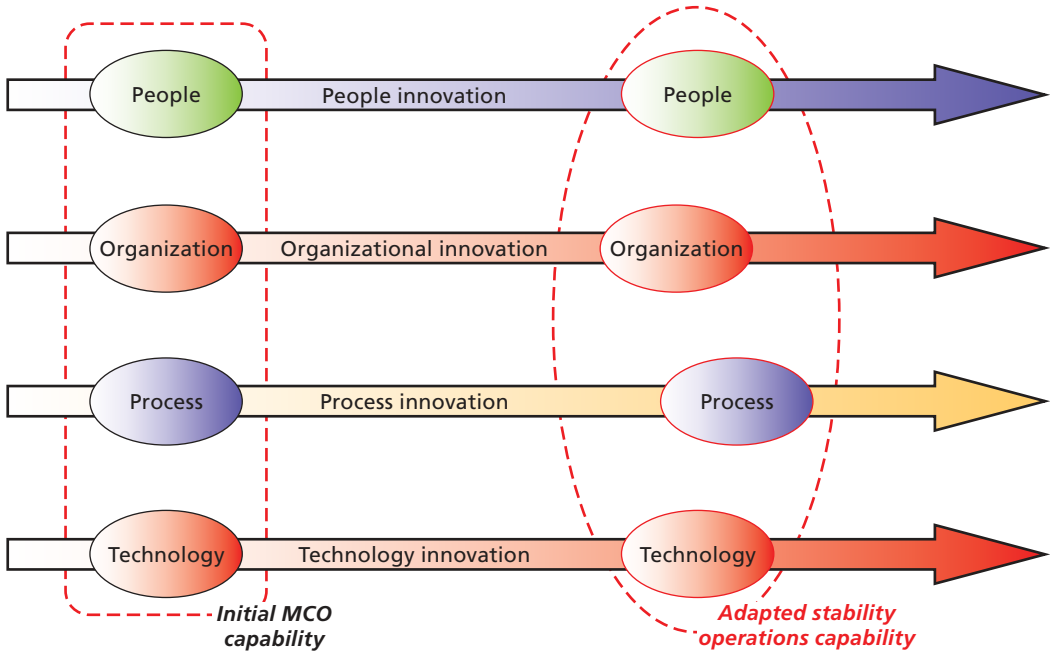

RAND MG593-6.4

Kaplan is describing classic findings in the NCO literature—the ability of networked forces to become more responsive, more adaptive, and able to make effective command decisions at lower levels without waiting for intelligence and other information to flow up to and then down from higher headquarters.¹¹

¹¹ See for example, Alberts et al., 2001, and Alberts and Hayes, 2003. Earlier discussions of flattened decision, production, and supply chain networks can also be found in the reengineering business literature.

Summary of Network and Intelligence Capabilities

A summary of the 101st ABD, 3/2 SBCT, and 1/25 SBCT networks is shown in Table 6.1. There were significant differences among all three networks. The 1/25 SBCT's network was considerably more capable, especially from a joint operations perspective.

Intelligence Capabilities

Intelligence challenges associated with the Iraqi insurgent and terrorist forces required most Army units to employ new intelligence analysis approaches and later tools to analyze the enemy. Many of the intelligence capabilities of the 101st ABD and the 3/2 SBCT were very similar. They both used standard Microsoft Office products to do much of this analysis because Army MCO-focused intelligence tools were less useful for stability operations.

The 1/25 SBCT had additional intelligence capabilities the other two units did not possess, including software tools from the law enforcement community that had been adapted to analyzing insurgent networks. The 1/25 SBCT was also able to make effective use of joint and national ISR capabilities to a much greater extent than could a traditional light infantry brigade. The integration of these ISR sources was made possible by having appropriately trained and cleared personnel at the brigade level and by new system capabilities.¹² While these joint and national ISR sources were not new, their effective integration into tactical operations in real time was. The ability to use the information they generated in real time, using networks, led to significant operational performance improvements, as described in the classified addendum to this report. The additional intelligence capabilities of the 1/25 SBCT and its NCO capabilities enabled it to effectively exploit precise but perishable actionable intelligence.

Caveats

As noted earlier, Stryker brigades are equipped with medium-weight armored vehicles while the 101st ABD is equipped with predominantly soft skinned vehicles. However, only about half the SBCT vehicles are Stryker vehicles. The other half are HMMWVs like those used in light infantry units. Up-armored HMMWVs were distributed to the 3/2 and 1/25 SBCTs but were not available to the 101st ABD in 2003. While this armor protection provided a force protection advantage for the SBCTs relative to the 101st ABD, it should be noted that many Stryker engagements were

¹² A description of these ISR integration capabilities is included in the classified annexes to this report.

Table 6.1
Summary of Networking and Battle Command Enhancements

	101st ABD	3/2 SBCT	1/25 SBCT
FBCB2/BFT on AVN	40 AH-64 30 UH-60 12 CH-47 82 total	On helicopters supporting 3/2	On helicopters supporting 1/25
FBCB2/BFT per infantry brigade on C2 vehicles	5–8	13	13
FBCB2/EPLRS on ground vehicles			
Stryker vehicles	0	317	317
Other vehicles	0	~280	~280
Reliance on MSE/NTDR for brigade–battalion communications	Yes	No	No
IKSS SATCOM terminals	0	10	10
TeamSpeak/SIPRNET for brigade battle update brief	No	No	Yes 50–80 participants
Access to Rover III communications terminals	No	No	Yes Battalion level
Fiber-optic links	No	No	Yes Brigade TOC– battalion TOC– company TOC
PDA's or "CSI Mosul" information	0	0	Some infantry soldiers

 Factor with a relative disadvantage  Factor with a relative advantage

fought dismounted (for example, raids against high-value targets). Furthermore, insurgents frequently targeted armored vehicles in improvised explosive device (IED) attacks and designed IEDs to maximize their effectiveness against armored vehicles. Insurgents also targeted logistics convoys, many of which are composed of trucks and HMMWVs. To counter the IED threat, U.S. forces deployed to Iraq in 2004 and later (including the 3/2 and 1/25 SBCTs but not the 101st ABD) were equipped with electronic counter measures such as Warlock and the IED Countermeasures Equipment (ICE) system. These systems have contributed to increased force protection capability in mounted and dismounted operations throughout Iraq. For these reasons, the difference in casualty rates between the two SBCT units and the 101st ABD is prob-

ably due to multiple factors. However, it is interesting to note that casualty rates for the 3/2 and 1/25 SBCTs are significantly less than other U.S. units that operated in Iraq during the same time periods, when up-armored HMMWVs, Warlock, and ICE systems were available to many if not all U.S. units (see Figures 5.6 and 5.7).

We recognize that armor is an important factor contributing to the mission effectiveness of the Stryker brigade. However, many factors contribute to Stryker brigade effectiveness, such as the Stryker vehicle's mobility and its NCO capabilities. The mobility of the Stryker vehicle provides the SBCT the speed and agility to respond rapidly to changes in the battlespace that are represented in the COP provided through the network. The Stryker vehicle also delivers more firepower than light infantry units typically have. However, it is not clear that this firepower was a dominant or even an important factor in many stability operations. We do know the vehicle is used effectively as protection against enemy fire. In this study it was not possible to attribute the observed increase in force effectiveness and force protection to a single variable—either armor or the capabilities of the Stryker information network.

Additional Findings

We did note two specific challenges and shortcomings.

Ninawah province, with its 2.5 million residents, appears to be too large to be covered by a single brigade. More “boots on the ground” were needed. The 3/2 and 1/25 SBCTs were unable to effectively conduct stability operations throughout Ninawah province without assistance from other units.

It is exceedingly difficult for a military unit to conduct stability operations in one area while being tasked to frequently conduct out-of-area operations. A continuous force presence in Mosul and Tal Afar was difficult to sustain by the 3/2 SBCT because of extensive out-of-area operations. Social networking with local populace and leaders is degraded when commanders and soldiers are not able to “settle down” in a particular neighborhood or town and get to know the local politics and cultural background.

Army Battle Command Systems and Stability Operations

All units encountered significant challenges in using the ABCS at command centers for situation awareness of the enemy and the local population. Traditional “red icons” did not match well to tracking the activities of insurgents. Similarly, ABCS lacked forms or displays suited for tracking developments with the local population (demon-

strations, results of personal contacts, etc.). As a result, much information was transmitted using text messaging and text chat, which could not automatically populate databases and situation awareness screens. Some ABCS systems, notably ASAS and the Maneuver Control System–Heavy, were considered to be unsuitable for stability operations, and were largely not used. The use of FBCB2 text messaging while useful at the tactical level, could also sometimes result in key messages about engagements not being reviewed by personnel at the brigade TOC.

Language and Culture

SBCT soldiers frequently requested additional linguists (linguists who both spoke and wrote Arabic fluently and could be fully trusted were in short supply), even to provide simple open-source intelligence functions such as reading Iraqi media. There were also requests for more language and cultural training.

Recommendations

We recommend several net-centric capability improvements.

Blue Force Tracking (BFT) and Battle Command Systems

- *Field FBCB2, or FBCB2-compatible systems, on a wide scale at the tactical level.* The FBCB2 system was a key enabler of the improved situation awareness, speed of command, and synchronization of SBCT units. The system is deployed widely enough in Stryker units to make it a key capability for SBCT tactical units, not only a tool for senior commanders. We recommend that FBCB2, or FBCB2-compatible systems, be widely deployed at the tactical level throughout Army and USMC units, as well as to key coalition partners such as the United Kingdom and Australia.
- *Add classes to FBCB2, and ensure that messaging a class is the standard when reporting engagements.*
- *Expand FBCB2's preformatted reports to include more stability operations–related reports, and make them easier to use.* Add report templates for demonstrations, suspicious activities, relations between suspects, patrol debriefs, and results of informal and formal meetings.

- *Provide battle command devices or at least BFT devices to dismounted units.* SBCT soldiers requested the auto-population of dismount locations on FBCB2, at least down to the team level.

Red Force and Cultural Awareness

- *Provide a common suite of analysis tools for performing pattern, link, and temporal analysis of tactical stability operations.*
- *Relax procedures for disseminating HUMINT to provide actionable information to those soldiers needing it.*
- *Provide additional training.* Soldiers requested additional training on tactical questioning, processing material collected from operations, and general cultural awareness. They also requested training on civil affairs, languages, information operations, negotiation, and HUMINT.

APPENDIX A

**Director, Office of Force Transformation, Study
Authorization Memorandum**

This memorandum is reproduced on the following two pages.



OFFICE OF THE SECRETARY OF DEFENSE

1000 DEFENSE PENTAGON
WASHINGTON, DC 20301-1000

FORCE TRANSFORMATION
3A287

October 12, 2004

Lieutenant General James J. Lovelace, Jr.
Deputy Chief of Staff, G-3
Headquarters, United States Army
400 Army Pentagon
Washington, DC 20310-0400

Dear General Lovelace:

The Office of Force Transformation is continuing its Network Centric Operations research efforts to gain a greater understanding of the role of information in full-spectrum operations and to assess the implications of network capabilities and shared high-quality information on unit performance. As a result of our collaboration on last year's Stryker Brigade Combat Team (SBCT) Case Study, we have gained significant insights into how networked forces can operate in major combat operations. We would like to exploit the momentum we developed during last year's SBCT case study to explore in depth the application of network enabled capabilities in a Stability and Support Operations (SASO) environment.

I have asked the RAND Corporation National Defense Research Institute (NDRI) to conduct this effort. This study will examine the effects of information advantage and network capabilities in the complex SASO environment, and provide insights that will be useful to the Department's Network Centric Operations implementation initiatives.

To facilitate this study RAND NDRI requires access to interview leaders and selected key soldiers of 3d Bde, 2 ID (SBCT) and 1st Bde, 25th ID (SBCT), as well as after action reports, lessons learned, and other pertinent information collected during mission rehearsal exercises and operational employment. The study will include insights from 3-2 SBCT as they participated in OIF 2, as well as 1-25 SBCT's Mission Rehearsal Exercise at the JRTC this year. A representative list of requested data is attached.

The RAND NDRI research team is available to brief you on the study as well as last year's Stryker Brigade Case Study at your convenience. I will keep you informed on the progress and outcomes of this effort.

Colonel Gary Agron is the project lead. He can be contacted at 703-696-5716 or gary.agron@osd.mil.

Sincerely,

A handwritten signature in black ink, appearing to read "A. K. Cebrowski".

A. K. Cebrowski
Director, Force Transformation

Attachment:
As stated

Document Review to support RAND NDRI study *"Implications of Stryker Brigade Network Centric Operations capabilities in Stability and Support Operations"*

Interviews of Key and Selected Personnel from 3d Bde, 2 ID (SBCT) during OIF 2.

Lessons learned on SASO operations from 3-2 SBCT during OIF 2.

Interviews of Key and Selected Personnel from 1st Bde, 25th ID (SBCT) during JRTC 04-05.

Joint Readiness Training Center products for 1-25 SBCT Mission Rehearsal Exercise (Rotation 04-05)

- Leader Training Program orders and seminars
- Rotation "laydown" briefing and Commander Operations Group IPR's
- Operations Orders, Fragmentary Orders, INTSUMs, and other Mission Rehearsal
- Exercise products provided by JRTC Operations Group to 1-25 SBCT
- 1-25 SBCT written orders, INTSUMs, unit reports, and requests for information produced during the Mission Rehearsal Exercise
- JRTC After Action Review products and "Take Home Packages" prepared for the 1-25 SBCT Mission Rehearsal Exercise

Joint Readiness Training Center products for baseline assessment, 1st Cavalry Division SFOR IV or 10th Mountain Division Mission Rehearsal Exercise (in consultation with the Army one of these units will be selected for comparison to an SBCT)

- Leader Training Program orders and seminars
- Rotation "laydown" briefing and Commander Operations Group IPR's
- Operations Orders, Fragmentary Orders, INTSUMs, and other Mission Rehearsal Exercise products provided by JRTC Operations Group
- Rotational unit written orders, INTSUMs, unit reports, and requests for information produced during the Mission Rehearsal Exercise
- JRTC After Action Review products and "Take Home Packages" prepared for the SFOR IV Mission Rehearsal Exercise

SBCT training and operational products

- Standing Operating Procedures
- Observations, Lessons Learned and After Action Reviews
- Unit Tactics, Techniques, and Procedures (TTPs) for SASO, including but not limited to:
 - Non-lethal effects detachment(s)
 - Information operations functions
 - Civil-military operations functions
 - Security operations functions

Center for Army Lessons Learned products

- CALL embedded LNO reports and observations on SBCT in SASO
- Emerging lesson's learned and TTPs on SBCT in SASO

SBCT Tactics, Techniques, and Procedures Used in OIF

The NCO conceptual framework mentioned in Chapter One suggests that enhanced information quality and shared situation awareness will support the execution of improved TTPs. At the 1/25 SBCT lessons-learned conference, participants reported on a number of new TTPs tailored to the stability operations environment that, at least in part, depended upon improved shared situation awareness and collaboration capabilities. These included both an overall strategy encouraging agility and distributed operations in conducting stability operations and a set of supporting, mission-specific TTPs.

1/25 SBCT Concept and Organization for Conducting Stability Operations

The SBCT leadership and NCO structure aim at providing soldiers and leaders with the equipment and training needed to respond rapidly to the fluid situations that occur in stability operations. The brigade commander encouraged sharing of information, delegated decisionmaking authority to subordinate leadership at the lowest levels, allowed battalions and companies to operate independent of the brigade headquarters, and stabilized units to cover a particular AO for an extended period of time.

The 1/25 SBCT commander taught and enforced these concepts through his leadership philosophy, which he summed up in a leadership handbook entitled *Leaders Agility Book*, which was reported by SBCT members to be the basis for the mission-specific TTPs that were developed and are mentioned in this appendix. The book's cover is shown in Figure B.1.

Figure B.1
Cover of the 1/25 SBCT's Leaders Agility Book

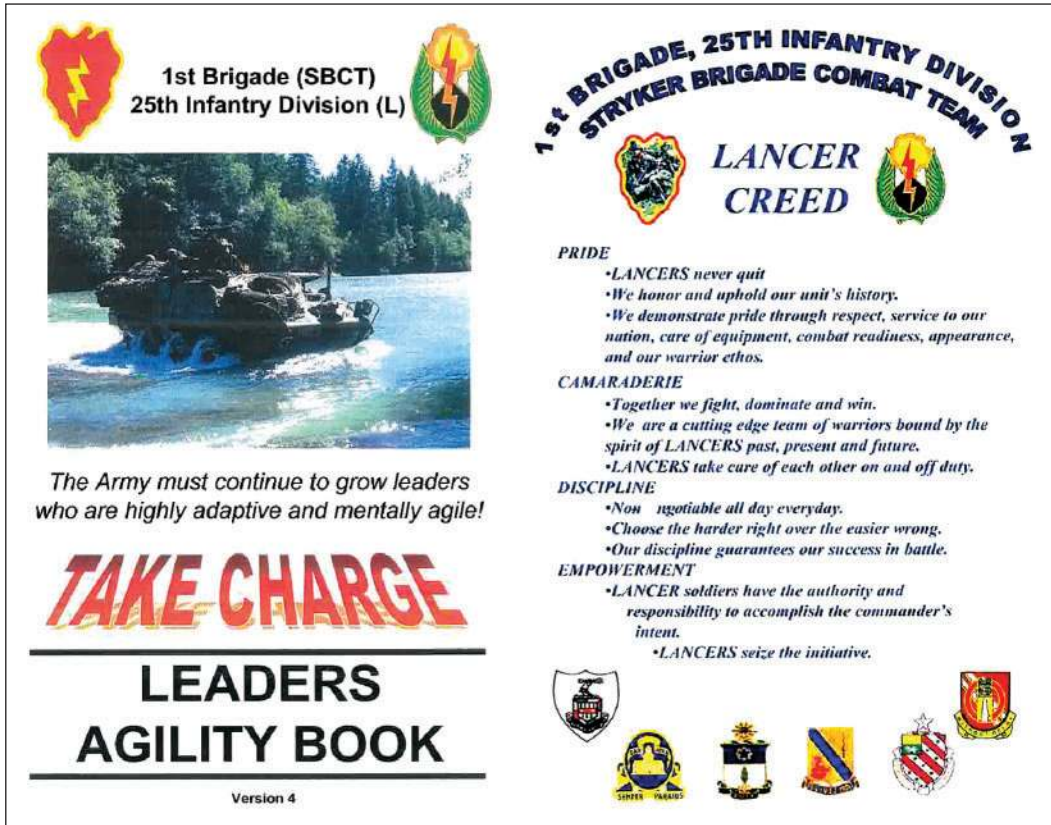

RAND MG593-B.1

On page 1, the commander noted the brigade's success in war would come not from any new equipment or weapon system but from soldiers who can receive a mission and execute it without further guidance. The handbook lists four attributes of an agile leader, and explains and provides vignettes for each attribute, as follows:

1. Be prepared to take charge one to two levels up.
2. Take the initiative.
3. Make educated decisions under stressful conditions.
4. Be able to adapt to the changing situation.

The handbook goes on to discuss why agility training is important, stresses the use of the Army's eight-step decisionmaking model on all problems, and provides agility vignettes and situation training events that could be used for training throughout the unit. The book also notes that its philosophical foundation is to be used as a guide and is "not the final answer to your problems."

Building on the handbook, 1/25 SBCT leadership focused on conducting rapid, parallel planning during steady-state operations and promoting a cooperative information-sharing culture. The brigade leadership directed the brigade to operate in a decentralized manner, with decisionmaking power delegated to the level considered necessary to accomplish a mission. Thus, in many cases battalions operated independent of the brigade, and some companies operated independent of their battalions. Decentralization extended down to the individual soldier: SBCT soldiers commonly reported, as the handbook guidance indicated, that they were expected to be able to make decisions two echelons above them. This decentralized structure was intended to reduce the response times for access to information and allow the brigade to get inside the enemy's decision cycle. This organizational structure, combined with the integration of intelligence and operations, supported the development of a variety of mission specific TTPs in such areas as conducting distributed operations within the AOs, conducting traffic control points, employing aerial support and surveillance platforms, generating and sharing actionable intelligence, IED-handling procedures, and sniper employment procedures.

Conducting Distributed Operations

As noted, 1/25 SBCT units were largely given independent areas of operation. Intelligence and targeting were generally done at the battalion level and lower, and units were largely responsible for creating the "picture" of their own AOR. The use of distributed operations generally extended down to the lowest tactical level, with platoons, squads, and individuals regularly patrolling particular streets, providing the soldiers with a great deal of experience about those streets. A number of 1/25 SBCT soldiers noted that the bulk of key decisions were made at the squad and team level and that it was critical to provide those leaders with information, training, and experience.

Patrols were commonly flexible operations, combining mounted or dismounted visits to the local populace with observation operations. Units were also on call to respond to situations in the local area. Soldiers noted being frequently redirected to

mount an immediate raid in response to an incoming tip, with the information and instructions provided both over the radio and over FBCB2 (which mapped the location of the target). The ability to respond immediately to an incoming tip was regarded as critical. Soldiers reported that they had at most 30–45 minutes to respond to a tip to have any chance of success; conventional 12–24 hour planning cycles were not adequate to meet timeliness requirements.

Conducting Traffic Control Points

The 1/25 SBCT learned quickly that there is no such thing as a routine traffic control point. The insurgents targeted soldiers and civilians where the military set up for a long term. Long-term or permanent traffic TCPs gave the enemy the advantage of knowing when, where, and how long soldiers would be at a certain place. Soldiers developed procedures to fit the changing situation. The new procedure called for quick reaction TCPs known as Flash, Snap, and Deliberate. A Flash point could be set up in seconds and would allow a small number of cars to pass (1 to 10) before moving to a new location. A Snap point would last for around 10 minutes, and a Deliberate one would last for up to an hour. The brigade often used different procedures at different locations. This timed control point technique, along with varying the vehicle flow traffic through the TCP by searching some vehicles thoroughly and just waving others through, proved successful.

1/25 SBCT soldiers reported that the revised TTPs allowed them to get into the adversary's decision cycle. The enemy no longer knew if the soldiers were using TCPs just to confuse them or because they were really looking for an HVT suspected of traveling a particular route. Nor could the enemy tell where, when, why, or for how long soldiers would set up a control point.

Soldiers were also able to use technology to their advantage. One example was tracing cell phone calls. Soldiers monitored civilians who were using cell phones while approaching TCPs. If a cell phone user attempted to avoid the checkpoint, the soldiers traced the cell phone in order to capture and question the individuals who were avoiding them. Technology such as the use of lasers, digital imagery, and criminal investigation systems also provided a physiological advantage in many cases. For example, many Iraqis would not comply when told to stop their vehicle, but when a blue or green laser was placed on them, they stopped their vehicle immediately.

Networking with Aerial Support and Surveillance Assets

The 1/25 SBCT used manned fixed-wing aircraft, UAVs, and manned rotary-wing aircraft in both traditional and nontraditional roles. The U.S. Air Force's (USAF's) manned fixed-wing aircraft were used for CAS throughout the brigade's entire deployment. Early in the deployment, CAS was used heavily in its traditionally lethal role to destroy targets. Later in the deployment, the main use of CAS was in a nonlethal role. The brigade used CAS for observation and surveillance of named areas of interest as well as a show of force. The brigade found that this use of CAS to detect or influence targets using nonlethal means was effective.

OIF became the first major operation where UAVs were employed in mass at the battalion and brigade levels to deliver weapons and provide surveillance data. The U.S. Army and Air Force employed various UAVs with varying results.

The Rover III, discussed in the main body of this document, received high marks from officers and soldiers of the 1/25 SBCT. This system allows viewing of video feeds from over 15 different manned and unmanned sensor platforms with detailed imagery. The Rover III helped the brigade employ CAS; conduct surveillance, including tracking HVT vehicles; and conduct transit route reconnaissance. The terminals are small enough to be mounted in a Stryker vehicle, and the brigade hopes to have this capability in some of its vehicles in the future. The Rover III's image clarity was considered superior to video imagery from other airborne platforms.

The Predator is a medium-altitude, long-endurance UAV belonging to the USAF. Its primary mission is interdiction and conducting armed reconnaissance against critical, perishable targets. The joint force air component commander (JFACC) typically controls and employs this asset for reconnaissance, surveillance, and target acquisition in support of the Joint Forces Commander. When the Predator was flown during the 1/25 SBCT's rotation, the SBCT was able to download its ISR data with the Rover III and use the data for mission planning. The soldiers did note that the Predator's images, like that of other UAVs, were good for identifying vehicles but not detailed enough to identify individuals.

The Raven, a miniature U.S. Army UAV, and the one most accessible by the brigade, received poor ratings. The biggest complaint was its noise level and acoustic signature. It had almost no chance of remaining undetected when on mission. Soldiers used it to draw enemy fire in many situations to detect an enemy's location. Raven was also a deterrent when used by planners to fly future mission and convoy routes. Another issue the soldiers had to overcome with the Raven was the inability to fly the

aircraft. Many of the soldiers had never flown the UAV before and had to learn on the job, which resulted in many crashed UAVs. Once a Raven was down, it took a long time before it was recovered and was ready to fly again due to the limited maintenance contractor support. Although the Raven was noisy, the cultural environment of Iraq made it difficult for any UAV to operate undetected during night reconnaissance as it might in the United States. The reason for this is that throughout the country a large number of civilians can be found walking to the mosque to pray daily as early as 4:00 a.m. The Global Hawk, Shadow, and Pioneer UAVs also periodically provided video data downlinks.

1/25 SBCT soldiers also struggled with describing the video feeds from the battalion tactical operation centers to soldiers on the ground via voice radios. In almost all scenarios, real-time UAV video feeds were not available to the soldiers on the ground.

The aircraft of choice were Army helicopters. Soldiers preferred the OH-58 Kiowa Warrior (a manned reconnaissance helicopter) over a UAV for all missions. Specifically, AWTs and Pink Teams (an Apache accompanied by a Kiowa Warrior) both proved to be combat multipliers. The AWT coverage for convoys was initially hampered by the brigade not having had the opportunity to train with the AWT before deployment. Attack aviation to defend against attacks and to provide aerial surveillance should be used for all convoys traveling dangerous routes or long distances. The unit standard operating procedure (SOP) for requesting AWTs was 72 hours.

Pink Teams provided the best area surveillance and firepower if needed. The soldiers were able to communicate directly with the pilots and receive observation updates. Pink Teams working along with the Strykers were very successful in capturing HVTs during both cordon-and-search and TCP operations. The pilots regularly put themselves in harm's way to protect the soldiers on the ground, giving confidence to the soldiers who knew that help would be there when they needed it. Although the helicopter pilots' excellent situation awareness and immediate firepower provide the best aerial support today, the hope is that in the future UAVs will be able to hover quietly and provide immediate surveillance feedback without putting pilots in harm's way or compromising the ground soldiers' missions.

Generating and Sharing Usable Intelligence

The 1/25 SBCT employed a variety of digital tools to generate usable intelligence. The use of digital imagery and criminal investigation systems like Vapor Trace and the

Biometric Automated Tool Set (BATS) provided soldiers conducting TCPs, cordon-and-search operations, and other missions with both a psychological advantage and reusable intelligence data. This was possible because many Iraqis had never seen digital cameras and soldiers could show them an immediate image of themselves. The Vapor Trace and BATS systems enabled soldiers to fingerprint, take voice recordings and eye scans, and test individuals to see if they had traces of chemicals or gunpowder on their skin. This could tell a soldier if individuals might be partially responsible for building IEDs or if they had been recently firing a weapon. It became standard procedure for every squad on patrol, regardless of the mission type, to carry a digital camera. Pictures, with individual's names, voice recordings, etc., were shared with other units. This enabled the tracking and sharing of information on the adversary that had not been possible in past conflicts before the use of digital cameras, portable forensics tools, and the Internet.

The networking systems on the Stryker vehicles enabled improved TTPs for sharing actionable intelligence. Two examples in which technology enabled sharing intelligence were soldiers' responses to information tips, and the use of the FBCB2 radios for sending fragmentary orders (FRAGOs).

1/25 SBCT soldiers developed a number of TTPs for generating actionable tips. The brigade established a tips hotline number over standard Iraqi phone lines and followed up with an information operation campaign that distributed leaflets, flyers, and pamphlets that warned of the penalties for protecting terrorists and provided assurance that citizens phoning in tips would remain anonymous. The tip line proved extremely useful when combined with the relationships that units had built with Iraqis in the AOR. A hotline tip example is the following: A unit would go to a house from which a tip was called in, but upon arrival would receive a call from the informant saying, "Not here, try the house three doors down to the right." The informant would do this to keep the occupants from seeing soldiers leaving their house to apprehend others in their neighborhood.

Patrols also developed tips. For example, during a cordon-and-search operation, an Iraqi in his home might say, "no insurgents here, but why don't you come into my kitchen for tea?" In the kitchen the soldier would find a card with a cell phone number and call back times written on it. The unit would call back, and the Iraqi would provide intelligence.

As noted, the brigade determined that it had roughly 45 minutes to act on a target from the moment it received a tip, especially on a HVT, or it would be gone. Traditional targeting methods, which generated target packages over days, weeks, and even

months, gave the adversary time to plan ahead of U.S. forces and evade capture. The ability to act on intelligence tips in hours—frequently minutes—was reported as key to the brigade’s successful capture of many high value targets. The information to mount an operation came either from a source or another live intelligence hit, a signals intercept or visual contact. To respond, the units used FRAGOs broadcast over the FBCB2 radios to provide the necessary authorization to act.

Even with short-response decisionmaking tools, the unit was not fast enough to capture many targets, but it did not discard useful intelligence. Instead, it would revisit the same locations of that and previous targets that were known safe houses, working on the assumption that a given HVT would only have access to a limited number of locations. This technique frequently resulted in eventually capturing the HVTs or their associates.

Procedures for Improvised Explosive Devices

Although the brigade conducted frequent route clearance sweeps, IEDs and suicide vehicle-borne improvised explosive devices (SVBIEDs) continued to be a significant problem for the brigade. To mitigate IEDs, the brigade updated an IED density analysis map that displayed trends and patterns for future planning daily. The brigade cited the daily route clearance and status synchronization meetings as critical to conducting secure convoy operations. In addition to extensive mission planning and IED identification training, the brigade also developed new reaction drill procedures for vehicle rollovers, fires, and casualties caused by an IED attack.

First, to mitigate rollovers, soldiers practiced reaction drills daily before leaving their compound as one of many pre-combat checklist items that should be completed before starting patrols. These drills included seeing how fast soldiers exposed in a hatch could drop inside of the vehicle, while wearing the proper headgear and seatbelts, and brace themselves for a rollover. The standard Stryker seatbelt was found to be difficult to disconnect because of the placement of the release button. The seatbelt and vehicle commanders’ helmet communication connector often got snagged on uniforms and equipment, delaying a soldier’s exit from a burning vehicle. The soldiers recommended that the seatbelts be modified to include an easier release latch and be adjustable to fit a soldier and his equipment. Ensuring all items were properly stowed before movement was another way of reducing injuries during a vehicle rollover. In the event of a vehicle fire, the procedure was to roll through the attack or kill zone to a safer area as long as

the vehicle was mobile and troops did not require immediate medical attention. Each Stryker carried two to three fire extinguishers upon arrival to the theater, but within three weeks of their arrival all vehicles carried six or seven extinguishers due to the high number of fires. Soldiers knew once a vehicle started to burn, it would be difficult to stop.

The Stryker vehicles had high survivability when attacked by IEDs and other objects. Rarely was a Stryker unable to move on its own power after an attack, regardless of the number of tires it may have lost. Many times soldiers had to exit the vehicles and perform immediate action to put the fire out while in harm's way before being able to move to a safe location. According to doctrine, the Strykers were to take casualties to ambulance exchange points, but the unit found that this extra step wasted time and risked lives. Squads in the unit typically made it an SOP to take injured peers to the nearest combat support hospital when it would not jeopardize the mission. This was because of the vehicle's survivability and mobility; even after being attacked, the Stryker vehicles could usually get soldiers to medical facilities quicker and safer than a military ambulance. Also worth noting was the exemplary job that the unit's medics performed, which saved the lives of many who would have died before reaching medical aid stations or combat support hospitals.

Soldiers were trained to recognize things that seemed out of the ordinary, and would identify possible threats and speed up all vehicles in a convoy. That was because the soldiers found that the second vehicle was often the one targeted, with the hopes it would be immobilized and pin down trailing vehicles for an attack. It became SOP to move through an attack to avoid presenting targets and allow the element to consolidate its forces for a counter attack. The situations encountered during the unit's first OIF rotation led it to practice scenarios that would develop SOPs for future scenarios it had not envisioned.

Sniper Operations

The 1/25 SBCT snipers were used extensively and provided cover and surveillance throughout rotation in all types of missions. The unit was not able to get as many slots as desired for the sniper course at Fort Benning and hopes to have a mobile course taught at Fort Lewis, Washington, in the future. The unit had to beg for rifles for the snipers they did have and in many cases used the M-4 in lieu of the M-14. Snipers also replaced the scopes with money from their own pockets because of their dissatisfaction

with the standard-issue scopes. The brigade suggested adding more roles for the snipers to doctrine for RSTA missions. Snipers and their spotters supported unit cordon-and-search operations by providing surveillance for both sides of a street on a block. Similarly, their using to identify HVTs at traffic control points was valuable. The unit found that joint urban operations require many more snipers than are needed during major combat operations.

Conclusion

Networking systems, the 1/25 SBCT's emphasis on carrying out distributed operations to reduce response and planning times, the use of snipers in unconventional surveillance roles, information-sharing concepts for rapidly exchanging information among distributed teams and airborne support and surveillance assets, and innovative ways of collecting intelligence at the tactical level without compromising cooperative Iraqi civilians all helped the unit develop a variety of cutting edge TTPs for stability operations.

Detailed Results of the Quality of Information and Collaboration Surveys

As discussed in Chapter Three, RAND surveyed 101st ABD, 3/2 SBCT, and 1/25 SBCT leaders to assess the quality of information and collaboration they experienced in a variety of areas. In particular, leaders were asked to assess the completeness, trustworthiness, and timeliness of information available to them. Chapter Six averaged these three ratings to produce a single “Quality of Information” score. This appendix displays the results for these three metrics individually. As noted in Chapter Six, averages for the three scores were almost always within one point (out of a five-point scale) of each other, and usually within a half-point of each other.

Figure C.1 displays the average completeness, trustworthiness, and timeliness scores for quality of information during cordon-and-search/knock-and-raid operations.

Figure C.2 displays the same quality of information scores for convoy operations.

Finally, Figure C.3 displays completeness, trustworthiness, and timeliness scores for the quality of collaboration and shared situation awareness.

Figure C.1
Detailed Quality of Information Results for Cordon-and-Search/Knock-and-Raid Operations

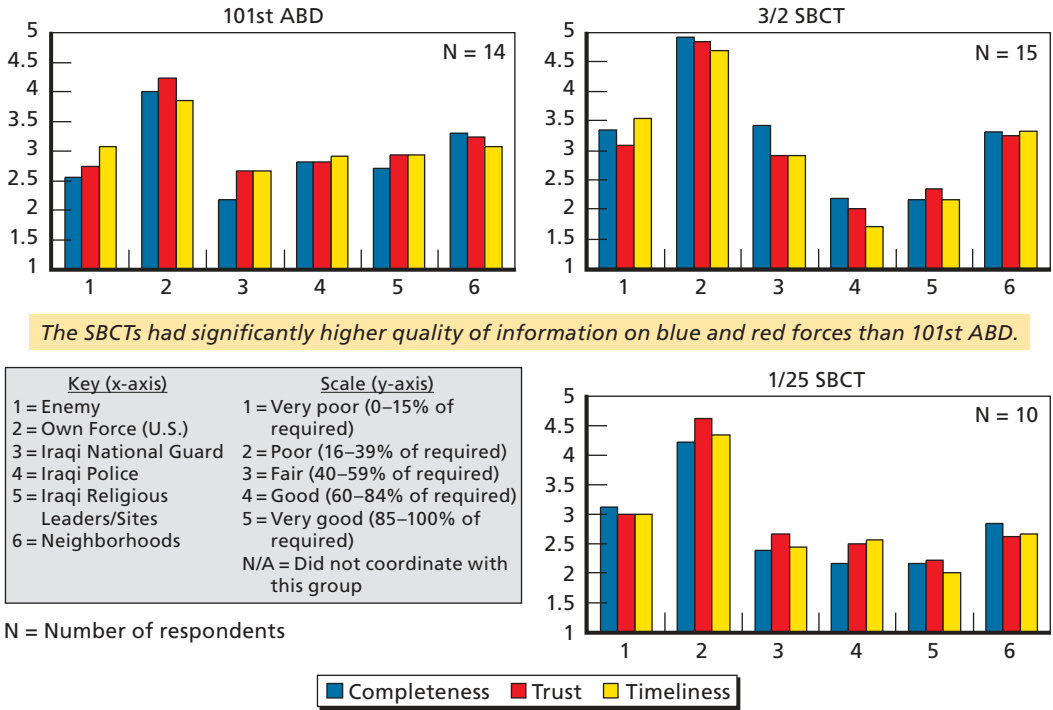

The SBCTs had significantly higher quality of information on blue and red forces than 101st ABD.

Figure C.2
Detailed Quality of Information Results for Convoy Operations

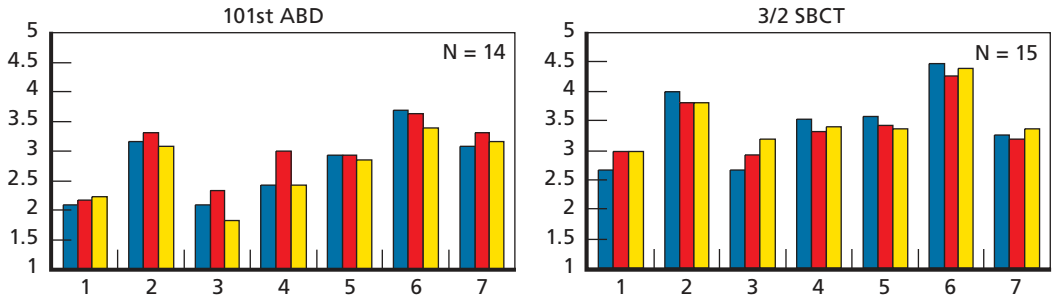

The SBCTs had significantly higher quality of information on blue and red forces, IED types, positions, and TTPs than 101st ABD.

Key (x-axis)	Scale (y-axis)
1 = Enemy Positions	1 = Very poor (0–15% of required)
2 = Enemy TTPs	2 = Poor (16–39% of required)
3 = IED Positions	3 = Fair (40–59% of required)
4 = IED Types	4 = Good (60–84% of required)
5 = Safe Routes	5 = Very good (85–100% of required)
6 = Own Force (U.S.)	N/A = Did not coordinate with this group
7 = Neighborhoods	

N = Number of respondents

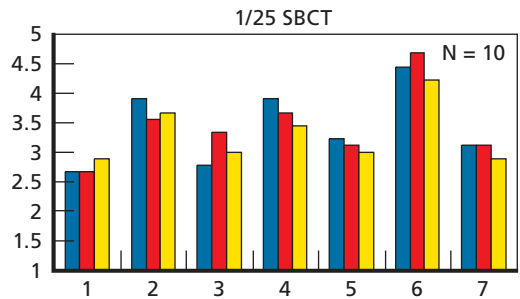

■ Completeness ■ Trust ■ Timeliness

Figure C.3
Detailed Quality of Collaboration and Shared Situation Awareness Results

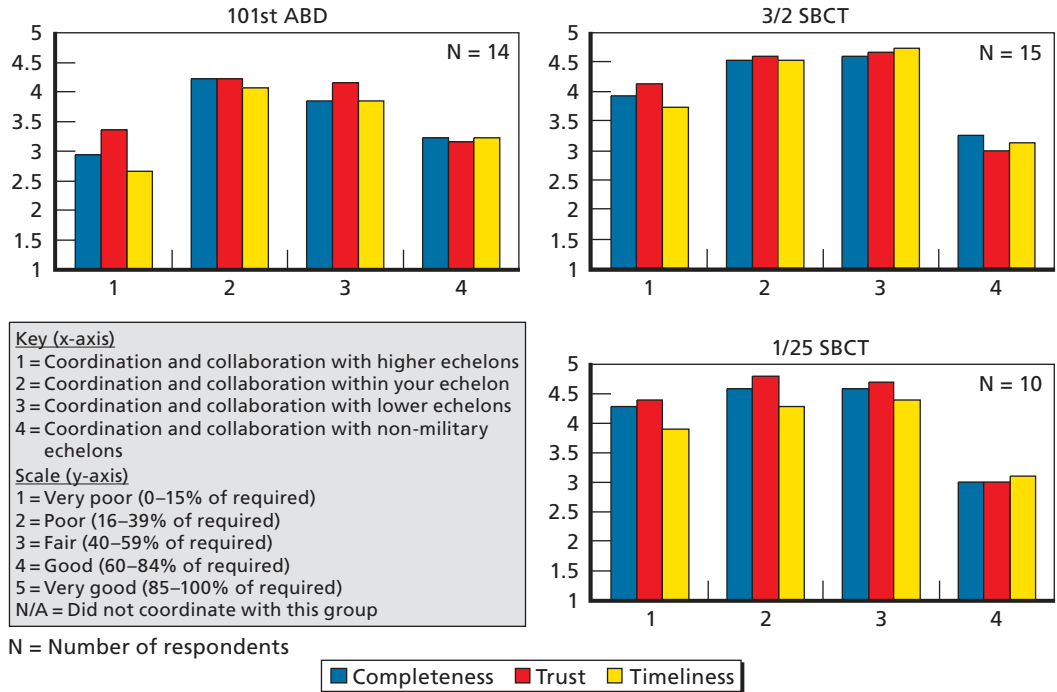

Iraqi National Elections

Political Progress

The first national elections in Iraq were held in January 2005 to elect an interim Iraqi parliament and form an interim national government. During this election, considerable violence in the country on election day deterred voters from voting, and a sizable percentage of Iraqi Sunnis boycotted the election (Sunni political parties boycotted the elections in many parts of Iraq).¹ Voter turnout for this election was estimated to be high, with an average turnout of 58 percent nationally, but it was much lower in Ninawah province, the 1/25 SBCT's AOR, where it was estimated to be only 17 percent.² Nevertheless, successful completion of this election was labeled as one of the major strategic victories for coalition forces in Iraq by LTG Thomas Metz, who was then MNF-I commander.³

A second election was held in October 2005 to ratify Iraq's new constitution. It was essential for the constitution to be ratified prior to national elections for a permanent Iraqi government. Before the election, a number of insurgent groups threatened voters and warned Iraqis not to participate in this election. In particular, insurgent groups including Al Qaeda in Iraq and Abu Musab al-Zarqawi said that they would

¹ Wikipedia, "Politics of Iraq," March 2006.

² Anthony H. Cordesman, "The Iraq War and Lessons for Counterinsurgency," Washington, D.C.: Center for Strategic and International Studies, March 16, 2006.

³ Metz, 2005.

kill Iraqis who voted in the referendum. Still other insurgent groups urged Iraqis to vote against the constitution.⁴

Figure D.1 illustrates the elements and organizations that comprised the Iraqi election system for the constitutional referendum. There were over 6,000 polling sites and over 500 voter registration sites. Ballot collection centers were located throughout the country and were funneled into three primary ballot collection centers in Mosul (the 1/25 SBCT’s AOR), Basra, and at Baghdad International Airport. These ballots were then flown to Dubai for final tabulations.

Figure D.1
Iraqi National Election System for the Constitutional Referendum

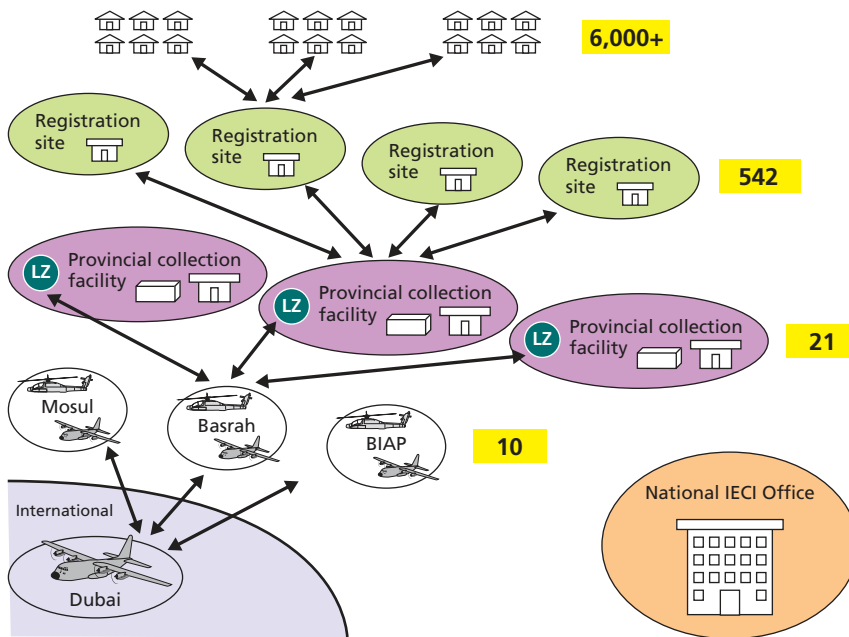

RAND MG593-D.1

⁴ Kirk Semple and Robert F. Worth, “Early Signs Show Iraqis’ Approval of Constitution,” *New York Times*, October 17, 2005, p. 1.

On election day, few attacks took place. Only nine attacks were reported in Baghdad, a small fraction of the average daily number of attacks in the capital. And reports from northern Iraq indicated that there was very little violence there as well. Only one Iraqi civilian was killed in the capital while casting his vote, and a handful of Iraqi soldiers were killed elsewhere.⁵ No Iraqi civilians were reported to be killed on election day in Ninawah province.

U.S. military officials attributed the peaceful vote to the security measures they took to secure polling places throughout the country. The number of ING battalions on duty in the capital grew to 18 from just one last January.⁶ The 1/25 SBCT provided security for the vote in northern Iraq with assistance from twelve ING battalions. U.S. security measures, with substantial assistance from ING forces, helped to deter insurgent attacks.

The Iraqi constitution was ratified by the electorate with high voter turnout by Iraqis in all provinces (see Figure D.2). Voter turnout in Ninawah province was still lower than elsewhere in Iraq but, at 58 percent, was much higher than in the earlier election held nine months earlier.⁷ In addition, large numbers of Sunnis reportedly voted in Ninawah province in the October election.⁸ Voter turnout was exceptionally high throughout Iraq—63 percent on average.⁹ Ninawah province was the swing state in the constitutional referendum election.

Iraq's next national election took place in December 2005. This election selected the first permanent members of the Iraqi parliament for formation of a permanent Iraqi national government. This election also occurred under relatively peaceful circumstances. Voter turnout throughout the country was higher still than turnout for the prior two elections. Sunni Arabs participated in the election by voting for a number of political parties and for candidates they submitted for office. For the election in December, voter turnout throughout Iraq was estimated to be close to 77 percent (exceptionally high by Western standards) and 70 percent in Ninawah province.¹⁰

⁵ Semple and Worth, 2005.

⁶ Semple and Worth, 2005.

⁷ Independent Electoral Commission of Iraq, "Certification of the Constitutional Referendum Final Results," press release, October 20, 2005.

⁸ COL Robert B. Brown, video teleconference, September, 14, 2006.

⁹ Independent Electoral Commission of Iraq, *Certification of the Constitutional Referendum Final Results*, October 25, 2005.

¹⁰ Cordesman, 2006.

Figure D.2
Results of the Iraqi Constitutional Referendum

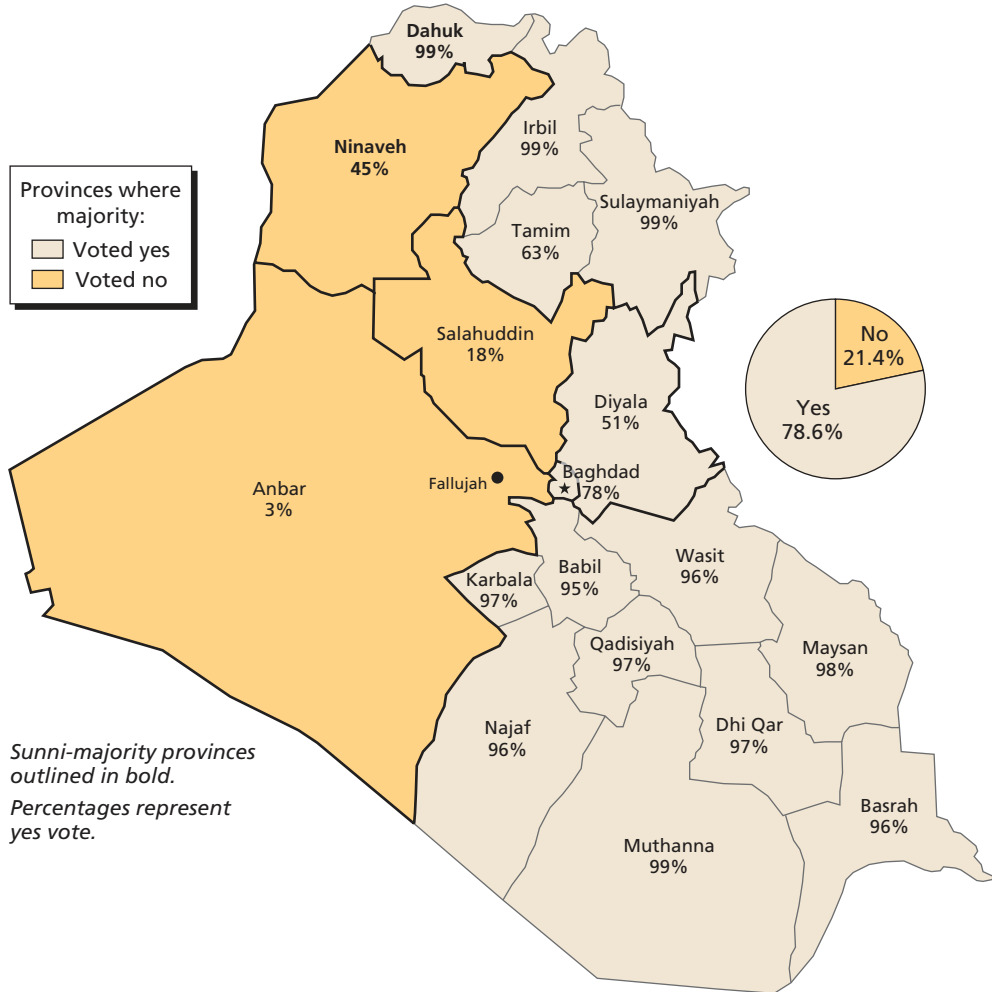

SOURCE: "Iraq voters back new constitution," BBC News, October 25, 2005, available online at <http://news.bbc.co.uk>.

RAND MG593-D.2

In summary, three successive elections have been held in Iraq with increasing voter turnout and decreasing levels of insurgent and terrorist attacks, despite threats from these groups. Two of the three Iraqi elections occurred while the 1/25 SBCT was stationed in northern Iraq, and the performance of this unit was important to the successful conduct of these elections in northern Iraq. At the same time, it should be noted that the reduction in the violence in successive elections can be viewed as a success for all of MNF-I; the 1/25 SBCT's performance was not unique in this respect.

Bibliography

Alberts, David S., *Mission Capability Packages*, Strategic Forum, Institute for National Strategic Studies, No. 14, January 1995.

Alberts, David S., and John J. Garstka, *Network Centric Warfare*, Department of Defense Report to Congress, July 27, 2001.

Alberts, David S., John J. Garstka, Richard E. Hayes, and David A. Signori, *Understanding Information Age Warfare*, Washington D.C.: CCRP Publication Series, August 2001.

Alberts, David S., John J. Garstka, and Frederick P. Stein, *Network Centric Warfare: Developing and Leveraging Information Superiority*, Second Edition (Revised), Washington, D.C.: CCRP Publication Series, 1999.

Alberts, David S., and Richard E. Hayes, *Power to the Edge: Command and Control in the Information Age*, Washington, D.C.: CCRP Publications Series, 2003.

"Al-Douri Chosen as the Leader of the Iraqi Ba'ath Party," *RPS News*, September 6, 2004.

Alexander, Caroline, "Iraqi Constitution Approved by 79 Percent of Voters," *Bloomberg*, October 25, 2005.

"Al Qaeda Finally Acknowledges Big Shot's Death," *New York Post*, October 21, 2005.

Axe, David, "The Road to Mosul: U.S. Troops Patrol the Insurgency's Front Door," *Village Voice*, May 3, 2005. As of June 21, 2007:
<http://www.villagevoice.com/news/0518,axe,63619,6.html>

"Baghdad Daily Reports on Dismissal of Mosul Governor," *RFE/RL Newslines*, April 1, 2004. As of June 15, 2007:
<http://www.hri.org/news/balkans/rferl/2004/04-04-01.rferl.html>

Binnendijk, Hans, and Stuart E. Johnson, eds., *Transforming for Stabilization and Reconstruction Operations*, Washington, D.C.: National Defense University Press, 2004.

Binnie, Jeremy, "JTIC Briefing: Zarqawi Aides Captured," *Jane's Terrorism and Insurgency Centre*, January 11, 2005.

Borne, Ron, "Army Transformation," U.S. Army Garrison, Hawaii, briefing, April 12, 2005.

Bowden, Mark, *Black Hawk Down: A Story of Modern War*, Berkeley, Calif.: Atlantic Monthly Press, 1999.

Brown, COL Robert, Commander, 1st Brigade, 25th Infantry Division, Multinational Force-Northwest, Special Defense Department Operational Update Briefing on Operations in Northwest Iraq, Multinational Force-Iraq, Baghdad, Iraq, September 14, 2005.

Cebrowski, Vice Admiral Arthur K., and John J. Garstka, "Network Centric Warfare: Its Origin and Future," *U.S. Naval Institute Proceedings*, January 1998.

CENTCOM Significant Activities (SIGACTs) Database. not releasable to the general public (portions only).

Center for Army Lessons Learned, *Exercise Arrowhead Lightning 2 Operational Evaluation (OE) Stryker Brigade Combat Team 1*, Initial Impressions Report No. 04-6, May 2003a, not releasable to the general public.

———, "Operation OUTREACH: Tactics, Techniques, and Procedures," U.S. Army Training and Doctrine Command, Fort Leavenworth, Kan., Newsletter No. 03-27, October 2003b, not releasable to the general public.

———, *Operation Iraqi Freedom Initial Impressions Report: Stability Operations, Support Operations*, U.S. Army Training and Doctrine Command, Fort Leavenworth, Kan., December 2003c, not releasable to the general public.

———, *JRTC Rotation 04-05 Lancer Storm Stryker Brigade Combat Team 2*, Initial Impressions Report No. 04-22, October 2004a, not releasable to the general public.

———, *Operations in Samarra, Iraq, Stryker Brigade Combat Team 1, 3rd Brigade, 2nd Infantry*, Initial Impressions Report No. 05-7, December 2004b, not releasable to the general public.

———, *OPERATIONS IN MOSUL, IRAQ IIR, Updated Final Draft*, 1st Brigade, 25th ID SBCT, March 15, 2005, not releasable to the general public.

Cockburn, Patrick, "Diary from Mosul," *London Review of Books*, Vol. 27, No 10, May 19, 2005.

Cockerham, Sean, "Leaving Iraq," *TheNewTribune.com*, October 30, 2006. As of June 15, 2007: <http://blogs.thenewtribune.com/iraq/>

Conatser, CAPT James, and CAPT Thane St. Clair, "Blue Force Tracking—Combat Proven," *Armor*, September–October 2003.

Cordesman, Anthony H., "The Iraq War and Lessons for Counterinsurgency," Washington, D.C.: Center for Strategic and International Studies, March 16, 2006.

Cox, Matthew, "They Weren't Going to Get This Bird," *Army Times*, November 22, 2004.

Daragahi, Borzou, Paul Richter, and Doug Smith, "Economy in Iraq Goes in All Directions," *Los Angeles Times*, January 2, 2006.

Department of Defense Directive (DoDD) 3000.5, *Military Support for Stability, Security, Transition, and Reconstruction (SSTR) Operations*, Washington, D.C., November 28, 2005. As of June 19, 2007: http://www.fas.org/irp/doddir/dod/d3000_05.pdf

Department of Defense, Office of Force Transformation, *Network Centric Operations Conceptual Framework*, Version 2.0, August 20, 2004.

Dolan, Ronald E., *Somalia/Operation GOTHIC SERPENT, A History of the 160th Special Operations Aviation Regiment (Airborne)*, Prepared for the Library of Congress Under an Interagency Agreement with the 160th Special Operations Aviation Regiment (Airborne), October 2001.

Encyclopedia Britannica Online, "Mosul," 2007. As of June 21, 2007:
<http://www.britannica.com/eb/article-9053936/Mosul>

Filkins, Dexter, "Iraq's Sunnis Voted in Larger Numbers This Time, Officials Say," *New York Times*, October 21, 2005.

Fisher, Paul, and Fred Stein, "Digitally Deployed (Signal Transformation in Combat): 3/2 Stryker Brigade Combat Team Operation Iraqi Freedom," *Army Communicator*, Summer 2004.

Friedenauer, Margaret, "Stryker Brigade Finds Huge Weapons Caches," *Fairbanks Daily News*, October 20, 2005.

Gonzales, Daniel, Michael Johnson, Jimmie McEver, Dennis Leedom, Gina Kingston, Michael S. Tseng, *Network-Centric Operations Case Study: The Stryker Brigade Combat Team*, Santa Monica, Calif.: RAND, MG-267-1-OSD, 2005a. As of August 14, 2007:
<http://www.rand.org/pubs/monographs/MG267-1/>

Gonzales, Daniel, John Hollywood, Gina Kingston, and David Signori, *Network-Centric Operations Case Study: Air-to-Air Combat With and Without Link 16*, Santa Monica, Calif.: RAND, MG-268-OSD, 2005b. As of August 14, 2007:
<http://www.rand.org/pubs/monographs/MG268/>

Gordon, Michael R., "101st Airborne Scores Success in Reconstruction of Northern Iraq," *New York Times*, September 4, 2003.

Gordon, Michael R., and Bernard E. Trainor, *Cobra II: The Inside Story of the Invasion and Occupation of Iraq*, New York: Pantheon, March 2006.

Gouré, Daniel, and Kenneth A. Steadman, "Medium Armor and the Transformation of the U.S. Military," The U.S. Army Professional Writing Collection, Lexington Institute, September 2004.

"Governor of Mosul Killed in Iraq," *RTE News*, July 14, 2004. As of June 21, 2007:
<http://rte.ie/news/004/0714/iraq02.html>

Graham, Bradley, "Enemy Body Counts Revived: U.S. Is Citing Tolls to Show Success in Iraq," *Washington Post*, October 24, 2005.

Grant, Greg, "Experts Assess U.S. Military Efforts in Iraq," *Defense News*, November 7, 2005.

Hutchins, Bill, "Helicopter Heroes," *News Tribune*, February 12, 2005.

Independent Electoral Commission of Iraq, "Certification of the Constitutional Referendum Final Results," press release, October 20, 2005.

———, *Certification of the Constitutional Referendum Final Results*, October 25, 2005.

International Monetary Fund, "Iraq: Statistical Appendix," IMF Country Report No. 05/295, Washington, D.C., August 2005.

"Iraq Voters Back New Constitution," *BBC News*, October 25, 2005. As of June 21, 2007: http://news.bbc.co.uk/1/hi/world/middle_east/4374822.stm

"Iraqi Governor Killed in Attack," *BBC News*, July 14, 2004. As of June 29, 2007: http://news.bbc.co.uk/2/hi/middle_east/3894653.stm

"Iraqi Soldiers Found Murdered in Mosul," *Sydney Morning Herald*, November 22, 2004. As of June 21, 2007: <http://www.smh.com.au/news/After-Saddam/Iraqi-soldiers-found-murdered-in-Mosul/2004/11/21/1100972263000.html>

"Is Syria Harboring Saddam?" *Middle East Intelligence Bulletin*, Vol. 5, No. 6, June 2003. As of June 21, 2007: http://www.meib.org/articles/0306_s1.htm

Kagan, Frederick W., "A Plan for Victory in Iraq: Defeat the Insurgents Militarily—Here's How," *Weekly Standard*, May 29, 2006.

Kane, MAJ Thomas, "One Year Later, Success in Mosul," *Scimitar*, Vol. 4, No. 5, February 3, 2006.

Kaplan, Robert D., "The Coming Normalcy?" *Atlantic Monthly*, Vol. 297, No. 4, April 2006, pp. 72–81.

Katz, Rita, SITE institute director, presentation to the JIEDDO Intelligence Summit, Pensacola Fla., May 2006.

Knights, Michael, "Lessons from Mosul," *PolicyWatch*, No. 950: Washington, D.C.: Washington Institute for Near East Policy, January 27, 2005.

Larson, Specialist Blair, "Medical Heroics Save Lives in Mosul Attack," *Olympia Observer*, Vol. 1, No. 40, December 27, 2004.

———, "Terrorists Flee Tal Afar in Face of Coalition," *Army News Service*, September 24, 2004. As of June 21, 2007: http://www4.army.mil/ocpa/read.php?story_id_key=6395

Lasseter, Tom, "Divided Army Has Intensified Strife in Iraq," *Philadelphia Inquirer*, January 2, 2006.

"Lessons of the Iraq War and Its Aftermath," *PolicyWatch*, No. 855: *Special Forum Report Featuring David Petraeus*, Washington, D.C.: Washington Institute for Near East Policy, April 9, 2004. As of June 19, 2007: <http://www.washingtoninstitute.org/templateC05.php?CID=1733>

"Letter Shows Concern over TV Killings," *Agence France Presse*, October 8, 2005.

Maffei, Glenn, "Stryker BCT Excels with Network-Centric Concepts," *Inside the Army*, September 5, 2005.

Marks, Alexandra, "Terror's Media: War over the Web," *Christian Science Monitor*, October 13, 2005.

Measuring Stability and Security in Iraq, Report to Congress, House Conference Report 109-72, Washington, D.C., 2005.

McCarthy, Rory, "Gunmen Kill Mosul Governor," *Guardian*, July 15, 2004, As of June 21, 2007: <http://www.guardian.co.uk/Iraq/Story/0,2763,1261692,00.html>

Memorial Institute for the Prevention of Terrorism, Terrorism Knowledge Base, Washington, D.C. As of June 6, 2007: <http://www.tkb.org>

Metz, LTG Thomas, "Operation Iraqi Freedom II," briefing, August 1, 2005, not releasable to the general public.

Misterek, Matt, "Strykers Destroy Suspected Car Bombs in Sweep," *News Tribune*, June 1, 2005.

"Mosul Deputy Police Chief Assassinated," *Guardian Unlimited*, February 25, 2004. As of June 21, 2007: <http://www.guardian.co.uk/Iraq/Story/0,,1155940,00.html>

"Mosul Police Chief Shot," *BBC World Service*, August 16, 2003. As of June 21, 2007: http://news.bbc.co.uk/2/hi/middle_east/3156867.stm

Multi-National Force–Iraq, "Ninawa," 2006, As of June 21, 2007: http://www.mnf-iraq.com/index.php?option=com_content&task=view&id=1483

National Strategy for Victory in Iraq, Washington, D.C.: The White House, November 2005.

"Network Centric Operations Conceptual Framework Version 1.0," Vienna, Va.: Evidence Based Research, Inc., 2003.

North, CPT Brian, "Communications Lessons Learned, 2D Brigade, 101st Airborne Division (AASLT)," Center for Army Lessons Learned, U.S. Army Training and Doctrine Command, Fort Leavenworth, Kan., March 28, 2005, not releasable to the general public.

O'Hanlon, Michael, and Nina Kamp, *Iraq Index: Tracking Variables of Reconstruction and Security in Post-Saddam Iraq*, Washington, D.C.: The Brookings Institution, June 8, 2006. As of June 21, 2007: <http://www.brookings.edu/saban/iraq-index.aspx>

Packer, George, "Letter from Iraq; The Lesson of Tal Afar," *New Yorker*, April 10, 2006.

Perry, Walter L., David Signori, and John E. Boon, Jr., *Exploring Information Superiority: A Methodology for Measuring the Quality of Information and Its Impact on Shared Awareness*, Santa Monica, Calif.: RAND Corporation, MR-1467-OSD, 2004. As of August 14, 2007: http://www.rand.org/pubs/monograph_reports/MR1467/

Petraeus, LT GEN David H., "Learning Counterinsurgency: Observations from Soldiering in Iraq," *Military Review*, January–February 2006.

Public Broadcasting Service, "Inside the Iraqi Insurgency," *Documentary, Frontline News Magazine*, February 21, 2006.

Quinlivan, James T., "Force Requirements in Stability Operations," *Parameters*, Winter 1995, pp. 59–69.

Riccardi, Nicholas, and Edmund Sanders, "Insurgents Rule the Roads," *Los Angeles Times*, April 19, 2004. As of June 21, 2007:

http://www.strykernews.com/archives/2004/04/19/insurgents_rule_the_roads.html

Robinson, Glenn E., and Kalev Sepp, "Current Insurgency in Iraq in the Context of Historical Islam," briefing at the Conference on Understanding Terrorist Networks and Organizations, Naval Postgraduate School, Monterey, April 7, 2005.

Rounds, COL Michael, USA, "Arrowhead Brigade Combat Team in OIF I and II," PowerPoint presentation, November 16, 2004, not available to the general public.

Rzeplinski, Michael, "Information Dissemination Management–Tactical (IDM-T)," undated briefing, IDM-T Program Office, Fort Monmouth, N.J.

Schoomaker, GEN Peter, and GEN Richard Cody, Media Roundtable at the Association of the United States Army Annual Convention, Washington, D.C., October 26, 2004.

Semple, Kirk, and Robert F. Worth, "Early Signs Show Iraqis' Approval of Constitution," *New York Times*, October 17, 2005, p. 1.

Signori, David A., "A Conceptual Framework for Network Centric Warfare," presented at the Technical Cooperation Program's Network Centric Warfare/Network Enabled Capabilities Workshop, Virginia, December 17, 2002. As of June 21, 2007:

<http://www.splc.net/isis/presentations/network-centric.pdf>

Sisemore, MAJ James D., *Does the 'SBCT' Intelligence Structure Need a Dedicated ACE / Fusion Cell?* Fort Leavenworth, Kan.: United States Army School of Advanced Military Studies, United States Army Command and General Staff College, Academic Year 2003–2004.

Steinberg, Guido, *The Iraqi Insurgency: Actors, Strategies, and Structures*, Berlin: Stiftung Wissenschaft und Politik, German Institute for International and Security Affairs, 2006. As of June 19, 2007:

http://www.swp-berlin.org/en/common/get_document.php?asset_id=3560

"Targeting for Victory: Winning the Civil Military Operations," Center for Army Lessons Learned, U.S. Army Training and Doctrine Command, Fort Leavenworth, Kan., Newsletter No. 03-23, September 2003, not releasable to the general public.

Townsell, Tonya K., "Enhancements in Store for Future Stryker Brigades," *Army Communicator*, Winter 2003. As of June 21, 2007:

http://www.findarticles.com/p/articles/mi_m0PAA/is_4_28/ai_n6118596

Townsend, COL Stephen J., "Observations on the Battle of Tall Afar, Iraq, 4 September, 2004, Operation Assyrian Drifter, Day 2," September 24, 2004.

U.S. Army, *Army Battle Command Executive Overview*, Version 6.x, January 2003, not releasable to the general public.

U.S. Army Infantry School, 3/2 Stryker Brigade Lessons Learned Conference, Fort Lewis, Wash., March 23–24, 2005 (briefings and interviews), not releasable to the general public.

U.S. Army Infantry School, 1/25 Stryker Brigade Lessons Learned Conference, Fort Lewis, Wash., February 7–8, 2006 (briefings and interviews), not releasable to the general public.

The U.S. Army in 2004 and Beyond: Strategically Agile and Adaptive, Arlington, Va.: Institute of Land Warfare, Association of the United States Army, February 2004. As of June 21, 2007:
http://www.ausa.org/pdfdocs/LWPapers/TB_StratBook.pdf

U.S. Army, *Operation Iraqi Freedom Lessons Learned*, 101st Airborne Division (Air Assault), May 23, 2003, not releasable to the general public.

U.S. Army Training and Doctrine Command (TRADOC), *Interim [Stryker] Brigade Organizational and Operational Concept*, Ft. Leavenworth, Kan., June 30, 2000,

U.S. Department of Commerce, “Plan to Select Spectrum for Third Generation Wireless Systems in the United States—Attachment 3, Spectrum Use Summary of the United States,” January 22, 2001. As of June 21, 2007:
<http://www.ntia.doc.gov/ntiahome/threeg/3gattach3.htm>

U.S. Department of State, “‘Quiet, Steady Progress’ Occurring in Iraq, Bush Says, President Details Reconstruction Efforts; Reaffirms U.S. Commitment,” December 7, 2005. As of June 21, 2007:
<http://usinfo.state.gov/xarchives/display.html?p=washfile-english&y=2005&m=December&x=20051207133947frllehctim0.133877>

“US ‘Intercepts al-Qaeda Letter,’” *BBC News*, October 7, 2005. As of June 21, 2007:
http://news.bbc.co.uk/2/hi/middle_east/4318478.stm

U.S. Special Operations Command (USSOCOM), “Task Force Ranger Operations in Somalia,” History and Research Office, MacDill Air Force Base, Fla., June 2001, not available to the general public.

Ward, Celeste J., *The Coalition Provisional Authority’s Experience with Governance in Iraq: Lessons Identified*, Special Report 129, Washington, D.C.: United States Institute of Peace, May 2005.

Warner, Senator John, and Senator Carl Levin, “Review of the Circumstances Surrounding the Ranger Raid on October 3–4, 1993 in Mogadishu, Somalia,” Memorandum for Senator Thurmond and Senator Nunn, Washington, D.C.: United States Senate Committee on Armed Services, September 29, 1995.

Wikipedia, “Politics of Iraq,” March 2006. As of June 21, 2007:
http://en.wikipedia.org/wiki/Politics_of_Iraq

Wilson, G. I., Greg Wilcox, and Chet Richards, "Fourth Generation Warfare and OODA Loop Implications of the Iraqi Insurgency," briefing, December 2004.

Yon, Michael, "The Punishers' Ball," *Michael Yon: Online Magazine*, November 17, 2005. As of June 21, 2007:

<http://www.michaelyon-online.com/wp/the-punishers-ball.htm>

"Zawahiri Letter Reveals Concerns over Impact of Televised Executions," *Agence France Presse*, October 7, 2005.