

## New Model of Linear Induction Drive

R. Rinkevičienė, A. Petrovas

Automation Dept., Vilnius Gediminas Technical University

Naugarduko str. 41, LT-03227, Vilnius; e-mail: [roma.rinkeviciene@el.vtu.lt](mailto:roma.rinkeviciene@el.vtu.lt)

### Introduction

Application of linear induction motors (LIM) for translation gives the possibility to diminish weight of drive moving parts and entire drives of electromechanic system, enlarges operating speeds and accelerations. In many cases a new construction of equipment is developed where the linear motor becomes an incorporated part of that [1,2].

LIM can successfully be applied in the equipment where there are possibilities to coincide the secondary with conductive parts of controlled equipment or in the equipment where extra high speed is required or flexibility of technology is requested. LIM secondary can be made from material characterized with small specific weight. Therefore every LIM must be designed according to specific construction features, speeds and loads. LIM can be optimised for particular equipment and its design can be automated. Nevertheless by way of investigation broadening and shrinking areas of application can be defined.

The larger air gap of LIM determines the greater losses. Thus the main area where it is more expedient is equipment to apply LIM in the equipment with short time and intermediate operating mode [4-6]. During those operating modes a speed of secondary usually does not reach steady state values and currents of inductor winding also does reach that. A drive operates in dynamic mode. Electromagnetic transients in the linear motor must be taken into account in order to investigate characteristics of such drives. As well as open magnetic circuit of LIM causes asymmetry of currents the paper presents new generalized model of linear induction motor with consideration of electric and magnetic asymmetry due to open magnetic circuit of LIM. Model does not employ transform of coordinates.

### Dynamic models of linear induction motors

It is assumed in electric drive theory that any electric machine with n-phase stator winding and m-phase rotor winding at equal stator and rotor impedances can be replaced by equivalent two-phase machine which is called generalized electric machine [7, 8]. Generalized electric machine is simplified model of real electric machine. It does not take into account asymmetry of magneto motive forces and non-even distribution of magnetic flux in the air gap.

To analyze dynamic processes it is assumed that magnetic circuit is not saturated and magnetic permeability is high. Besides it is assumed that multiphase machine is symmetrical therefore impedances of equivalent two-phase machine are equal [7, 8].

According to traditions rotary or linear motors are modelled by transformation three-phase motor to equivalent two-phase one and deriving equations in the stationary reference frame or revolving (translating) reference frame. Indices  $\alpha$ ,  $\beta$  denote stationary reference frame and  $u$ ,  $v$  - reference frame rotating with speed  $\omega_k$  (or translating with speed  $v_k$ ). When  $\omega_k$  ( $v_k$ ) is equal to velocity of magnetic field  $\omega_{0el}$  ( $v_{0el}$ ), such reference frame is called  $x$ ,  $y$ .

Papers [9-12] consider dynamics of low speed drives with linear induction motors which secondary do not leave inductor boundaries. Longitudinal end effect of that motors is weak and cannot be taken into consideration. Equations of three-phase energy converter written in reference frame  $x$ ,  $y$  moving with synchronous speed  $v_0$  are taken as base of investigations. Source [13] describes and compares results of linear drives investigation and modelling in the reference frame  $x$ ,  $y$  and  $\alpha$ ,  $\beta$ . Results do not depend on reference frame. Model in  $\alpha$ ,  $\beta$  reference frame is simpler.

### Model of three phase linear induction motor

Investigation of controlled linear electric drives supplied by frequency converter meets difficulties to transform the source voltage into any other translating reference frame. Designed and elaborated new model of three phase linear induction model in the stationary reference frame gives possibility to model three phase converter and linear induction motor without transformation of coordinates.

Model of linear induction motor deals with three objects: winding object, mechanical part object and electromechanical part object.

Winding object models single winding of a motor. Three phase motor with single pole pair consists of six winding objects: three in an inductor and three in a rotor (secondary).

Object of mechanical part models mechanical part of induction motor, i.e. mechanical motion. Linear and rotating induction motors differ just by their mechanical part.

Electromechanical part joins into one-model objects of winding and mechanical part. This object transforms electrical quantities to mechanical quantities of mechanical part. It is possible to state that object of electromechanical part is sample of abstract model. If two first models exist in a material form the last one – just in mathematical.

Electrical properties of three-phase induction motor are described by equations of voltage equilibrium:

$$\left\{ \begin{array}{l} u_A = \frac{d\Psi_A}{dt} + R_A i_A \\ u_B = \frac{d\Psi_B}{dt} + R_B i_B \\ u_C = \frac{d\Psi_C}{dt} + R_C i_C \\ u_a = \frac{d\Psi_a}{dt} + R_a i_a \\ u_b = \frac{d\Psi_b}{dt} + R_b i_b \\ u_c = \frac{d\Psi_c}{dt} + R_c i_c \end{array} \right. \quad (1)$$

where  $u_A, u_B, u_C, u_a, u_b, u_c$  – instantaneous values of inductor and secondary element voltages;  
 $\Psi_A, \Psi_B, \Psi_C, \Psi_a, \Psi_b, \Psi_c$  – flux linkages of inductor and secondary element;  
 $R_A, R_B, R_C, R_a, R_b, R_c$  – phase resistances of inductor and secondary element;  
 $i_A, i_B, i_C, i_a, i_b, i_c$  – instantaneous values of inductor and secondary element currents.

Magnetic properties of windings are described by system of equations as:

$$\left\{ \begin{array}{l} \Psi_A = L_A i_A + M_S (i_B + i_C) + \\ + M_{SR} [i_a \cos \varphi + i_b \cos(\varphi + 120^\circ) + i_c \cos(\varphi - 120^\circ)] \\ \Psi_B = L_B i_B + M_S (i_A + i_C) + \\ + M_{SR} [i_a \cos(\varphi - 120^\circ) + i_b \cos \varphi + i_c \cos(\varphi + 120^\circ)] \\ \Psi_C = L_C i_C + M_S (i_A + i_B) + \\ + M_{SR} [i_a \cos(\varphi + 120^\circ) + i_b \cos(\varphi - 120^\circ) + i_c \cos \varphi] \\ \Psi_a = L_a i_a + M_R (i_b + i_c) + \\ + M_{SR} [i_A \cos \varphi + i_B \cos(\varphi - 120^\circ) + i_C \cos(\varphi + 120^\circ)] \\ \Psi_b = L_b i_b + M_R (i_a + i_c) + \\ + M_{SR} [i_A \cos(\varphi + 120^\circ) + i_B \cos \varphi + i_C \cos(\varphi - 120^\circ)] \\ \Psi_c = L_c i_c + M_R (i_a + i_b) + \\ + M_{SR} [i_A \cos(\varphi - 120^\circ) + i_B \cos(\varphi + 120^\circ) + i_C \cos \varphi] \end{array} \right. \quad (2)$$

where  $M_{SR}$  – mutual inductance between inductor and rotor (secondary element) when the axes of coils coincide [H];  $M_S, (M_R)$  – mutual inductance between different coils of inductor (rotor or secondary element) in H;  $M_R$  – mutual inductance between different coils rotor or secondary

element in H;  $\varphi$  – angle between rotor and inductor coils in electric degrees.

Substituting expression of phase A flux linkage from (2) into voltage equilibrium equation (1) for phase A, gives:

$$u_A = L_A \frac{di_A}{dt} + R_A i_A + \Delta, \quad (3)$$

where

$$\Delta = M_S \frac{d(i_B + i_C)}{dt} + M_{SR} \frac{d[i_a \cos \varphi + i_b \cos(\varphi + 120^\circ) + i_c \cos(\varphi - 120^\circ)]}{dt}, \quad (4)$$

$\Delta$  is nonlinear term evaluating influence of currents flowing in the other two phase windings.

Apply Laplace transform for equation (3) and obtain expression as:

$$I_A(s) = L[(u_A(t) - \Delta)] \cdot \frac{1}{L_A s + R_A}, \quad (5)$$

where  $L$  is notation of Laplace transform operation.

Block diagram of model of phase A winding object is presented in the Fig.1. The model has seven inputs, shown as ovals with arrows pointing out from that and one output shown as oval with arrow pointing to that.

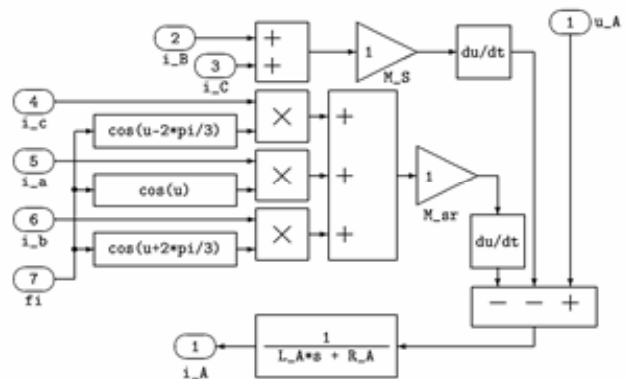

Fig. 1. Model of a winding object

Models of all other windings are constructed in the same way.

Mechanical motion of rotor (or secondary element of LIM) is described by generalized equation as:

$$A_{em} - A_l = b_{red} \frac{d^2 l}{dt^2}, \quad (6)$$

where  $A_{em}$  is electromagnetic quantity causing motion, i.e. electromagnetic torque in rotating motor and electromagnetic force in linear motor;  $A_l$  is quantity opposing to movement, i.e. load torque in rotating motor and load force in linear motor;  $b_{red}$  is quantity characterizing inertia of moving part; it is inertia of

rotating motor or mass of moving parts of linear motor;  $l$  - quantity corresponding to covered distance, i.e. rotation angle  $\varphi$  in the rotating motor and excursion of secondary in linear motor.

In order to make generalized model and apply it to rotating and linear induction motors, suppose that linear induction motor is simply cut and straightened rotating one i.e. all end effects of LIM are neglected what is applicable to small power and low speed linear motors. Thus low speed linear motor can be modelled by equivalent rotating motor. Dependences between mechanical quantities in both motors can be expressed as:

$$F_{em} = k_1 \cdot M_{el};$$

$$\varphi = k \cdot l;$$

where  $k = \frac{\pi}{\tau}$ ,  $k_1 = \frac{k}{p}$ ;  $\tau$  is pole pitch;  $n$  is number of pole pairs.

Model of a mechanical part object is presented in Fig.2.

An expression is derived to calculate electromagnetic torque of motor looks like this:

$$\begin{aligned} M_{em} = & -pM_{SR}[(i_A i_a + i_B i_b + i_C i_c) \sin \varphi] - \\ & -pM_{SR}[(i_A i_a + i_B i_b + i_C i_c) \sin(\varphi + 120^\circ)] - \\ & -pM_{SR}[(i_A i_a + i_B i_b + i_C i_c) \sin(\varphi - 120^\circ)] \end{aligned} \quad (7)$$

To model electromagnetic part by basic blocs of Simulink is not convenient. If the term in brackets is programmed with Matlab programming language model becomes a simpler. Block diagram of object of electromechanical part is presented in Fig.3. An expression

$$\begin{aligned} & (u(1) * u(4) + u(2) * u(5) + u(3) * \\ & * u(6) * \sin(u(7)) + \dots \\ & (u(1) * u(5) + u(2) * u(6) + u(3) * \\ & * u(4) * \sin(u(7) + 2 * \pi / 3)) + \dots \\ & (u(1) * u(6) + u(2) * u(4) + u(3) * \\ & * u(5) * \sin(u(7) - 2 * \pi / 3)) + \dots \end{aligned} \quad (8)$$

is programmed in the function block  $F(u)$ . According to that unchangeable and parenthetic parts of expression (7) are calculated. All other calculations as multiplication by number of pole pairs and mutual inductance between inductor and rotor are removed to separate blocks.

Model of linear induction motor is constructed using all considered parts of model. The model is located in subsystem with seven inputs and one output. Inputs are supplied as in real motor by instantaneous phase voltages and load force.

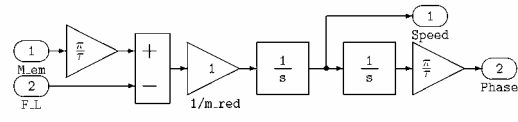

Fig. 2. Model of a mechanical part object

Designed model of linear induction motor is shown on Fig. 4. There output gives the main characteristic of motor – dependence of speed against time.

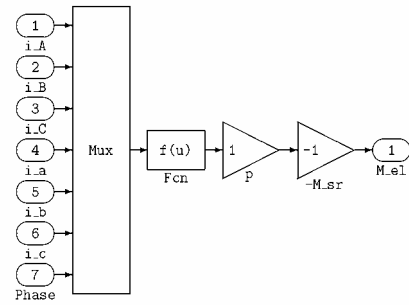

Fig.3. Model of electromechanical part object

Model gives possibility to get transients of inductor and secondary currents as well as electromagnetic force and speed of secondary. Fig. 5 shows transient currents in the secondary at LIM starting.

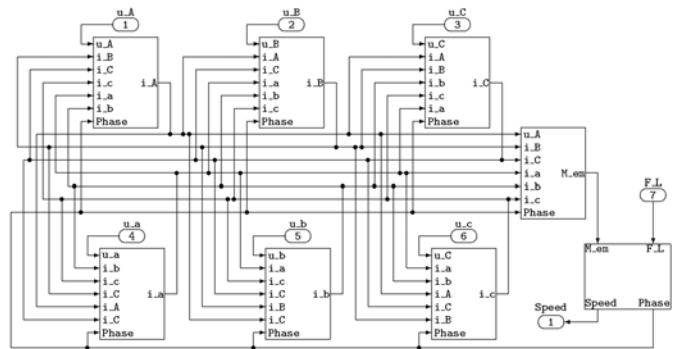

Fig. 4. Model of linear induction motor

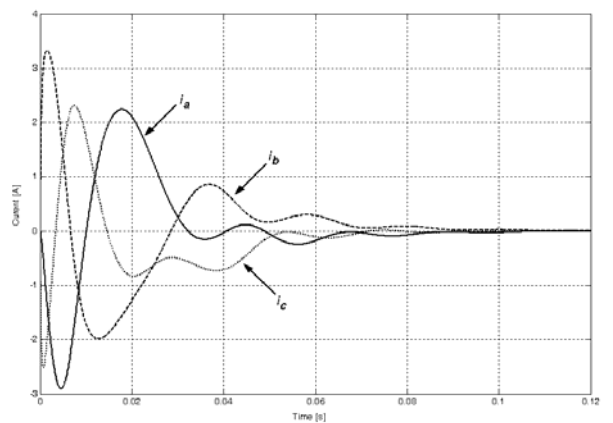

Fig. 5. Transient currents at the secondary at LIM starting

## Conclusions

1. Developed new model of LIM gives possibility to consider magnetic and electric non-symmetry due to open magnetic circuit of linear motor.
2. Designed new model of linear induction motor gives possibility to investigate transients at balanced and non-balanced supply voltages and phase angles between them.
3. Developed model without transformation of coordinates facilitates investigation control modes of electric drives with linear induction motor.

## References

1. **Boldea I.** Linear electric actuators and their control: a review // Proceedings of the 10th International Conference European Power and Drives Association PEMC 2002, 9-11 September 2002, Cavtat & Dubrovnik, Croatia. ISBN: 953-184-047-4. – P. 12-19.
2. **Budig P.-K.** The Application of Linear motors // The Third International Power Electronics and Motion Control Conference, 2000. – Vol. 3. – P. 1336-1341.
3. **Poška A., Rinkevičienė R.** Dynamics of electric drive of high voltage circuit-breaker for shunting phase fault. // The XIII International Conference on Electromagnetic Disturbances EMD'2003. 24-26 September, 2003. – Bialystok, Poland. – P.5.6-1-5.6-4.
4. **Poška A., Rinkevičienė R.** Automatic systems of shunting of faulted phase for elimination overvoltages // XI International Conference on Electromagnetic Disturbances 2001. – P.8.2-1-8.2-4.
5. **Poška A., Rinkevičienė R.** Protection from overvoltages in 10 kV networks// The XII International Conference on Electromagnetic Disturbances EMD'2002. 25-27 September, 2002. – Palanga, Lithuania. – P. 49-50.
6. **Rinkevičienė R., Poška A.** Cylindrical linear electric drives of industrial mechanisms. The 10th European conference on Power Electronics and Applications. Toulouse, France, 2-4 September, 2003. Issued on CD-ROM 7 p.
7. **Ключев В. И.** Теория электропривода: Учебник для вузов.– М.: Энергоатомиздат,1985.–560 с.
8. **Копылов И. П.** Электрические машины. М.: Высшая школа. 2000.– 607 с.
9. **Rinkevičienė R.** Elektros pavarų su tiesiniais cilindriniais varikliais dinaminės charakteristikos. Kauno technologijos universitetas. Elektrotechnika, 17(26) // Mokslo darbai. Kaunas: Technologija, 1992. – P.126-134.
10. **Соколов М. М., Ринкевичене Р. В.** Электромеханические процессы в линейном электроприводе толкателя // Электричество.- 1990. – № 3. – С. 75 - 78.
11. **Poška A., Rinkevičienė R., Teišerskas Č.** Tiesiaieigės asinchroninės pavaros skaitmeniniai dinaminiai modeliai // Elektronika ir elektrotechnika. ISSN 1392-1215. Kaunas: Technologija, 1997. – Nr. 1(10). – P. 50-54.
12. **Poška A., Rinkevičienė R., Teišerskas Č.** Tiesiaieigės elektros pavaros impulsinis valdymas // Elektrotechnika Mokslo darbai.- Kaunas: Technologija, 1997. – T. 21(30). – P. 137-140.
13. **Rinkevičienė R., Lisauskas S.** Tiesiaieigių mechatroninių sistemų modeliai // Elektronika ir elektrotechnika. Kaunas: Technologija, 2003. -Nr. 4(46)/- P. 69–73.

Pateikta spaudai 2004 02 17

### **R. Rinkevičienė, A. Petrovas. Tiesiaieigės asinchroninės pavaros modelis // Elektronika ir elektrotechnika. – Kaunas: Technologija, 2004. – Nr. 2(51). –P. 25-28.**

Straipsnyje nagrinėjamas tiesiaieigės asinchroninės pavaros matematinis modelis ir jo pagrindu sukurtas imitacinis modelis tiesiaieigių asinchroninių pavarų dinaminiam režimams tirti. Sudarytasis modelis leidžia tirti elektros pavarų su sukiaisiais ar tiesiaieigiais asinchroniniais varikliais pereinamuosius procesus, esant simetrinėms ar nesimetrinėms maitinimo įtampoms, esant vienodiems ar skirtingiems fazinių apvijų parametrų, paleidžiant apkrautą arba neapkrautą variklį. Išvesta formulė sukuriamai variklio jėgai ar momentui apskaičiuoti. Pavaros modelis sudarytas kaip visuma objektų modelių, atitinkančių atskiras modelio dalis: apvijų objekto modelio, mechaninės dalies objekto modelio ir elektromechaninės dalies objekto. Pateiktos šių objektų modelių schemas. Išnagrinėtos sukiojo ir tiesiaieigio asinchroninio variklio parametrų priklausomybės, reikalingos modeliui sudaryti. Skaičiavimo rezultatai: variklio sukuriama jėga, greitis, induktoriaus bei antrinio elemento kiekvienos fazinės apvijos srovės ir kiti parametrai gaunami grafikų forma. Il. 5, bibl. 13 (anglų kalba; santraukos lietuvių, anglų ir rusų k.)

### **R. Rinkevičienė, A. Petrovas. Model of Linear Induction Drive // Electronics and Electrical Engineering. – Kaunas: Technologija, 2004. – No. 2(51). - P. 25-28.**

The article deals with mathematical model of linear induction drive and a developed Simulink model based on that. Developed model gives possibility to investigate transients of electric drives with rotating and linear induction motors at balanced and unbalanced supply voltage and at equal or distinct parameters of phase windings during starting process of motor with load or no-load. Derived formula to calculate developed force or torque is presented. Model of linear induction motor is developed as entity of objects corresponding to proper parts of motor: model of winding object, model of mechanical part object and model of electromechanical part object. Analysed dependencies between mechanical quantities in both rotating and linear motor used to develop model. Calculated results: force developed by linear induction motor, speed, currents of all phase windings of inductor and secondary and other parameters are obtained in form of graphs. Ill. 5, bibl. 13 ( in English; summaries in Lithuanian, English and Russian).

### **P. Ринкявичене, А. Петровас. Модель линейного асинхронного электропривода // Электроника и электротехника. - Kaunas: Technologija, 2004. – № 2(51). - P. 25-28.**

В статье рассматривается математическая модель линейного асинхронного электропривода и на этой основе разработанная программа для исследования динамических режимов линейного асинхронного электропривода. Разработанная программа позволяет исследовать переходные процессы электропривода с двигателями линейного и вращательного движения при симметричных и не симметричных напряжениях питания, при одинаковых или разных обмоточных параметрах фазных обмоток. Выведена формула для расчёта развиваемого двигателем момента или силы. Модель линейного двигателя разработана как совокупность моделей объектов, соответствующих различным частям двигателя. Приводятся схемы моделей объектов. Анализируются зависимости механических параметров этих двигателей. Результаты моделирования: усилие, развиваемое двигателем, токи всех обмоток индуктора и вторичного элемента и другие параметры получаются в графической форме. Ил. 5, библи. 13 (на английском языке, рефераты на литовском, английском и русском яз.)