

New technologies demonstrated at Formula Electric and Hybrid Italy 2008

Giampiero Brusaglino¹, Giuseppe Buja², Massimiliana Carello³, Antonio Paolo Carlucci⁴
Christopher H. Onder⁵ Monica Razzetti⁶

¹ATA - Associazione Tecnica dell'Automobile, Orbassano (Torino), Italy – giampiero.brusaglino@crf.it

²Università di Padova, Department of Electrical Engineering, Padova, Italy – giuseppe.buja@unipd.it

³Politecnico di Torino, Dipartimento di Meccanica, Torino, Italy – massimiliana.carello@polito.it

⁴Università del Salento, Facoltà di Ingegneria CREA-Centrro Ricerca Energia e Ambiente, Italy – paolo.carlucci@unile.it

⁵Swiss Federal Institute of Technology Zurich, Measurement and Control Laboratory – onder@ethz.ch

⁶ATA – Associazione Tecnica dell'Automobile, Orbassano (Torino), Italy – monica.razzetti@crf.it

EVS-24 International Electric Vehicle Symposium
Stavanger, Norway, May 13th-16th, 2009

Abstract

From 1 to 3 October 2008 the Formula Electric and Hybrid Italy took place in the Safety Testing Center of Fiat Group Automobiles in Orbassano (TO), Italy.

This fourth edition of Formula EHI, an international competitive demonstration of research outcomes from university student teams, has brought to the attention of the public and of the industry new technologies and innovative applications in the area of the systems addressing the ecological mobility. Teams from five European countries were the protagonists of the event. Several projects, components, systems and concept have been presented, related to advanced technologies for battery electric, hybrid and fuel cell vehicles. New technology hybrid, fuel cell and electric vehicles took part to the dynamic test on track for the evaluation of energy efficiency performance and dynamic behaviour. The 2008 event was a further step of the editions of Formula TECH held in the previous years and offered a benchmarking overview of the progress of the technology in the field of electrically propelled vehicles.

Keywords: electric drive, hybrid, scooter, fuel cell

1 Introduction

The development of sustainable technology for ecological vehicles based on electric propulsion, can take substantial benefits from the coordinated efforts in innovation of Academic and Industrial World.

Results of their actions should be brought to the public attention, to generate the culture on ecological vehicles and to stimulate the interest for their development and diffusion.

Formula Electric and Hybrid Italy is an event dedicated to the results of student activities in innovative technologies, which is in line with these objectives [1].

Meeting Academic Institutions and Industry is a profitable opportunity to promote the transfer of

research results, to put in evidence further research needs and to stimulate a cross fertilisation of initiatives among University teams.

Formula Electric and Hybrid Italy is addressing these objectives through a worldwide participation of University teams, sponsoring Industries, Research Institutions and Public Audience.

Students and young engineers are encouraged and stimulated by this challenging competitive event to produce their best performance in the innovation technology for the sustainable future mobility.

This type of event is a benchmark of the technology evolution over a variety of vehicle types and systems and of the relevant trends of development.

The annual sequence of the events allows to progressively update the state of the art for the various types of ecological mobility means and systems and to identify the future ways of development opportunities.

2 The competition structure

The Formula Electric and Hybrid Italy (EHI) is a competitive event aimed to demonstrate research results of the Academic world in the field of ecological technologies, which can contribute to the establishment of a rational transportation system addressing the management of the energy resources and the conservation of environmental quality.

A part of the goal is to address the industry attention to new solutions in this field, suitable to be transferred to the engineering and industrial development process. Another scope is to stimulate and activate exchange of information and contacts among Academic Institutions and relevant supportive industries about these new and socially beneficial technologies.

A final aim is to promote and contribute to the diffusion of the culture of electric and hybrid vehicles and to encourage industries and users to the development and the acceptance of these environment and energy conscious vehicles.

The attention of the Formula EHI and the evaluation of the merits of the research products demonstrated by the participants are addressed to the following aspects:

- Energy effectiveness in urban mission
- Dynamic response in practical operation
- Environmental and utilisation features
- Innovation level
- Industrial development potential

The October 2008 event has enriched the frame of the technologies, which were presented by the university teams in the previous editions.

Three classes of technology research products were invited to the competition:

Class 1 – Four wheel car, single seat, formula style body, equipped with battery electric, hybrid or fuel cell propulsion systems

Class 2 – Other types of vehicles, including two or three or four wheel vehicles, without formula constraints, with the same types of system as above

Class 3 – Vehicle concepts, systems, components and projects dealing with electric and hybrid technologies.

The competition deployment was divided, as in the previous editions, in static presentation and dynamic events.

The evaluations were operated by an expert jury and the scoring was performed according to the figure of merits related to previously mentioned aspects

The dynamic events were performed on test track, according to rules basically consistent with those of U.S. Formula Hybrid:

- Acceleration (time to reach 75 m on flat straight line);
- endurance, to test overall performance and reliability;
- energy consumption.
- autocross, to test handling and manoeuvrability;
- pursuit test, for a direct competition among the participants.

Teams of the following Institutions participated to the event:

- Swiss Federal Institute of Technology Zurich, with a plug-in hybrid sport car
- Moscow University, with a hybrid vehicle project
- Vrije Universiteit Brussel, with a hybrid vehicle project
- University of Roma La Sapienza, with a battery electric vehicle and a hybrid car
- Politecnico of Torino, with a fuel cell car and with a hybrid system project
- University of Terrassa (Spain), with a hybrid system project
- University of Marche (Italy), with a battery electric vehicle
- University of Salento (Italy), with an electric-solar vehicle
- University of Padova, with a tilting body 3 wheel vehicle.

A description of participant vehicles to the dynamic events is presented in the following paragraph.

3 New technology vehicles

3.1 Hyb-alpha, by ETH Zurich Team

Formula Electric and Hybrid Italy objectives, addressing innovation and energy efficiency, in addition to operating performance, were considered, by ETH Zurich Team, consistent with its aim to develop a sport car with new power train and demonstrate the potential of new propulsion systems.

The car was developed and realized by students of the Mechanical and Electrical Engineering Department of ETH supported by students of the University of Applied Sciences and Arts Luzern and by many other people from within ETH and also from industrial partners [2].

The power train

The power-train of Hyb-alpha consists of a 250 cm³, single cylinder, 4 stroke gasoline engine, that is connected via a clutch and a vibration damper to the output shaft of a 60 kW electric motor. In parallel operation mode this power train can deliver more than 100kW to the shaft. A gearbox with an integrated limited slip differential connects the this shaft to the wheels. The kinetic energy of the vehicle is recuperated when braking with the electric motor used as

generator and stored in batteries with a maximum charge of 5 kW. (see fig.1)

The electric motor is permanently connected to the wheels. The combustion engine serves, to a greater or lesser extent, as a range extender and has very limited torque and power. However, if it can be permanently operated at the optimal load and efficiency, it can significantly support the batteries. For low vehicle speeds, the combustion engine is disengaged by a centrifugal clutch. Although being a parallel hybrid, the control strategy of the system is closer to one of a series hybrid, i.e. using the combustion engine in the majority of cases as range extender.

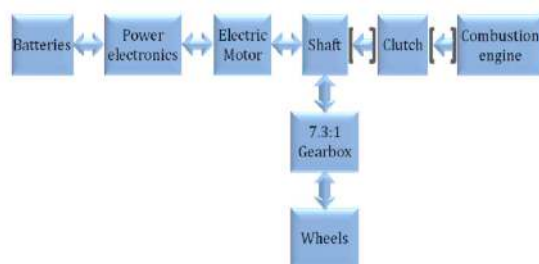

Fig.1: Energy flow chart of the hybrid system

Electric Motor

A synchronous permanent magnet 3 phase motor, the HSM 6.17.12 of the Swiss company Brusa Electronics was selected, considering in particular the drive torque, the recuperation brake torque and the efficiency.

Fig.2 shows the specifications and Fig.3 the torque, power and efficiency versus speed of the motor.

Nominal power	42 kW
Power during 30 s	95 kW
Max speed	11'000 rpm
nominal torque	85 Nm
Max torque during 30s	235 Nm
Nominal Voltage	370 V
Max voltage	440 V
Nominal current	120 A
Max current	230 A
Efficiency	> 96% for full-load and speed > 2000rpm

Fig.2: Specifications of the electric motor

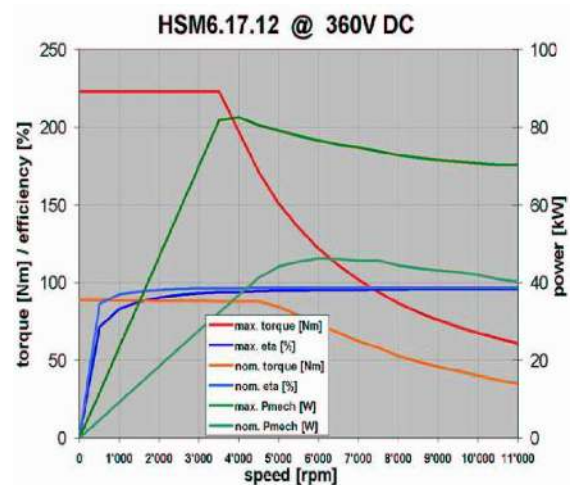

Fig.3: Torque, power and efficiency of the electric motor versus speed

Combustion Engine

Out of various possibilities, the Swissauto Wenko AG, 250 cm³, one cylinder four stroke engine was chosen, because all engine specification were available and because of the lowest fuel consumption (roller bearing at all bearing positions, optimised lubrication, optimised cooling), with further other advantages.

The engine had to be modified for the new Hyb- α hybrid concept.

The original engine has a top speed of over 10'000 rpm. However, the maximum speed of 7'000 rpm is necessary for the hybrid drive only. Hence, a modified camshaft was provided by Swissauto in order to optimize the gas exchange for the new boundary conditions.

- The engine is originally fitted with a carburetor. To have full control of the engine, and to be able to adjust the air/fuel ratio and the ignition timing in every operating point individually, the engine was re-equipped with an electronic fuel injection and ignition, using the WALBRO engine control unit, as well as with an electronic throttle actuator. Additional sensors for the following measurement variables had to be installed: Intake manifold pressure, temperature of the intake air, engine speed, TDC of the crankshaft, air/fuel ratio, and temperature in the exhaust.

To comply with the competition rules, the engine has to be equipped with a restrictor of 12.9 mm diameter. This yields in a strongly reduced air flow into the intake manifold. Hence, reduced engine performance results from this limitation. To increase the reduced torque, a

pressure recovery within a Laval nozzle downstream the restrictor was realized. Since the engine is a one cylinder four stroke engine, strongly varying air flow is expected. Thus an intake manifold with a volume of 4 liters is chosen to damp the air flow variations.

Since the electric motor is permanently connected to the rear-wheels, the combustion engine can be started simply by closing the clutch between the ICE and the electric motor, while en route. Therefore, the electric starter can be omitted.

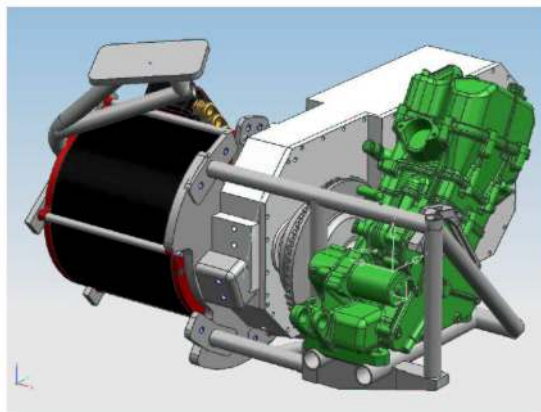

Fig.5: Assembled power train

Batteries

There are many criteria for choosing the battery type: power density, energy density, availability, price and safety.

Lithium Manganese Oxide cell of the size 18650 was chosen, featuring energy density of 110 Wh/kg and power density of 1.7 kW/kg.

Compared to Lithium-ion polymer, Lithium Manganese Oxide has an energy density, which is approximately 30% lower.

However, Lithium-ion polymer batteries can chemically react, if they are overstressed or mechanically damaged.

The used manganese cell is inherently fail-safe unless it is mechanically destroyed.

Another battery type with comparable energy density and higher peak performance is the Lithium Iron Phosphate battery. The drawback of these cells is, that they have to be balanced (the voltage of every cell has to be controlled individually), which is not the case for the Lithium Manganese Oxide cells.

A configuration of 100 cells in series and 10 cells in parallel is used. This results in a nominal voltage of 370V and a typical maximum current of 100A.

The control of the complete power train is custom made by the students and runs on a rapid prototyping computer.

Several control loops coordinate all components and optimise safety, efficiency and drivability of the vehicle.

This new type of hybrid system has a large potential to be applied and used in conventional vehicles.

Fig.6 shows the space frame of the vehicle, with the stiffening structure required for the safe integration of batteries and the power train.

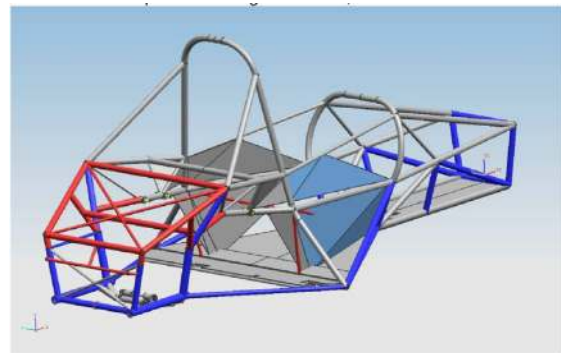

Fig.6: Space frame of the car.

The picture below shows the car presented by the ETH Zurich team for the competition at Fiat Safety Center during the Award Ceremony in which it was awarded with the first prize in the Class 1.



3.2 IDRA 08 and the Team H2politO

IDRA 08 is the first low consumption prototype developed, assembled and tested by the Team H2politO a student team of the Politecnico of Torino. Starting from an "idea" the vehicle has been projected, designed and realised by twelve engineering students.

Essentiality, minimalism, easy to use were the basic criteria of the whole project.

The prototype has three wheels: one rear wheels and two front wheels.

The propulsion system has been realised with a hydrogen fuel cell (1 kW), combined with a high efficiency brushed electric motor (0,2 kW).

The fuel cell is supplied with hydrogen stocked at 200 bar.

The transmission is chain type (figure 1) and it allows to connect the electric motor to the driving rear wheel.



Figure 7 – Transmission system

The study of the power system was particularly focused on the fuel cell (figure 2) and electric motor integration, studying an easy system to reduce losses of energy in the fuel cell and tuning the power train consumption to the race strategy.

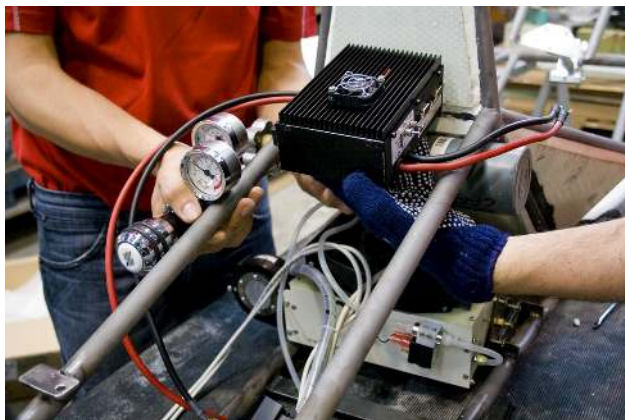

Figure 8 – Fuel cell system

The framework was made on welded steel tubes 25 CrMo4. Honeycomb panels (aluminium sheets and glass fiber reinforcements) were used as supports to divide the engine compartment. A specific support for the driver was realised.

The steering system is simple, light and safe and gives a wide range of possible regulation, that allows mechanics and the driver to obtain optimal driving performance.

Particular attention was paid to ergonomics. Everything was designed to give accessibility to commands with a minimum driver effort.



In the above picture you can see particular: framework, steering system, wheels, power train, all ready the first test on the road!

To verify the driver safety, many numeric simulations (like crash-tests) were performed on a computer, focusing on frontal and lateral crashes and vehicle overtuning.

The aerodynamics was studied to reduce the resistance to the motion, using the aerodynamic flows to create lift and the final vehicle shape has been obtained using computational fluid dynamic programme.

The coefficient C_x obtained with simulation procedure and experimental tests made on wind tunnel are 0.237 and 0.26 respectively.

Special attention was also given to the ventilation of the cockpit and the engine compartment.

The bodywork is in carbon fibre to minimize the weight and it was studied both for aerodynamic purposes and to reach an aggressive and good looking design.

The production process helped to obtain an excellent surface finishing.

The covering is made of polycarbonate and was studied to reflect the solar light and to allow a good driver's visibility. This system ensures an easy and quick opening operation and maximum safe getting out the prototype.

The braking system is composed by two hydraulic circuits separated between front and rear, with a disk brake each wheel.

The system was designed with a compact layout to have less clutter and weight; it has high performance and it is linked to the frame through ultra-light bolts and titan screws.

The rim is custom-made and completely realized of carbon fibre, material that gives it a significant lightness (the weight is 0.4 kg) without reducing its resistance and its structural stiffness.

The innovative realization allowed both to have a correct held of the tyre pressurized at 6.5 bar and to obtain the rim in just one piece, avoiding the use of heavy structural glues.

Also the hubs, made of anodised aluminium, were designed especially for the application on the vehicle. Inside them, the bearings are mounted with a properly studied process, to have minimum friction and reduce the weight.

The prototype is shown in figure 10.



Figure 10 – Final IDRA08 on the test track

The prototype has a weight of 65 kg, a length of 3 m, a wheel track of 0.8 m and a height of 0.65m.

IDRA08 has participated at the Shell Eco-marathon 2008 on Nogaro circuit (France) obtaining a fuel economy of 940 km/l with the equivalent energy of one litre of petrol.

IDRA has then participated at Formula EHI (Electric and Hybrid Italy) at Fiat Safety Centre, Orbassano (Turin). In this contest, the prototypes confront themselves with different kind of challenges: fuel consumption, climb ability test, handling, performance and pursuit. Even if its technical characteristics favour the low consumption of energy, it was possible to evaluate the dynamic behaviour of IDRA08.

Other than joy for the clear victory in the endurance test, IDRA08 impressed for its agility among the cones on the race track for the excellent brakes even nearer to the limit point before curves, for its behaviour on the racetrack in spite of the disconnection of the asphalt, lateral accelerations and transfer of load.

The good capacity of the pilot and the hard and important work of all Team has allowed to obtain the third prize in the category 2 (figure 5)

3.3 VEUS 08

Air pollution and greenhouse gases emissions can be largely attributed to the systems of transportation and mobility, key element for passengers and/or goods movement. Concerning transportation, “Mobility can be defined as the ability to move and put in contact goods and people in space and time”. This ability is crucial for the socio-economic development of a country. In fact, transportation allows people to access goods and services, creates employment opportunities, ensures the optimal movement of goods, supporting local development processes. In 1990 the total emission levels of carbon dioxide produced by the transport sector was

about 1.25 billion tons, about one fifth of total emissions coming from the use of fossil fuels. With the European Council of 8 - 9 March 2007, the European Union agreed to reduce emissions by 30% compared to 1990 emissions, with the target of reduction of 60-80 % within 2050.

With current policies on energy and transportation, the emission levels of CO₂ in EU, instead of decreasing, will increase of 5% by 2030.

The Commission also considers that the most significant energy savings can be achieved nowadays only in certain areas:

- the tertiary sector (residential and commercial), with an estimated potential reduction of 27% and 30%;
- in manufacturing, with possible savings around 25%;
- in the transport sector, with an estimated consumption reduction of 26%.

The idea of the VEUS 08 project was born in the Faculty of Engineering of the University of Salento, in order to meet these goals.

VEUS 08 (Solar Urban Electric Vehicle) is a photovoltaic-electric vehicle designed to be used exclusively in urban area, with the purpose of reducing energy consumption and pollution specially in big cities. It is exclusively electrically powered; moreover, the battery recharge is performed, when the car is moving, thanks to several solar panels positioned above the whole mainbody, while, when stopping, to the combined action of the solar panels and the electric network.

The car was created to promote the use of renewable energy and is so innovative because most solar cars are designed only to be used under controlled conditions on motor - racing tracks. On the contrary, the goal of VEUS 08 project is to demonstrate a practical use of solar technology; in this way, manufacturers can adapt it to mass production of future vehicles.

This is like an economy car limited only to the short-haul urban action; it is in fact designed for an autonomy of 100 km and with a limitation of the maximum speed to 50 km/h.

Carriageway	1,44 m
Rate	1,80 m
Width	1,80 m
Length	2,50 m
Height	1,40 m
Passenger	2
Load	740 kg

The electric motor used is a series-characteristic motor with a rated power of 6.8 kW. The engine power depends on the speed (v) and the slope of the carriageway roads (p); in our application, it has been calculated assuming an average speed of 40-45 km/h (with maximum speeds between 55-60 km/h which can be reached only on city streets-speed) and considering a maximum uphill distance (with slopes of more than 5%) and on flat roads (slopes less than 3%).

The total capacity of the battery pack has been determined based on the number of days of autonomy wanted to be ensured for the vehicle and according to the maximum daily energy required. With 12 batteries (6 in the rear of the car and 6 in the front) a system at 48 V and 345 Ah was obtained.

With this configuration, the car can be driven for 95 km average on roads with slope $p \leq 3\%$ and for about 5 km on roads with $p > 3\%$, or 90 km on roads with $p \leq 3\%$, and 10 km on roads with $p > 3\%$ at the average speed of about 40 km/h.

The batteries are recharged connecting the vehicle to the domestic net (3.3 kW) and by the contribution of solar panels placed on the mainbody.

The impact of the car on electric power consumption and emission of greenhouse gases has been estimated, if all the power needed for charging the batteries was produced by thermal power stations (combined cycle fueled by natural gas, conventional cycle steam fed fossil fuels); all of this was done considering data available on the literature on pollutant emissions of vehicles in cities, and considering also the pollutant emission levels (in terms of CO, SOx, NOx, heavy metals, etc. .) produced by a thermal power fed with conventional fuels (natural gas, coal, fuel oil, etc.). These levels of exhaust gases have been compared with those produced by internal combustion engines currently equipping the cars.

Figure 11 – Estimated emissions

The estimated emissions from power plants (Fig. 11) are much lower than those obtained with cars in urban conditions, whereas the complete refilling of the car takes about 23 kWh, taken from the electric network.

Finally, adding the contribution from the photovoltaic generator to recharge the batteries, the cost per kilometer is equal to 0.036 €/km for the VEUS, compared to the average value of € 0.0762 / km calculated for the current cars, with a saving of over 50% per kilometer.

Energy flows

The power needed for traction is provided exclusively by the batteries placed in the vehicle. The recharging process of the batteries is obtained by connecting the vehicle to the electric network (3.3 kW) and the contribution of solar panels placed on the mainbody.

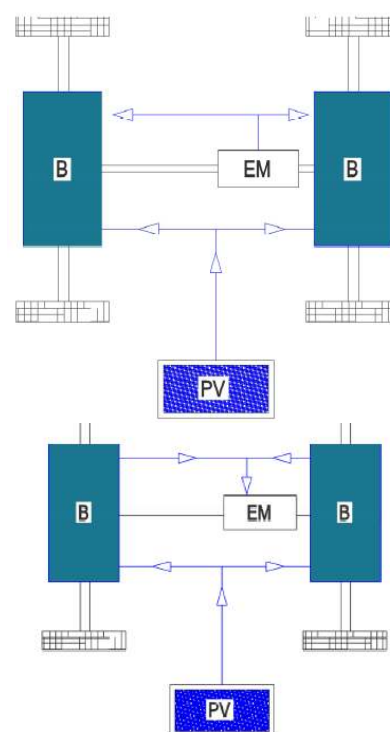

Figure 12 – Energy Flows a) The car is moving;
b) regenerative braking

When the car is moving, the two sources of energy are the batteries and the photovoltaic panels (which recharge the batteries). During braking, it is possible to recover the kinetic energy thanks to regenerative braking.

For the preliminary estimation of solar energy that can be collected by the photovoltaic panels, the values of global solar radiation at ground level and on horizontal and inclined surface extracted from ENEA maps has been considered.

The technical characteristics of the generator are:

- ✓ Max power: 159 W at 1.000 W/m² and 25° C (7 panel 7 W, 4 panel 14 W and 2 panel 27 W)
- ✓ Max current: 11,25 A
- ✓ Voltage: 15 V
- ✓ Load: 14,06 kg
- ✓ Surface solar panel: 4,01 m²

The energy (estimated) produced by the panels is obtained by summing two contributions:

- The energy produced during the travelling period: E_d
- The energy produced during the parking period: E_p

The graphs describe the annual trend of energy output from the generator and power provided during the travel.

Of course, this energy (and the power) is higher during the summer months when the solar radiation values are higher, reaching the maximum of 45 W (July).

It is estimated an average solar contribution of about 3%.

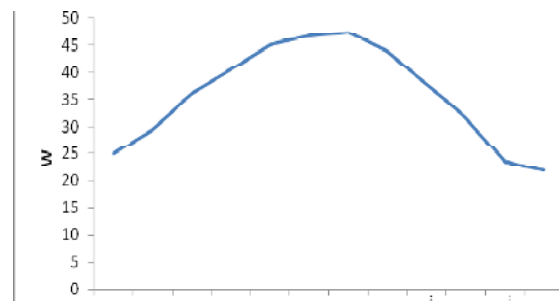
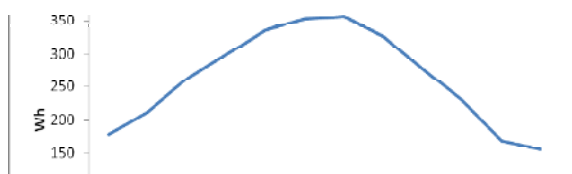

Figure 13 – Solar contribution

Conclusions

The goal of the research team of the Faculty of Engineering is to realize an environmentally sustainable car designed for the city, being this car small and easily maneuverable.

In addition to the total lack of emissions during the driving phase, it should be highlighted the cost of fuel, estimated at less than 3.50 euro, which will allow to cover 100 km at an average speed of 50 km/h (that cost is significantly reduced if the electric power needed is produced from renewable sources).



The electric vehicle can therefore be considered an "environmental vehicle" at the local level and to users, since it does not emit exhaust gases. However, this is not true taking into account the whole energy production process. The recycling of used batteries as well as the production of electricity to recharge the batteries must be taken into account too.

In the worst cases, this electric power is produced from fossil fuels that release pollutants into the atmosphere. Therefore, this electric vehicle, as well as every electric vehicle, can be classified as clean only if energy required for the office should be produced from renewable energy sources (solar, wind, hydroelectric, etc.);

but the basic advantage is the zero pollution in the site of utilization, that is mainly in urban areas, where the life and the activity of the man mostly takes place.

3.4 Wheel motor of E-SNAKE

The design of the electric propulsion system of the E-snake started in the middle of the 2006 and was relying on an existing motorcycle-derived three-wheel vehicle. The mechanical layout of the vehicle consists of a tilting front module with one wheel, a non-tilting rear module with two wheels of very narrow track, and a four-bar linkage connecting the two modules. A detailed description of the mechanical layout can be found in [1].

The electric propulsion system of the E-snake is characterized by three outstanding features, namely the lithium-ion battery with the relevant management system, the by-wire riding for conditioning the handlebar commands, and the in-wheel motorization. Regarding the latter feature, two equal wheel motors -one for each rear wheel- propel the vehicle.

The concept of wheel-motor dates back to the beginning of the last century. In 1902 F.Porsche, while working at Lohner Co. of Vienna, devised an electric motor to be built-in into the wheels of a car. Compared to the traditional electric powertrains, the in-wheel motorization exhibits distinct advantages. The main advantage is that no differential, axle shaft and, possibly, gear is needed, thereby reducing complexity, weight and room of the powertrain, and improving its efficiency. The main shortcomings are the addition to the unsprung mass of the vehicle and the mechanical and thermal solicitations experienced by the motors. The recent advancements in the electric motor technology has allowed the manufacturing of compact and reliable wheel motors of low-medium size that develop torques up to a few tens of Nm and are employed in scooters and motorized bicycles. Efforts are being held to set up wheel motors of larger size to propel the cars and some prototypes have appeared.

The wheel motor used in the E-snake is a three-phase permanent magnet machines of brushless dc type, i.e. with the back emf of trapezoidal waveform. Differently from the conventional arrangement, the wheel motor has an inner stator and an outer rotor. The stator contains concentrated windings and is fastened to the hub of the wheel. The rotor contains the rare earth

permanent magnets (Sm-Co) and constitutes the rim of the wheel. The motor has a radial-flux structure in order to achieve high field intensity across the stator windings and zero magnetic force between the rotor and the stator.

Each motor is fed by a separate inverter with Mosfet transistors. Two inverter legs are conducting at a time, where the feeding sequence of the motor phases is dictated by Hall sensors placed on the stator. The resulting brushless dc drive imposes currents of basic square-shaped waveform into the phases.

The control system of the drive operates in the voltage mode with battery current limitation. The voltage reference is reproduced at the inverter output by varying the duty-cycle δ of the transistors, being their switching frequency of 14 kHz.

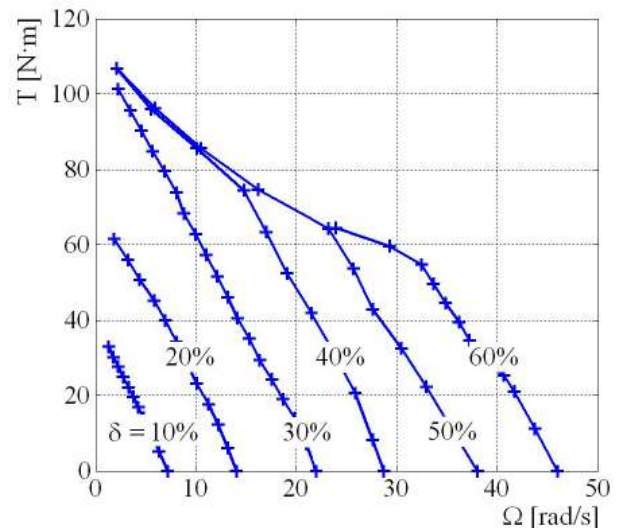

Torque- speed characteristic of the wheel motor

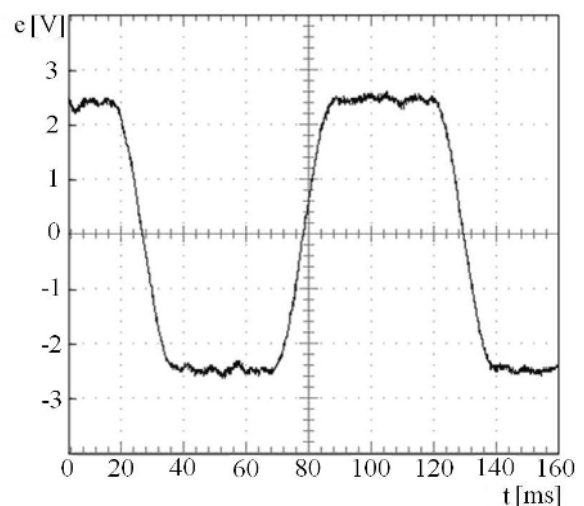

Brushless dc motor back emf at 75 rpm

A capacitor filter at the inverter input makes the current drawn by the battery nearly continuous. The control system detects this current and, when it exceeds a settled limit, manipulates the duty-cycle so as to clamp the current. This implies that the torque-speed characteristics of the drive are linear for small torques and merge into an hyperbolic-like curve for high torques, which are requested especially at low speeds. This behavior helps riding the vehicle when starting and climbing. The control system, moreover, has an input termed torque boost that increases more than two times the settled limit of the battery current thus doubling the torque developed by the drive at a given speed. The torque boost is entered by the handlebar and is enabled for a few tens of seconds.

The main data of the two brushless dc drives with wheel motor equipping the E-snake are reported in Tab. 1. Note that for a motor rotation of 620 rpm, the speed of the vehicle is about 47 km/h.

Tab. 1. Main data of the brushless dc drives with wheel motor

Rated voltage	48 V
Pole pairs	8
Rated dc link current	45 A
Torque at 620 rpm	30 N·m
Peak dc link current	100 A
Peak torque at 340 rpm	90 N·m
Weight (with tire)	14 kg
Wheel diameter	10 inches
Outer wheel radius with tire	0.2 m



Inner view of the wheel motor with pole direction

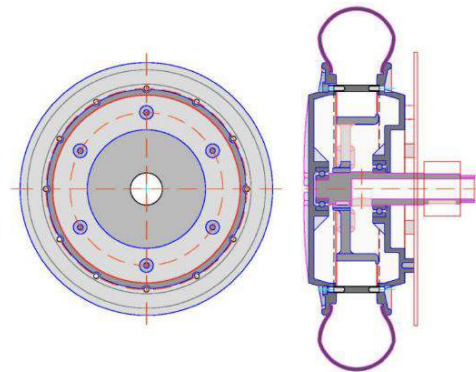

Wheel motor front and lateral views



Three-wheel vehicle rendering

4 Technology outcomes

The presentation of new technology vehicles has shown various spin off to new developments and implementation at industrial level.

From Hyb- alpha:

- the operational demonstration of the hybrid plug-in concept, with the feeding of the vehicle with two energy sources, fuel and electricity and the consequent benefits at the level of primary energy consumption
- the demonstration of the performance enhancement of the car due to the hybrid systems, keeping at the same time a good energy economy level
- the hybrid systems concept based on the use of a permanent magnet motor with very high efficiency and high constant power field, complemented by two clutches, for the functions of speed variations.

From IDRA 08:

- concepts and solutions for a very energy efficient vehicle systems, including weight, aerodynamics and rolling resistant aspects
- operation of a fuel cell systems in practical use, with demonstration of reliability and control capability
- study of ergonomics for easy and comfortable management of the vehicle.

From VEUS 08:

- the application of flexible structured solar photovoltaic panels with appropriate distribution on the car body
- the integration of the solar systems with the electric storage system.

From E-SNAKE:

- the in-wheel motorization with two permanent magnet motors directly integrated and the relevant electronic control
- the Lithium batteries and the related management systems
- the by-wire riding

The presentation of the projects produced by international teams brought a valuable contribution with indication of development trends, which are promisingly addressing new realisations for future Formula EHI editions.

It is worthy to mention the hybrid vehicle projects of the Vrije Univeriteit Brussel, of Moscow University, of Univeristy of Terrassa and University of Roma La Sapienza, which are intended to give a further development, with realisation next year.

Further development of battery electric vehicles were objects of cars presented by Univeristy of Roma la Sapienza and University of Marche.

5 Conclusion

The fourth edition of Formula EHI brought to be attention and consideration of the actors involved in the field of electrically propelled vehicles new outcomes in technology validations and technical achievements in the three domains of electric, hybrid and fuel cell vehicles.

The set up of this type of vehicles takes benefits from the integration of various technology elements, which can take profit from the cross fertilized validation and development.

This is what is been achieve by the result of this demonstrations, putting at the disposition of the engineers validation elements and new solutions hints applicable to different kinds of vehicle.

This type of event is considered to be a strong stimulus for an international cooperation among University students, Industry and Research Institutions to progressively enlarge the asset and knowledge of the technology for environment friendly vehicles.

References

- [1] G.Brusaglino, A.Doria, P.Guglielmi, L.Martellucci and M.Razzetti, "Innovation for ecological sustainable mobility in formula Electric & Hibrid Italy 2007", Proceedings of 3rd European Ele-Drive Transportation Conference (EET), 2008, pp.....
- [2] Guzzella Lino, Sciarretta Antonio: "Vehicle Propulsion Systems, Introduction to

Modeling and Optimization", 2nd Edition, Springer, 2007

- [3] M.Bertoluzzo, G.Buja and R.Pavoni, "Characterization and Improved Control of a Brushless DC Drive with In-Wheel Motor", Proceedings of 13th International Power Electronics and Motion Control Conference (EPE-PEMC), 2008, pp. 1514-1519
- [4] S.Wu, L.Song and S.Chei, "Study on improving the performance of permanent magnet wheel motor for the electric vehicle application", IEEE Transactions on magnetic, Vol. 43, No. 1, pp. 438-442, January 2007

Authors

Giampiero Brusaglino graduated at Politecnico di Torino, Italy, in Electrical Engineering and in Aeronautical Engineering. He was Vice Director at Centro Ricerche Fiat. He has been President of A.V.E.R.E. and coordinator of the EUCAR Interest Group Electric Vehicles. He is Head of the CUNA Commission Electric Vehicles, Chairman of the Technical Committee CEI-CIVES and Head of the Italian Delegation UNI-CUNA.



Dr. Christopher H. Onder is senior scientist and lecturer at the Measurement and Control Laboratory, ETH Zurich. Research interests: modelling and control of automotive systems, highly dynamic testbench equipment, model-based robust control



He graduated with honours in Materials Engineering at the University of Lecce in 2000. In 2004 he achieved the PhD in "Energetic Systems and Environment" at the same University, with a dissertation on the analysis of alternative injection strategies for new generation Diesel engines. He collaborated as visiting scholar in a project for the application of electrospray technology to the automotive field at the University of Illinois at Urbana-Champaign. It is Author of many national and international publications. Interest



fields: analysis of combustion and non intrusive diagnostic in ICE, electrospays, gaseous fuels in ICE, energetic systems for sustainable mobility.

Giuseppe Buja is a full professor of power electronics and the head of the Laboratory of Electric Systems for Automation and Automotive at the Department of Electric Engineering of the University of Padova, Italy. His scientific interests range from power electronics to fieldbuses and are documented by journal and conference papers. In recent times he has directed research projects on by-wire systems and hybrid/electric vehicles. He is a recipient of the IEEE-Industrial Electronics Society Eugene Mittelmann Achievement Award “to recognize outstanding technical contributions to the field of Industrial Electronics”.



Monica Razzetti works in ATA from 2000; now she is the Formula Electric & Hybrid Italy Manager and she is responsible for the administration and management of ATA Members.