

Engineering
Electrical Engineering fields

Okayama University

Year 1996

New trends in active filters for improving
power quality

Hirofumi Akagi
Okayama University

This paper is posted at eScholarship@OUDIR : Okayama University Digital Information
Repository.

http://escholarship.lib.okayama-u.ac.jp/electrical_engineering/62

New Trends in Active Filters for Improving Power Quality

Hirofumi Akagi, Senior Member, IEEE
Department of Electrical Engineering
Okayama University
Okayama-city, 700 Japan

Abstract—Since their basic compensation principles were proposed around 1970, active filters have been studied by many researchers and engineers aiming to put them into practical applications. Shunt active filters for harmonic compensation with or without reactive power compensation, flicker compensation or voltage regulation have been put on a commercial base in Japan, and their rating or capacity has ranged from 50kVA to 60MVA at present. In near future, the term of active filters will cover a much wider sense than that of active filters in the 1970's did. The function of active filters will be expanded from voltage flicker compensation or voltage regulation into power quality improvement for power distribution systems as the capacity of active filters becomes larger. This paper describes present states of the active filters based on state-of-the-art power electronics technology, and their future prospects toward the 21st century, including the personal view and expectation of the author.

I. INTRODUCTION

A number of low-power electronic-based appliances such as TV sets, personal computers, and adjustable speed heat pumps generate a large amount of harmonic current in power systems even though a single low-power electronic-based appliance, in which a single-phase diode rectifier with a dc link capacitor is used as utility interface, produces a negligible amount of harmonic current. Three-phase diode or thyristor rectifiers and cycloconverters for industry applications also generate a large amount of harmonic current. Voltage distortion or harmonics resulting from current harmonics produced by power electronic equipment has become a serious problem to be solved in many countries.

The guidelines for harmonic mitigation, announced on Oct. 3, 1994 in Japan, are currently applied on a voluntary basis to keep harmonic levels in check and promote better practices in both power systems and equipment design. In general, individual low-power end-users and high-power consumers are responsible for limiting the current harmonics caused by power electronic equipment, while electric power companies are responsible for limiting voltage harmonics at the point of common coupling in power transmission and distribution systems.

Since the basic principles of active filters were proposed around 1970, attention has been paid to active filters [1]–[6]. The advance of power electronics technology over the last ten years, along with the theory of instantaneous active and reactive power in three-phase circuits which was presented in 1983 [8], has made it possible to put active filters into practical applications, not only for harmonic compensation with or without reactive power compensa-

TABLE I
ANALOGY BETWEEN HARMONIC POLLUTION AND AIR POLLUTION

sources	harmonic pollution	air pollution
unidentified	<ul style="list-style-type: none">• TV sets, and personal computers• adjustable speed heat pumps	<ul style="list-style-type: none">• gasoline-fueled vehicles• diesel-powered vehicles
identified	<ul style="list-style-type: none">• bulk rectifiers• cycloconverters• arc furnaces	<ul style="list-style-type: none">• chemical plants• coal and oil steam power stations

tion [7][11], but also for flicker compensation [12] and voltage regulation of impact drop at the end terminal of a power system servicing the Shinkansen, i.e., the Japanese "bullet" trains [33][34]. Nowadays, more than three hundred shunt active filters consisting of voltage-fed PWM inverters using IGBTs or GTO thyristors are operating properly in Japan, the capacity or rating of which ranges from 50kVA to 60MVA. All of them have been installed by individual high-power consumers on their own premises near harmonic-producing loads. The shunt active filters have presented much more satisfactory filtering characteristics than conventional shunt passive filters and/or static var compensators based on thyristor-controlled reactors.

This paper deals with present states and new trends in active filters for improving power quality of industrial plants and distribution systems. First of all, the latest measured results of voltage harmonics in a power system in Japan are shown every voltage class. Then, classification of active filters is made from their objectives, system configurations, power circuits, and control strategy. Next, a couple of interesting examples of practical applications of active filters are presented with their capacity and objective. Finally, their future prospects toward the 21st century are described with the focus on active filters for damping of harmonic propagation or resonance rather than for harmonic compensation, which will be dispersively installed on power distribution systems by electric power companies.

II. VOLTAGE HARMONICS IN POWER SYSTEMS

A. Harmonic-Producing Loads

Nonlinear loads drawing non-sinusoidal currents from electric utilities are classified into identified and unidentified loads by whether electric utility companies can iden-

TABLE II
VOLTAGE HARMONICS IN A POWER SYSTEM

voltage (kV)		THD	3rd	5th	7th
500	max.	2.4	0.5	2.3	0.0
	min.	1.0	0.2	0.9	0.0
275 ~ 220	max.	3.2	1.1	2.4	0.5
	min.	1.6	0.7	0.8	0.1
187 ~ 154	max.	2.3	0.4	2.4	0.8
	min.	0.9	0.1	0.8	0.0
77 ~ 66	max.	3.2	1.1	2.4	0.5
	min.	1.9	0.7	0.7	0.1
allowable	-	3.0	2.0	2.5	2.0

TABLE III
VOLTAGE HARMONICS IN A DISTRIBUTION SYSTEM OF 6.6kV

area		THD	3rd	5th	7th
residential	max.	4.9	0.5	4.7	1.4
	min.	2.8	0.2	2.6	0.8
commercial & industrial	max.	3.7	0.6	3.4	1.6
	min.	0.8	0.1	0.3	0.5
allowable	-	5.0	3.0	4.0	3.0

tify the point and capacity of harmonic-producing loads on distribution systems. Large capacity diode or thyristor rectifiers, cycloconverters, and arc furnaces installed by high- and medium-voltage consumers are typical identified harmonic-producing loads.

On the other hand, single-phase diode rectifiers with dc link capacitors are representative unidentified harmonic-producing loads, which have been widely used as utility interface in TV sets, personal computers, and so on. Although a single-phase diode rectifier generates a negligible amount of harmonic current, the total amount of harmonic current produced by all the single-phase diode rectifiers has become dominant rather than non-negligible in power distribution systems at present. No one has paid attention to unidentified harmonic-producing loads except for some of the researchers and engineers in power electronics and power engineering, so that the guidelines or regulations for harmonic mitigation would play an important role. Table 1 shows an interesting analogy in unidentified and identified sources between harmonic contamination and air pollution.

B. Voltage Harmonics in a Power System in Japan

Tables 2 and 3 show maximum and minimum values of total harmonic distortion (THD) and voltage harmonics in a typical power system in Japan, which were measured from April 28 to May 9, 1994 [31]. The total harmonic distortion and voltage harmonics in the high-voltage power

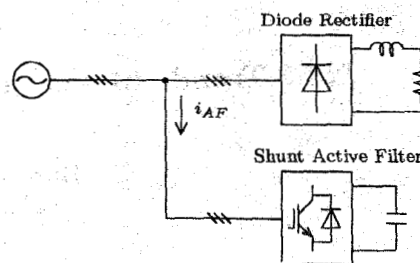

Fig. 1. Shunt active filter standing alone

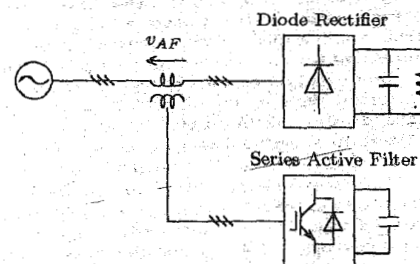

Fig. 2. Series active filter standing alone

system tend to be less than those in the medium-voltage distribution system of 6.6kV. The reason is that an increase of short circuit capacity, which results from the expansion and interlinkage of high-voltage power systems, has made high-voltage systems more stiff. As for the distribution system, the maximum value of the 5th harmonic voltage in a residential area exceeds its allowable level of 4%, and that of the total harmonic distortion approaches its allowable level of 5%. Table 3 suggests that dominant harmonic-producing loads in residential areas of distribution systems are "unidentified" electronic-based appliances such as TV sets.

III. CLASSIFICATION OF ACTIVE FILTERS

Many technical papers and articles related to active filters have been published and various types of active filters have been proposed. Classification of active filters is made from different points of view. Active filters are divided into active ac filters and active dc filters. The active dc filters have been studied to compensate for current and/or voltage harmonics on the dc side of thyristor converters for HVDC systems [13][19][25] and on the dc link of a PWM rectifier/inverter for traction systems [35]. Emphasis, however, is put on the active ac filters in this paper because the term of "active filters" means the active ac filters in many cases at present.

A. Classification from Objectives: Who are responsible for installing active filters?

Active filters for improving power quality are classified into two types of active filters. One is active filters which have already been installed by individual electric power

consumers on their own premises near one or more identified harmonic-producing loads. Another is active filters which will be installed by electric power utilities on their own substations and/or distribution feeders.

The purpose of active filters installed by electric consumers is to compensate for current harmonics, current unbalance or negative-sequence currents, and voltage flickers. On the other hand, the purpose of active filters installed by electric utilities would be to compensate for voltage harmonics at the point of common coupling in distribution systems, and to damp harmonic propagation caused by resonance between line inductors including leakage inductances of distribution transformers and shunt capacitors for improving power factor in power systems.

B. Classification from System Configurations

B.1 Shunt active filters and series active filters

Fig.1 shows a system configuration of a shunt active filter standing alone, which is one of the most basic system configurations. The shunt active filter injects a compensating current into the supply to cancel current harmonics contained on the ac side of a general-purpose thyristor rectifier with a dc link inductor [15][16] or a PWM rectifier with a dc link capacitor for traction systems [30]. The shunt active filter has the capability of damping harmonic propagation between an already-existing passive filter and the supply impedance [11][27]. Fig.2 shows a system configuration of a series active filter standing alone. The series active filter is connected in series with the supply through a matching transformer, so that it is applicable to harmonic compensation for a large capacity diode rectifier with a dc link capacitor. Table 4 shows comparisons between the shunt and series active filters. This concludes that the series active filter has a "dual" relationship in each item with the shunt active filter [23].

B.2 Hybrid active and passive filters

Figs.3, 4 and 5 show three types of hybrid active and passive filters, the major purpose of which is to reduce initial costs and to improve efficiency.

The shunt passive filter consists of one or more tuned LC filters and/or a high-pass filter. Table 5 shows comparisons among the three hybrid filters, in which the active filters are different in function from the passive filters. The combination of shunt active and passive filters has already been applied to harmonic compensation for large capacity cycloconverters for steel mill drives [11]. The combined filters, shown in Fig.4 [18][24][37] and in Fig.5 [20][29][36], will be practically applied in near future, considered prospective alternatives to shunt or series active filters standing alone. Other combined systems of active filters and passive filters or LC circuits have been proposed in [28][32].

B.3 Combination of shunt active filters and series active filters

Fig.6 shows the combination of a shunt active filter and a series active filter [14][38][39]. The major purpose of the

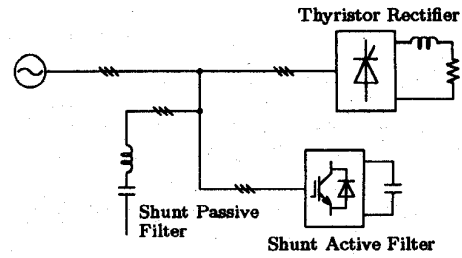

Fig. 3. Combination of shunt active filter and shunt passive filter

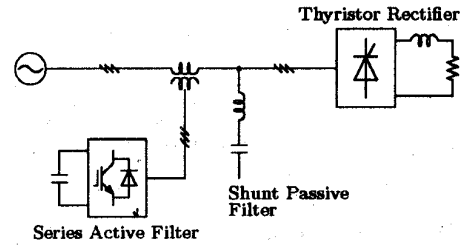

Fig. 4. Combination of series active filter and shunt passive filter

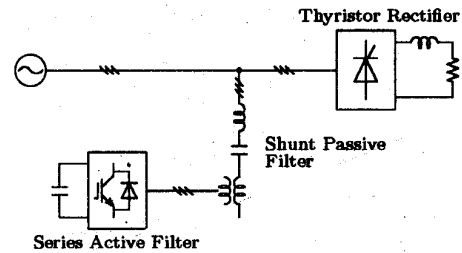

Fig. 5. Active filter connected in series with shunt passive filter

series active filter is harmonic isolation between the sub-transmission system and the distribution system, and voltage regulation as well as voltage flicker and/or imbalance compensation at the point of common coupling (PCC). The main purpose of the shunt active filter is harmonic sink, reactive power compensation and dc link voltage regulation between both active filters.

An example of a basic unified power quality conditioner having the only function of harmonic compensation is taken in the following. The series active filter, which keeps harmonic currents from flowing in and out of the distribution feeders, is controlled to present zero impedance for the fundamental frequency and to act as a resistor with high resistance of G [Ω] for the harmonic frequencies [18]

$$v_{AF} = G \cdot i_{sh}. \quad (1)$$

The shunt active filter, which absorbs harmonic currents generated from the feeders, is controlled to present high impedance for the fundamental frequency and to act as a resistor with low resistance of $1/K$ [Ω] for the harmonic frequencies.

$$i_{AF} = K \cdot v_{sh}. \quad (2)$$

TABLE IV
COMPARISON OF SHUNT AND SERIES ACTIVE FILTERS STANDING ALONE

	shunt active filter	series active filter
system configuration	Figure 1	Figure 2
power circuit of active filter	voltage-fed PWM inverter with current minor loop	voltage-fed PWM inverter without current minor loop
active filter acts as	current source: i_{AF}	voltage source: v_{AF}
harmonic-producing load suitable	diode or thyristor rectifiers with inductive loads, and cycloconverters	large capacity diode rectifiers with capacitive loads
additional function	reactive power compensation	ac voltage regulation
present situation	commercial stage	laboratory level

TABLE V
COMPARISON OF HYBRID ACTIVE AND PASSIVE FILTERS

	shunt active filter plus shunt passive filter	series active filter plus shunt passive filter	series active filter connected in series with shunt passive filter
system configuration	Figure 3	Figure 4	Figure 5
power circuit of active filter	<ul style="list-style-type: none"> voltage-fed PWM inverter with current minor loop 	<ul style="list-style-type: none"> voltage-fed PWM inverter without current minor loop 	<ul style="list-style-type: none"> voltage-fed PWM inverter with or without current minor loop
Function of active filter	<ul style="list-style-type: none"> harmonic compensation 	<ul style="list-style-type: none"> harmonic isolation 	<ul style="list-style-type: none"> harmonic isolation or harmonic compensation
advantages	<ul style="list-style-type: none"> general shunt active filters applicable reactive power controllable 	<ul style="list-style-type: none"> already existing shunt passive filters applicable no harmonic current flowing through active filter 	<ul style="list-style-type: none"> already existing shunt passive filters applicable easy protection of active filter
problems or issues	<ul style="list-style-type: none"> share compensation in frequency domain between active filter and passive filter 	<ul style="list-style-type: none"> difficult to protect active filter against overcurrent no reactive power control 	<ul style="list-style-type: none"> no reactive power control
present situation	<ul style="list-style-type: none"> commercial stage 	<ul style="list-style-type: none"> field testing 	<ul style="list-style-type: none"> coming into market

TABLE VI
SHUNT ACTIVE FILTERS ON COMMERCIAL BASE IN JAPAN

objective	rating	switching devices	applications
harmonic compensation with or without reactive power compensation	50kVA ~ 1000kVA	IGBTs	diode or thyristor rectifiers and cycloconverters for industry
flicker compensation	5MVA ~ 50MVA	GTO thyristors	arc furnaces
voltage regulation	40MVA ~ 60MVA	GTO thyristors	Sinkansen (the Japanese "bullet" trains)

In (1) and (2), i_{sh} and v_{sh} are the harmonic current and voltage which are extracted from the detected supply current i_S and bus voltage v_S by calculation in the time-domain, and G and K are the feedback gains of the series and shunt active filters, respectively. Other feedback or feedforward control loops would be added to (1) and (2) in

order to achieve reactive power control, voltage flicker and imbalance compensation, and so on.

The combination of the series and shunt active filters is named the "unified power quality conditioner" in this paper, associated with the unified power flow controller which has been proposed by Gyugyi [22]. However, the unified

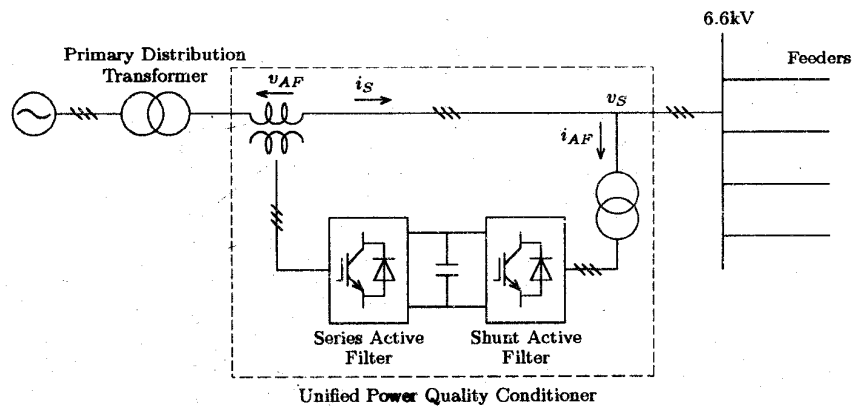

Fig. 6. Combination of series active filter and shunt active filter

power quality conditioner for distribution systems is quite different in operation, purpose, and control strategy from the unified power flow controller for transmission systems.

C. Classification from Power Circuits

There are two types of power circuits in active filters; a voltage-fed PWM inverter and a current-fed PWM inverter. These are the same in the power circuits as those for ac motor drives. They are, however, different in their behavior because active filters act as non-sinusoidal current or voltage sources. The author prefers the voltage-fed PWM inverter to the current-fed PWM inverter because the voltage-fed PWM inverter is higher in efficiency and lower in initial costs than the current-fed PWM inverter [26]. In fact, almost all active filters, which have been put into practical applications, have adopted the voltage-fed PWM inverter as the power circuit.

D. Classification from Control Strategy

Control strategy of the active filters which decides the command of compensating current or voltage produces a great effect not only on the compensation objective and required kVA rating of the active filters, but also on the filtering characteristics in transient state as well as in steady state [10].

D.1 Frequency-domain and time-domain

There are mainly two kinds of control strategies for extracting current or voltage harmonics from the corresponding distorted current or voltage; one is based on the Fourier analysis in the frequency-domain [17][21] and another is based on the instantaneous active and reactive power theory, or the so-called "p-q theory" in the time-domain [8][9]. The control strategy based on or branching from the p-q theory has been applied to almost all the active filters installed by individual high-power consumers over the last five years in Japan.

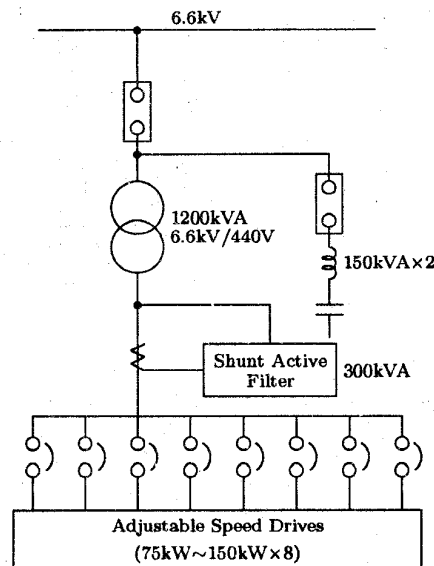

Fig. 7. Application to harmonic compensation

D.2 Harmonic detection methods

Three kinds of harmonic detection methods in the time-domain have been proposed for shunt active filters:

$$\begin{aligned} \text{load current detection:} & \quad i_{AF} = i_{Lh} \\ \text{supply current detection:} & \quad i_{AF} = K_I \cdot i_{Sh} \\ \text{voltage detection:} & \quad i_{AF} = K_V \cdot v_h. \end{aligned}$$

The load current detection and the supply current detection are suitable for the shunt active filters installed in the vicinity of one or more harmonic-producing loads by the individual high-power consumers. On the other hand, the voltage detection is suitable for shunt active filters which will be dispersively installed throughout distribution systems by electric utility companies and for those used in unified power quality conditioners[39][40].

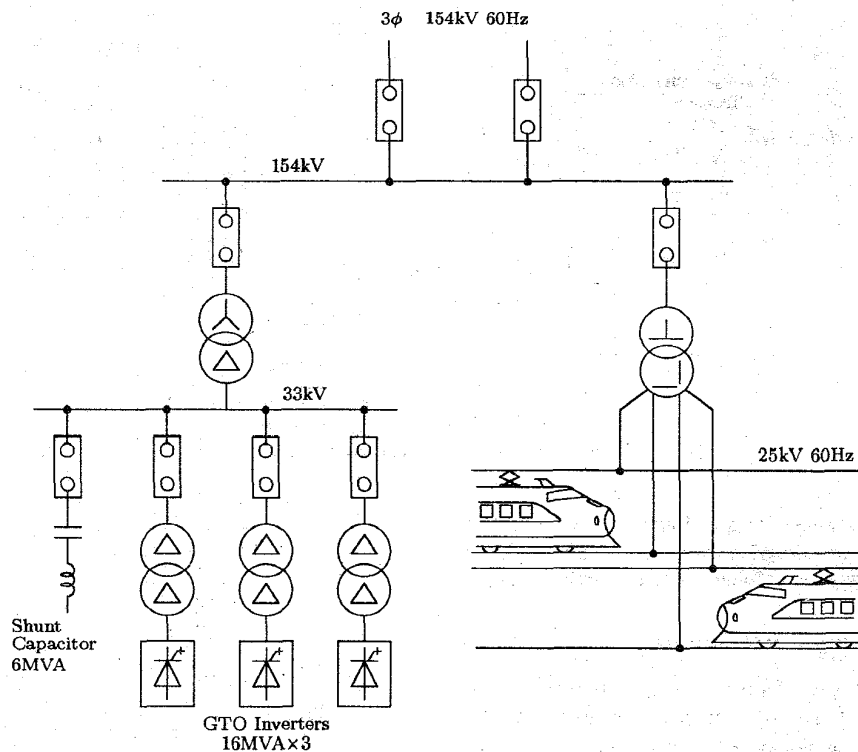

Fig. 9. Application to voltage regulation

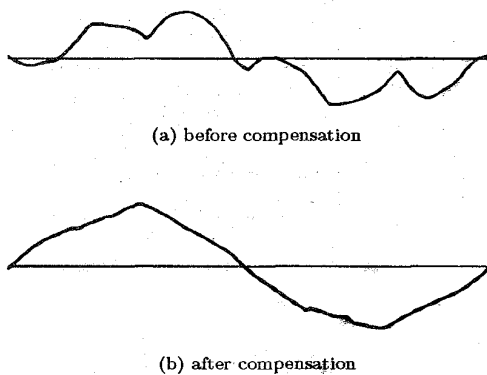

Fig. 8. Supply current drawn from 6.6kV bus

IV. PRESENT STATES OF ACTIVE FILTERS

Since 1981, more than three hundred shunt active filters have been put into practical applications mainly for harmonic compensation with or without reactive power compensation. There is becoming a good market for shunt active filters as the price is gradually decreasing. In fact, the number of practically installed shunt active filters is increasing year by year in Japan. Table 6 shows ratings and application examples of shunt active filters with the first

category of compensation objectives. At present, voltage-fed PWM inverters using IGBTs' modules have been employed as the power circuits, the rating of which ranges from 50kVA to 1000kVA, although PWM inverters using BJTs or GTO thyristors had been employed before.

A. Harmonic compensation

Fig.7 shows a one-line diagram of office building facilities in which a shunt active filter of 300kVA, manufactured by Meidensha Corporation, has been installed to compensate for harmonic currents generated by eight adjustable speed drives. Fig.8 shows two waveforms of the supply current drawn from 6.6kV bus before and after compensation, and their current distortion factor is 38.4% and 7.4% respectively. The most dominant harmonic component contained in Fig.8 is the 5th harmonic current, which is reduced from 33.4% to 5.3%. Voltage distortion factor at 6.6kV bus is reduced from 2.5% to 1.1%, while that at 440V bus is from 7.3% to 2.7%. As another example, a shunt active filter of 440V 200kVA and a shunt active filter of 210V 75kVA, designed and developed by Toyo Electric Manufacturing Company, have been installed for harmonic compensation at water supply facilities in Takatsuki-city, Japan. The shunt active filters have exhibited excellent filtering characteristics which would not be achieved by conventional shunt passive filters, although the active filters are more expensive than the passive filters still now.

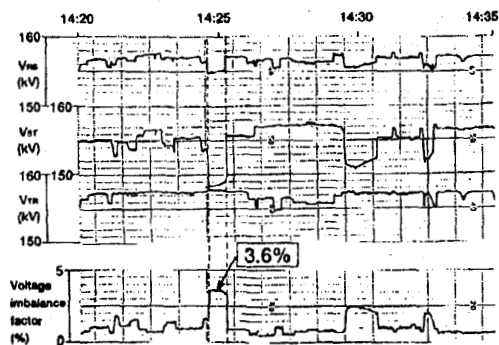

(a) before compensation

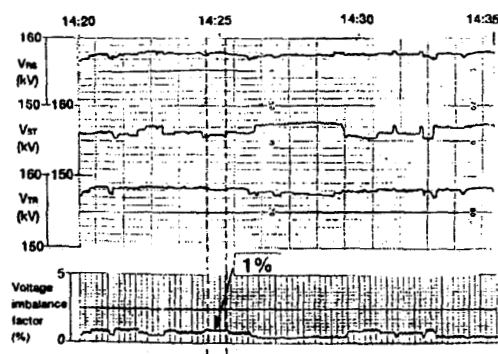

(b) after compensation

Fig. 10. Compensation for voltage drop and imbalance

B. Voltage regulation of impact drop and variation

Three shunt active filters using GTO thyristors-based inverters, each of which is rated at 16MVA, have been installed at Shintakatsuki substation in the Tokaido Sinkansen by Central Japan railway Company, as shown in Fig.9 [34]. The purpose of the large capacity shunt active filter manufactured by Toshiba Corporation is to compensate for impact drop and variation of voltage at the terminals of a power system of 154kV. The impact drop and variation of voltage, which may produce a bad effect on other consumers connected to the same power system, is caused by a large amount of negative-sequence current and a variation of reactive power which result from unbalanced train loads connected to the Scott-transformer. Fig.10 shows voltage waveforms at 154kV bus and voltage imbalance factor before and after compensation. This was actually measured at 14:20-14:30 on July 27, 1994. The shunt active filter has the capability of compensating for the impact drop and variation of voltage and reducing the voltage imbalance factor from 3.6% to 1%.

V. SHUNT ACTIVE FILTERS INSTALLED BY ELECTRIC POWER COMPANIES OR UTILITIES

One of new trends in active filters is that the unified power quality conditioner shown in Fig.6 will be concentratedly installed on primary distribution substains. Another is that shunt active filters for damping of harmonic propagation or resonance will be dispersively installed throughout on feeders in distribution systems. These shunt active filters will be installed by electric utility companies in near future as voltage distortion and harmonics in distribution systems tend to approach or exceed their allowable levels, as shown in Tables 2 and 3.

Fig.11 shows a radial distribution system in a residential area. The rated bus voltage is 6.6kV(line-to-line), and the rated frequency is 50Hz. The equivalent inductive reactance upstream of bus 2, including the leakage reactance of a primary distribution transformer of 15MVA, is to be estimated from the short circuit capacity of 110MVA. The transformer supplies four distribution feeders consisting of feeders 1~4. For the sake of simplicity, only feeder 2 is considered under the assumption that feeders 1, 3 and 4 are disconnected from the transformer. Overhead distribution lines, which are classified into a primary line and branch lines in feeder 2, are assumed to be LR circuits because it is reasonable to neglect the effect of stray capacitors of the distribution lines on the 5th and 7th harmonic voltage and current. Feeder 2 services electric power to eleven medium-voltage consumers of 200~240kW, which install shunt capacitors without any reactor, and to six low-voltage consumers of 50~130kW, which have no shunt capacitor. The total capacity of the loads is 2.99MW, and that of the shunt capacitors for power factor improvement is 0.99Mvar. Harmonic propagation occurs in feeder 2, around the 7th harmonic frequency (350Hz); the 7th harmonic voltage is amplified by four times at the rated load of 2.99MW and by eight times at no load. This results from series and/or parallel resonance between inductive reactances of the distribution lines, along with the equivalent inductive reactance upstream of bus 2, and capacitive reactances of the shunt capacitors on feeder 2.

Each of the following items is the most basic concept of the control strategy and site selection of a shunt active filter which is intended to be installed on the primary line of feeder 2 in Fig.11.

- Voltage detection in the time-domain is stable irrespective of installation point.
- The shunt active filter adopting the voltage detection, which is installed in the vicinity of a harmonic-producing load, is effective in the mitigation of voltage harmonics at the point of installation.
- The shunt active filter adopting the voltage detection, which aims at damping harmonic propagation throughout feeder 2, should be installed at the end of the primary line of feeder 2, that is, bus 9. Harmonic mitigation is a welcome "by-product" of the shunt active filter, which comes from damping of harmonic propagation [40].

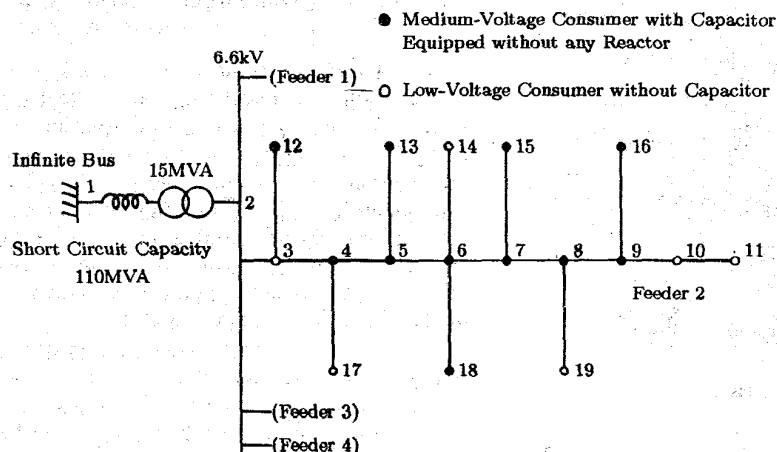

Fig. 11. Radial distribution system in residential area

VI. CONCLUSIONS

The great endeavor of researchers and engineers in automobile industry, not only to solve "air pollution" but also to clear the Clean Air Act Amendments of 1970, has led to the success in suppressing CO, HC, and NO_x contained in the automobile exhaust by 90% respectively, comparing gasoline-fueled passenger cars in the 1990's with the corresponding same class of cars in the beginning of the 1970's. It is interesting that the development of automobile industry, along with the proliferation of cars, has made a great contribution to "absorbing" the cost-up related to reduction of the injurious components contained in the automobile exhaust emitted by gasoline-fueled vehicles.

The guidelines or regulations for harmonic mitigation would be essential and effective in overcoming "harmonic pollution." Although one pays for the cost of high efficiency, or energy-saving, high performance and reliability, and compactness brought by power electronic technology, no one would pay for the cost to suppress or eliminate the current harmonics generated by power electronic equipment unless the guidelines or regulations are enacted. It is expected that remarkable progress of active filters will be made by the continuous effort of researchers and engineers in power electronics, so that the advanced active filters, which have the function of improving power quality as well as compensating for current and voltage harmonics, will come into market in near future.

VII. ACKNOWLEDGEMENTS

The author would like to thank Mr. Nagataka Seki who is Senior Fellow of Fuchu Works at Toshiba, Mr. Masayuki Terashima who is Senior Manager at Meidensha Corporation, and Mr. Masakazu Kohata who is Chief Researcher at Toyo Electric Mfg. Co. Ltd. for their great contributions.

REFERENCES

- [1] B. M. Bird, J. F. Marsh, and P. R. McLellan, "Harmonic reduction in multiple converters by triple-frequency current injection," *IEE Proceedings*, vol. 116, no. 10, pp. 1730-1734, 1969
- [2] H. Sasaki, and T. Machida, "A new method to eliminate ac harmonic currents by magnetic compensation—Consideration on basic design," *IEEE Trans. Power Appl. Syst.*, vol. 90, no. 5, pp. 2009-2019, 1971
- [3] A. Ametani, "Harmonic reduction in thyristor converters by harmonic current injection," *IEEE Trans. Power Appl. Syst.*, vol. 95, no. 2, pp. 441-449, 1976
- [4] L. Gyugyi, and E. C. Strycula, "Active ac power filters," in *Proceedings of the 1976 IEEE/IAS Annual Meeting*, pp. 529-535, 1976
- [5] N. Mohan, H. A. Peterson, W. F. Long, G. R. Dreifuerst, and J. J. Vithaythil, "Active filters for ac harmonic suppression," in *Proceedings of the 1977 IEEE/PES Winter Meeting*, A77026-8, 1977
- [6] J. Uceda, F. Aldana, and P. Martinez, "Active filters for static power converters," *IEE Proceedings*, vol. 130, pt. B, no. 5, pp. 347-354, 1983
- [7] H. Kawahira, T. Nakamura, S. Nakazawa and M. Nomura, "Active power filters," in *Proceedings of the 1983 International Power Electronics Conference*, Tokyo, Japan, pp. 981-992, 1983
- [8] H. Akagi, Y. Kanazawa, and A. Nabae, "Generalized theory of the instantaneous reactive power in three-phase circuits," in *Proceedings of the 1983 International Power Electronics Conference*, Tokyo, Japan, pp. 1375-1386, 1983
- [9] H. Akagi, Y. Kanazawa, and A. Nabae, "Instantaneous reactive power compensators comprising switching devices without energy storage components," *IEEE Trans. Ind. Appl.*, vol. 20, no. 3, pp. 625-630, 1984
- [10] H. Akagi, A. Nabae, and S. Atoh, "Control strategy of active power filters using multiple voltage-source PWM converters," *IEEE Trans. Ind. Appl.*, vol. 22, no. 3, pp. 460-465, 1986
- [11] M. Takeda, K. Ikeda, and Y. Tominaga, "Harmonic current compensation with active filter," in *Proceedings of the 1987 IEEE/IAS Annual Meeting*, pp. 808-815, 1987
- [12] Y. Tanoue, F. Aoyama, and K. Terashima, "5MVA flicker suppression equipment based on voltage-source PWM inverters using GTO thyristors," *Toshiba Rev.*, vol. 43, no. 4, pp. 339-342, 1988
- [13] C. Wong, N. Mohan, S. E. Wright, and K. N. Mortensen, "Feasibility study of ac- and dc-side active filters for HVDC converter terminals," *IEEE Trans. Power Deliv.*, vol. 4, no. 4, pp. 2067-2075, 1989
- [14] S. Moran, "A line voltage regulator/conditioner for harmonic-sensitive load isolation," in *Proceedings of the 1989 IEEE/IAS Annual Meeting*, pp. 947-951, 1989

- [15] H. Akagi, Y. Tsukamoto, and A. Nabae, "Analysis and design of an active power filter using quad-series voltage-source PWM converters," *IEEE Trans. Ind. Appl.*, vol. 26, no. 1, pp. 93-98, 1990
- [16] F. Z. Peng, H. Akagi, and A. Nabae, "A study of active power filters using quad-series voltage-source PWM converters for harmonic compensation," *IEEE Trans. Power Electronics*, vol. 5, no. 1, pp. 9-15, 1990
- [17] W. M. Grady, M. J. Samotyj, and A. H. Noyola, "Survey of active power line conditioning methodologies," *IEEE Trans. Power Deliv.*, vol. 5, no. 3, pp. 1536-1542, 1990
- [18] F. Z. Peng, H. Akagi, and A. Nabae, "A new approach to harmonic compensation in power systems-A combined system of shunt passive and series active filters," *IEEE Trans. Ind. Appl.*, vol. 26, no. 6, pp. 983-990, 1990
- [19] E. H. Watanabe, "Series active filter for the dc side of HVDC transmission systems," in *Proceedings of the 1990 International Power Electronics Conference*, Tokyo, Japan, pp. 1024-1030, 1990
- [20] H. Fujita, and H. Akagi, "A practical approach to harmonic compensation in power systems-Series connection of passive and active filters," *IEEE Trans. Ind. Appl.*, vol. 27, no. 6, pp. 1020-1025, 1991
- [21] W. M. Grady, M. J. Samotyj, and A. H. Noyola, "The application of network objective functions for actively minimizing the impact of voltage harmonics in power systems," *IEEE Trans. Power Deliv.*, vol. 7, no. 3, pp. 1379-1386, 1992
- [22] L. Gyugyi, "A unified power flow control concept for flexible ac transmission systems," *IEE Proceedings*, vol. 139, pt. C, no. 4, pp. 323-331, 1992
- [23] F. Z. Peng, M. Kohata, and H. Akagi, "Compensation characteristics of shunt and series active filters," in *Proceedings of the 1992 Chinese-Japanese Power Electronics Conference*, Beijing, China, pp. 381-387, 1992
- [24] F. Z. Peng, H. Akagi, and A. Nabae, "Compensation characteristics of the combined system of shunt passive and series active filters," *IEEE Trans. Ind. Appl.*, vol. 29, no. 1, pp. 144-152, 1993
- [25] W. Zhang, G. Asplund, A. Åberg, U. Jonsson, and O. Löf, "Active dc filter for HVDC system-A test installation in the Konti-Skan at Lindome converter station," *IEEE Trans. Power Deliv.*, vol. 8, no. 3, pp. 1599-1605, 1993
- [26] H. Akagi, "Trends in active power line conditioners," *IEEE Trans. Power Electronics*, vol. 9, no. 3, pp. 263-268, 1994
- [27] T.-N. Lê, M. Pereira, K. Renz, and G. Vaupel, "Active damping of resonances in power systems," *IEEE Trans. Power Deliv.*, vol. 9, no. 2, pp. 1001-1008, 1994
- [28] N. Tokuda, Y. Ogihara, M. Oshima, and T. Miyata, "Active filter with series L-C circuit," in *Proceedings of the 1994 IEEE/PES International Conference on Harmonics in Power Systems*, pp. 242-249, 1994
- [29] N. Balbo, R. Penzo, D. Sella, L. Malesani, P. Mattavelli, and A. Zuccato, "Simplified hybrid active filters for harmonic compensation in low voltage industrial applications," in *Proceedings of the 1994 IEEE/PES International Conference on Harmonics in Power Systems*, pp. 263-269, 1994
- [30] J. O. Krahn, and J. Holtz, "Total compensation of line-side switching harmonics in converter-fed ac locomotives," in *Proceedings of the 1994 IEEE/IAS Annual Meeting*, pp. 913-920, 1994
- [31] E. Ooba, "Present states of voltage distortion and harmonic interference in power systems," *OHM*, pp. 31-36, 1994 (in Japanese)
- [32] J. Häfner, M. Aredes, and K. Heumann, "A combined system of a passive filter and a shunt active power filter to reduce line current harmonics," in *Proceedings of the 1995 International Power Electronics Conference*, Yokohama, Japan, pp. 388-393, 1995
- [33] M. Takeda, S. Murakami, et al., "Development of an SVG series for voltage control over three-phase unbalance caused by railway load," in *Proceedings of the 1995 International Power Electronics Conference*, Yokohama, Japan, pp. 603-608, 1995
- [34] A. Iizuka, M. Kishida, et al., "Self-Commutated Static Var Generators at Shintakatsuki Substation," in *Proceedings of the 1995 International Power Electronics Conference*, Yokohama, Japan, pp. 609-614, 1995
- [35] W. Ofosu-Amaah, S. Tanaka, K. Miura, and S. Tadakuma, "A dc active filter for traction systems," in *Proceedings of the 1995 International Power Electronics Conference*, Yokohama, Japan, pp. 1639-1644, 1995
- [36] A. van Zyl, J. H. R. Enslin, W. H. Steyn, and R. Spée, "A new unified approach to power quality management," in *Proceedings of the 1995 IEEE/PES Power Electronics Specialist Conference*, pp. 183-188, 1995
- [37] S. Bhattacharya, and D. Divan, "Design and implementation of a hybrid series active filter system," in *Proceedings of the 1995 IEEE/PES Power Electronics Specialist Conference*, pp. 189-195, 1995
- [38] F. Kamran, and T. G. Habetler, "Combined deadbeat control of a series-parallel converter combination used as a universal power filter," in *Proceedings of the 1995 IEEE/PES Power Electronics Specialist Conference*, pp. 196-201, 1995
- [39] H. Akagi, and H. Fujita, "A new power line conditioner for harmonic compensation in power systems," *IEEE Trans. Power Deliv.*, vol. 10, no. 3, pp. 1570-1575, 1995
- [40] H. Akagi, "Control strategy and site selection of a shunt active filter for damping of harmonic propagation in power distribution systems," to be presented at the *1996 IEEE/PES Winter Meeting*, Jan. 21-25, 1996



Hirofumi Akagi (M'87, SM'94) was born in Okayama-city, Japan, on August 19, 1951. He received the B.S. degree from Nagoya Institute of Technology in 1974 and the M.S. and Ph.D. degrees from Tokyo Institute of Technology in 1976 and 1979, respectively, all in electrical engineering. In 1979, he joined Nagaoka University of Technology as assistant and then associate professor in the department of electrical engineering. In 1987, he was visiting scientist at the Massachusetts Institute of Technology

for ten months.

Since 1991, he has been professor in the department of electrical engineering at Okayama University. His research interests are utility applications of power electronics such as active filters and FACTS equipment, ac motor drives, and high frequency inverters and their applications. He has received five IEEE/IAS Society and Committee Prize Paper Awards including the First Prize Paper Award in the IEEE Transactions on Industry Applications for 1991.