

# Next Generation Rover for Lunar Exploration

Dan A. Harrison  
Robert Ambrose  
Bill Bluethmann  
Lucien Junkin

NASA Johnson Space Center  
2101 NASA Parkway  
Houston, Texas 77058  
281-483-8315  
Daniel.a.harrison@nasa.gov

## TABLE OF CONTENTS

1. INTRODUCTION .....	1
2. CHARIOT CONCEPTUALIZATION .....	2
3. DESIGN IMPLEMENTATION .....	4
4. WHEEL MODULE.....	4
5. CHARIOT FRAME.....	5
6. POWERTRAIN CONTROLLER MODULE .....	7
7. POWER DISTRIBUTION UNIT.....	8
8. BATTERY SYSTEM .....	10
9. SYSTEM SOFTWARE .....	10
10. CREW ACCOMMODATIONS .....	11
11. SUMMARY .....	12
REFERENCES .....	12
BIOGRAPHY .....	12

## 1. INTRODUCTION

A bright light appears in the starry blackness above the stark lunar landscape as a cargo lander fires its rockets for descent to the surface. Waiting in the semi-twilight of the lunar south pole, a transport vehicle stands ready to assist the offloading and deployment of the much-needed power system and science laboratory. Meanwhile, another vehicle with a regolith moving blade attached, has just completed the excavation of the new home for the power system on the rim of Shackleton crater. As the Lander touches down several hundred meters away, the first vehicle turns and begins rolling toward it...

As NASA further refines its plans for the return of humans to the lunar surface, it is becoming very clear that surface mobility will be critical to outpost buildup and exploration activities. In analyzing lunar surface scenarios, NASA's Lunar Architecture Team (LAT) identified vehicle chassis potentially suited for lunar surface operations during their Phase I study. These chassis range from small (100 kg) crew aids to very large carriers capable of moving an entire lander. To better understand the technologies and operations for this range of vehicles, NASA's Exploration Technology Development Program is investing in a broad range of surface mobility projects.<sup>1 2</sup>

Within this range of surface mobility assets falls a rover that is capable of moving suited crew members and cargo. A team at NASA's Johnson Space Center in Houston, Texas has developed a prototype of a lunar truck, known as Chariot shown in Figure 4. The Chariot is a new multipurpose, reconfigurable, modular lunar surface vehicle. The basic vehicle consists of a "mobility base"; that is, a chassis, wheel modules, electronics, and batteries. It is capable of multiple modes of operation, human direct control from onboard, teleoperated with small time delays from a habitation module or lander, and supervised under longer time delays from Earth. With the right attachments and/or crew accommodations, the Chariot configuration will be capable of serving a large number of functions on the lunar surface. Functions will include serving as a cargo carrier, regolith mover, human transportation, and a cable layer. This lunar truck is named Chariot because of the chariot-like "look" of the standing crew members driving the vehicle.

### *Lessons from Apollo*

"Dust is the number one concern in returning to the moon"  
-Apollo 16 Astronaut John Young, July 2004

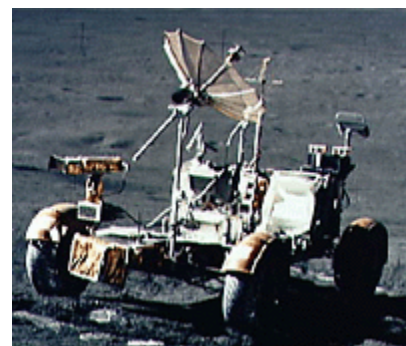

**Figure 1 – Lunar Roving Vehicle**

The Apollo missions 15, 16, and 17 made use of the Apollo Lunar Roving Vehicle (LRV), shown in Figure 1 above, to provide extended surface mobility in excess of the short walks on earlier missions. The LRVs were designed primarily as crew transport vehicles with a limited amount of science payload (moon rocks) capability. Several lessons

<sup>1</sup> "U.S. Government work not protected by U.S. copyright."

<sup>2</sup> IEEEAC paper #1196, Final, December 5, 2007

were learned from the LRV operations on the moon. First, ground speed could not exceed 10 mph in most situations. The 1/6 G environment allowed the vehicle to lose contact with the surface when moderate bumps were encountered at approximately 9 mph, resulting in a momentary loss of control. Second, the lunar dust behaved much like wet sand on Earth and tended to stick to the surface (Figures 2 and 3). Moon dust is extremely abrasive and dust mitigation measures must be taken to prevent excessive wear at any place where dust can enter. The dust also has an adverse effect on the properties of heat radiators. Within a very short period of time, dust would cover the LRV radiators and the efficiency would drop precipitously.



**Figure 2. Dust-free.**



**Figure 3. Dust-covered after driving.**

Figures 2 and 3 are photos from “The Effects of Lunar Dust on Advanced Extravehicular Activity Systems: Lessons from Apollo”, James R. Gaier, NASA Glenn Research Center, Ronald Creel, Science Applications International Corporation.

Additionally, the Apollo astronauts noted that with the open frame design, it felt as though a person could fall out of the vehicle while traversing a steep slope. A review of Apollo Lunar Rover operations indicated room for improvement in ride, suit interfaces, and reliability. Apollo mission reports indicate the vehicle performed well during operations, but driving on cross slopes was described as feeling “very uncomfortable” by the operators. Suit interfaces for the Apollo LRV posed challenges for astronauts attempting to sit in the LRV seat. The chief problem was the rigidity of the suit torso and the difficulty in bending at the waist, as required for sitting. Lastly, rovers designed for the return to the lunar surface will be required to have a much greater lifespan, a longer range, and be rechargeable.

## 2. CHARIOT CONCEPTUALIZATION

From the very beginning, it was decided to challenge conventional thinking about what a lunar rover should look like and how it should drive. Why is a side-by-side seating arrangement the best for suited crew? Would an inline arrangement be better? How about four crew rather than two? With more crew members on the surface, using multiple rovers, a four-crew capability could allow the rover to serve as a rescue vehicle. The wheel arrangement and number of wheels was also challenged. Aware that this vehicle will be serving as a truck, crew hauler, regolith mover and more, four wheels may not be enough. With only 1/6 G and rugged terrain a six-wheeled rover would be better suited, similar to the rovers the NASA Jet Propulsion Laboratory landed on Mars. Not only do six wheels provide more traction on uneven surfaces, redundancy would be an added bonus.



**Figure 4. Lunar truck concept.**

Additionally, based on lessons learned from the LRV, it would be better for a suited crew member to have the rover’s body closer to the ground to make stepping up onto the vehicle easier. But that reduces ground clearance and would be unacceptable. The solution is a combination of passive/active suspension which is capable of lowering the vehicle for easy mounting by the crew, then rising to a height which provides optimum clearance but would otherwise be undesirable for crew accessibility. An active suspension provides the ability to dynamically level the body when traversing a slope, avoiding the feeling that one is about to fall out the vehicle, that the Apollo crew noted. Redundancy in wheel modules is enhanced through active suspension. If the steering, brake, or drive of a wheel module fails, that wheel can be lifted off the surface and the vehicle goes home on five wheels. This is not possible with a four-wheeled configuration.

Last, much thought was given as to how the vehicle should be steered. The concept which won out was “crab steering.” Crab steering means each of the six wheels can rotate 360 degrees, giving the vehicle the ability to move in any direction or rotate at any point. This makes maneuvering in tight places possible where a conventionally steered vehicle could not operate. This would be a more mechanically complex challenge. Whereas, the LRV had a motor on each wheel hub, a crab steering design requires that the motors be

located away from the wheels, and that the wheel be driven by a driveshaft for full 360 degree rotation. Here, the huge gain in flexibility is deemed of greater value than the added complexity of crab steering.

#### *Chariot Requirements/Specifications*

The LAT, Phase I, defined a lunar surface vehicle designated as “Chassis B” that would serve as a primary mobility base, meant for use in systems such as unpressurized rovers and in-situ resource utilization (ISRU) transport, with a planned life of 5 years. The vehicle was not sized for use in permanently shadowed crater areas.

The vehicle should have multiple control modes, human direct onboard driving, be teleoperated from a habitat module and teleoperation from Earth. The power systems should be sized to provide extended mobility and limited power to payloads. It should have navigation sensors and basic communications infrastructure with up to 2Mb/sec transfer rates to locations on the moon or directly to Earth, and should also be capable of autonomously recharging the batteries.

Based on the LAT Chassis B vehicle, the Chariot, shown in Figure 4, has the following specifications:

#### *Chariot Design Specifications*

The JSC design team accepted the requirements from LAT Phase I and developed an overview of the project which would include major milestones as well as the following detailed specifications for a lunar surface vehicle.

- **Project Overview**
  - Develop new chassis for unpressurized and pressurized rovers
  - Improved suspension
  - Faster
  - More durable
  - More maneuverability
  - Longer range surface vehicles
  - Capable of being controlled remotely
- **External Milestones**
  - 04/2007: Chassis design complete
  - 08/2007: Chassis ready for testing
- **Suspension**
  - Adaptive Suspension
  - 25” vertical active travel, full stroke in 9 seconds
  - 11” passive travel
  - 1000 kg payload capacity (crew and cargo)
  - Able to put its frame or “belly” on the surface
  - Lift wheels off ground
  - Capable of climbing steps
- **Steering**
  - All-wheel independent steering
- Continuous rotation
- 380 ft-lb
- 145 deg/s
- **Drive**
  - Six dual wheels
  - 20 km/hr top speed
  - Two-speed transmission
  - 20 HP (full vehicle)
  - 4000 ft-lb max torque (full vehicle)
  - Open differential, with drop in limited slip differential
  - Capable of climbing 15 degrees (slope in 1g)
  - Two wheels per module
  - Neutral and brake
- **Wheels**
  - Modular hub
  - Fenders
  - Pneumatic options
  - Custom non-pneumatic options
- **Frame**
  - Tubular frame (Baja style)
  - Houses batteries
  - Reconfigurable for 0, 2 or 4 crew/cargo
  - Data and power ports for tools
- **Crew Accommodations**
  - Two crew nominal
  - Four crew contingency
    - Upright drive configuration
    - Primary crew in-line
    - Capable of suited crew or shirt sleeves driving
    - Crew interface is derivative of the crew and thermal systems division donning stand
    - Turrets
    - Adjustable for crew heights
    - Modular dashboard design
- **Power**
  - 25 km range
  - 4 hours run-time
  - 300VDC power bus
  - Lithium-ion batteries
  - Custom battery management system
  - Power distribution
  - E-stop
- **Electronic Control and Communication**
  - Embedded Powertrain Control Modules
  - Custom motor drivers
  - Controller Area Network (CAN) bus
  - Quick start up (targeting 15 seconds)
  - Compact PCI chassis
  - Ethernet for off-board control and autonomy

### 3. DESIGN IMPLEMENTATION

This project had a short 11-month development schedule, so it was necessary to reduce risk to the maximum extent possible. It was decided to build early ‘Generation 1’ (Gen1) products for the higher risk elements, namely the transmission, suspension, and steering systems. The Gen1 testbed was constructed by February 2007 and both the transmission and steering designs were modified as a result of testing. The team then proceeded to design the final vehicle using the specifications shown earlier as the design requirements.

### 4. WHEEL MODULE

The Chariot has six wheel modules that are independent and alike. Each wheel module consists of suspension, drive, and steering systems. The complete wheel module is shown in Figure 5 below.



Figure 5. Wheel module with suspension.

#### *Suspension*

The suspension system allows Chariot a smooth ride as well as the ability to put the bottom of its frame, also known as the “belly” on the ground, “level” the vehicle, and lift wheels independently. The ability for Chariot to put its “belly” on the ground is beneficial for various reasons: eases the astronauts’ effort to get on and off the lunar truck; reduces ground pressure by orders of magnitude when Chariot is stationary; and reduces maintenance efforts in many situations. The ability to “level” the vehicle has many benefits: allows leveling of Chariot on uneven terrains; lets the truck “lean” into a slope; and provides for tools to be positioned at desired angles and heights. The ability of Chariot to lift wheels independently also has benefits, especially with the six-wheel design: allows Chariot to adjust the ground pressure at each wheel; increases the probability of getting out of a “sticky” situation; provides an easy “work-around” of lifting a wheel off the ground if a wheel module fails; and reduces the maintenance effort in many instances.

Chariot’s suspension is a load-sensing, dual-arm configuration with inboard active and passive elements. As

seen in Figure 6, the custom-designed arms take full advantage of Chariot’s ability to adjust the wheel height as well as locate most suspension elements inside the vehicle for protection. The active and passive elements are in series and control the upper arm. The active element allows the wheel module to be independently raised or lowered with a range of over 20 inches. This is accomplished by adjusting the lower pivot point of the passive suspension using a linear actuator and guide rails. The active suspension is a low-frequency system that can travel through its full range of motion in less than 10 seconds. The passive element is a dual coil-over-shock configuration used in many off-road vehicles. With this more traditional design, many options are available for Chariot to stiffen or soften the ride as well as vary the suspension’s mid-range for various payloads.

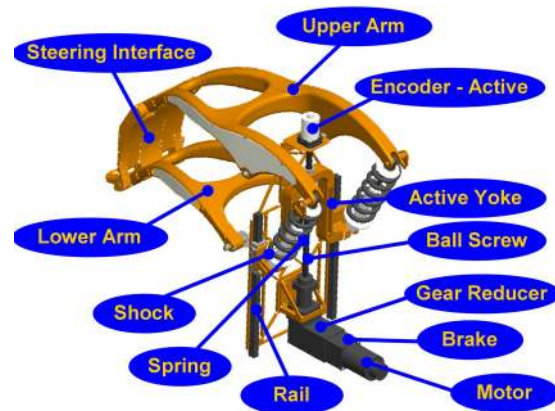

Figure 6. Suspension system.

#### *Drive System*

The drive system provides Chariot the ability to bulldoze as well as travel around at over 15 miles per hour. The drive consists of two drive motors, a two-speed transmission, brake, a drive shaft, differential, and dual wheels. Two standard direct current (DC) brushless motors that can produce three horsepower drive each wheel module, resulting in a vehicle rating of more than 30 horsepower. The transmission, a custom two-speed design, incorporates two electromagnetic clutches that determines the engaged gear set thus providing the desired gear: low, high, or neutral. Low gear provides a pulling and pushing force of over 800 lbs for each wheel module and over 4000 lbs for Chariot. This allows Chariot to do civil engineering tasks such as dozing, trenching, leveling, and berming, as well as traversing steep grades. In low gear, the Chariot has a top speed of approximately three mph. High gear provides Chariot the ability to travel over 15 mph. Rotation sensors positioned on the transmission’s input and output shafts allow for synchronized shifting as well as determining and controlling Chariot’s speed. Although the motors are used for braking during normal operations, an electromagnetic brake is positioned on the output shaft for parking Chariot and to stop Chariot in case of an anomaly. The drive shaft, coaxial with the steering axis, transmits power from the transmission to the differential. The differential contains a commercially available automotive “open differential” gear



set and has a custom housing that incorporates double-row tapered roller bearings to provide support for the output shafts. The common gear set allows for Chariot to have a wide variety of torque multiplying or limited slip options. The differential allows for the dual wheels to differentiate during normal driving as well as during steering. The wheels are commercially available 27-inch-diameter off-road wheels that can provide up to 40 psi of ground pressure.

### Steering System

The steering system, displayed in Figure 7, provides Chariot infinite steering with ample torque, speed, and redundancy. The steering consists of two motors, two gear trains, two absolute rotation sensors, and a housing that positions the steering components along with connecting the drive and suspension systems. The two motors provide Chariot with over 300 ft-lbs of torque at a rate of more than 90 degrees per second. The gear trains incorporate harmonic drives and are very similar to those used in Robonaut (<http://robonaut.jsc.nasa.gov/>). Since a reliable steering system is important to nominal operations, the motors, gear trains, and sensors are entirely independent; if any motor, drive, or sensor fails, Chariot continues to have the power and sensing needed to steer the wheel module. Structurally, the steering hub is hollow to allow the drive shaft to pass freely and rotate using opposing tapered roller bearings. With infinite steering, Chariot can efficiently and quickly change steering angles while avoiding any wind-up constraints.

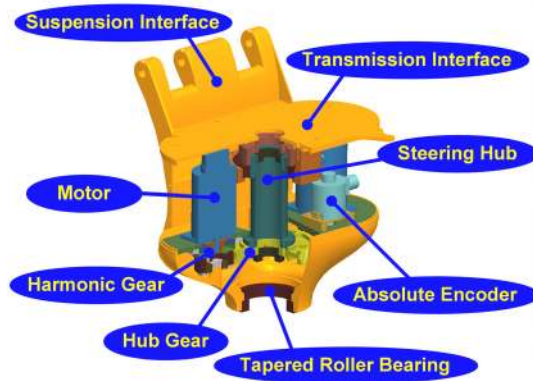

Figure 7. Steering system.

## 5. CHARIOT FRAME

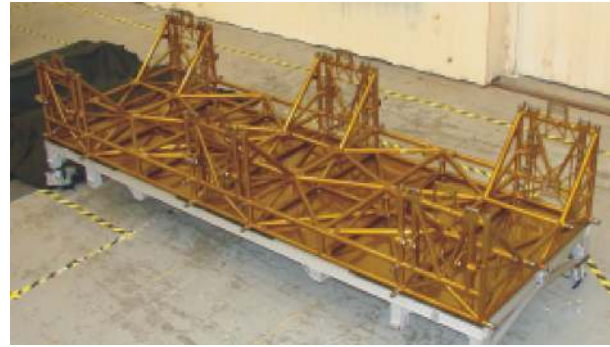
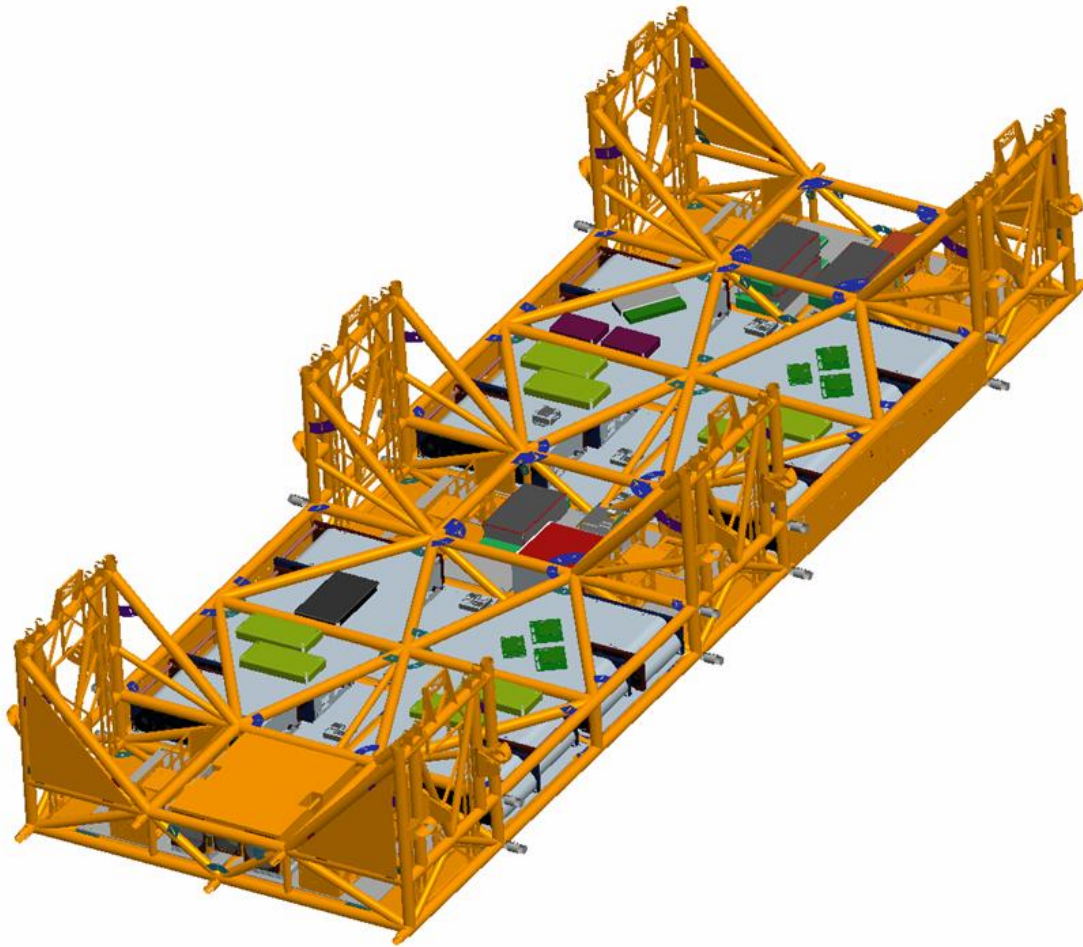

Figure 8. Bare frame as received from supplier.

The frame, shown in Figure 8, provides Chariot a solid foundation from which to integrate wheel modules, batteries, electronics, sensors, tools, modules, and a work platform. The frame is a chrome moly “space frame” often used in automobile prototypes, road racing, and off-road racing. NASA teamed with a leader in Baja racing frames to design and create Chariot’s frame. Within the frame is housed the lithium-ion batteries, the power distribution unit, the motor controllers, the central processing unit, the communications hardware, and an independent safety system as shown in the Figure 9 concept model. Packaging these components inside the frame not only protects these components, it also allows for a very “clean” deck for payloads and crew. The frame supports the wheel modules at the suspension arm pivot points along with the active suspension rails and linear actuator. The frame also has an array of receivers that can accommodate components, tools, and modules on the front, rear, sides, and top of Chariot. Some examples of devices that will use these receivers are crew contingency accommodations, blade, bucket, excavator, drill, dump bed, autonomy sensors, and a habitat. The frame design also went through a Gen1 design phase before manufacturing the final frame. The Gen1 frame was constructed of .080 thick tubing, this proved to be excessively heavy so the frame was redesigned with mostly .040 wall tubing with a few extra support members added for stress margin. This saved over 100kg of vehicle mass from the Gen1 design.



**Figure 9. CAD model of frame with batteries and electronics.**

## 6. POWERTRAIN CONTROLLER MODULE

The Powertrain Controller Module (PCM) is a five-axis Servo Motor control unit. Contained within are five motor drivers, designed to drive brushless servomotors. These drives operate in torque, velocity, or position mode. All drives use CANOpen for drive configuration and control. CANOpen is an open protocol for distributed automation and motion control. The PCM also contains a specialized interface board, communicating on the CAN bus, which controls the brakes, gear selection, and reads the high-resolution encoders. The PCM accepts five 340VDC motor power inputs: one for each driver. A 24VDC input is used for driver logic while a single 28VDC input is used for brakes and clutches (Figures 10 and 11).

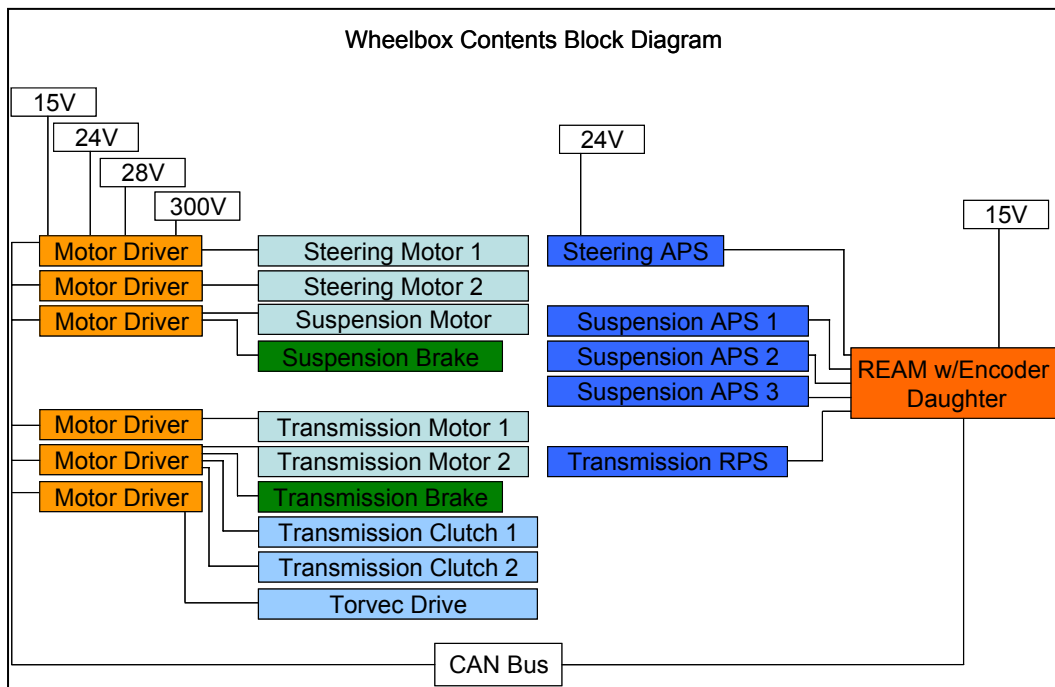

Figure 10. Wheelbox contents block diagram.



Figure 11. Powertrain control module – installed with plexiglass cover.

## 7. POWER DISTRIBUTION UNIT

The Power Distribution Unit (PDU), illustrated in Figure 12, provides a means to control and distribute battery power and regulated low-voltage DC power to Chariot subsystems via CAN bus communication. Each bus voltage will be monitored at three levels. The battery bank will be monitored by the Battery Management System (BMS). This system will transmit the individual cell health to the PDU Controllers. The PDU system will take preemptive measures to protect the batteries from dropping below their minimum voltages. The response will include warning the operator of the condition and the need for recharge within a predetermined amount of time, disabling certain nonessential functions, and then finally shutting down the vehicle. An override may be available with acknowledgement that the batteries may be damaged beyond repair.

The output voltage of each converter will be monitored by a power supply sequencer. This device will shut down all converters if the output of the converter falls outside of a preset window. This will act as a last resort safety measure to protect the electronics from catastrophic events. The supply for each sub-assembly will be monitored by the PDU control software. The voltage measurement will be sent to the chassis off chassis processor as part of a health packet. If the voltage is outside of a specified window, the PDU control software will flag it and inform the operator. Each bus current will be monitored at two levels. The output current of each converter will be monitored by PDU control software. The current measurements will be sent to the vehicles off chassis processor as part of a health packet. The off chassis processor can be on the crew accommodation system or at a teleoperator station. The PDU control software will shut down the converter if the output of the converter exceeds a preset value. This will act as a last resort safety measure to protect the electronics from catastrophic events.



# Power Distribution

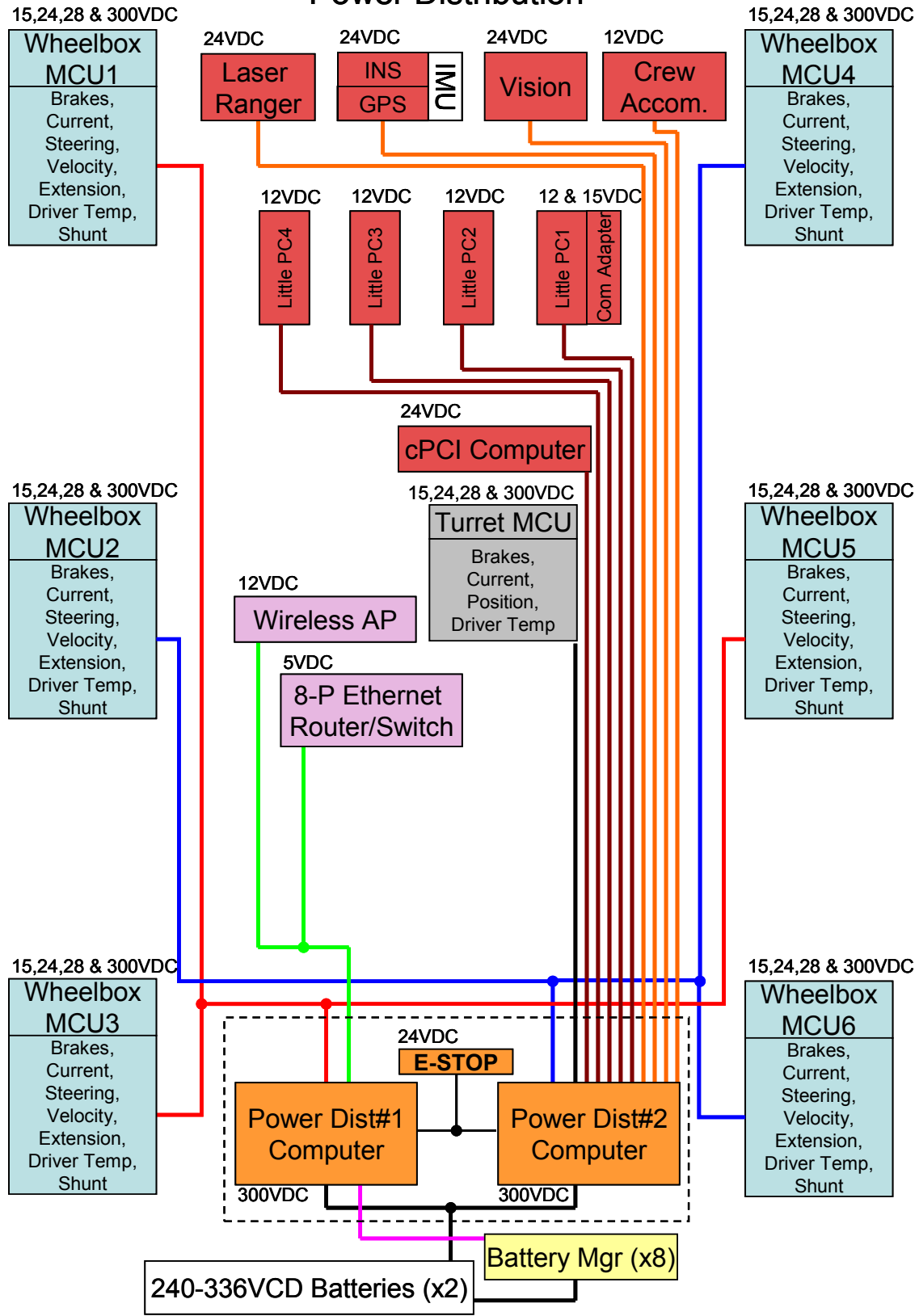

Figure 12. Power distribution unit.

## 8. BATTERY SYSTEM

The Chariot battery system is composed of eight 36VDC lithium-ion battery packs. Each battery pack, as shown in Figure 13, contains 10, 3.6V 60amp hour cells connected in series. The cells are provided by Lithium Technology and are the higher power HE-602050 part. Each battery pack weighs approximately 37 lbs. Since the batteries are connected in series, it's very important that all batteries remain matched in terms of 'state of charge' at all times. The Chariot uses a BMS, also from Lithium Technology, which monitors the voltage of every cell and temperature of each battery pack. The BMS will shut off vehicle power if any cell voltage becomes too low or if the temperature limit is exceeded. The BMS also monitors the battery system during charging operations which can be hazardous if not performed correctly. Overcharging can result in the plating out of lithium metal, which is a very hazardous condition.

The battery system has been sized to allow for a 25 km range over hard ground. The max battery output is 120 amps. With a fully charged battery voltage of 42V per pack, and 336VDC bus voltage, there is slightly over 40kw available for climbing and earthmoving operations.



Figure 13. Battery pack.

## 9. SYSTEM SOFTWARE

For its initial release, the software on the Chariot system is very minimal. At the core of system is an embedded PowerPC running the vxWorks™ operating system in a compact PCI chassis. The only input/output (I/O) to the Chariot is through three CAN devices, running at 1 MBit/s. The CAN devices control the vehicle's left and right side, and power system. The network traffic was split to enable greater throughput to the system. The power distribution system monitors the batteries and controls the power distribution system.

The core of Chariot's software is a module that performs low-level control, sequencing, safety functions and I/O. The low-level sequencing and safety functions serve as a lightweight system manager. These system manager functions are a derivative of Robonauts System Manager.

The vehicle's inverse kinematics solution uses the method of instantaneous centers to point all wheels at the same point in space. The wheels are then driven at the appropriate velocities to drive the vehicle with the desire linear rates and angular rate. Figure 14 is the output of a visualization tool used to test the Chariot's drive kinematics. In the tool, the arrows represent the vehicle's six wheels. The angle of the arrow represents the direction the wheel points. The magnitude of the arrow represents the drive velocity of the wheel.

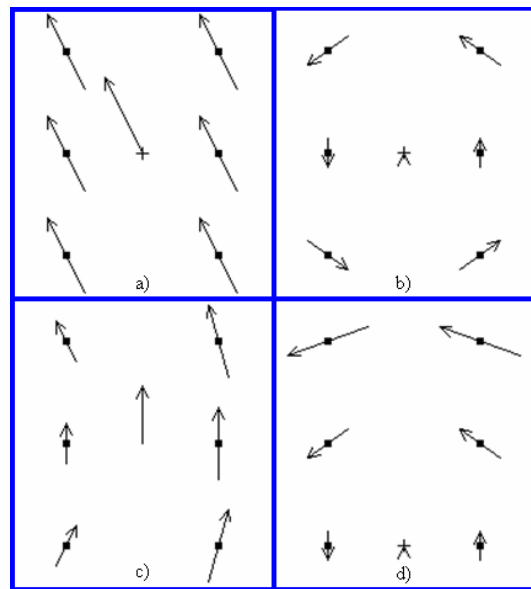

Figure 14. a) driving in a general direction; b) zero turn radius; c) double ackerman driving; d) turning about a general position.

The system is controlled from an off chassis processor through an application programmer's interface (API). This API is a well-defined interface for getting telemetry and status out of the vehicle and issuing mode and driving commands to the vehicle. This API allows the core motion system to treat command consistently whether they are generated by an on-board driver, a teleoperator driving with a small time delay from either line-of-site or from within a habitat, a semi-autonomous waypoint generator, or a Earth-based driver operating the vehicle across time delay.

## 10. CREW ACCOMMODATIONS

Chariot is basically a “lunar surface mobility platform” designed for transporting payloads, regolith moving and excavation, and crew transport.

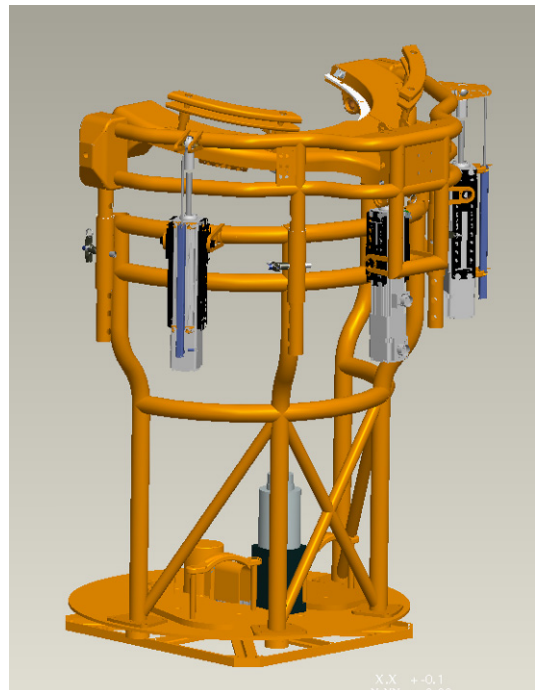

**Figure 15. Console – crew accommodation system.**

In keeping with a modular design, the crew accommodation system is a “bolt on” fixture. Chariot can be configured for one, two, or four crew members, with the four-crew configurations used for emergencies or short distance transport. The Chariot crew accommodation system is designed for both shirtsleeve and suited operations, so test and evaluation can be conducted without the added overhead of bringing suited crew to the vehicle. The crew accommodation system is designed to operate with a Mark III suit, so an adapter needed to be designed for a non-suited (shirtsleeve) crew to operate the vehicle. The shirtsleeve configuration, developed jointly with a custom racing seat company, uses racecar seat technology to fit a driver into the mounting designed for the Mark III. The current version uses fixed sizes for different size crew. Future versions will have adjustable/removable headrest, ear loops, and shoulder wings. The stand has an integrated Mark III Waist Joint Ring, as shown in Figures 15, 16 and 17.



**Figure 16. Shirtsleeve stand with waist joint ring.**

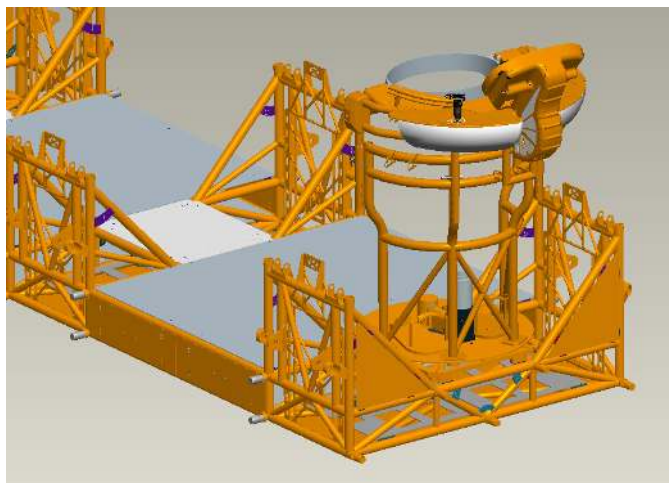

**Figure 17. Donning stand – crew accommodations.**



**Figure 18. Console in driving mode.**

The console display (Figure 18) provides an operator with vehicle and environmental information, and controls. To provide for a quick startup, a default drive mode will be pre-selected and minimal crew interaction with the vehicle will be required. The onboard operator will be able to drive in one of two modes, Ackerman or crab. Crab steering sometimes referred to as “coordinated steering,” is a mode where all wheels are steerable, as opposed to the traditional Ackerman steering, where only the wheels on one axle steer a four-wheeled vehicle.



**Figure 19. Crew accommodation system vehicle interface.**

## 11. SUMMARY

New technologies have been developed to provide improved suspension and steering for pressurized and unpressurized, manned and unmanned rovers, yielding faster, more durable, more maneuverable and longer range surface vehicles. Systems have been designed to facilitate testing with the Advanced Mobility and Manipulation Commanding capabilities. It’s now possible for new missions such as operating ISRU equipment, habitat construction, and moving across large stretches of lunar surface that were not possible with the Apollo Lunar Rovers. Since the 1960s-era development of the Apollo

systems, major advances have occurred in power, computing, actuators, communication, and sensing component technologies, providing the rover Chariot with unprecedented capabilities.

## REFERENCES

- [1] Apollo 16 Astronaut John Young, July 2004.
- [2] Figures 1, 2 and 3 are photos from “The Effects of Lunar Dust on Advanced Extravehicular Activity Systems: Lessons from Apollo”, James R. Gaier, NASA Glenn Research Center, Ronald Creel, Science Applications International Corporation.

## BIOGRAPHY



**Daniel Harrison** is the Branch Manager for the Robotic Systems Technology Branch at NASA’s Johnson Space Center located in Houston, Texas. Since 2007, Dan has led this branch to develop Robotic systems such as the Chariot, Robonaut and other robotic assistants that will be and are capable of working with human teammates. In 1974, Dan obtained a Bachelor of Science in Physics and Mathematics, specializing in electromagnetics and circuits, from the Northeastern Oklahoma State University. Dan started his career with JSC in 1978 as a contractor and 10 years later was hired as a government civil servant. From 2003 to the beginning of 2007, Dan served as the Senior Technical Advisor for electronic systems within the Robotic Systems Branch. Prior to his work in Robotics, Dan worked as Branch Chief of the Electronic Design and Development Branch which is responsible for many Space Shuttle and Space Station flight projects. Being Early Communications (ECOMM) avionics manager, Dan proposed a space rated CTP design which could meet all of the ECOMM requirements, including keeping close to the planned schedule and staying within the planned budget. Dan has been project manager of the Orbiter Interface Unit, designing and delivering on time Critical 1 avionics hardware products. He has also served as section head of the Data Management Systems Hardware Section, managing several employees and starting his civil service career as an electrical engineer in the Flight Projects Branch.





**Dr. Robert O. Ambrose** serves as the Assistant Division Chief of JSC's Automation, Robotics and Simulation Division. His responsibilities

include management of the technology and advanced mission work for the Division, working with NASA programs and other customers to position automation and robotics solutions for future flight needs. He is the manager for the Human-Robotics Systems Project, leading a multi-center team of engineers from JSC, ARC, JPL, KSC, LaRC, GRC and GSFC. He is the Division manager of the advance Robonaut 2 Project, developing the next generation of dexterous robotic systems. He served as the Surface Mobility lead for NASA's Lunar Architecture Team, developing mission concepts, design reference missions, and requirements for lunar surface operations. He continues in this architectural role as the Surface Mobility Element Lead for the Constellation Program's Architecture Team (CxAT) and the Lunar Surface Systems (LSS) Project.



**William Bluethmann** works at the NASA Johnson Space Center where he is the Deputy Branch Chief for the Intelligent Systems Branch within the Automation, Robotics and Simulation Division. He currently leads software integration and testing for the Chariot Rover and has long held the role of software lead for

the Robonaut team. His research interests include manipulator control, force control, distributed autonomy, and task level automation. He earned a PhD. in Mechanical Engineering from the University of Kansas.



**Mr. Lucien Junkin** is currently the lead designer for the Lunar Truck Prototype, Chariot, along with the project manager for NASA's Automated Bulldozer Project. He is also involved with the NASA Robotics Education Project including being the leader of the JSC-Clear Creek Independent School District Robotics Team. He

earned his Bachelor of Science in Mechanical Engineering in 1989 at Mississippi State University. Mr. Junkin has been with Johnson Space Center for seventeen years.

From 2000 to 2007, Mr. Junkin was responsible for the design, manufacturing, and integration of several robotic subsystems including Spidernaut electro-mechanical systems, assembly and integration of Robonaut Unit B joints, and Robonaut's flight-worthy joints. During this period, he was placed on special assignment to oversee the design completion, manufacturing, assembly, and integration of the SCOUT mobility subsystem. Mr. Junkin has also taken an active role in mentoring young engineers, mainly on the Robonaut Team, to advance their technical skills, instill expectations, and develop teamwork along with

evaluating their capabilities for future assignments. For the past ten years, he has taken an active role in NASA as well as Houston's robotics education outreach efforts including being a member of the NASA Robotics Education Project, director of the Lone Star FIRST LEGO League, Houston Engineering And Robotics Learned Young (EARLY), and Texas Botball tournaments along with being a member of the Lone Star For Inspiration and Recognition of Science and Technology (FIRST) tournament committee.

From 1995 to 2000, Mr. Junkin was part of the Lockheed Martin technical team that was responsible for developing, manufacturing, integrating, operating, and maintaining several crew robotics trainers including the Multi-use Remote Manipulator Development Facility (MRMDF) and the Dexterous Manipulator Trainer (DMT). For part of this period, he also led the Lockheed Martin efforts for the Autonomous EVA Remote Camera (AERCam) Integrated Ground Demonstration.

From 1990 to 1995, Mr. Junkin was part of the International Space Station (ISS) design team which included developing and testing robotics standards for the ISS along with feasibility studies such as module assembly with the Space Station Remote Manipulator System (SSRMS) and ground control of robotic systems.