

PROCEEDINGS OF SPIE

[SPIDigitalLibrary.org/conference-proceedings-of-spie](https://spiedigitallibrary.org/conference-proceedings-of-spie)

NFIRAOS adaptive optics for the Thirty Meter Telescope

Jeffrey Crane, Glen Herriot, David Andersen, Jenny Atwood, Peter Byrnes, et al.

Jeffrey Crane, Glen Herriot, David Andersen, Jenny Atwood, Peter Byrnes, Adam Densmore, Jennifer Dunn, Joeleff Fitzsimmons, Tim Hardy, Brian Hoff, Kate Jackson, Dan Kerley, Olivier Lardière, Malcolm Smith, Jonathan Stocks, Jean-Pierre Véran, Corinne Boyer, Lianqi Wang, Gelys Trancho, Melissa Trubey, "NFIRAOS adaptive optics for the Thirty Meter Telescope," Proc. SPIE 10703, Adaptive Optics Systems VI, 107033V (17 July 2018); doi: 10.1117/12.2314341

SPIE.

Event: SPIE Astronomical Telescopes + Instrumentation, 2018, Austin, Texas, United States

NFIRAOS adaptive optics for the Thirty Meter Telescope

Jeffrey Crane^{1*}, Glen Herriot¹, David Andersen¹, Jenny Atwood¹, Peter Byrnes¹, Adam Densmore¹, Jennifer Dunn¹, Joe Jeff Fitzsimmons¹, Tim Hardy¹, Brian Hoff¹, Kate Jackson¹, Dan Kerley¹, Olivier Lardière¹, Malcolm Smith¹, Jonathan Stocks¹, Jean-Pierre Véran¹, Corinne Boyer², Lianqi Wang², Gelys Trancho², Melissa Trubey²

¹ NRC Herzberg Astronomy and Astrophysics Research Center, Victoria BC, Canada

² Thirty Meter Telescope International Observatory, Pasadena, California, USA

ABSTRACT

NFIRAOS (Narrow-Field InfraRed Adaptive Optics System) will be the first-light multi-conjugate adaptive optics system for the Thirty Meter Telescope (TMT). NFIRAOS houses all of its opto-mechanical sub-systems within an optics enclosure cooled to precisely -30°C in order to improve sensitivity in the near-infrared. It supports up to three client science instruments, including the first-light InfraRed Imaging Spectrograph (IRIS). Powering NFIRAOS is a Real Time Controller that will process the signals from six laser wavefront sensors, one natural guide star pyramid WFS, up to three low-order on-instrument WFS and up to four guide windows on the client instrument's science detector in order to correct for atmospheric turbulence, windshake, optical errors and plate-scale distortion. NFIRAOS is currently preparing for its final design review in late June 2018 at NRC Herzberg in Victoria, British Columbia in partnership with Canadian industry and TMT.

Keywords: MCAO, TMT, Thirty Meter Telescope, NFIRAOS, Instrumentation

1. INTRODUCTION

NFIRAOS resides on the Nasmyth platform of TMT. NFIRAOS has several unique design features: its optics are cooled to -30°C , resulting in 2.5x gain in efficiency for spectrographic observations between the OH lines in K band; its dual OAP relay allows both the wavefront error and distortion caused by the relays to be cancelled out; and a focal plane pinhole mask allows astrometric calibrations to be performed internally by NFIRAOS. The optics are mounted on a space frame structure 'optical table' enclosed by an insulated cold room thermal enclosure (8x10x4 meter), and the table and enclosure in turn are surrounded and supported by a steel exoskeleton. This steel frame, the Instrument Support Tower (IST), provides a direct load path to the TMT telescope Nasmyth platform for NFIRAOS and its three client instruments, which together have a total mass of 70 tonnes (49.5 tonnes for NFIRAOS and 6.8 tonnes for each client instrument).

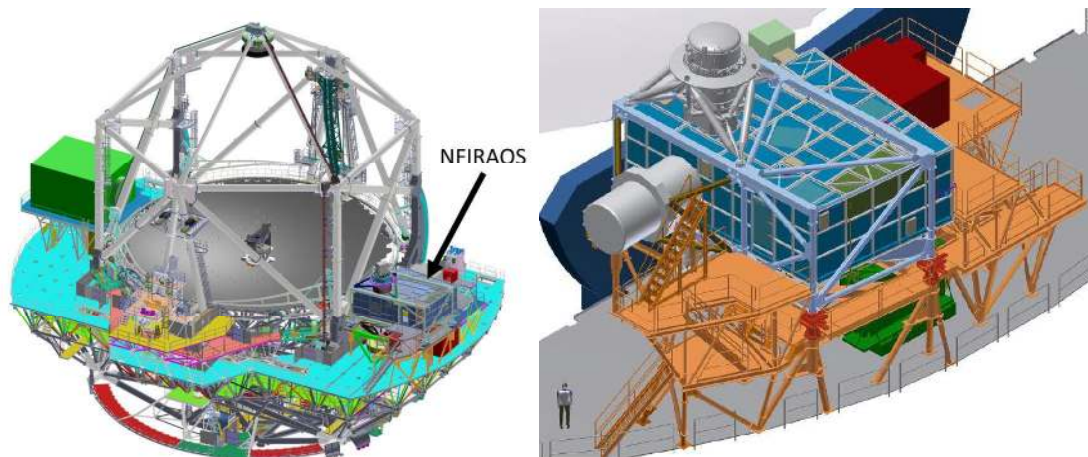

Figure 1 Left: TMT & NFIRAOS; Right: NFIRAOS on TMT Nasmyth platform with client instruments visible on top and side

*Jeffrey.crane@nrc-cnrc.gc.ca; phone +1-250-363-0054; www.nrc-cnrc.gc.ca

Adaptive Optics Systems VI, edited by Laird M. Close, Laura Schreiber,
Dirk Schmidt, Proc. of SPIE Vol. 10703, 107033V · © 2018 SPIE
CCC code: 0277-786X/18/\$18 · doi: 10.1117/12.2314341

Proc. of SPIE Vol. 10703 107033V-1

Two client instruments are visible above and on the side of NFIRAOS in Figure 1, attached to the IST by their own rotators and triangulated trusses. The thermal enclosure lies inside the IST, and has its own lightweight aluminum exterior structure, composed mostly of square grid framework. There is a third instrument port below NFIRAOS, where the IRIS instrument will attach. The right image is from a viewpoint from outside the dome looking past the Nasmyth platform towards the primary mirror of the telescope. The light from the telescope enters NFIRAOS' window on the far side in the right hand picture. Stair and walkways provide access around NFIRAOS to two doors, on each side of NFIRAOS, which provide access into the optics enclosure. Temporary servicing vestibules, seen in Figure 4, permits personnel access to NFIRAOS, while keeping out dirt, are removed in operation to reduce mass and wind cross-section.

2. TECHNICAL REQUIREMENTS OF NFIRAOS

Table 1 summarizes the key specifications for NFIRAOS that flow from the science goals for wide field precision astrometry and photometry with high sky coverage, good image quality, low background and very efficient usage of telescope time. These in turn demand that NFIRAOS optical design have very low (<0.05%) distortion, few surfaces, high efficiency coatings, good internal calibration sources, and to be able to quickly switch among three client instruments.

Table 1: Fundamental and derived requirements for NFIRAOS

Requirements	Derived AO design requirements
High sky coverage (50% at the galactic pole)	<ul style="list-style-type: none"> • Laser guide star (LGS) AO • Natural guide stars (NGS) in NIR to sense tip/tilt/focus • Multi-conjugate AO with 2 DMs to sharpen guide star images over a large field of view
Diffraction limited performance in J, H, and K bands (187nm/203nm RMS wavefront error on-axis /30" dia.)	<ul style="list-style-type: none"> • 6 LGS and tomographic reconstruction • High spatial (60x60) and temporal (800 Hz) sampling • AO telemetry and PSF reconstruction • Distortion-free optical design • High efficiency, uniform coatings
Astrometry (50 μ s precision across 30" FoV in H band in 100 s exposure)	
Photometry (2% accuracy across 30" FoV at $\lambda=1\mu$ m in 10 minute exposure)	
High optical throughput (80% over 0.8-2.5 μ m)	Cooled (-30°C) AO system with minimal number of optical surfaces.
Low background emission (15% of sky + telescope)	
Science ports (3 ports, f/15 with a 2' FoV)	Instrument selection mirror Common interface at 3 ports

3. NFIRAOS OPTICAL DESIGN OVERVIEW

Figure 2 presents an overview of the optical paths through NFIRAOS. The main science path is shown in red; light from the telescope first passes through an external calibration source for the instruments (not shown). This NFIRAOS Science Calibration Unit (NSCU) contains an integrating sphere with flat field and wavelength standards that will uniformly illuminate the focal and pupil planes. The NSCU has an input shutter, to permit daytime usage and to keep out dust when not observing and a deployment mechanism, which is normally parked out of the way to allow telescope light to pass into NFIRAOS.

Light then passes through the NFIRAOS entrance window (top center in Figure) into the cold enclosure, and arrives at the TMT focus. At this focal plane, the source simulator can deploy a pinhole mask, which can be illuminated by the NSCU. The pinhole mask also carries a fiber that will provide a central NGS source with three different intensities. Downstream of the TMT focus, an LGS simulator with 6 fibre sources in an EDM mount which minimizes vignetting can be deployed and translated along the optical path to simulate varying LGS ranges.

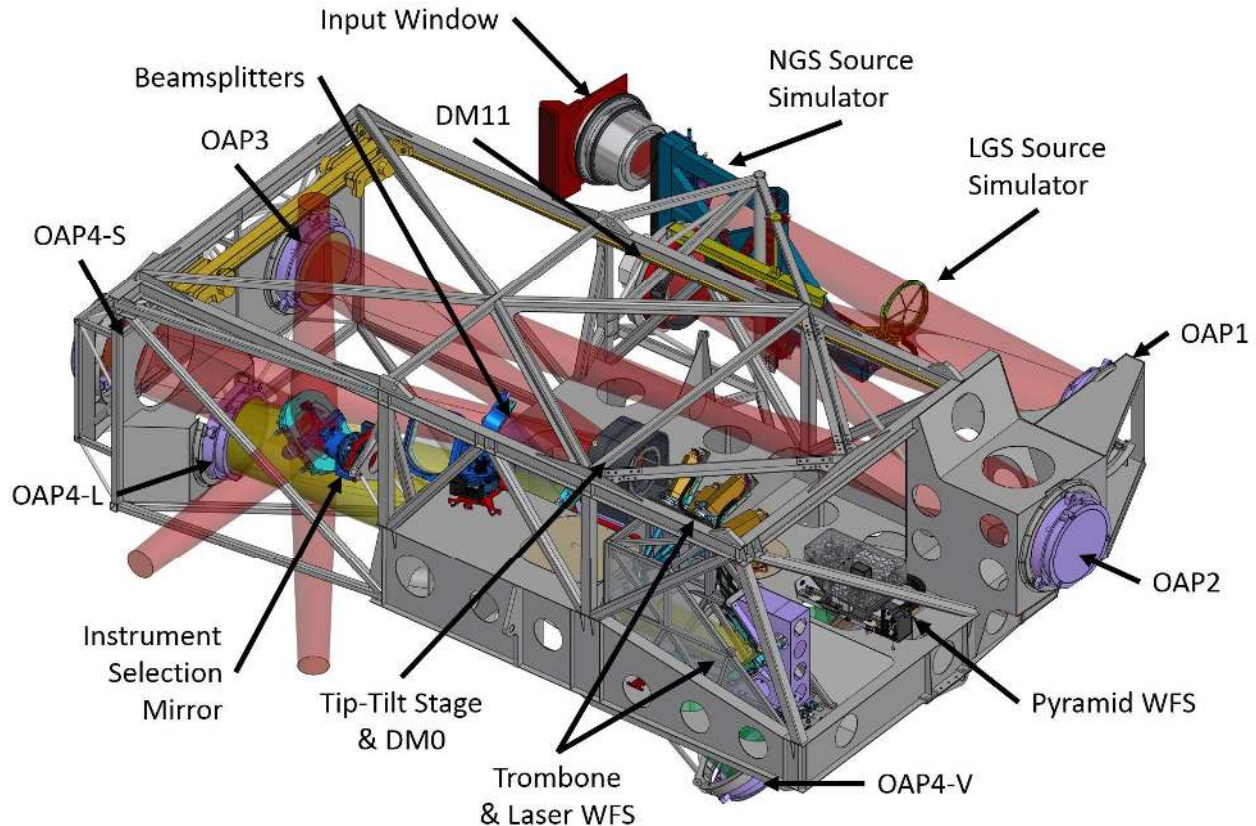

Figure 2: NFIRAOS optical table populated with subsystems

The science path is composed of two off-axis-paraboloid (OAP) mirror relays in series, each with a deformable mirror, the first of which (DM11) is conjugate to 11.8 km above the primary mirror, while the second (DM0) is conjugated to the ground. DM0 is carried in a large tip-tilt stage (TTS) assembly. The double OAP relay is required to cancel out both wavefront errors and distortion introduced by the OAPs. The near-IR light is transmitted through the science beamsplitter and reimaged by the last mirror of the second relay (OAP-S). After OAP4-S and on the way to focus, the beam is diverted up, down or sideways to the client instruments by the instrument selection mirror (ISM). During early operations, one of these clients will be a surrogate device (NSEN) that includes high resolution WFS (HRWFS) and diffraction-limited camera used to calibrate and characterize the performance of NFIRAOS.

Guide star light reflects off the science beamsplitter, and immediately the laser light is reflected out to the LGS WFS path with the LGS beamsplitter, where it is reimaged by OAP4-L, a copy of the fourth science paraboloid. A trombone stage compensates for changing LGS range distance to the sodium layer before the light reaches 6 Shack-Hartmann WFSs. Natural guide star visible (600 – 800 nm) light passes through the LGS beamsplitter, and is also reimaged by a 2nd copy of OAP-4S with the same prescription (OAP-4V), where it is measured by a pyramid WFS (PWFS) carried on an X-Y stage (star selection mechanism) that selects a single guide star from the field.

The CCD of the PWFS can be used both as the high temporal (800 Hz) and spatial (96x96) sampling NGS WFS in Single-Conjugate AO mode (without LGS) or it can be binned and read out at slow speed to serve as a 12x12 Truth WFS.

4. SUBASSEMBLIES OF NFIRAOS

In this section we describe various components of NFIRAOS. See Table 2 at the end of this section for the component specifications.

4.1 Instrument Support Tower and Optical Table

NFIRAOS can support three client science instruments (6800 kg each) and the NSCU while maintaining all NFIRAOS opto-mechanical components in a highly regulated cold environment. Structurally, these distinct functions are fulfilled by separate steel units: the IST and the TABL, an opto-mechanical structure (Figure 3). Due to the large loading during both normal operation and a possible seismic event, the IST is a large structural-steel framework, 10.4 m long \times 7.6 m wide \times 4.7 m high, constructed primarily from large welded girders and hollow structural steel members with a range of cross-sections.

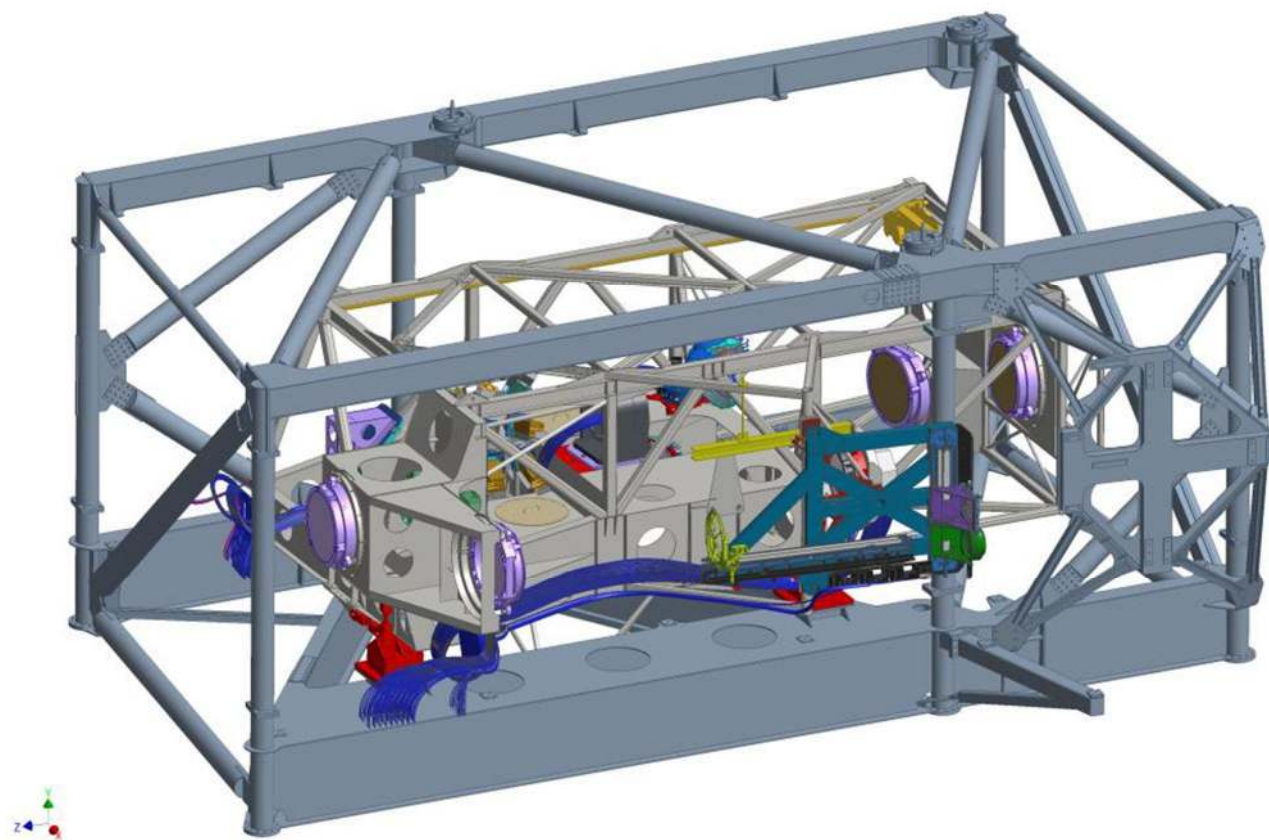

Figure 3: Isometric view showing the TABL supported inside the IST (note: the ENCL has been removed for clarity)

The NFIRAOS optical bench structure, or TABL, is the primary structure supporting the science, visible and laser-path optics within NFIRAOS and many related mechanisms. Numerous constraints influence the topology of the TABL structure, including: constraints imposed by the optical paths and opto-mechanical subsystem locations, constraints on the overall dimensions due to the optics enclosure and shipping and handling envelopes, and constraints on its interface with the IST. The structural connections between the IST and the TABL are implemented through multiple orthogonal linkages mounted to the top of the three thermal-isolation stubs. Six linkage elements define the six degrees of freedom for the TABL with respect to the IST. The IST and table were designed by Sightline Engineering with input from Dynamic Structures Ltd.

4.2 Optics Enclosure

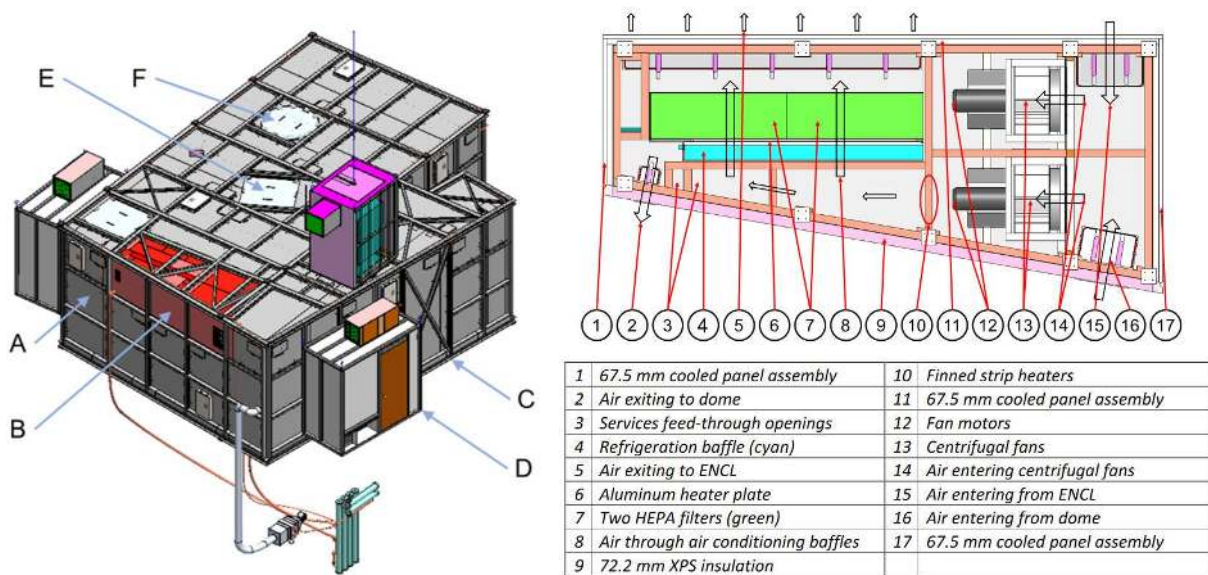

Figure 4 Left: ENCL overview, A – ENCL panels, B – Air Handling Unit (AHU), C – ENCL Framework, D – East gowning vestibule, E – DM0 vestibule hatch, F – Upper instrument port; Right: AHU overview

The left image in Figure 4 shows the NFIRAOS enclosure. Servicing vestibules are visible on the sides of NFIRAOS. On the left front in this picture (label F) is an insulated port plug which will be removed to install an instrument. There is a gate valve behind the port plug, permitting instrument exchange without warming NFIRAOS. The insulated enclosure walls are built from individual panels 150 mm thick, each with a buried cold plate approximately 1/4 of this distance from the inner surface. Each cold plate has an attached serpentine refrigeration channel, and the inlet mass flux is chosen to overfill a channel. That means some refrigerant (CO₂, also known as R-744) remains liquid at the exit at the bottom of each panel. This ensures a constant temperature across each panel, since there is always liquid to evaporate or vapour to condense if the heat leakage from the dome changes due to weather conditions. The panel temperature is controlled to $-30^{\circ}\text{C} \pm 0.5^{\circ}\text{C}$ by regulating the suction pressure at the exit of the panel, and therefore stabilizing the evaporation temperature within the panel. These cold panels consume ~ 3 kW of cooling power and maintain the temperature of the enclosure while avoiding vibration typical of conventional refrigeration systems with fans. There are also heaters on the exterior surfaces to keep them isothermal with the dome air to avoid condensation and cold plumes.

However, the panels would take nearly a week to warm or cool NFIRAOS to its operating temperature, so there is a powerful 25 kW air handling unit (label B) and detailed in the right image in Figure 4, which is responsible for cooldown, warmup and humidity control. With this unit, NFIRAOS can be cooled down or warmed-up within 20 hr. The enclosure was designed by Quantum Technology.

4.3 Entrance Window

Figure 5 shows a cross-section of the entrance window assembly and its penetration through the thermal enclosure (Section 4.2). A cross-section of the enclosure wall is shown in blue. The vacuum vessel is in light blue and the silica windows are clear yellow, with the outer window on the right facing the dome air, and the inner window on the left facing the -30°C air inside NFIRAOS. The left hand section of the vacuum vessel, protruding inside NFIRAOS has refrigerant coils to maintain it at -30°C . Inside the vacuum vessel are two thermally-controlled baffle sections, to radiatively heat and cool the outside and inside windows respectively and maintain each within $\pm 0.5^{\circ}\text{C}$ of the temperature of the air they are exposed to. Without these thermal baffles, the outer window would lose heat by radiation to the interior of NFIRAOS and possibly sub-cool below the dew point in the dome, causing condensation. As well, by maintaining a low temperature difference w.r.t. the dome and NFIRAOS air, the windows minimize self-induced turbulent “window seeing.” The right hand baffle is heated warmer than the dome, and the flat (right hand) surface of each baffle ring is highly emissive to warm the outer window and balance the heat loss to the interior of NFIRAOS. Meanwhile its curved surfaces are reflective (low emissivity) and act as Narcissus mirrors so that the opposite (further away) window sees itself in these reflective surfaces avoiding radiative

heat exchange with these curved surfaces. The left hand baffle section, near to the inner window is thermo-electrically cooled to $\sim -40^{\circ}\text{C}$, so that its emissive flat surfaces provide a cold load to balance the radiation from the outer window.

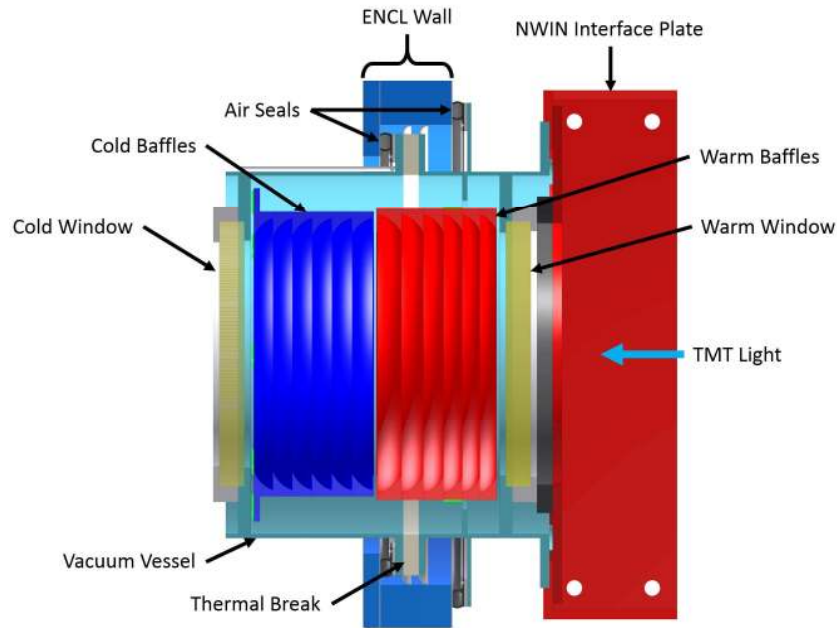

Figure 5 Evacuated double pane entrance window with warm and cold baffles

4.4 Source simulator

Just inside the entrance window, there is an assembly with several calibration sources. On the right Figure 6, is a Focal Plane Mask (FPM) with a grid of pinholes and a central NGS source. On the left side of Figure 6 is a LGS source assembly that flips into the beam and carries six fibre-fed sources that emit light at a wavelength of 589 nm. The LGS sources moves axially along the beam to simulate changing the LGS range distance to the sodium layer.

The FPM assembly is shown retracted just above and the NGS assembly (NGS assembly now removed from design) is shown retracted just below the telescope input focal plane respectively. They run on the same stage rails, and move separately into the focal plane, with appropriate electrical interlocks to prevent collisions. The FPM is illuminated by the NFIRAOS Science Calibration Unit (NSCU), an instrument wavelength and flat-field source, deployable in front of NFIRAOS' entrance window. The FPM has a central region with a dense grid of diffraction limited holes with 0.46 arcsecond spacing (1 mm physical distance), over-filling the science image detector (whose planned size is 34 arcseconds square) of IRIS, the first light client instrument. This mask can be dithered by ± 1.5 grid pitches in XY, to calibrate optical distortion to achieve the astrometry requirements. Outside this central region, a sparser grid of holes is available to calibrate pointing models for WFSs, and to fully illuminate DM11 for e.g. calibrating registration of WFSs to DM11.

As a cost saving exercise, the NGS assembly has been removed and replaced with a single NGS source mounted to the bottom of the FPM assembly. Additionally, the variable NGS source attenuation has been replaced with a source with 3 distinct intensities. The Source Simulator was designed by INO.

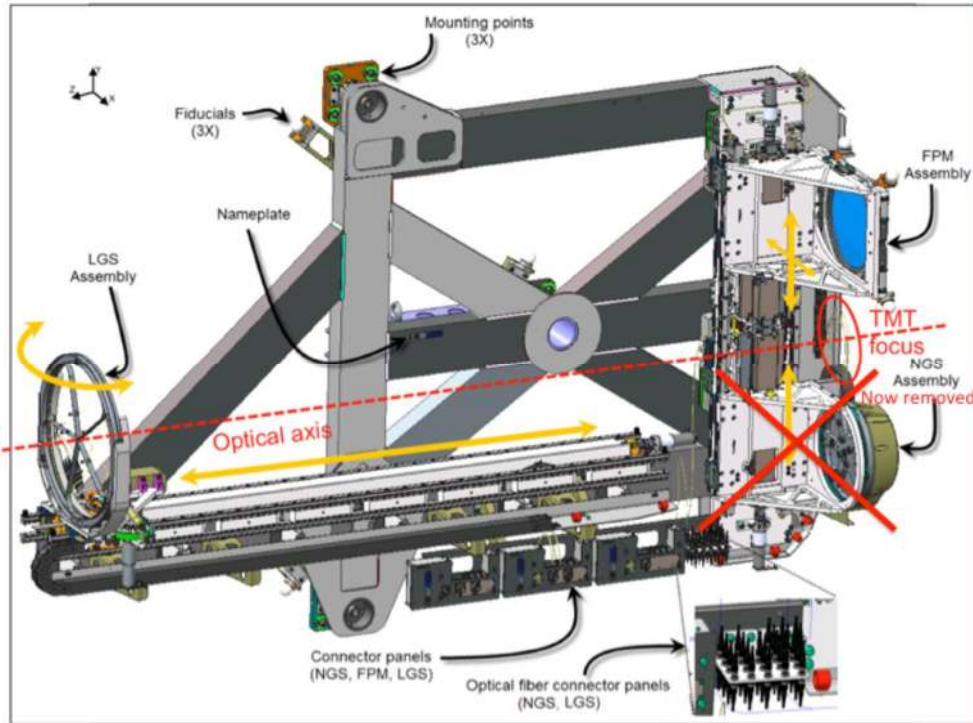

Figure 6 Left: Source Simulator; Right: Beamsplitter changing mechanism

4.5 OAP mirror cells

Figure 7 shows a mirror cell for an OAP. It has two large components: the OAP cell with a mirror, and an interface plate. These two are joined by three flexure adjustment mechanisms for tip/tilt alignment. These flexure mechanisms act as repeatable bayonets, permitting the removal and accurate replacement of a mirror plus its cell onto the interface plates that will remain permanently affixed to the optical table. The OAP mirror cells were designed by ABB.



Figure 7: OAP mirror cell with interface plate

4.6 Beamsplitters and changer

The main science beamsplitter is in a collimated beam after DM0, and is a dichroic on a fused silica substrate that transmits light in the wavelength range from 800 to 2400 nm, and reflects light shortward of 800 nm. It has an anti-reflective coating on the downstream surface, and has a slight curvature and wedge to displace and defocus ghost images outside of the AO control radius ("dark hole" of the primary image of a point source). The beamsplitter is on a changer mechanism, shown

in Figure 8. The second position of the changer contains an engineering beamsplitter, a partially-silvered 50/50 intensity splitter. Its main purpose is to permit visual alignment, described in Section 5 Optical Alignment Procedure, but it also assists the goal to do some astronomy in the 600 – 800 nm range.

The shorter wavelengths reflected from the front surface of the beamsplitter are immediately divided by a second, stationary, LGS beamsplitter that reflects the 589 nm laser light towards the LGS arm containing OAP4-L, and the trombone etc. Light passing through the LGS beamsplitter descends out of plane to OAP4-V, seen suspended below the optical table in Figure 2, and then is folded to reach the visible natural guide star wavefront sensor (VNW). The beamsplitters were designed by INO.

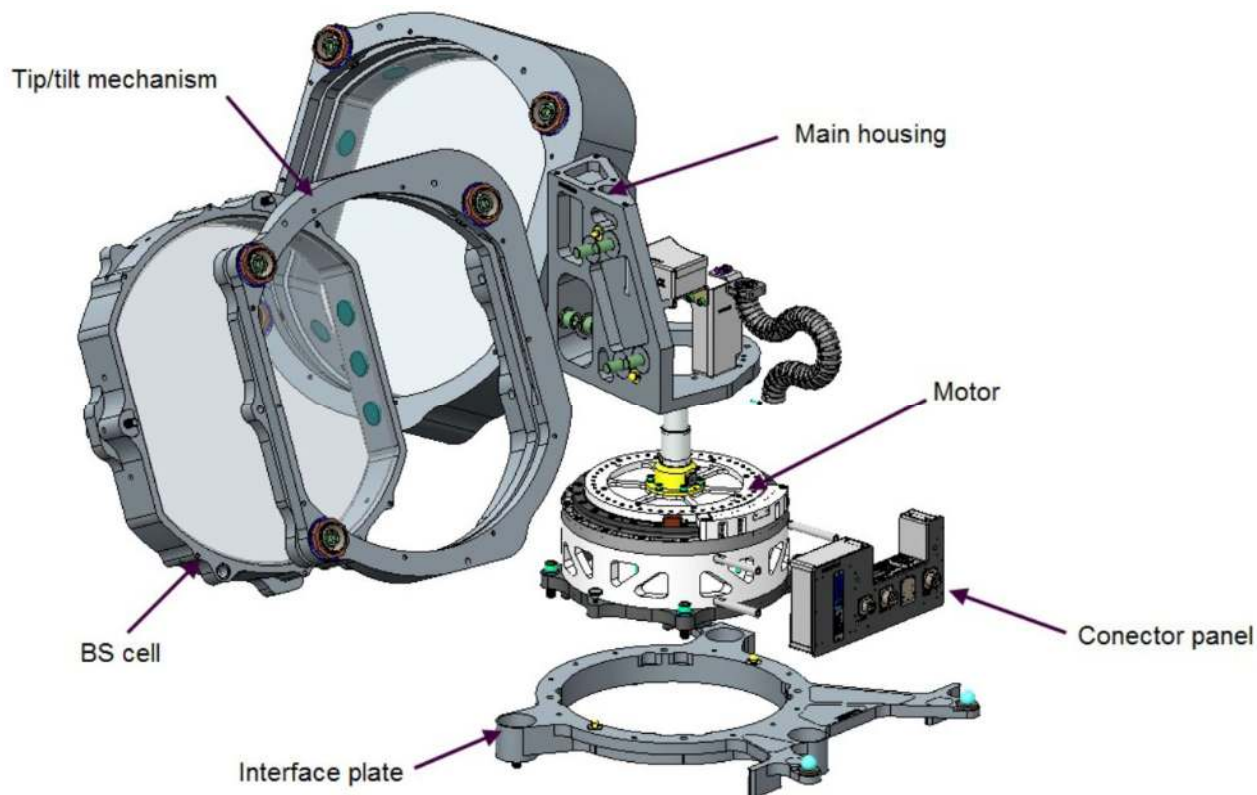

Figure 8: Science beamsplitter and changing mechanism

4.7 LGS Wavefront Sensors

Laser light, after reimaging by OAP4-L, does a double reflection from a pair of trombone mirrors, on a stage with >800 mm of travel. This trombone (Figure 9:) focuses the sodium layer onto the WFSs and is designed for range distances between 85 and 235 km. After the trombone, individual pick-off mirrors divert each laser guide star towards collimator lens barrels. Each barrel begins with an 8 arcsecond diameter field stop, and then re-images the pupil onto 30 mm diameter lenslet arrays. These lenslets are part of each camera assembly (VCAM), because of the tight tolerances needed (especially for clocking) between the lenslets and the CCD. This arrangement permits rapid repair of NFIRAOS by field-replacement of whole cameras, without re-aligning optics. The CCDs themselves are polar co-ordinate devices with compact islands of 0.8 arcsecond pixels aligned with the elongated laser spot images. Spot images are more elongated further towards the edge of the pupil because TMT uses a central laser launch telescope, so the CCD islands have 6x6 pixels behind lenslets near the centre, and 6x12 near the perimeter. This scheme reduces the total number of pixels needed and optimizes the tradeoff between laser power, readout noise and frame rate.

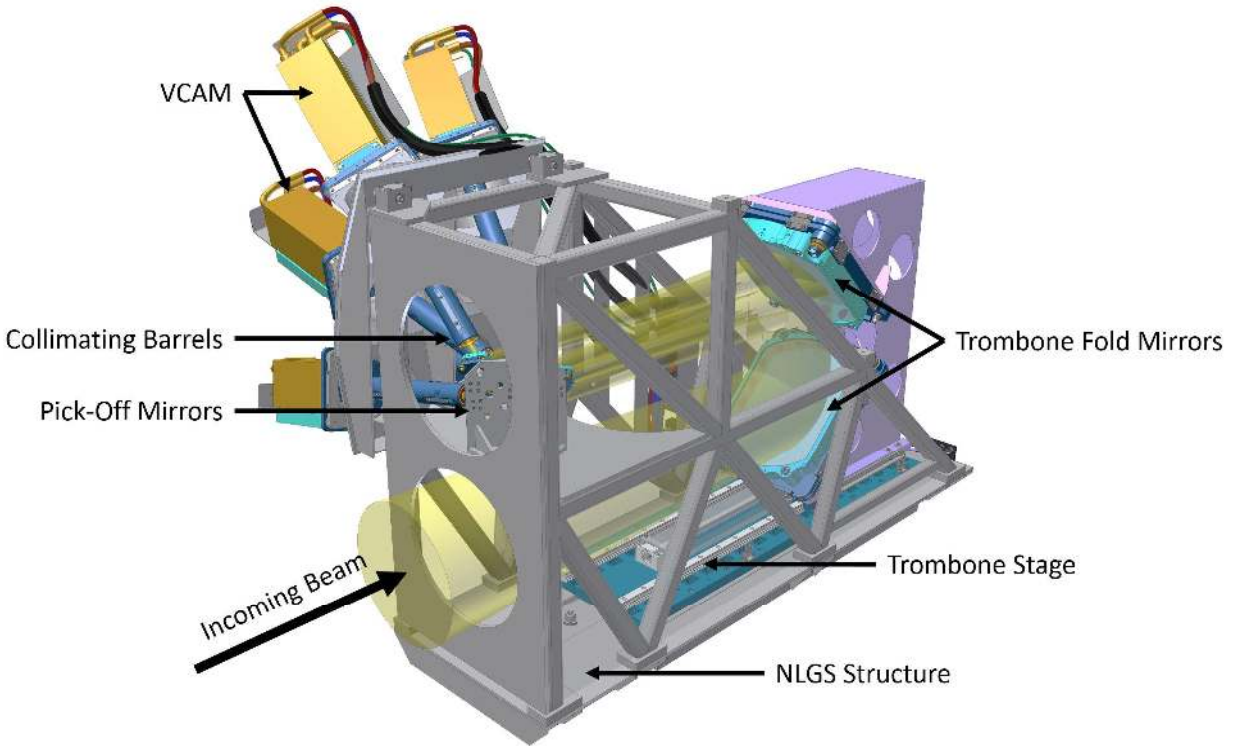

Figure 9: LGS Trombone and wavefront sensor assemblies.

4.8 Visible (NGS) wavefront sensor

The VNW (Figure 10) is a pyramid wavefront sensor (PWFS) that has two main roles: 1) a truth WFS for laser guide star MCAO mode; and 2) a high speed, high order WFS for NGS (SCAO) operation. Also its signals can stand in for one of the three On-instrument wavefront sensors (OIWFS), if a suitable guide star is not available near the science field. Since VNW is fed by a dichroic beamsplitter, it can operate arbitrarily close to any science target, whereas OIWFS pickoff mirrors can vignette the scientific targets if positioned too close (within 5 arcseconds).

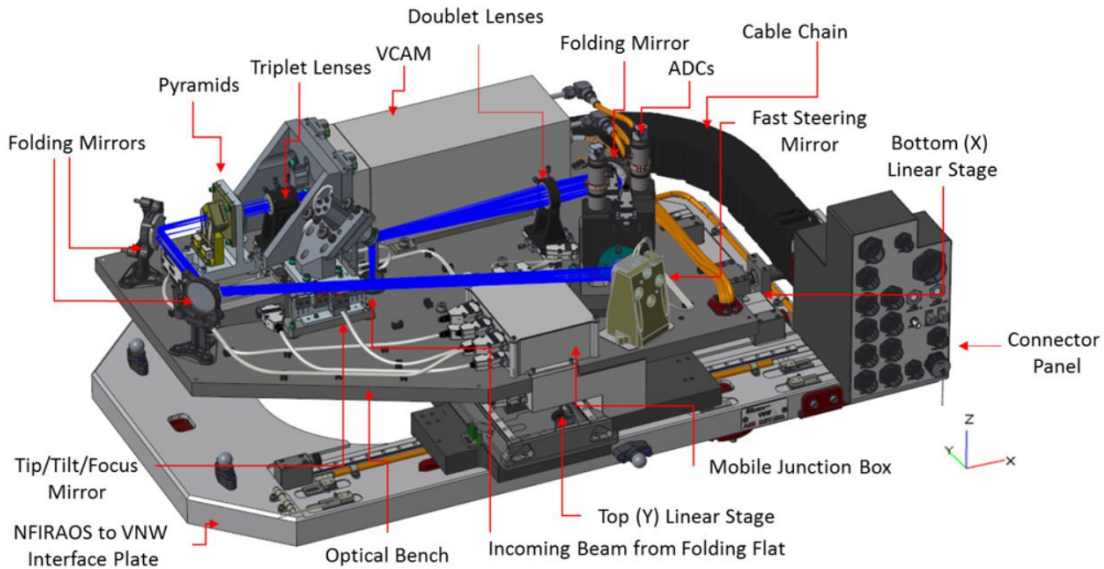

Figure 10: NGS star selection mechanism and pyramid WFS (VNW)

Light from OAP4-V is folded by two flat mirrors to arrive at VNW traveling upwards. The pyramid WFS is carried by an X-Y stage that patrols the 265 mm diameter (120 arcsecond) technical field-of-view and selects a single star using a pickoff mirror near focus. Because the focal plane is curved, this 45 degree fold mirror compensates for focus and pupil position with a tip/tilt/focus mirror mechanism. Thus a total of five mechanical axes form the star selection mechanism (SSM) to select a star and deliver its image onto the tip of the pyramid while centering the four pupil images correctly onto the detector.

On the way to the pyramid, the light passes through an atmospheric dispersion compensator (ADC) and reflects from a fast-steering piezo tip-tilt mirror that simultaneously modulates and dithers the beam. In NFIRAOS, modulation means making the beam travel in a circle (up to $10\lambda/D$, where $\lambda=700\text{nm}$ and $D=30\text{m}$) around the tip of the pyramid exactly once per frame to extend the dynamic range of the measurements. Dithering is a slower speed (typically $1/4$ frame rate) low amplitude ($\sim 1\%$ of modulation) circular waveform that the real time computer uses to assess optical gain of the PWFS. VNW was designed by ABB and INO. The VNW detector is a more conventional rectangular pixel array, housed in a camera that is mechanically identical to the LGS CCDs, but without a lenslet array. It employs the same electronics as the LGS WFSs, but with fewer readout boards.

Table 2: Component Specifications

Deformable mirrors	63x63 and 76x76 actuators at 5 mm spacing 10 μm stroke at -30°C , $\leq 2\%$ per time decade creep at -30°C
Tip/Tilt Stage	500 μrad stroke with 0.05 μrad angular resolution 80 Hz bandwidth
NGS WFS Detector	256x256 CCD, 96x96 virtual sub-apertures ~ 0.8 quantum efficiency, ~ 1 electron at 100 Hz frame rate
LGS WFS Detectors	60x60 sub-apertures with 6x6 to 6x15 pixels each ~ 0.9 quantum efficiency, 3 electrons at 800 Hz frame rate
Deformable mirrors	63x63 and 76x76 actuators at 5 mm spacing 10 μm stroke at -30°C , $\leq 2\%$ per time decade creep at -30°C
Tip/Tilt Stage	500 μrad stroke with 0.05 μrad angular resolution 80 Hz bandwidth

5. OPTICAL ALIGNMENT PROCEDURE

The integration plan for NFIRAOS begins by using a metrology bench to measure all OAPs mounted in their cells and interface plates, to determine the as-polished focal length, and the off-axis distance to the vertex in a local coordinate system defined by Spherical Magnetic Retroreflectors (SMR), which are permanently mounted to each interface plate. We will also apply a fiducial mark on each OAP indicating where we would like the chief ray to hit the mirror. Then using Zemax, we will re-optimize the planned locations of each OAP on the optical bench. First, we will install the interface plates separately and survey them into position in XYZ and clocking, using optical coordinate measuring machines to locate the SMRs within 50 μm , and then install the OAPs by inserting the cell and flexures into the interface plates. The optical axis will be established by the line joining the central hole in the focal plane mask, (Section 4.4) and the fiducial mark on OAP1. With an alignment telescope, we will look through the front window of NFIRAOS and boresight the telescope to these two features. Then we will re-focus the telescope onto the surface of OAP2, and using the flexure adjusters on OAP1 will tip and tilt OAP1 until we can view the OAP2 fiducial mark on axis. Then we will refocus the telescope onto the next optic (OAP3), and tip and tilt OAP2 until the next fiducial is in line, and repeat the procedure to the end of the optical path. Finally, the NSEN patrolling HRWFS on an instrument port will measure the output image position and pupil location so that NFIRAOS' instrument locating pins can be shimmed and/or translated so that an instrument can bolt on and be well-aligned with the expected optical beam.

6. REAL TIME COMPUTER

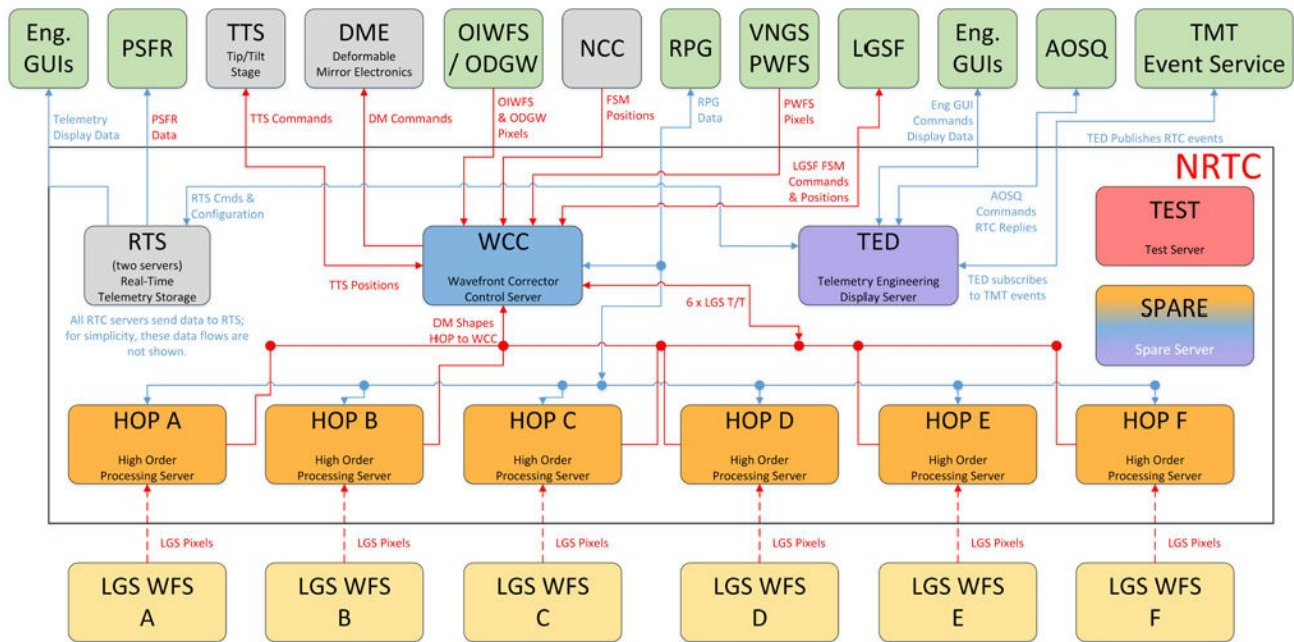

Figure 11: Real Time Computer Schematic – LGS MCAO mode

NFIRAOS RTC uses Intel Xeon servers, and does a matrix-vector multiplication on the WFS gradients to calculate DM actuator errors. In Figure 11, for LGS MCAO mode, the main data flow is from bottom to top. Each LGS WFS sends its pixels to its own private High-Order Processor (HOP) server with four 20-core CPUs, one CPU per quadrant of the CCD. These CPUs calculate gradients from each subaperture spot using a matched filter and then process a stripe of columns of the control matrix, with individual cores doing a piece of the stripe. One CPU in a HOP server adds the four partial DM error vectors and forwards them to the Wavefront Corrector Control (WCC) server that combines these as an input to the main control integrator. The WCC also processes pixels from: the truth WFS to correct errors from interaction of the sodium layer with the LGS WFS; plus (typically) three On-Instrument WFSs (OIWFS) measuring high-speed Tip/Tilt/Focus to control these three modes, plus plate scale; as well as low-data rate pixels from On-Detector Guide Windows (ODGW) on the science detectors, which are the long term references for flexure and rotator stability.

Data is archived on a pair of Real-time Telemetry Storage (RTS) servers, for diagnostics, but mainly for Point Spread Function Reconstruction (PSFW). This PSFR data will be overwritten each night by new data, and the calculated point spread functions will go into the science repository associated with each exposure. Other servers provide user interface GUIs and can stream test data through the RTC. Separate from the RTC there is another computer provided by TMT, the Reconstructor Parameters Generator (RPG), a farm of GPUs that will take RTC telemetry data and return a new control matrix to the RTC every 10 seconds.

The RTC resides in the TMT computer room, and has private Ethernet fibres through the telescope cable wrap directly to the RTC's own switch in the NFIRAOS electronics cabinet below NFIRAOS' enclosure as seen in Figure 12. These fibres convey pixels to the computer room and return DM and TTS commands to the NFIRAOS Nasmyth electronics cabinets that contain high-voltage DM amplifiers, and also motor controllers, refrigeration controllers and light sources for the Source Simulator.

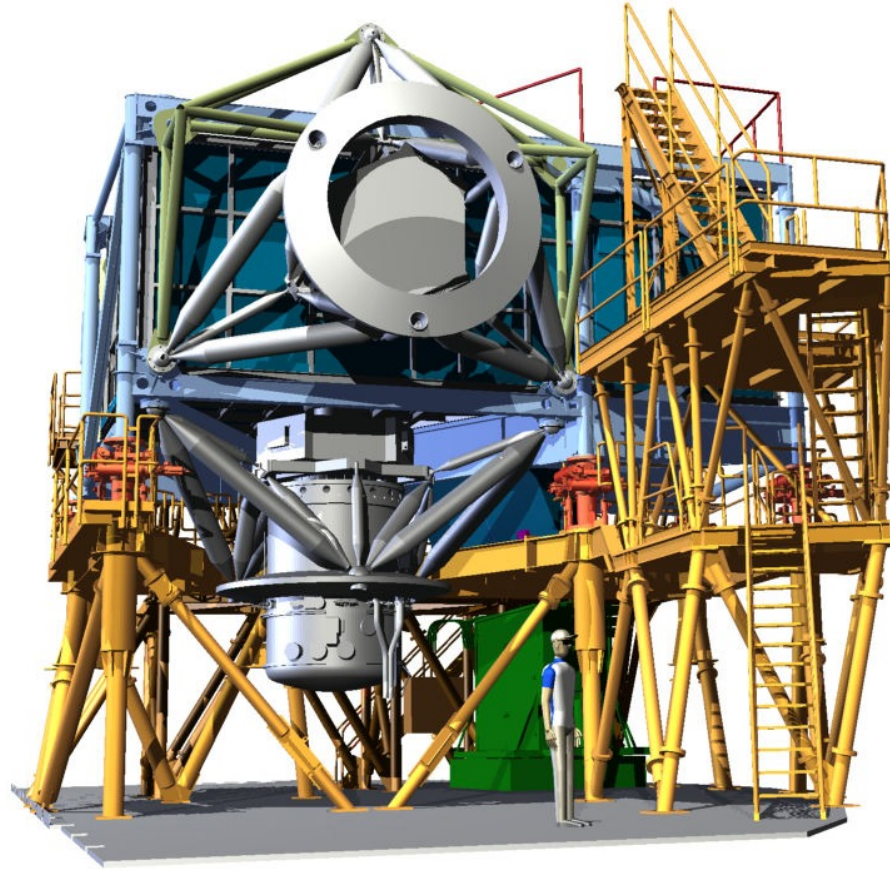

Figure 12: NFIRAOS on Nasmyth platform with IRIS underneath and NSEN on top

7. CONCLUSION

NFIRAOS for the Thirty Meter Telescope is currently completing its final design phase with its final design review scheduled for the end of June-2018. It is a multi-conjugate adaptive optics system with two deformable mirrors and six 60x60 LGS WFS, whose real time computer also makes use of inputs from up to three on-instrument WFSs in each of three client instruments observing in the near infra-red from 800 to 2400 nm. To reduce background emission, NFIRAOS is cooled to -30°C with a tight tolerance ($\pm 0.5\text{ C}$) and incorporates sophisticated humidity and temperature control including an evacuated entrance window.

8. UP NEXT

Following the June final design review, it is expected that a few minor updates will be completed based on the advice of the design review committee. This is in addition to some currently planned updates, mostly to reduce cost:

- The biggest update is to the refrigeration system. Currently completed is an R507 refrigerant design for the optics enclosure, but a change in the TMT supplied refrigerant to CO_2 requires a new detailed design of the refrigerant system for the NFIRAOS optics enclosure and for the electronic enclosure.
- The NFIRAOS source simulator currently has a dedicated NGS fibre-fed source assembly, but this is currently planned to be removed and a simplified to a single source mounted to the focal plane mask assembly.
- After TMT downselects the design of the NFIRAOS DMs, the NFIRAOS DM electronics design will be completed.
- The design of NSEN will be advanced from a preliminary state to final design.

9. REFERENCES

- [1] C. Boyer, "Adaptive optics program at TMT", This conference, Paper 10703-35
- [2] J. Dunn, D. Kerley "Final design of the real-time controller (RTC) for the narrow field infrared adaptive optics system (NFIRAOS) for TMT", This conference, Paper 10703-44
- [3] J. Crane, J. Atwood, "Design of a laser guide star wavefront sensor system for NFIRAOS", The conference, Paper 10703-132
- [4] K. Jackson, J. Véran, "Calibration and test procedures for the NFIRAOS deformable mirror prototypes", This conference, Paper 10703-261
- [5] G. Herriot, J. Véran, "Point Source sensitivity, Pupil alignment, Calibration and Control for TMT-NFIRAOS-IRIS", AO4ELT5 conference proceedings (2017)
- [6] J. Atwood, J. Crane, "Non-sequential design of a thermal radiative baffle for NFIRAOS", Proc. SPIE 10590, International Optical Design Conference 2017, 1059022 (27 November 2017)