

AL-SR-1992-0002

AD-A257 059



Night Vision Manual for the Flight Surgeon



August 1992

Special Report for Period August 1985 - April 1992

Approved for public release; distribution is unlimited.

ROBERT E. MILLER II, Colonel, USAF, BSC
THOMAS J. TREDICI, Colonel, USAF, MC (RET)

OPHTHALMOLOGY BRANCH
ARMSTRONG LABORATORY
HUMAN SYSTEMS CENTER (AFMC)
BROOKS AIR FORCE BASE, TX 78235-5000

32-27409

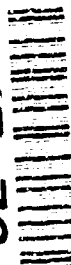

2

NOTICES

When Government drawings, specifications, or other data are used for any purpose other than in connection with a definitely Government-related procurement, the United States Government incurs no responsibility or any obligation whatsoever. The fact that the Government may have formulated or in any way supplied the said drawings, specifications, or other data, is not to be regarded by implication, or otherwise in any manner construed, as licensing the holder, or any other person or corporation; or as conveying any rights or permission to manufacture, use, or sell any patented invention that may in any way be related thereto.

The Office of Public Affairs has reviewed this report, and it is releasable to the National Technical Information Service, where it will be available to the general public, including foreign nationals.

This report has been reviewed and is approved for publication.

ROBERT E. MILLER II, Col, USAF, BSC
Project Scientist

DOUGLAS J. IVAN, Col, USAF, MC, FS
Chief, Ophthalmology Branch

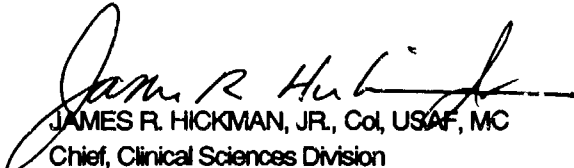
JAMES R. HICKMAN, JR., Col, USAF, MC
Chief, Clinical Sciences Division

REPORT DOCUMENTATION PAGE

Form Approved
OMB No. 0704-0188

Public reporting burden for this collection of information is estimated to average 1 hour per response, including the time for reviewing instructions, searching existing data sources, gathering and maintaining the data needed, and completing and reviewing the collection of information. Send comments regarding this burden estimate or any other aspect of this collection of information, including suggestions for reducing this burden, to Washington Headquarters Services, Directorate for Information Operations and Reports, 1215 Jefferson Davis Highway, Suite 1204, Arlington, VA 22202-4302, and to the Office of Management and Budget, Paperwork Reduction Project (0704-0188), Washington, DC 20503.

1. AGENCY USE ONLY (Leave blank)		2. REPORT DATE August 1992	3. REPORT TYPE AND DATES COVERED Final - August 1985 - April 1992	
4. TITLE AND SUBTITLE Night Vision Manual for the Flight Surgeon			5. FUNDING NUMBERS PE - 62202F PR - 7755 TA - 24 WU - 08	
6. AUTHOR(S) Robert E. Miller II Thomas J. Tredici				
7. PERFORMING ORGANIZATION NAME(S) AND ADDRESS(ES) Armstrong Laboratory Aerospace Medicine Directorate Clinical Sciences Division Brooks Air Force Base, TX 78235-5000			8. PERFORMING ORGANIZATION REPORT NUMBER AL-SR-1992-0002	
9. SPONSORING/MONITORING AGENCY NAMES(S) AND ADDRESS(ES)			10. SPONSORING/MONITORING AGENCY REPORT NUMBER	
11. SUPPLEMENTARY NOTES				
12a. DISTRIBUTION/AVAILABILITY STATEMENT Approved for public release; distribution is unlimited.			12b. DISTRIBUTION CODE	
13. ABSTRACT (Maximum 200 words) This manual is an updated and extensively revised successor to the 1985 edition of the Night Vision Manual for the Flight Surgeon (USAFSAM-SR-85-3). It is a definitive reference that provides current guidance for flight surgeons who can use it as a source document in providing night vision briefings, conducting NVG training sessions, discussing aeromedical limitations, and applying appropriate medical standards. This document can also be used by the flight surgeon in conjunction with night vision demonstration kits and other teaching aids.				
14. SUBJECT TERMS Field of view Flight surgeon Night Vision Goggles (NVG)			Night vision physiology NVG preflight testing procedures Ophthalmologist	Optometrist Rods and cones Unaided night vision
			15. NUMBER OF PAGES 114	16. PRICE CODE
17. SECURITY CLASSIFICATION OF REPORT Unclassified	18. SECURITY CLASSIFICATION OF THIS PAGE Unclassified	19. SECURITY CLASSIFICATION OF ABSTRACT Unclassified	20. LIMITATION OF ABSTRACT UL	

DTIC
SELECTE
OCT 20 1992
S B D

CONTENTS

CHAPTER		Page
1	THE ROLE OF THE FLIGHT SURGEON	1
	OVERVIEW OF AEROMEDICAL RESPONSIBILITIES	1
	EDUCATION AND TRAINING	1
	UNAIDED NIGHT VISION	2
	PROFICIENCY IN THE NVG TEST LANE	2
	PREFLIGHT TESTING PROCEDURES	3
	AEROMEDICAL GUIDANCE	6
2	NIGHT VISION IN THE UNAIDED EYE	9
	THE EYE	9
	PHOTOPIC VERSUS SCOTOPIC VISION	9
	MESOPIC VISION	10
	DARK ADAPTATION	10
	CENTRAL BLIND SPOT AT NIGHT	13
	SPECTRAL SENSITIVITY	17
	PURKINJE SHIFT	17
	PHOTOCHROMATIC INTERVAL	17
	NIGHT BLINDNESS	18
	TESTS OF NIGHT VISION	18
3	OPERATIONAL ASPECTS OF NIGHT VISION	23
	INTRODUCTION	23
	CONTRAST DISCRIMINATION	23
	NIGHT MYOPIA	23
	ENHANCING AND MAINTAINING DARK ADAPTATION	25
	Red Goggles	25
	Flash Blindness	25
	Daytime Exposure	27
	COCKPIT ILLUMINATION	27
	VISUAL ILLUSIONS AT NIGHT	28
	Autokinetic Effect	28
	Black Hole Illusion	28
	Distance Illusion Phenomenon	29
	False Perceptions	29
	DRUGS	30

CONTENTS (Continued)

CHAPTER	Page
TOBACCO	30
HYPOXIA	31
NIGHT VISION DEVICES	31
RECOMMENDATIONS	33
 4 INTRODUCTION TO NIGHT VISION GOGGLES (NVG)	 35
HISTORY	35
ELECTRO-OPTICAL DESIGN	35
OPERATIONAL PERFORMANCE	40
AN/PVS-5A	40
ANVIS	41
Cats-Eyes	43
PERFORMANCE LIMITATIONS	44
Visual Acuity/Resolution	44
Field of View	45
Binocular Versus Biocular Vision	46
Depth Perception	48
Other Parameters	49
 5 NVG AND HUMAN FACTORS CONCERNS	 51
OPERATIONAL ISSUES	51
INTEGRATION WITH LIFE-SUPPORT EQUIPMENT	52
COMPATIBLE COCKPIT LIGHTS	53
ENVIRONMENTAL CONSIDERATIONS	54
FATIGUE	56
NVG ACCIDENTS AND EYE PROTECTION	58
 ACKNOWLEDGMENTS	 60
 REFERENCES	 61
 APPENDIX A. ANVIS ADJUSTMENT PROCEDURES	 67
 APPENDIX B. REPORT OF LITERATURE REVIEW: SMOKING AND NIGHT VISION	 91
 APPENDIX C. DESCRIPTION OF AN/PVS-5 NVG	 97

CONTENTS (Continued)

APPENDIX D. DESCRIPTION OF ANVIS	Page 99
APPENDIX E. ANVIS VERSUS AN/PVS-5	101

FIGURES

<u>Figure No.</u>		<u>Page</u>
1-1	Light modification procedure for NVG test lane	5
1-2	USAF aircraft quantity and aircrew positions requiring the use of NVG	8
2-1	Schematic diagram of the eye	11
2-2	Brightness range over which the human eye can adequately function	12
2-3	Dark adaptation curve	14
2-4	Distribution of rods and cones for the right eye as seen from above. Note the complete absence of cones in the fovea and the high density of rods in the midperiphery	15
2-5	Central 1-degree blind spot at night. Objects that may not be seen at night if central fixation is used	15
2-6	Physiologic blind spot demonstration	16
2-7	Visible portion of the radiant energy spectrum	19
2-8	Luminosity curves for scotopic (rod) and photopic (cone) vision (Purkinje shift)	20
3-1	Ocular spherical aberration	24
3-2	Ocular chromatic aberration--distance object	26
3-3	Ocular chromatic aberration--near object	26
3-4	Night Vision Device (NVD) block diagram	32

FIGURES (Continued)

Figure No.		Page
3-5	FLIR field of view versus NVG field of regard	33
4-1a	AN/PVS-5 (II-Gen) NVG full faceplate modified version	36
4-1b	AN/PVS-5 (II Gen) NVG modified version	36
4-2	ANVIS (III-Gen) NVG	37
4-3	Cats-Eyes NVG	37
4-4	Schematic of photocathode tube	38
4-5	Microchannel plate function	39
4-6	Spectral output of the NVG phosphor screen	40
4-7	Spectral comparison of the II- and III-Gen photocathode tubes and spectral distribution of the night sky (starlight)	42
4-8	Unaided binocular field of view	47
4-9	Relationship between designed eye position and eye relief	47

TABLES

Table No.		Page
1	ELECTRO-OPTICAL SPECIFICATIONS OF NVG	41

PREFACE

Recent conflicts have shown that night missions are an essential part of modern warfare. Accordingly, the U.S. Air Force must continue to train for and maintain an around-the-clock operational capability with great emphasis on night operations. In support of this goal, the Ophthalmology Branch of the Aerospace Medicine Directorate, Armstrong Laboratory, Brooks AFB, Texas, implemented a program to study visual performance at night. The objectives were to evaluate night vision screening devices, establish norms for night vision in flying personnel, review training and enhancement techniques, determine the effects of various nutrients and drugs, and investigate image-intensifying devices, i.e., night vision goggles (NVG). A primary objective was to improve the educational level of USAF flight surgeons, ophthalmologists, and optometrists concerning the aeromedical aspects of night vision and NVG technology. This manual is intended to present an updated summary of this information to those medical and medical service personnel who provide direct support to operational units. The chapters are arranged to provide a comprehensive review of the operational aspects of night vision physiology and visual illusions, NVG technology, the capabilities and limitations pertinent to the flyer, and the role of the flight surgeon.

Please direct any comments or questions to the authors at (512) 536-3250/2745 or DSN 240-3250/2745.

ROBERT E. MILLER II, Col, USAF, BSC
THOMAS J. TREDICI, M.D.
Ophthalmology Branch
Armstrong Laboratory (ACCO)
Brooks AFB, TX 78235-5000

Accession For	
NTIS GRA&I	<input checked="" type="checkbox"/>
DTIC TAB	<input type="checkbox"/>
Unannounced	<input type="checkbox"/>
Justification	
By _____	
Distribution/	
Availability Codes	
Dist	Avail and/or Special
A-1	

NIGHT VISION MANUAL FOR THE USAF FLIGHT SURGEON

CHAPTER 1

THE ROLE OF THE FLIGHT SURGEON

OVERVIEW OF AEROMEDICAL RESPONSIBILITIES

Aircrew members should receive initial night vision training, attend appropriate aeromedical and safety briefings, and undergo proficiency testing by life-support personnel at the flying squadron before flying with night vision goggles (NVG). The flight surgeon, with the help of the base optometrist or ophthalmologist, is expected to play an important role in this program. The flight surgeon is responsible for providing NVG safety briefings and the necessary aeromedical support to ensure that aircrew members are familiar with the unique aspects of night vision physiology, are aware of the potential problems with visual illusions at night, are fully educated about the limitations induced by NVG wear, and are properly informed on how to achieve optimal visual performance with NVG. To achieve safe and maximal operational function with NVG, aircrew must be fully cognizant of not only the capabilities of these complex devices, but also their inherent performance limitations.

The flight surgeon should be able to interpret and appropriately apply visual standards to NVG wearers. The current USAF regulation (AFR 160-43, (C5), para 9-13, 29 April 1988) does not require clinical testing with NVG, i.e., no additional testing in the eye or flight medicine clinic; only the normal visual standards for aircrew need be met. Clinical testing is not required because spectacles can be worn compatibly with the current NVG, except for those few aircrew members who still wear the unmodified version (full faceplate) of the AN/PVS-5. For those NVG users who wear spectacles, special safety lenses for eye protection are specifically authorized. The use of soft contact lenses by spectacle-wearing aircrew has confounded the problem of providing ocular protection.

The flight surgeon can be a consultant to flying squadrons in setting up NVG training and testing rooms (NVG test lanes). The NVG test lane provides an appropriate area for night vision education, NVG training and testing, and preflight checkout.¹ In the NVG test lane it is possible to demonstrate the procedures for adjusting the NVG dioptric focus to maintain relaxed ocular accommodation, minimizing eye relief to maximize the field of view, and setting the interpupillary distance properly.² Flight surgeons should provide periodic and active support to the operational units that use NVG.

EDUCATION AND TRAINING

Flight surgeons are responsible for providing their flying squadrons with flying safety briefings on night vision and NVG at least annually. The aeromedical briefings

should be given more often if operational problems and/or high incident rates occur. The briefings should include a review of the physiology of unaided night vision, visual illusions at night, NVG capabilities, operational performance limitations, and human factors issues. The last four chapters and appendixes of this manual can be used as reference material for these briefings.

UNAIDED NIGHT VISION

Although the initial briefing by the flight surgeon should be primarily devoted to NVG, a significant portion should address the unaided eye at night. Information about night vision physiology is important because not all night flyers use night vision devices to enhance their vision. This information also provides a good background for NVG concepts, and there may be times, e.g., in bright moonlight, changing cloud conditions, etc., when some aircrew members will flip up their NVG and use unaided night vision. Thus, unaided night vision physiology is still very important.

Research optometrists at the U.S. Naval Aerospace Medical Institute and at the Aerospace Medical Research Laboratory, Pensacola, Florida, have co-developed a simple and inexpensive night vision demonstration program. This unaided night vision training guide includes a series of demonstration slides (35 mm), easy-to-follow directions, and an accompanying narrative³ which can be shown in a minimally modified room and completed in less than 1 hour. The presentation provides a good review and graphic demonstration of unaided night vision physiology, some operational aspects of using the eyes at night, and common visual illusions. This demonstration kit and training guide can be obtained by writing the following address:

Project Officer, Night Vision Research
Naval Aerospace Medical Research Laboratory
Naval Air Station
Pensacola, FL 32508

DSN 922-8072/3287

PROFICIENCY IN THE NVG TEST LANE*

Proficiency in adjusting and focusing NVG can be evaluated at the squadron NVG testing lane by life-support personnel. The testing does not have to be accomplished by the flight surgeon. However, the flight surgeon is responsible for periodically monitoring the procedures and equipment used in the NVG test lane to ensure that squadron personnel are using proper techniques for adjusting their NVG prior to flight.

The aircrew member can demonstrate proficiency in adjusting NVG by achieving the optimal binocular visual acuity appropriate for the version being used, i.e., 20/40

*Armstrong Laboratory Aircrew Training Research Division, Williams AFB, Arizona, is working to define exactly how to set up an NVG test lane.² Specific guidance for the test room parameters, procedures, lighting, targets, etc., is anticipated in the near future.

with ANVIS, 20/50 with AN/PVS-5, 20/50 with Mark IV Cats-Eyes, and 20/70 with Mark III Cats-Eyes (see Chapter 4). If an individual fails to achieve the optimal VA, the NVG used for testing should be evaluated and/or the proper procedures for adjusting and focusing the NVG should be reviewed with the aircrew member (see Chapter 4). Those aircrew members whose binocular VA with NVG is still found to be below optimal standards should be referred to their flight surgeon. The flight surgeon should consult with an ophthalmologist or optometrist to determine whether ocular pathology or changes in refractive error are present. Consultants in optometry and ophthalmology who are providing direct support to unit flight surgeons in evaluating crewmembers should become familiar with the NVG through actual use, if possible.

PREFLIGHT TESTING PROCEDURES

U.S. Army officials have reported a significant number of defective NVG tubes from units using the AN/PVS-5.⁴ Recently, a limited study by the Armstrong Laboratory Aircrew Training Research Division, Williams AFB, Arizona, found that 8 out of 20 ANVIS NVG had defective tubes. For this reason, it is important to carefully evaluate each NVG before it is used during night operations.

Preflight evaluation of the NVG is required by all aircrew members and is especially important for those in primary control of aircraft. Aircrew members must ensure that their NVGs are not defective and that they are providing optimal operational vision. Crewmembers who wear spectacles to correct refractive errors and those who wear contact lenses, as well as those who do not need any visual correction, must know how to comfortably fit, focus, and adjust their NVG.

Preflight testing of NVG should be conducted at the flying squadron by life-support personnel. Unit flight surgeons, with the help of base optometrists or ophthalmologists, can assist life-support personnel in properly setting up the preflight testing equipment in the NVG test lane. Personal equipment/life-support sections (at bases with NVG missions) are responsible for obtaining the necessary NVG testing equipment.^{2,5} The flight surgeon will periodically spot-check the preflight testing procedures of aircrew members.

Until the proper test equipment for preflight testing is available, the following procedure (also see Appendix A) may serve as an evaluation method for the NVG.

A. Equipment

1. A relatively light-tight room at least 6.1 m (20 ft) long by 3.05 m (10 ft) wide, preferably with no windows
2. A square grating chart (available from AL/CFHO, Wright-Patterson AFB, Ohio) or a Snellen Visual Acuity Eye Chart (NSN-6515-00-598-8075)
3. The NVG and the appropriate operator's manual⁶

4. A small lamp with an opaque cover that has a 9.5 mm (3/8-in.) hole cutout modification (Fig. 1-1)

B. Procedure

1. Place the visual acuity chart 6.1 m (20 ft) away from the observer.
2. Turn the lights out.
3. Turn the NVG to the ON position (not IR position).
4. Illuminate the acuity chart with the modified lamp, which should be held 3.05 m (10 ft) away from the chart.
5. Focus each I² tube with both the diopter ring and the objective focusing knob. At 6.1 m (20 ft), the objective focusing knob should be set near the infinity position; however, it may need readjusting for farther distances when being used at operational ranges. Turn the dioptic ring all the way counterclockwise and then back clockwise until the first clear focus is obtained. Repeat the focusing procedures for the objective and dioptic adjustments for final fine tuning.
6. Adjust the interpupillary distance between the tubes to correspond to the ocular interpupillary distance, then tighten the lever clamp. Personnel who have an interpupillary distance greater than 74 mm or less than 51 mm will not be able to use the NVG properly.
7. Measure the best visual acuity with the goggles for each eye and for both eyes together, after focusing and adjusting each eye separately.
8. To check the amplification of each tube compared with the other, see if one tube is darker than the other under low light levels. The eyes will rapidly adjust separately to different luminance, so the NVG should be removed from the eyes for 15-30 seconds prior to this check.
9. If the tubes seem to have defective light amplification, a known set of good NVG should be used for comparison. With experience, the NVG evaluator will be able to detect the lack of gain, if both tubes are defective, by the decreased brightness and resolution of the eye chart for a given test location and condition.
10. Approximately 20/50 binocular visual acuity is the best obtainable with the AN/PVS-5 (20/40 with the ANVIS) and Cats-Eyes using this procedure.⁷ Considerable variability from this level of performance can be expected with initial users of the NVG, and will most likely be due to the user's inability to accurately focus both the diopter ring and the focus knob, and/or adjust for tilt, interpupillary distance, or eye relief.⁸

**Front view of Black Matting
with 5-mm Aperture**

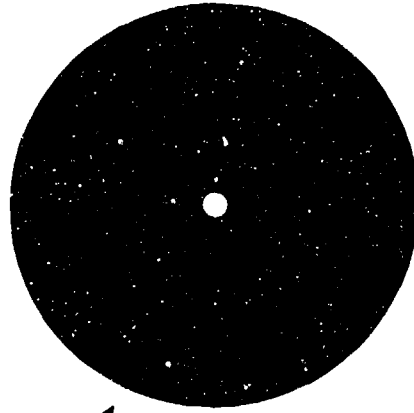

Trace from Light Fixture

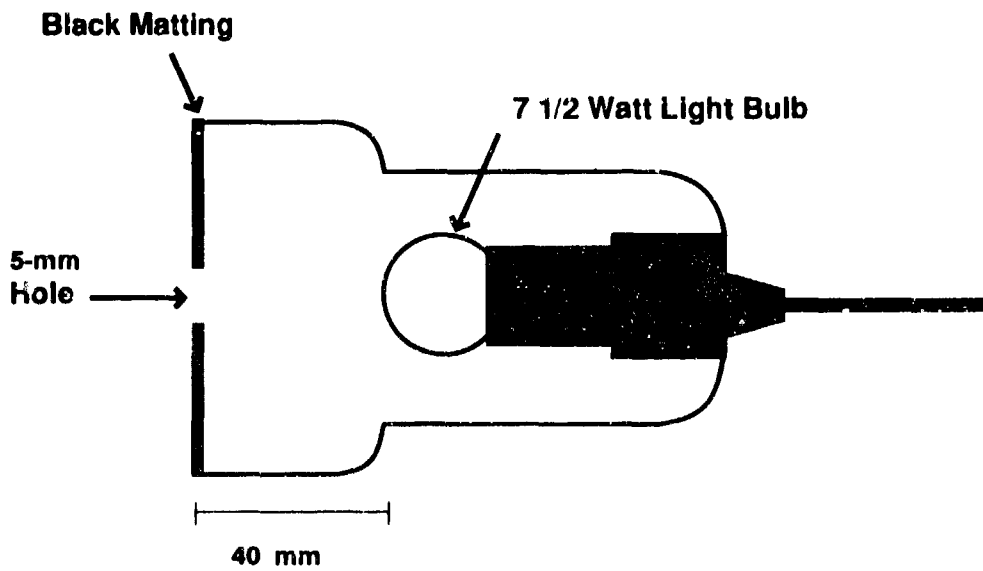

Figure 1-1
Light modification procedure for NVG test lane

AEROMEDICAL GUIDANCE

According to AFR 60-16, para 6-3c, 3 March 1989, aircrew members must be checked by a unit flight surgeon before using NVG during night training or operational missions to ensure that NVG do not impair their vision. Essentially, this means that the flight surgeon is responsible for making sure that aircrew members know how to fit, adjust, and focus their NVG, and that they can achieve optimal visual proficiency. Much of the pertinent information can be presented at the NVG safety briefings given by the flight surgeon.

The flight surgeon should screen medical records to confirm that each aircrew member has passed the most recent annual vision screening and attained 20/20 VA at both distance and near, either with or without spectacles, according to AFR 16-43, November 1989. Documentation of this review should be entered in the records. Only crewmembers failing that screening, or those complaining of visual problems, should be referred for routine clinical eye examinations. Measurement of visual acuity with NVG in the clinic eye lane by an optometrist or ophthalmologist is not required.

The flight surgeon should ensure that individual aircrew members understand how to properly fit, adjust, and focus their NVG. Proficiency at using NVG can be evaluated in the NVG test lane by individual crewmembers and life-support personnel. The testing does not have to be accomplished by the flight surgeon. However, the flight surgeon should occasionally verify the calibration of the NVG test lane, the accuracy of the preflight testing procedures, and the performance of squadron personnel. If problems are discovered and validated by operational personnel, consideration should be given to conducting refresher training for the whole squadron. The reader is referred to AFR 60-16, para 6-3c, 3 March 1989, and AFR 160-43 (C5), para 9-13, 29 April 1988, for specific guidance.

Aircrew members who are candidates for initial assignment to a flying unit with an NVG requirement (Fig. 1-2) must meet the physical standards of Flying Class II or III before assignment actions are finalized. The Flight Surgeon's Office at the base where the candidate is currently assigned will screen the candidate's medical records. If the records review reveals that the candidate meets the specified standards, either with or without spectacles, then the flight surgeon can medically clear the candidate for assignment. If the records review reveals that a flyer's acuity (with or without spectacles is not 20/20 in each eye, then the flight surgeon will recommend an eye examination. Candidates who subsequently meet the standards may be medically cleared for assignment. (NOTE: Measurement of VA with NVG is not required as part of the preassignment medical evaluation.)

Once at the gaining base, aircrew members who are unable to achieve the optimal binocular vision through the NVG should be retested. Before retesting, the NVG should be checked for performance deficiencies, and proper adjusting and focusing techniques should be reviewed. Only if aircrew members fail the visual acuity test again is it necessary to refer them to the base medical facility for a complete eye examination, including refraction. Aircrew members currently qualified to use NVG, but unable to meet the standards specified in the Aeromedical Standards paragraph, may be provided a waiver if it can be clearly demonstrated that their ability to perform

with NVG is not impaired. Since the effects of altered visual function, i.e., ocular pathology, on overall NVG performance have not been studied, the use of waivers should be very specially considered. The waiver authority for rated aircrew members is HQ USAF/SGPA. For nonrated aircrew members, the waiver authority is MAJCOM/SGPA.

Consult the HQ USAF/SGP contact lens implementation plan for guidance on fitting contact lenses for aircrew members who use NVG. The flight surgeon will assist the squadron in obtaining appointments for eye examinations and contact lens follow-up evaluations, as necessary. Aircrew requiring contact lenses for medical or severe optical problems must still be referred to the Aeromedical Consult Service, Ophthalmology Branch, Brooks AFB, Texas. Spectacle-wearing aircrew members who are required to use NVG may want to have a complete eye examination, including refraction, at least every two years to complement their annual Flying Class II physical examination.

Finally, the flight surgeon is responsible for advising spectacle-wearing aircrew who use NVG that they can procure safety lenses from Armstrong Laboratory (AOC), Brooks AFB, TX 78235-5000, per AFR 160-43.



NVS Aircraft Quantity and Crew Positions

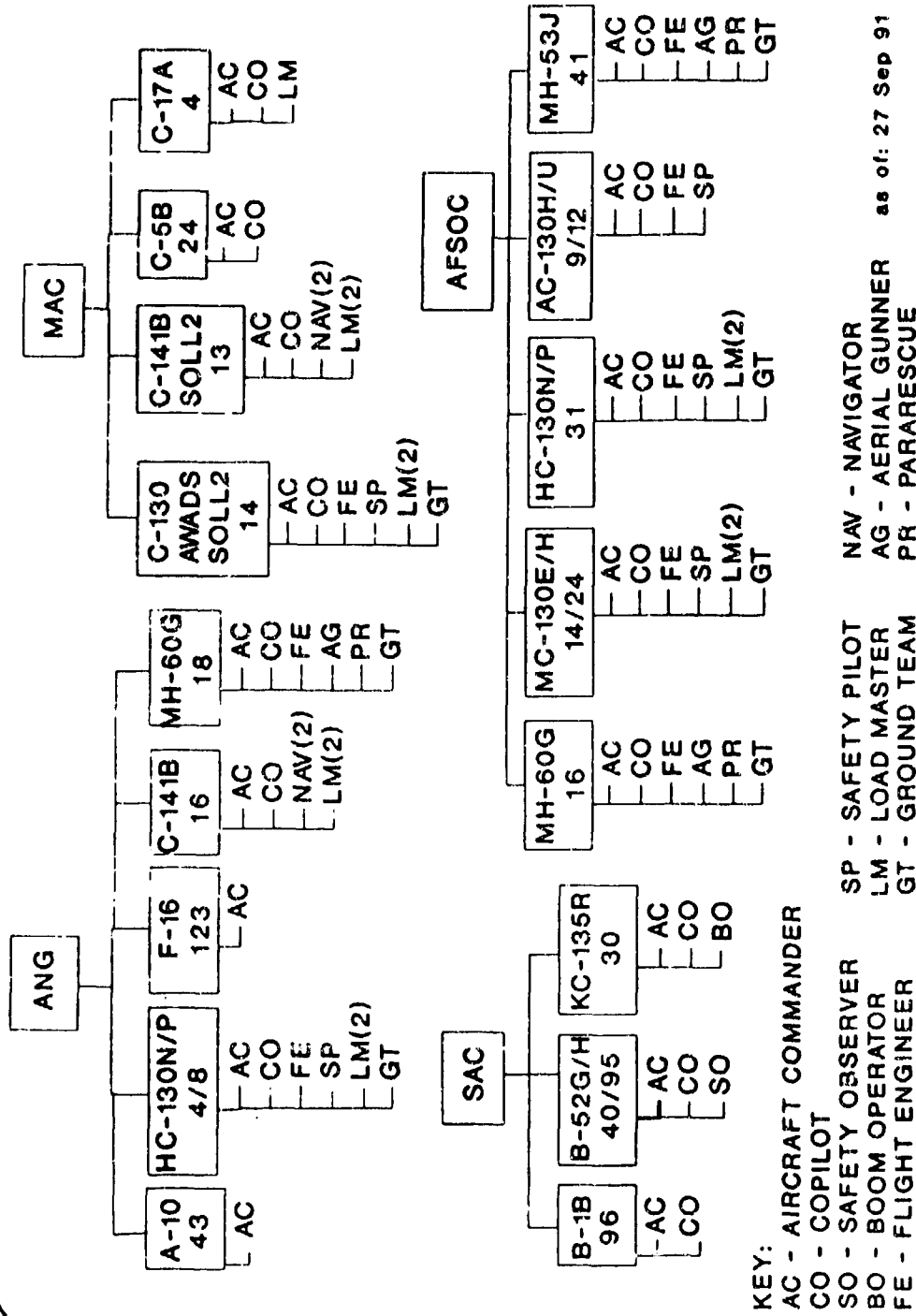

Figure 1-2
USAF aircraft quantity and aircrew positions requiring the use of NVG

CHAPTER 2

NIGHT VISION IN THE UNAIDED EYE

THE EYE

The basic structure of the eye is shown in Figure 2-1. The anterior portion of the eye is essentially a lens system, made up of the cornea and crystalline lens, whose primary purpose is to focus the incident light onto the retina.⁸ The retina contains receptor cells, rods, and cones, which, when stimulated by light, send signals to the brain.⁹ These signals are subsequently interpreted as vision.

Most of the receptors are rods, which are found predominantly in the periphery of the retina, whereas the cones are located mostly in the center and near periphery.¹⁰ Although there are approximately 17 rods for every cone, the cones, concentrated centrally, allow resolution of fine detail and color discrimination. The rods cannot distinguish colors and have poor resolution, but they have a much higher sensitivity to light than the cones.¹¹

PHOTOPIC VERSUS SCOTOPIC VISION

According to the widely accepted duplicity theory of vision, the rods are responsible for vision under very dim levels of illumination (scotopic vision) and the cones function at higher illumination levels (photopic vision).⁸⁻¹¹ Photopic vision provides the capability for seeing color and resolving fine detail (20/20 or better), but it functions only in good illumination. Scotopic vision is of poorer quality; it is limited by reduced resolution (usually 20/200 or less) and provides the ability to discriminate only between shades of black and white.^{9,10} This limitation can be easily confirmed by noting that, at dusk, the different colors of the flowers in a garden become virtually indistinguishable. However, the scotopic system provides enhanced sensitivity and low detection thresholds under markedly reduced illumination.

This dual-receptor system allows the human eye to maintain sensitivity over an impressively large range of ambient light levels (Fig. 2-2).¹¹ Between the limits of maximal photopic vision and minimal scotopic vision, the eye can function rather effectively to changes in brightness of as much as 1,000,000,000 times.¹¹ The sensitivity of the eye automatically adjusts to changes in illumination. The dimmest light in which rods can function is about 10^{-6} millilambert, e.g., 1 millilambert (mL) is essentially the brightness of light from a candle that falls on a surface at a distance of 1 foot¹⁰ and is the rod threshold. This illumination level is equivalent to ambient conditions of an overcast night with no moonlight. The dimmest light in which the cones can function is about 10^{-3} mL, which is the cone threshold⁹ and is roughly equivalent to a night with 50% moonlight. Thus, a white light which can just barely be seen by the rods must be increased in brightness 1,000 times before it becomes visible to the cones. The light intensity of the sun is approximately 30,000 times that of the moon, yet the eye can function well in bright sunlight as well as in dim

moonlight. Although the human eye can function over a vast range of brightness, the retina is sensitive to damage by light, e.g., from lasers or unprotected sun gazing. This potential for light injury exists because the optics of the eye can concentrate light energy on the retina by a factor of 100,000 times.⁸⁻¹¹

MESOPIC VISION

There is a common misconception that the rods are used only at night and the cones only during the day. Actually, both rods and cones function over a wide range of light intensity levels and, at intermediate levels of illumination, they function simultaneously. The transition zone between photopic and scotopic vision, where the level of illumination is equivalent to twilight or dusk, is called mesopic vision (Fig. 2-2).¹² Mesopic vision ranges from about 1 to 10^{-3} mL. Neither the rods nor the cones operate at peak efficiency in this range, but both actively contribute to visual perception. Mesopic vision may be of primary importance to the military aviator at night¹³ because some light is often present during night operations, e.g., flares, afterburners, muzzie flashes, bombs, etc. The brightness output from NVG also falls within this range. Below the intensity of moonlight (10^{-3} mL), the cones cease to function and the rods alone are responsible for what is pure scotopic vision.

DARK ADAPTATION

Dark adaptation is an independent process during which each eye adjusts from a high-luminance setting to a low-luminance setting. The exact mechanisms are unclear, but they are known to include biochemical, physical, and neuronal aspects.¹¹

Both rods and cones contain light-sensitive chemicals called photopigments. The photopigment in the rods is called rhodopsin, or visual purple, which consists of vitamin A and opsin. There are three different types of cone photopigments (red-, blue-, and green-sensitive) that are composed of opsins only slightly different from rhodopsin.^{8,10} Upon exposure to light, photopigments undergo a chemical reaction that converts light energy to electrical activity, initiating visual impulses in the retina that are conducted by nerve fibers from the eyes to the brain.⁸ The initial chemical reaction is called light adaptation and, in this process, the photopigments are decomposed.¹¹ Intense light will decompose the photoreceptor pigments rapidly and completely, thus reducing retinal sensitivity to dim light. Regeneration of the photopigments occurs during dark adaptation.

The fully dark-adapted eye, in which photopigment regeneration is complete, restores retinal sensitivity to its maximal level. Rods and cones differ markedly, however, in their rate of dark adaptation. Cones attain maximum sensitivity in 5-7 min, while rods require 30-45 min or longer of absolute darkness to attain maximum sensitivity after exposure to bright light.⁸⁻¹¹

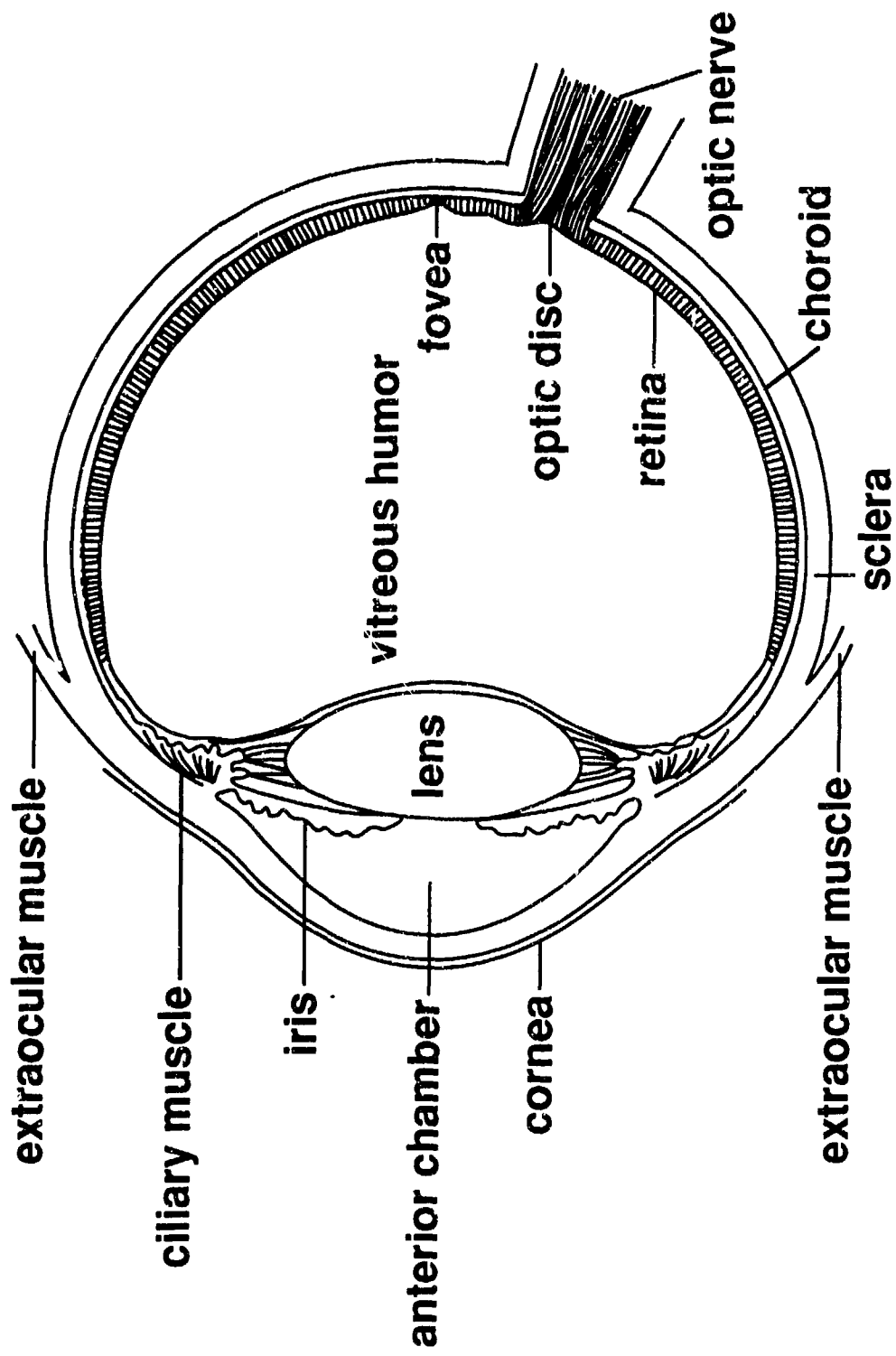

Figure 2-1
Schematic diagram of the eye

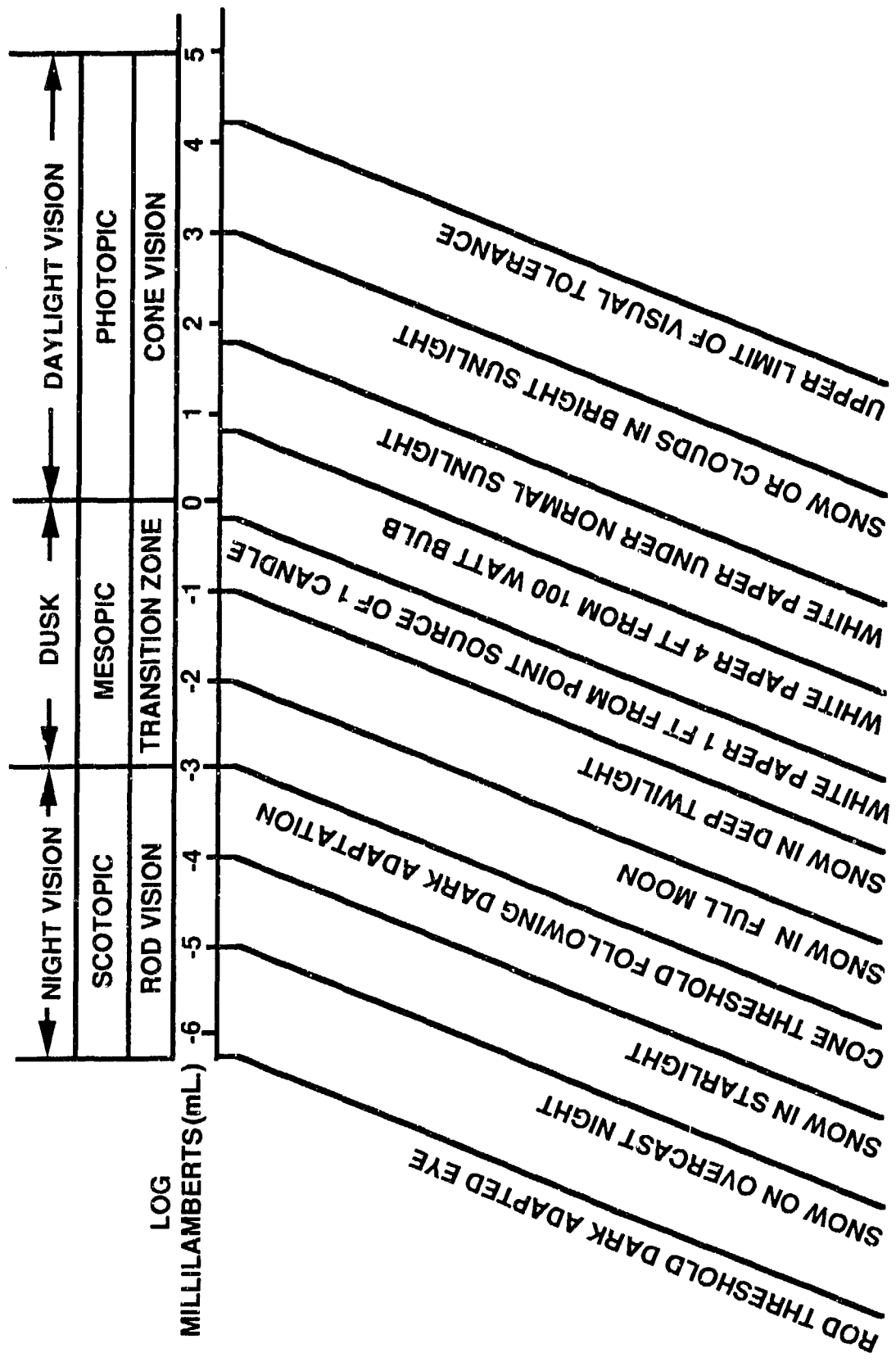

Figure 2-2
 Brightness range over which the human eye can adequately function

The time course of dark adaptation after exposure to bright light is illustrated in Figure 2-3. Retinal sensitivity is very low when darkness is first encountered, but the sensitivity increases 10 times within 1 min; i.e., the retina can respond to light of 1/10th intensity.¹¹ After 20 min, sensitivity has increased 6,000 times, and after 40 min, sensitivity has increased 25,000 times. The plot of this increasing sensitivity is called the dark adaptation curve; it is biphasic and asymptotic.⁸⁻¹¹ The early portion of the curve is caused by the rapid adaptation of the cones, which have a faster rate of photochemical regeneration. The cones, however, do not achieve the same level of sensitivity as the rods. The later portion of the curve shows that the rods slowly adapt, but eventually achieve a much greater sensitivity than the cones. Depending upon the preadaptation to light (i.e., retinal status), dark adaptation is about 80% complete within 30 min, but it may take hours, or even days, to acquire total dark adaptation.^{14,15}

In addition to adaptation caused by changes in photopigment concentrations, the eye has other mechanisms for adapting to changing light conditions. Retinal adaptation can be affected by physical changes in the size of the pupil. The amount of light entering the eye is proportional to the area of the pupil, i.e., the square of the pupillary radius. The diameter of the pupil can contract to 1.5 mm and expand to 8 mm, which equates to a 30-fold range in the quantity of light entering the eye.^{9,10}

Another light-adaptive mechanism is neural adaptation, which is mediated by retinal neurons at successive stages of the visual chain in the retina. When light intensity first decreases, the intensities of the signals transmitted by the retinal neurons are very low. However, the intensities of these signals increase rapidly over time. This change in "neural gain" occurs in seconds and can improve night vision by a factor of 10 or more.⁹⁻¹¹ Neural adaptation is rather like having low-speed and high-speed film simultaneously available in your camera. Furthermore, a large share of the inherently greater sensitivity of rod dark adaptation is a result of retinal summation. As many as 100 rods, or more, converge onto a single ganglion cell (nerve fiber) in the retina, which greatly increases sensitivity.⁸⁻¹¹ Thus, if the rods are slightly stimulated, the summation of several low-level stimuli might be enough to initiate a light signal to the brain. Unlike the photoreceptor chemical changes, these mechanisms occur instantaneously.

CENTRAL BLIND SPOT AT NIGHT

That portion of the retina responsible for the keenest visual acuity (VA) is the fovea, which corresponds to the center of the visual field.⁸ The foveola, or center of the fovea, possesses a high density of cones, but it is completely devoid of rods (Fig. 2-4). Thus, if the ambient light is below cone threshold, when any small object is fixated centrally, it cannot be seen because, at luminance levels below 10^{-3} mL or dim starlight, a blind spot exists in the central 1 degree (deg) of the visual field (Fig. 2-5). This central blind spot corresponds to the foveola, which is rod-free; it cannot function in diminished illumination.

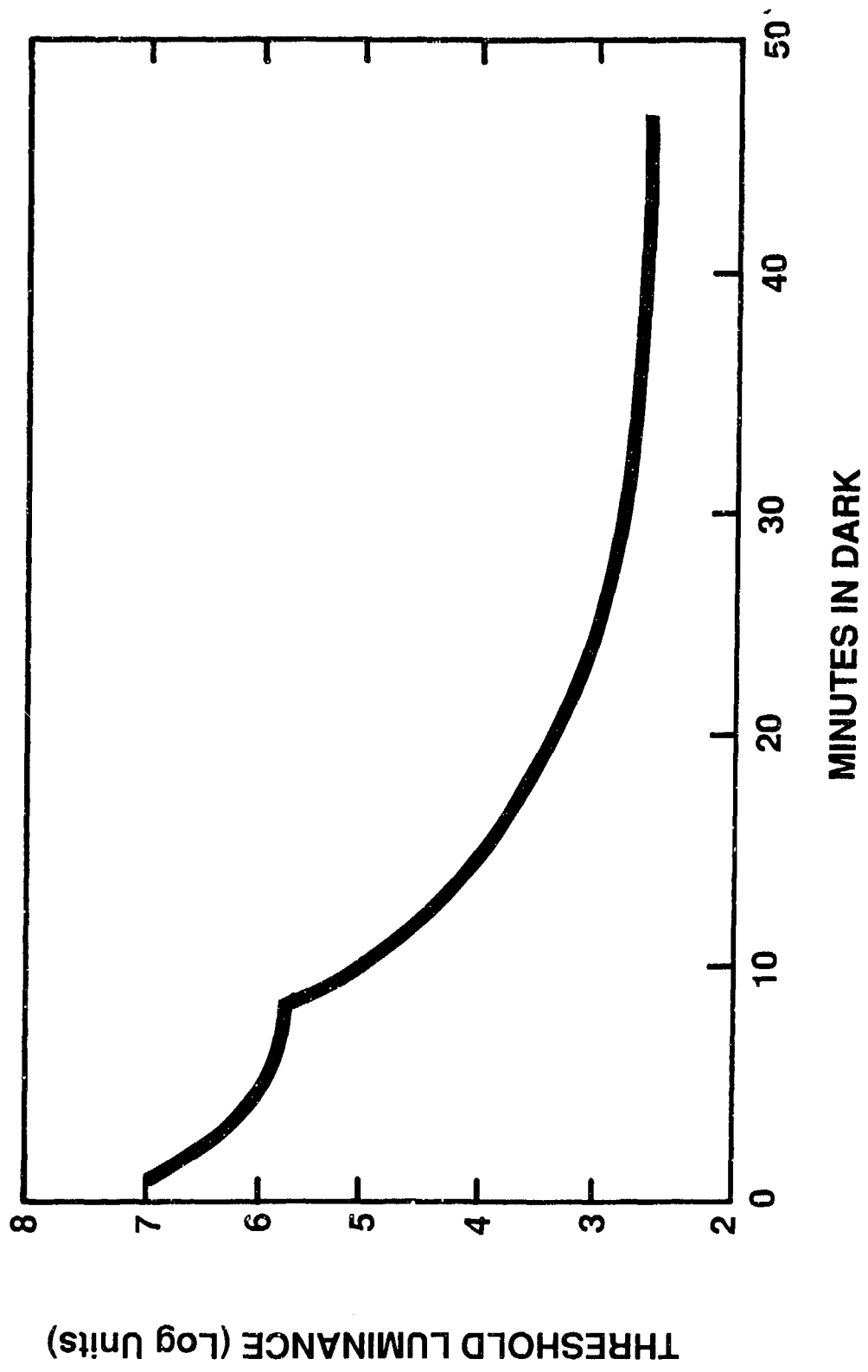

Figure 2-3
Dark adaptation curve

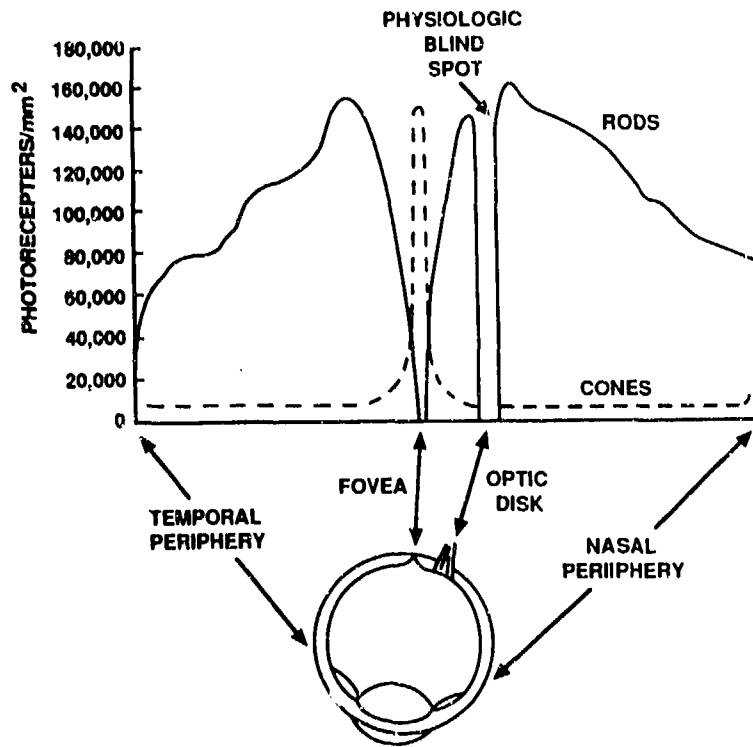

Figure 2-4
 Distribution of rods and cones for the right eye as seen from above. Note the complete absence of cones in the fovea and the high density of rods in the midperiphery.

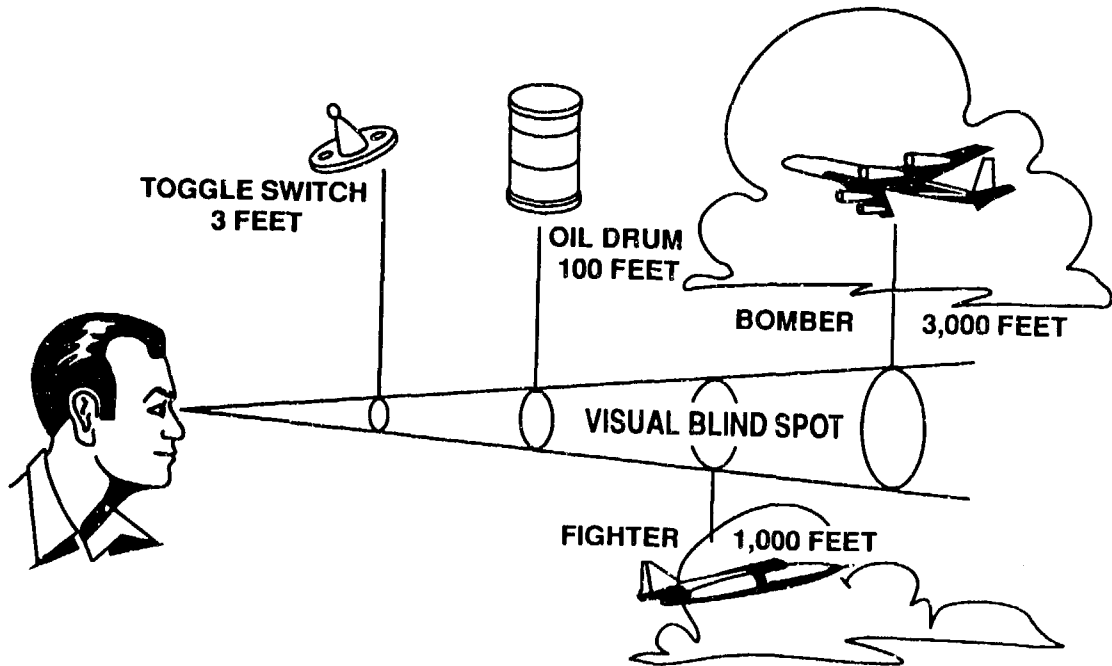

Figure 2-5
 Central 1-degree blind spot at night. Objects that may not be seen at night if central fixation is used.

Each eye also has a physiologic blind spot (Fig. 2-6). Unlike the central blind spot that is only present in low light, the physiologic blind spot is always present.¹³ It is caused by the position of the optic nerve at the rear of the globe. The optic nerve is the confluence of retinal axons leaving the eye. There are no retinal receptors overlying the optic nerve. Fortunately, the physiologic blind spots occur in a different position in each eye. Thus, when both eyes are open, the physiologic blind spots are not apparent.



Figure 2-6
Physiologic blind spot demonstration

Rods are present outside the central 1-deg foveolar area.¹⁶ The rods increase gradually with eccentricity from the foveola, and finally reach a maximum concentration at a point some 17 deg from the fovea (Fig. 2-4). Since the rods have a lower threshold than the cones, they are much more sensitive to light. A person attempting to see in scotopic illumination, i.e., light dimmer than moonlight, has to depend entirely on rods. To best detect small targets with the rods under such circumstances, the individual must look approximately 15-20 deg to one side, above, or below an object to place the object of regard on the part of the retina that possesses the highest density of rods. Individuals can be taught to fixate to one side of an object to avoid the central blind spot and to scan, utilizing the most sensitive part of the retina to improve target detection at night. Therefore, proper education and training are helpful in maximizing visual function at night.

SPECTRAL SENSITIVITY

That part of the electromagnetic energy spectrum which stimulates the photoreceptors in the retina is known as visible light.¹⁷ Visible light includes violet, indigo, blue, green, yellow, orange, and red, i.e., a range of wavelengths extending from about 380 nm (nanometer = 1×10^{-9} meters) to 760 nm (Fig. 2-7). Adjacent portions of the spectrum, although not visible, can affect the eye. Ultraviolet wavelengths extend from 180 nm to 380 nm. Exposure of the eyes to ultraviolet radiation can produce ocular tissue damage. Acute overexposure can cause photokeratitis, commonly called snow blindness, while chronic exposure has been implicated as a possible cause of cortical cataracts. Infrared (IR) wavelengths occur from 760 nm up to the microwave portion of the spectrum. Infrared, or thermal radiation, can also damage ocular tissue (e.g., IR lasers can exfoliate the lens capsule or cause retinal damage.). However, IR does not contain as much photic energy as the shorter wavelength ultraviolet. Most night vision devices are sensitive to portions of the IR spectrum.

Rods and cones are not equally sensitive to visible wavelengths of light. Unlike the cones, rods are more sensitive to blue light and are not sensitive to wavelengths greater than about 640 nm, the red portion of the visible spectrum.

PURKINJE SHIFT

The Purkinje shift (or phenomenon) is the relatively greater brightness of blue or green light, compared with yellow or red light, upon shifting from photopic to scotopic adaptation. For example, in a darkened room, if one looks at two dim lights of equal illumination (one red and one green) that are positioned closely together, the red light will look brighter than the green light when the eyes are fixating centrally. If one then looks to the side of the dim lights about 15-20 deg (i.e., fixates eccentrically), the green light will appear brighter than the red. This phenomenon occurs as the relative luminosity curve (Fig. 2-8) shifts toward the shorter wavelength during transition from photopic to scotopic vision. Central fixation involves cones and photopic vision, while fixating eccentrically involves rods and scotopic vision. The luminosity curve shows that cones are more sensitive to yellow and red, but rods are more sensitive to blue and green. The most sensitive wavelength for cones is 555 nm (yellow-green).¹⁶ That is why the "optic yellow" tennis and golf balls are, in fact, easier to see under photopic conditions. The most sensitive wavelength for rods is 505 nm (blue-green). Thus, blue-green lights will generally look brighter at night than red lights. The sensitivity of the eye changes from the red end of the visible spectrum toward the blue end when shifting from photopic to scotopic vision.

PHOTOCHROMATIC INTERVAL

An appropriate demonstration of the difference between photopic and scotopic sensitivity is to slowly decrease the intensity of a colored light until the cone threshold is reached. This is the point at which the color will disappear, but not the sensation of light. When this procedure is performed with any color except red, e.g., blue light, the color will disappear at the cone threshold, but the light will still be perceived

by the rods as dim gray. If the intensity is further decreased until the rod threshold is reached, the light will disappear entirely. With red light, the color and sensation of light disappear at the same time.

The difference between the level of illumination at which the color of a light disappears (the cone threshold) and that at which the light itself disappears (the rod threshold) is known as the photochromatic interval. There is a photochromatic interval for every color of the spectrum, except the longer red wavelengths.¹⁷

NIGHT BLINDNESS

True night blindness is unusual.¹⁵ Night blindness can be caused by long-term vitamin A deficiency such as may occur from chronic starvation (e.g., prisoners of war), alcoholism, deficient fat absorption, and diseases of the liver. Retinal conditions that may cause night blindness are glaucoma, progressive cone/rod dystrophies (e.g., retinitis pigmentosa, Stargardt's disease), drug toxicity (e.g., chloroquine retinopathy), fundus flavimaculatus, and congenital stationary night blindness. Although not true night blindness, night myopia may also reduce night vision; it will be discussed in the next chapter. Considerable individual variability exists in retinal sensitivity to light among normals.¹⁸ Also, there is a strong inverse correlation between night vision and age.¹⁹

TESTS OF NIGHT VISION

Special instrumentation is necessary to adequately test retinal sensitivity. Unfortunately, there is no simple, easy screening test for the Armed Forces to quantify or measure night visual function. On the flight physical examination, only a positive or negative history of night vision problems is recorded. It would be nice to be able to screen the night vision of all USAF personnel and classify individuals on the basis of their night vision capabilities. Thus, critical night missions could be performed by personnel with the best night vision, and those individuals could be monitored to ensure that adequate levels of night vision were maintained. However, vision at night in the operational world is a complex process and cannot be assessed by just one single test. In fact, photopic and scotopic sensitivity, dark adaptation, mesopic vision, spatial contrast sensitivity, dark focus of accommodation, peripheral visual fields, glare sensitivity, and glare recovery are all important factors in military operations at night.²⁰ It would be too time consuming, expensive, and difficult to test for all of these parameters.

A state-of-the-art electrophysiologic and psychophysiologic laboratory, such as the one at the Aeromedical Consultation Service, Ophthalmology Branch, Armstrong Laboratory, Brooks AFB, Texas, is required to be able to adequately test clinical night visual function. The battery of tests available includes dark adaptometry, electroretinography, electro-oculography, visual-evoked response, contrast sensitivity, and mesopic glare acuity. The time required to run an appropriate battery of tests on one patient is at least 4 hours. Expert professional and technical support is needed to set up, calibrate, maintain, and operate these instruments and interpret the results.

THE ELECTROMAGNETIC SPECTRUM

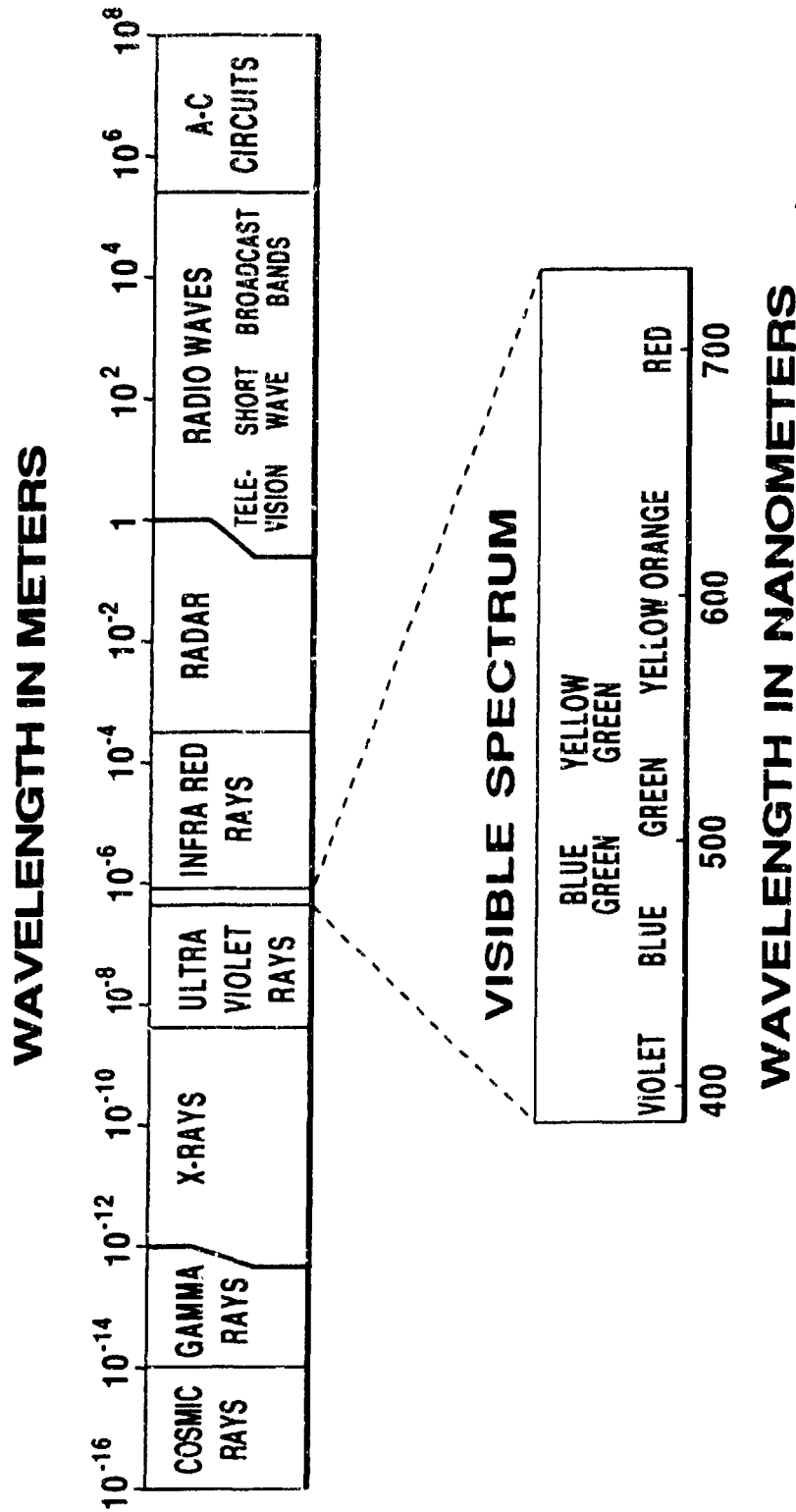
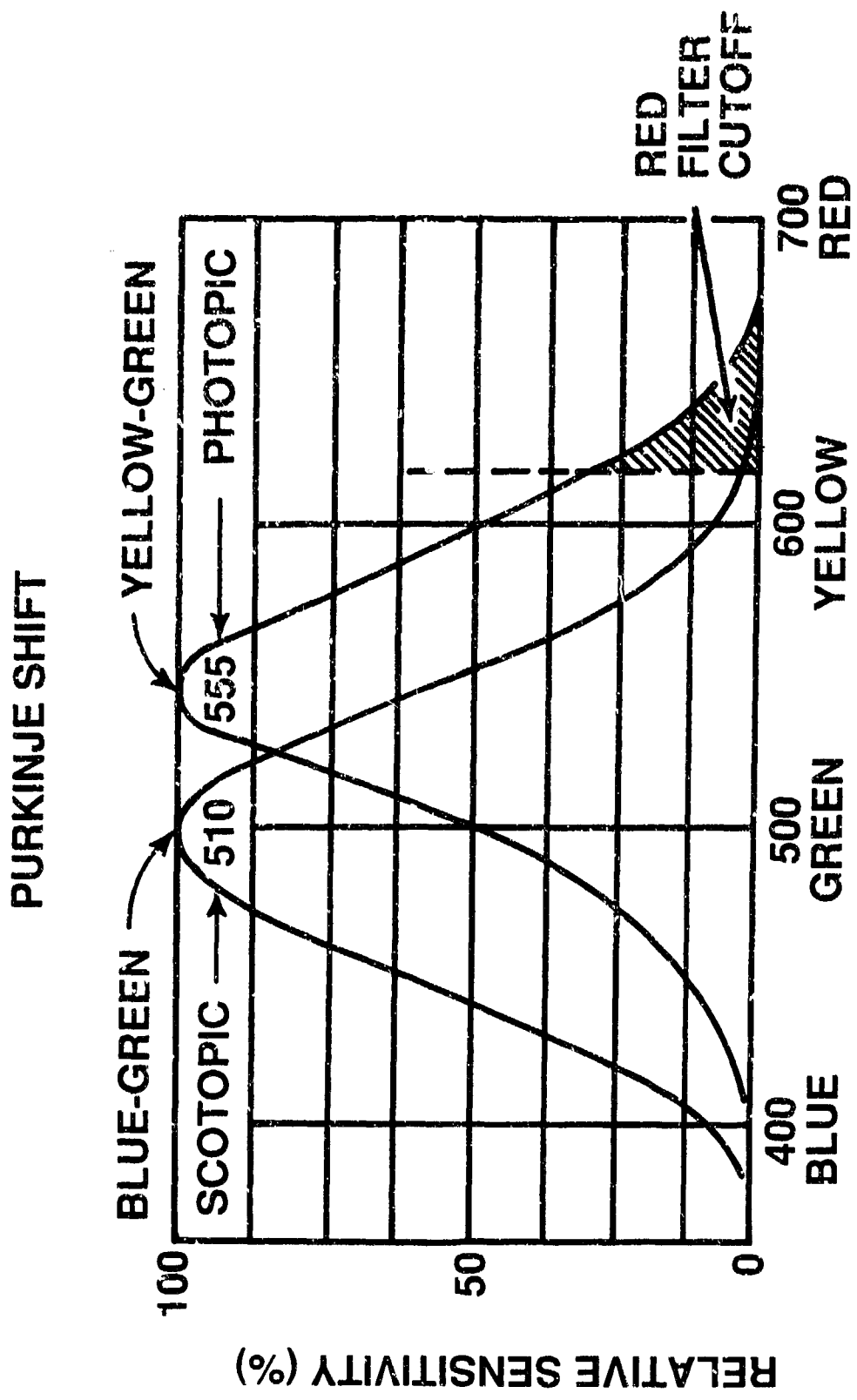

Figure 2-7
Visible portion of the radiant energy spectrum



WAVE LENGTH IN NANOMETERS

Figure 2-8
Luminosity curves for scotopic (rod) and photopic (cone) vision (Purkinje shift)

Flight surgeons should directly question individual aircrew members during physical examinations about any personal or family history of night vision problems. Practically speaking, an aircrew member complaining of night vision problems should first be examined by an optometrist to rule out refractive error, night myopia, or ocular pathology. Subjective night vision problems can often be cured by correcting small amounts of myopia. On the other hand, some aircrew members may be found to have serious retinal pathology; these aviators may require referral to an ophthalmologist. Referral to an ophthalmologist is also required if the clinical eye examination by an optometrist fails to find the problem. Any condition that may permanently ground a flyer warrants referral to the Aeromedical Consultation Service, Ophthalmology Branch, Armstrong Laboratory, Brooks AFB, Texas.

CHAPTER 3

OPERATIONAL ASPECTS OF NIGHT VISION

INTRODUCTION

The effects of decreased illumination on operational visual function can be dramatic. As discussed in Chapter 2, visual acuity (VA) may be reduced to 20/200 or less, color vision is lost, blue-green lights will appear brighter while red lights will appear dimmer, problems may occur with night myopia, depth perception is degraded, glare is a factor, and a central blind spot is present. The potential effects of these factors on the operational aspects of night vision will now be considered.

CONTRAST DISCRIMINATION

VA is reduced at night under low illumination, and 20/20 vision cannot be sustained below a level of about 1 mL, i.e., in the low photopic or upper mesopic range.¹⁶ Objects can be seen at night only if they are either lighter or darker than their background and can be discriminated by subtle differences in contrast. Because VA at night is a function of small differences in the luminance contrast between objects and their background, any transparent medium through which the flyer must look should be kept spotlessly clean. Contrast discrimination may be reduced by light reflected from windshields, visors, spectacles, fog, or haze.

Knowledge of the importance of contrast at night was used by pilots during World War II to detect enemy planes, as well as to hide their own positions. Pilots would fly below the enemy when passing over dark areas, such as land, or when flying over an area illuminated by multiple points of light, such as a large city at night.¹⁷ Conversely, they would fly above the enemy when passing over white clouds, desert, moonlit water, or snow. Following another aircraft from above or below, rather than from directly behind, will maintain the largest retinal image and lessen the likelihood of losing sight of the other aircraft in the darkness.

NIGHT MYOPIA

Flyers who do not normally wear spectacles, or those who wear visual correction, may have a small myopic shift under extremely reduced illumination.²¹ The exact cause of this so-called night myopia, although controversial, suggests two components--ocular spherical aberration (Fig. 3-1) produced by the widely dilated pupils, and slight to moderate involuntary ocular accommodation. This myopic shift, or posture of involuntary accommodation, is called the dark focus. The dark focus posture of accommodation may become a problem whenever there is a lack of adequate distance objects upon which to focus. Although dark focus effects vary, it has been reported that some people have 0.75 diopter (D) or more of a myopic shift. A diopter

refers to the power of a lens, or ocular accommodation; it is the reciprocal in meters of the focal length of a lens. However, the concept that a myopic dark focus poses a real operational problem is controversial. For most people, night myopia has a relatively minor effect because no visually resolvable distant target is present when it occurs. When a target does become visible, the eye rapidly readjusts. Since night myopia does not occur in the cockpit when the crew is operating under photopic conditions, it is probably more of a theoretical concern.

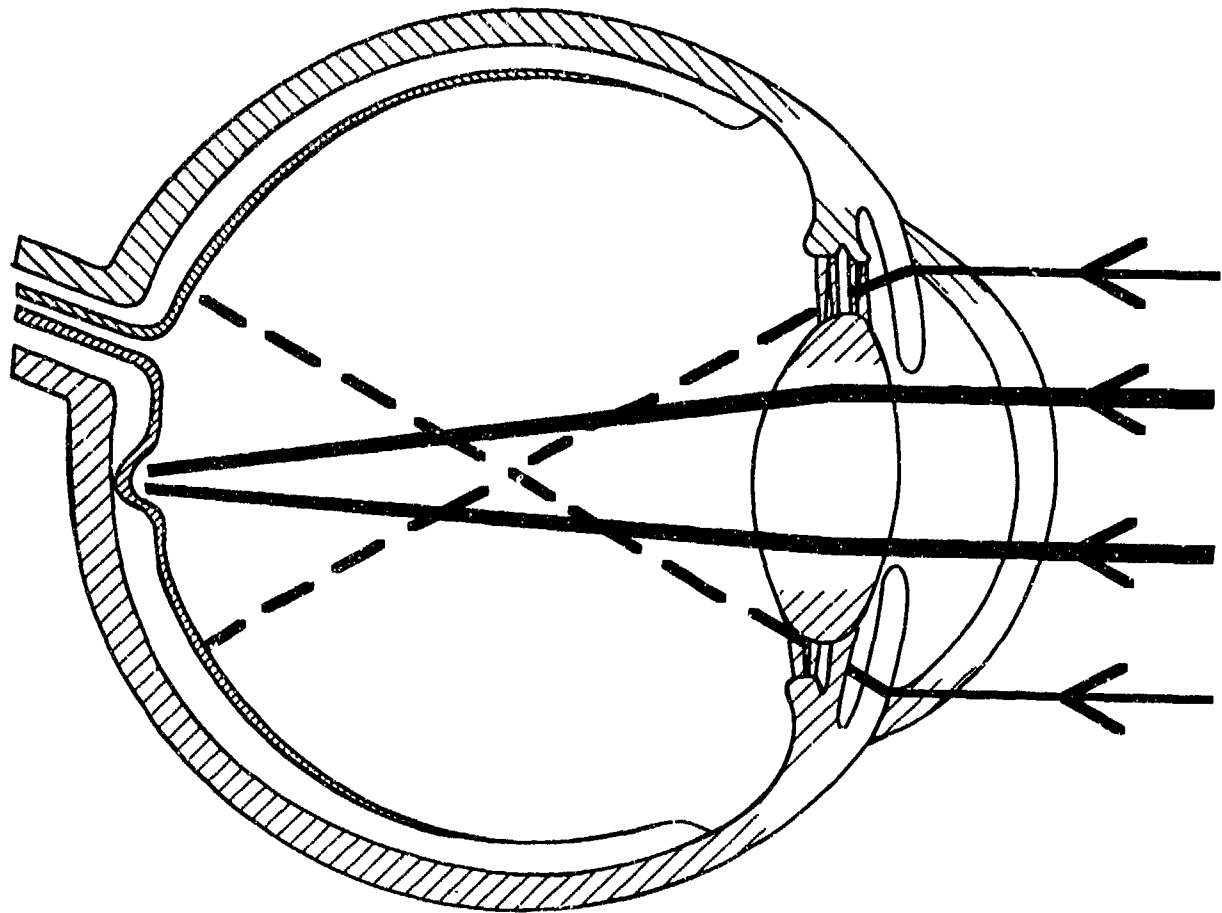

Figure 3-1
Ocular spherical aberration

ENHANCING AND MAINTAINING DARK ADAPTATION

Red Goggles

For maximum utilization of scotopic vision, 20 to 30 min in total darkness are required to attain satisfactory retinal dark adaptation. An alternative is to have the aircrew member wear red goggles for 20-30 min before flying.²² When worn in normal illumination, red goggles will not interfere significantly with the ability to read most maps, charts, manuals, etc., as long as the printing is not in red ink. Red goggles block all light except red, which enhances rod dark adaptation because red light does not stimulate the scotopic system.

To understand why red filters or red lighting can be used to achieve dark adaptation, one must examine the relative positions of the photopic and scotopic sensitivity curves in Figure 2-8. If a red filter is worn that has a cutoff of about 650 nm, i.e., the transmission of all light below 650 nm is eliminated, essentially no light is transmitted that can stimulate the rods. Thus, by wearing red goggles for 30 min, the rods become almost fully dark-adapted. The cones, however, are moderately sensitive to the red light and adequate VA is permitted through the goggles. Although the cones are not dark-adapted, they adapt in 5 to 7 min after one steps into the dark. Also, cone adaptation is less important at night than rod adaptation, since the cones are incapable of functioning in starlight illumination. However, there are some drawbacks to wearing red goggles. For example, when reading maps, markings in red on a white background may be invisible. Red light also creates or worsens near-point blur in older hyperopic (far-sighted), presbyopic (reduced accommodative ability due to age), and pre-presbyopic aircrew.²³ In this condition, due to ocular chromatic aberration (inability to focus all colors at the same plane; Fig. 3-2) red light is focused behind the retina and requires the eye to accommodate more to bring a red image into focus (Fig. 3-3).

Flash Blindness

While dark adaptation of the rods develops rather slowly over a period of 20 to 30 min, it can be lost in a few seconds of exposure to bright light. Accordingly, during night operations aircrew members should be taught to avoid bright lights, or, at least, protect one eye. Dark adaptation is an independent process in each eye. Even though a bright light may shine into one eye, the other eye will retain its dark adaptation if it is protected from the light.²⁴ This is a useful bit of information, because a flyer can prevent flash blindness and preserve dark adaptation in one eye by simply closing or covering it. The instrument panel should be kept illuminated at the lowest level consistent with safe operation, and the flyer should avoid looking at flares, afterburner flames, or gun flashes to avoid temporary flash blindness. If light must be used, it should be as dim as possible and should only be used for the shortest possible period.

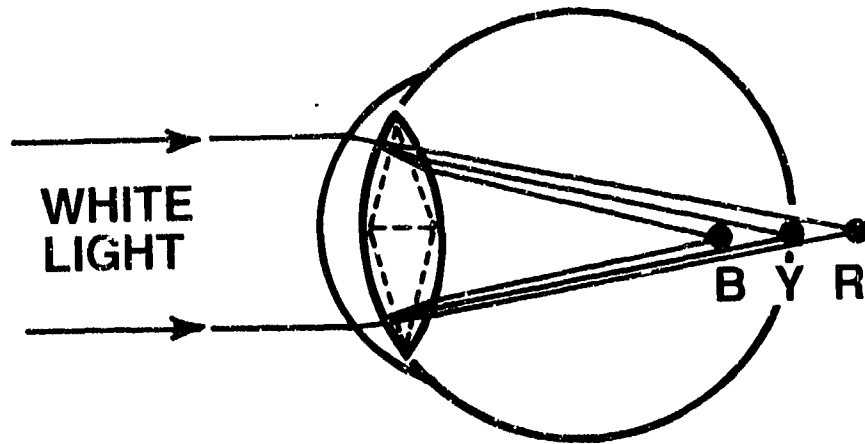

Chromatic aberration of the eye-distance object

Figure 3-2
Ocular chromatic aberration--distance object

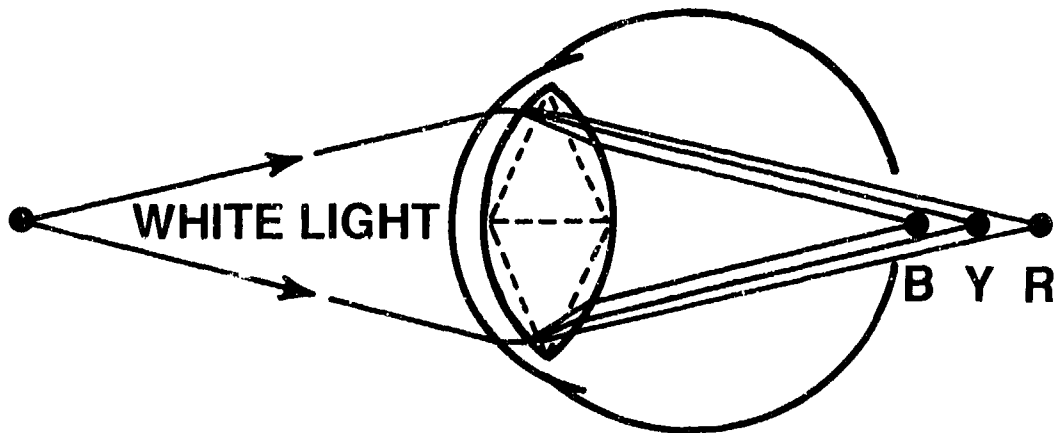

Chromatic aberration of the eye-near object

Figure 3-3
Ocular chromatic aberration--near object

Daytime Exposure

Daytime exposure to ordinary sunlight can produce temporary but cumulative aftereffects on dark adaptation and night vision. Both civilian and military studies have documented significantly diminished rod performance after prolonged sunlight exposure at, for example, the beach or ski slope.^{19,20,25} Two or three hours of bright sunlight exposure has been shown to delay the onset of rod dark adaptation by 10 min or more, and to decrease the final threshold, so that full night vision sensitivity could not be reached for hours. After 10 consecutive days of sunlight exposure, the losses in night vision sensitivity were reported to cause a 50% loss of visual acuity, visibility range, and contrast discrimination. Repeated daily exposures to sunlight prolong the time to reach normal scotopic sensitivity, so that eventually normal rod sensitivity may not be reached, even overnight.

There are several means for providing eye protection during the day and conserving night vision. First, aircrew members should remain inside during the day of a night mission, if at all possible. Sleeping during the day in a darkened room is highly recommended. While outside, aircrew members should wear their aircrew sunglasses and a hat with a brim, which will block a great deal of the ambient solar radiation. Dark sunglasses that transmit only 10-16% of the visible light will prevent degradation of night vision.²⁶ In general, one day of protection from sunlight exposure was usually sufficient to recover normal night vision sensitivity. However, in certain individuals, it may take days to weeks to recover full night vision capability.

For sunglasses to be effective, all visible light has to be attenuated, not just portions of the visible spectrum. Thus, colored or yellow visors and spectacles are not protective. To protect night vision, provide the best comfort, allow for scanning close to the sun, and provide normal color vision, dark sunglasses with a neutral gray tint have been recommended. Tinted sunglasses that are too dark may reduce VA unless the ambient brightness remains excessively high. Lighter sunglasses may not be dark enough to protect retinal sensitivity for night vision. Therefore, it has long been recognized that military flyers should be required to use sunglasses on sunny days.^{25,26} These sunglasses should have a visible luminance transmission of 15% or less. The standard USAF aviation sunglasses will provide adequate protection for night vision, if they are worn religiously when the flyers are outdoors in bright sunlight.¹⁶ Anyone who is unusually sensitive should remain indoors during the afternoon before a night mission. Pilots should ensure that they wear sunglasses or sunvisors when flying on sunny days. In addition to aviators' night vision, the night vision of other personnel, i.e., security guards, sentries, ground defense personnel, air defense forces, etc., should also be protected.

COCKPIT ILLUMINATION

Red light (wavelength >650 nm) was used for illumination of the cockpit in post-World War II (WW II) aircraft because it, like red goggles, did not degrade dark adaptation.²⁷ The intent was to maintain the greatest rod sensitivity possible, while still providing some illumination for central foveal vision. However, red cockpit lights interfered with reading maps and log books, especially for pre-presbyopic and presbyopic

aviators.¹⁹ With the increased use of electronic and electro-optical devices for navigation, target detection, and night vision, the importance of the pilot's visual efficiency in the cockpit has increased and new concerns have arisen.

Low intensity, white cockpit lights are often used now because they afford a more natural visual environment within the aircraft, without degrading the color of objects. Special blue-green cockpit lights are employed in aircraft in which third-generation (III-Gen) night vision goggles are used because, unlike the human eye, these devices are not sensitive to light at the blue end of the visual spectrum.²⁸ Some additional benefits of blue lights are that rods are more sensitive to blue light and, due to ocular chromatic aberration (Fig. 3-3), it is the best choice for near vision and accommodative focus. Under scotopic conditions, however, the enemy can see a blue light at a greater distance, whereas a low intensity red light would be nearly invisible (Fig. 2-8).

VISUAL ILLUSIONS AT NIGHT

Reduced visual references, due to low ambient light levels, can lead to several types of visual illusions that may cause spatial disorientation.^{16,29,30} There are two forms of visual processing,¹³ central (focal) and peripheral (ambient). Whereas central vision is predominantly concerned with object recognition and discrimination, peripheral vision provides motion detection and spatial orientation information. At night, under reduced illumination levels, the normal peripheral vision cues may be degraded or absent, and spatial disorientation may be more difficult to overcome. Spatial disorientation may arise from labyrinthine, proprioceptive, or visual mechanisms.

Autokinetic Effect

Autokinesis, or the autokinetic effect, is the phenomenon of perceived movement exhibited by a static dim light when it is stared at in the dark.^{16,17} This effect can be demonstrated by staring at a lighted cigarette in a dark room. The dim light will appear to move about, even though it is stationary. Although the exact cause of this illusion is not known, it is related to microfixational movements of the eye and the loss of surrounding references which normally stabilize visual perception. This illusion will also occur when there are two dim lights in darkness, but it normally disappears when three or more lights are present. Pilots on night missions have mistaken stars or ground lights for other aircraft and have become disoriented, with fatal consequences. Therefore, pilots should be aware of this visual illusion. The autokinetic effect can be reduced by maintaining good visual scanning techniques rather than staring at the light source, or by increasing the intensity of the lights, if that is possible.

Black Hole Illusion

The black hole illusion may occur on a dark night over water or unlighted terrain where the horizon is not easily discernible.^{17,25} The worst case occurs when there are no visual references except for runway lights. Without peripheral visual cues for

orientation, the pilot tends to perceive that his aircraft is stable, but that the runway itself is malpositioned, usually downsloping. The black hole illusion makes the landing approach dangerous, and often results in a landing far short of the runway. A particularly hazardous type of black hole approach occurs when the earth appears to be totally dark except for the runway and the lights of a city on rising terrain beyond the runway. By maintaining a constant vertical visual angle on the distant city lights, the pilots approach may fall below the intended glideslope as the aircraft gets closer to the runway.

Distance Illusion Phenomenon

The distance illusion phenomenon (DIP) is a dangerous illusion that can occur when one aircraft is trailing another in a black hole environment with few peripheral vision cues.²⁵ A likely scenario for the DIP occurs when the trailing aircraft pilot, for position reference, places the image of the lead aircraft on a certain spot in his canopy or HUD (head-up display) combiner lens. The pilot orients the lead aircraft in exactly the same spot on the canopy or HUD, but, over time, inadvertently falls back to a greater separation distance. If the trailing aircraft started out 2 nautical miles behind and 300 ft below the lead aircraft and then fell back to 4 nautical miles, that would mean that the trailing aircraft was now 600 ft below the lead. If the lead aircraft gradually descends to 600 ft or less, the trailing aircraft may impact the ground. The potential mishap exists only if the pilot maintains the lead aircraft in exactly the same spot on the canopy or HUD, but fails to monitor the actual altitude or fails to realize that the separation distance has increased.

False Perceptions

Pilots are especially susceptible to misperception of the horizon while flying at night. To a pilot, isolated ground lights can look like stars and create the false impression of a nose-high pitch or wing-low attitude. If no stars are visible because of overcast conditions, unlighted areas of terrain may blend with the dark overcast to create the illusion that the unlighted terrain is part of the sky. An extremely hazardous takeoff occurs over an ocean or other body of water that cannot be distinguished visually from the night sky; pilots who have falsely perceived that the shoreline receding beneath them was the horizon have met with disastrous consequences.^{3,25}

At night, if runway lights viewed from an approaching aircraft are displaced laterally, the pilot may have the impression that the runway is closer than it really is, because it appears wider. This false perception may result in an early flare and a tendency to land short.¹⁶ Also, the intensity of runway lights may appear to vary, depending upon their color and the adaptation states of the eyes. These differences in the brightness of runway lights may lead to false perceptions regarding altitude.

Pilots are aware of certain vestibular illusions that may be more difficult to overcome during nighttime operations.¹⁷ Somatogravic illusions are false perceptions of the body's orientation to gravity. Somatogyral illusions are experienced by pilots

during maneuvers of sustained angular motion such as coordinated turns, spins, or rolls. These illusions result from the inability of the semicircular canals of the inner ear to register sustained angular velocity. The lack of visual cues at night may make these illusions more troublesome.

DRUGS

The use of systemic drugs to improve night vision in healthy individuals has been uniformly unsuccessful.³¹ Night blindness can occur from vitamin A-deficient diets, but this is uncommon and will only occur after several weeks or months of severe dietary deficiency. Large quantities of vitamin A are normally stored in the liver and are readily available to the rest of the body in times of need. This type of night blindness can be cured quickly by intravenous injection and/or megadoses of vitamin A. Vitamin A has improved night vision only when there has been a chronic insufficiency of the vitamin and the stores in the liver were depleted. Excess vitamin A, taken as a dietary supplement, has not been shown to improve night vision in normal, healthy subjects.

During World War II, British Royal Air Force pilots were given a breakfast jam made from bilberries that reportedly improved their night vision. Since that time, sporadic reports have surfaced that propose that the bilberry extract is a night vision enhancer.^{14,16} Considerable skepticism exists in the scientific community, however. A definitive evaluation seems warranted.

TOBACCO

The effects of smoking tobacco products on night vision are controversial.³² Early studies showed a significant decrease in scotopic dark adaptation with smoking, which was attributed to the hypoxic effects of carbon monoxide (CO). Later studies found that smoking seemingly improved night visual performance on some psychophysical tests. This improvement was presumed to be a result of the stimulant effect of nicotine. More recent studies have reported that smokers have reduced mesopic vision when compared with nonsmokers. For a listing of references and a review of the literature, see Appendix B.

Although the literature is somewhat confusing, smoking should be discouraged for several reasons. First, there is some evidence that it may degrade mesopic and night vision.¹⁶ Second, although many night missions are low level, the hypoxic effect of CO is additive with altitudinal hypoxia. Third, secondary smoke is a significant irritant for aircrew who wear contact lenses or for those with dry eyes. Fourth, smoke forms filmy deposits on windscreens, visors, and spectacles that can degrade contrast at night. Fifth, the effects of smoking withdrawal during long missions may be dangerous. Finally, the chronic long-term effects of smoking are hazardous to overall health.

HYPOXIA

The effect of altitudinal hypoxia on night vision is primarily one of an elevation of the rod and cone threshold. Although decreased cone function is clearly demonstrated by the loss of color vision at hypoxic altitudes, the decrement in central VA is usually insignificant.¹⁶ However, scotopic night vision at altitude can be significantly reduced. Scotopic vision has been reported to decrease by 5% at 3,500 ft, 20% at 10,000 ft, and 35% at 13,000 ft, if supplemental oxygen is not provided.¹⁷ Thus, the use of oxygen, even at low pressure altitudes, can be very important at night.

NIGHT VISION DEVICES

Currently, several electro-optical devices are available to improve vision at night which include NVG and FLIR systems.

Most NVG systems are helmet-mounted and look like binoculars.²¹ To make objects and landscape visible at night, NVG usually employ two image-intensifier (I²) tubes to amplify or intensify low levels of reflected and emitted ambient light. I² tubes are sensitive to some visible and short wavelength IR radiation, but a minimum amount of ambient light is needed to excite the green phosphor screen and produce visible images.³³ Thus, NVG are great threat detectors because they can detect gun flashes and bullets.⁷

An NVG intensified image resembles a black and white television image, except it is in shades of green instead of shades of gray due to the selected display phosphor. The image that is seen by the aircrew member is not a direct view, but an image displayed on a phosphor screen (Fig. 3-4). The NVG system is analogous to using a microphone, amplifier, and speaker to amplify a faint sound and make it audible. In both cases, some of the "natural fidelity" may be lost in the amplification process. NVG enhance night vision over unaided scotopic vision; however, they do have significant limitations.⁵ The performance limitations include VA of about 20/40 at best, a field of view of 40 deg or less, degraded depth perception, little or no stereopsis, and a different spectral sensitivity than the human eye.^{16,34,35} These limitations reveal that, at times, it may be difficult to distinguish the horizon/terrain line when relying on NVG. Thus, training and experience with NVG are critically important for flying safety. Detailed information about NVG is contained in Chapter 4.

A Forward-Looking Infrared (FLIR) device consists of a cockpit- or helmet-mounted video monitor that displays pictures from an external IR sensor that is usually fixed forward, i.e., slaved to the nose of the airplane.^{7,16,36} However, some FLIR systems are manually slewed or head steered. Infrared sensors, because they are telescopic systems, provide good resolution. These sensors are sensitive to the long wavelength IR (thermal) and provide excellent resolution. Infrared sensors can detect radiation in either the 3,000-5,000 nm or the 8,000-12,000 nm spectral range (Fig. 2-7). An FLIR must have thermal radiation available, but many objects radiate measurable amounts of IR energy in this spectral range. This type of sensor is not dependent on ambient light, but, rather, on temperature differences based on IR radiation generated

by the scene. An important measure of performance of an IR sensor is the minimum temperature difference that the sensor can resolve. This is called the minimum resolvable temperature, which is analogous to NVG resolution based on differences in light levels, i.e., radiance. FLIR devices cannot see bullets fired, but they can see through fog, smoke, brownout, haze, or clouds. Severe weather conditions may be missed when relying on FLIR devices because the clouds cannot be seen.² Many FLIR devices have a smaller field of view than NVG and are slaved to the airplane centerline, with limited capability to look from side to side (Fig. 3-5). Some C-130 aircraft and UH-60, and AH-64 Apache helicopters do have FLIRs with slew capability.

A good example of this technology is the FLIR system used in the U.S. Army's Apache helicopter (AH-64) which incorporates a head-steered FLIR with a helmet-mounted display known as the Integrated Helmet and Display Sighting System (IHADSS).³⁷ This display receives its input from a thermal imaging sensor that is sensitive to spectral radiation in the 8,000-12,000 nm range. The sensor is mounted on the nose of the aircraft. The display, which produces the image of what the sensor "sees," is a miniature (1-in diameter) CRT mounted on the aviator's helmet (Fig. 3-4). The imagery is relayed optically through a series of lens elements and reflected off a beamsplitter into the aviator's right eye. The CRT and relay optics are mounted on the right side of the helmet and provide imagery in a monocular format. The IHADSS display provides a 1-1 representation of the 30-deg (vertical) by 40-deg (horizontal) field of view provided by the sensor.

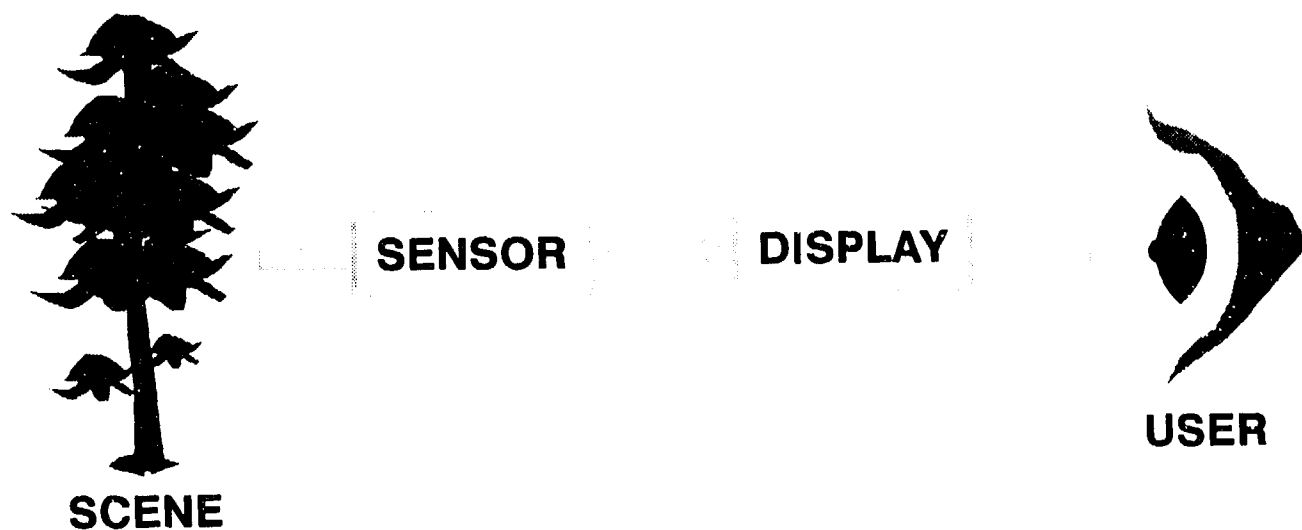

Figure 3-4
Night Vision Device (NVD) block diagram

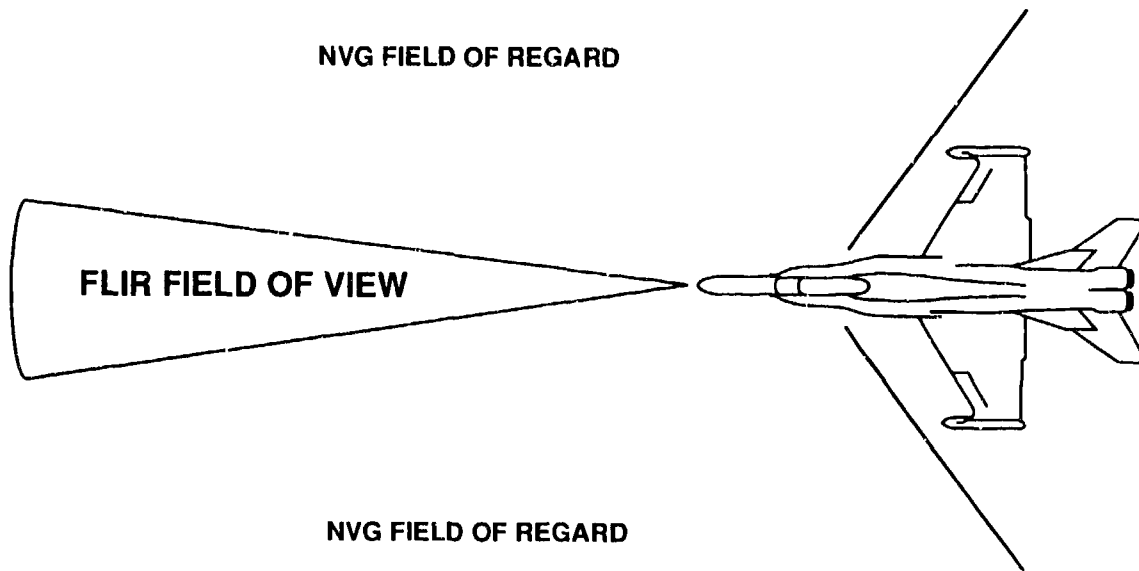

Figure 3-5
FLIR field of view versus NVG field of regard

RECOMMENDATIONS

The following are some ways for aircrew members to protect, improve, or maintain their operational night vision.

- (1) Complete a training course that emphasizes the inherent limitations of night vision.
- (2) Keep spectacles, visors, and windscreens clean.
- (3) Wear the proper spectacle correction.
- (4) When practical, dark-adapt or use red goggles before flying.
- (5) Avoid bright lights, or at least protect one eye.
- (6) Do not fixate centrally, but scan and look 15-20 deg to the side of the visual target.

(7) Regularly wear dark sunglasses (10-16% transmission) on sunny days, especially on days of night missions.

(8) Eat an adequate diet that includes vitamin A.

(9) Do not smoke.

(10) Consider the use of 100% oxygen at night, even at low altitudes.

CHAPTER 4

INTRODUCTION TO NIGHT VISION GOGGLES (NVG)

HISTORY

Image-intensifier (I^2) systems are the modern offspring of the starlight sighting scopes for rifles used by the military after World War II.²¹ I^2 systems, in the form of NVG, were first used by U.S. ground forces in Vietnam. In the early 1970s, NVG were first used by the U.S. Air Force, and later by the U.S. Army, as a temporary aid for helicopter pilots.² The latter use of NVG demonstrated that an image-intensification system could increase the operational capability of helicopters by allowing pilots to fly at higher speeds and lower altitudes during nighttime missions. The successful use of second-generation (II-Gen) I^2 technology in rotary-wing aircraft led the U.S. Army to develop a III-Gen system which was specifically designed for helicopter pilots. The U.S. Air Force currently uses NVG in both helicopters and fixed-wing aircraft.

The British were the first to successfully demonstrate that NVG provided adequate imagery to allow pilots of fighter/attack aircraft to fly low and fast at night.³⁶ Subsequently, U.S. Marine Corps Harrier pilots started using NVG, as did Air National Guard/Air Force Reserve pilots in A-7 aircraft.

ELECTRO-OPTICAL DESIGN

The two predominant types of NVG currently being used by the U.S. Air Force are the AN/PVS-5 (Army and Navy/Personal Vision System), a II-Gen system which was designed for ground personnel, e.g., tanks, jeeps, infantry, etc. (Figs. 4-1a and b), and the III-Gen ANVIS (Aviator's Night Vision Imaging System) (Fig. 4-2). A United Kingdom version called Cats-Eyes (Fig. 4-3) is being used by the U.S. Navy, Marine Corps, and Air National Guard. Similar to binoculars in outward appearance, these electro-optical devices amplify existing light by means of two I^2 tubes. An I^2 tube is an electronic viewing device that amplifies ambient light reflected from an object and presents an intensified image on a phosphor screen. Unlike binoculars, I^2 tubes do not provide direct viewing of objects.³⁷ Instead, the electro-optical system provides a virtual image on a green phosphor display (Fig. 3-4); focusing is accomplished by turning the eyepieces.

Ambient light entering the I^2 tubes is focused by an objective lens onto a photocathode. The schematic diagram of an I^2 tube is presented in Figure 4-4. When photons of ambient light strike the photocathode, which is sensitive to visible and near-IR radiation, electrons are released creating a cascading effect.³⁸ The number of electrons released from the photocathode is proportional to the number of photons striking it.



Figure 4-1a
AN/PVS-5 (II-Gen) NVG full faceplate modified version



Figure 4-1b
AN/PVS-5 (II-Gen) NVG modified version

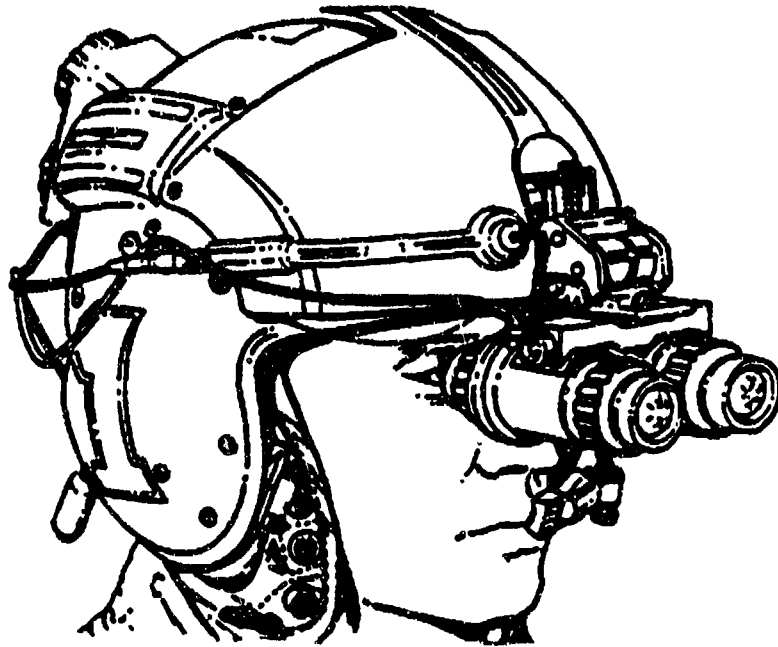

Figure 4-2
ANVIS (III-Gen) NVG



Figure 4-3
Cats-Eyes NVG

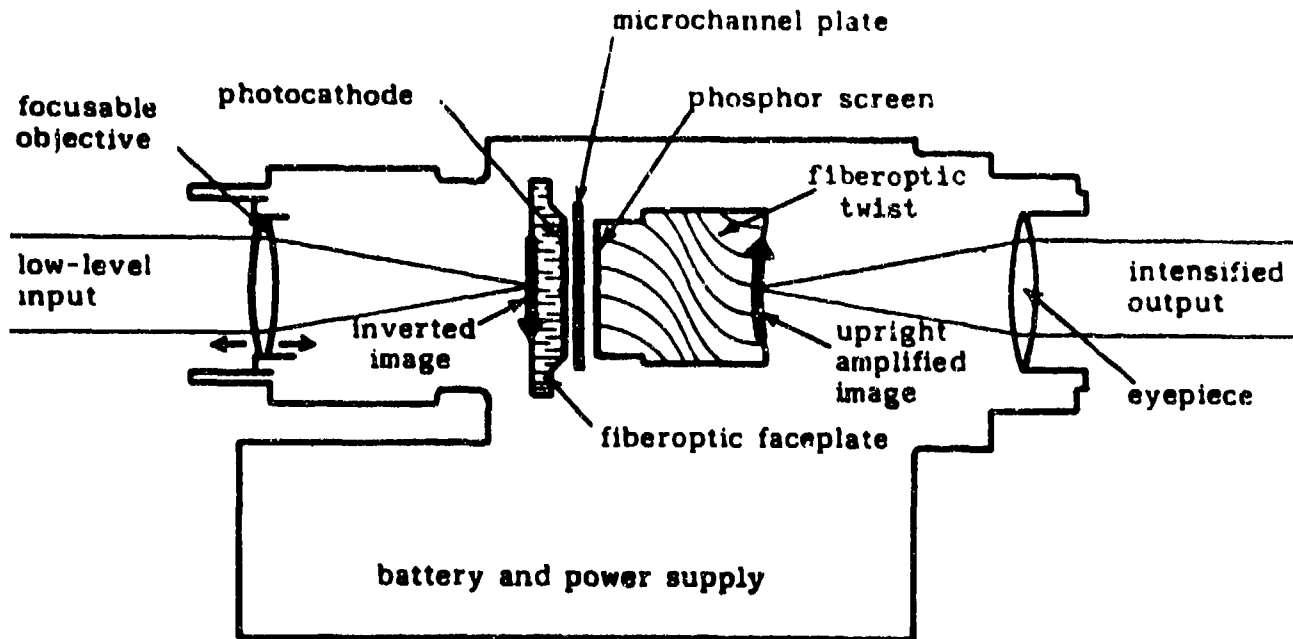

Figure 4-4
Schematic of photocathode tube

The electrons are then accelerated and multiplied by a microchannel plate which acts like a large array of photomultiplier tubes.³⁹ The microchannel plate, about the size of a nickel, guides the accelerated electrons to a phosphor screen which produces an intensified light image. The light intensification capability (amplification) is referred to as the gain of the device. Gain is the ratio of the light delivered to the eye by the phosphor screen to the light striking the objective lens.⁴⁰

Because the output of the phosphor screen is determined by both the velocity and the number of electrons, modern I^2 tubes incorporate a device called a microchannel plate. The microchannel plate, located between the photocathode and the phosphor screen,³⁹ is a very thin wafer of tiny glass tubes which are coated with a material that causes secondary electron emissions (Fig. 4-5). The glass tubes are angled so that electrons passing through will strike the walls, causing secondary electron emissions. These secondary electrons also strike the walls, and, in turn, release additional electrons. Through this chain reaction, as many as 10,000 electrons exit the microchannel plate for every single electron that enters. These electrons are then accelerated onto the phosphor screen, where their electrical energy is converted back to light energy (photons) as the phosphor is excited by the absorbed electrons. The output of the phosphor

screen is a relatively narrow band peaking at 530 nm (Fig. 4-6). Thus, the image is essentially monochromatic green, and color discrimination between objects is not possible. Finally, the amplified image is made upright by a fiber-optic inverter and focused through the eyepiece lens.

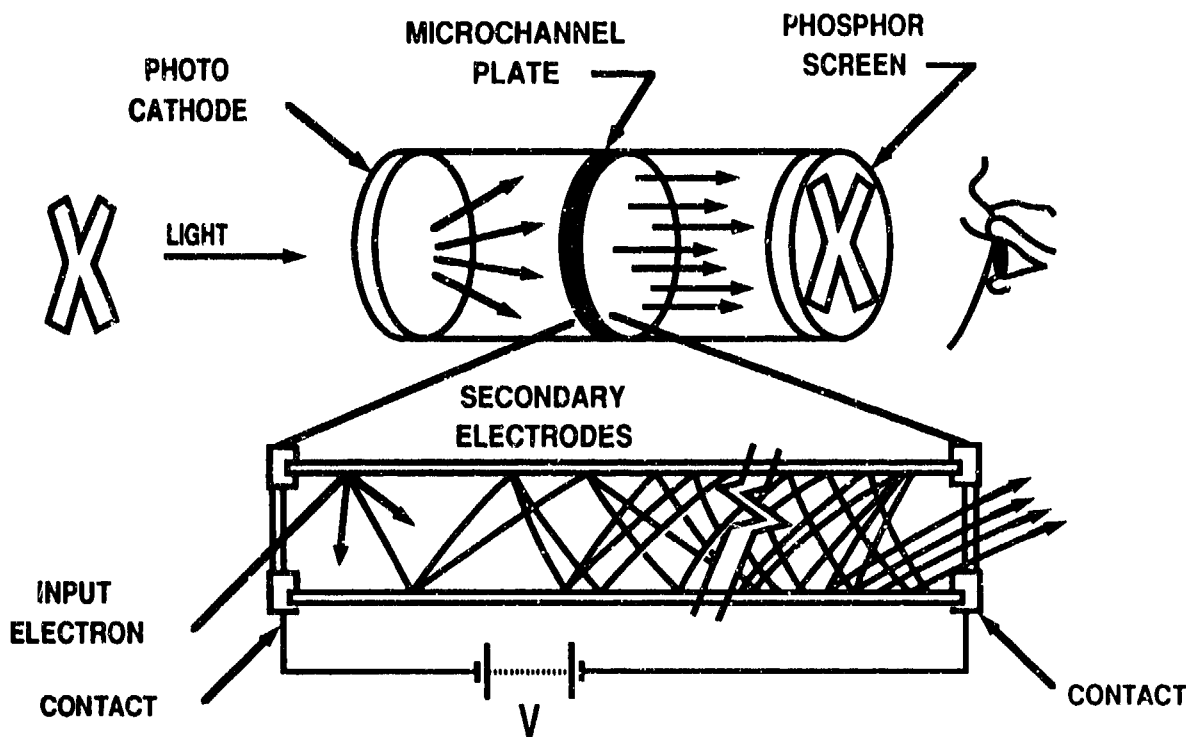

Figure 4-5
Microchannel plate function

An important feature of modern I^2 technology is the automatic brightness (gain) control. The automatic brightness control maintains a controlled voltage and prescribed image brightness.^{33,37} It monitors the I^2 tube contrast drawn from the power supply and limits the maximum tube current by reducing the voltage and, therefore, the gain. Thus, the automatic brightness control limits the maximum average luminance output of the phosphor screen to approximately 0.5 mL in the AN/PVS-5 NVG, 1.0 mL in the ANVIS,²¹ and 1.5 mL in the Cats-Eyes. A clamp voltage mechanism protects the photocathode from damage by excessively bright light sources, e.g., flares, search lights, fires, explosions, lasers, afterburners, etc. Shutdown can also occur when looking directly at the moon side of a visual scene on bright moonlit evenings.⁷

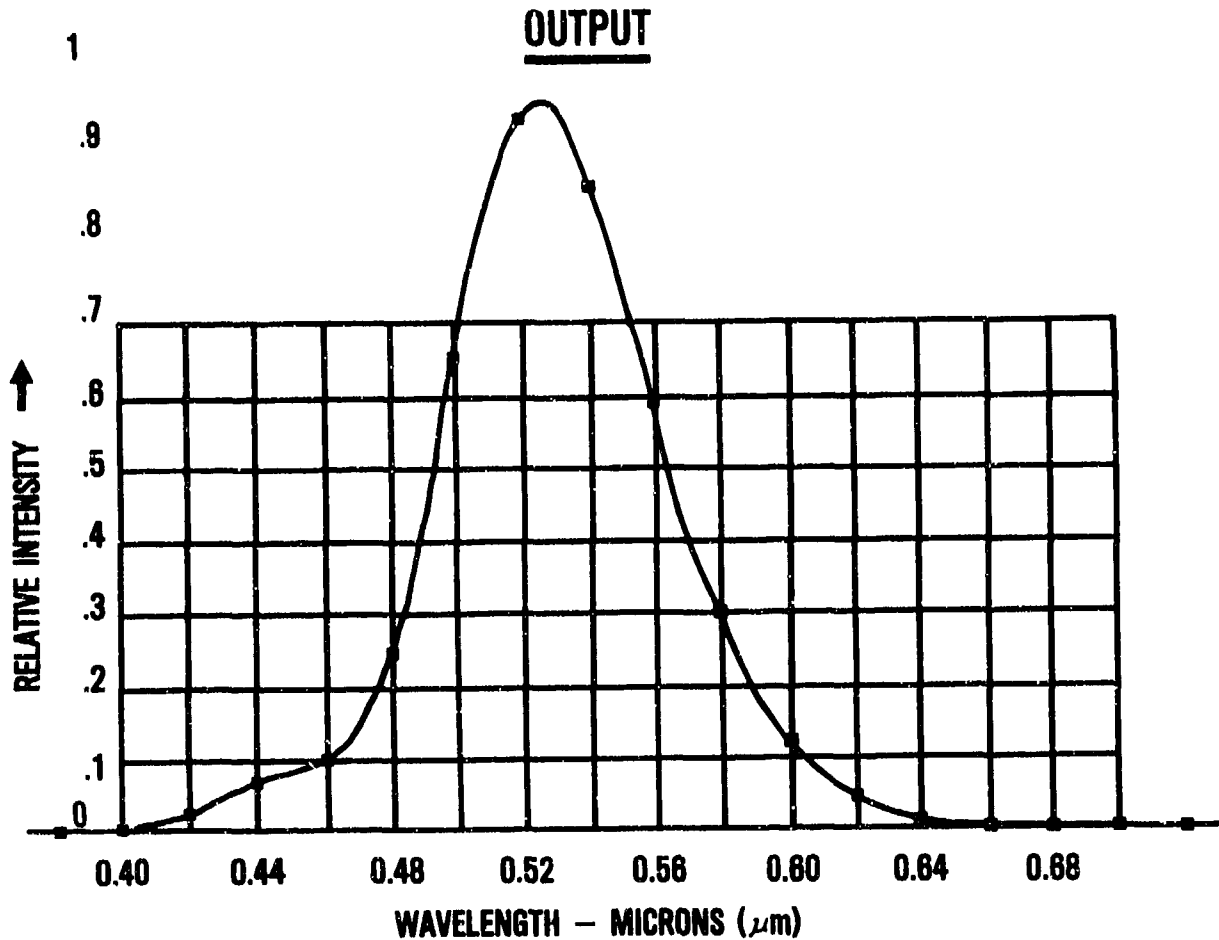

Figure 4-6
Spectral output of the NVG phosphor screen

OPERATIONAL PERFORMANCE

AN/PVS-5A

Although satisfactory for infantry use, the AN/PVS-5A was criticized by aircrew because of its poor low-light performance, frequent battery failures, and heavy weight. The major complaint with the AN/PVS-5A was its large, enclosed faceplate, shown in Figure 4-1a.⁴¹ This cumbersome faceplate severely restricted the peripheral field of view, prevented looking underneath at cockpit instruments, and was not compatible with helmet-mounted sighting systems, visors, protective masks, or standard aircrew spectacles. Because aircrew spectacles could not be worn with this NVG, aviators with significant astigmatism had reduced vision.²¹ The dioptric focusing mechanism of the NVG, which corrects spherical refractive errors that fall within +2.00 D to -6.00 D, does not correct for astigmatism. Many of these shortcomings have been overcome by the widespread adoption of the AN/PVS-5A faceplate modification (Fig. 4-1b) and the U.S. Army GM-6 Cobb helmet mount.⁴² The modification provides a

"look-under" capability and is compatible with aircrew spectacles. The AN/PVS-5 now comes in B and C versions. Only a few hundred AN/PVS-5A NVG remain in use by USAF aircrew, most of them in the Military Airlift Command (MAC). However, many flightline personnel are still using the AN/PVS-5A.

ANVIS

The helmet-mounted ANVIS (Fig. 4-2) possesses many electro-optical improvements over the AN/PVS-5A (Table 1). The basic ANVIS design is compatible with eyeglasses, has an indirect "look-under" capability that allows for more normal near and peripheral vision to monitor flight instruments, has a dual battery system with warning light, weighs less than the AN/PUS-5A, and is easily counterbalanced.³⁷

TABLE 1. ELECTRO-OPTICAL SPECIFICATIONS OF NVG

	AN/PVS-5 (II-Gen)	ANVIS (III-Gen)	CATS-EYES (III-Gen)
System gain (2856 K source)	400 minimum	2,000 minimum	2,100 (nominal)
Resolution	24 lp/mm (32 lp/mm)	36 lp/mm	36 lp/mm
f/number	f/1.4	f/1.2	f/1.2
Photocathode response			
830 nm	15 mA/W	100 mA/W	100 mA/W
880 nm	0	600 mA/W	600 mA/W
Magnification	1:1	1:1	1:1
Field of view	40 deg	40 deg	30± deg
Focus range	10" to infinity	10" to infinity	fixed (Mark III) 15" to infinity (Mark IV)
Diopter adjustment	+2.00 to -6.00	+2.00 to -6.00	none
Interpupillary distance	55-72 mm	55-72 mm	56-72 mm (10 mm vertical)
Output (530 nm)	0.5 mL	1.0 mL	1.5 mL
Power (battery)	2.7 v lithium	3.0 v lithium (2) (or 28 v DC)	3.5 v lithium (2) (1/2 AA)
Battery life	10 h	20 h	18 h
Weight	1.9 lb	1 lb	1.7 lb

The single most important technical feature of the ANVIS is its improved low-light performance. The ANVIS tube outperforms the AN/PVS-5 tube because it has improved efficiency (gain) in the red and IR region of the spectrum. Thus, the image brightness is much greater when viewing objects illuminated by starlight; hence, greater system resolution and longer detection ranges. The differences in spectral sensitivity between the AN/PVS-5A and ANVIS photocathodes is shown in Figure 4-7. The response of the AN/PVS-5A (II-Gen tubes) is somewhat similar to the human eye; i.e., it is sensitive to visible light and some IR ranging from about 400 nm to 850 nm. The ANVIS (III-Gen tubes) is only sensitive to the orange, red, and near-IR (approximately 625 nm to 900 nm), but it is not sensitive to the blue-green-yellow portion of the spectrum.

Night Vision Comparison

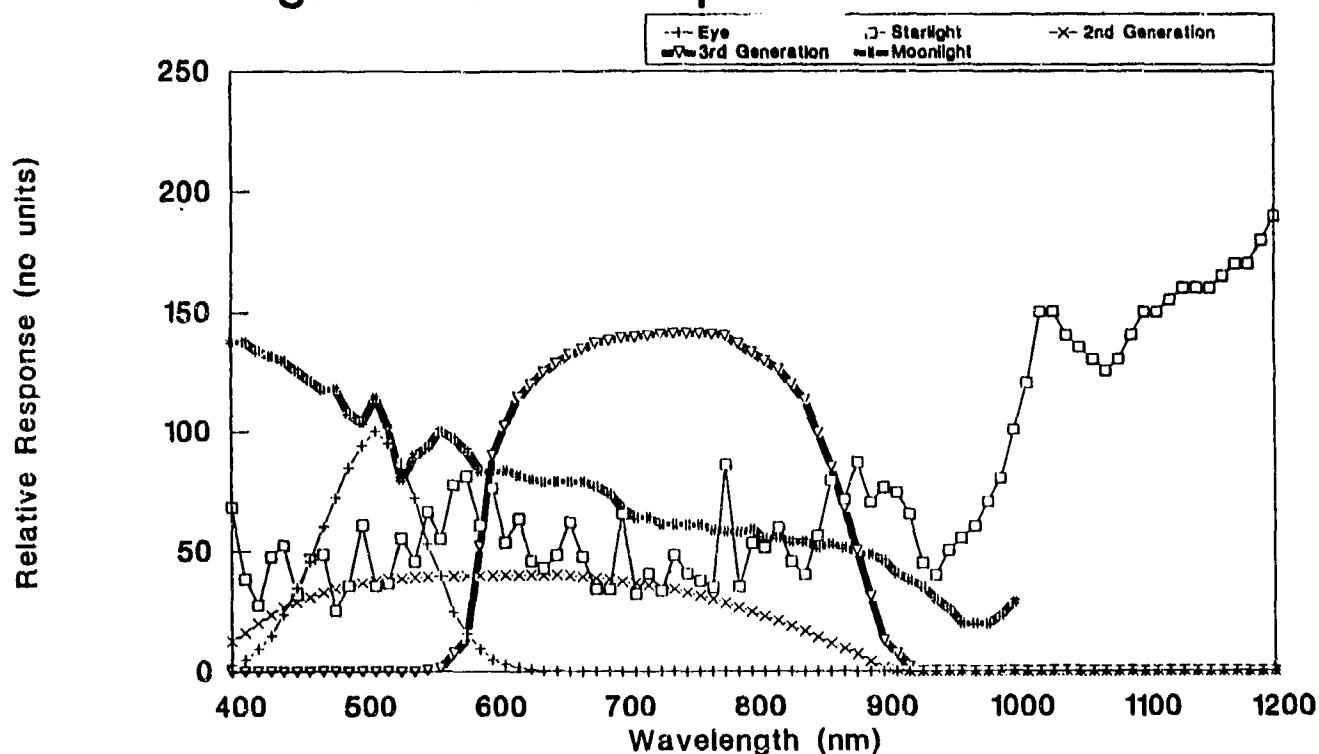

Figure 4-7
Spectral comparison of the II- and III-Gen photocathode tubes and spectral distribution of the night sky (starlight)

This limited sensitivity range may have a negative effect on target detection and identification. There are certain conditions in which the ANVIS actually performs worse than the AN/PVS-5A. This phenomenon, first reported in 1985 by the USAF School of Aerospace Medicine (now Armstrong Laboratory Aeromedical Consultation

Service) Ophthalmology Branch,⁴² and subsequently by several operational units, occurs because the ANVIS system, under certain conditions, may not reveal differences in contrast between adjacent terrain features. A good example is a low contrast scene of a road, reflecting IR light of about 900 nm which winds through grassy meadowland reflecting brownish-red light of about 600 nm. The photocathode of the ANVIS is equally sensitive to both wavelengths. Thus, the road and all of its surroundings appear equally bright green on the phosphor screen, i.e., the road cannot be seen because there is no contrast gradient. The photocathode of the AN/PVS-5A, however, is sensitive to 650 nm light, but not to 900 nm IR light. This means that the viewer will be able to see the road as a dark line running across a green background. In effect, the truncated spectral sensitivity combined with the greatly enhanced gain of the ANVIS may, under certain conditions, eliminate the contrast gradient and preclude detection.

The addition of blue-green cockpit lighting to aircraft allows ANVIS users some advantages.²⁸ The ANVIS tube is totally insensitive to the blue-green end of the spectrum, as shown in Figure 4-7. The addition of a dielectric coating (minus-blue filter) to the ANVIS optical system makes this device virtually blind to light wavelengths less than 625 nm.⁴³ As discussed previously, the sensitivity of the human eye is greatest in the blue-green region at night, making blue-green lighted cockpit instruments easy to read even at very low intensities. Also, the effects of ocular chromatic aberration make it easier to accommodate (focus) under blue light.⁴⁴ Thus, the cockpit and instrument panel can be easily seen by the unaided eye looking under or around the ANVIS, while the ANVIS, unaffected by internal glare and windscreen reflection, responds best to outside lighting which, in starlight, is predominantly red and IR (Fig. 4-7). Unfortunately, programs to convert current aircraft to blue-green lighting have not been fully implemented.

Cats-Eyes

One version of NVG made in the United Kingdom is called Cats-Eyes (Fig. 4-3); it uses standard III-Gen tubes.⁷ Accordingly, there is much similarity in performance to the ANVIS. The major difference is that in the Cats-Eyes there is a combiner lens system through which the user can see the I² image or the real image. The purpose of this combined lens system is compatibility with the Head-up Display (HUD). The Cats-Eyes have an auto-scene-reject mode which automatically turns off the NVG tubes when the pilot's eyes focus on the HUD² so that the HUD symbology can be seen through the combiner lens.

There are two versions of the Cats-Eyes, Mark III and Mark IV. The Mark III objective lenses cannot be focused, while those of the Mark IV can be focused. The I² field of view for Mark III Cats-Eyes is only 30 deg, and its best VA is about 20/70. The field of view for Mark IV Cats-Eyes is 35 deg and its best VA is 20/40. Both of these parameters are reduced compared to the ANVIS.

Another NVG model made in the United Kingdom is called NITE-OP.⁷ It has a slightly larger field of view (45 deg) than the ANVIS and comparable VA. The

NITE-OP may be used by some USAF operational units in the future because ejection seat compatibility was a design consideration in its development.

PERFORMANCE LIMITATIONS

NVG do not turn night into day.² Although pilots are usually impressed the first time they look through NVG, there are many complaints the first time they fly with them. While it is true that visual function with NVG is impressively enhanced over scotopic function in many ways, NVG performance is inferior compared to normal photopic function. The degradation in visual performance that NVG impose must be emphasized to aircrew.

Visual Acuity/Resolution

Visual acuity (VA) is a measure of the eye's ability to resolve spatial detail. The commonly used measure of VA is determined by the angular size of the smallest object resolved, which can be easily measured using elementary trigonometry.⁴⁵ The visual system is normally capable of resolving detail smaller than 1 min of arc (1/60 of a degree), which corresponds to the standard photopic VA of 20/20. VA with NVG is, at best, about 20/40 with Cats-Eyes (Mark IV), 20/50 with AN/PVS-5, and 20/40 with ANVIS.^{2,42} These VA are usually only reached indoors, under artificially controlled optimal conditions, i.e., high levels of contrast and brightness. Under typical ambient illumination outdoors, VA is often significantly decreased from these levels. One field study⁴² revealed that, under ambient starlight conditions, mean visual acuities for high contrast eye charts were reduced to less than 20/100 with the AN/PVS-5 and less than 20/80 with the ANVIS. A more recent laboratory study⁴⁶ revealed that visual acuities with low contrast eye charts were considerably worse.

When tested through an NVG, VA is a subjective measurement of the operator's visual performance using these devices. Resolution is an objective measure of the capability to distinguish a separation between two objects; it is usually expressed as line pairs per millimeter (lp/mm).^{40,47,48} Procurement, test, and end-of-life specifications for night vision devices are often defined in terms of resolution rather than VA. The resolving power of NVG decreases at low light levels because the background noise increases in the intensified image.⁴⁶ Light-amplification I² devices must have a minimum level of illumination to function effectively. At light levels below starlight, NVG may lose their operational effectiveness, even though some measurable resolution remains.

In order for the aviator to achieve maximal VA and take full advantage of the NVG's resolution capability, the ocular and objective lenses must be properly adjusted to give optimal vision and comfort.^{2,21} Each ocular (dioptric) lens is independently adjustable over a refractive error range of +2.00 D to -6.00 D (not applicable to Cats-Eyes). This dioptric lens was originally designed to eliminate the need for some aviators (those with simple myopia or simple hyperopia) to wear their spectacles when using NVG.^{49,50} However, we recommend that aviators wear their spectacles for the

following reasons: for correction of astigmatism and/or presbyopia; to see items in the crewstation when looking under the NVG; to look with peripheral vision outside the cockpit and/or judge the distance of other aircraft; to be able to see immediately after flipping up the NVG; and to afford eye protection from flying debris or sudden impact. To ensure relaxed accommodation and prevent eyestrain, the aviator must know how to adjust the ocular lenses properly: Turn the dioptic ring fully counterclockwise and then slowly clockwise until the first clear focus is obtained to ensure relaxed accommodation and prevent eyestrain. The ocular lenses are not adjusted until after the objective lenses have been focused for the testing distance, which is normally 20 ft or more.

In the human visual system, the eyes focus simultaneously and equally over distances from about 10 in. to optical infinity, i.e., distances greater than 20 ft. This variable focusing ability can occur consciously or unconsciously and, depending upon age, is relatively instantaneous. The near-to-distance objective focus on NVG is quite different. The objective lenses on each I² tube must be manually and independently focused over a range from 10 in. to infinity. Misadjusting the NVG objective lenses may reduce the ability of the aviator to see and detect distant objects because of the inherent poor depth of focus. The aviator should view an object that is at least 20 ft away when setting the focus of the objective lenses for distant viewing. Some NVG may require a 30-ft or even longer viewing distance for optical infinity.⁴⁰ The objective lens of each I² tube must be manually readjusted in order to view objects closer than 20 ft. Pilots do not need to refocus the NVG for viewing inside the cockpit because they can use the "look-under" capability. For final preflight testing, the aviator should view a target through the aircraft windscreen. Some windscreens may have induced prismatic power in them which will defocus the NVG image.²⁶ All wind screens have different spectral transmission characteristics, e.g., in the red and IR range, which are very important considerations.

Proper adjustment of the NVG tubes for the interpupillary distance is also very important. The interpupillary distance is the distance separating the two eyes, i.e., the distance between the centers of each pupil. Some aviators believe that spreading the tubes further apart than their interpupillary distance will increase the field of view. This is simply not true and will, in fact, impair their NVG performance.⁴⁰ The tube images should completely overlap, but this may be difficult to accomplish. Even small misadjustments in interpupillary distance can degrade VA and cause eye strain and fatigue. Methods for measuring interpupillary distance and setting the NVG tube separation distance can be obtained in the optometry clinic. All spectacle-wearing aircrew have an interpupillary distance entry in their medical records.

Field of View

Under binocular conditions, the normal unaided field of view measures approximately 120 deg vertically by 200 deg horizontally. For both the ANVIS and AN/PVS-5, the field of view of a single I² tube is a circular 40 deg.⁵¹ The tubes have 100% overlap; hence, the combined binocular field is also a circular 40 deg. An illustration of the unaided and NVG binocular fields of view is provided in Figure 4-8. The field of view of the Cats-Eyes NVG is less, approximately 30 deg for the Mark III and 35

deg for the Mark IV. Thus, a tremendous field-of-view reduction occurs with NVG use.

Field of view with the NVG is a theoretical value; it is based on one's ability to obtain minimal eye relief and proper eye positioning within the designed eye positions (Fig. 4-9) of the NVG optics.⁵² Eye relief, used synonymously with vertex distance, is the distance from the back surface of the NVG's ocular lens to the front surface of the eye. If this distance is greater than 20 mm, the field of view for ANVIS or AN/PVS-5 users decreases significantly. Variations in head anthropometry, e.g., deep-set eyes, using other life-support equipment or protective masks,⁵³ or wearing corrective spectacle lenses, may prevent proper eye relief, further reducing the field of view. Improper adjustment of the helmet attachment can also reduce the field of view. These additional field-of-view losses are not always obvious to the aviator. The greater-than-normal amount of head movement which is required to compensate for the reduced field of view may contribute to task management overload. Unfortunately, it is difficult for manufacturers to design new NVG with a wider field of view because, as you increase the field of view, the weight and size of the objective and eyepiece lenses increase significantly.⁵² Enlarging the field of view decreases resolution because the image is spread out.

The aviator must continually use head movements to scan and help compensate for the NVG's limited field of view. The effects of the reduced field of view on flying performance are not fully understood. The problem of determining the minimum field of view required for flying is not a simple one, because it is extremely task-dependent. Although the circular 40-deg field of view with NVG seems small compared to the normal ocular field of view, the effect is tempered somewhat by the fact that the view of the outside world from the cockpit is obstructed in some aircraft.

Binocular versus Biocular Vision

The human visual system is binocular in nature. In binocular systems, visual inputs from two separate sensors, each slightly displaced in space, are stereoscopically fused in the brain. A similar configuration is used in the AN/PVS-5, AN/AVS-6 (ANVIS), and Cats-Eyes, where two separate I² tubes, one in front of each eye, are the sources of the visual input. A variation on this design is a biocular system where one I² tube provides visual input to each eye by means of a beamsplitter prism. This configuration is used in the AN/PVS-7,⁵¹ which has a III-Gen tube and is destined to replace the AN/PVS-5 currently used by flightline personnel. However, the single I² tube has not been authorized for use by USAF aircrew because of the lack of tube redundancy in the event of failure, although there are other advantages to binocular systems.

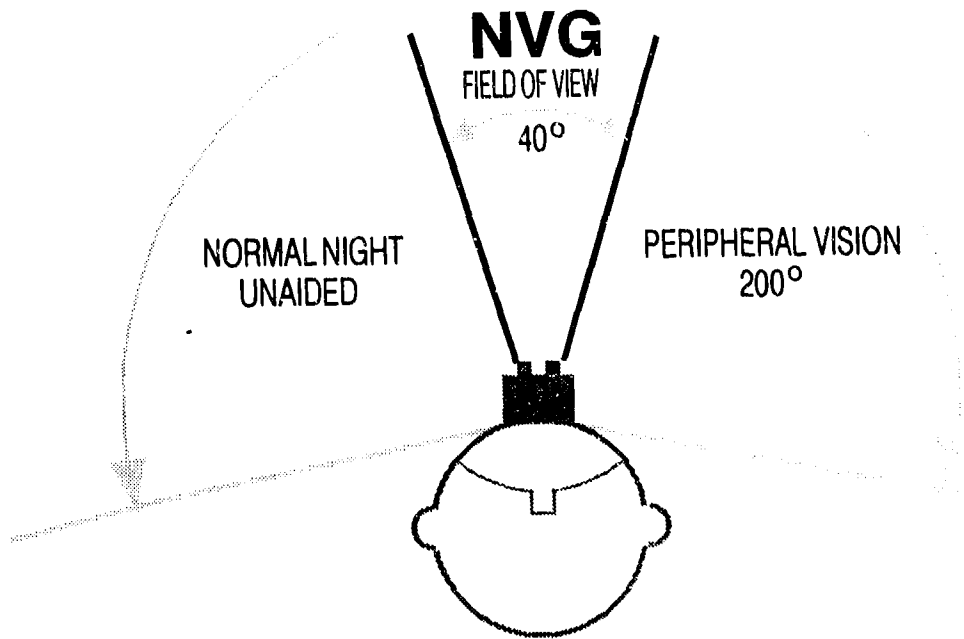

Figure 4-8
Unaided binocular field of view

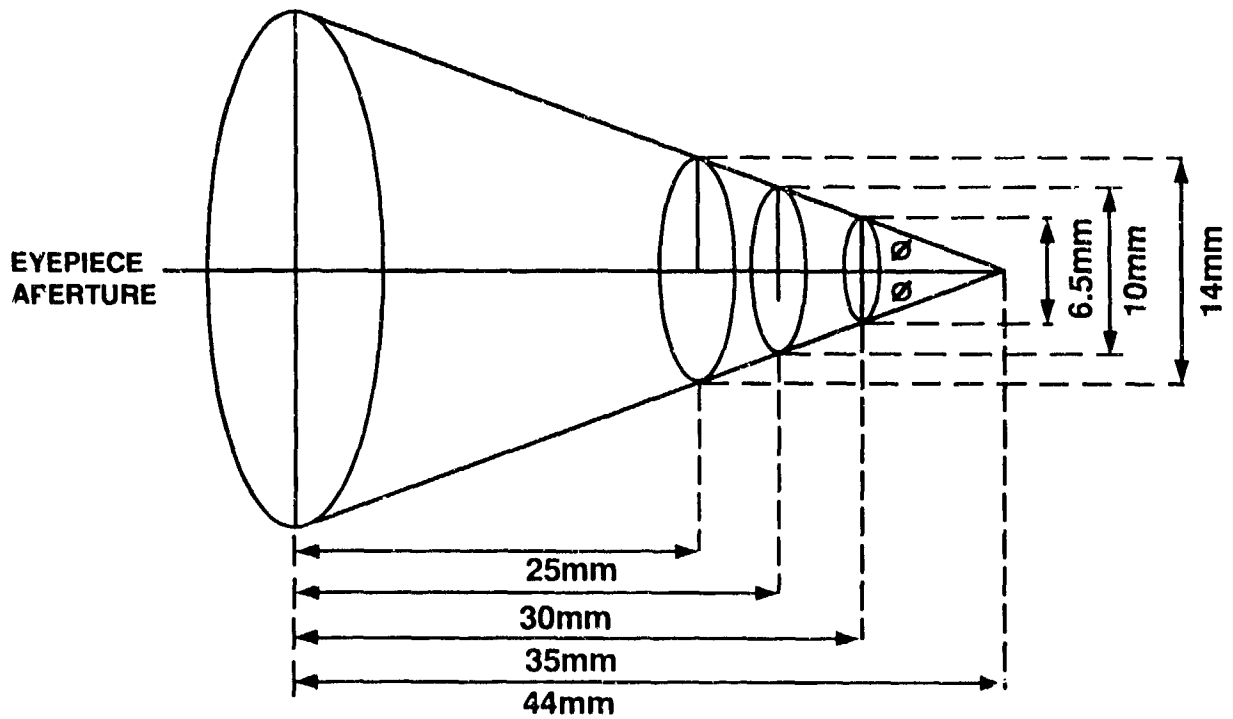

Figure 4-9
Relationship between designed eye position and eye relief

I² images often have background noise which appears as scintillation, commonly called sparkles or snow.^{40,46} The noise increases as the ambient light level decreases, and it is more visible in II-Gen than in III-Gen tubes. These scintillations may block the resolution of detailed information. Since the intensity and location of the noise varies with time, it is unlikely that a scintillation will appear at the same place and at the same time in both tubes of a binocular system. Therefore, the perceived image quality may be better in a binocular system, compared to a biocular system because the degradation from background noise is less. Binocular systems also generate slightly brighter images for the viewer than biocular systems, due to binocular summation, i.e., the fact that each eye has a full input from a separate I² tube, and these two inputs are partially additive, or summated, at the cortical level. The luminance output of a single I² tube in a biocular system is divided, with one half being presented to each eye. At low contrasts, the binocular summation effect for VA is most critical. An additional benefit of binocular systems, particularly for aviation, is redundancy. If one I² tube goes down, the other one may still function. Compared to biocular systems, increased cost and weight are obvious liabilities of binocular systems.

Depth Perception

Binocular systems might be expected to provide improved depth perception, the ability to judge the relative location of objects in space. Objects seen with some NVG will have a tendency to look farther away than normal. This is a learned, subconscious phenomenon because we expect objects that are less distinct in detail to be farther away than those with sharp detail. On the other hand, some NVG have an induced plus or minus prismatic effect from optical axis misalignment of the tubes⁴⁰ which may create an impression that objects are closer or farther away.

Depth perception with all NVG is limited,^{37,54-57} because good VA is necessary for most monocular cues involved in judging distances, e.g., retinal image size, motion parallax, overlay, texture gradient, etc. Stereopsis, which is the ability of the observer to judge depth by fusing the two dissimilar retinal images created by the separation of the two eyes, is also reduced because of the decreased resolution. Accordingly, retinal image size and overlay are probably the most important cues to the limited depth perception that is available with NVG.

The aviator's ability to judge depth while using NVG is critical, particularly during confined-area maneuvers, such as in landing zones,⁵⁸ while hovering, and during nap-of-the-earth flight. Studies have shown that the available depth perception cues with NVG are, at best, equivalent to performing these maneuvers with only one eye during the day.³⁷ The ANVIS normally provides better depth perception cues than the AN/PVS-5, since it has somewhat better resolution. Accommodation and convergence information are weak binocular cues used for unaided depth perception, but they are not available to NVG users.

Other Parameters

There are several other measurable parameters that affect the performance of the I² tubes in NVG including spectral response, signal-to-noise ratio, equivalent background input, sensitivity and gain.^{40,46} There are also defects in the I² tubes that can degrade their performance. Some of these tube characteristics are fixed at the time of manufacture, and others may change during the lifetime of the tube. When the tube is manufactured, it has a certain spectral response based on the chemical composition of its photocathode. The II-Gen and III-Gen tubes have different spectral responses (Fig 4-7). Even though objects may appear to have the same shape when viewed through the two different generation tubes, they often have entirely different intensities. For example, dirt roads against green grass appear very dark through II-Gen tubes, but appear bright through III-Gen tubes.⁴² Therefore, the contrast and the visibility of objects is related to the specific generation I² being used.

The contrast and resulting image quality is a function of the signal-to-noise ratio of the intensifier tube. Signal is the information transmitted through the intensifier. Noise is unwanted disruptions of the signal. The II-Gen tubes have lower signal-to-noise ratios than III-Gen tubes.⁴⁶ The signal-to-noise ratio of II-Gen tubes continues to decrease throughout their 2,000 to 4,000 hours of useful life. The signal-to-noise ratio of III-Gen tubes tends to remain more constant over their 7,500-hour life but then falls off rapidly. End-of-life is defined as the point where the signal-to-noise ratio falls below a prescribed value.³⁷

Another important factor affecting imaging quality is the equivalent background input, or noise, which is a measure of the luminance output of an I² tube with no input. This parameter is important because, if the equivalent background noise is too high, the contrast of the intensified image may be too low.⁴⁶

The sensitivity of an I² tube, whether II-Gen or III-Gen, is established when it is manufactured. The sensitivity of II-Gen intensifiers gradually decreases over time.⁴⁰ However III-Gen intensifiers are designed to maintain a relatively constant sensitivity over time. The eventual loss of sensitivity results in a weakened signal and, thus, a lower signal-to-noise ratio signaling the end-of-life for the tube.

The gain of an I² is the ratio of signal-out to signal-in, i.e., light out to light in.⁷ Tube gain is controlled primarily by the tube's power supply. Increasing the voltage between elements in the intensifier tube increases its gain. When the tube is new, increasing the gain increases both the signal level and the noise level. At some point in time near end-of-life, as the sensitivity of the tube decreases, increasing the gain will increase the noise more than the signal, thus decreasing the signal-to-noise ratio.

Tube defects may also affect image quality. Minor defects are normal and may be present when the tubes are accepted from the manufacturer; others may develop during the life of the device. Some black spots, fixed pattern noise, and distortion are permissible in new I² tubes.⁷ The size, location, and number of black spots should be measured and compared with a specification to determine if they are acceptable.

Large spots in the central area of the tube image that are big enough to block detection of objects the size of aircraft are unacceptable. Fixed pattern noise may appear as a faint geometric pattern in the internal fiberoptics. If the fixed pattern noise exceeds the military specifications, the tube is rejected.

Because the optics of most I² tubes provide an inverted image at the phosphor screen, a fiberoptic 180-deg twist is used to correctly orient the image.^{7,40} During the manufacturing phase, however, imperfections in bending and twisting the fiberoptic bundle may create a wavy type of distortion (called "S" distortion) of the optical axis. If the two I² tubes are not well matched for this "S" distortion, the aviator may experience some asthenopia, even if each tube meets the military specifications. Binocular axis alignment may also be a problem with NVG when the input/output axes of the ocular system are not the same. The effect created is like wearing weak prisms in front of the eyes with the lenses in random directions. Some NVG may have significant binocular axis alignment problems that cause eye fatigue and, with long-term wear, headache.

Finally, distortion of the internal fiberoptic inverter should be measured. Excessive distortion levels can cause depressions or bulges in images of flat surfaces. Tubes exhibiting this level of distortion are obviously unacceptable for flight.

The aircrew member always has the preflight responsibility of rejecting any NVG with unacceptable performance characteristics. A schedule for routine inspection of NVG to ensure adequate performance should be established. Fortunately, with sufficient training and experience, the aviator can learn to function relatively well with the artificial vision created by NVG. The limitations, however, must be continually emphasized to aircrew members using the NVG on night missions. Consult Appendixes C-E for brief summaries of NVG capabilities and operating instructions.

CHAPTER 5

NVG AND HUMAN FACTORS CONCERNS

OPERATIONAL ISSUES

The NVG binocular design (two independent tubes) used for aviation provides an inherent redundancy for the I² optics. However, battery failure is more likely than tube or electro-optic element failure.⁵⁶ Battery redundancy is provided by a dual battery pack attached to the back of the helmet, with a switch to select either the primary or spare battery. Battery failure is signaled by the low battery indicator; it can also be detected visually when both intensifiers exhibit luminance variations, usually followed by a complete failure of both tubes.

Flares, rocket motors, strobe lights, lightning, lasers, and other bright light sources may temporarily or permanently interrupt the performance of the NVG. The interruption may last only a few seconds, but, if unexpected, it may be quite disconcerting. The I² tubes have a protective device that will shut down the gain when excessive bright light is encountered dimming the output and lowering the image resolving power. When the bright light disappears, the normal gain returns electronically and rapidly. Since this protective device limits the light passed to the eye, recovering from a flash through an image-intensifier is much more rapid than recovering from a flash to the unaided, dark-adapted eye. It only takes a few seconds for the NVG to recover compared to about 30 min for the eye. The eyes are able to adjust to the goggles almost instantaneously, without any dark adaptation required because the output image is in the high mesopic or low photopic range of luminance. However, when the NVG are flipped up and the flyer returns to unaided night vision, it may take 2-4 min to fully recover dark adaptation.

The use of NVG does not require scotopic vision because the output brightness of the I² tubes is in the low photopic or mesopic range. This output brightness will affect dark adaptation, but not to a great extent.⁵⁹ A U.S. Army study found that recovery to normal thresholds of dark adaptation was attained within 3 min after removal of the NVG.³⁷

Some aircrew members have complained of an orange to brown after-image that persists after an extended period of NVG use which is most probably a form of temporary photoreceptor fatigue.^{7,25} It is a very normal and transient physiological effect. The eye has three primary color sensors (cones): blue, green, and red. All other colors are seen by a combined stimulation of these three primaries. The NVG output is a green light which saturates only the green receptors; it does not stimulate the red and blue receptors. After the NVG are removed, the red and blue cones are supersensitive and very active, while the green cones are subdued. The output of the red and blue cones then combines to produce a brown after-image. It affects people differently and usually only lasts for a few minutes, depending upon on how long the NVG were worn. It is a normal physiological effect and will not cause any permanent

change in vision. Potential problems in color discrimination could occur, however, immediately upon flipping up the NVG.

In 1986, a report surfaced that wearing NVG had caused three helicopter pilots to temporarily fail the near depth perception (stereopsis) test.^{60,61} An investigation indicated that improper interpupillary distance adjustment had forced the eyes to converge or diverge incorrectly, thereby causing errors in binocular viewing. The report concluded that this phenomenon only affected near depth perception and a return to normal vision could occur in as little as 1 hour after NVG removal. This report was viewed with widespread skepticism, and no further reports of this phenomenon have surfaced.

The output image of the NVG is presented to the aviator on a green phosphor screen. All color information from the surrounding environment is converted to shades of green. It is particularly important to remember this when viewing color-coded information from external light sources, such as aircraft navigation and tower lights. The lights on approaching and departing aircraft, color-coded taxiways, and runway lights may not look the same.

Brightness intensity often provides distance cues, but these cues can be easily confused at night with NVG. Because of the spectral sensitivity of the photocathode, a light source may appear the same to an aviator using NVG, whether it is bright and close or dim and far away. Lights from other aircraft often blend in with ground lights,⁵⁶ and midair collisions have occurred because aircrews were not able to differentiate lighted aircraft in their flight path from background lights. Anticollision strobe lights improve the detection of aircraft, but not without tradeoffs. Often, the high-intensity xenon strobe lights interfere with the NVG and distract aviators because the light reflects off the rotor blades and nearby objects during terrain flight. The center of the anticollision light, however, can be covered with opaque tape to prevent unwanted reflections. Some newer aircraft use dim IR lights or IR tape that is visible only with NVG, to covertly mark their position.⁷

Clean, dry, unabraded windscreens, visors, spectacles, and NVG optics are essential to optimum performance. Light from internal and external sources may scatter off dirt, grease, moisture, and abrasions on the windscreen and reduce the contrast of the NVG-intensified scene. The visual degradation is analogous to that created by oncoming headlights seen through a dirty, wet, pitted vehicle windshield at night. To prevent fogging of the NVG eyepieces, demist shields can be installed. Information, obtained prior to aircraft accidents, concerning the optical condition of windscreens, transparencies, and NVG optics, might be helpful in accident investigations.

INTEGRATION WITH LIFE-SUPPORT EQUIPMENT

Integration of NVG with life-support equipment may create some problems. For example, NVG are not totally compatible with chemical defense (CD) respiratory masks^{51,52,53} because CD masks have optical lenses that protrude away from the eyes. Although an NVG can be adapted to fit in front of the CD mask, the I² eyepieces may have too great an eye relief reducing the NVG field of view below 40 deg.

A recent study reported that the Aircrew Eye Respiratory Protection (AERP) mask, worn in combination with the ANVIS NVG, reduced the normal intensified field of view from 40 deg to about 33 deg.⁵³ When the AN/PVS-5 was worn with the AERP system, the reduction was quite similar. Another study found that the AN/PVS-5 intensified field of view may be reduced to as little as 21 deg when worn with the MCU-2/P CD mask.⁵¹ Thus, life-support equipment that moves the NVG farther away from the eyes may have a profound effect. The 40-deg field of view provided by NVG is already so narrow that it creates problems when flying combat aircraft. Any further reduction in the field of view could create severe flight safety problems.

NVG compatibility with aircrew spectacles is usually not a problem, except in those rare individuals with deepset eyes or in those with spectacles that fit out away from their face.⁶² Laser protection is provided by light interference filters (LIF) which fit on the NVF objective lenses.⁶³ Dust/wind protective goggles usually create problems with NVG vertex distances. Many aircrew members, e.g., backseaters in helicopters or C-130 aircraft, need dust/wind protection.⁶⁴ A satisfactory solution for this problem is elusive.

Placing the NVG on the flight helmet has significantly increased the weight that must be supported by the neck.⁶⁵ Counterweights on the back of the helmet are used by aircrew to offset center of gravity shifts. The effects of placing additional weight on the aviator's head can create muscle fatigue. Head-neck muscle strain may cause slower head motions and affect reaction times associated with movements of these muscle groups. Slowed reaction times could contribute to decreased maneuvering accuracy. However, the quantitative relationship between weight, fatigue, and performance degradation has not been documented.

Of great concern are the additional G-forces which will be present during crashes and ejections.⁶⁵ Increased weight on the head has profound effects in crash dynamics that are a direct result of the additional mass. In the absence of external force, and neglecting forces due to the neck muscles, the total internal force exerted on the skull base during acceleration is approximately equal to the product of the total mass of the helmeted head and the head acceleration. Thus, for a given head acceleration, the larger the mass (head-supported weight), the greater the force and risk for injury. The current NVG and the accompanying counterweights are designed to break away at specified G-force levels. For example, the ANVIS should break away from the aviator's helmet at a head acceleration of 10-15 G to reduce the total head/neck/helmet-mounted device mass during the critical period of high accelerations. Accident data revealed that neck injuries were responsible for death in some aviators who were wearing NVG at the time of impact.

COMPATIBLE COCKPIT LIGHTS

Cockpit lighting incompatibility has been listed as a contributing cause in several investigation reports of NVG accidents.³⁴ NVG incompatibility with aircraft cockpit lighting has been a difficult problem to solve. The gain of an NVG is so high that even a small amount of light inside the cockpit will be too bright for normal I²

function. To solve this problem, the ANVIS III-Gen tubes were designed with a minus-blue filter, thereby rendering them "blind" to the blue-green portion of the visible spectrum (Fig. 4-7). Thus, in an airplane with only blue-green cockpit lights, the ANVIS would not be sensitive to the lights in the cockpit and to most reflections off the windscreen and internal glare problems.²⁸ Blue-green lights have some other important benefits. It is easier for the unaided eye to see the instruments under blue-green light conditions for several reasons. First, blue-green light is easier to focus (accommodate) because of the chromatic aberration of the eye (Fig. 3-3). Short wavelength light rays are bent more by the prismatic effect of the ocular lens, which means that aircrew members will have to accommodate less and will see the instruments more clearly and more comfortably. Second, the Purkinje shift (Fig. 2-8) at night provides more sensitivity to blue-green light than to red light. This means that the eye can easily see lower levels of blue light at night compared to red light. Third, blue-green light has a decreased IR signature, so that the enemy cannot detect it with NVG. However, blue-green light is somewhat easier for the enemy to see with the unaided eye at night.

To achieve compatibility with ANVIS NVG, the cockpit lights must have a brightness spectrum that does not overlap into the spectral sensitivity of the I² tubes. Successful methods for illuminating flight instruments include floodlights, external bezels, integral filtered incandescent lamps, and LEDs or electroluminescent lamps. The best methods include more than just taping over light fixtures to block unnecessary light or using Glendale green film taped over various displays. Unfortunately, what is made compatible for a dark night may be unreadable in bright sunlight. Therefore, a standard method of defining and measuring NVG light compatibility was developed through the adoption of a military lighting specification (MIL-L-85762A). This military specification requires daytime and nighttime instrument readability without causing interference with the NVG goggles. The object of this specification is to allow the pilot or crewmember to see the instruments and displays in the daytime and to view them at night by looking under or around the NVG and then return to the NVG to view the scene outside the cockpit.

Another consideration is the external lights of aircraft. Exterior aircraft lights should be turned off or modified to mask their view from the cockpit. Modification will be needed to allow formation flying and detection of aircraft by other NVG-equipped aircraft. NVG-compatible exterior lights will have to be greatly filtered and will be essentially invisible to the unaided eye. Recently, electroluminescent blue light panels have been retrofitted into some aircraft, e.g., the A-10, for improved detection by the unaided eye, yet remain invisible to the ANVIS NVG.

ENVIRONMENTAL CONSIDERATIONS

Ambient conditions, including reduced illumination, weather, cloud cover, and obscurants, can greatly affect the performance of NVG. Some of these environmental conditions enhance while others degrade NVG performance. As amplification devices, NVG must have a minimum amount of ambient light energy for acceptable performance. The major sources of this energy are the moon, stars, and artificial lighting. Energy from natural sources such as the moon and stars, and energy from artificial sources

such as nearby towns or tactical flares, reflect from objects. The composition, surface characteristics, and environmental conditions determine the amount and spectral distribution of the reflected energy that reaches the NVG. The moon and stars emit a significant amount of energy that cannot be seen by the human eye, but can be seen using the NVG. The stars are a uniform omnidirectional source of energy, while the moon, like the sun, is a point source of energy that casts shadows as it moves across the sky. Information providing the percent of moon illumination, rising and setting times, and maximal moon angle above the horizon are available from the weather service and from USAF navigation charts for specific geographic areas.

The current policy of most military services restricts NVG flights to periods of natural illumination which meet or exceed the lunar conditions of 20% moonlight at 30 deg above the horizon.⁶⁶ These restrictions can be waived by the commander. An exception to this restriction applies when the aircraft is equipped with an artificial IR search or landing light. The policy was implemented when only II-Gen tubes were available and does not require aviators to use IR light, but must have it available. The policy has not changed with the fielding of the more sensitive III-Gen devices.

The direction of flight, with respect to the location of the moon, sky glow, and ground lighting, is critical to NVG performance. Flying toward light sources will reduce the effectiveness of NVG, similar to flying toward the sun during daylight. Flying away from light sources may enhance the NVG image. Shadows cast by terrain features and manmade objects are important considerations for aviators. Wires are usually not visually detectable at sufficient ranges with NVG, but often the support poles and towers provide clues to the existence and path of the wires.⁶⁷ The configuration of external light, with respect to the aircraft's direction of flight, can enhance or mask shadow cues.

Atmospheric conditions can also significantly affect NVG performance. In general, atmospheric conditions that degrade unaided visual performance will also degrade the performance of NVG. The light energy reflected from objects, except for the near IR, is scattered by water vapor and particulate matter suspended in the air. Optimal NVG performance is obtained on a clear, dry night. Precipitation (rain, snow) and obscurants (fog, dust, smoke) degrade the performance of NVG. Aviators with minimal experience often overextend themselves by failing to recognize gradual degradation in performance due to deteriorating atmospheric conditions. NVG maintain a constant average display luminance over a wide range of input energy. Therefore, it may not be obvious to the aviator that conditions are deteriorating. The experienced NVG aviator has learned that deteriorating environmental conditions are indicated by an increase in image noise. High visual noise levels indicate that the device is operating at its performance limit. The presence of cloud cover can increase or decrease the amount and distribution of light available to NVG. Cloud cover may attenuate the light from natural sources but enhance the amount available from artificial sources, e.g., sky glow from towns, shopping centers, and highway lights.

Modern artificial lights, by design, produce a large percentage of their light energy in the visual portion of the spectrum; because II-Gen tubes are sensitive to all of the visual spectrum and will collect all of the artificial light. However, III-Gen tubes are sensitive to only a portion of the visible spectrum and will not collect all of the

artificial light (Fig. 4-7). Therefore, energy generated by artificial sources may be more beneficial to II-Gen NVG than to III-Gen devices, depending on the wavelengths present.

Once the aviator is assured that the NVG are operating properly and the environmental conditions will permit NVG flight operations, the next major concern is the internal cockpit lighting environment. Any bright light emitting energy in the same range of wavelengths that the NVG are sensitive to may produce a severe veiling glare that can obscure the overall image and degrade the performance of the NVG.⁶⁸ To prevent these glare effects, and to protect the image-intensifier assembly from permanent phosphor burns, NVG are equipped with a bright-source protection circuit, an automatic gain control. This circuit decreases the sensitivity of the I² tubes when they are exposed to strong energy in the NVG-sensitive portion of the electromagnetic spectrum effectively reducing the aviator's capability to view outside the cockpit. Special lens caps can be made to attenuate the extraneous light from a standard military flashlight; there is enough light to permit mapreading, yet not enough to degrade the NVG. These special lens caps can be obtained from the Armstrong Laboratory Optic Research Unit, Brooks AFB, Texas.

FATIGUE

Pilot fatigue is one of the most serious aeromedical concerns in military aviation.^{2,69} In round-the-clock combat operations, aircrew members work for exceptionally long hours with few opportunities for sound sleep. What little sleep is obtainable is usually intermittent, disrupted, and not very restorative. Aircrew who are expected to fight through the night and rest during the day are uniquely stressed. Stressors include cumulative exposure to disrupted circadian rhythms, reverse-cycle work shifts, sleep loss, and daytime sleep difficulties. Spatial disorientation increases logarithmically with fatigue.

All humans have an internal biological clock that programs cyclic fluctuations in body temperature, blood pressure, heart rate, adrenal gland output, cerebral neurotransmitter levels, and other functions. This internal circadian timing system maintains a 24-hour consistent organization of these physiological functions. While the light-dark cycle is of overriding importance, other environmental parameters, e.g., meal timing, social interaction, etc., also serve to synchronize the circadian timing system.

A pronounced lull in performance, mood, and attitude occurs in the early morning hours (0300-0600) when body temperature is at its lowest daily level and a person is normally asleep.⁶⁹ A noticeable drop in performance occurs in those early morning hours, even if an aircrew member remains awake through the night. This predictable circadian lull in the middle of the night can affect an aircrew member's state of alertness and readiness to safely perform night flight. Laboratory tests have shown that cognitive performance declines by as much as 10-15% in the early morning hours.² This decline can reach 35-40% for personnel who are sleep deprived. Along with the performance decrement, a decline in motivation and initiative and a concomitant increase in sleepiness and fatigue occur.

Aircrew who fly and fight at night, but sleep during the day, should try to adjust their circadian rhythms.⁶⁹ The natural body rhythm is timed to work during the day and sleep at night. Reversing work/sleep shifts disrupts the timing of normal sleep and activity and causes noticeable effects on alertness, fatigue, and work efficiency. When reverse-cycle work shift changes occur, it usually takes about two weeks (longer for aviators over 40 years of age) before complete adjustment of bodily rhythms is accomplished. Unfortunately, about 20% of the population cannot ever adapt to reverse day/night cycles.² Thus, night fighters should spend a few weeks living on night schedules to reverse their circadian rhythms and fully adapt before conducting combat operations. Because of the exigencies of the battlefield, this period of adjustment may not be an option. More likely, the scenario of shifting back and forth from one schedule to another in a matter of days may occur and greatly complicate circadian adjustment.

To maintain optimum levels of alertness, 6-8 hours of sleep per 24-hour day are required. When aircrew members do not obtain the required amount of sleep, a sleep debt develops that can accumulate day by day. Partially sleep-deprived pilots develop increasing levels of fatigue. Sleep debts must eventually be paid back. After a few days of sleep shortage, aircrew members must obtain a lengthy sleep. Restful sleep for 8-12 hours will generally restore alertness to acceptable levels. Night flyers quickly build up substantial sleep debts because it is often difficult to get enough quality sleep during the day at an operational air base. An old axiom that is particularly valid at night is that "a tired pilot is not a safe pilot."

When wearing NVG during night operations, aviators are not only performing arduous mental and physical tasks, but they are also working at the nadir of normal biological cycles, shifting sleep/work schedules and being stressed by the inherent danger of their missions. Without adequate rest or sleep, the aircrew member may not overcome the induced fatigue and may experience symptoms of reduced awareness while flying. These symptoms include easy distractibility, inattention to detail, slowed reaction time, poor judgment, irritability, and coordination problems. Early recognition of fatigue and its effects on performance is necessary in order to prevent serious errors in judgment.

Using NVG, aviators can fly under low ambient light conditions that are too dangerous, if not impossible, with unaided vision. However, they may entice the aviator to fly in conditions that exceed one's physiological and psychological limits. When we mix the requirements for sustained vigilance during a low-level NVG flight with the known circadian lull in the middle of the night and a sleepy pilot who has built up a sleep debt over several days of sustained operations, flight safety is at risk. To be able to get enough sleep, aircrew members must have the place (quiet, dark, and cool), the opportunity, and the correct training, i.e., proper scheduling and adaptation to changes in circadian rhythms. A sleep discipline policy would be a most important consideration for night flyers to ensure that they get adequate amounts of restful sleep.

In addition to the generalized fatigue experienced by aircrew, the use of NVG produces other types of fatigue. Visual fatigue, asthenopia or eye strain, can be minimized by: 1) wearing properly prescribed spectacles,⁷⁰ 2) receiving good training, 3) maintaining good habits of NVG adjustment to relax accommodation, and (4)

controlling sources of interfering light and reflections. Psychological fatigue may be controlled by providing the flyers with the knowledge and skills required for the job and by sustaining their level of expertise through regular, recurrent training.

Physical fatigue is induced by the weight of the NVG on the head.⁵⁶ NVG add over 0.7 kg to the weight of the aircrew helmet and significantly shift the center of gravity. Fatigue and soreness of the neck and shoulder muscles affect aircrew performance. Physical fatigue from wearing NVG can be reduced by maintaining good physical fitness, strengthening neck muscles, maintaining an erect sitting posture, balancing the NVG with a counterweight, and ensuring proper helmet fit. Isometric exercises can be used to strengthen neck and shoulder muscles to reduce mission fatigue.

NVG ACCIDENTS AND EYE PROTECTION

Flying at night is inherently dangerous, especially for some NVG missions. Accident rates per 100,000 flying hours are greater for NVG missions compared to daytime flying, or even unaided night missions.⁷¹ U.S. Marine Corps (USMC) helicopter accident rates for FY 87-90 were 1.74 for day, 5.98 for night, and 23.5 for NVG missions.⁷² U.S. Army (USA) accident rate data for FY 90 (through 31 Jul 90) were 1.3 for day and 4.43 for night missions, of which 44% were NVG flights.⁷²

NVG accidents are usually severe and, like day accidents, tend to occur at low altitudes because of flight profiles. Mean altitudes of USA accidents were 119 ft, 95 ft, and 642 ft for NVG, day, and unaided night missions, respectively.⁷² Sudden impact forces were reported in 20 of 27 USMC helicopter NVG accidents.⁷² Accidents that generate sudden-impact forces create excessive G-loading and ballistic hazards. A video tape provided by Ferranti International (United Kingdom) shows that sudden impact forces cause the NVG to swing like a pendulum and strike the ocular region with great force. In 12 of 27 USMC helicopter NVG accidents, bubble damage was sustained from bird/bat strike, wires, or impact with terrain or water.⁷² Sudden impact forces create flying debris and particles of Plexiglas.

Although a few anecdotal reports of minor eye injuries from aircraft accidents involving NVG have surfaced, there are no hard data relating to the incidence of eye injuries. Combined data from all U.S. military services revealed that only one eye injury has been officially reported from an NVG aircraft accident.⁷² No NVG-induced, nonfatal ocular injury has ever been reported to the Aeromedical Clinic at Headquarters, Air Force Special Operations Command (HQ AFSOC), Hurlburt Field, Florida. This lack of hard data may be misleading, however, because NVG accidents usually result in multiple severe injuries or fatalities. In 11 of 27 USMC helicopter NVG accidents, multiple extreme impact injuries and/or significant head trauma were reported.⁷² Accident investigators do not specifically look for and record eye injuries. We simply do not know, from the data, whether eye injuries were present. However, the potential is obviously there.

Eye protection is not required for emmetropic (nonspectacle-wearing) or contact-lens-wearing aircrew members when they fly on NVG missions. The standard

helmet-mounted visor, which is required for eye protection during low-level daytime flying, cannot be worn with NVG.⁶⁴ A study conducted by the USAF School of Aerospace Medicine (now Armstrong Laboratory) Ophthalmology Branch, found that 27.4% of USAF pilots, 51.5% of navigator/weapons system officers, and 40.1% of other aircrew have refractive errors that require visual correction. These spectacle-wearing aircrew members are also involved in aircraft accidents; e.g., 22% of USAF pilots and 40% of navigator/weapons system officers involved in aircraft accidents were spectacle wearers.⁷² Although spectacle wearers have some NVG eye protection, even wearing the standard lenses, they are authorized polycarbonate or 3-mm CR-39 (plastic) safety lenses for greater safety with NVG, in accordance with AFR 160-43, para 9-13. The regulation specifies that the safety lenses will be provided by the Armstrong Laboratory Optical Research Unit, Ophthalmology Branch (AL/AOCOP).

A recent NVG crash investigation revealed that, of 5 spectacle-wearing crewmembers aboard, none were wearing the appropriate safety lenses.^{54,56} Safety lenses will provide protection and prevent the possibility of the NVG tubes shattering the spectacle lenses during accidents or being damaged when flipping them down from the stowed position. A USA study,⁷³ done at Fort Rucker, Alabama, found that NVG tubes shattered standard glass spectacle lenses with as little as 16 ft-lbs of energy, i.e., an impact force similar to walking briskly into a wall. By comparison, 3-mm CR-39 lenses are 4 to 5 times more impact resistant, and 2.2-mm polycarbonate lenses are 50 to 100 times more impact resistant. Spectacles alone, however, do not provide complete protection from flying debris, dust, or windblast. The following recommendations may save aviators from eye injury.

1. Ensure that spectacle-wearing aircrew members receive and wear the proper safety lenses when flying on NVG missions.

2. Provide a set of plano safety lenses in the standard aircrew frame, on an optional basis, to emmetropic (nonspectacle-wearing) and contact lens-wearing aircrew.

3. As a short-term fix, make available these two alternatives for eye safety to provide protection from flying debris, windblast, and dust.

- a. The standard USA sun, wind, and dust goggle (NSN 8465-01-004-2893) may be effectively worn by some aircrew. It is compatible with spectacles, but the large eye relief may reduce the NVG field of view by as much as 25%. The standard clear acetate lens should be replaced by the ballistic class 3, clear, polycarbonate lens (NSN 8465-01-109-3997). A tinted protective lens is also available (NSN 8465-01-109-3996).

- b. The Gentex polycarbonate visor (N00019-88-C-0330) has a "step-in" design to fit snugly with the HGU-55P helmet. Although this visor is compatible with the ANVIS and AN/PVS-5, it reduces the NVG field of view by 10-20% and fogging has been a problem. It comes in a version that is compatible with spectacles.

4. A long-term fix is needed to address the issue of ocular protection for NVG users in all types of aircraft.

ACKNOWLEDGMENTS

The authors received help from many people in preparing, reviewing, and revising this manual. We thank the following people for their significant assistance: Dr Lee Task, Lt Col Mel O'Neal, Jeff Craig, and Mary Donohue-Perry from Armstrong Laboratory at Wright-Patterson AFB, OH; Col Bill Berkley, Dr Chuck Antonio, Dr Carita DeVilbiss, and Capt George Fiedler from Armstrong Laboratory at Williams AFB, AZ; Major John Kotulak, Dr Bill McLean, and Dr Rodger Wiley from the US Army Aeromedical Research Laboratory at Fort Rucker, AL; Col Dick Jones from the Surgeon General's Office at Bolling AFB, DC; Cdr Mike Middleman and LCdr Dave Still from the Naval Aerospace Medical Research Laboratory at Pensacola, FL; Col Robert Green, Col Dick Dennis, Col Doug Ivan, and Capt Ric Peterson from the Armstrong Laboratory at Brooks AFB, TX. Also, we offer special thanks to Ms Margie Lee for typing, and to Mr Tom Kerns for editing this document.

REFERENCES

1. Pedron MR. Seeing better in the dark. *Aviation Digest* 1:90-4, 26-27, Jul/Aug 1990.
2. Berkley W, Fiedler G. ANVIS adjustment procedures and course guide. Armstrong Laboratory, Aircrew Training Research Division, Williams AFB, Arizona, November 1991.
3. Mittelman M, Still D. Unaided Night Vision Training Guide. Naval Aerospace Medical Institute and Naval Aerospace Medical Research Laboratory, May 1990.
4. Wiley RW, Holly FF. Vision with the AN/PVS-5 night vision goggles. AGARD presentation, U.S. Army Aeromedical Research Laboratory, Ft Rucker, Alabama, April 1976.
5. Berkley W. A new test for preflight evaluation of NVG. Presented to the Aerospace Medical Association Scientific Program, Cincinnati, Ohio, May 1991.
6. Operator's Manual. Night Vision Goggles. NSN 5855-00-150-1820, HQ Department of the Army, Washington D.C., October 1981.
7. Antonio JC, Mason RP. Night vision devices. Published in U.S. Navy Flight Surgeon Manual, chapter 5, September 1990.
8. Guyton AC. *Textbook of Medical Physiology*. Philadelphia: W.B. Saunders Co., 5th edition, chapters 58, 59 and 60, 1976.
9. Records RE. *Physiology of the Human Eye and Visual System*. Hagerstown: Harper & Roe, 1979.
10. *Adler's Physiology of the Eye: Clinical Application*. 6th edition. Robert A. Moses, ed. St Louis: C. V. Mosby Co., 1975.
11. Rushton WAH. Visual adaptation. *Proceedings of the Royal Society of London* 162:20-46, 1965.
12. Miller RE II, Cosby O, Tredici TJ. Mesopic visual function in aircrew. *Aviat Space Environ Med Abstract* 57(55):508, May 1986.
13. Leibowitz HW. The human senses in flight. *Human Factors in Aviation*, chapter 4, pp. 83-117, 1988.

14. Berry W. Review of wartime studies of dark adaptation, night vision tests, and related topics. The Armed Forces National Research Council Vision Committee. Vision Committee Secretariat, University of Michigan, Ann Arbor, Michigan, August 1948.
15. Parker FW Jr. Studies on dark adaptation in military personnel complaining of "night blindness." *Arch Ophthalmol* 35:555-571, 1946.
16. Miller RE II. Operational Aspects of night vision in Aerospace Ophthalmology. *The Flight Surgeon's Handbook*, chapter 8. USAF School of Aerospace Medicine, Brooks AFB, Texas, July 1990.
17. Tredici TJ. Ophthalmology in aerospace medicine. *Fundamentals of Aerospace Medicine*, chapter 15, pp. 465-510. Roy L. DeHart, ed. Philadelphia: Lea and Febiger, 1985.
18. Carr CJ, Fisher KD. A study of individual variability in dark adaptation and night vision in man. Life Sciences Division, U.S. Army Research Office of the Chief, R&D, Department of the Army, Washington D.C., December 1970.
19. Pitts DG. Dark adaptation and aging. *J Am Opt Assoc* 53(1):37-41, January 1982.
20. Night vision: Current research and future directions. Symposium Proceedings, Committee on Vision, National Research Council. National Academy Press, Washington D.C., 1987.
21. Tredici TJ, Miller RE II. Night Vision Manual for the Flight Surgeon. USAFSAM-SR-85-3, Brooks AFB, Texas, August 1985.
22. Miller RE II. Techniques to enhance aerospace visual performance and classify aircrew. Proceedings of the Tri-Service Aeromedical Research Panel, Fall Technical Meeting, NAMRL, monograph 33, Pensacola, Florida, 13-14 November 1984.
23. Tipton DA. A review of vision physiology. *Aviat Space Environ Med* 55(2):145-149, 1984.
24. Night Vision Trainer. Department of the Air Force. AFR 50-10, June 1955.
25. *Night Systems Support, Volume 4: Human Factors. Interim Report.* National Systems Management Corporation, Alexandria, Virginia, November 1990.
26. Aeromedical Aspects of Vision and Visual Enhancement in Air Operations. United Kingdom report, Project Group 61/113, Appendix III to Annex G to Report of 30th Meeting of WP 61, Toronto, Canada, November 1990.

27. Smith HA, Goddard C. Effects of cockpit lighting color on dark adaptation. AFFDL-TR-67-56, Wright-Patterson AFB, Ohio, May 1967.
28. Task HL, Griffin LL. Electroluminescent lighting and other techniques for improving night vision goggles compatibility with cockpit displays. Presented at First Conference on Aviation Psychology, Ohio State University, Columbus, Ohio, April 1981.
29. Miller RE II, Tredici TJ. Aeromedical Aspects of Night Vision: Conference Proceedings. USAF School of Aerospace Medicine, Brooks AFB, Texas, June 1984.
30. Handy PB. Night vision training in the Canadian forces. Aeromedical and Training Digest, p. 14, January 1990.
31. O'Mara PA, Schmeisser ET, Weiss JF. Effects of supplementary vitamins and stimulants on dark adaptation. No. 83-44TN, Letterman Army Institute of Research, Presidio of San Francisco, California, March 1983.
32. Dyer FN. Smoking and soldier performance: A literature review. USAARL Report No. 86-13, Ft Rucker, Alabama, June 1986.
33. Rankowski JF. Night vision imaging systems: A primer. AEL Defense Corporation, prepared for the U.S. Army Communications-Electronics Command, Ft Monmouth, New Jersey, February 1989.
34. Miller RE II. Night vision goggles: Aeromedical issues. Report on the Joint Services Night Vision Conference, Department of the Army, St Louis, Missouri, August 1989.
35. Joint Service Night Vision Goggle Safety Conference Minutes. HQ USAF Inspection and Safety Center, Norton AFB, California, March 1986.
36. Night Vision 90. The 2nd Major International Night Vision Conference and Exhibition, London, England, August 1990.
37. Verona RW, Rash CE. Human factors and safety considerations of night vision systems in flight. USAARL Report No. 89-12, Ft Rucker, Alabama, July 1989.
38. Berson EL, Rabin AR, Mehaffey L. Advances in night vision technology: A pocketscope for patients with retinitis pigmentosa. Arch Ophthalmol 90:427-431, 1973.
39. Mason R. Doing it better in the dark. Aeromedical and Training Digest. pp. 14-18, January 1990.

40. Task HL, Hartman RT, Zobel AR. New methods for night vision goggles test and evaluation. Wright-Patterson AFB, Ohio.
41. Field circular: Night operations. CACDA FC 90-1, U.S. Army Combined Arms Combat Developments Activity, Ft Leavenworth, Kansas, November 1985.
42. Miller RE II, Provines WF, Block MG, Miller JW, Tredici TJ. Comparative visual performance with AN/PVS-5A night vision goggles under starlight conditions. USAFSAM-TR-84-28, Brooks AFB, Texas, August 1984.
43. Genco LV. Night vision support devices human engineering integration. Air Force Aerospace Medical Laboratory, Wright-Patterson AFB, Ohio, March 1985.
44. Farr DF. Compatibility of the aviation night vision imaging systems and the aging aviator. Aviat Space Environ Med 60(10):B78-80 (supp), October 1989.
45. O'Neal MR, Miller RE II. Further investigation of contrast sensitivity and visual acuity in pilot detection of aircraft. AAMRL-TR-88-002, Wright-Patterson AFB, Ohio, January 1988.
46. Riegler JT, Whiteley JD, Task HL, Schueren J. The effect of signal-to-noise ratio on visual acuity through night vision goggles. AL/HSD, Wright-Patterson AFB, Ohio, March 1991.
47. Richmond JC. Survey of image quality criteria for passive night vision devices. Law Enforcement Standards Program No. 27000-00259, U.S. Department of Justice, Washington D.C., June 1974.
48. Richmond JC. Test procedures for night vision devices. Law Enforcement Standards Program, U.S. Department of Justice, Washington D.C., July 1974.
49. Miller RE II, O'Neal MR, Woessner WM, Dennis RJ, Green RP Jr. The prevalence of spectacle wear and incidence of refractive error in USAF aircrew. USAFSAM-TR-89-28, Brooks AFB, Texas, February 1990.
50. Miller RE II, Woessner WM, Dennis RJ, O'Neal MR, Green RP Jr. Survey of spectacle wear and refractive error prevalence in USAF pilots and navigators. Optometry and Vision Science 67(11):833-839, November 1990.
51. Miller RE II, Woessner WM, Wooley LM, Dennis RJ, Green RP Jr. Compatibility of night vision goggles and chemical warfare masks. USAFSAM-TR-89-3, Brooks AFB, Texas, March 1989.
52. Task HL. Apparent field of view versus eye relief. Presented to HSD/YA, Brooks AFB, Texas, November 1991.

53. Donohue-Perry MM, Riegler JT, Hausman MA. A compatibility assessment of the protective integrated hood mask with ANVIS night vision goggles. AAMRL-TR-90-030, Wright-Patterson AFB, Ohio, July 1990.
54. Heitmeier LT. Night vision goggles: An aircrew enhancement? TIG Brief 42(4):12, Jul/Aug 1990.
55. Wiley RW, Glick DD, Bucha CT, Park CK. Depth perception with the AN/PVS-5 night vision goggles. USAARL Report No. 76-25, Ft Rucker, Alabama, July 1976.
56. Hammer DL. Night vision issues in 23rd Air Force. Point Paper to USAFSAM, Brooks AFB, Texas, May 1987.
57. Wiley RW. Visual acuity and stereopsis with night vision goggles. USAARL Report No. 89-9, Ft Rucker, Alabama, June 1989.
58. Walker DB, Dill R. Operation test and evaluation: Night vision goggles operations on unpaved surfaces. MAC Project 15-75-83, Final Report, Military Airlift Command, April 1983.
59. Shipley T. Thresholds and resolution in human vision: A new approach to night vision testing. Human Factors 16(1):56-64, February 1974.
60. Sheehy JB, Wilkinson M. Depth perception after prolonged usage of night vision goggles. NADC-86150-60, Naval Air Systems Command, Washington D.C., November 1986.
61. Sheehy JB, Wilkinson M. Depth perception after prolonged usage of night vision goggles. Aviat Space Environ Med 60:573, 9 June 1989.
62. Miller RE II, Kent JF, Green RP Jr. Prescribing spectacles for aviators. USAFSAM-SR-89-5, Brooks AFB, Texas, September 1989.
63. Walsh DJ. Laser protection with image-intensifier night vision devices. USAARL Report No. 90-3, Ft Rucker, Alabama, February 1990.
64. Miller RE II. Controversies in Aerospace Ophthalmology: Ocular Protection for night vision goggles wearers. Aviat Space Environ Med Abstract 61(5):452, May 1990.
65. Darrah MI, Seavers CR, Wang AJ, Dew DW. Acceleration loading tolerance of selected night vision goggle systems: A model analysis. McDonnell Douglas Corporation, St Louis, Missouri, 1986.

66. Review of the use of night vision goggles in flight training. Report for the Deputy Secretary of Defense, Department of Defense, July 1989.
67. Vos JJ, VanMeeteren A. PHIND: An analytical model to predict target acquisition distance with image-intensifiers. *Applied Optics* 30(8): 958-966, March 1991.
68. Levine RR, Rash CE. Visual acuity with AN/PVS-5A night vision goggles and simulated flashblindness protective lenses under varying levels of brightness and contrast. USAARL Report No. 89-16, Ft Rucker, Alabama, July 1989.
69. Krueger GP. Sustained work, fatigue, sleep loss and performance: A review of the issues. *Work and Stress* 3:129-141, 1989.
70. Miller RE II, Kent JF, Green RP Jr. Prescribing spectacles for USAF aviators. *Aviat Space Environ Med* 63:80-5, January 1992.
71. Miller RE II. USAF visual standards for night vision goggle users: The role of the flight surgeon. Report of the 5th Annual Joint Services Night Vision Conference, U.S. Army Aviation Systems Command, St Louis, Missouri, June 1990.
72. Miller RE II, Green RP Jr. Background paper on the need for eye protection for aircrew who wear night vision goggles. Report to USAF Surgeon General (HQ USAF/SGPA) and HSD/YA. Ophthalmology Branch, Armstrong Laboratory, Brooks AFB, Texas, December 1990.
73. Crosley JK. Polycarbonate ophthalmic lenses for ametropic Army aviators using night vision goggles. USAARL Report No. 88-12, Ft Rucker, Alabama, August 1988.

APPENDIX A

ANVIS

Adjustment Procedures



November 1991 (draft)

Armstrong Laboratory
Aircrew Training Research Division
Williams AFB, AZ

POC Capt George Fiedler DSN 474-6561

Night Vision Goggles Adjustment Procedures (ANVIS)

A. Introduction

Night vision goggles (NVGs) have become an integral part of night operations in many rotary- and fixed-wing aircraft. Properly fit and adjusted they dramatically enhance night vision. But the adjustment process is critical to obtaining optimal visual capability. Improper adjustment can severely degrade visual acuity. While NVGs are not hard to use, you need to understand their design characteristics to get the most out of them. This chapter presents the basics of NVG preflight adjustment procedures for the ANVIS system. These procedures can also be applied to other NVG systems.

B. NVG Components

ANVIS NVGs consist of three components: 1. the mount, 2. the battery pack, and 3. the binocular assembly.

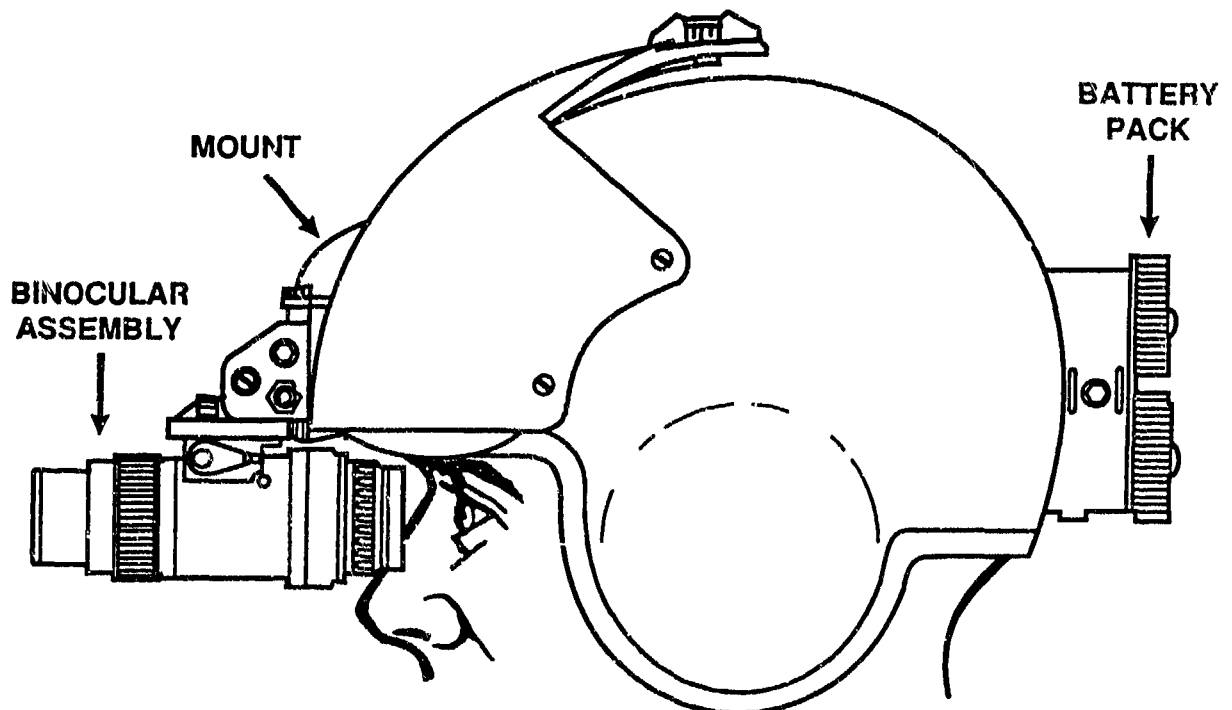

1. The mount is secured to the helmet and holds the binocular assembly in front of the eyes. It has three *important features*:
 - a. **Vertical adjustment knob** – moves the binocular assembly up and down.
 - b. **Lock release button** – facilitates rotation of the goggles from stowed position to operating position, and helps in removing the binocular assembly from mount.
 - c. **Low battery indicator** – provides warning of impending battery failure.

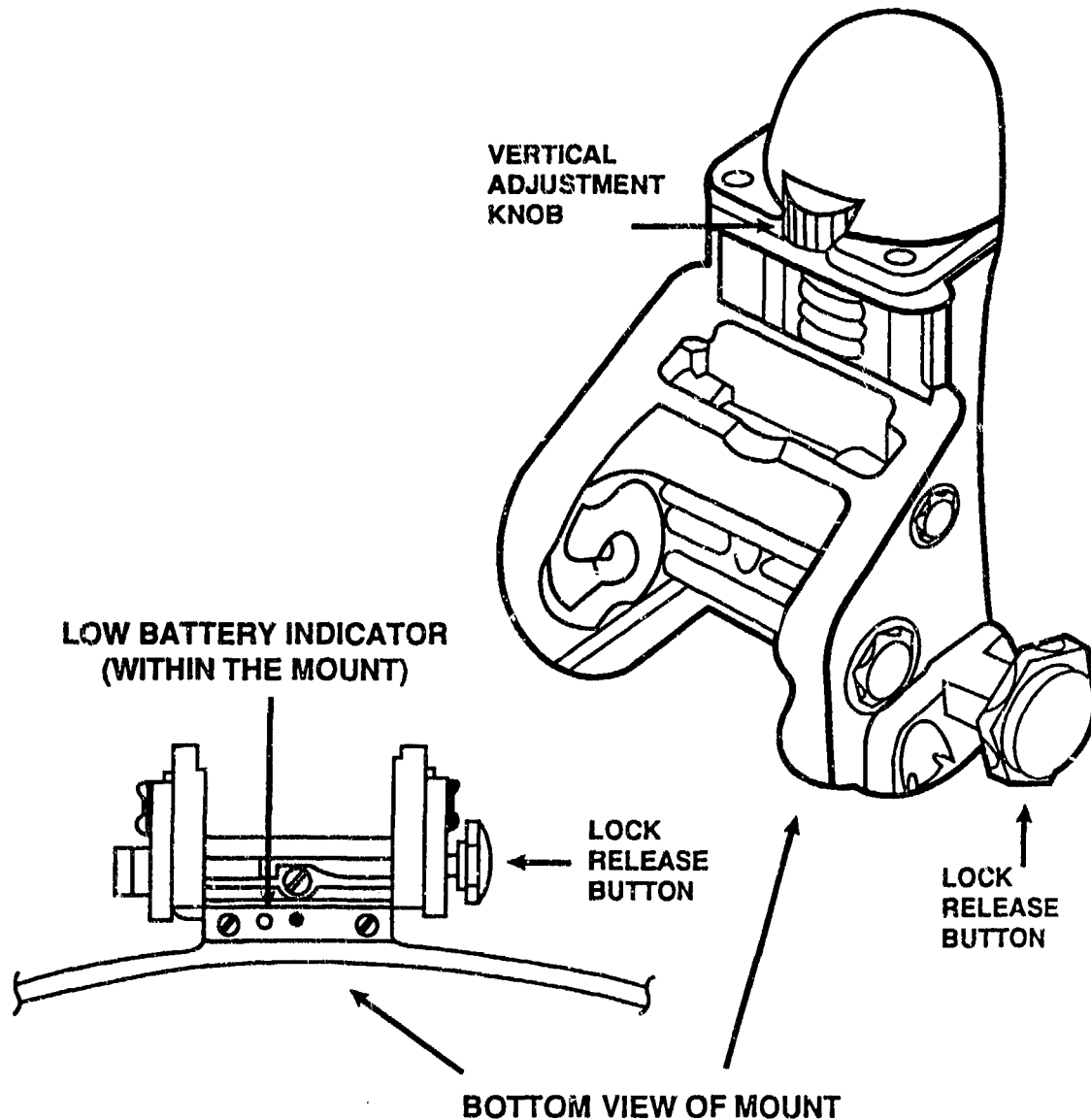

2. The battery pack powers the device and can be used with either AA penlight batteries or lithium batteries. Remember the following facts about the battery pack:
- Loading batteries** – Lithium batteries are inserted with the positive side up, while AA batteries go in positive side down.
 - Switching battery power** – The battery pack has a three-position switch. The OFF position is in the middle with UP and DOWN positions for the two battery compartments. ANVIS goggles operate on the battery or batteries which correspond to the switch position, thus providing an internal spare in the system.
 - Handling batteries** – Lithium batteries contain toxic substances and can vent or explode if handled improperly. Never carry spare batteries in pockets with other potential conductors, particularly keys or spare change.

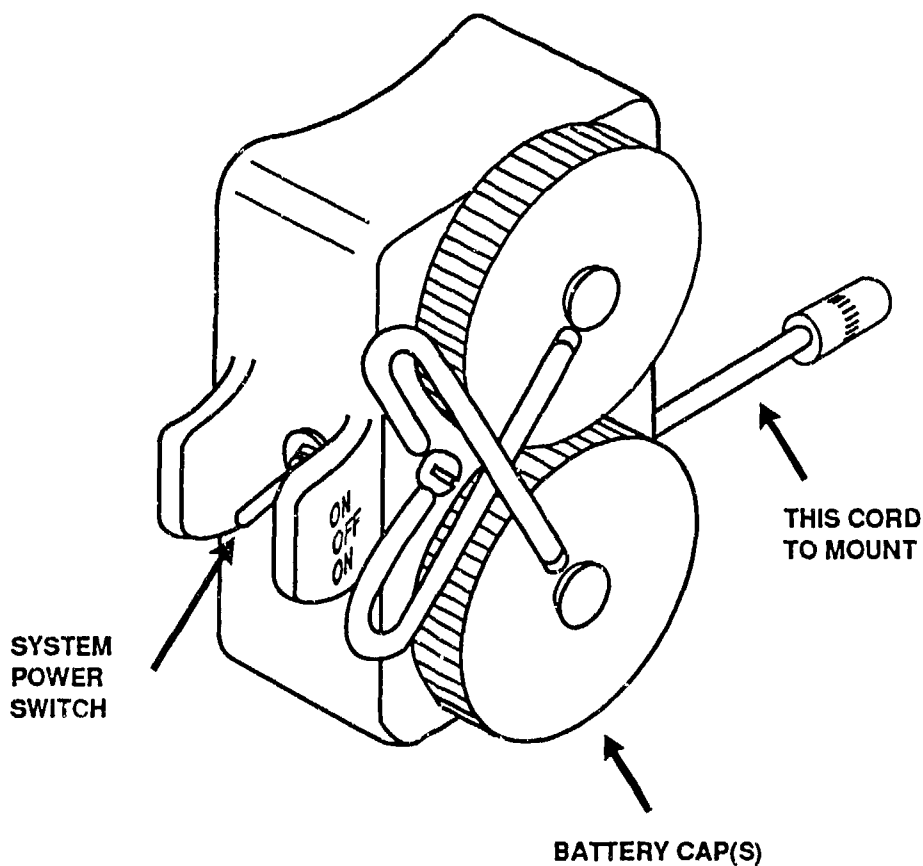

3. The binocular assembly contains the optical elements of the system. This component has several adjustment features. Learning to operate each feature is essential for proper alignment of the device. The following is a list of adjustment features on the binocular assembly:
- a. **Fore and aft adjustment knob** – moves the entire binocular assembly toward or away from the eyes.
 - b. **Tilt adjustment knob** – allows wearer to rotate the binocular assembly.
 - c. **Interpupillary distance (eyespan) adjustment knob** – allows wearer to adjust for the distance between the eyes.
 - d. **Objective focus ring** – focuses the goggles for distance (adjustment range is from 10 inches to infinity).
 - e. **Diopter focus ring** – compensates for individual refractive error.

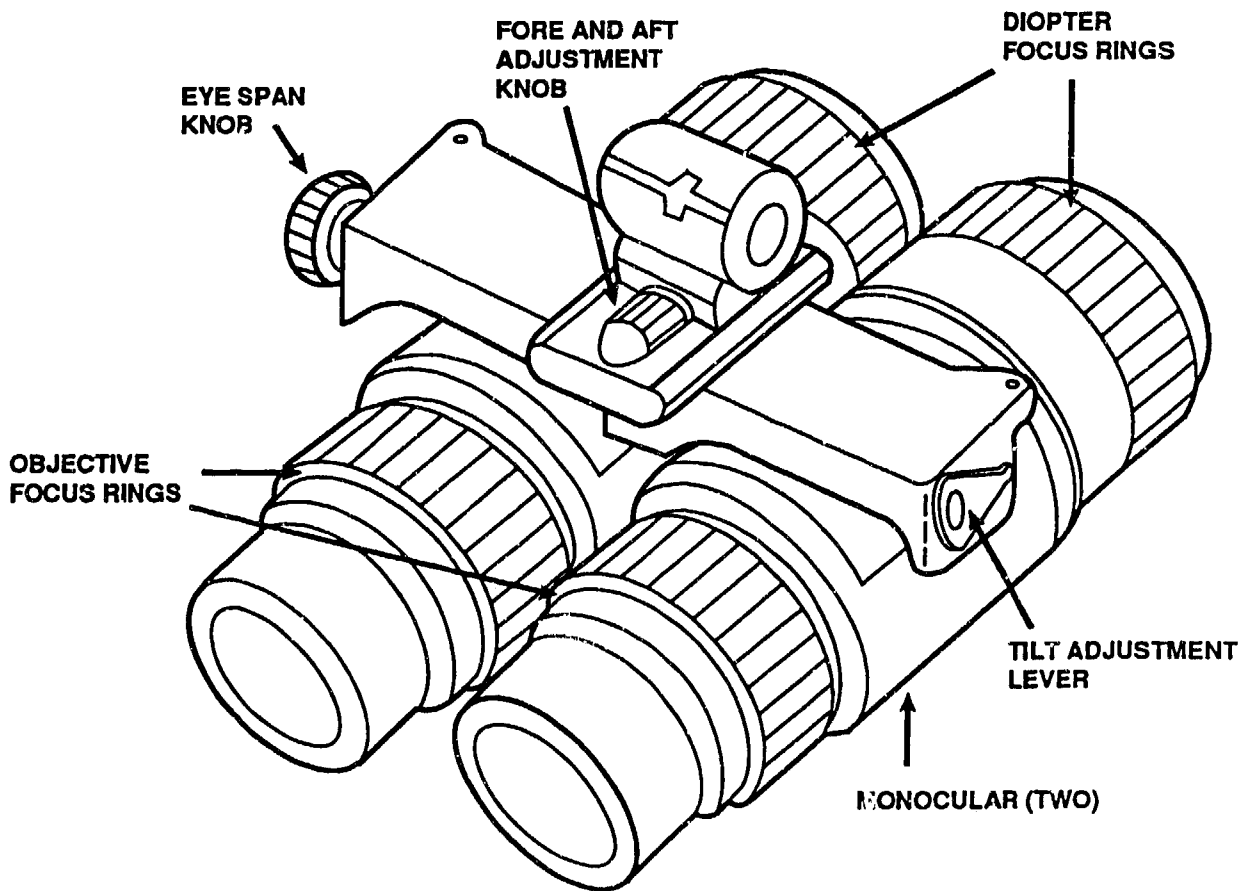

C. Preflight Procedures

Before flying with NVGs a series of alignment and focusing procedures must be performed to verify proper fit and function of the device. Remember: proper alignment of the optics is critical to achieving the best possible visual acuity from the equipment.

Perform the following procedures prior to donning the NVGs in the Test Lane:

1. **INSPECT DEVICE** -- Check the overall condition and security of the goggles.
 - a. Make sure all the knobs work properly.
 - b. Check for loose parts.
 - c. Check for frayed wiring.
2. **CLEAN LENSES** -- Inspect and clean the lenses if needed. Always use lens paper to prevent scratching the lens surfaces. Dirty optics can degrade performance by up to 30%*.
3. **SET IPD** -- Set your interpupillary distance (IPD) using the scale on the front of the goggle frame. The flight surgeon or life support personnel should be able to measure your IPD, if you don't know it.

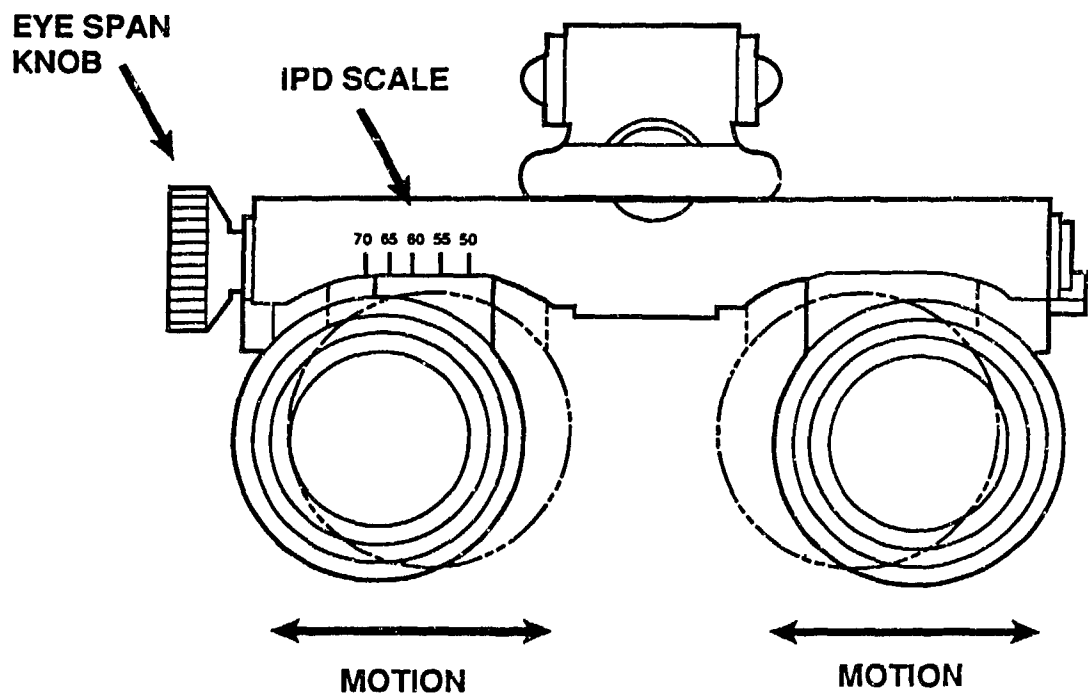

*As measured in the NVG Test Lane at the Armstrong Laboratory, Williams AFB, AZ.

4. **SET DIOPTER** – Set the diopter adjustment to your individual setting, if known. If you do not know your diopter settings, set them at zero.

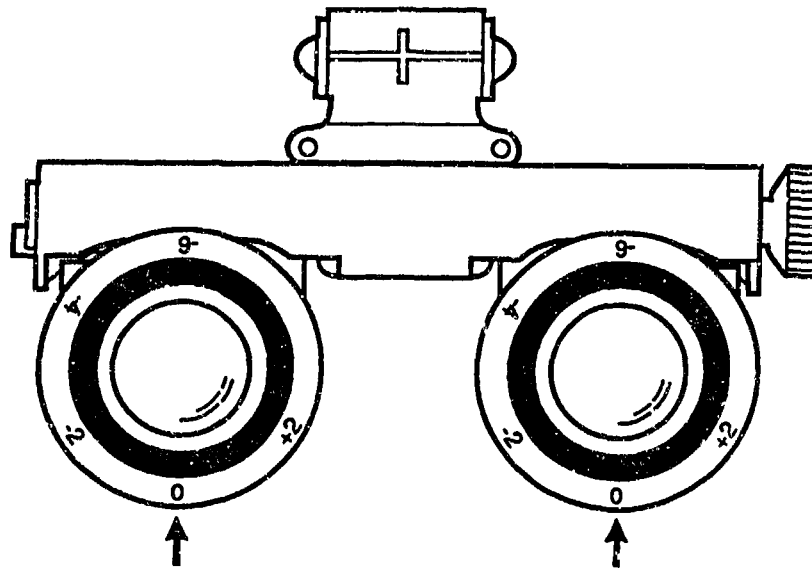

5. **ADJUST EYE RELIEF** – Position the binocular assembly as far forward (away from the eyes) as possible.

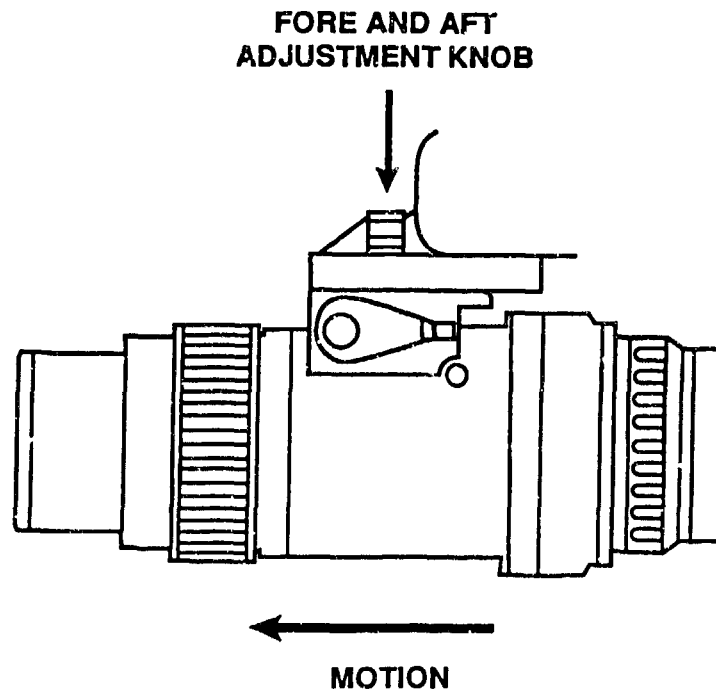

6. CENTER TILT – Set the tilt adjustment to the centered position.

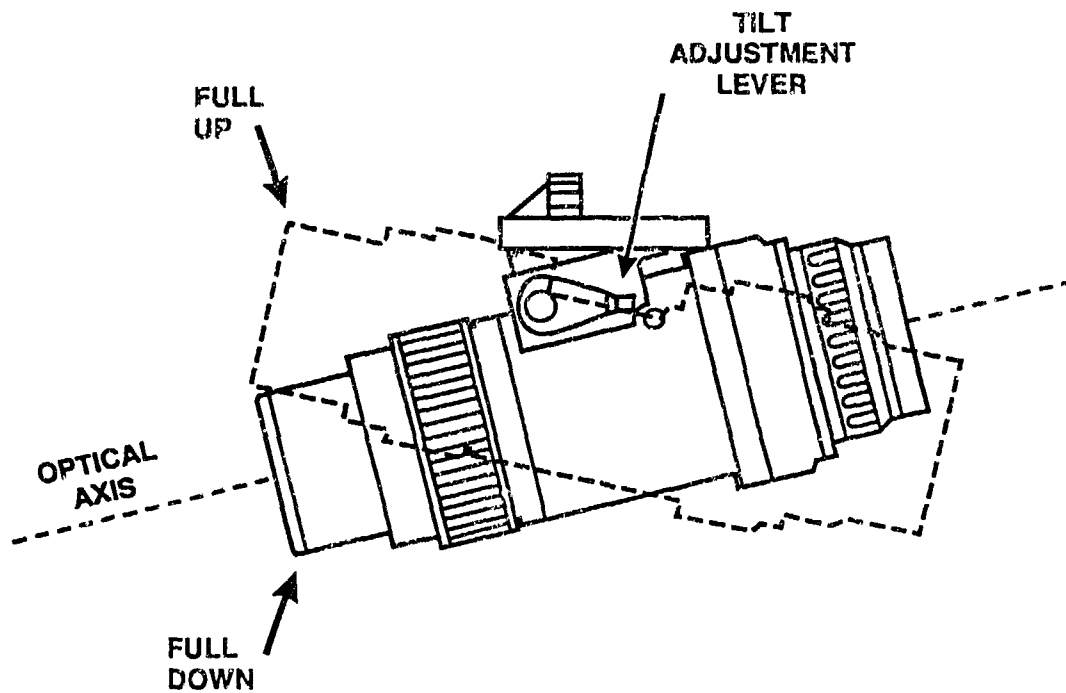

7. ADJUST VERTICAL – Set the mount to a position approximately one-third of the distance from its lowest limit.

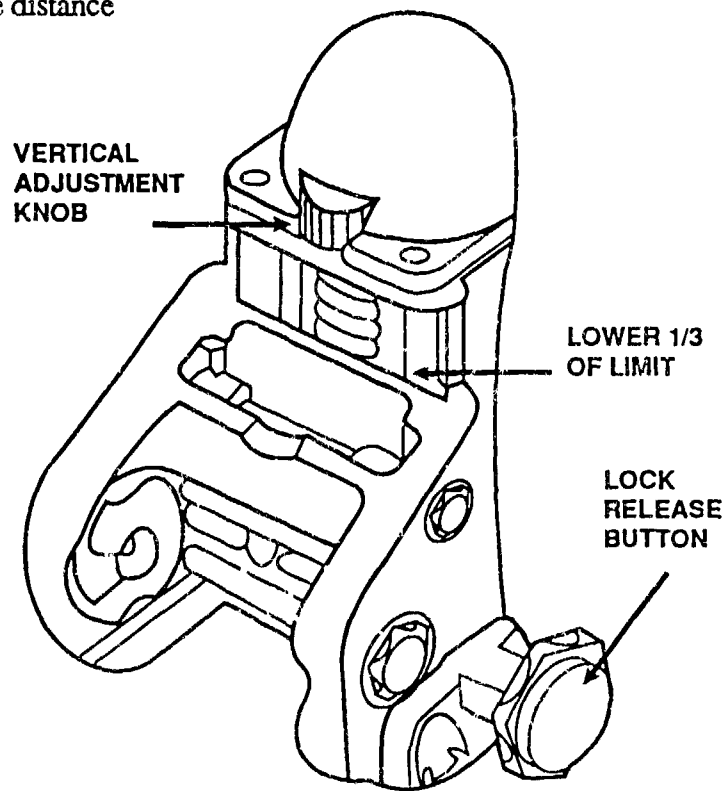

8. **ATTACH MOUNT** – Attach the helmet mount at the appropriate location. Life support personnel can help you determine the proper mount type and placement.
9. **LOAD BATTERY PACK** – Load the battery pack (with batteries) and connect it to the mount. The pack should be attached to the Velcro on the back of the helmet. Confirm that the switch is in the OFF position.

Now you are ready to proceed to the Test Lane. This may seem like a long list; but with experience, it will only take a few moments.

The purpose of using the NVG Test Lane is two-fold. First, it provides a place to align and focus your NVGs. Second, it checks the resolution capability of the device itself. Test Lane procedures are divided into: (1) alignment procedure, and (2) focusing procedure.

Alignment procedure is necessary because the design of the NVG provides the best performance **ONLY** when the device is aligned with the visual axis of the eye. The alignment procedure should be performed *before* the focusing procedure to prevent degradation in visual acuity caused by alignment errors.

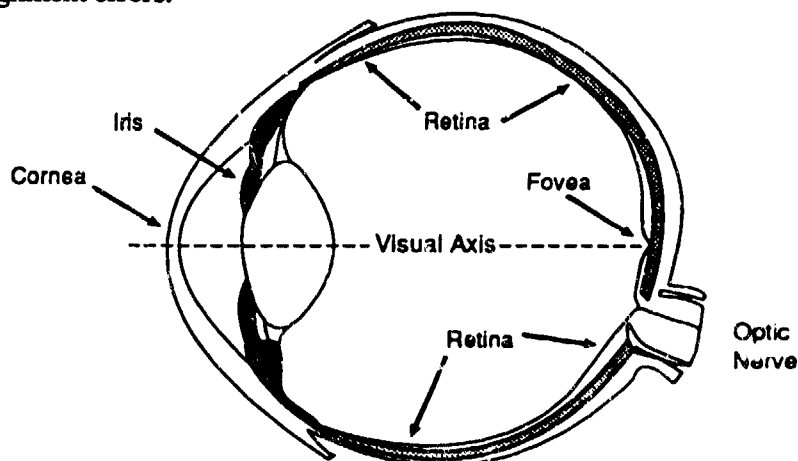

Once you are in the test lane with your helmet and NVGs donned, turn the lights off. Now you can turn on the NVGs.

CAUTION

**DO NOT TURN ON NVGs IN LIGHTED AREAS.
DAMAGE TO IMAGE INTENSIFICATION TUBES WILL RESULT.**

D. Alignment Procedures

1. **ALIGN VERTICAL** – Adjust the vertical position of the binocular assembly using the vertical adjustment knob. The binocular assembly should be directly in front of the eyes.

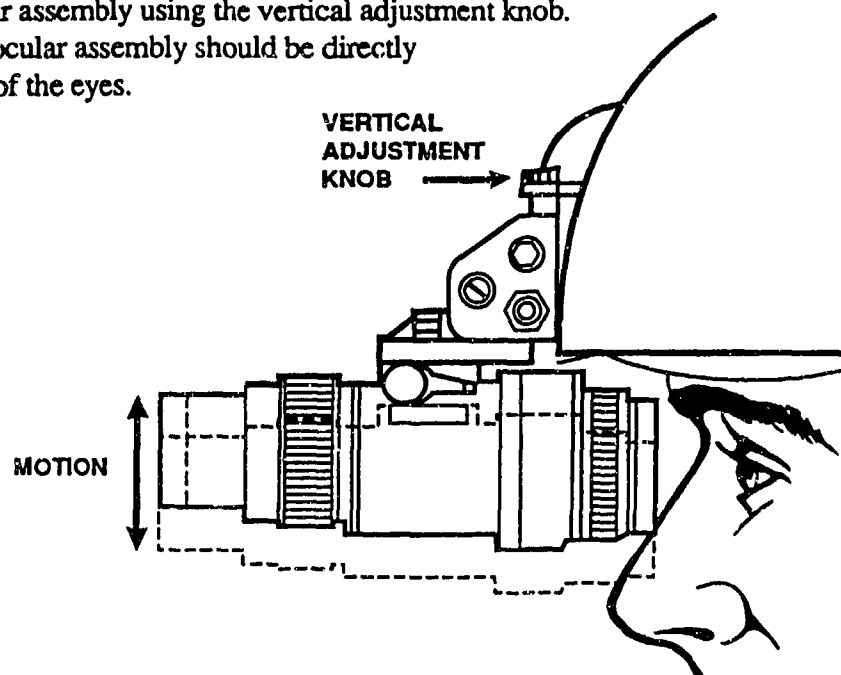

2. **ADJUST TILT** – Adjust the tilt so the binocular assembly is perfectly aligned with your visual axis. When the tilt is adjusted the binocular assembly is rotated. Therefore a corresponding vertical adjustment should also be made.

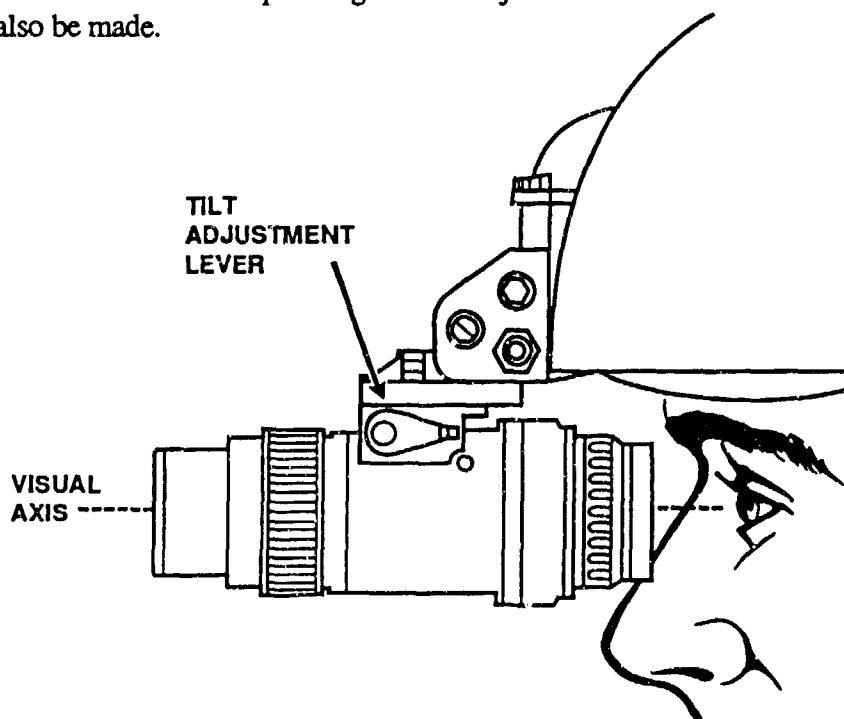

3. **CHECK IPD** – Confirm the setting of the interpupillary distance (IPD). When properly adjusted, the two images of the tubes overlap to form a single image. Each individual image is directly in front of the corresponding eye. It is important to note that improper adjustment of the interpupillary distance can cause loss of visual acuity, loss of depth perception and/or severe headache.

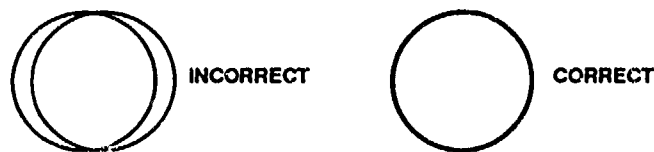

4. **ADJUST EYE RELIEF** – The device should be brought as close to the eyes as possible without touching eyelashes or spectacles.

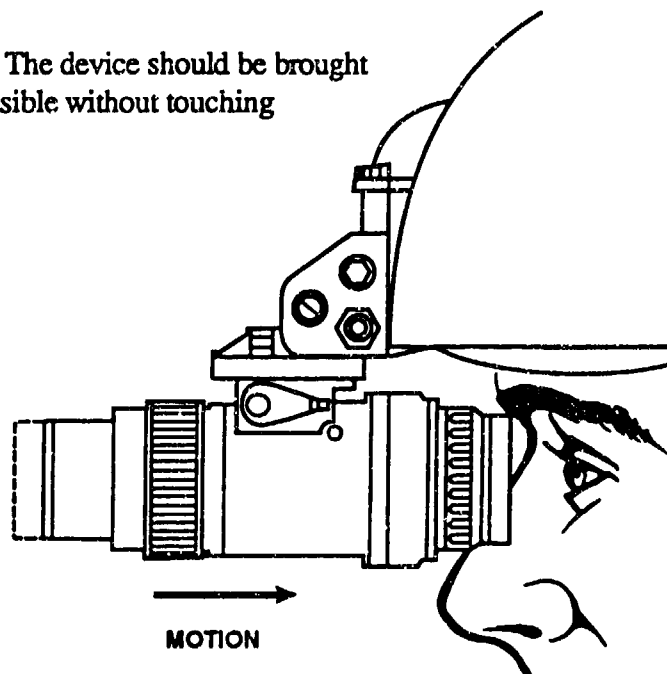

5. **EVALUATE PICTURE** – The NVG should be correctly aligned. There should be no shading in any part of the field of view. If there is, recheck mount positioning and angle. While performing the alignment procedures it may be helpful to evaluate each tube individually as well as together. Perfect alignment for each tube occurs when the objective lens circle is directly in the center of the eyepiece lens circle.

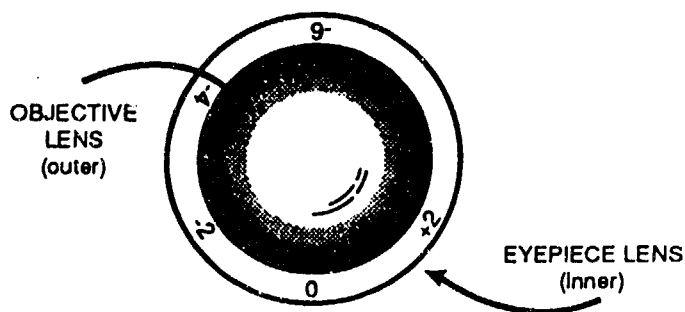

E. Focusing Procedures

Move to the 20 foot line in the Test Lane. Focus on the test patterns on the resolution chart as you adjust the goggles to get the sharpest focus. It is usually easier to start with the largest test patterns and fine-tune your way to the smaller patterns.

1. **FOCUS OBJECTIVE RING** – Since you are to focus one tube at a time, either close one eye or cover one of the tubes with a free hand. (Be careful not to touch the lens which you just cleaned.) Focus the objective (outer) ring until you can resolve as many of the patterns on the chart as possible.

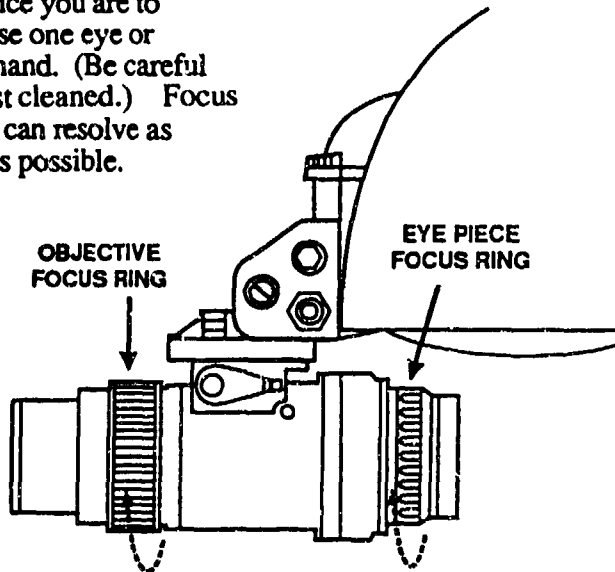

2. **FOCUS DIOPTER RING** – Fine tune the picture by rotating the diopter (inner) ring counterclockwise towards the positive until the picture is slightly blurred. Stop here and pause a second. Now, slowly rotate the ring back clockwise until the picture just becomes sharp. Do not rotate the knob beyond the setting which just sharpens the picture. If the diopter is turned too far, the eye muscles will initially accommodate for the overcorrection. However, over time they will become fatigued resulting in a loss of visual acuity, depth perception and/or headache.

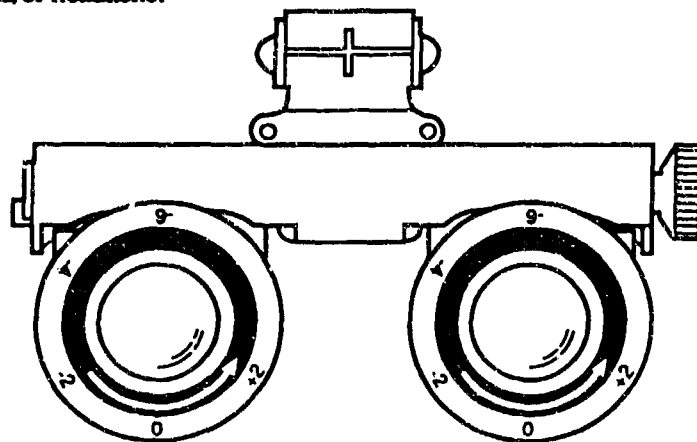

3. **REPEAT** steps 1 & 2. Focus the other tube using the same procedures. Do not be alarmed if one tube performs slightly better than the other. Differences frequently exist between the two tubes. The next step evaluates the overall performance of the goggles.

4. **CHECK PERFORMANCE** – From the 20 foot viewing distance, evaluate acuity with both eyes open. With ANVIS NVGs you should be able to resolve the pattern (i.e., see horizontal or vertical bars) in eight out of the nine test squares. If the goggles will not focus to this level of acuity, count the number of test patterns you can resolve and use the table below to determine acuity level. Acuity should be at least as good with both eyes as it is with the best tube.

# Correct	Visual Acuity	# Correct	Visual Acuity
9 of 9 ==>	20/35 or better	4 of 9 ==>	20/70
8 of 9 ==>	20/40	3 of 9 ==>	20/80
7 of 9 ==>	20/45	2 of 9 ==>	20/90
6 of 9 ==>	20/50	1 of 9 ==>	20/100
5 of 9 ==>	20/60	0 of 9 ==>	????

5. **NOTE SETTINGS** – Before leaving the Test Lane, note the IPD and diopter settings which are correct for you with this set of goggles. You will need to re-check these settings aboard the aircraft before donning the NVGs. This re-check ensures the settings were not accidentally changed during transport.

F. In-Aircraft Procedure

1. Before donning NVGs in the aircraft, confirm that the IPD and diopter settings are the same as those used in the Test Lane.
2. Since the device was focused at twenty feet in the Test Lane, you will need to re-focus to infinity (use only the objective focus knob). To re-focus, pick a clearly defined object at least 75-100 feet distant, preferably one with vertical edges or features. Avoid focusing on noncompatible lights because the halos they create are hard to focus on.
3. During flight you may need to make minor adjustments to vertical, tilt, and horizontal alignments due to helmet settling and rotation.

DO NOT CHANGE IPD OR DIOPTER SETTINGS DURING FLIGHT!

G. NVG malfunctions

Several types of NVG malfunctions exist. The most common types are as follows:

1. **SHADING** – appears as a dark area along the edge of an image. When shading is present, a fully circular image will not be seen with the malfunctioning tube when it is viewed separately. If shading is present, write up the malfunction and turn the device in for maintenance.
2. **EDGE GLOW** – appears as a bright area along the outer edge of the image. If you see this you must first rule out the possibility this is the result of some incompatible light source. Hold one hand in front of the objective lens. If it is still present, write up the malfunction and turn the device in for maintenance.
3. **BRIGHT SPOTS** – Constant or flickering spots anywhere in the image. Hold one hand in front of the objective lens. If bright spots are still present, write up the malfunction and turn the device in for maintenance.
4. **FLASHES/FLICKERING** – if more than one flash or flicker occurs, write up the malfunction and turn the device in for maintenance.

Some NVG malfunctions occur which are only grounding items when they become extreme. Evaluate the severity of these malfunctions as follows:

1. **HONEYCOMBING** – pattern in image most often seen in high light levels. If it occurs in a very dark environment a problem exists.
2. **DISTORTION** – optical bending of a viewed object. If it is present and excessive don't fly with them.
3. **VEILING GLARE** – caused by dirty, chipped, or scratched lenses which scatter light that strikes them at an angle. If it reduces visual acuity leave them behind.
4. **DARK SPOTS** – Evaluate for size and interference with vision. Don't fly with goggles that have large dark spots near the center of the image.

Any time you are uncertain about the operational capabilities of a pair of NVGs, have them checked by the local life support technicians.

Night Vision Goggles Adjustment Procedures (CATSEYE)

A. Introduction

Night vision goggles (NVGs) have become an integral part of night operations in many rotary- and fixed-wing aircraft. Properly fit and adjusted they dramatically enhance night vision. But the adjustment process is critical to obtaining optimal visual capability. Improper adjustment can severely degrade visual acuity. While NVGs are not hard to use, you need to understand their design characteristics to get the most out of them. This chapter presents the basics of NVG preflight adjustment procedures for the CATSEYE system. These procedures can also be applied to other NVG systems.

B. NVG Components

CATSEYE NVGs consist of two components: the mount assembly and the binocular assembly.

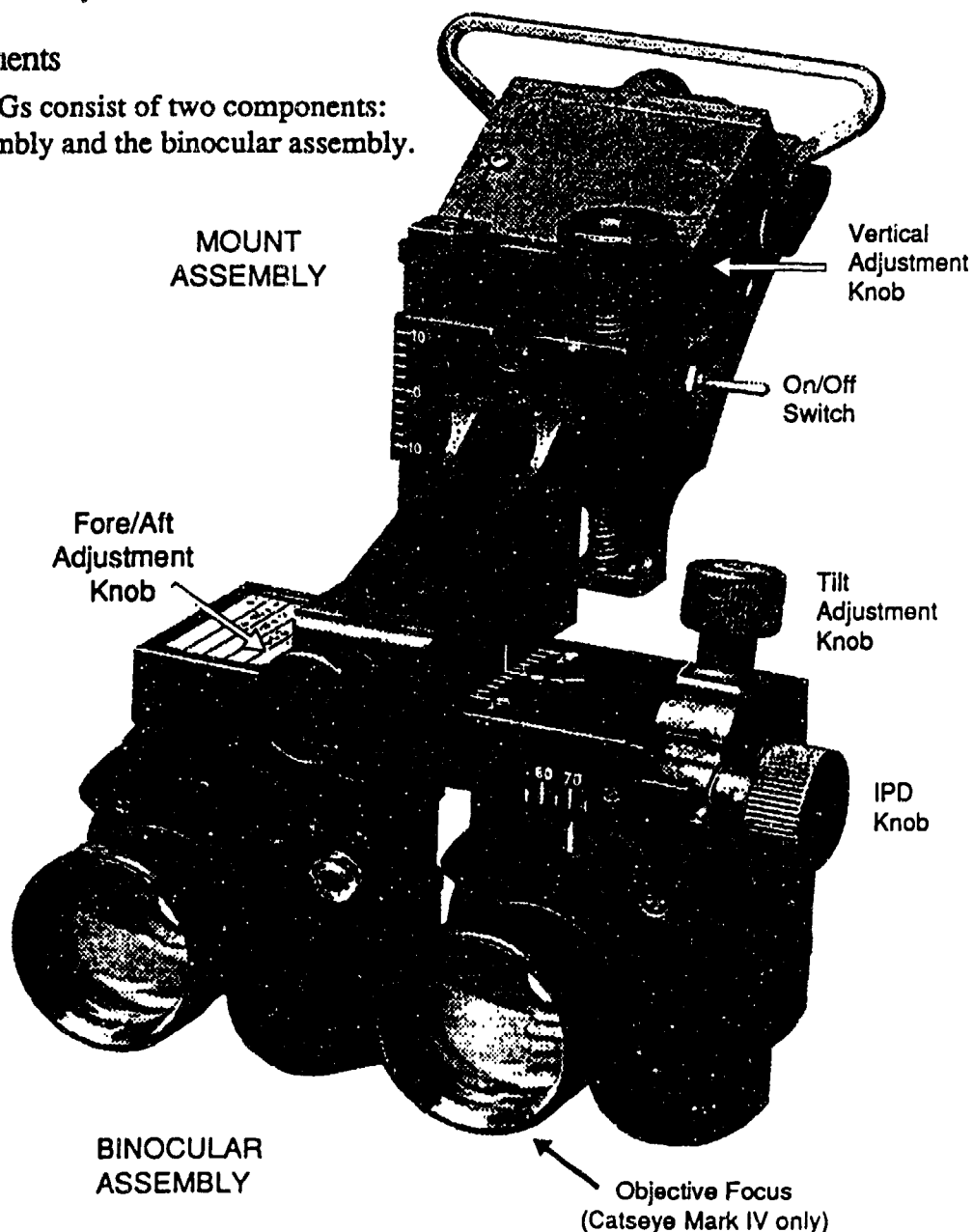

1. The mount assembly is secured to the helmet and holds the binocular assembly in front of the eyes.
 - a. **Vertical adjustment knob** – moves the binocular assembly up and down.
 - b. **Quick release lever** - used to release the goggles from the mount by grasping and pulling forward.
 - c. **Battery compartment** -
 - i. **Loading batteries** – Lithium batteries are inserted according to the directions in the compartment.
 - ii. **Switching battery power** – The battery compartment has a three-position switch. The OFF position is in the middle with UP and DOWN positions for the two batteries. CATSEYE goggles operate on the battery corresponding to the switch position, thus providing an internal spare in the system.
 - iii. **Handling batteries** – Lithium batteries contain toxic substances and can vent or explode if handled improperly. Never carry spare batteries in pockets with other potential conductors, particularly keys or spare change.

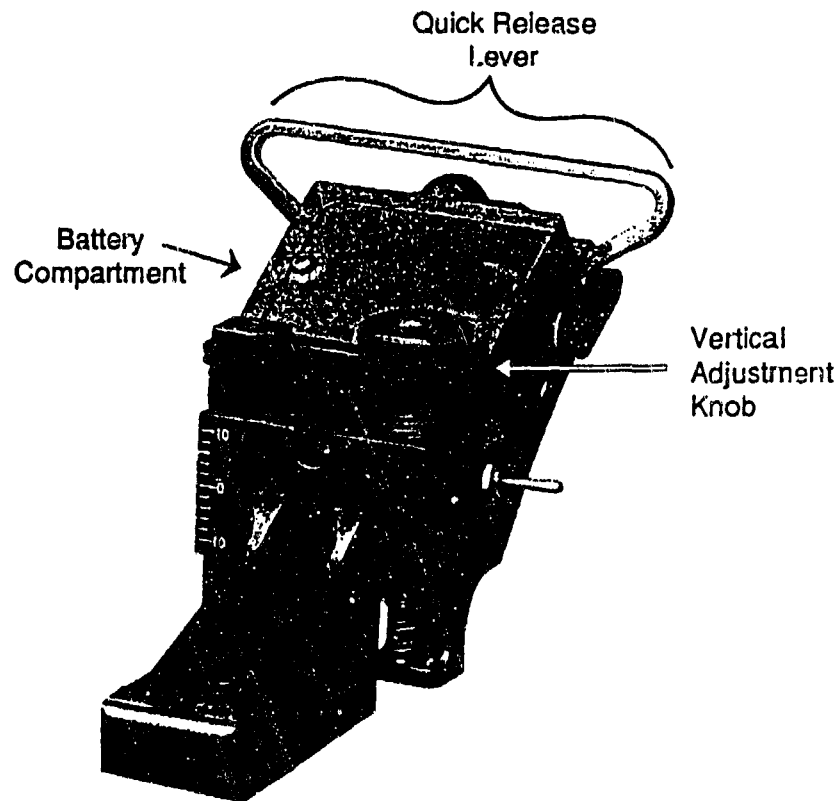

2. The binocular assembly contains the optical elements of the system. This component has several adjustment features. Learning to operate each feature is essential for proper alignment of the device. The following is a list of adjustment features on the binocular assembly:
- a. **Fore and aft adjustment knob** – moves the entire binocular assembly toward or away from the eyes.
 - b. **Tilt adjustment knob** – allows wearer to rotate the binocular assembly.
 - c. **Interpupillary distance (eyespan) adjustment knob** – allows wearer to adjust for the distance between the eyes.
 - d. **Objective focus ring** – (Catseye Mark IV only) focuses the goggles for distance.

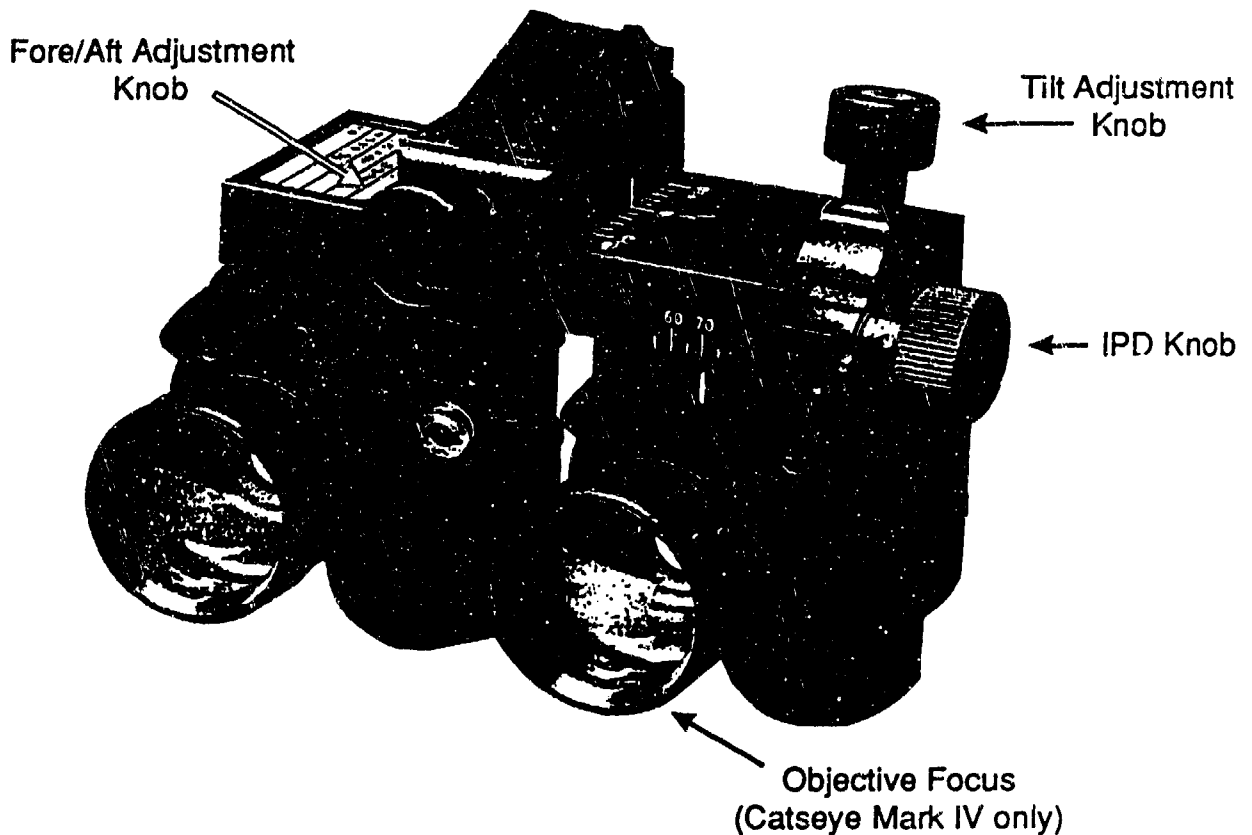

C. Preflight Procedures

Before flying with NVGs a series of alignment and focusing procedures must be performed to verify proper fit and function of the device. Remember: proper alignment of the optics is critical to achieving the best possible visual acuity from the equipment.

Perform the following procedures prior to donning the NVGs in the Test Lane:

1. **INSPECT DEVICE** – Check the overall condition and security of the goggles.
 - a. Make sure all the knobs work properly.
 - b. Check for loose parts.
 - c. Check for frayed wiring.
2. **CLEAN LENSES** – Inspect and clean the lenses if needed. Always use lens paper to prevent scratching the lens surfaces. Dirty optics can degrade performance by up to 30%.
3. **SET IPD** – Set your interpupillary distance (IPD) using the scale on the front of the goggle frame. The flight surgeon or life support personnel should be able to measure your IPD, if you don't know it.

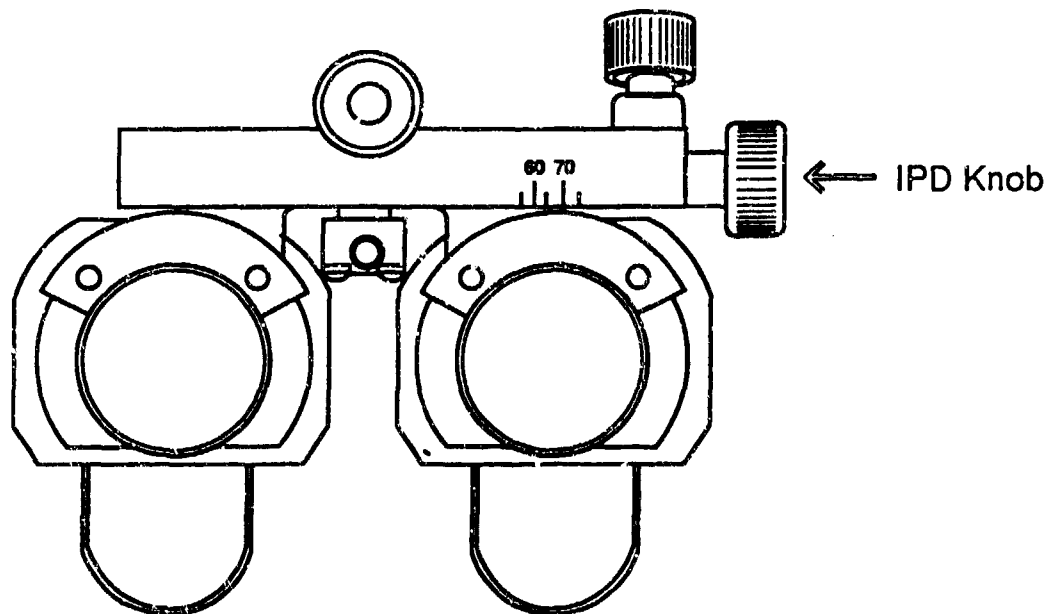

*As measured in the NVG Test Lane at the Armstrong Laboratory, Williams AFB, AZ.

4. **ADJUST EYE RELIEF** – Position the binocular assembly as far forward (away from the eyes) as possible.

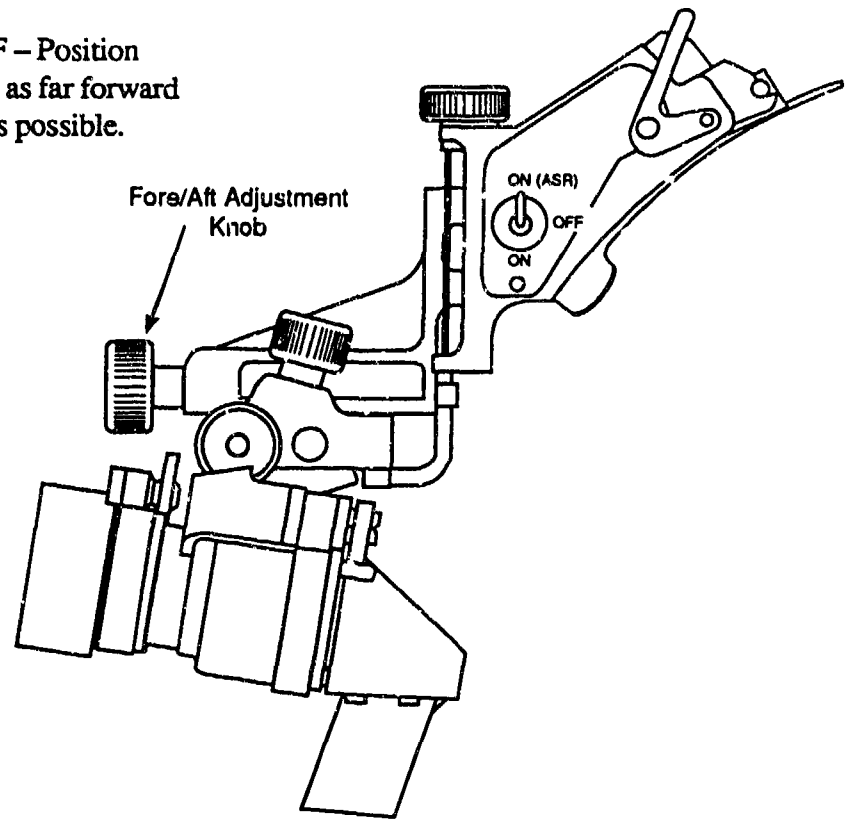

5. **CENTER TILT** – Set the tilt adjustment to the centered position.

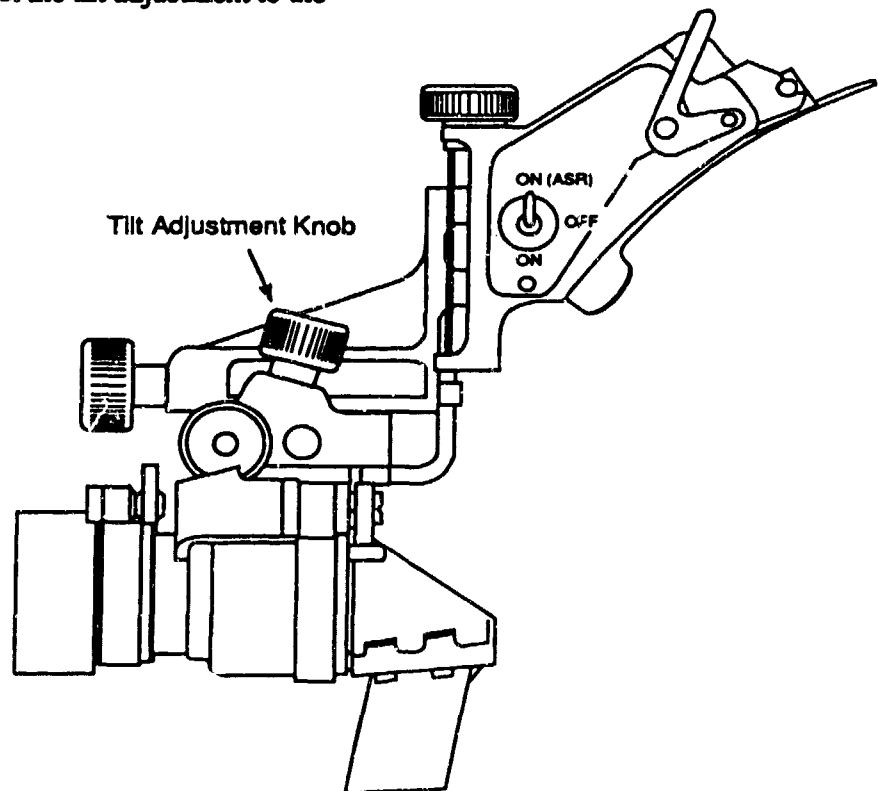

6. **ADJUST VERTICAL** – Set the binocular assembly to a position approximately one-third of the distance from its lowest limit.

7. **ATTACH MOUNT** – Attach the helmet mount at the appropriate location. Life support personnel can help you determine the proper mount type and placement.

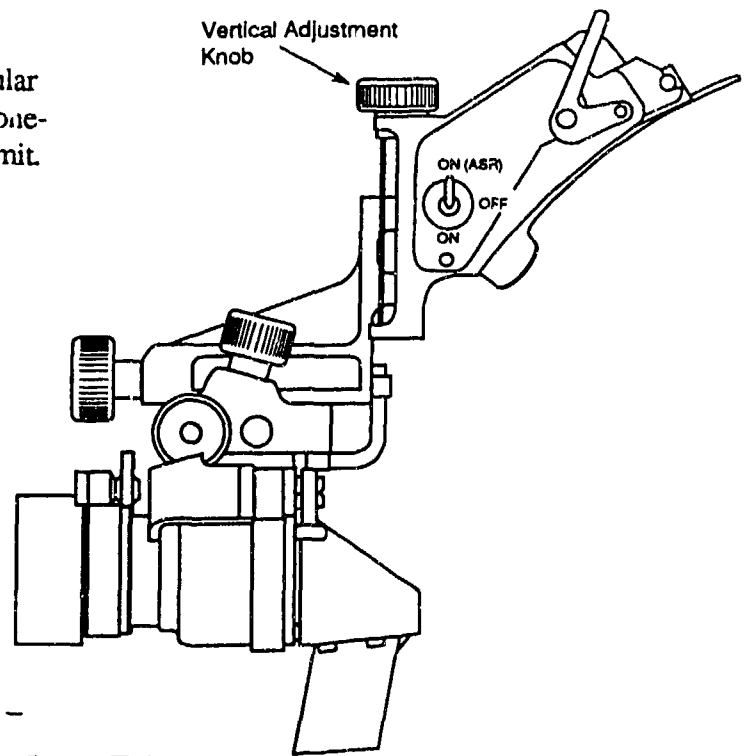

8. **LOAD BATTERY COMPARTMENT** –

Now you are ready to proceed to the Test Lane. This may seem like a long list; but with experience, it will only take a few moments.

The purpose of using the NVG Test Lane is two-fold. First, it provides a place to align and focus your NVGs. Second, it checks the resolution capability of the device itself. Test Lane procedures are divided into: (1) alignment procedure, and (2) focusing procedure.

Alignment procedure is necessary because the design of the NVG provides the best performance **ONLY** when the device is aligned with the visual axis of the eye. The alignment procedure should be performed *before* the focusing procedure to prevent degradation in visual acuity caused by alignment errors.

Once you are in the test lane with your helmet and NVGs donned, turn the lights off. Now you can turn on the NVGs.

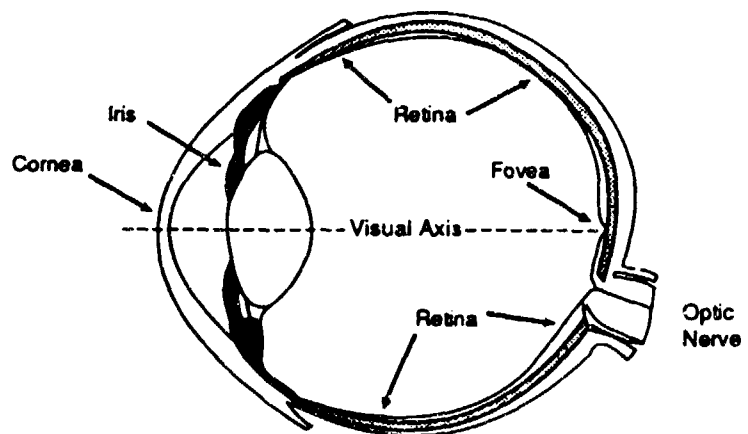

CAUTION

**DO NOT TURN ON NVGs IN LIGHTED AREAS.
DAMAGE TO IMAGE INTENSIFICATION TUBES WILL RESULT.**

D. Alignment Procedures

1. **ALIGN VERTICAL** – Adjust the vertical position of the binocular assembly using the vertical adjustment knob. The binocular assembly should be directly in front of the eyes.

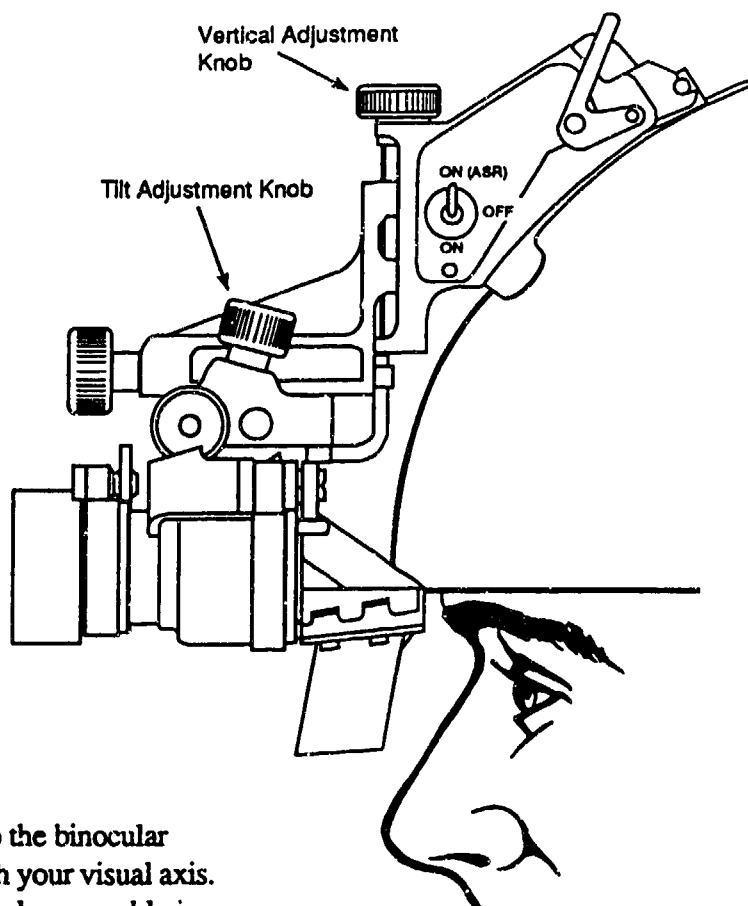

2. **ADJUST TILT** – Adjust the tilt so the binocular assembly is perfectly aligned with your visual axis. When the tilt is adjusted the binocular assembly is rotated. Therefore a corresponding vertical adjustment should also be made.
3. **CHECK IPD** – Confirm the setting of the interpupillary distance (IPD). When properly adjusted, the image should form a perfect circle when looking straight down the center of the tubes. Each individual image is directly in front of the corresponding eye. It is important to note that improper adjustment of the interpupillary distance can cause loss of visual acuity, loss of depth perception and/or severe headache.



CORRECT

4. **ADJUST EYE RELIEF** – The device should be brought as close to the eyes as possible without touching eyelashes or spectacles.
5. **EVALUATE PICTURE** – The NVG should be correctly aligned. There should be no shading in any part of the field of view. If there is, recheck mount positioning and angle.

Fore/Aft Adjustment Knob

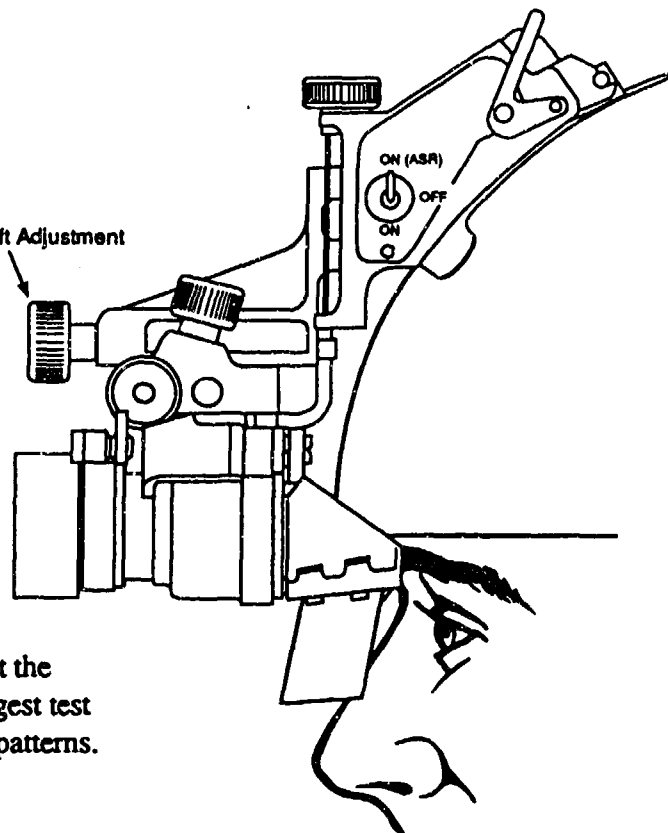

E. Focusing Procedures

Move to the 20 foot line in the Test Lane. Focus on the test patterns on the resolution chart as you adjust the goggles to get the sharpest focus. It is easiest to start with the largest test patterns and fine-tune your way to the smaller patterns.

– Catseye Mark III

1. Install corrective test lane lenses. This is necessary to focus the goggles at 20 feet.
2. With both eyes open, make minor adjustments to the tilt of the device to get the combiner at the perfect angle for the sharpest picture. This is the only way to fine-tune the picture.

– Catseye Mark IV

1. **Focus Objective Ring** - Since you are to focus one tube at a time, either close one eye or cover one of the tubes with a free hand. (Be careful not to touch the lens which you just cleaned.) Focus the objective (outer) ring until you can resolve as many of the patterns on the chart as possible.
2. With both eyes open, make minor adjustments to the tilt of the device to get the combiner at the perfect angle for the sharpest picture.
3. Repeat step 1. Focus the other tube using the same procedures. Do not be alarmed if one tube performs slightly better than the other. Differences frequently exist between the two tubes. The next step evaluates the overall performance of the goggles.

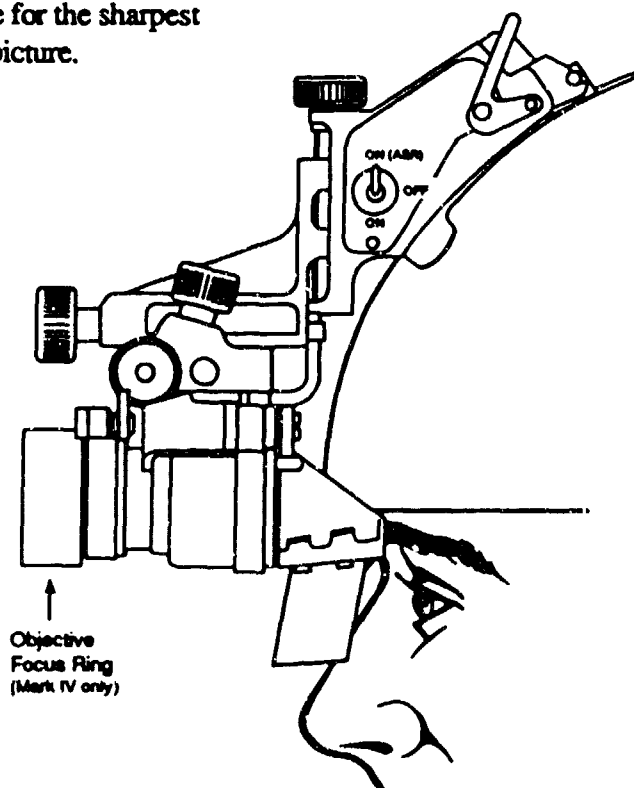

1. **CHECK PERFORMANCE** – From the 20 foot viewing distance, evaluate acuity with both eyes open. With CATSEYE NVGs you should be able to resolve the pattern (i.e., see horizontal or vertical bars) in eight out of the nine test squares. If the goggles will not focus to this level of acuity, count the number of test patterns you can resolve and use the table below to determine acuity level. Acuity should be at least as good with both eyes as it is with the best tube.

# Correct	Visual Acuity	# Correct	Visual Acuity
9 of 9 =>	20/35 or better	4 of 9 =>	20/70
8 of 9 =>	20/40	3 of 9 =>	20/80
7 of 9 =>	20/45	2 of 9 =>	20/90
6 of 9 =>	20/50	1 of 9 =>	20/100
5 of 9 =>	20/60	0 of 9 =>	???

2. **NOTE SETTINGS** – Before leaving the Test Lane, note the IPD setting that is correct for you with this set of goggles. You will need to re-check this setting aboard the aircraft before donning the NVGs. This re-check ensures the setting was not accidentally changed during transport.

F. In-Aircraft Procedure

1. Before donning NVGs in the aircraft, confirm that the IPD setting is the same setting used in the Test Lane.
2. Since the device was focused at twenty feet in the Test Lane, you will need to re-focus to infinity (Mark IVs only). To re-focus, pick a clearly defined object at least 75-100 feet distant, preferably one with vertical edges or features. Avoid focusing on noncompatible lights because the halos they create are hard to focus on.
3. During flight you may need to make minor adjustments to vertical, tilt, and horizontal alignments due to helmet settling and rotation.

DO NOT CHANGE IPD SETTING DURING FLIGHT!

G. NVG malfunctions

Several types of NVG malfunctions exist. The most common types are as follows:

1. SHADING – appears as a dark area along the edge of an image. When shading is present, a fully circular image will not be seen with the malfunctioning tube when it is viewed separately. If shading is present, write up the malfunction and turn the device in for maintenance.
2. EDGE GLOW – appears as a bright area along the outer edge of the image. If you see this you must first rule out the possibility this is the result of some incompatible light source. Hold one hand in front of the objective lens. If it is still present, write up the malfunction and turn the device in for maintenance.
3. BRIGHT SPOTS – Constant or flickering spots anywhere in the image. Hold one hand in front of the objective lens. If bright spots are still present, write up the malfunction and turn the device in for maintenance.
4. FLASHES/FLICKERING – if more than one flash or flicker occurs, write up the malfunction and turn the device in for maintenance.

Some NVG malfunctions occur which are only grounding items when they become extreme. Evaluate the severity of these malfunctions as follows:

1. HONEYCOMBING – pattern in image most often seen in high light levels. If it occurs in a very dark environment a problem exists.
2. DISTORTION – optical bending of a viewed object. If it is present and excessive don't fly with them.
3. VEILING GLARE – caused by dirty, chipped, or scratched lenses which scatter light that strikes them at an angle. If it reduces visual acuity leave them behind.
4. DARK SPOTS – Evaluate for size and interference with vision. Don't fly with goggles that have large dark spots near the center of the image.

Any time you are uncertain about the operational capabilities of a pair of NVGs, have them checked by the local life support technicians.

APPENDIX B

REPORT OF LITERATURE REVIEW: SMOKING AND NIGHT VISION

We recently conducted an in-depth search of the literature on the effects of smoking tobacco on night vision. While there has been much investigation, contradictions exist in the published studies. A very comprehensive review of the literature on smoking was published in June 1986 by United States Army Aeromedical Research Laboratory (USAARL), Ft Rucker, Alabama (1). One chapter in that review was devoted to the effects on vision, including night vision. In it, comparable studies were summarized that supported each of three possible positions, i.e., smoking degraded night vision, had no effect, or improved night vision. Although it was reported that sufficient evidence existed to argue against selection of smokers for military night missions, the most compelling conclusion in the review was that more research was needed to adequately resolve this controversy. More recent research (2, 3), however, failed to unequivocally resolve the controversy.

There are several factors that make investigation of the effects of smoking on night vision difficult. Night vision is, in itself, a complex physiological process. Visual function at night encompasses many parameters, e.g., scotopic dark adaptation, mesopic vision, contrast sensitivity, visual discrimination of moving targets, peripheral retinal sensitivity, glare recovery, and dark focus. The National Research Council Working Group on Night Vision, commissioned in 1984 by USAFSAM/NGO, was unable to adequately prioritize the relevant parameters in aerospace night vision (4). Thus, it is difficult to limit night vision testing to single, easy tests and still obtain operationally meaningful information.

Large variation in night vision performance exists among normal individuals (4). Thus intersubject differences in dark adaptation of less than one order of magnitude are usually considered clinically insignificant. Accordingly, studies of night vision must have large sample sizes in order to detect small but significant effects. Samples of smokers and nonsmokers must also be very carefully matched for age, because age correlates inversely with night vision (4).

The effects of smoking are different for nonsmokers versus smokers versus deprived smokers. When a nonsmoker smokes a cigarette, heart arrhythmias, nausea, and emesis may occur (5). Smokers, on the other hand, experience pleasant sensations and a heightened level of arousal when smoking (6). Pupillary constriction and peripheral vasodilation are oppositely affected by smoking in the smoker versus the nonsmoker. The deprived smoker experiences unpleasant withdrawal symptoms (5).

The acute effects of cigarette smoking differ from the chronic effects. For example, nicotine initially acts as a CNS stimulant, but with chronic use behaves as a depressant (5).

The visual effects of the various components in cigarette smoke, i.e., carbon monoxide (CO), nicotine, cyanide gas, or other byproducts, are controversial because they are difficult to isolate and may be additive or competitive. For example, some

studies have postulated that the depressant effect of CO may be neutralized by the stimulant effect of nicotine (6,7), thereby offsetting any effect on night vision.

Nonetheless, our opinion is that there are compelling operational and health reasons to restrict smoking before and during night flying missions. From our literature review, several robust studies reported significantly worse performance for smokers than nonsmokers on dark adaptation tasks (8,9,10). Many of the studies that reported no change in other tests of night vision had trends that favored nonsmokers over smokers; these trends were not statistically significant because of limited sample sizes (3,11). One well-done study found that temporary abstinence from smoking could sharply improve the night vision of smokers (11). Several studies found that smokers were more likely to have automobile accidents than nonsmokers (12,13,14). Another study reported that, among people who had automobile accidents, smokers were more than two times as likely to have their accidents at night (15).

A study by USAFSAM/NGOP involving 300 USAF inductees found a statistically significant decrement in mesopic contrast sensitivity for smokers compared to nonsmokers (16). This loss of retinal sensitivity is noteworthy because the subjects were young males, 18-22 years of age, and the smokers had not smoked in 48±12 hours. Excellent mesopic visual function is important for night missions and when using NVG.

Although somewhat controversial as to exact threshold altitude, it is unequivocal that hypoxia will degrade night vision (17-21). Carbon monoxide from cigarette smoke creates an hypoxic effect that is additive to any altitudinal hypoxia. Thus, a smoker is effectively at a higher altitude than the relative aircraft cabin pressure because of the additional hypoxia induced by the CO in tobacco smoke. This may or may not be an operational problem, depending upon the cabin altitude and other physiologic conditions. Unfortunately, other nonsmoking aircrew members are also exposed to these CO-induced hypoxic effects. These effects take some time to resolve, as the half-life of CO in normal ambient air is 320 min (22). The half-life is reduced to 80 min with 100% oxygen and a tight-fitting mask. The effects may be prolonged at higher altitudes.

Smoking aboard operational aircraft can create problems in optical clarity. Cigarette smoke deposits a dirty film on windscreens, canopies, HUD combiner lenses, visors, and spectacles that can reduce acuity and contrast sensitivity, both during the day and at night. The unique properties of nicotine to penetrate into narrow spaces and to chemically adhere to most surfaces led airframe manufacturers to use nicotine staining to mark the locations of structural failures and loss of pressurized cabin integrity.

Smoking is obviously dangerous on the battlefield at night. Even very faint lights are easily detected by an enemy equipped with night-vision-enhancing devices, e.g., NVG, FLIR. The glow from a cigarette, when viewed from a distance of one mile with ANVIS NVG, appears as bright as a beacon.

Smoke may also affect inflight eye comfort in smokers and nonsmokers, especially in contact lens wearers. Combined with relative ambient hypoxia and the dryness of the air, irritating cigarette smoke was suspected to be a contributing factor in reduced

contact lens comfort and loss of corneal integrity in a field study aboard USAF transport aircraft (23). A smoke-contaminated cabin atmosphere could become a problem in the future as the number of aircrew wearing contact lenses dramatically increases.

Finally, the chronic effects of active or passive cigarette smoking must be considered. Smoking is believed to accelerate the overall aging process in humans and, among other things, to affect the ocular accommodation system (9,24). These effects may alter the dark focus of accommodation and lower the age of onset of presbyopia and bifocal wear. Long-term smoking has also been suggested as a contributing factor in the development of cataracts (25). Must nonsmokers, against their will, be subjected to these systemic and ocular risks?

It would be exceedingly difficult to obtain a definitive resolution to this controversial issue. A massive commitment of resources, professional personnel, and subjects would be required. However, smaller medical and visual studies of isolated factors could be conducted, (e.g., Nicorette gum and mesopic vision), although not without difficulty.

BIBLIOGRAPHY

1. Dyer FN. Smoking and soldier performance: A literature review. USAARL Report No. 86-13, Ft Rucker, Alabama, June 1986.
2. Fine BJ, Kobrick JL. Cigarette smoking, field dependence and contrast sensitivity. *Aviat Space Environ Med* 58:777-782, 1987.
3. Wiley RW. Dark adaptation and recovery from light adaptation: Smokers versus nonsmokers. *Mil Med* 154:427-430, August 1989.
4. Night Vision: Current research and future directions. Symposium Proceedings. Committee on Vision, National Research Council, National Academy Press, Washington D.C., 1987.
5. *Physicians Desk Reference*. 42nd edition, pp. 1070-1073. New Jersey: Medical Economics Company, 1988.
6. Wesner K, Warburton DM, Matz B. Effects of nicotine on stimulus sensitivity and response bias in a visual vigilance task. *Neuro-psychobiology* 9:41-44, 1983.
7. Robinson F, Petrig BL, Riva CE. The acute effects of cigarette smoking on macular capillary blood flow in humans. *Invest Ophthalmol and Vis Sci* 26(5):609-613, 1985.
8. Calissendorff B. Effects of repeated smoking on dark adaptation. *Acta Ophthalmologica* 55:261-268, 1977.

9. Luria SM, McKay CL. Visual processes of smokers and nonsmokers at different ages. *Arch Environ Health* 34(6):449-453, 1979.
10. Young HR, Erickson TA. Effects of combat vehicle interior light colors on dark adaptation and detection by night vision devices. U.S. Army Tank-Automotive R&D Command Laboratory Technical Report No. 12485, pp. 1-24, Warren, Michigan, 1980.
11. Luria SM, McKay CL. Effects of low levels of carbon monoxide on vision of smokers and nonsmokers. *Arch Environ Health*, pp. 38-44, Jan/Feb 1979.
12. McGuire FL. Smoking, driver education and other correlates of accidents among young males. *J Safety Research* 4:5-11, 1972.
13. Kraus AS, Steur R, Ghent WR, Thomason MG. Pre-driving identification of young drivers with a high risk of accidents. *J Safety Research* 2:55-56, 1970.
14. Ashton H, Savage RD, Telford R, Thompson JW, Watson DW. The effects of cigarette smoking in the response to stress in a driving simulator. *Brit J Pharmacol* 45:546-556, 1972.
15. Grout P, Cliff KS, Harmon ML, Maclin D. Cigarette smoking, road traffic accidents and seat belt usage. *Public Health* 97:95-101, London, 1983.
16. Miller RE II, Turner CA, Placette JJ. The long-term effects of smoking on mesopic vision in a select population. USAF School of Aerospace Medicine, unpublished data, 1988.
17. McFarland RA, Roughton FJW, Halperin MH, Niven JJ. The effects of carbon monoxide and altitude on visual thresholds. *Aviat Med*, pp. 381-394, December 1944.
18. Pretorius HA. Effect of oxygen on night vision. *Aerospace Med* 41(5):560-562, 1970.
19. Ernest J, Krill AE. The effect of hypoxia on visual function: Psycho-physical studies. *Investigative Ophthalmol Vis Sci* 10(5):323-328, 1971.
20. Kobrick J. Effects of hypoxia on the luminance threshold for target detection. *Aviat Space Environ Med* 54(2):112-115, 1983.
21. Kobrick JL, Zwick H, Witt CE, Devine JA. Effects of extended hypoxia on night vision. *Aviat Space Environ Med* 55(3):191-195, 1984.
22. Peterson JE, Stewart RD. Absorption and elimination of carbon monoxide by inactive young men. *Arch Environ Health* 21:165-171, August 1970.

23. Dennis RJ, Flynn WJ, Oakley CJ, Tredici TJ. A Field Study on soft contact lens wear in USAF military transport aircraft. USAFSAM-TR-88-4, Brooks AFB, Texas, April 1988.
24. Roberts JO, Adams AJ. The short-term effects of smoking on ocular accommodation and pupil size. J Amer Optom Assoc 40:528-530, 1969.
25. West S, Munoz B, Emmett EA, Taylor HR. Cigarette smoking and risk of nuclear cataracts. Arch Ophthalmol 107:1166-1169, 1989.

APPENDIX C

DESCRIPTION OF AN/PVS-5 NVG

1. The AN/PVS-5 is a self-contained viewing device, worn in front of the eyes, that uses II-Gen intensifier tubes.

2. The device is a binocular unit consisting of two identical monocular assemblies mounted on an adjustable frame.

a. Each monocular unit consists of an objective lens, an image-intensifier (I^2) assembly, and an ocular (dioptric) lens.

b. The two I^2 tubes form a binocular device which is attached to the aviator's helmet.

c. An intensified image is presented on a phosphor screen.

d. Each tube must be individually focused with both the objective and ocular (dioptric) lenses, and adjustments can be made for different interpupillary distances, elevation, tilt, and eye relief (fore and aft).

e. The optimum field of view is a circular 40 deg.

3. The AN/PVS-5 weighs approximately 28 oz and is 6.5 inches square.

4. Power is provided by 1 round 2.7 volt DC mercury battery. This battery will last approximately 12 hours at 70° F. The recently introduced GM-6 helmet mount incorporates the ANVIS dual battery pack.

5. The AN/PVS-5 will operate over an illumination range from cloudy starlight to full moonlight; however, performance is significantly degraded below 50% moonlight levels. For training purposes, however, 20% ambient light and a moon angle of 30 deg above the horizon are bare minimums.

5. Operating Instructions

a. Remove the lens caps and turn room lights off. Set the rotary switch to ON and observe that a green glow is visible in each eyepiece (after a slight delay).

b. Loosen the lever clamp and adjust the monoculars for the proper interpupillary distance. The interpupillary distance can be obtained from the eye clinic and, using a millimeter ruler, the NVG tubes should be set apart that distance. Then retighten both lever clamps.

c. Loosen the helmet-mount clamp knobs (if the GM-6 helmet mount is used) and adjust the binocular assembly until the eyepieces are located a comfortable distance from the eyes. Retighten both clamp knobs.

d. Turn the objective focus knob fully counterclockwise on each tube. This sets the lens for farthest distance viewing.

e. Close the left eye and adjust the right ocular (dioptric) adjustment ring to obtain the clearest and most comfortable distance view. This adjustment is properly accomplished by turning the dioptric adjustment ring all the way counterclockwise and then turning it slowly back clockwise until the first clear focus is reached to ensure minimal accommodative effort and prevent eyestrain. Repeat adjusting the objective lens for best focus and then refine the dioptric focus. Close the right eye and adjust the left objective and dioptric adjustment lenses similarly.

f. Check that the IR illuminator, if applicable, has not been turned on by passing your hand directly in front of the goggles. If contrast appears extra bright, turn the rotary switch back to the ON position. The purpose of the IR illuminator is for viewing within 2 meters.

g. Operation for sharp focus: Turn the focus on each objective lens clockwise until a sharp focus is obtained at the working distance desired. At this setting, distant objects will not be in sharp focus.

h. Modified Faceplate: The modified faceplate version (Fig. 4-8) has the on/off switch and battery container relocated on top of the mask. The mask is cut away on the sides and bottom; this design provides for a "look-under" and limited "look-around" capability. The modified NVG can still be mounted on the helmet in the same manner as the uncut version. However, a new helmet mounting style, which includes a counterbalance weight and dual battery pack, has been designed. Helmet modifications to use an ANVIS mounting style (Cobb GM-6 mount) have been authorized. Thus, the AN/PVS-5 can be attached to the flying helmet, which allows normal communications between crewmembers. All crewmembers should use their NVG with flight helmets for safety reasons.

APPENDIX D

DESCRIPTION OF ANVIS

1. The ANVIS was designed specifically for rotary-wing aircraft, to overcome the shortcomings with the AN/PVS-5 NVG.

2. The ANVIS is a lightweight, high-performance, image-intensification system for optimizing helicopter night flying at terrain-masking altitudes.

3. The III-Gen light amplification tubes provide an operational capability during periods of low ambient light down to overcast starlight conditions.

4. The ANVIS retains the 40-deg field of view.

5. The binocular assembly mounts directly on the flight helmet and allows peripheral vision around and underneath for viewing the instrument panel and obtaining peripheral cues.

6. The ANVIS can be worn with aircrew eyeglasses and is compatible with most oxygen masks.

7. Power can be supplied by a standard AN/PVS-5 mercury battery, a lithium battery, two double A batteries with an adapter, or converted from aircraft power.

8. The ANVIS weighs approximately 12 oz. A dual battery pack may be attached to the rear of the helmet. A red indicator light glows when battery power is low. The ANVIS has a flip-up design and can be worn continually in its hot-shoe mount. The NVG power supply will automatically shut off when placed in the up position.

9. Operating Instructions

a. The ANVIS operates basically the same as the AN/PVS-5. Focus and interpupillary distance adjustments are located similarly on the mount.

b. The ANVIS does not have an IR illuminator.

c. Because of the "look-around" capability, pilots do not normally need to focus the ANVIS for inside-the-cockpit viewing. However, other aircrew members who work inside the aircraft cabin may frequently need to focus for inside tasks.

10. Capabilities - Aircrew members are capable of performing tasks normally performed during daylight (i.e., takeoff, navigation, low-level terrain flight, and landing). However, resolution/visual acuity, depth perception, and field of view are reduced from normal photopic levels.

APPENDIX E

ANVIS VERSUS AN/PVS-5

1. Both NVG systems are image-intensification devices that amplify low-level ambient light reflected from objects.

a. The II-Gen NVG have a typical system gain of 400 and an average display luminance between 0.3 and 0.9 ftL.

b. The III-Gen tubes in the ANVIS operate similarly to the II-Gen, but they have greater sensitivity and resolution, operate over a slightly different spectral range, have a system gain of 2,000–5,000, and have an average display luminance of 0.7 to 2.2 ftL.

2. From the user's point of view, the major difference between NVG and ANVIS is that the ANVIS, with III-Gen tubes, is usable during periods of lower light levels, where starlight is the only source of illumination. The ANVIS has a much greater sensitivity to low light than the AN/PVS-5 which is particularly evident when you compare their sensitivity in the night sky.

3. In addition to the previously discussed mechanical comparisons between the two NVG systems, there exists a significant difference in their sensitivity to light.

a. The naked eye is sensitive to light in the range from 380 nm to 760 nm. Its peak sensitivity lies in the blue-green spectral range at night, and in the green-yellow spectral range during daylight.

b. The AN/PVS-5 operates from the lower visible light scale of about 390 nm to the near-IR at about 900 nm. The peak sensitivity is in the mid-visible spectral range.

c. The ANVIS operates from red visible light at 625 nm to the near-IR at about 900 nm. For cockpit lighting compatibility, the interior surfaces of the objective lenses of the ANVIS are coated with a dielectric film (minus-blue filter) that rejects wavelengths below 625 nm. The peak sensitivity is in the red spectral range.