

# Nikola TESLA's Wireless Systems

André Waser\*

Issued (German): 29.07.2000  
Last changes (English): 05.08.2000

After his inventions about the polyphase powering systems Nikola TESLA has focused himself more to experiments with high voltages, high currents and high frequencies. One of his goals was to transmit electrical energy without a power network directly from a central plant to the different consumers. In New York TESLA has done his first trials for this new technology. Then at the change of the century 1899-1900 TESLA moved to the high lands of Colorado Springs. There he has executed so many experiments, which has not been repeated in all its details and specialties until these days. Now, exactly one hundred years after a review about this impressive and important experiments may be of a particularly interest.

## Introduction

It is surprising how little information can be found in literary about the work of the famous Serbian experimenter Nikola TESLA. In the contrary his antagonist Thomas EDISON, which mainly promoted the direct current systems, is mentioned where ever one looks. But it was Nikola TESLA who invented the today used polyphase power system in all its part of generation, transmission and consumption. It was Tesla, not EDISON, who has made the world-wide use of electricity even become possible.

And today almost all publications about TESLA's work are looking at his high frequency and high voltage transformers, known under the summary term „Tesla-Coil“. From time to time some papers has been published about this specific topic; for example for a repetition of some experiments<sup>[3],[7],[16]</sup>, about applications of this transformers<sup>[1],[9],[17]</sup>, about the measurement on such devices<sup>[49]</sup> or about some theoretical considerations<sup>[2],[4]</sup>.

Very special arrangements of the TESLA coils are the power transmitting and receiving devices of Tesla. Konstantin MEYL has recently published many papers about this topic. MEYL<sup>[10]-a,[11]-a</sup> has used the same speculative explanation hypothesis as the author<sup>[44]</sup> has used at an earlier time and which are – as suggested now – not necessary anymore.

It is typical for an experimental explorer that he discovers unexpected results and finds new facts only because he makes some leading experiments on the basis of speculative models. And because of this TESLA was far ahead of the theoretical knowledge of that time with his experimental practices. Therefore a communication with the established science was not always easy for him, what could be a reason (beneath of commercial interests) that Tesla has more or less stopped his publications in scientific journals after the year 1899 and since then only published in popular daily or weekly newsletters.

---

\* André Waser, Birchli 35, CH-8840 Einsiedeln, Switzerland

## Wireless transmission of electrical energy

In the years 1884-1889 TESLA got different patents for his alternating polyphase technology, which has been a substantial breakthrough at that time against the direct current technology. But leading economists and companies in Europe didn't understand TESLA's visions and he was forced to emigrant in the USA. Together with George WESTINGHOUSE TESLA made it possible to build the first alternating power station of a large scale at the Niagara Falls in 1893. But the first patent<sup>[19]</sup>, which reveals the landmark thoughts TESLA's, was filed in the year 1891 and is a fully description of a high frequency lighting system. The specific feature of this system is the use of only one supplying single wire to the particularly build and patented single terminal carbon lamps without a return wire. (The patent has been granted in the record time of only two months.)

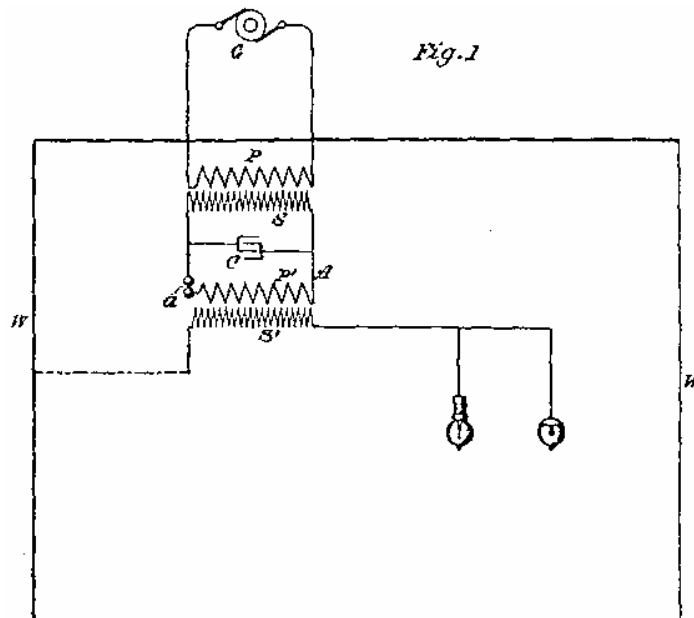

Figure 1: US-Patent 454,622 „System of Electric Lighting“ issued on June 23<sup>rd</sup>, 1891<sup>[19]</sup>

With the first transformer P-S the alternating voltage of generator G (about 5 kHz) is transformed to high voltage. The resonance circuit S-C is then vastly discharged along the spark gap. As a result there are high current peaks in the primary winding P' of the second transformer. With this second transformation the high frequency part of this current peaks is again transformed upwards and feeds the load circuit. One end of the second secondary S' is connected to a long wire or wire grid W positioned along the room walls. The other end is connected to TESLA's invented single terminal lamps. In opposite to the lamps used today this lamps have only one connector. And this connection leads to an electrode – mostly made from carbon – inside the fully or partly evacuated glass bulb. On different occasions TESLA<sup>[18],[20],[22]</sup> has demonstrated, that this high frequency currents and voltages do not cause immediate injury to the experimenter (himself) or the audience.

This patent shows all characteristics of the high frequency circuits with high voltage and high currents as used by TESLA. In the following steps TESLA optimized the technology of generation and utilization of high frequency and high voltage apparatus, which he mostly applied to lighting systems with different kinds of bulbs. In the year 1897 he applied for three patents about the transmission of electrical energy. The first patent<sup>[23]</sup> he registered on March 20<sup>th</sup> about a high frequency transformer with high power capabilities. Besides a common ground connection this transmission method needs only one transmission wire.

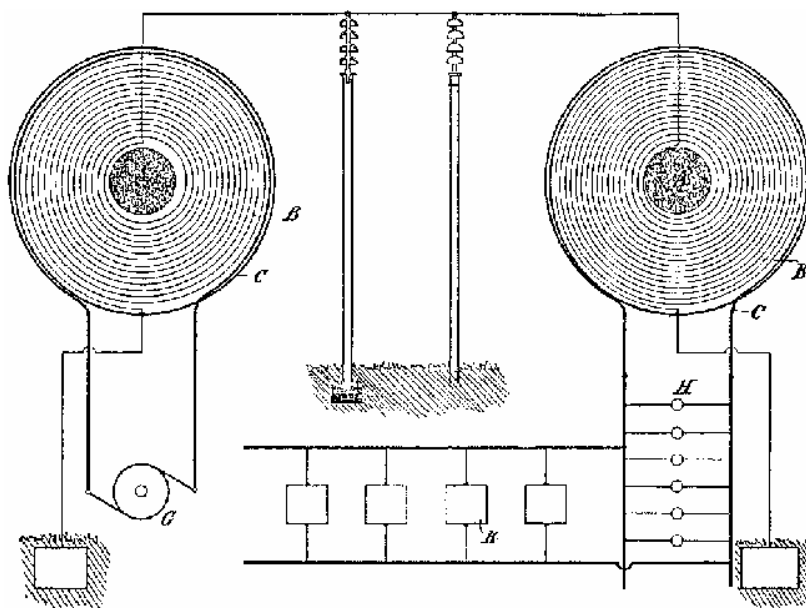

Figure 2: US-Patent 593,138 „Electrical Transformer“ issued on November 2<sup>nd</sup>, 1897

The generator G supplies the primary of the flat coil C. This simplified diagram does not come very close to the real experimental setup<sup>[27]</sup>. Then as previously shown with the patent about the lighting system an intermediate step-up transformation with a spark gap and a high voltage transformer is necessary to achieve a resonant frequency of some million cycles per second. With some advantages it is also possible to use this step-up transformation after the flat secondary coil B. This flat coil TESLA<sup>[21]</sup> has extra patented because of its excellent performance with high voltage and high frequency signals. On one end the secondary B is connected to ground and on the other end to the transmission wire which is connected to a receiving device with a flat coil B' of a symmetrical form. With a step-down transformation with the coil C' the electrical energy is finally transmitted from the generator G to the load L with only one conducting wire.

Some months later TESLA<sup>[27]</sup> has shown that the transmission wire can be dropped completely and can be replaced by a glass tube filled with air of low pressure.

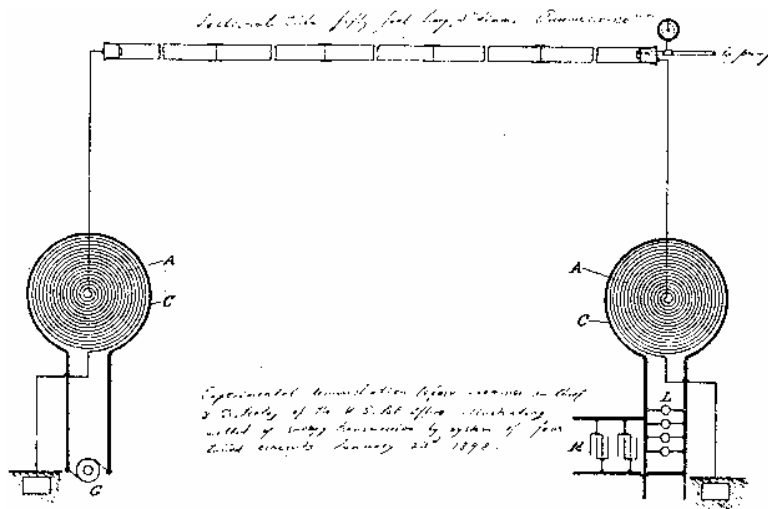

Figure 3: Slide of Nikola TESLA<sup>[27]</sup> about the energy transmission through a partly evacuated glass tube; dated of January 23<sup>rd</sup> 1898.

In figure 3 the arrangement of figure 2 can be found again. With this discovery of the good electrical conductivity of air of low pressure the path was free for further developments.

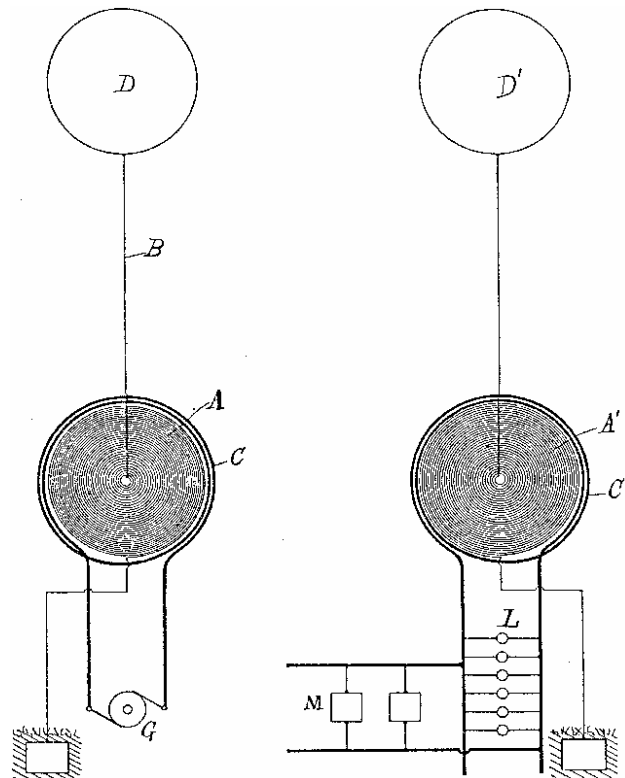

Figure 4: US-Patent 645,576 „System of Transmission of Electrical Energy“ filed on September 2<sup>nd</sup> 1897, issued on March 20<sup>th</sup>, 1900

Then on September 1897 TESLA<sup>[24],[25]</sup> has filed two other patents for the transmission of electrical energy (figure 4). But the granting of this patent has been made dependent of the experimental success as a corresponding part in the patent shows (Pat. 645'576, p. 3, col. 2).

In this patents TESLA writes of a grounded high frequency emitter with a highly elevated ball electrode which was in resonant connection with a symmetrical, grounded resonant circuit (receiver) to enable the energy transmission through the upper atmosphere, which in great heights becomes more and more conductive for electrical currents.

The *Electrical Review*<sup>[24]</sup> of London published on May 1899 a summary of articles about the work of Nikola TESLA previously published by their New York colleges. Here TESLA stated that the air will have a sufficient conductivity for his experiments, if the ball electrodes are placed in a height of four miles (~6.5 km). This could probably be done by balloons, TESLA suggested.

Trained with many experiments TESLA left New York on May 11<sup>th</sup> 1899 to the highlands of Colorado Springs (2000 m about sea level) where he experimented<sup>[27]</sup> with several systems for the transmission for electrical energy until the turn of the century on January 11<sup>th</sup> 1900. One of the goals was to prove by experiment the feasibility of his patent applications of 1897. As a result of his experiments he got his second patent<sup>[24]</sup> on March 20<sup>th</sup> 1900 and his third patent<sup>[25]</sup> on May 15<sup>th</sup> 1900. And only one day after he got this third patent he filed an other, very important patent<sup>[32]</sup>. In this patent he describes for the first time in detail the energy transmission through the earth and gives more information about signal detection (figure 5).

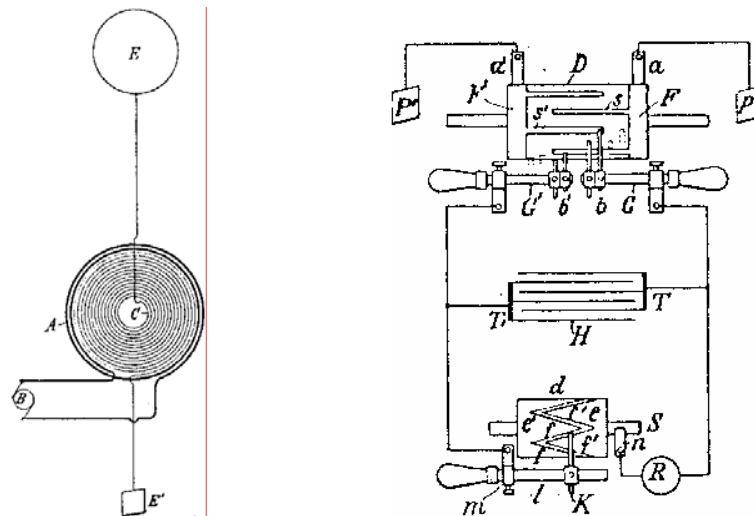

Figure 5: US-Patent 787,412 - „Art of Transmitting Electrical Energy Through the Natural Mediums“ filed on May 16<sup>th</sup> 1900, issued on April 18<sup>th</sup> 1905.

Obviously he was only able to file this patent after the other two patents from 1897 has been granted. And this is because the older patents and this new one does contradict each other in the description of the method of the energy transmission in essential points! The results of the Colorado Springs experiments has motivated TESLA to replace his previous patents – based on his New York experiments – with a newer and accurate one.

Almost during his work in Colorado Springs TESLA<sup>[28] to [31]</sup> filed continuously some patents which report his experimental progress in detail but which are mainly focused on the receiving devices only and not on the full system of transmitter and receiver.

The topic of signal transmission through the earth has engaged Tesla further and two months later he again filed a patent<sup>[39]</sup> which shows some different methods for signaling with and without the use of transmitting wires.

All his efforts culminated in a project for the transmission of electrical power of 10MW in Wardencliffe<sup>[1]</sup>, USA, which has never been completed probably because of low fundings. The basic arrangement for the large scale power transmission was published in his last patent<sup>[40]</sup> file of this kind.

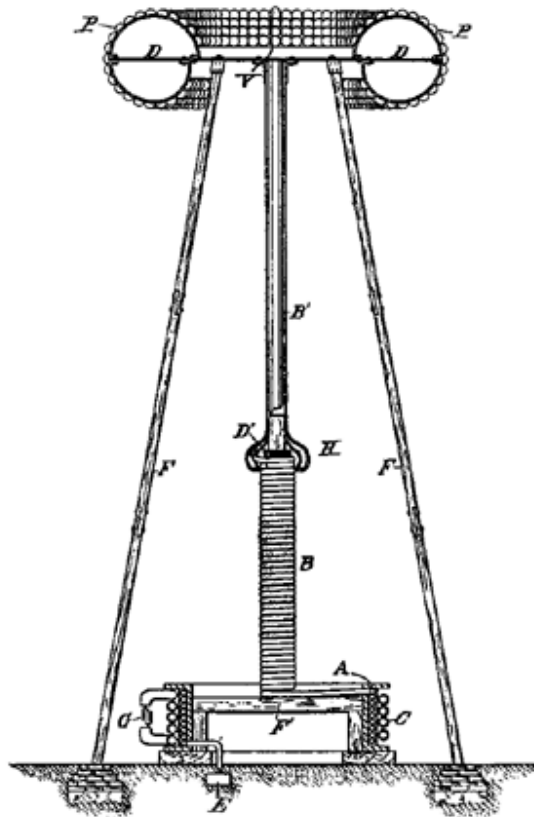

Figure 6: US-Patent 1,119,732 - „Apparatus for Transmitting Electrical Energy“ filed on January 18<sup>th</sup> 1902, issued on December 1<sup>st</sup> 1914.

This enormous work TESLA's, which has not – or only perfunctory – been published in the scientific publications of that time, is worth to be reconsidered at least partly on the basis of today's knowledge and theories.

On the first glance to the series of figure 2 to 4 one supposes that the energy transmission finally occurs through the air by the means of an increasing electric conductivity of the upper atmosphere. Actually TESLA<sup>[24],[25]</sup> has written in his first patents that this is the case. But with

a closer look at his drawings there can be recognized that all his circuits has – beneath the high voltage transformers – an other common thing: the ground connection. In later publications TESLA<sup>[32],[36],[32]</sup> has mentioned explicitly that the really conductor of the power transmission is the Earth itself. The Earth acts like a giant reservoir for electrical charges which can be set into oscillation by his powerful equipment. Is now a very sensitive resonant circuit (receiver) placed on an other place on Earth, which is tuned to the transmitter's frequency, then the receiver couples to this oscillations and gains its signals due to resonance.

This electrical excitement of the Earth TESLA<sup>[27]-S.61, [36]</sup> has discovered in a stormy night from July 03<sup>rd</sup> to 04<sup>th</sup> 1899 in Colorado Springs. To his great surprise he detected standing waves on the Earth surface after heavy lightning. With his sensible equipment he was able to record that the signals first diminished when the storm passes away but then again increased and later on diminished again and so fourth. Of a special interest for Tesla was the fact that the different maximum readings almost increased the more the storm was moved away from the receiver, and this to an estimated distance of about 200 miles.

The receiver must be constructed according to figure 4 by enabling powerful oscillations between Earth and the elevated charge terminal D', if it is used for energy transmission. If only signals are to be detected, then it is sufficient to have a receiving device according to figure 5, which only detects and demodulates electrical signals on Earth's surface.

After his discovery on July 3<sup>rd</sup> 1899 TESLA obviously has done further measurements, which he has not published in great detail, but on which he has made some insinuations<sup>[32]</sup> after his time in Colorado Springs. Beneath some distortions due to lightning and other influences due to sun eruptions and aurora borealis he also discovered a week periodic signal. He was only able to speculate about the origin of this signal, which he recorded with his very sensitive devices.

Today we can assume with great certain that TESLA has detected radio signals from pulsars, from which he erroneously thought<sup>[35]</sup> they are signals from intelligence of civilizations on other planets. Since 1967 the radio signals of pulsars has not been detected again by science. The team of Antony HEWISH<sup>[6]</sup> in the Cavendish-Labor of Cambridge has re-discovered this signals, for which HEWISH received 1974 the Nobel price of physics, which really had been admitted to TESLA. It is typical for the awarding of this Nobel price, that Jocelyn BELL-BURNELL, who has worked in HEWISH's team and who first has noticed the absolutely unknown and curious peaks of a period of  $1\frac{1}{3}$  seconds on the recorded signals, also not has been nominated .

TESLA intended to transmit huge amount of electricity through the atmosphere and discovered with his experiments in Colorado Springs<sup>[27]</sup> the surprising fact of Earth's electric conductivity. By using the whole planet as a receiving device Tesla had the biggest radio telescope ever used on Earth to detect signals from outer space. He was not able to determine the exact direction of the incoming signals but the sensitiveness of his receiving equipment was so extremely high (for that time), that he was able to detect this signals from which we know today that they come from pulsars and magnetars. This is – beneath the discovery of the X-rays (later named by Roentgen) – his second missed Nobel price.

## Analysis

The force of an oscillating HERTZ dipole on a stationary charge is well known. This can also be described as a sum of forces between relatively resting, moving and accelerating charges as the author<sup>[45]</sup> has shown for the case of large distances to the HERTZ dipole. A transmission of electrical energy from one point to an other is certainly possible with a HERTZ dipole, too. But with increasing distance  $r$  from the transmitter the energy density diminishes rapidly. This law of distance can be undergone when instead of air under normal pressure a conducting medium (electrical wire) is used. An almost frictionless transmission of electrical energy between two points on Earth without wires only can be done by using some sort of a 'connecting wire', a voltage or current source and a load. This connecting wire is the Earth. The voltage or current source is the transmitter and the receiver is the load.

The elevated terminals D and D' function as a charge reservoir (electric capacitor), but they do not act as the transmitting terminal itself, whereas the energy is given off to the air. If no transmission through air is planned, it is preferred to insulate this terminals so that no charges are lost to the atmosphere. This has been sometime described by TESLA. For a simpler construction TESLA could have placed the capacitor terminals D and D' beneath the transformers A-C and A'-C' respectively. But obviously the specific arrangement of the terminals D and the supply wire B as shown in all patent drawings is very important for the correct function of the apparatus.

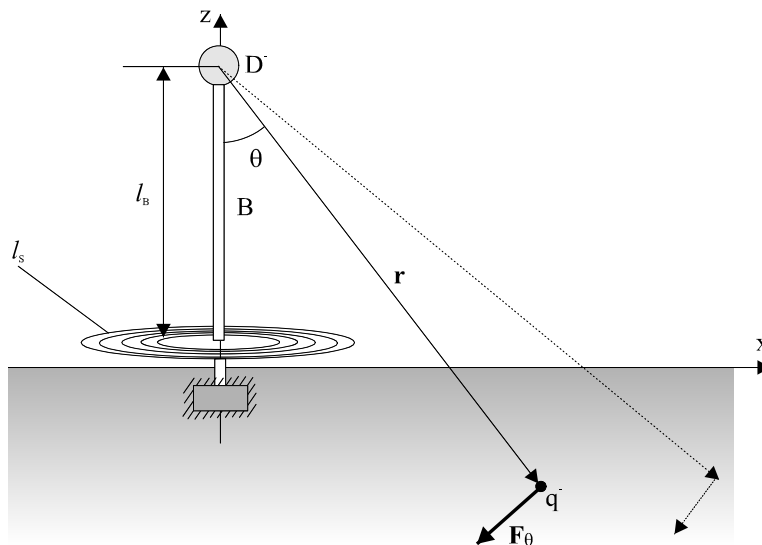

Figure 7: Accelerating dependent forces of a TESLA transmitter on negative charges in the Earth.

TESLA has operated the Earth as a ball capacitor. The transmitter "pumps" with a frequency between 20...250kHz<sup>[24],[32]</sup> electrons between the Earth and the elevated terminal back and fourth. To minimize the HERTZ radiation losses this frequency has to be as low as possible, as TESLA has mentioned explicitly. To achieve an optimal effect it is necessary to use high voltages. Tesla has tuned the whole conductor length consisting of the secondary coil A and of the conductor B to the wave length of the resonant frequency of the secondary.



With this tuning the voltage between ground and terminal rised up to more than four Million Volts. To produce such high voltages a resonant circuit with high efficiency (low damping) is requested, as TESLA mentioned many times. For that he sometimes used his flat spiral coil. The main goal is to move as many charges as possible in a short time from the terminal down to the usually bad conducting ground and back to the terminal again.

If we look at the transmitter oscillating with the resonant frequency  $\omega$  then the equation of the force between resting, moving and accelerating charges <sup>[45],[46]</sup> can be applied. At the considered time the terminal D should be fully charged with electrons.

The conductor part  $l_B$  is much shorter than the conductor  $l_S$  used in the coil S as arranged in the TESLA experiments. So we can assume with high accuracy that the current is not a function of the direction z. Then, for example, on a distance  $r \gg l_B$  the acceleration dependent force<sup>[45]</sup> acts on charges in the vicinity of the transmitter proportional to  $1/r$ :

$$\frac{\mathbf{F}}{q} = \frac{I l_B}{4\pi\epsilon_0} \frac{i\omega}{c^2 r} \sin\theta \mathbf{r}_\theta^0 \quad (0.1)$$

That means, the electrons previously sitting in D are not only locally pressed into ground but in addition there acts a force  $\mathbf{F}_\theta$  on every ,free‘ charge in the Earth (and atmosphere), which is inverse proportional to the distance to the transmitter. This force pushes (or pulls) the negative charges in the Earth down to deeper layers (or up again to the transmitter). Additionally there acts also a force proportional  $1/r^2$  to on every charge in the ground around the transmitter. Only the simple “injection” of electrons into ground has a much smaller effect than the forces of the moving and accelerating charges in the wire element B.

With this explanation it is clear why Tesla used such high voltages or why he always intended to use as much charges as possible in his circuits. The effects of the moving and accelerating charges in the wire B depends directly on the number of involved electrons and of the frequency of the apparatus. The acceleration can not be made higher in ordinary conductors but the number of electrons can be increased with higher voltages. And the increasing of the voltage was always TESLA’s intention.

The energy of the transmitter is used for the acceleration of the free charges in Earth, which in turn again accelerate more distant charges in the ground. The result is a longitudinal wave of oscillating electrons across the Earth’s diameter. And exactly this is what TESLA<sup>[32]</sup> always has claimed to do. If the Earth would be a body of unlimited size, the impressed wave would be dissipated as well as the involved energy. But because of the finite size of the Earth the longitudinal wave soon approaches the borderline to the atmosphere where it will be reflected similar to sound waves. The really astonishing fact is, that the longitudinal wave through the Earth is close to the speed of light in vacuum as can be calculated form TESLA’s patent information.

If the Earth is electrically struck – for example by lightning – there will always be at least two basically different resonances. The main resonance between Earth and atmosphere is known as SCHUMANN resonance<sup>[14],[15]</sup> and has a frequency of about 7.9 Hz, whereas the TESLA resonance is 11.8 Hz. Both different resonances are again presented in figure 8.

The Earth behaves like a perfect electrical conductor: *„...the planet behaves like a perfectly smooth or polished conductor of inappreciable resistance with capacity and self-induction uniformly distributed along the axis of symmetry of wave propagation and transmitting slow electrical oscillations without sensible distortion and attenuation.“* This wave is concentrated and reflected exactly at the opposite pole of the planet as Charles YOST<sup>[49]</sup> and HARTHUN et. al.<sup>[5]</sup> has shown. TESLA describes in one<sup>[32]</sup> his patents the velocity of the

surface wave along the Earth's circumference from pole to pole in words as to be  $v_0 = 471'0240$  km/s. This means, the wave velocity through the Earth along the diameter  $2r_E$  is close to the speed of light in vacuum, then it is:

$$\frac{v_0}{c} = \frac{l_0}{2r_E} = \frac{\pi}{2} \quad \rightarrow \quad v_0 = c \frac{\pi}{2} \quad (0.2)$$

So the speed of the longitudinal wave through the Earth is close to  $c$ . The main longitudinal resonance is 11.79 Hz. With this longitudinal wave of free electrons in the ground the whole Earth is set in resonance. The Earth diameter must be an odd multiple of a quarter wavelength of the transmitter. Then, to produce a forward and backward wave front, the signal must be applied at least for 0.085 seconds to achieve a standing wave. And exactly all this numbers are given in TESLA's patent<sup>[32]</sup>.

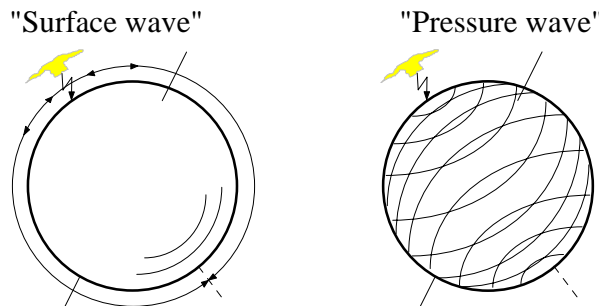

Figure 8: Difference of SCHUMANN (left) and TESLA (right) resonance

Once there are built such standing waves it is possible to produce on different places on the globe wave knots, where the excitation is a maximum and places where no oscillation can be measured. Preferably on the places of maximum oscillations a receiver is placed. This receiver is built symmetrically to the transmitter. Because of its low OHM'ic losses the receiver gains its amplitude due to resonance. Then the receiver becomes a transmitter, too. The receiver also builds a standing wave in strong synchrony with the transmitter and as a result the energy transmission can be started, if a load is placed on the receiver as shown in figure 4. Principally this energy transmission is possible in both directions.

First the transmitter must supply the energy to build up the standing wave in Earth and the to build up the receiver's oscillations. This does not require a high energy throughput. Then, as Tesla states, if this standing waves are established in perfect synchrony an energy transmission can be done without heavy losses. The energy consumed by the receiver (and the losses) out of the standing waves must be supplied by the transmitter to hold the oscillating system through the Earth alive. According to TESLA<sup>[2]</sup> the requested energy transmission can be made with an efficiency of 99.5%.

The assumption<sup>[10]b</sup>, that TESLA has received more energy than transmitted – and therefore gave his system the name „Magnifying Transmitter“ – can neither be definitively confirmed nor rejected with the presented analysis. There exists a text passage<sup>[4]</sup> that may support this assumption, but in most other original publications TESLA<sup>[2],[3],[3]</sup> always claims of an efficiency of about 99%.

If only the receiving of signals is requested, the receiver can be built much cheaper, because it has not to induce also a standing wave into Earth. Also the transmitter does not necessarily have to produce a standing wave in Earth so that every desired frequency can be

used. According to figure 5 (right side) the receiver can detect the potential difference between two distant points on the Earth surface. It is possible to receive signals around the globe as well as under water with this method.

TESLA has used high voltages and high currents, as he often said. The noise of his experiments in Colorado Springs was detectable many miles. Despite the fact, that he doesn't involve such large amounts of energy as assumed to be released in thunderstorms, the analogy to lightning is allowed. So the Earth's longitudinal resonance should be detectable if lightning strikes the Earth surface. Actually it can be seen by eyes that the lightning brightness appears to flicker. It is known<sup>[8]</sup>, that with ground lightning the flash strikes two to four times the same location within a time duration between each stroke between 40...80 milliseconds. This corresponds to the propagation time of a forward and backward wave through Earth close to the speed of light in vacuum.

Up to this point the transmitter and receiving devices are described in its basic functionality. It is desirable that this particular TESLA devices would be reconstructed in fully detail as done hundred years ago in Colorado Springs to get an even better understanding what has happened.

TESLA has made much more progress after his experiments with the transmission of electrical energy as mentioned above. Over 30 years he has made much more discoveries, which he has published only partly or even nothing. But in his later years he always mentioned a new energy source he already has found in the years, where he worked with the wireless systems. About this part of TESLA's work an other paper<sup>[48]</sup> will be published.

## References

- [1] ABRAMYAN E. A., "Transformer Type Accelerators for Intense Electron Beams", *IEEE Transactions on Nuclear Science* **NS-18** (1971) 447-455
- [2] BARRETT Terence W., "TESLA's Nonlinear Oscillator-Shuttle-Circuit (OSC) Theory", *Annales de la Fondation Louis de Broglie* **16** No.1 (1991) 23-41
- [3] BRUNS Donald G., "A solid-state low-voltage Tesla coil demonstrator", *American Journal of Physics* **60** No.9 (September 1992) 797-803
- [4] HEISE Werner, "Tesla Transformatoren", *Elektrotechnische Zeitschrift A* **85** /1 (10 Jan. 1964) 1-8
- [5] HARTHUN Norbert und Axel BERNHARDT, "Tesla Transmitter", *Mensch & Technik*, Verlüßmoor, Vollersode, Deutschland (1984)
- [6] HEWISH Antony, Jocelyn BELL, J.D.H. PILKINGTON, P.F. SCOTT and R.A. COLLINS, "Observation of a rapidly pulsating radio source", *Nature* **217** (24 February 1968) 709-713
- [7] KELLY James B. and Lee DUNBAR, "The Tesla Coil", *Am. Journal of Physics* **20** (1952) 32-35
- [8] KRINDER Philip E., "Physics of Lightning", *The Earth's Electrical Environment*, *CPSMA* ISBN 0-309-03680-1 (1986)
- [9] LAURITSEN Charles C. and Richard CRANE, "A Combined Tesla Coil and Vacuum Tube", *Review of Scientific Instruments* **4** (September 1933) 497-500
- [10] MEYL Konstantin, "Elektromagnetische Umweltverträglichkeit", *Indel Verlag, Villingen-Schwenningen* Teil **1** ISBN 3-9802542-8-3 (Dezember 1996) a: 207, b: 205, c: 157
- [11] MEYL Konstantin, "Elektromagnetische Umweltverträglichkeit", *Indel Verlag, Villingen-Schwenningen* Teil **2** ISBN 3-9802542-9-1 (1999) a: 133
- [12] RATZLAFF John, "Tesla Said", *Tesla Book Company, Chula Vista*, ISBN 0-914119-00-1
- [13] RATZLAFF John T., "Reference Articles for Solutions to Tesla's Secrets", *Tesla Book Company, Chula Vista, CA-91912*, ISBN 0-9603536-3-1, Part II (1981)
- [14] SCHUMANN W. O., "Über die strahlungslosen Eigenschwingungen einer leitenden Kugel, die von einer Luftschicht und einer Ionosphärenhülle umgeben ist", *Zeitschrift für Naturforschung* **7a** (1952) 149-154

- [15] SCHUMANN W. O., „Über die Dämpfung der elektromagnetischen Eigenschwingungen des Systems Erde – Luft – Ionosphäre“, *Zeitschrift für Naturforschung* **7a** (1952) 250-252
- [16] SKELDON Kenneth D., Alstair I. GRANT, Gillan MACLELLAN and Christine MCARTHUR, “Development of a portable Tesla coil apparatus”, *European Journal of Physics* **21** (2000) 125-143
- [17] SLOAN David H., „A Radiofrequency High-Voltage Generator“, *Physical Review* **47** (01 January 1935) 62-71
- [18] TESLA Nikola, „Experiments with Alternate Currents of very high Frequency and their Application for methods of artificial lighting“, *Lecture before the American Institute of Electrical Engineers, Columbia College* (20 May 1891), Deutsche Fassung in: „TESLA’s Verschollene Erfindungen“, VAP Verlag ISBN 3-922-367-93-3 (1994)
- [19] TESLA Nikola, “System of Electric Lighting”, *US Patent 454'622* (Application filed: 25. April 1891; Patented: 23 June 1891)
- [20] TESLA Nikola, “Experiments with Alternate Currents of High Potential and High Frequency”, *Lecture before the Institution of Electrical Engineers, London* (03, 04 February 1892), Reprint in: *Lindsay Publications* ISBN 0-917914-39-2 (1986)
- [21] TESLA Nikola, “Coil for Electro Magnets”, *US Patent 512'340* (09 January 1894)
- [22] TESLA Nikola, “The Streams of LENARD and ROENTGEN and Novel Apparatus for Their Production”, *Lecture before the New York Academy of Sciences* (06 April 1897), Reprint in: *Twenty First Century Books* ISBN 0-9636012-7-X (1994)
- [23] TESLA Nikola, “Electrical Transformer”, *US Patent 593'138* (Application filed: 20 March 1897; Patented: 02 November 1897)
- [24] TESLA Nikola, “System of Transmission of Electrical Energy”, *US Patent 645'576* (Application filed on 02 September 1897, Patented on 20 March 1900)
- [25] TESLA Nikola, “Apparatus for Transmission of Electrical Energy”, *US Patent 649'621* (Application filed on 02 September 1897, Patented on 15 May 1900)
- [26] TESLA Nikola, “Tesla’s High Potential and High Frequency Work”, *Electrical Review (London)* **44**/1,119 (05 May 1899) 730-733
- [27] TESLA Nikola, „Colorado Spring Notes“, *Nikola TESLA Museum, Belgrad, Jugoslavien* Edited by Aleksandar MARINCIC (1899-1900); <http://www.etf.bg.ac.yu/Prez/Muzej/Tesla/index.htm>
- [28] TESLA Nikola, “Method of Intensifying and Utilizing Effects Transmitted Through Natural Media”, *US Patent 685'953* (Application filed: 24 June 1899; Patented: 05 Nov. 1901)
- [29] TESLA Nikola, “Method of Utilizing Effects Transmitted Through Natural Media”, *US Patent 685'954* (Application filed: 01 August 1899; Patented: 29 May 1901)
- [30] TESLA Nikola, “Apparatus for Utilizing Effects Transmitted from a Distance to a Receiving Device Through Natural Media”, *US Pat.685'955* (filed: 08 September 1899; Pat: 05 Nov. 1901)
- [31] TESLA Nikola, “Apparatus for Utilizing Effects Transmitted Through Natural Media”, *US Patent 685'956* (Application filed: 02 November 1899; Patented: 05 Nov. 1901)
- [32] TESLA Nikola, “Art of Transmitting Electrical Energy Through the Natural Mediums”, *US Patent 787'412* (Application filed: 16. May 1900; Renewed: 17 June 1902; Patented 18 April 1905)
- [33] TESLA Nikola, “System of Signaling”, *US Patent 725'605* (Application filed: 16 July 1900; Patented: 14 April 1903)
- [1] TESLA Nikola, “Tesla’s New Discovery – Capacity of Electrical Conductors is Variable”, *New York Sun* (30 January 1901); reprinted in [12] 57-58
- [2] TESLA Nikola, “Talking with the Planets”, *Collier’s Weekly*, (09 February 1901) 4-5; reprinted in [12] 61-65
- [36] TESLA Nikola, “Method of Signaling”, *US Patent 723'188* (Application filed: 14 June 1901; Patented: 17 March 1903)
- [37] TESLA Nikola, “The Transmission of Electrical Energy Without Wires”, *Electrical World and Engineer* (05 March 1904)
- [3] TESLA Nikola, “The Transmission of Electrical Energy Without Wires As a Means for Furthering Peace”, *Electrical World and Engineer* (07 January 1905) 21-24; Reprinted in [12] 78

- [39] TESLA Nikola, "Method of Signaling", *US-Patent 723'188* (Application filed: 16 July 1900, divided on 14 June 1901, Patented: 17 March 1903)
- [40] TESLA Nikola, "Apparatus for Transmitting Electrical Energy", *US Patent 1'119'732* (Application filed: 18 January 1902; renewed: 04 May 1907; Patented: 01 December 1914)
- [4] TESLA Nikola, "The Peoples Forum", *New York World* (19 May 1907); reprinted in [12]
- [5] TESLA Nikola, "Famous Scientific Illusions", *Electrical Experimenter* (February 1919); reprinted in [12] 192-199
- [6] TESLA Nikola, "The Magnifying Transmitter", *Electrical Experimenter* (June 1919) 112-113, 148, 173, 176-178; reprinted in [13] 69-75
- [44] WASER André, „The Puzzling Nature – Die rätselhafte Natur“, *AWVerlag* (May 1996) 126
- [45] WASER André, „On Electrodynamics of uniformly moving charges“, [www.andre-waser.ch](http://www.andre-waser.ch) (28 June 2000)
- [46] WASER André, „Force of a HERTZ dipole on a stationary charge“, [www.andre-waser.ch](http://www.andre-waser.ch) (28 June 2000)
- [47] WASER André, „Elektrische Skalarwellen: Review zum Experiment von Prof. Dr. Konstantin Meyl“, *raum&zeit* **107** (August 2000) 46-54
- [48] WASER André, „Nikola Tesla's Radiations and the Cosmic Rays“, *AW-Verlag*, [www.andre-waser.ch](http://www.andre-waser.ch) (29 July 2000)
- [49] YOST Charles A., "The Tesla Experiment – Lightning & Earth Electrical Resonance", *Tesla Book Company, Chula Vista, CA-91912* (1983)



Figure 9: TESLA in his New York laboratory. Has for example be published 1897 in *Electrical Review* (New York and London).

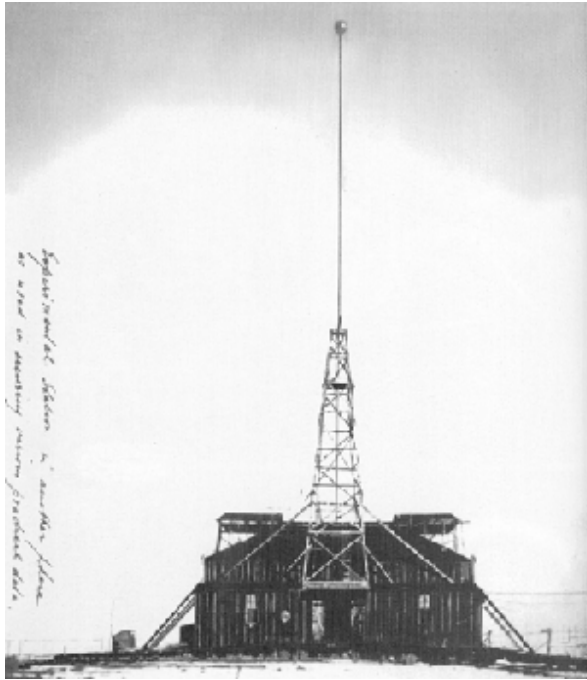

Figure 10: TESLA's Colorado Springs experiment in 1899. The metal ball (~75cm diameter) can be moved in height up to 50 meter about ground.



Figure 11: The skilnet of the first TESLA plant (constructed ~1901-1903) for the transmission of energy and broadcasting signals in Wardencliffe, Long Islands, New York. It was never completed.