

Noise source modeling for cyclostationary noise analysis in large-signal device operation

Original

Noise source modeling for cyclostationary noise analysis in large-signal device operation / Bonani, Fabrizio; DONATI GUERRIERI, Simona; Ghione, Giovanni. - In: IEEE TRANSACTIONS ON ELECTRON DEVICES. - ISSN 0018-9383. - ED-49:(2002), pp. 1640-1647. [10.1109/TED.2002.802638]

Availability:

This version is available at: 11583/1499327 since:

Publisher:

IEEE

Published

DOI:10.1109/TED.2002.802638

Terms of use:

openAccess

This article is made available under terms and conditions as specified in the corresponding bibliographic description in the repository

Publisher copyright

(Article begins on next page)

Noise Source Modeling for Cyclostationary Noise Analysis in Large-Signal Device Operation

Fabrizio Bonani, *Senior Member, IEEE*, Simona Donati Guerrieri, *Member, IEEE*, and Giovanni Ghione, *Senior Member, IEEE*

Abstract—Starting from the analysis of fundamental noise sources in large-signal (LS) periodic operation, a system theory approach is proposed for the modeling of colored noise sources in devices and circuits driven in LS conditions. According to this interpretation, colored sources are generated by low-pass filtering and amplitude modulation of a white unit Gaussian process. The order of the modulation and filtering steps leads to two different (albeit coincident in small-signal conditions) LS noise sources. Through the analysis of GR noise in physics-based device simulation, it is shown that only one modulation scheme (based on low-pass filtering followed by amplitude modulation) is consistent with the fundamental approach. This result also applies to $1/f$ noise mechanisms when $1/f$ fluctuations derive from population fluctuations.

Index Terms—Circuit noise, microwave devices, nonlinear systems, semiconductor device modeling, semiconductor device noise.

I. INTRODUCTION

THE STRONG industrial interest in the design and optimization of RF analog systems has recently fostered a great deal of work in developing accurate and reliable noise modeling approaches, both at the circuit [1]–[4] and device [5]–[8] levels. In RF systems circuits and devices are often operated in large-signal (LS), (quasi-) periodic conditions [5], e.g., as in power amplifiers, mixers, frequency multipliers, and oscillators. This has a strong impact on the statistical properties of the stochastic processes exploited for the description of noise, since the time-varying nature of the operating point makes such processes no longer stationary but rather *cyclostationary* [10], and therefore described in the frequency domain by the so-called sideband correlation matrix (SCM) [5], [6].

Furthermore, the time-varying and nonlinear nature of the system causes frequency conversion effects to take place, thus making a proper description of nonwhite noise, such as $1/f$ fluctuations, extremely important to assess circuit and device RF performances; frequency conversion effects were already observed experimentally by van der Ziel [9] with reference to large-signal $1/f$ noise in a linear resistor. This issue is also fundamental in the development of circuit-oriented large-signal noise models derived by properly extending closed-form small-signal noise models (see, e.g., [1], [3]).

From a device modeling standpoint, the basic Technology CAD technique for noise analysis, at least for nonautonomous applications, consists of two steps [6], [5]. First, the LS noiseless device operating point is evaluated in the frequency domain by applying the harmonic balance technique to the discretized device physical model, e.g., the bipolar drift-diffusion set of partial differential equations (PDE). In the second step, zero-average stochastic forcing terms representing the so-called *microscopic noise sources* [6] are added to the model equations; such sources are assumed to linearly perturb the noiseless operating point. In order to evaluate the correlation spectra of the terminal noise generators, to be exploited in circuit-oriented device modeling, the microscopic noise sources are finally propagated to the device terminals by proper Green's functions [6], whose numerical evaluation is discussed in detail in [5].

While the LS modeling of microscopic noise sources being white in small-signal regime is well established, see, e.g., [5], the issue still is open for noise mechanisms showing, in small signal, a colored spectrum, such as generation–recombination (GR) and $1/f$ noise. Indeed, the same issue arises in circuit-oriented noise modeling in LS operation [3]. According to the discussion in [1], circuit cyclostationary noise analysis is typically based on describing the device noise generators pertaining to each circuit element by means of a modulation of the small-signal expression for such noise generators, that is, in general, frequency dependent. As in the case of the colored microscopic noise sources, also at a circuit level, the modulation scheme is not a settled issue.

This paper presents a general discussion on colored noise source modeling in LS operation, starting from a system theory approach, with an aim at identifying a reliable modeling methodology that can be applied both in circuit and device cyclostationary noise analysis. The focus of this paper is the derivation of the LS microscopic noise sources of GR noise, chosen as a paradigm since it can be described, in small-signal conditions, by exploiting both (exact) white population fluctuations and approximate equivalent Lorentzian current density sources [11].

The paper is organized as follows. Section II presents a critical discussion on noise sources in LS operation, while Section III is devoted to the description of two alternative phenomenological modeling approaches for colored noise sources, derived by extending results previously obtained for circuit analysis [3]. Section IV considers in detail the case of GR fluctuations and presents a novel rigorous derivation of the approximate equivalent current density sources in LS conditions. The phenomenological modeling approaches for colored sources are

Manuscript received January 30, 2002; revised June 5, 2002. The review of this paper was arranged by Editor M. J. Deen.

F. Bonani, and G. Ghione are with the Dipartimento di Elettronica and INFN Unità Torino Politecnico, Politecnico di Torino, 10129 Torino, Italy.

S. D. Guerrieri is with the Dipartimento di Elettronica, Politecnico di Torino, 10129 Torino, Italy.

Publisher Item Identifier 10.1109/TED.2002.802638.

validated (for the GR case) against the exact (fundamental) approach in Section V, and Section VI is devoted to the conclusions. Finally, the Appendix summarizes the main results on cyclostationary processes and their filtering through linear periodically time-varying (LPTV) systems.

II. NOISE SOURCES IN LARGE-SIGNAL OPERATION

Within the framework of classical PDE-based device modeling, e.g., the drift-diffusion model, the noise sources, customarily assumed to be spatially uncorrelated [6], [12], are expressed as population fluctuations or current density fluctuations. In the first case, a scalar source is considered homogeneous to a recombination rate: this is typically the case of fundamental GR noise sources [11], which are described, in small-signal conditions, by white stochastic processes. The vector current density fluctuations on the other hand can be (in small-signal operation) either white (for diffusion-thermal-noise) or colored for approximate equivalent GR (Lorentzian shape) or $1/f$ noise [6].

In LS operation, a proper description has to be provided for the microscopic noise sources. First, let us address the case of fluctuations physically related to the fast microscopic dynamics of free carriers, and therefore modeled, in small-signal conditions, by white processes (hereafter denoted as white sources). To fix the ideas, let us consider the simple case of a white scalar source $\gamma(t)$ (e.g., fundamental GR noise) with small-signal spectrum $S_{\gamma,\gamma} = f^2(\mathbf{r})$, where function $f(\mathbf{r})$ contains all the information on the noiseless device steady-state (for GR noise, it is related to the sum of the generation and recombination rates). From a system theory standpoint, we can interpret $\gamma(t)$ as the output of a time-invariant linear system that multiplies by $f(\mathbf{r})$ a unit white input Gaussian process $\eta(t)$, i.e., $\gamma(t) = f(\mathbf{r})\eta(t)$. In fact, $S_{\gamma,\gamma}(\omega) = f^2(\mathbf{r})S_{\eta,\eta}(\omega)$, where by definition, $S_{\eta,\eta}(\omega) = 1$.

In LS conditions, the device working point becomes periodically time-varying (with fundamental angular frequency $\omega_0 = 2\pi f_0$), thus giving rise to a modulation of the noise sources resulting into their conversion into cyclostationary processes (see the discussion in [6]). Since white sources result from fast microscopic scattering processes (either intraband or interband), whose timeconstants are of the order of less than 1 ps, such a modulation can be assumed to be instantaneous, at least up to frequencies of the order of 100 GHz. From a pure system standpoint, this amplitude modulation can be modeled as the passage of the unit white Gaussian process $\eta(t)$ through a memoryless LPTV system, with impulse response as described in the Appendix [3]. For the white source $\gamma(t)$, function f is transformed into a periodical time-dependent factor $f(\mathbf{r}, t)$ characterized by harmonic (Fourier) components $f_n(\mathbf{r})$, so that the noise source $\gamma(t) = f(\mathbf{r}, t)\eta(t)$ becomes cyclostationary and the corresponding SCM can be easily derived by (30) and (24)

$$(S_{\gamma,\gamma}(\omega))_{k,l} = g_{k-l}(\mathbf{r}) \quad (1)$$

where $g_m(\mathbf{r})$ is the m th harmonic component of $g(\mathbf{r}, t) = f^2(\mathbf{r}, t)$, and ω is the sideband (angular) frequency (see also the Appendix). This is exactly the approach exploited in [5]

to extract the expressions of LS microscopic noise sources for diffusion and fundamental GR noise. The GR case will also be discussed in detail in the following Section IV.

The next step is to extend the previous discussion to the case of noise sources described, in small-signal operation, by a colored spectrum (colored sources). In physics-based noise simulation these are basically the approximate equivalent GR and $1/f$ noise, which are extremely important in RF applications due to the frequency conversion effects related to both time-varying and nonlinear device operation. As discussed in Section IV, the LS microscopic noise source for equivalent GR noise can be extracted in a rigorous way in an homogeneous sample, but this is not the case in more complex devices or for $1/f$ noise. Therefore, a general procedure to extract the expression of the microscopic noise spectra in the LS case still has to be found. The aim of this paper is to discuss two phenomenological modeling approaches starting from the bare knowledge of the small-signal colored noise sources: the idea is to generalize to the case of device simulation a methodology already proposed for circuit analysis in [1] and discussed in [3]. This should make possible to develop a unified approach capable of handling both the colored microscopic noise sources for device simulation, and the modulation of small-signal noise models at a circuit level.

III. A SYSTEM APPROACH TO NOISE SOURCE MODELING

Let us consider two scalar¹ correlated noise sources $\gamma_1(t)$ and $\gamma_2(t)$ characterized, in small-signal conditions, by colored correlation spectra expressed as

$$S_{\gamma_i,\gamma_i}(\omega) = [f^{(i)}(\mathbf{r})]^2 |\tilde{h}_i(\omega)|^2 \quad (2)$$

$$S_{\gamma_i,\gamma_j}(\omega) = f^{(i)}(\mathbf{r})f^{(j)}(\mathbf{r})\tilde{h}_i(\omega)\tilde{h}_j^*(\omega) \quad (3)$$

where $i, j = 1, 2$, $\tilde{h}_i(\omega)$ denotes the Fourier transform of the impulse response $h_i(t)$ of a properly defined linear time-invariant system, and where functions $f^{(i)}(\mathbf{r})$ contain all the information on the local operating point of the device. A typical example is given by the approximate equivalent Lorentzian sources for GR noise [11]. As discussed in the previous section, in LS operation, the working point becomes periodically time-varying, and the factors $f^{(i)}$ become time-dependent, thus modulating the fluctuation processes. Following the discussion in [3], we can phenomenologically extend to LS operation expressions (2) and (3) according to two possible system interpretations.

- The input unit white process is first amplitude modulated by $f^{(i)}(\mathbf{r}, t)$ and then filtered by the linear system with impulse response $h_i(t)$ (see Fig. 1). This approach will be denoted as modulation+filtering (MF).
- The input unit white process is first filtered by $h_i(t)$ and then amplitude modulated by $f^{(i)}(\mathbf{r}, t)$ (see Fig. 2). This approach will be denoted as filtering+modulation (FM).

The SCM of the two sources can be evaluated by application of (24)–(28), exploiting the intermediate stochastic processes $\alpha_i(\mathbf{r}, t)$ and $\beta_i(t)$ defined in Figs. 1 and 2. In the MF case,

¹The extension to vector sources is straightforward.

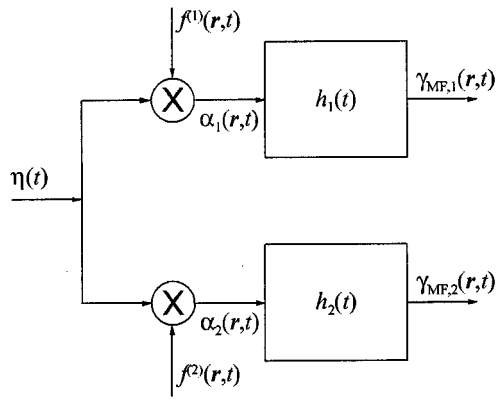

Fig. 1. System interpretation of the modulation of the microscopic noise sources: first amplitude modulation, then filtering (MF).

(30) allows first to evaluate the SCM of the intermediate process $\alpha_i(\mathbf{r}, t)$, and from (28) and (24), we obtain

$$(\mathcal{S}_{\gamma_{MF,i}, \gamma_{MF,j}}(\omega))_{k,l} = \tilde{h}_i(\omega + k\omega_0) g_{k-l}^{(i,j)}(\mathbf{r}) \tilde{h}_j^*(\omega + l\omega_0) \quad (4)$$

where $g_n^{(i,j)}(\mathbf{r})$ is the n th Fourier component of the periodic function $g^{(i,j)}(\mathbf{r}, t) = f^{(i)}(\mathbf{r}, t) f^{(j)}(\mathbf{r}, t)$.

On the other hand, in the FM scheme, the intermediate process $\beta_i(\mathbf{r}, t)$ is stationary with spectrum given by (29). By further applying (27) and (24), the SCM of the modulated sources results as

$$(\mathcal{S}_{\gamma_{FM,i}, \gamma_{FM,j}}(\omega))_{k,l} = \sum_{n=-\infty}^{+\infty} f_n^{(i)}(\mathbf{r}) f_{k-l-n}^{(j)}(\mathbf{r}) \cdot \tilde{h}_i[\omega + (k-n)\omega_0] \tilde{h}_j^*[\omega + (k-n)\omega_0] \quad (5)$$

where $f_n^{(i)}(\mathbf{r})$ is the n th Fourier component of the periodic function $f^{(i)}(\mathbf{r}, t)$.

Notice that (4) and (5) both reduce to (1) for noise sources which are white in small-signal conditions. In fact, in this case $\tilde{h}_i(\omega) = 1$ and we have

$$\begin{aligned} (\mathcal{S}_{\gamma_{MF,i}, \gamma_{MF,j}}(\omega))_{k,l} &= (\mathcal{S}_{\gamma_{FM,i}, \gamma_{FM,j}}(\omega))_{k,l} = g_{k-l}^{(i,j)}(\mathbf{r}) \\ &= \sum_{n=-\infty}^{+\infty} f_n^{(i)}(\mathbf{r}) f_{k-l-n}^{(j)}(\mathbf{r}). \end{aligned} \quad (6)$$

In the colored case, the two approaches, as already noticed in [3], [6], lead to quite different behaviors for the modulated sources. This is due to the low pass nature of the filtering transfer functions $\tilde{h}_i(\omega)$, whose corner frequency is, at least in RF applications, typically much lower than the operating fundamental frequency f_0 . In fact, the MF scheme (4) leads to $(\mathcal{S}_{\gamma_{MF,i}, \gamma_{MF,j}}(\omega))_{k,l} = 0$ unless $k = l = 0$, and in this case one has $(\mathcal{S}_{\gamma_{MF,i}, \gamma_{MF,j}}(\omega))_{0,0} = \tilde{h}_i(\omega) g_0^{(i,j)}(\mathbf{r}) \tilde{h}_j^*(\omega)$. In other words, the noise source is modulated only by the dc component of the working point. The approach exploited for FET LS noise analysis by Cappy *et al.* [13], [14] can be considered as a particular case of the MF scheme.

The FM scheme, instead, leads to sources with a SCM whose elements are all different from zero. In fact, in (5) due to the term in the summation with $n = k$, there is always an addend

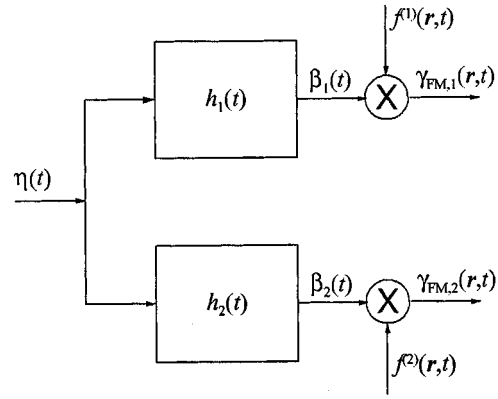

Fig. 2. System interpretation of the modulation of the microscopic noise sources: first filtering, then amplitude modulation (FM).

where the low-pass filtering functions are calculated in ω . This gives a contribution to the SCM element provided that the corresponding harmonic components of the working point are different from zero, i.e., the system is driven in nonlinear operation. Notice that the FM scheme is proposed in [1] for circuit-oriented large-signal device modeling, and is widely exploited within the field of circuit-oriented simulations.

It should be stressed that the previous remarks are strictly related to the assumptions that the filtering function is low-pass and that its bandpass is much lower than the driving signal frequency f_0 .

This phenomenological, system-oriented discussion does not give any insight on which of the two schemes is better suited for noise analysis: in the next section, we shall consider physics-based GR noise analysis, that will provide a basis for the comparison of the two approaches.

IV. FUNDAMENTAL AND PHENOMENOLOGICAL GR NOISE SOURCES IN LS OPERATION

GR noise is a viable candidate as a validation tool for the approaches described in Section III, since two different models for the microscopic sources, fully equivalent in homogeneous samples, are available [11]. Moreover, phenomenological noise sources can be derived by modulation of the small-signal approximate equivalent noise source according to the two schemes outlined in Section III.

A. The Fundamental Sources

Let us consider, for the sake of simplicity, a band-to-band GR process. The corresponding population fluctuation sources are described by scalar processes γ_n and γ_p added as forcing terms to both continuity equations in a bipolar drift-diffusion model

$$\frac{\partial n}{\partial t} = \frac{1}{q} \nabla \cdot \mathbf{J}_n - (R - G) + \gamma_n \quad (7)$$

$$\frac{\partial p}{\partial t} = -\frac{1}{q} \nabla \cdot \mathbf{J}_p - (R - G) + \gamma_p \quad (8)$$

where $n(\mathbf{r}, t)$ and $p(\mathbf{r}, t)$ are the electron and hole carrier density distributions; $\mathbf{J}_n = -qn\mu_n \nabla \psi + qD_n \nabla n$ and $\mathbf{J}_p = -qp\mu_p \nabla \psi - qD_p \nabla p$ are the electron and hole current densities; $\psi(\mathbf{r}, t)$ is the electrostatic potential, μ and D are the

carrier mobility and diffusivity, and G and R are the generation and recombination rates.

The scalar forcing terms γ_n and γ_p represent the fundamental microscopic noise sources for GR noise. In small-signal conditions, these are spatially uncorrelated and white, with correlation spectra

$$S_{\gamma_\alpha, \gamma_\beta}(\omega) = 2[G(\mathbf{r}) + R(\mathbf{r})]\delta(\mathbf{r} - \mathbf{r}') \quad (9)$$

where $G(\mathbf{r})$ and $R(\mathbf{r})$ are evaluated in the dc noiseless device working point. On the contrary, in LS conditions such sources γ_n and γ_p are amplitude modulated according to (1)

$$(\mathbf{S}_{\gamma_\alpha, \gamma_\beta}(\omega))_{k,l} = 2[G_{k-l}(\mathbf{r}) + R_{k-l}(\mathbf{r})]\delta(\mathbf{r} - \mathbf{r}') \quad (10)$$

where G_n and R_n are the n th harmonic components of the corresponding rate evaluated into the LS steady state.

B. The Equivalent Fundamental Sources

An alternative modeling approach makes use of approximate equivalent microscopic noise sources expressed as current density (vector) fluctuations added to (7) and (8), and eliminating the scalar sources from the system. The derivation of such vector sources is carried out in small-signal operation and homogeneous conditions following [11]. The divergence terms in (7) and (8), are set to zero, and the resulting equations are linearized and written in the frequency domain

$$j\omega\delta\tilde{n} = -B_n\delta\tilde{n} - B_p\delta\tilde{p} + \tilde{\gamma}_n \quad (11)$$

$$j\omega\delta\tilde{p} = -B_n\delta\tilde{n} - B_p\delta\tilde{p} + \tilde{\gamma}_p \quad (12)$$

where we have defined the frequency-domain carrier density fluctuations $\delta\tilde{n}$, $\delta\tilde{p}$, and where $B_\alpha = \partial(R-G)/\partial\alpha$ (the inverse of carrier α lifetime, $\alpha = n, p$) are evaluated in the dc working point. This linear system can be solved for $\delta\tilde{n}$ and $\delta\tilde{p}$, so as to calculate the corresponding current density fluctuations $\delta\tilde{\mathbf{J}}_\alpha = q\mathbf{v}_\alpha\delta\tilde{\alpha}$ ($\alpha = n, p$, and \mathbf{v}_α is the velocity of carrier α evaluated in the dc noiseless steady state), whose correlation spectrum is Lorentzian

$$\begin{aligned} \mathbf{S}_{\delta\mathbf{J}_\alpha, \delta\mathbf{J}_\beta}(\omega) &= \langle \delta\tilde{\mathbf{J}}_\alpha \delta\tilde{\mathbf{J}}_\beta^\dagger \rangle \\ &= \mathbf{v}_\alpha \mathbf{v}_\beta \frac{2q^2\tau_{\text{eq}}^2}{1 + \omega^2\tau_{\text{eq}}^2} (G + R)\delta(\mathbf{r} - \mathbf{r}') \end{aligned} \quad (13)$$

where $\tau_{\text{eq}} = (B_n + B_p)^{-1}$, $\langle \cdot \rangle$ denotes the ensemble average, and \dagger is the Hermitian conjugate. The fundamental and Lorentzian sources are fully equivalent only for strictly homogeneous semiconductor samples, as discussed in [11].

A similar procedure can also be carried out in periodic LS operation, by exploiting the sideband formalism and the conversion matrix approach described in [6], [5]. By linearizing, in a homogeneous sample (7) and (8) around the instantaneous working point, one gets

$$j\Omega \cdot \delta\tilde{\mathbf{n}} = -\mathbf{B}_n \cdot \delta\tilde{\mathbf{n}} - \mathbf{B}_p \cdot \delta\tilde{\mathbf{p}} + \tilde{\gamma}_n \quad (14)$$

$$j\Omega \cdot \delta\tilde{\mathbf{p}} = -\mathbf{B}_n \cdot \delta\tilde{\mathbf{n}} - \mathbf{B}_p \cdot \delta\tilde{\mathbf{p}} + \tilde{\gamma}_p \quad (15)$$

where Ω is a matrix collecting the sideband frequencies, $\delta\tilde{\mathbf{n}}$ and $\delta\tilde{\mathbf{p}}$ are vectors of the sideband amplitudes of the induces carrier

variations, $\tilde{\gamma}_\alpha$ is the vector of sideband components for the modulated fundamental noise sources. Finally, \mathbf{B}_α are conversion matrices related to the linearization of the net recombination rate evaluated into the LS working point [5]. Again, from (14) and (15) we can explicitly calculate the sideband carrier density fluctuations and exploit them to evaluate the corresponding current densities

$$\delta\tilde{\mathbf{J}}'_\alpha = q\mathbf{v}_\alpha \cdot \delta\tilde{\alpha}, \quad \alpha = n, p \quad (16)$$

where \mathbf{v}_α is now a conversion matrix related to the carrier velocity in the steady-state. The corresponding SCM is derived as $\langle \delta\tilde{\mathbf{J}}'_\alpha (\delta\tilde{\mathbf{J}}'_\beta)^\dagger \rangle$, leading to a somewhat complex expression, which is omitted for brevity. This source will be called ‘‘equivalent fundamental.’’ As for the small-signal case, the fundamental and equivalent fundamental sources are exact in homogeneous conditions.

C. The Phenomenological Sources

As discussed in Section III, a further LS modeling approach is derived by modulating, according to the MF or FM scheme, the Lorentzian small-signal source (13). The resulting noise sources will be called ‘‘MF’’ and ‘‘FM,’’ respectively.

The expressions for the modulated MF and FM sources for GR noise are derived starting from (13), and then making use of the modulated expressions (4) and (5). For the sake of simplicity, we shall write the result in the case of one-dimensional models only. The extension to the multidimensional case is straightforward. The small-signal expression is factorized by defining the filtering function

$$\tilde{h}(\omega) = \frac{\sqrt{2}q\tau_{\text{eq}}}{\sqrt{1 + \omega^2\tau_{\text{eq}}^2}} \quad (17)$$

and the modulation functions

$$f_\alpha(\mathbf{r}, t) = v_\alpha(\mathbf{r}, t) \sqrt{G(\mathbf{r}, t) + R(\mathbf{r}, t)}, \quad \alpha = n, p. \quad (18)$$

We also define the auxilliary function $g_{\alpha,\beta}(\mathbf{r}, t) = f_\alpha(\mathbf{r}, t)f_\beta(\mathbf{r}, t)$.

In the MF case, (4) yields

$$\begin{aligned} (\mathbf{S}_{\delta\mathbf{J}_{\alpha,\text{MF}}, \delta\mathbf{J}_{\beta,\text{MF}}}(\omega))_{k,l} \\ = \frac{2q^2\tau_{\text{eq}}^2 (g_{\alpha,\beta}(\mathbf{r}))_{k-l}}{\sqrt{[1 + (\omega + k\omega_0)^2\tau_{\text{eq}}^2] [1 + (\omega + l\omega_0)^2\tau_{\text{eq}}^2]}} \end{aligned} \quad (19)$$

where $(g_{\alpha,\beta}(\mathbf{r}))_m$ is the m th harmonic component of the periodic function $g_{\alpha,\beta}(\mathbf{r}, t)$.

The application of the FM scheme leads to (5), which in turn results into

$$\begin{aligned} (\mathbf{S}_{\delta\mathbf{J}_{\alpha,\text{FM}}, \delta\mathbf{J}_{\beta,\text{FM}}}(\omega))_{k,l} \\ = \sum_{m=-\infty}^{+\infty} \frac{2q^2\tau_{\text{eq}}^2 (f_\alpha(\mathbf{r}))_m (f_\beta(\mathbf{r}))_{k-l-m}}{1 + [\omega + (k-m)\omega_0]^2\tau_{\text{eq}}^2} \end{aligned} \quad (20)$$

where $(f_\alpha(\mathbf{r}))_m$ is the m th harmonic component of the periodic function $f_\alpha(\mathbf{r}, t)$.

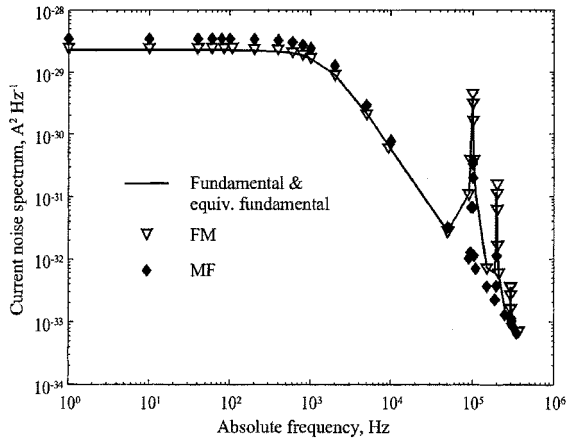

Fig. 3. Absolute frequency dependence of the diagonal elements of the SCM for the short-circuit GR noise current.

V. DISCUSSION

In order to compare the modeling approaches discussed previously, we have simulated a uniformly doped silicon sample long enough to be assumed as homogeneous (inhomogeneity being induced by ohmic contact boundary conditions [11]). The sample was n doped with $N_D = 10^{17} \text{ cm}^{-3}$, and a direct GR process was included in the bipolar drift-diffusion model with minority carrier lifetime $\tau = 0.1 \text{ ms}$. Electron velocity saturation effects, that give rise to nonlinear phenomena in this simple device, were included through the standard Caughey [15] model with low-field mobility $1390 \text{ cm}^2 \text{ V}^{-1} \text{ s}^{-1}$ and saturation velocity 10^7 cm/s , while a constant hole mobility $\mu_p = 470 \text{ cm}^2 \text{ V}^{-1} \text{ s}^{-1}$ was assumed for the sake of simplicity. The sample length was chosen so as to provide a full equivalence of the small-signal fundamental and approximate equivalent noise sources for GR noise, as discussed in [11].

An LS simulation was performed with a dc electric field of 7 kV/cm , close to the threshold field for electron velocity saturation, and with a superimposed ac component of the same amplitude and frequency $f_0 = 100 \text{ kHz}$, so that the sample was driven in nonlinear operation. We included six harmonics plus dc in the noiseless harmonic-balance physical simulation, so as to allow noise calculations for the first three sidebands [5]. In noise analysis, only GR noise sources were considered.

The diagonal elements² of the SCM of the sample short-circuit noise current due to GR fluctuations are shown in Fig. 3 as a function of the absolute frequency. The continuous line results from the fundamental and equivalent fundamental sources, while symbols refer to the phenomenological FM (open triangles) and MF (diamonds) sources. The Lorentzian shape [with corner frequency equal to $1/(2\pi\tau)$] is clearly visible for the dc sideband (sideband 0), while the nonlinear device behavior results into a noise conversion effect to all of the other three sidebands, whose centers are f_0 (sideband 1), $2f_0$ (sideband 2), and $3f_0$ (sideband 3).

The conversion effect is more clearly seen in Fig. 4, where the same SCM elements (for the upper sidebands) are plotted as a function of the sideband frequency, i.e., the distance from each harmonic. The main conclusion of this comparison is that only

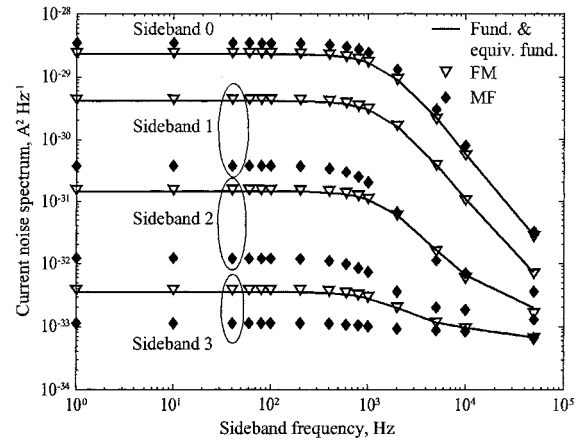

Fig. 4. Sideband frequency dependence of the diagonal elements of the SCM for the short-circuit GR noise current.

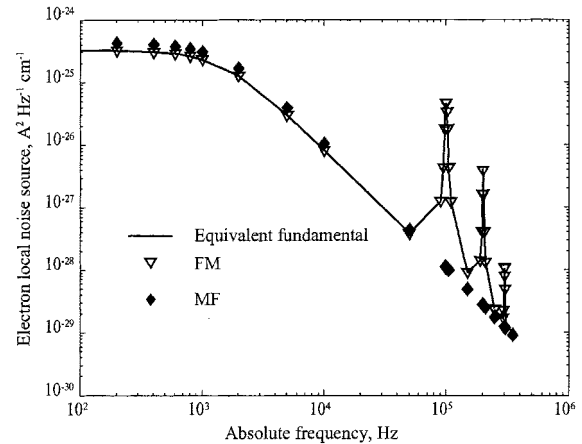

Fig. 5. Absolute frequency dependence of the current density local noise source SCM (diagonal elements), electron-electron correlation component.

the FM scheme gives results in agreement with the fundamental analysis, while the MF approach is incorrect, at least in the case of the GR noise source. In particular, the above discussion suggests that GR noise processes are not, as sometimes assumed [13], [14], modulated *only* by the dc component of the instantaneous device or circuit working point.

A deeper insight on the reason of the discrepancy between the MF approach and the FM and exact ones can be derived from a comparison of the local modulated current density noise sources (which are space-independent in the homogeneous sample), see Figs. 5–7. We can compare only the FM and MF sources to the equivalent fundamental one, since only the latter is a current density fluctuation. In accordance with the remarks in Section III, the MF scheme does not produce any frequency conversion in the microscopic noise sources. This means that, in this case, the conversion effects shown in Figs. 3 and 4 are due *only* to the Green's functions propagating the microscopic sources to the terminal fluctuations. The FM approach, which is in agreement with the equivalent fundamental sources, already exhibits frequency conversion in the microscopic noise source and therefore leads to a stronger conversion effects on the terminal fluctuations.

A further remark concerns the relationship of the conversion behavior of the FM and exact noise sources with the linear or

²The same kind of results hold for the off-diagonal terms of the SCM.

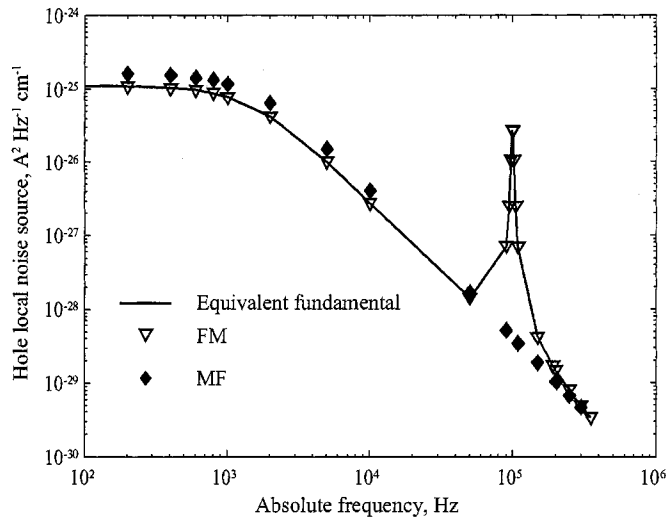

Fig. 6. Absolute frequency dependence of the current density local noise source SCM (diagonal elements), hole–hole correlation component.

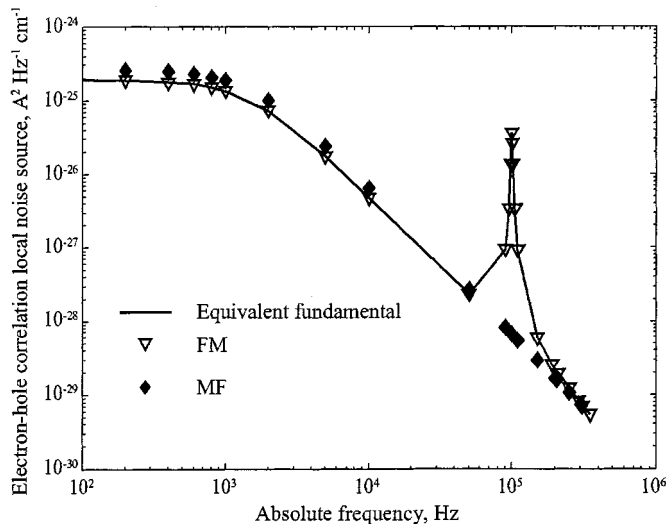

Fig. 7. Absolute frequency dependence of the current density local noise source SCM (diagonal elements), electron–hole correlation component.

nonlinear (field-dependent) model for the carrier velocity. In fact, the electron–electron SCM (Fig. 5) shows conversion to all sidebands since the electron transport model is nonlinear, while the hole–hole (Fig. 6) and electron–hole (Fig. 7) SCM only exhibit conversion to the fundamental frequency. This is consistent with the linear model implemented for hole transport (constant mobility), which confines the conversion effect to the time-varying nature of the operating point. Following this discussion, only one noise sideband (caused by the modulation effect of the time-varying working point on colored microscopic noise sources) should be detected, in LS operation, in the terminal fluctuation spectrum of a linear resistor, thus confirming van der Ziel’s experiment [9].

As a final remark, the FM approach to LS noise source modeling is likely to serve as a guideline in extending to LS operation the small-signal expressions of “slow” noise processes. Besides GR, a major interest concerns $1/f$ fluctuations, for which a fundamental white small-signal microscopic source is lacking. In some cases, $1/f$ noise can be traced back to a superposition

of GR spectra with a proper distribution of lifetimes, see the discussion in [16]; if this occurs, the FM modulation scheme can be directly applied to the GR components so as to provide the LS noise source. A more detailed discussion will be presented elsewhere.

VI. CONCLUSION

In this paper, we have presented a thorough discussion on noise source modeling for the cyclostationary noise analysis of devices and circuits operating in periodic LS conditions. Particular stress has been laid on the application to the physics-based LS case of modulation schemes for colored noise sources, taking as a paradigm GR noise analysis, for which a fundamental, exact noise modeling approach is available. As a result of the analysis, only one equivalent noise source modulation scheme, namely the one based on low-pass filtering followed by amplitude modulation, has been found to be consistent with the exact, fundamental approach. This result is expected to apply also to $1/f$ noise mechanisms, at least when the $1/f$ spectrum results from a superposition of population fluctuations, and could also serve as a guideline for LS modeling of colored noise sources at a circuit level.

APPENDIX

This appendix is devoted to a brief introduction to the statistical description and to the filtering through linear systems of cyclostationary stochastic processes. A more detailed discussion can be found in [3], [6]. Let $x(t)$ be a cyclostationary process, i.e., a stochastic process whose mean $m_x(t)$ and correlation function $R_{x,x}(t_1, t_2)$ are periodic in time with period T

$$m_x(t) = \langle x(t) \rangle = m_x(t + T) \quad (21)$$

$$R_{x,x}(t_1, t_2) = \langle x(t_1)x^*(t_2) \rangle = R_{x,x}(t_1 + T, t_2 + T) \quad (22)$$

where $\langle \cdot \rangle$ denotes ensemble average. From these basic definitions, it can be easily shown that such nonstationary processes are characterized by a correlation between those spectral components having the same distance ω from some harmonic of the fundamental (angular) frequency $\omega_0 = 2\pi/T$ [5], [6]: this allows to partition the spectrum into *sidebands*, i.e., neighborhoods of any harmonic $\omega_k = k\omega_0$ characterized by an absolute frequency $\omega_k \pm \omega$. Correspondingly, the correlation spectra between the various sidebands are collected into the process *sideband correlation matrix* $\mathbf{S}_{x,x}(\omega)$. On the other hand, the modified correlation function $\hat{R}_{x,x}(t, \tau) = R_{x,x}(t + \tau/2, t - \tau/2)$ is periodic in t , and can be developed in Fourier series

$$\hat{R}_{x,x}(t, \tau) = \sum_{n=-\infty}^{+\infty} R_{x,x}^{(n)}(\tau) e^{j\omega_n t} \quad (23)$$

where the Fourier coefficients $R_{x,x}^{(n)}(\tau)$ are the process *cyclic correlation functions*. The (k, l) element of the SCM can be expressed as a function of the Fourier transform of the cyclic correlation functions, the *cyclic correlation spectra* $S_{x,x}^{(n)}(\omega)$, as [6]

$$(\mathbf{S}_{x,x}(\omega))_{k,l} = S_{x,x}^{(k-l)}\left(\omega + \frac{k+l}{2}\omega_0\right). \quad (24)$$

Concerning linear filtering, let us consider a linear periodically time-varying (LPTV) system with impulse response $h(t, u)$ [3], which is periodic with period T : $h(t, u) = h(t + T, u + T)$, so that

$$h(t + \tau, t) = \sum_{n=-\infty}^{+\infty} h^{(n)}(\tau) e^{jn\omega_0 t}. \quad (25)$$

Filtering of a cyclostationary process $x(t)$ through a LPTV system with the same period results again in a cyclostationary process $y(t)$, characterized by [3]

$$S_{y,y}^{(k)}(\omega) = \sum_{n,m=-\infty}^{+\infty} \tilde{h}^{(n)}\left(\omega + \frac{k}{2}\omega_0\right) S_{x,x}^{(k-(n-m))}\left(\omega - \frac{n+m}{2}\omega_0\right) \tilde{h}^{(m)*}\left(\omega - \frac{k}{2}\omega_0\right) \quad (26)$$

where $\tilde{h}^{(n)}(\omega)$ is the Fourier transform of $h^{(n)}(\tau)$. If the input process $x(t)$ is stationary, and therefore only the zeroth order cyclic correlation spectrum is present, and the filtering system is LPTV, $y(t)$ is cyclostationary with cyclic spectra given by (26) calculated for $k - (n - m) = 0$

$$S_{y,y}^{(k)}(\omega) = \sum_{m=-\infty}^{+\infty} \tilde{h}^{(m+k)}\left(\omega + \frac{k}{2}\omega_0\right) S_{x,x}\left(\omega - \frac{2m+k}{2}\omega_0\right) \tilde{h}^{(m)*}\left(\omega - \frac{k}{2}\omega_0\right). \quad (27)$$

On the other hand, if $x(t)$ is cyclostationary and $h(t, u) = h(t - u)$ is time invariant, $y(t)$ is cyclostationary and (26) can be exploited by considering $m = n = 0$

$$S_{y,y}^{(k)}(\omega) = \tilde{h}\left(\omega + \frac{k}{2}\omega_0\right) S_{x,x}^{(k)}(\omega) \tilde{h}^*\left(\omega - \frac{k}{2}\omega_0\right). \quad (28)$$

A trivial case occurs when $x(t)$ is stationary and $h(t, u) = h(t - u)$ is time invariant; in this case $y(t)$ is stationary with spectrum

$$S_{y,y}(\omega) = \left|\tilde{h}(\omega)\right|^2 S_{x,x}(\omega). \quad (29)$$

Finally, let us consider an LPTV system made of a multiplication of the input times a real periodic function $m(t)$, i.e., an amplitude modulation $y(t) = m(t)x(t)$. In this case, the impulse response is $h(t, u) = m(t)\delta(t - u)$, and therefore $h^{(n)}(\tau) = m_n\delta(\tau)$, where m_n is the n th Fourier component of $m(t)$. This means that $\tilde{h}^{(n)}(\omega) = m_n$. If $x(t)$ is a unit white noise, $S_{x,x}(\omega) = 1$ and (27) yields

$$S_{y,y}^{(k)}(\omega) = \sum_{n=-\infty}^{+\infty} m_{n+k} m_n^* = M_k \quad (30)$$

where M_k is the k th harmonic component of function $M(t) = m^2(t)$.

REFERENCES

- [1] V. Rizzoli, F. Mastri, and D. Masotti, "General noise analysis of nonlinear microwave circuits by the piecewise harmonic balance technique," *IEEE Trans. Microwave Theory Tech.*, vol. 42, pp. 807–819, May 1994.

- [2] J. Roychowdhury, D. Long, and P. Feldmann, "Cyclostationary noise analysis of large RF circuits with multitone excitations," *IEEE J. Solid-State Circuits*, vol. 33, pp. 324–336, Mar. 1998.
- [3] A. Demir and A. Sangiovanni-Vincentelli, *Analysis and Simulation of Noise in Nonlinear Electronic Circuits and Systems*. Boston, MA: Kluwer, 1998.
- [4] A. Demir, A. Mehrotra, and J. Roychowdhury, "Phase noise in oscillators: A unifying theory and numerical methods for characterization," *IEEE Trans. Circuits Syst. I*, vol. 47, pp. 655–674, May 2000.
- [5] F. Bonani, S. D. Guerrieri, G. Ghione, and M. Pirola, "A TCAD approach to the physics-based modeling of frequency conversion and noise in semiconductor devices under large-signal forced operation," *IEEE Trans. Electron Devices*, vol. 48, pp. 966–977, May 2001.
- [6] F. Bonani and G. Ghione, *Noise in Semiconductor Devices. Modeling and Simulation*. Heidelberg, Germany: Springer-Verlag, 2001.
- [7] F. Danneville, G. Dambrine, and A. Cappy, "Noise modeling in MESFET and HEMT mixers using a uniform noisy line model," *IEEE Trans. Electron Devices*, vol. 45, pp. 2207–2212, Oct. 1998.
- [8] F. Danneville, B. Tamen, A. Cappy, J.-B. Juraver, O. Llopis, and J. Graf-feuil, "Low frequency noise conversion in FET's under nonlinear operation," *Fluctuations Noise Lett.*, vol. 1, no. 3, pp. L189–L194, 2001.
- [9] A. van der Ziel, *Noise in Solid State Devices and Circuits*. New York: Wiley, 1986.
- [10] W. A. Gardner, Ed., *Cyclostationarity in Communications and Signal Processing*. New York: IEEE Press, 1994.
- [11] F. Bonani and G. Ghione, "Generation-recombination noise modeling in semiconductor devices through population or approximate equivalent current density fluctuations," *Solid-State Electron.*, vol. 43, pp. 285–295, 1999.
- [12] J. P. Nougier, "Fluctuations and noise of hot carriers in semiconductor materials and devices," *IEEE Trans. Electron Devices*, vol. 41, pp. 2034–2049, Nov. 1994.
- [13] A. Cappy, F. Danneville, G. Dambrine, and B. Tamen, "Noise analysis in devices under nonlinear operation," *Solid-State Electron.*, vol. 43, pp. 21–26, 1999.
- [14] F. Danneville, A. Cappy, and O. Llopis, "Nonlinear noise in high-frequency devices," in *16th Int. Conf. Noise in Physical Systems and 1/f Noise*, G. Bosman, Ed. Gainesville, FL, Oct. 22–25, 2001, pp. 653–658.
- [15] D. M. Caughey and R. E. Thomas, "Carrier mobilities in silicon empirically related to doping and field," *Proc. IEEE*, vol. 55, pp. 2192–2193, 1967.
- [16] F. N. Hooge, "1/f noise sources," *IEEE Trans. Electron Devices*, vol. 41, pp. 1926–1935, Nov. 1994.



Fabrizio Bonani (SM'02) was born in Torino, Italy, in 1967. He received the Laurea degree (cum laude) and the Ph.D. degree in electronic engineering from Politecnico di Torino, Torino, Italy, in 1992 and 1996, respectively.

Since 1995, he has been with the Electronics Department, Politecnico di Torino, first as a Researcher and since 2001, as an Associate Professor of electronics. His research interests are mainly devoted to the physics-based simulation of semiconductor devices, with special emphasis on the noise analysis of microwave field-effect and bipolar transistors, and to the thermal analysis of power microwave circuits. Part of his research concerns the analysis and simulation of nonlinear dynamical systems. From October 1994 to June 1995, he was with the ULSI Technology Research Department of Bell Laboratories, Murray Hill, NJ, as a Consultant, working on physics-based noise modeling of electron devices.



Simona Donati Guerrieri (M'97) was born in 1969 in Milano, Italy. She received the degree in theoretical physics from the University of Milano in 1993, and the Ph.D. degree in electron devices from the University of Trento, Trento, Italy, in 1999.

She is presently working as a Researcher in the Electronics Department, Politecnico di Torino, Torino, Italy, where she joined the microwave electronics group. Her research interests include the modeling and simulation of microwave solid-state devices, including physics-based noise analysis, and the RF and microwave integrated circuit design.



Giovanni Ghione (SM'94) was born in 1956 in Alessandria, Italy. He graduated (cum laude) in electronic engineering from the Politecnico di Torino, Torino, Italy, in 1981.

In 1983, he was a Research Assistant with Politecnico di Torino, and from 1987 to 1990, he was an Associate Professor with the Politecnico di Milano, Milano, Italy. In 1990, he joined the University of Catania, Catania, Italy, as Full Professor of electronics, and since 1991, he has held the same position at Politecnico di Torino II, Faculty

of Engineering. Since 1981, he has been engaged in Italian and European research projects (ESPRIT 255, COSMIC, and MANPOWER) in the field of active and passive microwave CAD. His present research interests concern the physics-based simulation of active microwave and optoelectronic devices, with particular attention to noise modeling, thermal modeling, and active device optimization. His research interests also include several topics in computational electromagnetics, including coplanar component analysis. He has published more than 150 papers and book chapters in the above fields.

Dr. Ghione is a member of the Editorial Board of the IEEE TRANSACTIONS ON MICROWAVE THEORY AND TECHNIQUES and a member of the Associazione Elettrotecnica Italiana (AEI).