

Nonlinear electric metamaterials

David A. Powell,^{a)} Ilya V. Shadrivov, and Yuri S. Kivshar

Nonlinear Physics Center, Research School of Physics and Engineering, Australian National University, Canberra, Australian Capital Territory 0200, Australia

(Received 26 May 2009; accepted 5 August 2009; published online 24 August 2009)

We propose and design a new type of nonlinear metamaterials exhibiting a resonant electric response at microwave frequencies. By introducing a varactor diode as a nonlinear element within each resonator, we are able to shift the frequency of the electric mode stop band by changing the incident power without affecting the magnetic response. These elements could be combined with the previously developed nonlinear magnetic metamaterials in order to create negative index media with a control over both electric and magnetic nonlinearities. © 2009 American Institute of Physics. [DOI: 10.1063/1.3212726]

A negative index metamaterial usually consists of a composite structure, which simultaneously exhibits negative electric and magnetic responses over some frequency band.¹ Split-ring resonators (SRRs) are the best known elements of structures with a negative magnetic response, and arrays of long wires are commonly used to create a negative electric permittivity.² This approach has the advantage that the broad negative electric response of the wires can relatively easily be overlapped with the narrow-band negative magnetic response of the SRRs. However, long wires are unsuitable for many applications, such as transform optics which require local variations in the unit cell parameters and which may require a nonperiodic arrangement of unit cells. One of the solutions to this problem is the use of electric resonators constructed from two resonant loops having a fundamental mode whereby the total magnetic dipole moment is canceled out, leaving a nonvanishing electric dipole moment.^{3,4} Such structures have been demonstrated in the microwave and terahertz bands, and have been shown to have their response tuned by an optical pump signal.⁵

The ability to engineer the linear response of metamaterials to achieve exotic values of permittivity and permeability is well known, however, their strong field localization also makes them very well suited to exhibiting exotic nonlinear phenomena.^{6–8} This is due to the strong increase in field strength at the resonant frequency and also the local field strength which can be much larger than the average incident field strength. Previous work has shown that individual SRRs can be made tunable and nonlinear by the introduction of diodes with voltage-controlled capacitance,^{9–11} and that such resonators can be combined to create bulk nonlinear metamaterial structures.^{12,13}

Given that the nonlinear shift in resonance results in a very strong nonlinear magnetic response for SRRs, we take a similar approach to the design of nonlinear electric resonators, in order to obtain a strong nonlinear electric response. Our structure is shown in Fig. 1, where two perpendicular sets of boards are introduced to create a relatively isotropic response. Within each resonator, an additional gap is introduced where a varactor diode is placed, introducing additional series capacitance in order to tune the resonant frequency. The lattice period is 11 mm and the resonators are

fabricated on copper-clad FR4 with width and height of 8 mm, track width of 1 mm, outer gaps of 0.4 mm separation, and length of 2.4 mm.

The sample is placed in a parallel plate waveguide and is excited by a vector network analyzer via a monopole probe, with a microwave amplifier included in the system in order to increase the available excitation power, as shown in Fig. 2. As there is a significant ripple and some gain compression in the transmission response of the amplifier, a power calibration is first performed for each desired power level by connecting a power meter to the directional coupler, as shown by the dotted line. In order to know the value of the fields fed to the waveguide, the output of the amplifier is sampled using a directional coupler. The total transmission through the amplifier, waveguide, and metamaterial is then normalized to this quantity, which has largely eliminated artifacts due to the amplifier response.

We measure the transmission response at incident powers of 10, 20, and 30 dBm, as shown in Fig. 3(a). At the lowest incident power (10 dBm), there is negligible tuning of the response by the incident wave, thus the transmission response in this case is essentially linear. The large insertion loss away from resonance is due to the deliberately mismatched receiving probe, which is designed for minimal perturbation of the fields within the structure.

It can be seen that our structure exhibits two resonant stop bands within the measured frequency range. The lower band is due to currents flowing in opposite directions in each of the two rings of the resonator, as shown in Fig. 4(a). This results in two equal magnetic dipoles of opposite orientation, which have a zero net magnetic dipole moment,¹⁴ and a

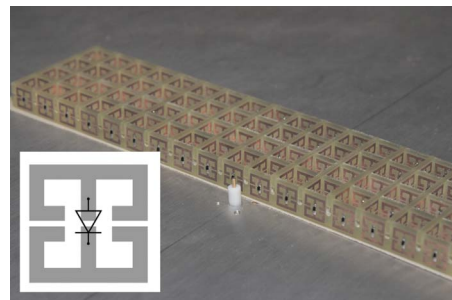

FIG. 1. (Color online) Slab of nonlinear electric metamaterials used in our experiments. The inset shows one structural element.

^{a)}Electronic mail: david.a.powell@anu.edu.au.

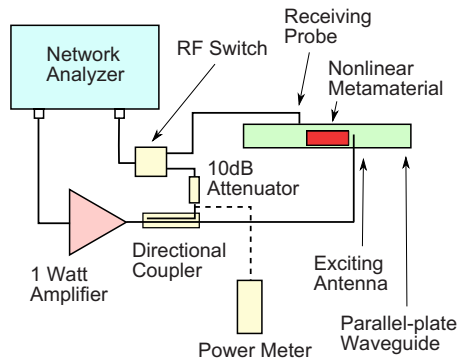

FIG. 2. (Color online) Measurement configuration.

dominant electric dipole moment due to the identical charge accumulation across each gap. Importantly, there is significant net current flowing through the central conductor containing the varactor diode. Thus we see that this resonant frequency is strongly modified by the incident power.

On the other hand, Fig. 3(a) shows that the higher frequency mode does not shift its frequency with a change in the incident power. As can be seen in Fig. 4(b), this mode consists of two current loops flowing in the same direction, thus their magnetic dipole moments add constructively. As the accumulated charges across the gaps have opposite directions, this results in a vanishing electric dipole moment. As there is no net current through the central conductor, the nonlinear response of the varactor diode does not come into play. These mode configurations, and the stop band loca-

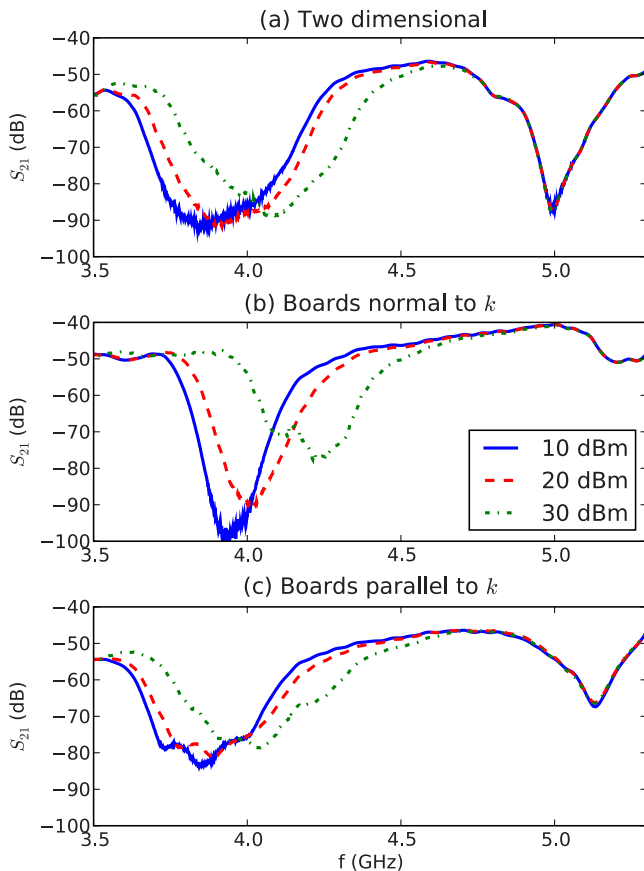

FIG. 3. (Color online) [(a)–(c)] Experimentally measured nonlinear transmission response at incident powers of 10, 20, and 30 dBm for different orientations.

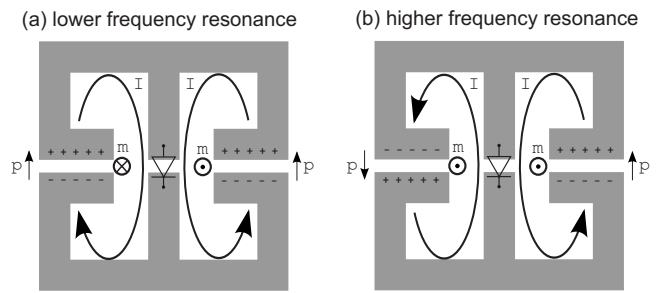

FIG. 4. Resonant modes of the electric resonators, showing the two current loops I and their electric and magnetic dipole moments p and m , respectively.

tions, are confirmed by numerical simulations of transmission performed in CST MICROWAVE STUDIO (Ref. 15) using a single element with electric boundaries in the vertical direction and magnetic boundaries in the horizontal direction.

For comparison, we investigate the two different orientations of the circuit boards individually, i.e., those which are normal to the direction of propagation and those which are parallel to it. The nonlinear transmission responses for these structures are shown in Figs. 3(b) and 3(c), respectively. In both cases a significant nonlinear response still occurs. In the case of the boards being perpendicular to the direction of propagation, the higher frequency magnetic stop band does not exist. This is due to the symmetry of the fields across the gaps and the lack of any magnetic field component normal to the rings. We note that as the experiment uses a cylindrically symmetric source, there is some component of the wavenumber normal to the nominal propagation direction, hence some vestige of the second resonance remains. Also of note is the fact that both resonances are noticeably modified in the isotropic configuration compared to when they are measured separately. This is likely to be due to the strong electrical interaction between the nearest-neighbor boards in the orthogonal directions due to their gaps being in close proximity.

To verify the nature of metamaterial resonances, the most common approach is to consider the reflection and transmission from a finite-thickness slab, which are then inverted to find the equivalent refractive index and impedance, which will reconstruct the observed scattering. However for most metamaterials reported in literature, the permittivity and permeability obtained by this method have nonphysical features, such as violation of conservation of energy.¹⁶ Thus we choose instead to calculate the electric and magnetic dipole moments of the unit cell as a function of frequency, in order to verify the intuitive picture of the nature of these resonances. We take the following definitions of the electric and magnetic dipole moments¹⁷ calculated over the unit cell of volume V due to current density \vec{J} and charge density $\rho = -\nabla \cdot \vec{J} / j\omega$:

$$\vec{p} = \frac{1}{j\omega} \int_V \vec{J}(\vec{x}) d^3x, \tag{1}$$

$$\vec{m} = \frac{1}{2} \int_V \vec{x} \times \vec{J}(\vec{x}) d^3x. \tag{2}$$

From numerical simulations of a single layer of electric resonators, we can readily retrieve the surface currents on the

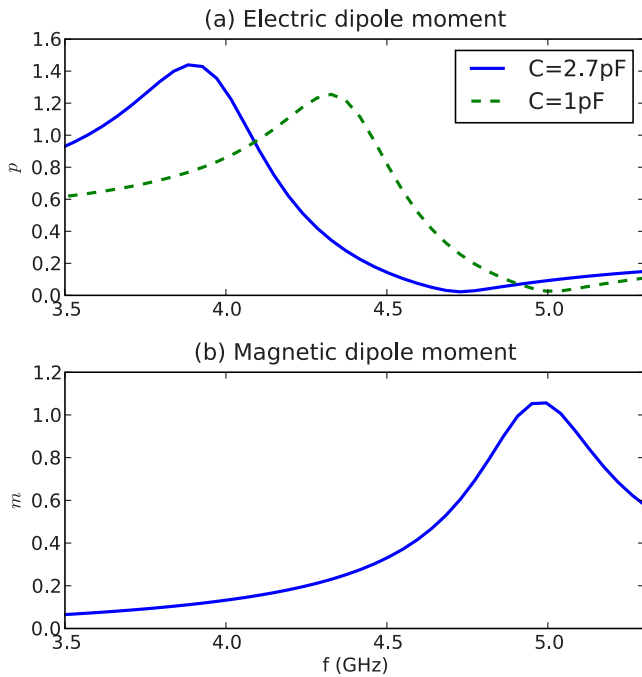

FIG. 5. (Color online) Numerically calculated (a) electric and (b) magnetic dipole moments of the resonator aligned parallel to \bar{k} .

conductors, which we assume to dominate over displacement currents within the dielectrics. We also note that the currents flowing in the waveguide walls should not be included in the calculation, as they represent the response of the images of the unit cell, and thus should be considered as belonging to virtual neighbors. Therefore in deriving Eq. (1) from the definition of the electric dipole moment based on the charge distribution, we neglect the terms corresponding to currents flowing on the boundaries of the unit cell.

With reference to Fig. 4, the dominant electric dipole moment will be in the vertical direction, and the dominant magnetic dipole moment will be oriented out of the page and these components are plotted in the normalized forms $p_y/E_{\text{inc}}\epsilon_0V$ and $m_x/H_{\text{inc}}V$ in Fig. 5. Here the resonator is aligned parallel to the wavevector as this is the simplest case exhibiting both resonances. We have presented results for a capacitance corresponding to the nominal unbiased diode capacitance of 2.7 pF, as well as for the capacitance tuned to

1 pF. This capacitance shift is higher than what we expect to occur in the experiment due to nonlinear self-tuning, however, it clearly illustrates that a change in the loading capacitance changes the resonant response of the electric dipole moment. There is no visible difference between the two curves of the magnetic dipole moment *across the entire simulated frequency range*, again confirming that even in the case of very strong nonlinear or external tuning the magnetic response remains constant and linear.

In conclusion, we have suggested, designed, and analyzed a new type of nonlinear metamaterial with a dominant negative electric response. We have showed that we are able to introduce nonlinearity into the electric response making it tunable while leaving the magnetic response unchanged. We expect that our results would constitute the building blocks of a complete nonlinear negative index metamaterial containing both nonlinear or tunable electric and magnetic elements, which can be engineered independently.

¹V. Veselago, *Sov. Phys. Usp.* **10**, 509 (1968).

²D. Smith, W. Padilla, D. Vier, S. Nemat-Nasser, and S. Schultz, *Phys. Rev. Lett.* **84**, 4184 (2000).

³R. Liu, A. Degiron, J. J. Mock, and D. R. Smith, *Appl. Phys. Lett.* **90**, 263504 (2007).

⁴D. Schurig, J. J. Mock, and D. R. Smith, *Appl. Phys. Lett.* **88**, 041109 (2006).

⁵H.-T. Chen, W. J. Padilla, J. M. O. Zide, S. R. Bank, A. C. Gossard, A. J. Taylor, and R. D. Averitt, *Opt. Lett.* **32**, 1620 (2007).

⁶M. Gorkunov and M. Lapine, *Phys. Rev. B* **70**, 235109 (2004).

⁷J. Pendry, A. Holden, D. Robbins, and W. Stewart, *IEEE Trans. Microwave Theory Tech.* **47**, 2075 (1999).

⁸A. Zharov, I. Shadrivov, and Y. Kivshar, *Phys. Rev. Lett.* **91**, 037401 (2003).

⁹I. Gil, J. Garcia-Garcia, J. Bonache, F. Martin, M. Sorolla, and R. Marques, *Electron. Lett.* **40**, 1347 (2004).

¹⁰I. Shadrivov, S. Morrison, and Y. Kivshar, *Opt. Express* **14**, 9344 (2006).

¹¹D. A. Powell, I. V. Shadrivov, Y. S. Kivshar, and M. V. Gorkunov, *Appl. Phys. Lett.* **91**, 144107 (2007).

¹²I. V. Shadrivov, A. B. Kozyrev, D. W. van der Weide, and Y. S. Kivshar, *Opt. Express* **16**, 20266 (2008).

¹³I. V. Shadrivov, A. B. Kozyrev, D. W. van der Weide, and Y. S. Kivshar, *Appl. Phys. Lett.* **93**, 161903 (2008).

¹⁴For most orientations of the resonators relative to the incident wavevector, retardation effects will cause some phase shift in the fields across each element, thus complete cancellation of the dipole moment may not occur at the resonant frequency.

¹⁵Computer Simulation Technology, see: <http://www.cst.com>.

¹⁶C. R. Simovski and S. A. Tretyakov, *Phys. Rev. B* **75**, 195111 (2007).

¹⁷R. E. Raab and O. L. de Lange, *Multipole Theory in Electromagnetism* (Clarendon, Oxford, 2005).