

UDC 81'367.5

Original scientific paper

Received 12.06. 2002

Accepted for publication on 02.04. 2003

Paweł Rutkowski

Warsaw University

Poland

and

Universidad Autónoma de Madrid

Spain

Noun/pronoun asymmetries: Evidence in support of the DP hypothesis in Polish¹

The aim of this paper is to analyse the syntax of Polish nominal expressions in terms of what is known as the *DP hypothesis* (the idea that was discussed in Abney 1987). The fact that articles occupy the D position crosslinguistically is widely accepted. But many linguists have raised the question whether it is reasonable to assume the DP hypothesis for languages that do not have lexical articles. Polish is an articleless language. In this paper, I will argue that even Polish has the DP layer. Furthermore, I will show that it projects at least one more functional phrase between NP and DP. The evidence for the above claims will be based on certain DP-internal word order facts. I will account for them by pos-

¹ This paper was presented at the 10th *Postgraduate Linguistics Conference* held in Manchester in March 2001 and at the 7th *Doctorate Meeting in Linguistics* at the University Paris 7 in May 2002. Its slightly different version was published in the proceedings of the latter conference (Rutkowski 2002). I would like to thank Jan Fellerer, Ljiljana Progovac, the audiences in Manchester and Paris and two anonymous *Jezikoslovlje* referees for many helpful comments and suggestions.

tulating that, in the absence of lexical articles, other elements may move to the functional projections above NP and lexicalise them in overt syntax.

Keywords: the DP hypothesis, nouns, pronouns, functional projections, word order, N-to-D movement

1. Introduction

Following Abney (1987), it has been widely assumed in generative literature that nouns project up higher functional categories – D(eterminer)s, which head their own phrases (DPs – Determiner Phrases). There are restricted classes of items that have been considered to occupy the D node. Articles (such as *the* in English) are the most obvious instantiation of the position in question. Under the assumption that all languages share the same underlying phrase structure (cf., e.g., Kayne 1994), DPs should be projected both in languages that have articles and in those that do not. In this paper, I will consider an example of a language without lexical articles, namely Polish. Some researchers (e.g. Willim 2000) have argued that the lack of articles makes the DP hypothesis inapplicable to Polish. However, I will postulate that what appears to be a bare NP in Polish is actually headed by the D node, which often remains empty (at least in overt syntax) but may also be filled by certain elements from lower positions inside the nominal structure that move to it. The strongest evidence comes from DP-internal word order facts. In particular, my goal is to examine a number of noun/pronoun asymmetries. I will also attempt to show that DP is not the only functional projection in Polish nominal expressions. In order to account for certain phenomena related to case assignment in structures containing numerals and pronouns such as *coś* ‘something’, another functional phrase must be argued for.

2. Noun/pronoun asymmetries with respect to attributive adjectives

In Polish, attributive adjectives generally precede nouns (including proper names). This statement has to be understood as describing the unmarked order. Therefore, the opposite order (a noun followed by an adjective) should be considered ungrammatical unless the noun is emphasised phonologically or topicalised (which would lead to a marked reading).

Polish personal pronouns, unlike nouns, tend not to be modified by adjectives (this could be viewed as a crosslinguistic property of personal pronouns – therefore, Abney 1987 assumes that they usually remain “dangling” – i.e. they do not take any complements or specifiers). However, there are a few adjectives which, under certain reading, might be allowed as modifiers of pronouns. Interestingly enough, this class of adjectives seems to be present in other Slavic languages as well. Progovac (1998) shows the following data from Serbian/Croatian:

- (1) a. i [samu Mariju] to nervira
and alone Mary that irritates
‘that irritates even Mary’
- b. i [nju samu] to nervira
and her alone that irritates
‘that irritates even her’
- c. *i [samu nju] to nervira
and alone her that irritates

When adjectives such as *sama* above appear with personal pronouns, they are admitted only to the right of the pronominal head. Exactly the same phenomenon might be observed in Polish:

- (2) a. [sam Chomsky] czytał mój artykuł
alone Chomsky read my article
‘even Chomsky read my article’
- b. [on sam] czytał mój artykuł
he alone read my article
‘even he read my article’
- c. *[sam on] czytał mój artykuł
alone he read my article

The DP hypothesis proposed by Abney (1987) provides an elegant explanation for the above asymmetries. They could be accounted for by assuming that personal pronouns reside in the D node, whereas nouns occupy the N position (this idea stems from Postal 1969). The assumption that nouns and personal pronouns are not competing for the same syntactic slot seems to be supported by examples such as (3a-c):

- (3) a. we linguists like formalisation
b. my lingwiści lubimy formalizację (Polish)

- ‘we linguists like formalisation’
c. mi lingvisti volimo formalizaciju (Croatian)
‘we linguists like formalisation’

If we consider nominal constructions in the above examples to be mono-phrasal, their syntactic representation should be as follows:

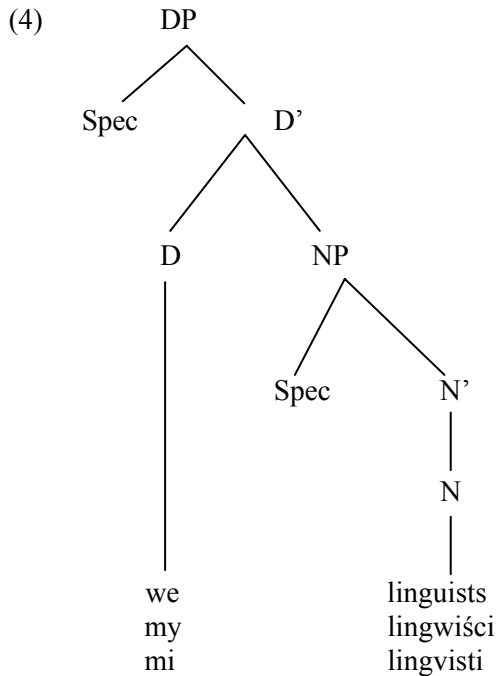

However, many linguists (e.g. Willim 2000) note that constructions such as *we linguists* might be considered appositive, i.e. parallel to structures like *Paul Jones, the student of linguistics*. They also point out that constructions such as *I linguist* or *he linguist* are generally ungrammatical, which suggests that the internal structure of expressions such as *we linguists* is more complex than what has been shown in (4) – cf. Panagioditis (1998). This means that the examples (3a-c) cannot be considered as evidence for the suggestion that personal pronouns and nouns are not in competitive distribution.

Researchers such as Cardinaletti (1993) claim that personal pronouns do not occupy the D position underlyingly. Instead, they are generated in N (just like regular nouns) and move to D in overt syntax for referential reasons. Progovic (1998) follows the above line of reasoning in her analysis of struc-

tures shown in (1). She argues that the order in (1b) results from raising the pronoun from an underlying position in N to D, crossing the adjective *sama*, which occupies a fixed syntactic position (adjectives are widely assumed to be some kind of Spec-based modifiers). Drawing on the work by Progovac (1998), we can describe the Polish data in (2) in a similar way. The derivation in question (N-to-D movement of the pronoun) is illustrated below:

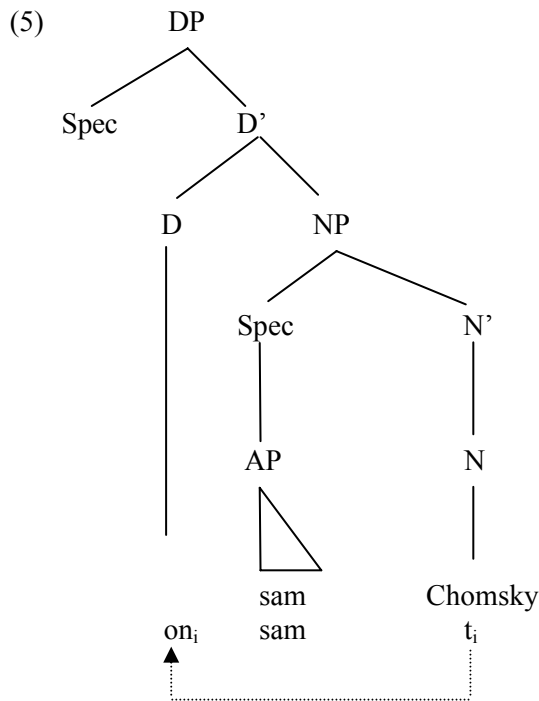

Progovac (1998) suggests that the obligatory movement of a personal pronoun (often referred to as the *N-to-D raising*) might be driven by the Principle of Greed (cf. Chomsky 1995), which makes pronoun move in order to check its referential features.

3. Noun/pronoun asymmetries with respect to the quantifier *wszysty* 'all'

The pattern described in the previous section does not seem to be an isolated idiosyncratic phenomenon in Polish. It can be traced in another nominal construction, namely in DPs modified by the quantifier *wszysty* 'all.'

- (6) a. [wszyscy lingwiści] czytali mój artykuł
all linguists read my article
'all linguists read my article'
- b. [wy wszyscy] czytaliście mój artykuł
you all read my article
'all of you read my article'
- c. *[wszyscy wy] czytaliście mój artykuł
all you read my article

As shown above, the quantifier *wszyscy* 'all' always follows personal pronouns. Giusti and Leko (1995) notice the same regularity in other languages. They account for it by assuming that the pronoun rises to the specifier of the phrase headed by the quantifier. The diagram in (7) illustrates Giusti and Leko's (1995) approach: the complement of the quantifier (i.e. the pronoun) can optionally rise in Italian and must rise in French and English:

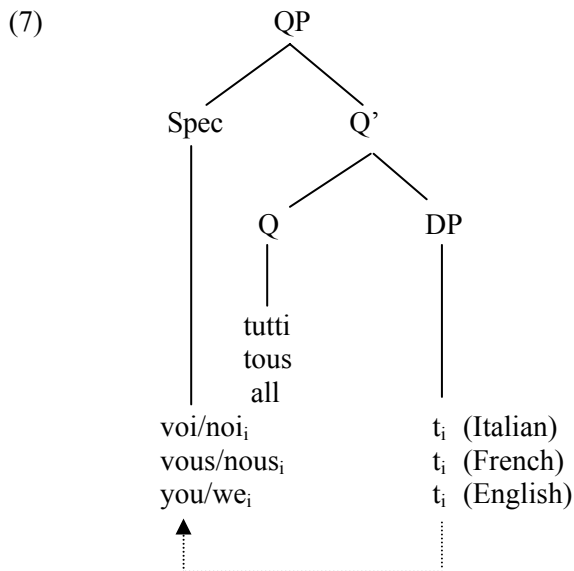

Giusti and Leko (1995) admit that they cannot give any plausible reason for the movement of the pronominal DP (as opposed to regular DPs, which do not rise). I would like to propose an analysis that describes the data in (6b) and (7) without postulating an extra phrase above DP. I assume that quantifiers such as *wszyscy* 'all' in Polish are base generated in a specifier position inside the DP. This assumption is based on the fact that, from a morphosyn-

tactic point of view, quantifiers such as *wszyscy* ‘all’ behave like regular adjectives in Polish – they always agree in case, gender and number with the following noun (which suggests a spec-head relation). This means that DP is always the highest nominal projection. Thanks to the above assumption we can analyse the structures containing the quantifier *wszyscy* ‘all’ in a way parallel to the analysis of structures with adjectives proposed in the previous section. Once again, the asymmetrical word order (shown in (6)) can be interpreted as following from the independently motivated N-to-D raising of pronouns and no extra movement operation has to be postulated.

4. Noun/pronoun asymmetries with respect to numerals

For independent reasons, it has been argued that Polish numerals are functional elements, occupying a functional head projected above NP (see Rutkowski 2001a). What is notable about the syntax of numeral quantifiers is that they normally precede nouns, but follow pronouns:

- (8) a. [siedmiu policjantów] czytało ten artykuł
 seven policemen:GEN read this article
 ‘seven policemen read this article’
- b. [ich siedmiu] czytało ten artykuł
 they:GEN seven read this article
 ‘seven of them read this article’
- c. *[siedmiu ich] czytało ten artykuł
 seven they:GEN read this article

The above noun/pronoun asymmetry is parallel to the ones shown in (2) and (6), but it differs as far as case assignment is concerned. Polish adjectives and quantifiers such as *wszyscy* ‘all’ always manifest agreement with the head noun with respect to all features (including case). On the other hand, in certain contexts (when the whole DP appears in the subject or the accusative object position), numerals make the noun assume a case form which it would not otherwise take (the so-called Genitive of Quantification GEN(Q) – cf., e.g., Franks 1995). Rutkowski (2001a) assumes that the numeral resides in the head Q (projected in the region between NP and DP) and assigns genitive to its complement (NP). Since the pronoun in (8b) is also assigned genitive, it must be base generated inside NP (and raised to D after GEN(Q) assignment).

(9)

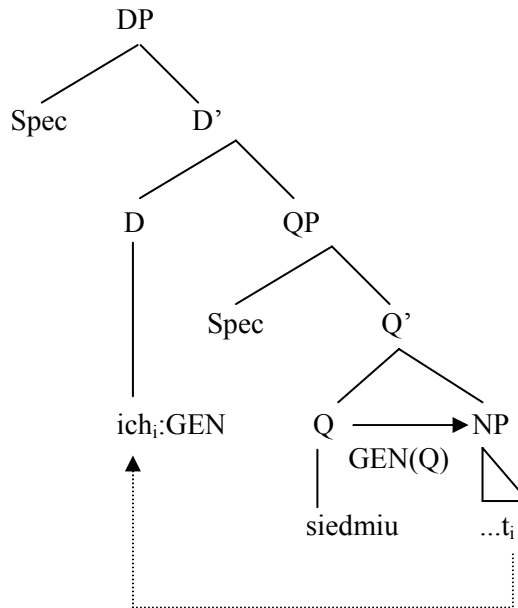

This analysis crucially depends on the presence of the N-to-D movement of pronouns. Without postulating such a movement, the fact that the element that precedes the numeral has a genitive marking would not be explainable. Therefore, I claim that the syntax of numeral constructions provides another argument for a DP analysis of Polish nominal structures. Similarly to the other expressions containing pronouns (discussed in the previous sections), numeral constructions can be analysed in an elegant and coherent way only if we assume that the D node, being the target of the N-to-D raising, is syntactically active in Polish.

5. Noun/pronoun asymmetries in the construction *coś ciekawego* ‘something interesting’

The final argument in support of the claim that the DP hypothesis holds for Polish is indirect. However, it is closely linked to the previous discussion. If we accept that pronouns are base generated inside NP and then rise to functional projections above it, it seems reasonable to assume that also in examples like (10a) the attributive adjective appears at the right periphery of the nominal construction as a result of raising of the pronoun across it.

- (10) a. *lingwista zobaczył [coś ciekawego]*
 linguist saw something interesting:GEN
 ‘a linguist saw something interesting’

- b. lingwista zobaczył [ciekawą nielingwistkę]
 linguist saw interesting:ACC non-linguist
 ‘a linguist saw an interesting non-linguist’
- c. *lingwista zobaczył [ciekawego coś]
 linguist saw interesting:GEN something

The pronoun *coś* ‘something’ assigns genitive in Polish (see a detailed discussion in Rutkowski 2001b). Note that some native speakers of Polish accept the pronoun *coś* at the right periphery of the phrase but only if the case marking of the preceding adjective is nominative:

- (11) % ciekawe coś
 interesting:NOM something

This suggests that the pronoun assigns the genitive only after moving to a slot above the adjective. If the movement does not take place, the genitive cannot be assigned.

Kishimoto (2000) argues that indefinite pronouns in English (such as *something*, *anything*, *everybody*) consist of a determiner (e.g. *some*) and a light noun (*thing*, *body* etc.). The semantically light nouns are susceptible to overt head raising (in a way comparable to overt V-to-T raising of the light verbs *have* and *be*). It is illustrated in (12).

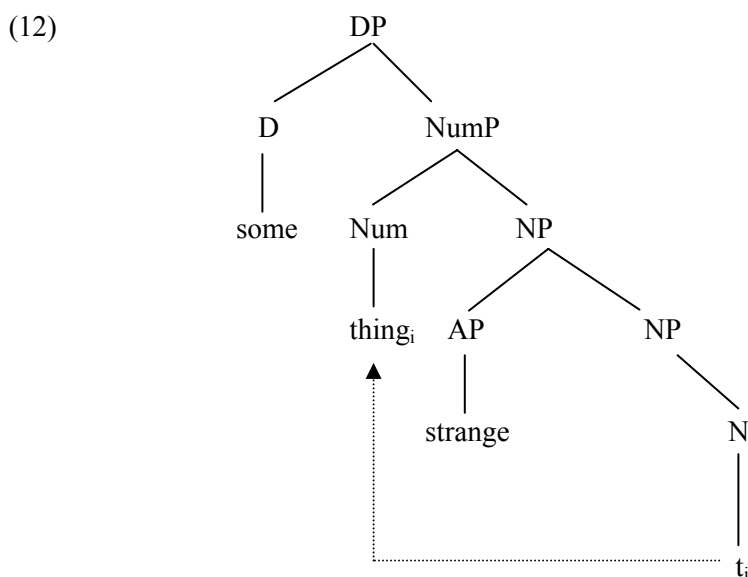

Similarly, Rutkowski (2001b) proposes that the Polish pronoun (“light noun”) *coś* ‘something’ moves from N to a functional phrase above NP. It targets a position comparable to what Rutkowski 2001a refers to as QP and what Ritter 1992 and Kishimoto 2000 label NumP. The word *coś* ‘something’ and numerals must occupy the same syntactic slot because they assign genitive in the same contexts (namely, the subject and accusative object positions – cf. Rutkowski and Szczegot 2001). Whatever the label of that slot, Kishimoto (2000), Rutkowski (2001b) and Rutkowski and Szczegot (2001) assume that the indefinite pronoun must land in a functional projection above NP. This analysis requires that both English and Polish nouns project functional phrases and, indirectly, supports the DP approach to Polish nominals.

6. Concluding remarks

On the basis of the above observations, I suggest that, even in Polish, there are functional categories associated with the noun. Since there are no lexical articles in Polish, the presence of D is manifested otherwise. The D position must be syntactically active since it is targeted by overt N-to-D raising in certain constructions with numerals, quantifiers and attributive adjectives. Moreover, there is evidence for another functional projection – located between DP and NP. The head of this phrase hosts numerals and has to be considered the target for the raising of elements such as the pronoun *coś* ‘something.’

Author’s address:

ul. Warszawska 55a m.7
15-062 Białystok
Poland
rutkowski@zigzag.pl

References

- Abney, Steven P. (1987). The English noun phrase in its sentential aspect. PhD dissertation. MIT.
- Alexiadou, Artemis, Chris Wilder, eds. (1998). *Possessors, Predicates and Movement in the Determiner Phrase*. Amsterdam, Philadelphia: John Benjamins Publishing Company.
- Cardinaletti, Anna (1993). On the internal structure of pronominal DPs. *University of Venice Working Papers in Linguistics* 3.2: 1-20.
- Chomsky, Noam (1995). *The Minimalist Program*. Cambridge, Mass.: MIT Press.

- Franks, Steven (1995). *Parameters of Slavic Morphosyntax*. New York, Oxford: Oxford University Press.
- Giusti, Giuliana, Nedžad Leko (1995). On the syntax of quantity expressions in Bosnian. *University of Venice Working Papers in Linguistics* 1.2: 23-47.
- Kayne, Richard (1994). *The Antisymmetry of Syntax*. Cambridge, Mass.: MIT Press.
- Kishimoto, Hideki (2000). Indefinite pronouns and overt N-Raising. *Linguistic Inquiry* 31: 557-566.
- Panagiotidis, Phoevos (1998). The internal structure of English pronouns. In: Lambropoulou, S. ed. *The 12th International Symposium on Theoretical and Applied Linguistics: Proceedings*. Vol. 1, 84-94. Thessaloniki: Aristotle University of Thessaloniki.
- Postal, Paul (1969). On so-called "pronouns" in English. In: Reibel, D., S. Schane, eds. *Modern studies in English*, 201-224. Englewood Cliffs, NJ: Prentice-Hall.
- Progovac, Ljiljana (1998). Determiner phrase in a language without determiners. *Journal of Linguistics* 34: 165-179.
- Ritter, Elizabeth (1992). Cross-linguistic evidence for Number Phrase. *Canadian Journal of Linguistics* 37: 197-218.
- Rutkowski, Paweł (2001a). Numeral phrases in Polish and Estonian. In: Holmer, A., J.-O. Svantesson, Å. Viberg, eds. *Proceedings of the 18th Scandinavian Conference of Linguistics*. Vol. 2. Travaux de l'Institut de Linguistique de Lund 39.2, 181-190. Lund: Lund University Press.
- Rutkowski, Paweł (2001b). Something strange in Slavic, Lithuanian and German: About the inherent vs. structural case distinction. In: Aim, E., K. Gerdes, H.-Y. Yoo, eds. *6e rencontres de l'atelier des doctorantes en linguistique. Actes*, 137-142. Paris: Université Paris 7.
- Rutkowski, Paweł (2002). Noun/pronoun asymmetries: evidence in support of the DP hypothesis in Polish. In: Afuta, P., A. El Ghali, F. Toussenet, eds. *ADL'2002*, 91-96. Paris: Université Paris 7, Ecole Doctorale de Sc. du Langage.
- Rutkowski, Paweł, Kamil Szczegot (2001). On the syntax of functional elements in Polish: Numerals, pronouns and expressions indicating approximation. In: Przepiórkowski, A., P. Bański, eds. *Generative Linguistics in Poland: Syntax and Morphosyntax*, 187-196. Warsaw: IPI PAN.
- Willim, Ewa (2000). On the grammar of Polish nominals. In: Martin, R., D. Michaels, J. Uriagereka, eds. *Step by Step: Essays on Minimalist Syntax in Honor of Howard Lasnik*. Cambridge, Mass.: MIT Press.

ASIMETRIJE IZMEĐU IMENICA I ZAMJENICA:

U PRILOG HIPOTEZE O DETERMINATORSKOM IZRAZU (DP) U POLJSKOME

Cilj je rada analizirati sintaksu poljskih imeničkih izraza u svjetlu pojave poznate kao DP hipoteza (ideja o kojoj se raspravlja Abney 1987). Opće je prihvaćena činjenica da u mnoštvu jezika članovi zauzimaju poziciju determinatora (D poziciju), no mnogi su lingvisti postavili pitanje je li razumno takvo što pretpostaviti i za jezike koji nemaju leksičke članove. Poljski je među jezicima koji nemaju članove. U prilogu se tvrdi da je nivo s determinatorskim izrazom prisutan i u poljskome. Štoviše, tvrdi se da se između imenskog i determinatorskog izraza projicira barem još jedan funkcionalni iz-

raz. Potvrda za tu tvrdnju nalazi se u određenim činjenicama glede poretka riječi unutar determinatorskog izraza. Te se činjenice objašnjavaju pretpostavkom da se u nedostatku leksičkih članova drugi elementi mogu pomicati u funkcionalne projekcije iznad imenskog izraza te eksplicitno leksikalizirati u njihovoj sintaksi.

Ključne riječi: hipoteza o determinatorskom izrazu, imenice, zamjenice, funkcionalne projekcije, red riječi, pomicanje imenica prema determinatoru