

NOVEL COMPACT MICROSTRIP ULTRA-WIDEBAND FILTER UTILIZING SHORT-CIRCUITED STUBS WITH LESS VIAS

M. S. Razalli, A. Ismail, and M. A. Mahdi [†]

Department of Computer and Communication Systems Engineering
Faculty of Engineering
Universiti Putra Malaysia
43400 UPM Serdang, Selangor, Malaysia

M. N. Hamidon

Department of Electrical and Electronic Engineering
Faculty of Engineering
Universiti Putra Malaysia
43400 UPM Serdang, Selangor, Malaysia

Abstract—We present here a new pattern with compact size of Ultra Wideband (UWB) microwave filter. The filter is based on quarter-wave length short-circuited stubs model. We introduced here a new schematic model by extracting all parasitic elements such as T-junction and discontinuity in our new pattern of UWB filter. This new filter has minimal number of vias and improved frequency bandwidth, insertion loss and return loss. It is fabricated on RT Duroid 5880 with 0.508 mm of substrate thickness. The final dimension is measured as 21 mm × 14 mm. It is not only compact, but also delivers excellent scattering parameters with magnitude of insertion loss, $|S_{21}|$ lower than 0.85 dB and return loss better than -11.6 dB. The fractional bandwidth is 109% from 3.06 GHz to 10.43 GHz. In the pass band, the measured group delay varies in between 0.47 ns to 0.32 ns, showing stability with minimum variation of only 0.15 ns.

[†] The first author is also with School of Computer and Communication Engineering, Universiti Malaysia Perlis, P. O. Box 77, Pejabat Pos Besar 01007 Kangar, Perlis, Malaysia

1. INTRODUCTION

Recently, Ultra Wideband (UWB) technology has become a major interest to researchers and scientists since the technology itself promises ultra high speed communication. This is based on its ultra narrow signal in the form of pulses ranging from 1 ns to 0.1 ns. Unlike an ordinary radio transmission which uses carrier frequency, UWB is a carrier-less with a wide spread spectrum. The implementation of the UWB technology originally came from military radio to avoid detection from ones enemies. It is now legally open to non-military users around the world. Federal Communication and Commission (FCC) has offered a license band of UWB with rules such as bandwidth must be greater than 500 MHz and frequency ranges are permitted from 3.1 GHz to 10.6 GHz with a low power transmission at -41 dBm [1]. Several experiments, methods and techniques had been studied purposely to expand the bandwidth of bandpass filters in the past decade. Some of them were employing methods from dielectric filled waveguides, trisection substrate-integrated waveguide, resonators, coplanar waveguide, quarter-wavelength short-circuited stubs and/or open-circuited stubs, and hairpin [2–18].

A research in [2], presents the bandpass filter functioned by serial shunted line configuration. The filter consists of short-circuited stubs and two sections of open circuited stubs. They are connected by transmission lines creating larger size of microstrip. The operating frequency range from 2.0 GHz to 6 GHz is reported, which does not fully utilize the whole range of approved FCC frequency spectrums. Another filter presented in [3] is developed by using shielded multi-layer structure. The parasitic elements have been extracted to improve the S -parameters, thus resulting in fractional bandwidth (FBW) of 87.4%, but still below than 100% that we want to achieve in our design.

There are two types of filters employing parallel coupled line sections in their multiple-mode resonator such as [4] and [5]. A filter in [6] is cascaded of shunt short-circuited stubs and a parallel coupled step-impedance resonator. Reference [7] presented on interdigital-coupled line stepped impedance open stubs. Filters reported from [4] to [7] are achieving the whole pass band permitted by FCC. However, their coupled line sections width and gap are so tight from 0.1 mm to 0.05 mm. Practically, these gap sizes which is below than 0.1 mm are very critical during fabrication process in which high accuracy is essentially needed. Another filter reported in [8] is using aperture-backed interdigital coupled lines and stub-loaded folded stepped-impedance resonator. This filter however has a tight coupling of 0.2 mm in its interdigital coupled line structures. Filter reported

in [9], is an advantageous feature in strip conductor and ground planes due to easy linked together to make up a short-circuited end. However, the coupled spacing (d) is optimized at 2 mil (0.0508 mm), which is critical and requires high precision fabrication area. Filter in [10], implements back-to-back microstrip CPW. It has a maximum magnitude of insertion loss 1.83 dB between 7.2 GHz to 9.6 GHz. However, the filter does not fully utilize the approved FCC bandwidth. Its bandwidth is only covered from 3.4 GHz to 9.6 GHz which leaves 1 GHz of un-used frequency band.

A hairpin filter presented in [11] is a dual band filter which is purposely designed and developed for direct sequence UWB for wireless personal area network (WPAN). Due to the loading effect of hairpin line filter for high pass band (6.2–9.7 GHz), resulting in poor return loss in the lower pass band (3.1–4.9 GHz). Furthermore, the total size of the filter which is 28.85 mm \times 13.2 mm creates a large space area for the fabrication on microstrip. Another filter in [12] implements coupled straight and bent resonator. The design is a multiple-stopband filter by suppressing the interference in UWB applications. The filter implements five short-circuited vias and proposes a new principle by implementing two lumped capacitors as tuning element to control the bandwidth. Due to poor soldering on the via holes and lumped capacitors has contributed to high insertion loss at high frequencies.

Filter presented in [13] is a narrow-bandpass filter with 3% fractional bandwidth and excellent return loss at -20 dB. As reported in [14] is a designed method to optimize an open-end effect in parallel-coupled microstrip bandpass filters which has delivered higher efficiency and accuracy. Two types of coupled resonators as reported in [15, 16] are bandpass filters. In [15], it performs UWB frequency response from 1 GHz to 4.6 GHz with 128% of fractional bandwidth and [16] is a dual mode resonator which performs a narrow-band frequency response. A compact bandpass filter utilizing dielectric filled waveguides is presented in [17]. It uses inductive diaphragms in a rectangular waveguide with dielectric filled between them. The -3 dB cut off frequencies are from 9.5 GHz to 10.7 GHz and the designed filter has 57% compactness compared to the conventional air-filled filter. A miniature planar UWB filter with circular slots in ground is presented in [18]. It has slight ripple of insertion loss throughout the pass band from 3.14 GHz to 8.28 GHz with a compact size 15 \times 12.4 mm².

In this paper, a new pattern and compact size of UWB microwave bandpass filter is to be proposed, called as “Butterfly”. Theories and techniques are to be described to extract the parasitic elements in our new model filter. The filter has demonstrates better S -parameters and group delay performance as well as compact fabrication size.

2. THEORY AND SIMULATION

The UWB “Butterfly” filter is generated from five poles quarter-wavelength short-circuited stubs as reported in our previous work [19]. In [19], the five poles quarter-wavelength short-circuited stubs successfully delivers the UWB frequency response within the range from 2.7 GHz to 9.83 GHz with 6.26 GHz midband frequency. The FBW is greater than 100% and magnitude of insertion loss is 1.27 dB with return loss of better than -7.8 dB across the band. Figure 1 shows the five poles quarter-wavelength short-circuited stubs model. In [19], the stubs are individually grounded, which means there is a grounded via on the end of each of the five stubs.

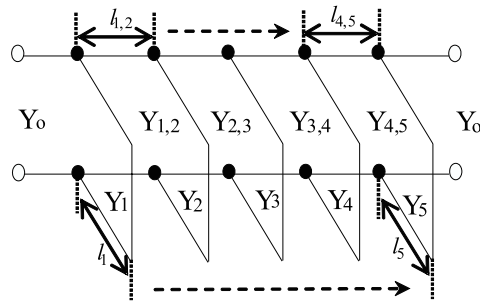

Figure 1. Quarter-wave length short-circuited stubs model.

Based on our previous research work in [19], it shows that bandpass filter utilizing short-circuited stubs (using via) has a great potential for bandwidth expansion. However, filter utilizing short-circuited stubs i.e., using via as a short-circuited element, has the potential signal quality degradation due to parasitic effects such as inductive, capacitive and resistive that exist in its discontinuity parameters. To reduce the losses, quantity of vias must be reduced to maintain the optimum S -parameters performance as well as achieving miniaturization of the filter itself. To perform the “Butterfly” shape UWB filter, five stubs are bent and re-arranged to form shared vias. The “Butterfly” shape filter is shown in Figure 2. The pattern presented in this paper, shown in Figure 2 consists of two different pair of stubs sharing two vias. Stubs 1 and 2 are sharing a via while stubs 4 and 5 are grounded using another separate via. Stub 3 is short-circuited to its own via.

Having this improved configuration, the number of via is reduced from five to three and hence decreases the total area of the filter. To share via, each stub and transmission line must be bent properly to

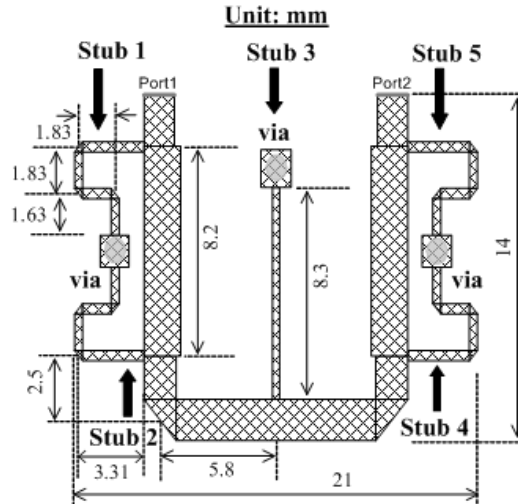

Figure 2. “Butterfly” shape UWB filter.

achieve the best scattering results. Therefore, the bending property of microstrip is important in our proposed UWB filter design. There were several researches and studies done on microstrip bending i.e., discontinuity properties of microstrip [20–25]. The studies were concerned on capacitance and inductance parasitic effects in microstrip circuit. As reported in [20–23], the discontinuities in microstrip circuit could be modeled as a T-network. The capacitive and inductive parameter effects could be varied and compensated by cutting inner, outer or 45° mitered at the corner of a microstrip line.

One good example in [24] was a verification of new parameter in ring resonator with improved S -parameters. The ring resonator was 45° mitered bend and simulated to optimize its resonant frequency. As shown in Figure 3, there are four types of bending (discontinuity) properties, where: (a) 90° bend and its equivalent circuit, (b) 45° mitered, (c) inner cutoff and (d) outer cutoff. The compensation may be achieved by implementing either one of these configuration in our “Butterfly” UWB filter. Reported in [22] and [23], based on the equivalent circuit in Figure 3(e), for inner cutoff (Figure 3(c)), inductance is increased due to the increases of current path as well as inductive length (ΔL) while capacitance (ΔC) is reduced. On the other hand, when the outer cutoff (Figure 3(d)) and 45° mitered (Figure 3(b)) are applied, the effects are similar for both, where capacitance (ΔC) is removed and inductance or (ΔL) is not increased.

As reported in [21], approximation for 90° bend mathematic

derivations are expressed by:

$$\frac{C}{W}(\text{pF/m}) = \frac{(14\varepsilon_r + 12.5)W/h - (1.83\varepsilon_r - 2.25)}{\sqrt{W/h}} + \frac{0.02\varepsilon_r}{W/h}, \text{ for } W/h < 1 \quad (1)$$

$$\frac{C}{W}(\text{pF/m}) = (9.5\varepsilon_r + 1.25)W/h + 5.2\varepsilon_r + 7.0, \text{ for } W/h \geq 1 \quad (2)$$

$$\frac{L}{h}(\text{nH/m}) = 100 \left[4\sqrt{\frac{W}{h}} - 4.21 \right] \quad (3)$$

while for the 45° mitered bend derivations are as follows [22]:

$$C = 0.001h \left[(3.39\varepsilon_r + 0.62) \left(\frac{W}{h} \right)^2 + 7.6\varepsilon_r + 3.8 \left(\frac{W}{h} \right) \right] \text{ pF} \quad (4)$$

$$L = 0.22h \left[1 - 1.35 \exp \left[-0.18 \left(\frac{W}{h} \right)^{1.39} \right] \right] \text{ nH} \quad (5)$$

where substrate thickness (h) and width (W) are in millimeters.

In the “Butterfly” model, stubs are bent so that they are able to share vias, therefore there are 14 bending sections involved in the circuit layout. Such configuration has created a combination of 14 equivalent circuits of Figure 3(e), consisting also T -junctions

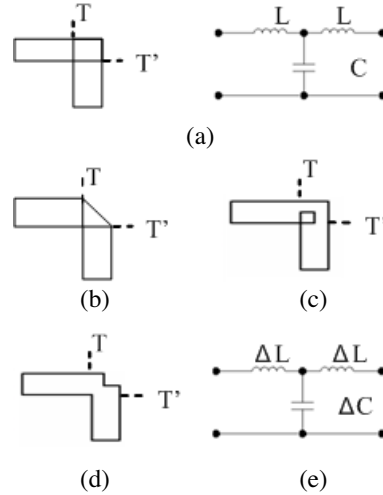

Figure 3. Various type of microstrip bending techniques, (a) 90° bend and its equivalent circuit, (b) 45° mitered, (c) inner cutoff, (d) outer cutoff and (e) their equivalent circuit.

in between stubs and connecting $50\ \Omega$ transmission lines. Thus, a complete “Butterfly” shape UWB filter equivalent circuit is produced as shown in Figure 4. The filter is symmetrical, thus all parasitic elements can be extracted from only one side of the equivalent circuit. Inductance (L) and capacitance (C) are the parasitic elements (bending circuit), capacitance jBT is the T -Junction parasitic element between stub and connecting transmission line whereas l and w are line and width of stub, connecting transmission line and feeder. Based on Equations (1) to (5), the length and width are summarized in Table 1, with respect to Figure 4.

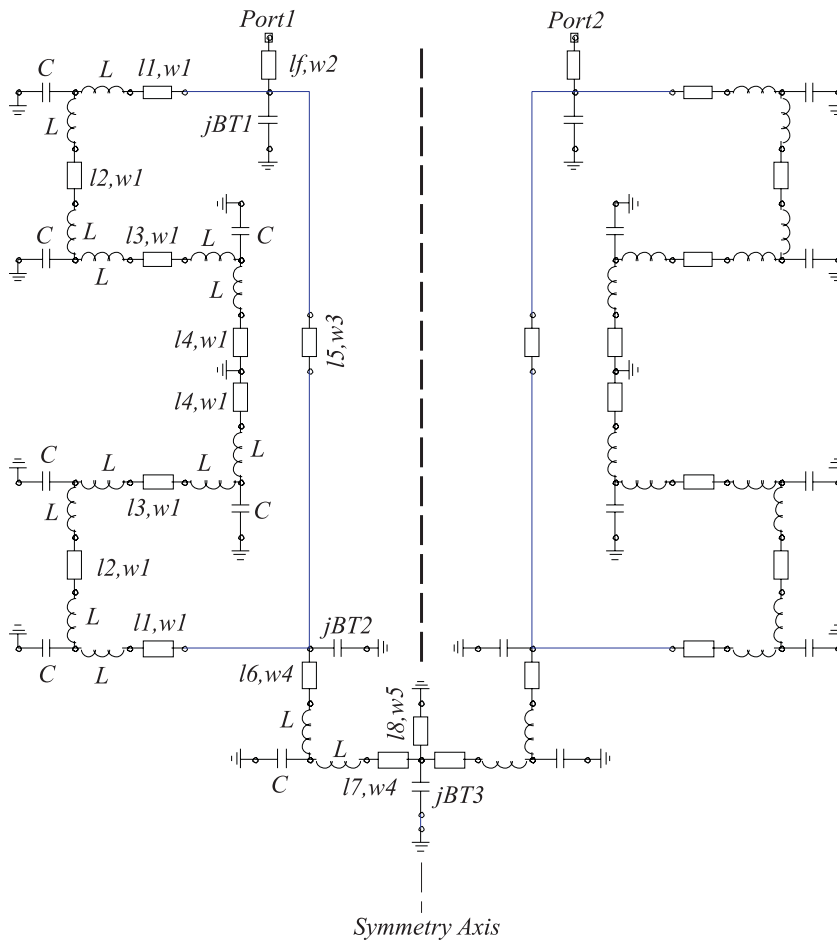

Figure 4. Equivalent circuit for “Butterfly” shape UWB filter.

Since there are four types of bending that are of interest as shown in Figure 3, the comparison between the four types are being made using an electromagnetic simulator CST Microwave Studio [26]. The simulations are essential to be performed in order to analyze which bending type is the most suitable to be used for the “Butterfly” shape filter. Figure 5 shows the simulated frequency responses with four types of different bending techniques applied in the UWB filter.

Table 1. Dimension of “Butterfly” shape UWB filter with reference to the equivalent circuit (Figure 4) and layout (Figure 2).

Length (mm)	Width (mm)	Items for
$M = 3.31$	$w1 = 0.4$	Stubs 1 and 2
$l2 = 1.83$		
$l3 = 1.83$		
$l4 = 1.83$		
$l8 = 8.3$	$w5 = 0.4$	Stub 3
$lf = 5$	$w2 = 1.52$	50 Ω Feeder (Port 1 and Port 2)
$l5 = 8.2$	$w3 = 1.8$	Transmission line between stubs 1 and 2
$l6 = 2.5$	$w4 = 1.6$	Transmission line between stubs 2 and 3
$l7 = 5.8$		

Table 2. Summary of insertion loss and return loss for Figure 5.

Bending Type	Frequency rang (dB)		Midband frequency (GHz)	FBW (%)	Max. Insertion loss, S_{21} in passband (dB)	Max. Return loss, S_{11} in passband (dB)
	Start Band	Stop Band				
45° Mitered	2.95	10.47	6.71	112	0.42	-15.60
90°	2.85	10.40	6.63	113	0.90	-9.06
Outer cut off	2.88	10.40	6.64	113	0.50	-13.00
Inner cut off	2.78	9.44	6.11	109	1.16	-1.34

From Figure 5(a), insertion loss for outer 90° bend and 45° mitered does slightly vary between each other. It is clear that the inner cutoff technique delivers poorest bandwidth compared to the other three techniques. The analysis has exhibits excellent frequency bandwidth of 2.95 GHz to 10.47 GHz for 45° mitered technique. Figure 5(b) shows clearly the inner cutoff and 90° bend deliver poor return loss in the passband. Their maximum peak return loss is worse than -10 dB. In contrast, the outer cutoff and 45° mitered deliver acceptable return loss in the passband. The outer cutoff has a maximum peak greater than -13 dB especially at 9.35 GHz. Meanwhile the 45° mitered delivers an excellent return loss in the pass band which is below than -15.6 dB. The scattering parameters simulation in Figure 5 can be summarized as tabulated in Table 2.

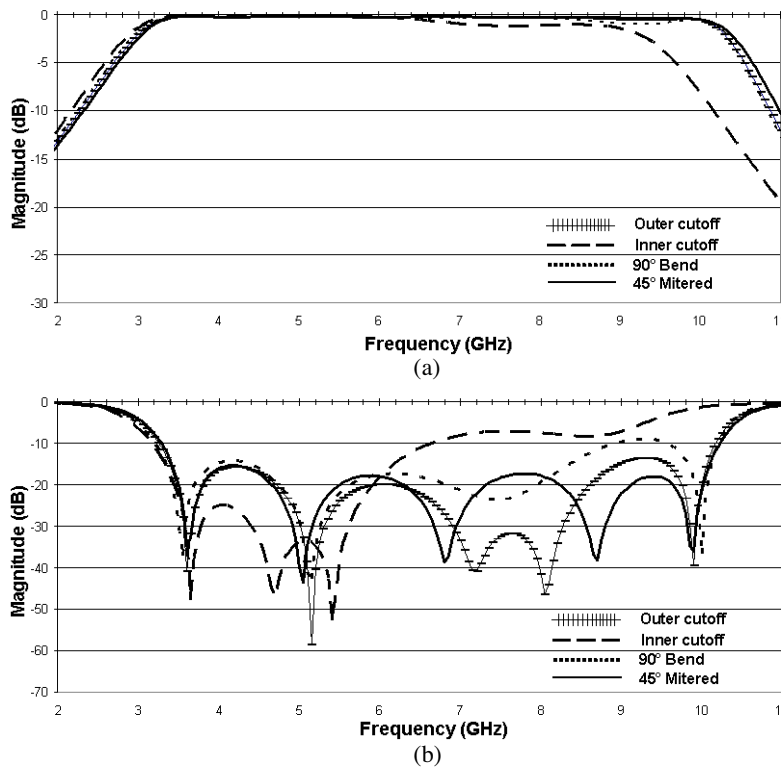

Figure 5. Simulated frequency response of “Butterfly” shape microstrip filter with four different types of bending, (a) insertion loss (S_{21}) and (b) return loss (S_{11}).

From the simulated scattering parameters in Figure 5 and summary in Table 2, it is concluded that 45° mitered is the best to be implemented in the filter design, as earlier shown in Figure 2. The overall dimension of “Butterfly” shape filter is $21\text{ mm} \times 14\text{ mm}$.

3. FABRICATION AND MEASUREMENT

The filter is realized by using standard photolithography process on R/T Duroid 5880 with relative permittivity 2.2, 0.508 mm of substrate thickness, $35\text{ }\mu\text{m}$ of copper thickness and substrate loss of $\tan\delta = 0.0009$. The fabricated prototype of our UWB filter is shown in Figure 6.

As shown in Figure 6, two $50\text{ }\Omega$ transmission lines are extended to accommodate the SMA connectors to connect to the Vector Network Analyzer (VNA) for measurement. Three vias on the prototype circuit are soldered directly to the ground copper layer.

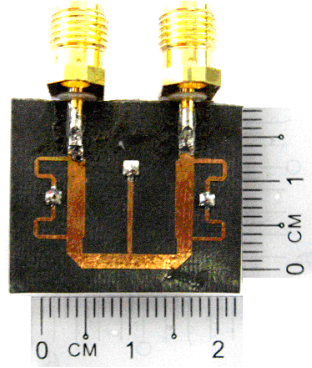

Figure 6. Compact “Butterfly” shape prototype.

The prototype in Figure 6 is measured by using Agilent E8362B PNA Network Analyzer to obtain its scattering parameters. Figure 7 shows the simulated and measured insertion loss (S_{21}) and return loss (S_{11}). The simulated and measured group delay is shown in Figure 8.

As shown in Figure 7(a), the measured insertion loss (S_{21}) agrees well with the simulated result. The measured -3 dB cut off frequency bandwidth is obtained from 3.06 GHz to 10.43 GHz giving a fractional bandwidth (FBW) of 1.09 or 109%. Excellent measured magnitude of insertion loss, $|S_{21}|$ is better than 0.85 dB across the passband. At the midband frequency of 6.745 GHz, the measured magnitude of insertion loss, $|S_{21}|$ is minimum at 0.4 dB.

Good measurement of return loss (S_{11}) is also obtained across the passband as shown in Figure 7(b). Maximum return loss of -11.6 dB is at 9.47 GHz. At midband frequency, excellent measured return loss

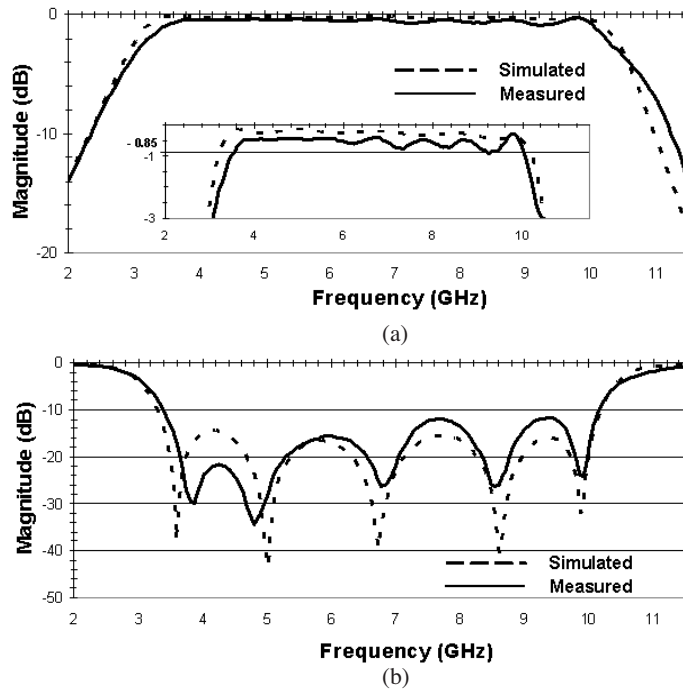

Figure 7. Simulated and measured responses of “Butterfly” UWB filter, (a) insertion loss (S_{21}) and (b) return loss (S_{11}).

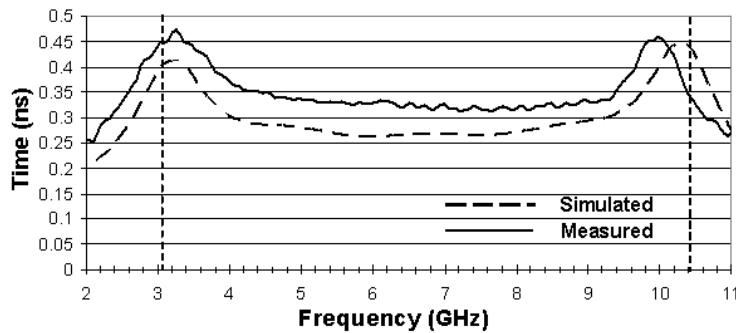

Figure 8. Simulated and measured group delay for “Butterfly” shape UWB filter.

(S_{11}) of -26.36 dB is achieved. Referring to Figure 8, at midband frequency, the measured group delay is 0.32 ns while in the passband; it varies between 0.47 ns to 0.32 ns giving an excellent maximum variation of only 0.15 ns. The measured S -parameters and group delay have manifest that this filter has an excellent performance and stable across the passband. From the measured results, most of the losses are contributed mainly by the fabrication inaccuracies of the prototype itself, mismatch at the connectors and material losses.

4. CONCLUSION

A compact, low loss UWB microstrip filter has been designed and developed consisting of “Butterfly” shape quarter-wavelength short-circuited stubs and connecting transmission lines, utilizing 45° mitered bend, with less number of vias compared to quarter-wave length short-circuited stubs filter reported in [19]. The new pattern delivers better S -parameters and group delay than its previous model [19], with a compact size of $21\text{ mm} \times 14\text{ mm}$, giving 30% size reduction. Equivalent circuit for the new filter has been extracted nicely.

To optimize the “Butterfly” shape and S -parameters before fabrication, four types of discontinuities associates in the prototype have been simulated. The technique of 45° mitered bend is implemented since it shows excellent simulated S -parameters. This new model prototype consumes 3 vias as short-circuited elements which exhibit a small scale development size and hence reduce the total development cost of the filter itself. The measured S -parameters and group delay have proved that the new filter has excellent characteristics and it is suitable to be fitted in radar and high speed wireless radio application systems.

REFERENCES

1. FCC, “Revision of Part 15 of the commission’s rules regarding Ultra-Wide-Band transmission system,” *Tech. Rep., ET-Docket*, 98–153, 2002.
2. Tsai, L. C. and C. W. Hsue, “Dual-band bandpass filters using equal-length coupled-serial-shunted lines and Z-transform technique,” *IEEE Transactions on Microwave Theory and Techniques*, Vol. 52, No. 4, 1111–1117, April 2004.
3. Tanaka, A. and Y. Horii, “A compact multilayered bandpass filter with transmission zeroes for UWB applications,” *IEEE Proceeding of Asia-Pacific Microwave Conference*, Vol. 1, 3–5, December 2005.

4. Zhu, L., S. Sun, and W. Menzel, "Ultra-wideband (UWB) bandpass filters using multiple-mode resonator," *IEEE Microwave Wireless Component Letters*, Vol. 15, No. 11, 796–798, November 2005.
5. Wong, S. W. and L. Zhu, "Implementation of compact UWB bandpass filter with a notch-band," *IEEE Microwave Wireless Component Letters*, Vol. 18, No. 1, 10–12, January 2008.
6. Chen, C. P., Z. Ma, N. Nagaoka, and T. Anada, "Novel compact Ultra-Wideband bandpass filter employing short-circuited stubs with coupled stepped impedance resonator," *IEEE Proceeding of Asia-Pacific Microwave Conference*, 1–4, December 2007.
7. Singh, P. K., S. Basu, and Y. H. Wang, "Planar ultra-wideband bandpass filter using edge couple microstrip lines and stepped impedance open stub," *Microwave Wireless Component Letters*, Vol. 17, No. 9, 649–651, September 2007.
8. Chu, Q. X. and S. T. Li, "Compact UWB bandpass filter with improved upper-stopband performance," *Electronic Letters*, Vol. 44, No. 12, 742–743, June 2008.
9. Gao, J., W. Menzel, and F. Bögelsack, "Short-circuited CPW multiple-mode resonator for ultra-wideband (UWB) bandpass filter," *Microwave Wireless Component Letters*, Vol. 16, No. 3, 104–106, March 2006.
10. Hu, H. L., X. D. Huang, and C. H. Cheng, "Ultra-wideband bandpass filter using CPW-to-microstrip coupling structure," *Electronic Letters*, Vol. 42, No. 10, 586–587, May 2006.
11. Weng, M. H., C. Y. Hung, and Y. K. Su, "A hairpin line diplexer for direct sequence ultra-wideband wireless communications," *Microwave Wireless Component Letters*, Vol. 17, No. 7, 519–521, July 2007.
12. Rambabu, K., M. Y. W. Chia, K. M. Chan, and J. Bornemann, "Design of multiple-stopband filters for interference suppression in UWB applications," *IEEE Transactions on Microwave Theory and Techniques*, Vol. 54, No. 8, 3333–3338, August 2006.
13. Ismail, A., M. S. Razalli, M. A. Mahdi, R. S. A. R. Abdullah, N. K. Nordin, and M. F. A. Rasid, "X-band trisection substrate-integrated waveguide quads-elliptic filter," *Progress In Electromagnetics Research*, PIER 85, 133–145, 2008.
14. Gan, H. L., D. X. Yang, and D. W. Lou, "Optimized design method of microstrip parallel-coupled bandpass filters with compensation for center frequency deviation," *PIERS Online*, Vol. 1, No. 3, 2005.

15. Chen, H. and Y.-X. Zhang, "A novel and compact UWB bandpass filter using microstrip fork-form resonators," *Progress In Electromagnetics Research*, PIER 77, 273–280, 2007.
16. Zhao, L.-P., X. Zhai, B. Wu, T. Su, W. Xue, and C.-H. Liang, "Novel design of dua-mode bandpass filter using rectangular structure," *Progress In Electromagnetics Research B*, Vol. 3, 131–141, 2008.
17. Ghorbaninejad, H. and M. Khalaj-Amirhosseini, "Compact bandpass filters utilizing dielectric filled waveguides," *Progress In Electromagnetics Research B*, Vol. 7, 105–115, 2008.
18. Naghshvarian-Jahromi, M. and M. Tayarani, "Miniature planar UWB bandpass filters with circular slots in ground," *Progress In Electromagnetics Research B*, Vol. 3, 87–93, 2008.
19. Razalli, M. S., A. Ismail, M. A. Mahdi, and M. N. Hamidon, "Ultra-wide band microwave filter utilizing quarter-wavelength short-circuited stubs," *Microwave Optical Technology Letters*, Vol. 50, No. 11, 2981–2983, November 2008.
20. Fooks, E. H. and R. A. Zakarevicius, *Microwave Engineering Using Microstrip Circuit*, Prentice Hall, Sydney, 1990.
21. Hong, J. S. and M. J. Lancaster, *Microstrip Filters for RF/Microwave Applications*, John Wiley & Sons Inc., New York, 2001.
22. Kirschning, R., H. Jansen, and N. H. L. Koster, "Measurement and computer-aided modeling of microstrip discontinuities by an improved resonator method," *IEEE MTT-S Int. Microwave Symposium Digest*, 495–497, 1983.
23. James, D. S. and R. J. P. Douville, "Compensation of microstrip bends by using square cutouts," *Electronic Letters*, Vol. 12, No. 22, 577–579, October 1976.
24. Hsieh, L. H. and K. Chang, "Compact, low insertion-loss, sharp-rejection, and wide-band microstrip bandpass filters," *IEEE Transactions on Microwave Theory and Techniques*, Vol. 51, No. 4, Part 1, 1241–1246, April 2003.
25. Chunfei, Y. and L. Erping, "Distributed capacitance and inductance of transmission lines by considering the effects from ends and bends," *International Symposium Electromagnetic Component*, 10–102, May 2002.
26. CST Microwave Studio 2006B.