

Numerical and Experimental Investigation of the Innovatory Incremental-Forming Process Dedicated to the Aerospace Industry



JOANNA SZYNDLER, FRANCISZEK GROSMAN, MAREK TKOCZ,
and LUKASZ MADEJ

The main goal of this work is development of the incremental-forming (IF) process for manufacturing integral elements applicable to the aerospace industry. A description of the proposed incremental-forming concept based on division of large die into a series of small anvils pressed into the material by a moving roll is presented within this article. A unique laboratory device has been developed to investigate the effects of process parameters on the material flow and the press loads. Additionally, a developed numerical model of this process with specific boundary conditions is also presented and validated to prove its predictive capabilities. However, main attention is placed on development of the process window. Thus, detailed investigation of the process parameters that can influence material behavior during plastic deformation, namely, roll size and roll frequency, is presented. Proper understanding of the material flow to improve the IF process, as well as press prototype, and to increase its technological readiness is the goal of this article. Results in the form of, *e.g.*, strain distribution or recorded forging loads are presented and discussed.

DOI: 10.1007/s11661-016-3487-6

© The Author(s) 2016. This article is published with open access at Springerlink.com

I. INTRODUCTION

DUE to the increased necessity for environmental protection, new materials, as well as innovative manufacturing solutions, are currently in high demand. As a result of strict European Union regulations, carbon dioxide emissions, noise emissions, and electricity consumption must be reduced during various manufacturing stages. At the same time, customers are demanding reduction in prices (production costs) and improvement in the quality of products. One possible solution to meet these requirements is a reduction in the weight of the commonly used conveyances (*i.e.*, cars, trucks, airplanes, and transport aircrafts). Such a solution makes it possible to reduce, *e.g.*, the amount of consumed fuel and, as a consequence, to reduce the amount of carbon dioxide emission into the atmosphere. A worldwide environmental protection policy insists on limiting factors that are dangerous to the natural environment, which were especially emphasized in the goals of the European Framework Program of Research and Innovation (2014–2020) – “Horizon 2020.” One of the main goals of this program is the production of greener and quieter aircrafts, vehicles, and ships, which will

contribute to the improvement of environmental protection by noticeable reduction in noise and vibrations. As a result, more and more research has been dealing with these issues. However, this research has been mostly concentrated on reduction in emission of harmful substances produced by an air transport. Such research has been clearly visible in 7th Framework Program projects, such as NINHA, X-NOISE EV, MARS, or DAEDALOS.

One of the suggested solutions is the successive decrease in aircraft weight by using lightweight composites. However, not every component of the aircraft body can be made from these light materials. This is obvious in the case of structural parts, which are crucial from a safety point of view and have to be characterized by high durability and load-carrying capacity. In these applications, metallic materials are still widely used to manufacture subsequent components, which are then assembled and joined together in the final product used in the aircraft construction. Thus, to reduce the weight of these assembled components, a so-called integral part made from lightweight alloys, *e.g.*, aluminum, titanium, or magnesium, can be introduced.

An integral element is made from one piece of material, which is equivalent to the product in a conventional approach that is made from many smaller parts.^[1] Avoidance of joints (welds, rivets), which weaken the whole component, causes the product to become lighter, more durable, and less susceptible to cracking in vital locations during exploitation. An integral parts concept is presented in Figure 1. Application of integral elements in the aerospace industry also enables reduction of the exploitation costs of other

JOANNA SZYNDLER, Ph.D. Student, and LUKASZ MADEJ, Professor, are with the AGH University of Science and Technology, Al. Mickiewicza 30, 30-059 Kraków, Poland. Contact e-mail: szyndler@agh.edu.pl FRANCISZEK GROSMAN, Professor, and MAREK TKOCZ, Assistant Professor, are with the Silesian University of Technology, Akademicka 2A, 44-100 Gliwice, Poland.

Manuscript submitted March 3, 2015.

Article published online May 2, 2016

aircraft components (e.g., tires), extends their lifespan, and lowers conservation costs and production outlay even up to 40 pct.^[1] The next important aspect of forming technology used during manufacturing of integral parts is a reduction of used energy as smaller number of elements have to be manufactured.

As presented, the advantages of integral parts are vast. Unfortunately, because of the complicated shapes and large area sizes, the forming of such components with traditional forging methods is difficult.^[1] Expenses related to the large capacity presses, manufacturing proper die shapes, as well as excessive wear related to significant loads drastically increase production costs. That is why, to obtain integral parts, a series of manufacturing technologies based on machining, rolling, extrusion, or casting were developed in recent years.^[2] Regrettably, most of them have excessive costs and technical problems, small efficiency, or limited applications. Therefore, development of an innovative incremental-forming (IF) process seems to be the best solution for obtaining integral elements.

II. INCREMENTAL FORMING

Incremental forming enables obtaining shapes impossible to acquire from conventional forming methods. The processes involved in incremental forming can be divided into two main groups: the sheet^[3–7] and the bulk^[8–12] forming methods. Examples of commonly used IF processes are presented in Figure 2 and described in detail in Reference 13.

The process of incremental forging is an interesting example of IF technology. Excessive loads recorded on the presses during, e.g., conventional forging are eliminated in the approach by division of the single die into a series of small anvils that realize complex deformation in a sequential manner, as shown in Figure 3.^[3] For this reason, widely available presses, with lower press load capacities, can be used to obtain integral elements. What is more, the IF process enables obtaining complex constructional elements during a single manufacturing process without the need for additional assembly operations. Such technology can also be successfully used to manufacture products from materials that are considered to be hardly deformable.^[3]

The main advantage of incremental forming is a possibility of lowering expected press loads and of increasing material deformation limits. Accordingly, based on the experience gained during the previous author's work,^[13] a detailed analysis of material



Fig. 1—Example of a part made from (a) many smaller elements in a conventional approach, (b) one piece of material—integral element.

behavior during the proposed innovative process of incremental forming of integral elements dedicated to the aerospace industry was presented within the article.

The developed incremental metal-forming approach can be defined as a process where indentations of a large area and a big depth are obtained by accumulation of small indentations made consecutively by individual segments/anvils on a relatively small working surface. Based on the experience obtained during previous experiments with the orbital press enriched by a specific tooling,^[13–15] a new, unique laboratory device for bulk incremental forming has been developed, constructed, and mounted in the working space of a hydraulic press at the Faculty of Material Science and Metallurgy of the Silesian University of Technology. Schematic illustration of the press concept is shown in Figure 4, while details of the assembled experimental setup are presented in Figure 5.

As shown in Figure 5, a workpiece is in the form of a plate characterized by high surface/thickness ratio.

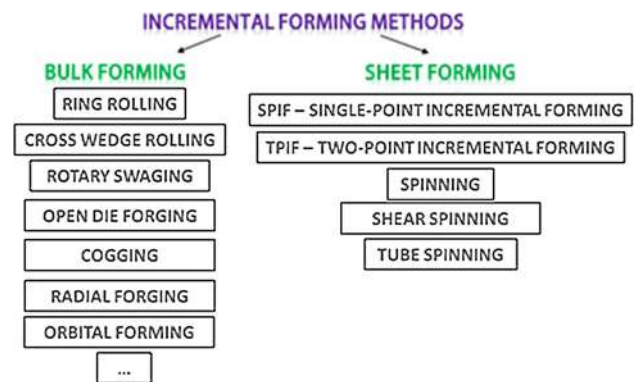

Fig. 2—Examples of IF processes.

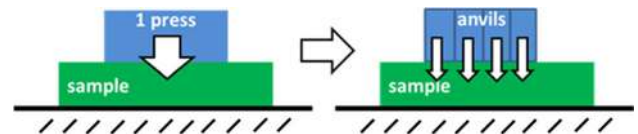

Fig. 3—Idea of an IF approach.

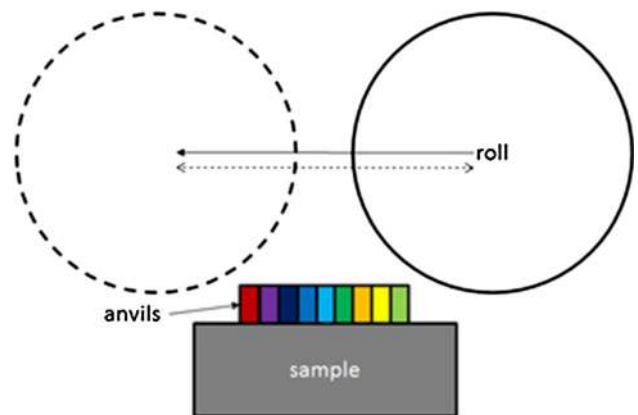

Fig. 4—Illustration of developed IF process.

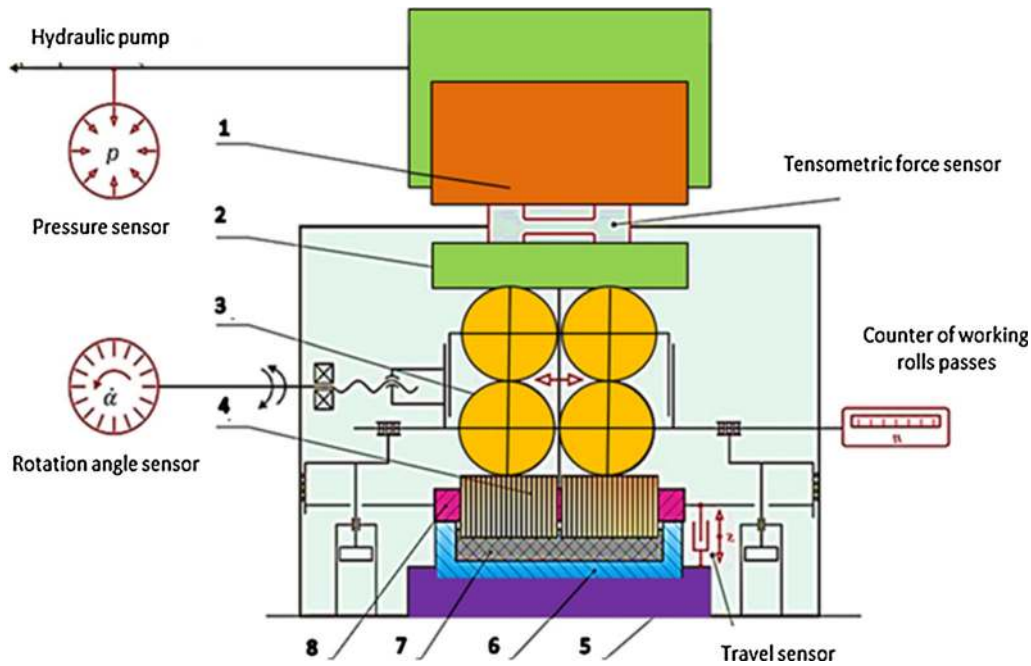

Fig. 5—Diagram of the developed device for incremental forming equipped with sensors for precise process control and data acquisition system: 1—punch, 2—pressure plate, 3—working rolls, 4—segmental punch, 5—press table, 6—die, 7—workpiece, and 8—punch retainer.



Fig. 6—Test stand for incremental forming process: (a) anvils, (b) anvils put in a test stand, (c) hydraulic press, (d) work station zoomed view, and (e) work station with anvils prepared for IF process.

Punch segments are grouped and located in several sectors of a punch retainer. During the test, anvils are pressed against the workpiece located tightly in a die by working rolls, which move crosswise in a reciprocating manner. As the workpiece thickness under punch

segments systematically decreases, an excess material fills a free space between the punch sectors and along the die walls. Thus, stiffening ribs can be created, which is of importance from a practical application point of view.

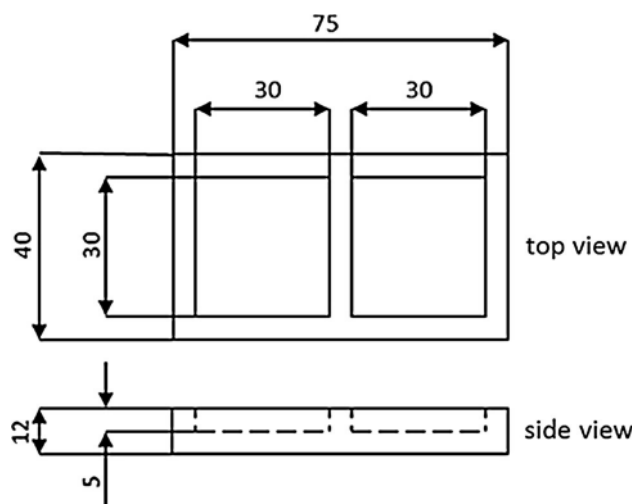

Fig. 7—Schematic drawing of a model of expected integral element (mm).

During this process, only a few small areas of the workpiece surface are under pressure at the same time. Consequently, a comparatively low press load is required to realize a plastic deformation of a material. As mentioned, this is the most important advantage of the presented method because it can be applied even on presses, which dispose relatively small maximum press loads. To realize the presented concept despite the hydraulic press, an additional engine used to control roll movement has to be involved.

Thus, to successfully apply proposed innovative forming technology at the industrial scale, engineers have to gain detailed knowledge of the mechanisms that control deformation and microstructure evolution during complex manufacturing conditions. For this reason, a unique laboratory device for bulk incremental forming based on Figure 5 has been developed, and it is presented in the following section.

III. EXPERIMENTAL RESEARCH

Experimental research was conducted with a specially developed test stand that is presented in Figure 6.^[16] Additionally, a developed device required for the IF process was installed within the working area of the conventional hydraulic press characterized by 1.5MN (150 T) load.

The press prototype was equipped with a computer control system and measuring/registration system that enabled a precise acquisition of data recorded during the test. The parameters that could be set and then registered during the forming process were as follows: velocity and press load, vertical displacement of the press stamp, indentation of anvils that deform the material (displacement of rolls that press subsequent anvils), and the frequency and amplitude of the rolls' horizontal movement.

Developed equipment was tested on a simplified geometry composed of two sets of six anvils and one

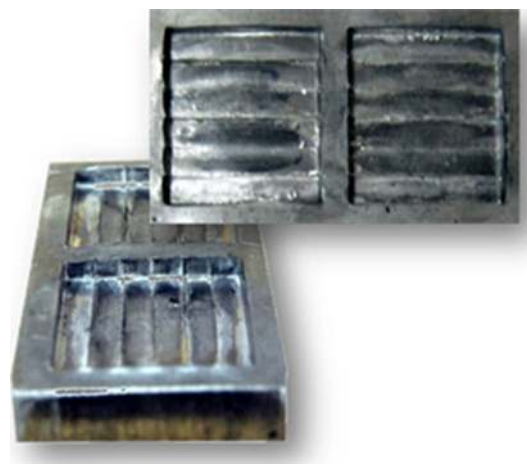

Fig. 8—Panel shapes obtained from the IF press prototype.

working roll. Commercially pure aluminum was selected for the experimental investigation. The sample dimensions are $75 \times 40 \times 10 \text{ mm}^3$ as shown in Figure 7.

Panel shapes that were obtained during initial experiments are presented in Figure 8. The number and distribution of ribs depends on the geometrical features of tooling. Intelligently designed ribs can provide required stiffness in the specific areas of the panel.

Performed analysis of material behavior at the macro-scale level revealed a high plastic deformation penetration within the material, as shown in Figure 9. The characteristic periodic-type fiber alignment, which is compatible with the thickness of the single anvil, is clearly visible. These fibers strengthen the surface of the obtained part, which is a very positive effect. Such positive material behavior can be obtained during forging and is impossible to receive during, *e.g.*, machining or casting. Obtained results in the form of recorded press loads and displacements in the function of time are presented in Figure 10. The applied load was systematically increased: 60, 100, 150, 240, 320, 390, and 440 kN with defined time periods. For each press load, the roll realized approximately 10 reciprocating passes from one side to the other.

As shown in Figure 10, to initiate the process of subsequent anvils indentation, it is necessary to exert a threshold force, which, for the analyzed case is equivalent approximately to 100 kN. It can also be noticed that the higher the press load value is, the higher the indentation value, as well as the velocity of indentation. The velocity of anvil indentation is expressed by increasing the angle of inclination line that represents the value of indentation in a function of time. This is especially visible for the press load approximately to 400 kN, where the indentation velocity reached 0.02 mm/s.

Visible defects in obtained parts after the process in the form of overflows between anvils are caused by insufficient press stiffness, which results in excessive deviation of the resistance plate that transfers the load to the rolls. A new, stiffer press frame should be developed to minimize this behavior.

To support the presented experimental research, which is expensive and time consuming, a numerical

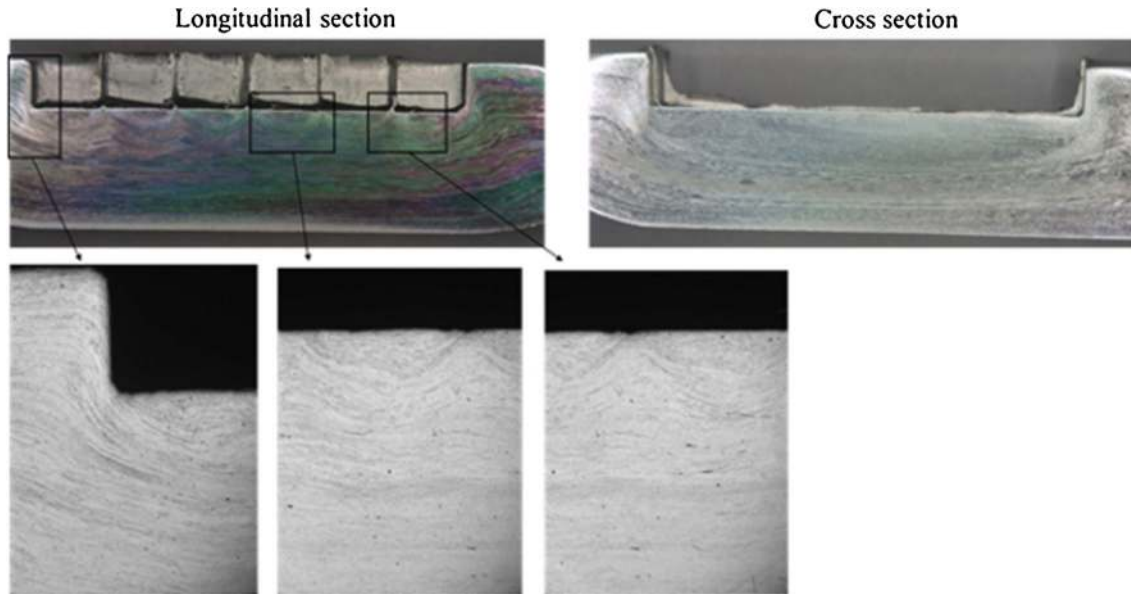

Fig. 9—Fiber alignment obtained during incremental forming of integral element.

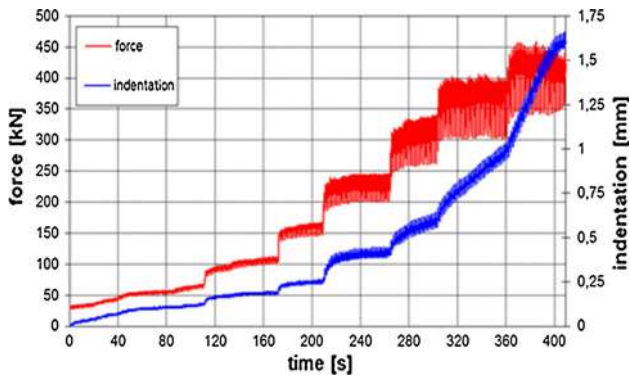

Fig. 10—Recorded press loads (red color) and displacements (blue color) as a function of time during IF process (Color figure online).

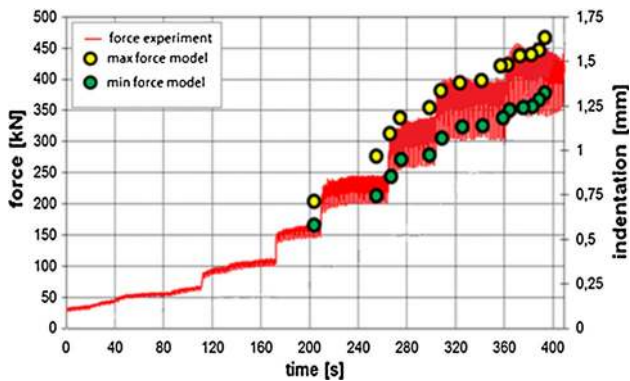

Fig. 11—(a) Comparison of press load obtained during laboratory research (red color) and numerical simulation (green dots—minimum registered value, yellow dots—maximum registered value) (Color figure online).

analysis for the IF process was proposed by using computer models capable of replicating experimental observations. That way, a robust process window can be

evaluated and used during further experimental investigation.

IV. NUMERICAL ANALYSIS

A numerical model was created on the basis of the commercial Forge 2005 finite element code devoted to numerical simulations of large plastic deformation processes. Forge 2005 code is based on the viscoplastic flow rule with the Norton-Hoff law^[17] in the form:

$$\sigma_{ij} = 2K(\sqrt{3}\dot{\epsilon}_i)^{m-1} \dot{\epsilon}_{ij} \quad [1]$$

where σ_{ij} is the deviatoric stress tensor, $\dot{\epsilon}_{ij}$ is the strain rate tensor, $\dot{\epsilon}_i$ is the effective strain rate, K is the material consistency, and m is the strain rate sensitivity coefficient. K is the material parameter, which represents the flow stress and is calculated from the following equation:

$$K = \frac{\sigma_p}{\sqrt{3}(\sqrt{3}\dot{\epsilon}_i)^m} \quad [2]$$

Those two equations lead to the classic Levy–Mises flow rule describing the relationship between the deviatoric stress and the strain rate tensor:

$$\sigma_{ij} = \frac{2}{3} \frac{\sigma_p}{\dot{\epsilon}_i} \dot{\epsilon}_{ij} \quad [3]$$

The code is a fully thermomechanical model taking into account the influence of temperature changes:

$$\rho c \frac{\Delta T}{\delta t} = \text{div}(k \text{ grad } T) + \dot{W} \quad [4]$$

where ρ is the material density, c is the specific heat capacity, T is the temperature, t is the time, k is the

thermal conductivity factor, and \dot{W} is the internal energy dissipation. The heat generated during deformation is calculated with the following equation:

$$\dot{W} = \eta \sigma_{ij} \dot{\epsilon}_{ij} = \eta K \sqrt{3} \dot{\epsilon}^{m_1+1} \quad [5]$$

where η is the strain efficiency (also named the “heat conversion efficiency” $\eta = \frac{1}{1+m}$).

The developed model was validated with the experimental results obtained from first trials realized on the press prototype. Thus, the geometry and the setup of the numerical model exactly replicated the experimental setup described earlier. The moving roll with a 50 mm radius was subsequently pressing 12 anvils, aligned into two rows, as shown in Figure 6, into the aluminum workpiece at a final indentation depth equal to 1.5 mm.

The classic Hansel–Spittel material flow stress model with coefficients obtained due to the inverse analysis was used during the investigation:

$$\sigma = A e^{m_1 T} T^{m_9} \dot{\epsilon}^{m_2} e^{m_4/\dot{\epsilon}} (1 + \dot{\epsilon})^{m_5} T e^{m_7 \dot{\epsilon}} \dot{\epsilon}^{m_3} \dot{\epsilon}^{m_8} T \quad [6]$$

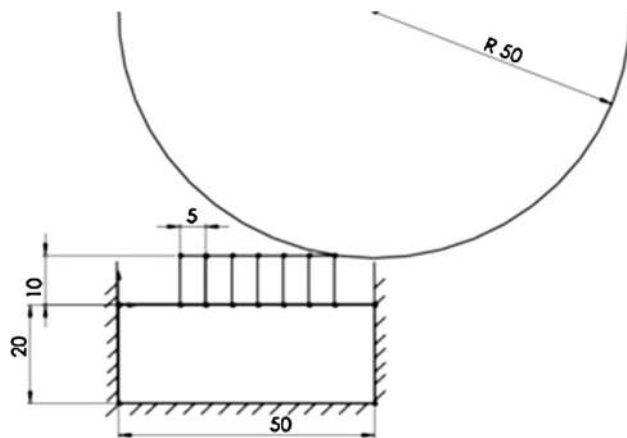

Fig. 12—Simulation setup of the developed IF process.

where σ is the flow stress; $\dot{\epsilon}$ is the equivalent strain; $\dot{\epsilon}$ is the equivalent strain rate; T is the temperature in °C; and the model coefficients: $A = 139.0000011$, $m_1 = -0.00184706$, $m_2 = 0.0623991$, $m_3 = 0.009336435$, $m_4 = -1.76441E-05$, $m_5 = -0.001861512$, $m_7 = 0.063127492$, $m_8 = 7.17027E-05$, and $m_9 = 0.038132999$.

Comparison of the recorded and calculated press loads is shown in Figure 11.

The yellow dots in Figure 11 represent the maximum recorded press loads for a particular indentation value during simulation. Green dots represent the minimum recorded press loads, respectively. As can be seen, differences between experiment and numerical results are small, with a tendency for smaller higher values predicted by the model, which may be associated with

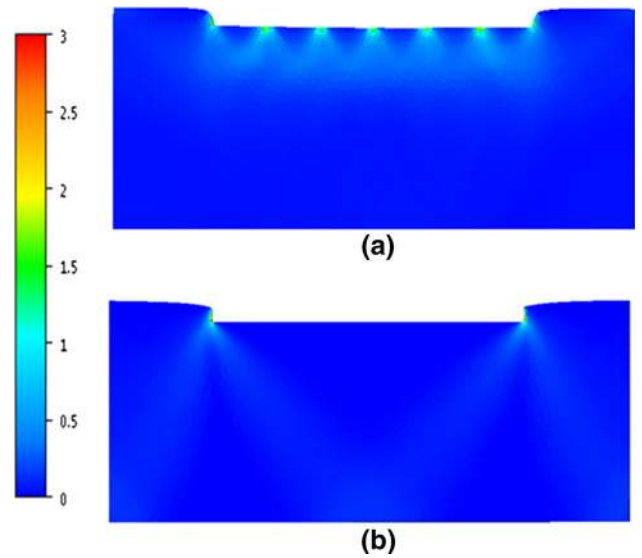

Fig. 14—Strain distribution results after (a) incremental-forming and (b) conventional-forging process (Color figure online).

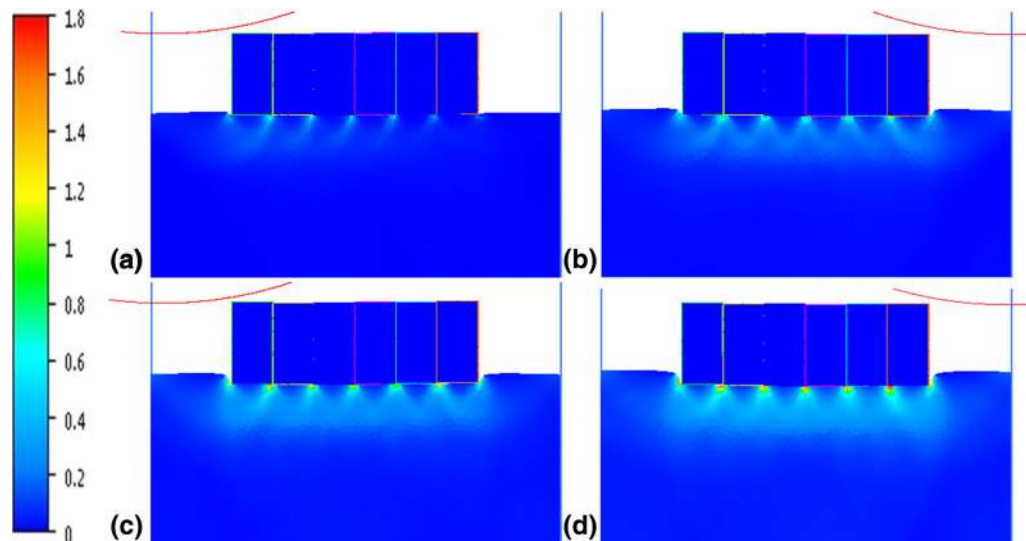

Fig. 13—Strain distribution results after (a) 1, (b) 2, (c) 3, (d) 4 roll pass during IF process (Color figure online).

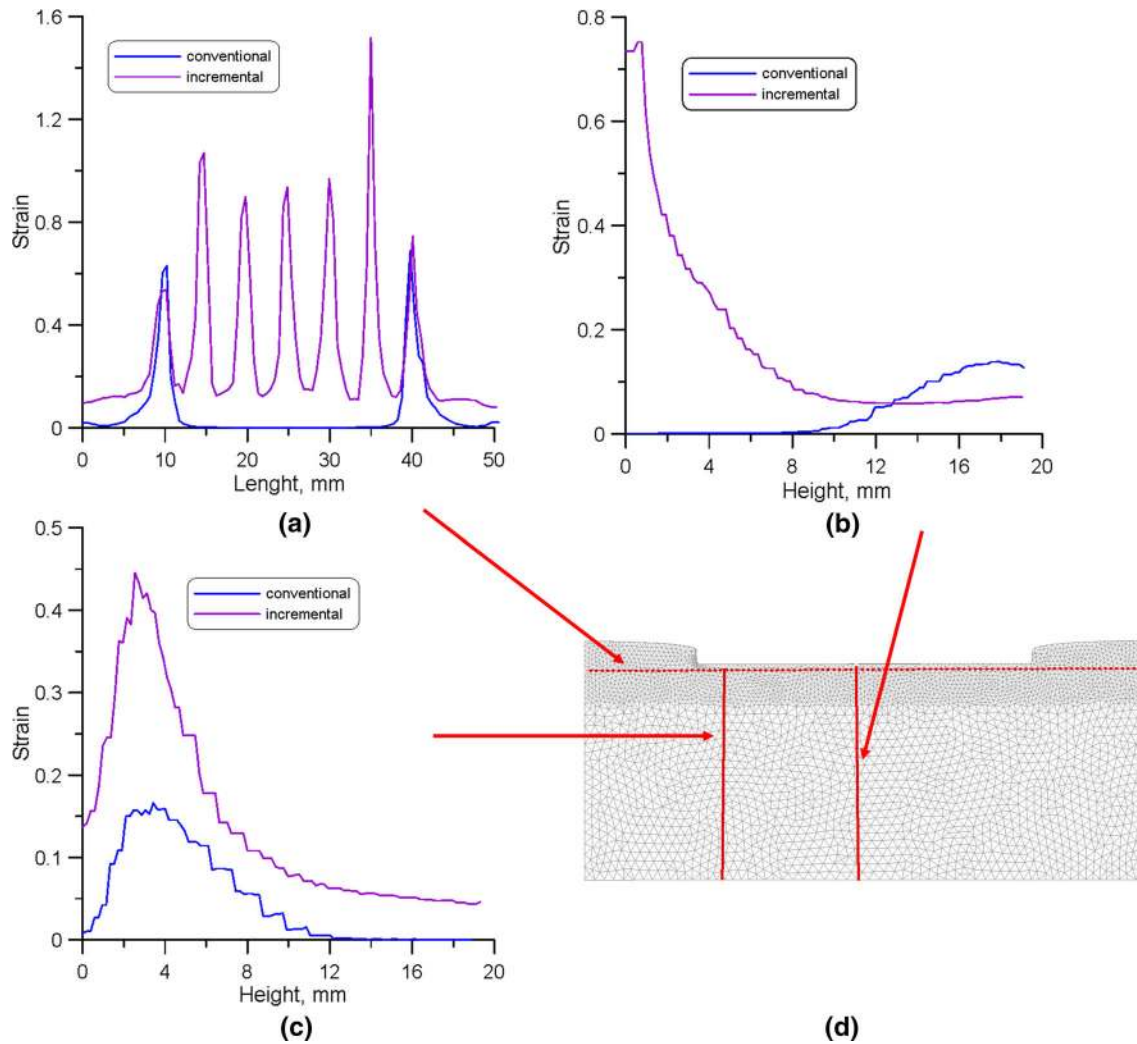

Fig. 15—Equivalent strain values recorded after the conventional- and incremental-forming process, (a) near the top of the surface, (b) along vertical line in the middle of the sample—between anvils, (c) along vertical line under the first anvil, and (d) location of measurement lines (Color figure online).

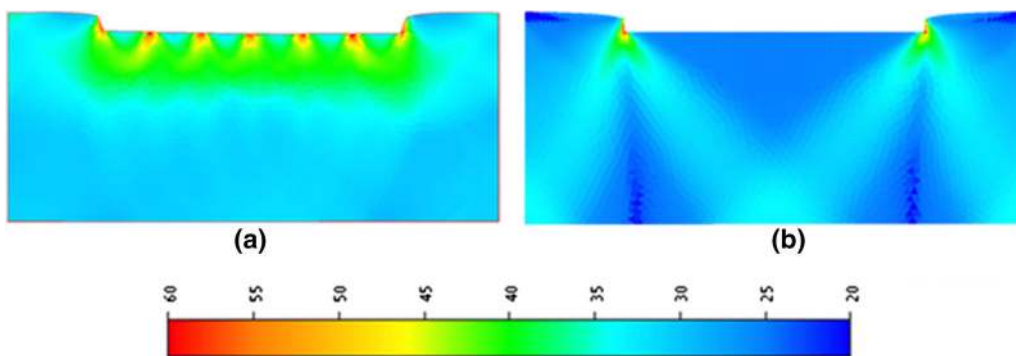

Fig. 16—Vickers hardness distribution after (a) incremental-forming and (b) conventional-forging process (Color figure online).

the assumption of perfectly rigid dies during numerical modeling.

The earlier presented investigation proves that it is possible to obtain reliable results from numerical model of the proposed IF process, which agree well with real material behavior observed during laboratory tests.

Thus, after the validation stage, it is possible to use the model for more detailed investigations focused on material flow near subsequent anvils during the IF deformation and compare it with conventional forging. The commercially pure aluminum material flow stress model was again used to provide information on

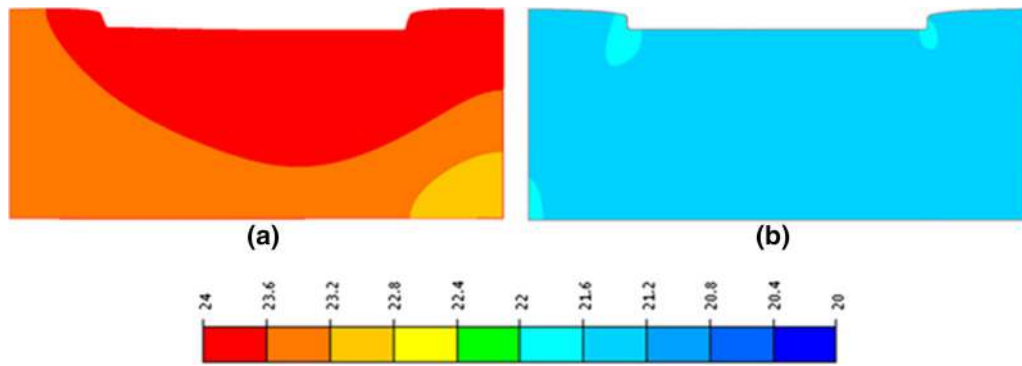

Fig. 17—Temperature distribution after (a) incremental-forming and (b) conventional-forging process in °C. (In Kelvin, add 273.15 to °C) (Color figure online).

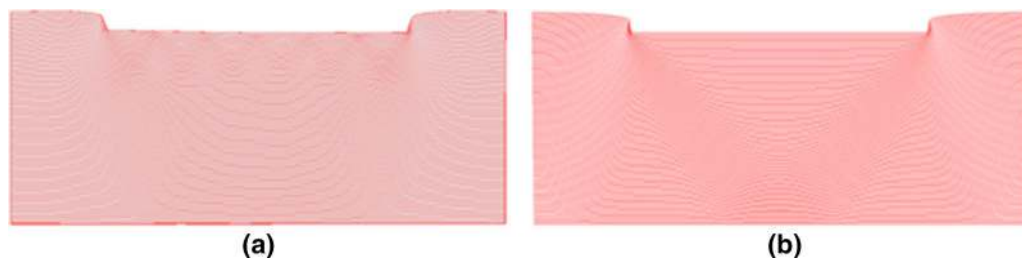

Fig. 18—Material flow lines after (a) incremental-forming and (b) conventional-forging process.

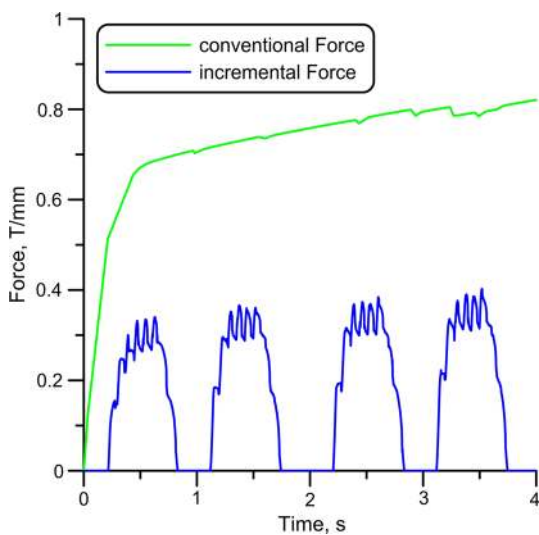

Fig. 19—Loads recorded during conventional and incremental forming (Color figure online).

fundamental material behavior not affected by alloying elements. Again, the flow stress model described by Hansel–Spittel (Eq. [6]) was used.

To speed up the simulation process, a simplified deformation scheme was applied, which is composed of only four passes of working roll with frequency that equals 0.5 Hz and the pressing depth per pass of 0.2 mm. Such indentation depth provides significant reduction in manufacturing time and still minimizes the probability of, e.g., material overflows, which was investigated in earlier work by these authors.^[18] Specimen and anvil

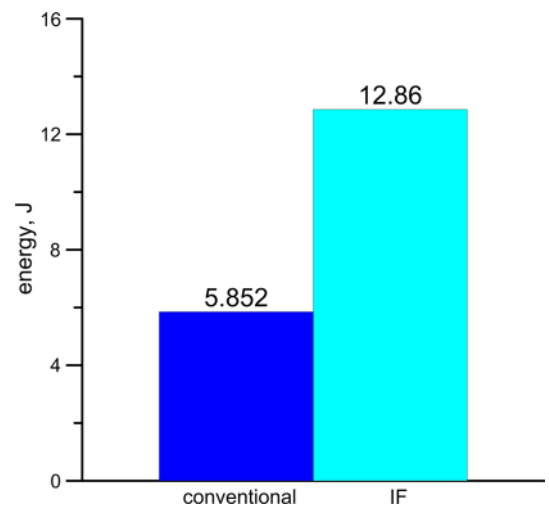

Fig. 20—Work obtained after conventional and incremental forging.

dimensions are $50 \times 20 \text{ mm}^2$ and $5 \times 10 \text{ mm}^2$, respectively. Dimensions of the model are presented in Figure 12. Similar to the previous investigation, the material flow is constrained on both sides of the sample to produce strengthening ribs due to the backward extrusion.

Obtained results in the form of strain distribution after each pass are shown in Figure 13. Comparison between strain distribution after incremental and conventional forming for the same process conditions is presented in Figure 14 and in detail some interesting locations in Figure 15. Differences between the two

approaches are also visible when Vickers hardness, temperature, and material flow lines distributions are investigated as shown in Figures 16 through 18. Finally, differences between loads recorded in both horizontal and vertical directions during conventional and incremental forming are shown in Figure 19.

Results in Figures 14 and 15 clearly show that after conventional forming, high strain values are concentrated in sample areas that are in contact with upper die edges, which may lead to material failure. On the other hand, results obtained during incremental forming

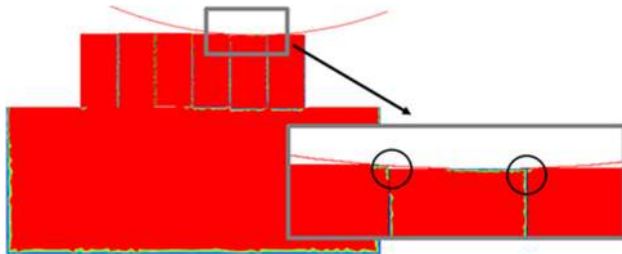

Fig. 21—Contact observed between sample and dies during IF process.

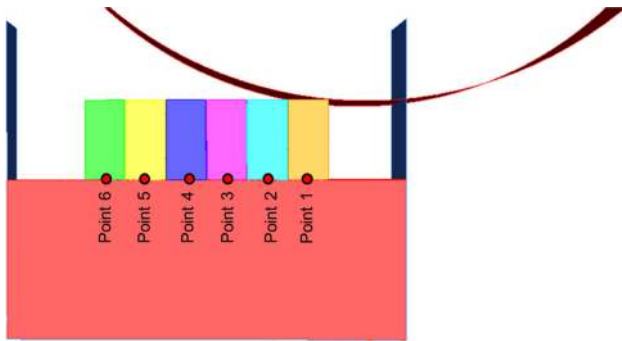

Fig. 22—Visualization of control points selected for a material flow analysis.

reveal that the strain values rise along the surface and in the areas between anvils due to the strain path change effect, which can be also seen in the experimental research presented above. Similar material behavior can be observed in the case of hardness distribution calculated during the simulation. After IF process higher hardness values are recorded near the top part of the sample, especially in the areas between anvils. Moreover, after incremental forming, higher hardness values can be seen in the entire sample unlike after conventional forging, where hardness distribution is also less uniform. These high strain and hardness values that are evenly distributed along the sample surface will result in better in use properties of the final component and will minimize the risk of material failure.

Temperature distribution presented in Figure 17 shows that after the incremental process, the maximum recorded value is 270 K (3 °C) higher than after conventional forging. It is again connected with the strain path change, which is noticeable during the IF process. Nonsymmetrical temperature distribution after the IF process is strictly connected with the end point of roll movement. Finally, material flow lines (Figure 18) also accurately describe material behavior in both incremental and conventional forging. These results are very similar to fibers alignment obtained during the experimental test presented in Figure 9.

Interesting behavior is also observed in the case of the load recorded during the simulation presented in Figure 19. Obtained results highlight the main advantage of the new process—reduction in loads required for material deformation. During the incremental forming, the recorded load is 50 pct lower than in the conventional forming and it is expected that for the case where the indentation depth equals the final sample thickness, this load reduction will be even more pronounced. It is also expected that this reduction will be even higher when a smaller diameter of the working roll, higher number of anvils, or smaller indentation value per one roll pass will be used during the process. However,

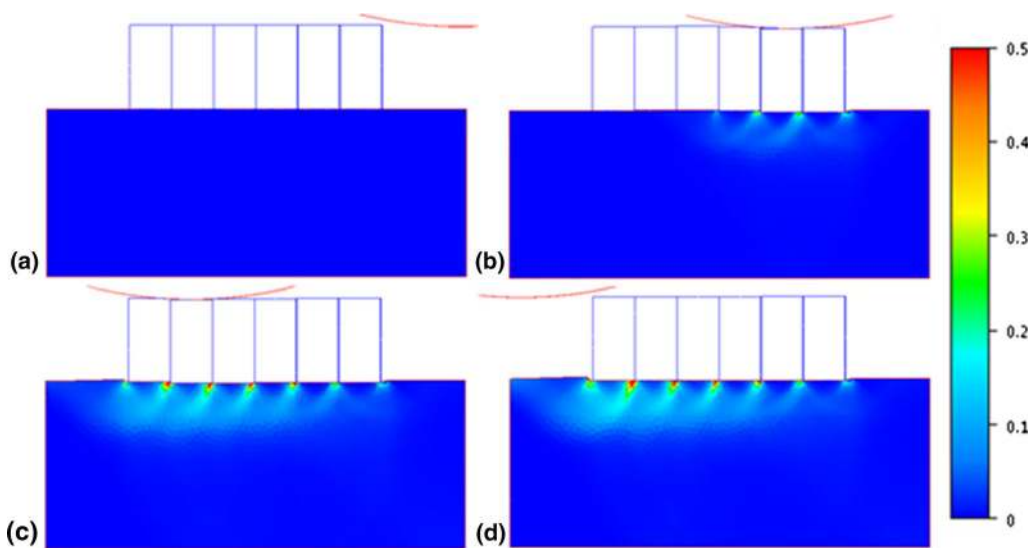

Fig. 23—Strain distribution during 1st roll pass: (a) before, (b) 2nd anvil load, (c) 5th anvil load, and (d) after roll pass (Color figure online).

because of the reciprocating character of roll movement, energy accumulated during IF deformation is significantly higher than during conventional forging as shown in Figure 20. In the conventional forging case, the energy is calculated as an integral from the force-displacement plot, where displacement in the vertical direction equals 0.8 mm. In the IF process, the energy is also an integral from the force-displacement plot but calculated for each anvil separately and finally summed. In conclusion, the total energy accumulated during the IF process is two times higher than during the conventional-forming process. However, as mentioned, the main advantage of the IF process is the possibility of forming hardly formable materials on presses with smaller load capacities. Energy efficiency is not the focus at this stage of the research.

Some oscillations of load values in Figure 19, which are visible during subsequent roll passes, are due to different numbers of anvils that are simultaneously pressed into the material. The roll currently used can be in contact with maximum three anvils at the same time, which is shown in Figure 21. The higher the amount of anvils in contact with the roll, the smaller the effect of incremental deformation that is observed, and load values increase.

To have a better view of this situation, an additional analysis was performed. Six points under subsequent anvils were selected for the analysis, as presented in

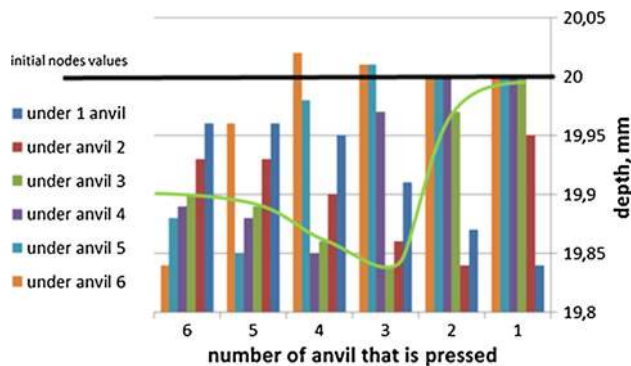

Fig. 24—History of control points coordinates during single roll pass of IF process (Color figure online).

Figure 22. Strain distribution after pressing subsequent anvils up to the maximum indentation depth by the moving roll during one pass was also investigated in Figure 23. The evolution of investigated point coordinates during a single roll pass is evaluated in Figure 24. Also, displacement vectors during the first roll pass analyzed for the IF process were compared with the conventional forging result for corresponding indentation depth (Figure 25).

Obtained results, as expected, show that during a single roll pass, strain values are much higher at the end of the roll movement than at the beginning (Figure 23(d)). It is caused by the material flow during subsequent anvil indentation into the workpiece.

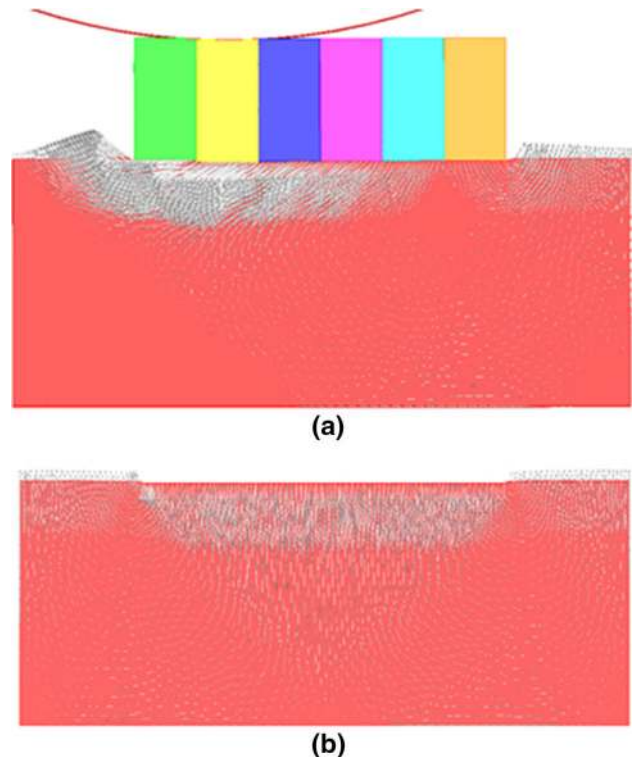

Fig. 25—Displacement vectors during (a) incremental-forming and (b) conventional-forging process.

Indentation depth per 1 roll pass	f = 0.1 Hz								f = 0.5 Hz								f = 1 Hz							
	roll diameter, mm								roll diameter, mm								roll diameter, mm							
	10	20	30	40	60	80	100	10	20	30	40	60	80	100	10	20	30	40	60	80	100			
0.5 mm	•	•	•	•	•	•	•	•	•	•	•	•	•	•	•	•	•	•	•	•	•			
0.45 mm	•	•	•	•	•	•	•	•	•	•	•	•	•	•	•	•	•	•	•	•	•			
0.4 mm	•	•	•	•	•	•	•	•	•	•	•	•	•	•	•	•	•	•	•	•	•			
0.35 mm	•	•	•	•	•	•	•	•	•	•	•	•	•	•	•	•	•	•	•	•	•			
0.3 mm	•	•	•	•	•	•	•	•	•	•	•	•	•	•	•	•	•	•	•	•	•			
0.25 mm	•	•	•	•	•	•	•	•	•	•	•	•	•	•	•	•	•	•	•	•	•			
0.2 mm	•	•	•	•	•	•	•	•	•	•	•	•	•	•	•	•	•	•	•	•	•			
0.15 mm	•	•	•	•	•	•	•	•	•	•	•	•	•	•	•	•	•	•	•	•	•			
0.1 mm	•	•	•	•	•	•	•	•	•	•	•	•	•	•	•	•	•	•	•	•	•			

Fig. 26—Combinations of investigated process parameters.

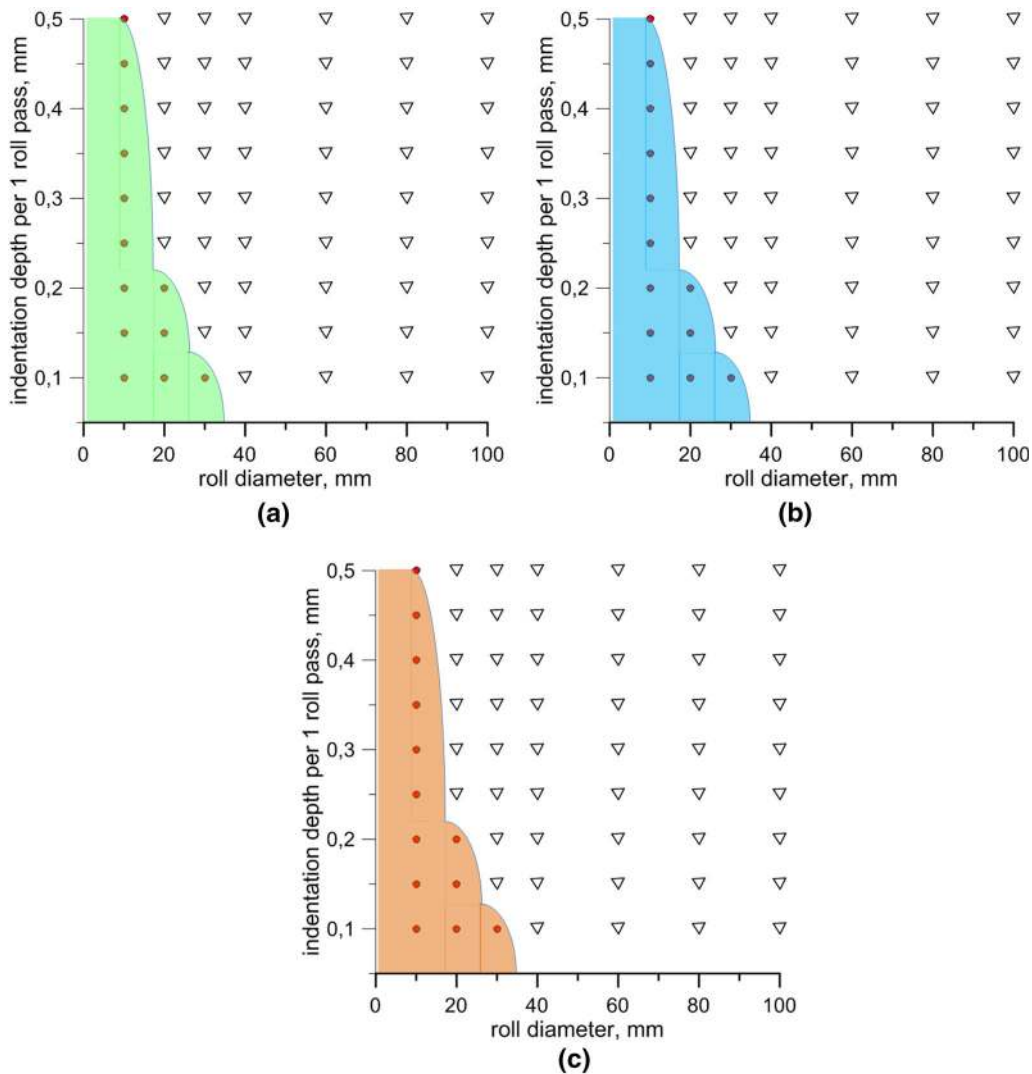

Fig. 27—Visualization of acceptable (red dots) and not acceptable (triangles) IF process parameters for (a) 0.1-, (b) 0.5-, and (c) 1-Hz roll frequency (Color figure online).

Material is pushed from the right to the left side as the roll is moving (Figure 25(a)). The direction of material flow is determined by the direction of roll movement. What is more, during this IF process, material is also pushed up in a vertical direction, which causes particular anvils to also be pushed up, and this is why the roll can be in contact with additional, unexpected anvils. For example, in Figure 24, it is observed that the material coordinates from points 5 and 6 exceed the initial level of the sample surface when the 3rd and 4th anvil is loaded by the roll (roll is located halfway through one pass). To solve that problem, a system of pawls can be added to the press prototype, which will keep pressed anvils at the indentation level and hold up the material flow in a vertical direction. However, such a solution is connected to additional modification of the press and will be considered in later test stand modernization. Also, a larger roll size could be used to hold anvils, but if we want to maintain the incremental character of this process, the smallest possible number of anvils should be in contact at the same time with the moving roll. The problem of such material flow in a vertical direction can be solved by using

a smaller roll or smaller indentation values per one roll pass. To address the problem and to define appropriate process parameters, where the moving roll will be in contact with at most two anvils at the same time, a series of calculations can be performed. The influence of three process parameters was investigated to evaluate a process window for the incremental forging:

- roll size (10, 20, 30, 40, 60, 80, 100 mm),
- roll frequency (0.1, 0.5, 1 Hz),
- value of indentation depth (0.1, 0.15, 0.2, 0.25, 0.3, 0.35, 0.4, 0.45, 0.5 mm) per one roll pass.

Combinations of investigated process parameters are presented in Figure 26. A roll frequency parameter refers to the roll movement during the IF process: 1 Hz means that during 1 second, 1 roll cycle is done. One roll cycle is a roll move from one side to the other and backward. Thus, 0.5 Hz means 0.5 roll cycle (in this case, roll moves to one side) in 1 second, and 0.1 Hz means 0.1 roll cycle in 1 second.

After calculation based on the developed numerical model, acceptable combinations are presented in the

form of process maps: red dots represent acceptable conditions, where the moving roll is in contact with a maximum of 2 anvils at the same time. This is essential for maintaining the incremental character of the process. Triangles represent process conditions when the working roll was in contact with three or more anvils at the same time, which is an unacceptable behavior for the IF process character (Figure 27).

After a detailed analysis of the quality of obtained results during the novel IF process for different process parameters, it can be seen that the roll frequency has no influence on material behavior during deformation. This observation can be useful from a priceless production time point of view. However, the higher the roll diameter, the lower the indentation depth can be set to maintain a maximum of two press stamps in contact with the moving roll.

V. CONCLUSIONS

The concept of a new IF process for obtaining light and durable integral elements was proposed in this article. A unique laboratory device has been developed to investigate the effects of process parameters on material flow and press loads. Additionally, a complex developed numerical model of this process with specific boundary conditions was presented. Based on performed experimental and numerical research, it can be concluded that:

- Results obtained during numerical analysis are in qualitative agreement with the experimental research,
- The proposed IF process with a moving roll will be able to deliver integral elements with strengthening ribs.
- During incremental forming, strain and hardness values accumulate uniformly along the sample surface.
- After incremental forming, hardness distribution is more uniform across the sample than after conventional forging.
- During the IF process, the strain path change effect leads to strain concentration between anvils.
- The higher the indentation value of a single anvil, the higher the press load is recorded during the IF process.
- During IF, a recorded load is lower than during conventional forming.
- During IF, recorded energy is much higher than during conventional forming.
- There is no influence of different roll frequency on the quality of the obtained results.
- The smaller the roll diameter, the higher the indentation depth per one roll pass that can be obtained.

ACKNOWLEDGMENTS

Financial support from the Structural Funds in the Operational Programme - Innovative Economy (IE OP) financed from the European Regional Development Fund – “Project Modern material technologies in aerospace industry”, Nr POIG.01.01.02-00-015/08-00, is gratefully acknowledged.

OPEN ACCESS

This article is distributed under the terms of the Creative Commons Attribution 4.0 International License (<http://creativecommons.org/licenses/by/4.0/>), which permits unrestricted use, distribution, and reproduction in any medium, provided you give appropriate credit to the original author(s) and the source, provide a link to the Creative Commons license, and indicate if changes were made.

REFERENCES

1. T. Wiślicki: *Technologia budowy płatewów*, Wydawnictwa Naukowe – Techniczne, Warszawa, 1964.
2. J. Szyndler and L. Madej: *Comput. Methods Mater. Sci.*, 2015, vol. 15, p. 2.
3. G. Hussain and L. Gao: *Int. J. Mach. Tool. Manuf.*, 2007, vol. 47, pp. 419–35.
4. H. Isekia and T. Naganawab: *J. Mater. Process. Technol.*, 2002, vols. 130–1, pp. 675–79.
5. G. Hussain, L. Gao, and N.U. Dar: *J. Mater. Process. Technol.*, 2002, vol. 186, pp. 45–53.
6. S.J. Yoon and D.Y. Yang: *CIRP Ann. Manuf. Technol.*, 2005, vol. 54, pp. 221–24.
7. L. Filicel, L. Fratin, and F. Micari: *CIRP Ann. Manuf. Technol.*, 2002, vol. 51, pp. 199–202.
8. K. Muszka, L. Madej, and J. Majta: *Mater. Sci. Eng. A*, 2013, vol. 574, pp. 68–74.
9. T.F. Stanistreet, J.M. Allwood, and A.M. Willoughby: *J. Mater. Process. Technol.*, 2006, vol. 177, pp. 630–33.
10. P. Groche, D. Fritsche, E.A. Tekkaya, J.M. Allwood, G. Hirt, and R. Neugebauer: *CIRP Ann. Manuf. Technol.*, 2007, vol. 56, pp. 635–56.
11. C.C. Wong, T.A. Dean, and J. Lin: *J. Mater. Process. Technol.*, 2004, vols. 153–154, pp. 60–66.
12. Y. Jin and M. Murata: *J. Mater. Process. Technol.*, 2004, vols. 155–156, pp. 1810–14.
13. F. Grosman, L. Madej, S. Ziolkiewicz, and J. Nowak: *J. Mater. Process. Technol.*, 2012, vol. 212, pp. 2200–09.
14. F. Grosman, K.J. Kurzydłowski, J. Pawlicki, and L. Tomecki: Patent No. 210904.
15. J. Nowak, L. Madej, F. Grosman, and M. Pietrzyk: *Mater. Sci. Forum*, 2010, vols. 654–656, pp. 1622–25.
16. M. Tkocz and F. Grosman: *Solid State Phenom.*, 2014, vol. 212, pp. 243–46.
17. J.L. Chenot and F. Bay: *Mat. Proc. Tech.*, 1998, vols. 80–81, pp. 8–15.
18. J. Szyndler, L. Madej, and F. Grosman: *J. Mach. Eng.*, 2014, vol. 14, pp. 84–93.