

Utah State University

DigitalCommons@USU

Reports

Utah Water Research Laboratory

January 1975

Nutrient Dynamics and Gas Production in Aquatic Ecosystems: The Effects and Utilization of Mercury and Nitrogen in Sediment- Water Microcosms

D. B. Porcella

V. D. Adams

P. A. Cowan

S. Austrheim-Smith

W F. Holmes

J. Hill IV

See next page for additional authors

Follow this and additional works at: https://digitalcommons.usu.edu/water_rep



Part of the [Civil and Environmental Engineering Commons](#), and the [Water Resource Management Commons](#)

Recommended Citation

Porcella, D. B.; Adams, V. D.; Cowan, P. A.; Austrheim-Smith, S.; Holmes, W F.; Hill IV, J.; Grenney, W. J.; and Middlebrooks, E. J., "Nutrient Dynamics and Gas Production in Aquatic Ecosystems: The Effects and Utilization of Mercury and Nitrogen in Sediment-Water Microcosms" (1975). *Reports*. Paper 153.

https://digitalcommons.usu.edu/water_rep/153

This Report is brought to you for free and open access by the Utah Water Research Laboratory at DigitalCommons@USU. It has been accepted for inclusion in Reports by an authorized administrator of DigitalCommons@USU. For more information, please contact digitalcommons@usu.edu.



Authors

D. B. Porcella, V. D. Adams, P. A. Cowan, S. Austrheim-Smith, W F. Holmes, J. Hill IV, W. J. Grenney, and E. J. Middlebrooks

**NUTRIENT DYNAMICS AND GAS PRODUCTION IN AQUATIC
ECOSYSTEMS: THE EFFECTS AND UTILIZATION OF
MERCURY AND NITROGEN IN SEDIMENT-WATER
MICROCOSMS**

by

**D. B. Porcella, V. D. Adams, P. A. Cowan,
S. Austrheim-Smith, W. F. Holmes, J. Hill IV,
W. J. Grenney, and E. J. Middlebrooks**

The work reported by this project completion report was supported in part with funds provided by the Department of the Interior, Office of Water Research and Technology under P.L. 88-379, Project Number B-081-Utah, Agreement Number 14-31-0001-3942.

**Utah Water Research Laboratory
College of Engineering
Utah State University
Logan, Utah 84322**

November 1975

PRWG121-1

ABSTRACT

Sixteen sediment-water microcosms designed to allow complete gas, liquid, and solid mass balances of gases, nutrients, and mercury were studied under dark conditions or varying light intensity for a period of 189 days. Results indicated that the microcosm technique is a very sensitive method of analyzing microbial dynamics in sediment water systems. Gas quantity and composition changes were easy to monitor and were especially sensitive to light and nutrient variations. Nitrogen fixation occurred in all lighted systems (blue-green algae nitrogen fixers, *Anabaena*, and others) and was adequate to insure that no nitrogen limitation occurred even though nitrogen limitation was imposed on the system. Sediments apparently did not act as a significant source of nitrogen. Iron and phosphorus were in excess and as such were closely linked as would be predicted on the basis of chemical equilibria. Non-equilibrium chemical behavior of such elements would apparently result only when appreciable amounts of the compound or element is utilized in growth.

The microcosm technique is an excellent method for showing nutrient dynamics in sediment-water systems; the control of environmental variables allows interpreting at least some of the major factors which control productivity in lakes.

ACKNOWLEDGMENTS

This publication represents the final report of a project which was supported in part with funds provided by the Office of Water Research and Technology of the United States Department of the Interior as authorized under the Water Resources Research Act of 1964, Public Law 88-379. The work was accomplished by personnel of the Utah Water Research Laboratory in accordance with a research proposal which was submitted to the Office of Water Research and Technology through the Utah Center for Water Resources Research at Utah State University. This University is the institution designated to administer the programs of the Office of Water Research and Technology in Utah.

The authors express gratitude to all others who contributed to the success of this study. In particular, a special thanks to all the Water Quality Laboratory personnel, William Knight, Brock LeBaron, Linda Bagley, Mary Cleave, James Aldrich, Daniel Filip, Darwin Sorensen, Douglas D. Drury, Janet Rogers, Cindy Fulcher, and Rene Komoda; who assisted in the laboratory chemical analysis, and algal identification. Special thanks is also expressed to Gilbert Peterson and the shop personnel who aided in design and construction of the microcosms. Appreciation is also expressed to Dr. Don Sisson, Dr. Rex Hurst, Dr. Leon Huber, and Nancy Auer for their help with the statistical design and formulation and execution of the computer programs.

Sincere thanks are also extended to the Utah Water Research Laboratory, Jay M. Bagley, Director, for providing laboratory equipment and facilities necessary to complete this study and to the capable editorial and secretarial staff for their assistance in preparation and publication of this report.

TABLE OF CONTENTS

	Page
INTRODUCTION	1
Biostimulation and Toxicity in Aquatic Ecosystems	1
Concepts Relating Sediment Effects to Water Quality	2
Objectives of Study	2
LITERATURE REVIEW	5
Microcosm Experiments	5
Nitrogen in Aquatic Ecosystems	5
Sediment nitrogen content	6
Sediment-water nitrogen interchange	6
Mercury in Aquatic Ecosystems	8
Sources of Environmental Mercury	8
Natural mercury sources	8
Mercury waste discharge	8
Mercury utilization	10
Forms and Transformations of Mercury	10
Relation of Microcosm Experiments	13
MATERIALS AND METHODS	15
Experimental Design	15
Microcosms	16
Sediments	16
Collection	16
Distribution and measurements	19
Water	19
Nutrient Media Exchange Protocol	19
Media preparation	19
Connecting the media lines	20
Gas leveling	21
Media exchange	21
Readjusting gas pressures	21
Disconnection	21
For the next day	21
Gas Samples	21
Gas Analysis Methods	21
Gas Analysis Methods	21

TABLE OF CONTENTS (CONTINUED)

	Page
Algae and Bacteriological Procedures	22
Analytical Procedures	22
Nitrogen Fixation	22
Total Mercury Determinations	23
Analytical method	23
Sample pretreatment and storage	24
Sediment samples	24
Standard curves	24
Methylmercury Determinations	24
Mercury Uptake Rates	24
Preparation of Glassware for Mercury Analyses	25
Data Analysis	25
RESULTS: PART I—GENERAL RESPONSES AND OPERATIONS OF THE MICROCOSMS	27
Time of the Experiment	27
Aqueous and Gas Composition	27
Statistical Analysis of Overall Results	27
RESULTS: PART II—GAS ANALYSIS	33
Nitrogen Cycle	33
Carbon and Oxygen Cycles	33
Methods for Study of Gases	34
Results of Gas Analysis and Mass Balances	36
Dark microcosms	36
Horizontally Lighted Microcosms (Both Variable and Nonvariable)	41
Vertically Lighted Microcosms	41
Oxygen Dynamics	41
RESULTS: PART III—THE DYNAMICS OF NITROGEN IN EXPERIMENTAL MICROCOSMS	59
Sediment Nitrogen	59
Assimilation of Nitrogen	60
Nitrogen Fixation	61
Denitrification	61
Nitrification	63
Nitrogen Mass Balance	63
Gas phase	64
Aqueous phase	64
Discussion of Results of Nitrogen Studies	69
Analogy of microcosms to actual lake conditions	69
Ideal nitrogen cycle	69
Nitrogen cycle in microcosms	70
Results of overall mass balance	71

TABLE OF CONTENTS (CONTINUED)

	Page
RESULTS AND DISCUSSION: PART IV—THE FATE OF MERCURY IN EXPERIMENTAL MICROCOSMS	73
Mercury and Sediments	73
Mercury Balance	75
Mercury Uptake Rate	77
Statistical Analysis	77
Discussion of Mercury Results	78
RESULTS: PART V—IRON METABOLISM IN THE MICROCOSMS	81
Aqueous Chemistry of Iron	81
Lighted Microcosms	82
Dark Microcosms	83
Results and Discussion of Iron Distributions in Microcosms	83
DISCUSSION	89
CONCLUSIONS	91
REFERENCES	93
APPENDIXES	97
Appendix A: Analytical Methods	99
Appendix B: Program Micro	103
Appendix C: Analytical Results	115
Appendix D: Mercury Results	141

LIST OF FIGURES

Figure		Page
1	The mercury cycle	9
2	Sources and losses of U.S. mercury in 1968 (Wallace et al., 1971)	11
3	The natural interconversions of mercury	13
4	Variation of methylation rate and sediment concentration in river reach studied (Langley, 1973)	13
5	Microcosm positions in constant temperature room	17
6	Schematic of a microcosm	18
7	Analysis flow sheet (numbers represent ml of sample)	23
8	A simplified and generalized nitrogen cycle in an aquatic ecosystem	34
9	A simplified and general carbon cycle in an aquatic ecosystem showing interactions with oxygen	34
10	Mass balances of gases detected in Microcosm 1 accumulated over period of study	37
11	Mass balances of gases detected in Microcosm 2 accumulated over period of study	38
12	Mass balances of gases detected in Microcosm 3 accumulated over period of study	39
13	Mass balances of gases detected in Microcosm 4 accumulated over period of study	40
14	Mass balances of gases detected in Microcosm 5 accumulated over period of study	42
15	Mass balances of gases detected in Microcosm 6 accumulated over period of study	43
16	Mass balances of gases detected in Microcosm 7 accumulated over period of study	44
17	Mass balances of gases detected in Microcosm 8 accumulated over period of study	45
18	Mass balances of gases detected in Microcosm 13 accumulated over period of study	46
19	Mass balances of gases detected in Microcosm 14 accumulated over period of study	47

LIST OF FIGURES (CONTINUED)

Figure		Page
20	Mass balances of gases detected in Microcosm 15 accumulated over period of study	48
21	Mass balances of gases detected in Microcosm 16 accumulated over period of study	49
22	Mass balances of gases detected in Microcosm 9 accumulated over period of study	50
23	Mass balances of gases detected in Microcosm 10 accumulated over period of study	51
24	Mass balances of gases detected in Microcosm 11 accumulated over period of study	52
25	Mass balances of gases detected in Microcosm 12 accumulated over period of study	53
26	Variation in dissolved oxygen in effluent of horizontal variable lighted microcosms (5: no NO ₃ , no Hg; 6: NO ₃ , no Hg; 7: no NO ₃ , Hg; 8: NO ₃ , Hg)	54
27	Variation in dissolved oxygen in effluents of vertical continuously lighted microcosms (9: no NO ₃ , no Hg; 10: NO ₃ , no Hg; 11: no NO ₃ , Hg; 12: NO ₃ , Hg)	55
28	Variation in dissolved oxygen in effluents of horizontal lighted microcosms (13: no NO ₃ , no Hg; 14: NO ₃ , no Hg; 15: no NO ₃ , Hg; 16: NO ₃ , Hg)	56
29	Example of ethylene production before and after adding nitrogenase substrate (acetylene), Microcosm 15	61
30	Aqueous phase mass balance for dark (anaerobic) Microcosms 1, 2, 3, 4	65
31	Aqueous phase mass balance for horizontal and variable lighted (aerobic) Microcosms 5, 6, 7, and 8	66
32	Aqueous phase mass balance for vertical and continuously lighted (aerobic) Microcosms 9, 10, 11, and 12	67
33	Aqueous phase mass balance for horizontal lighted (aerobic) Microcosms 13, 14, 15, and 16	68
34	Nitrogen cycle in microcosms	69
35	Nitrogen cycle in anaerobic microcosms	70
36	Nitrogen cycle in aerobic microcosms (average values)	70
37	The overall gas phase mass balance does not account for N fixation as measured near the end of the experiment	72
38	Sediment depth vs. mercury in sediment (Microcosms 3 and 4).	74

LIST OF FIGURES (CONTINUED)

Figure		Page
39	Sediment depth vs. mercury in sediment (Microcosms 7 and 8)	74
40	Sediment depth vs. mercury in sediment (Microcosm 11)	74
41	Sediment depth vs. mercury in sediment (Microcosm 15)	74
42	Sediment depth vs. mercury in sediment (Microcosms 12 and 16)	75
43	Mercury uptake rate	77
44	Phase diagram for the solubility of Fe(III) in natural aquatic systems (Stumm and Morgan, 1970)	82
45	Phase diagram for the solubility of Fe(II) in natural aquatic systems (Stumm and Morgan, 1970)	82
46	Percent of total Fe which is free Fe(III), as a function of pH (Theis and Singer, 1974)	82
47	Fe in presence of organic matter and oxygen	83
48	Solubility of Fe ion in equilibrium with solid oxides or hydroxides	83
49	Relationship of total phosphorus and total iron in the light microcosms	85
50	Relationship of particulate phosphorus and iron of the light microcosms	86
51	Relationship between phosphorus and iron which did not exhibit distribution	87

LIST OF TABLES

Table	Page
1	Average organic N distribution in some Wisconsin lake sediments 6
2	Partition coefficients of various sediments for mercuric chloride @ 25°C (Feick et al., 1972) 10
3	Partition coefficients of various sediments for methyl mercuric chloride @ 25°C (Feick et al., 1972) 12
4	Experimental design for microcosm study 15
5	Medium constituents and concentrations 19
6	Data sheet for sampling protocol 20
7	Initial conditions for the microcosms and the sediment 28
8	General observations on the response and operation of the microcosms . . 29
9	Significant effects and interactions on response parameters as affected by the experimental treatments 32
10	Solubility of various biologically important gases as a function of temperature 34
11	Diurnal productivity effects in lighted microcosm 57
12	Reported nitrogen content estimated for various sediment samples . . . 59
13	Averaged vertical distribution of nitrogen in sediments collected from microcosms after 189 days of operation (g N/kg dry weight) 59
14	Estimated nitrogen assimilation rate in microcosms 60
15	Estimated nitrogen fixation rates for microcosms (mg N ₂ /microcosm day) 61
16	Relative nitrogen fixation in microcosms as compared to field measurements 62
17	Denitrification rates in anaerobic microcosms studied in a separate experiment 63
18	Average rates of loss or accumulation in aqueous and gas phases for microcosms 72
19	Mercury in sediments vs. sediment depth (μg Hg/g dry sed.) 73
20	Total mercury in wall scrapings 75

LITERATURE REVIEW

Microcosm Experiments

Previous work performed on sediment-water interactions by staff at the UWRL has been described elsewhere in this report. Those results showed how nutrients cycle and how nutrients were utilized and affected by algae and bacteria. Because most studies of nutrient interactions in sediment-water systems have been very limited, dealing primarily with chemical interactions, there is very little available information applicable to natural ecosystems.

Studies have shown that total available phosphorus in sediments can regulate the algal productivity (Porcella et al., 1970) rather than solely being involved with interstitial waters (Gahler, 1969; Stumm and Morgan, 1970). Models of nutrient uptake and release from sediments have been developed (Porcella et al., 1972) as follows:

Release of nutrients

$$\frac{dC}{dt} = k_2 C_s$$

and accumulation of nutrients in sediments

$$\frac{dC}{dt} = -k_1 C$$

in which C is the concentration in the aqueous phase, C_s is in the sediment phase, t is time, k_1 is the specific accumulation rate (days^{-1}), and k_2 is the specific release rate which is based on areal release ($\text{days}^{-1} \cdot \text{m}^{-2}$). This model is only a conceptual one and more sophisticated mass balance models will be used in the report. Because of the complexity of interactions involved, highly detailed published models will not be used at this time because those models still neglect many of the interactions involved.

Use of microcosms for aquatic system studies has helped greatly in understanding how nutrients are distributed. However, none of these studies has attempted to measure materials balances as comprehensively as the proposed study. Extensive studies on sediments in general, mercury, nitrogen, and phosphorus, as well as other elements in the environment have been performed. Without consideration of the interactive role of the compounds of these elements with sediment-water systems, which en-

compasses chemical-biological and physical phenomena, these studies are of limited theoretical value but will not be of practical value to water quality management strategies. This study has provided practical results as well as data which are of theoretical value in the study of complex and complete ecosystems.

Nitrogen in Aquatic Ecosystems

Nitrogen is an essential element for all living things. Although abundant, forms available to plants are inadequate in parts of the world. In these places, crop production is limited and harvests are often insufficient to meet the needs of the people.

In early history, man learned to apply animal manure to the soil to compensate for nitrogen deficiencies. In modern agriculture the use of chemical fertilizers to meet the demand has replaced manure for filling the nitrogen requirement.

The effects of nitrogen compounds on man depend on its form and concentration. Small amounts of nitrate and nitrite are added to food products with no apparent detrimental effects; larger concentrations have been found to cause health problems in both man and animals. Reduced nitrogen (usually NH_4^+) results in dissolved oxygen problems in streams. Also increased inorganic nitrogen can stimulate the growth of algae in surface waters, interfering with beneficial uses of water as a result of algal scums, odors, turbidity, etc.

With the increased awareness of the problems associated with nitrogen in the environment, there has been growing concern with respect to nitrogen use and control. Consideration of public health aspects (USPHS, 1962) which limits nitrates to 10 mg N/l in drinking water, the effects of NH_4^+ -N on dissolved oxygen in streams as nitrogenous BOD (Stratton and McCarty, 1968; Thomann et al., 1970), and the role of nitrogen in stimulating algal growth, i.e., the problem of eutrophication must be well understood. This study was directed at the eutrophication problem.

Nitrogen fixation and cycling in an aquatic system must be understood so that eutrophication

can be minimized. It is a complex problem dependent upon many physical, chemical, and biological conditions existing in the aquatic environment. Researchers have only recently turned their attention to these complex problems and many questions remain to be answered.

Sediment nitrogen content

Table 1 shows the distribution of organic nitrogen in some Wisconsin lake sediments and also shows the forms of organic nitrogen present. Inorganic forms of nitrogen are only a small percentage of the total nitrogen in lake sediments, and has been shown to be mostly ammonium (Keeney, 1972). Nitrate is not found in sediments because of the reducing environment normally found in sediments. Other nitrogen compounds include various organic forms resulting from biological excretion or degradation which are present as dissolved or solid phase (particulate) nitrogen and these organic forms include amino acids, peptides, and enzymes and structural proteins, other macromolecules such as nucleic acids, and various nitrogenous lipids and carbohydrates.

The amount of nitrogen available in the sediments for recycling varies with each body of water and depends on nitrogen input, nitrogen fixation rates, and the biochemistry of the lake system (Porcella et al., 1972; Brezonik and Lee, 1968; Horne et al., 1972). A variation can also exist within the same body of water when conditions are not constant throughout the lake. The primary form of nitrogen in sediments is organic nitrogen. Austin (1970) found 8.0 g/Kg of total hydrolyzable nitrogen in deep water sediments from Lake Mendota, while shallow water

sediments contained 9.1 g/Kg of total hydrolyzable nitrogen. Sediments from Trout Lake, taken in deep water, contained 25.6 g/Kg of total hydrolyzable nitrogen. Keeney et al. (1970) in a study of nitrogen distribution in thirteen Wisconsin lakes found that the total organic nitrogen ranged from 5.2 g/Kg in oligotrophic, hard water lakes to 32.6 g/Kg in eutrophic, soft water lakes. Data from these lake sediments showed a greater amount of total nitrogen present in eutrophic lakes as compared with oligotrophic lakes. Porcella et al. (1970) found organic nitrogen concentrations ranging from 5.1 g/Kg to 10.5 g/Kg in sediments collected from lakes in California, Oregon, and Wisconsin. Konrad et al. (1970) in a study of nitrogen distribution in a sediment profile found an increasing amount of total nitrogen as the depth into the sediment increased. This was probably due to the depositional environment of the sediments and actual mixing of the sediments. More organic nitrogen was probably associated with the heavier particles than with the lighter, slower settling particles.

Sediment-water nitrogen interchange

Physical factors affecting the exchange of nutrients between sediments and overlying waters are numerous and constantly changing. They include such things as currents, burrowing fauna (worms and invertebrate larvae), movement of fish, escaping gases from sediments, boats, and many other factors (Lee, 1970).

Chemical factors that affect the exchange of nutrients from sediments to overlying waters are not thoroughly understood. One of the primary reasons

Table 1. Average organic N distribution in some Wisconsin lake sediments.^a

Total Organic N, % of Sediment	Acid Hydrolyzable N (% of Total Sediment Organic N)					
	Total	Ammonium	Hexos- amine	Amino Acid	Hydroxy- amino Acid	Unidenti- fied ^b
Northern, soft-water, oligotrophic (6 samples): 1.53	83.1	15.7	4.2	36.3	6.8	43.8
Northern, soft-water, eutrophic (2 samples): 3.26	80.4	15.6	4.2	42.7	7.6	37.5
Southern, hard-water, oligotrophic (1 sample): 0.52	84.4	15.0	3.4	41.3	7.1	40.3
Southern, hard-water, eutrophic (4 samples): 0.80	82.0	19.3	3.3	37.7	6.4	39.7

^aKeeney et al. (1970).

^bUnidentified = 100 - ammonium - hexosamine - amino acid.

for this is the lack of studies to characterize lake sediments. Lee (1970) stated, "Based on the current state of knowledge it must be concluded that natural sediments consist of essentially amorphous materials that remain to be characterized." Bortleson (1968) in studying nitrogen in cores of lake sediments concluded that there is no identifiable relationship between the sediment concentration of nitrogen and the concentration of nitrogen available to algae in the overlying waters. Bremner (1967) has studied the immobilization of nitrogen under varying redox conditions and found immobilization greater under aerobic conditions. Chemical complexation and sorption play key roles in phosphorus recycling but appear unimportant in nitrogen recycling.

Biological factors affecting the recycling of nitrogen in lake sediments probably play the key role. These biological factors can be divided into four areas; nitrification, denitrification, nitrogen fixation, and nitrogen assimilation. In addition to these four areas, biological activity may affect the chemical condition of the water which then directly affects chemical factors involved in the recycling of nitrogen.

Keeney (1972) described nitrification as the biological conversion of N into organic or inorganic compounds from a reduced to a more oxidized state. Alexander (1965) has characterized many algae, bacteria, and fungi that have the ability to oxidize nitrogen compounds, the most common reaction being:



In soils, nitrification is carried on primarily by *Nitrosomonas* ($\text{NH}_4^+ \rightarrow \text{NO}_2^-$) and *Nitrobacter* ($\text{NO}_2^- \rightarrow \text{NO}_3^-$). Alexander (1965) has concluded that optimum conditions for nitrification exist at 30 C and a pH near neutral. If the pH is elevated to a basic pH then accumulation of nitrite will occur. This is due to the fact that *Nitrosomonas* can adapt to the higher pH better than *Nitrobacter*. Porcella et al. (1972) in a study of Indian Creek Reservoir found nitrification-denitrification to be an important process in losses of nitrogen in the reservoir system. Chen et al. (1972) in a study of nitrification in lake sediments found that nitrification rates in calcareous sediments were very high (25 μg NO_3^- -N produced per liter of sediment per 24 hours). These studies show that the role of nitrification becomes important in shallow water sediments which are well mixed.

Denitrification is a biochemical reduction where nitrate or nitrite is converted to a gaseous form of nitrogen, a typical reaction being:

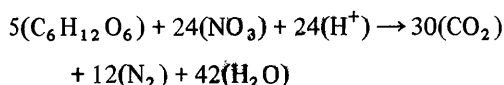

Brezonik and Lee (1968) in a study of Lake Mendota found denitrification to be an important sink. Nitrate concentration in the hypolimnion decreased steadily as the oxygen consumption increased. Approximately 11 percent of the total annual nitrogen input was lost from Lake Mendota due to denitrification. Goering and Dugdale (1966) have shown that denitrification in lakes produces molecular nitrogen rather than nitrous or nitric oxides. Some of the more important bacteria that account for denitrification are *Pseudomonas*, *Achromobacter*, *Bacillus*, and *Micrococcus*. The predominant controlling factors of denitrification have been found to be pH and temperature (Bremner and Shaw, 1958). Chen et al. (1972) found that after two hours, up to 90 percent of the NO_3^- -N disappeared from a sediment sample from Lake Mendota.

Nitrogen fixation is carried on by a wide number of blue-green algae (*Cyanophyceae*) and to a minimal degree in aquatic systems by bacteria. The importance of nitrogen fixation in an aquatic system is still in question (Keeney, 1972) although in Clear Lake it amounts to 43 percent of the annual nitrogen budget (Horne and Goldman, 1972). Goering and Neese (1964) have estimated the nitrogen fixation rate of Lake Mendota to be 0.2 to 1.2 percent of the combined N. Dugdale and Dugdale (1965) showed that the rate of nitrogen fixation may depend upon the concentration of nitrate or ammonium.

Nitrogen assimilation can be defined as the incorporation of nitrogen compounds into the cells of living organisms. The concentration of nitrogen in cells may vary according to the particular species. Kuznetsov (1968) concluded that bacteria are the most important assimilators of nitrogen in some aquatic systems. Dugdale and Goering (1967) showed that nitrogen assimilation peaked in late spring and usually corresponded to levels of low inorganic nitrogen content in the water.

Microcosm studies have been conducted by Mortimer (1941, 1942), Sawyer et al. (1945), and Austin and Lee (1973) to determine the importance of sediments in the nitrogen cycle. Mortimer concluded that the release of inorganic nitrogen under aerobic, quiescent conditions was essentially nil. Sawyer found that under the same conditions (aerobic and quiescent) that 6 percent of the total nitrogen from the sediments was released in 100 days. Austin and Lee (1973), working with the same lake sediments under mixed aerobic conditions, found 50 times the amount of nitrogen released in the same time period. In Austin and Lee's (1973) studies, the complete mixing action caused the sediments to be suspended at all times. Under these conditions a much greater sediment to water contact was maintained allowing a greater volume of sediment to be

subjected to the various processes that would cause the nitrogen to release to the water.

Thus, previous work has shown that the release of nitrogen from lake sediment can play an important role in aquatic productivity. The ability of lake sediments to release nitrogen is dependent upon many interrelated factors including nitrogen metabolism, sediment mixing, and aerobic and anaerobic conditions. These factors and their importance must be evaluated to assess the ecological importance of nitrogen.

Mercury in Aquatic Ecosystems

For centuries, man has used mercury for a variety of purposes without being aware of the potential hazards associated with its use. The discharge of mercury contaminated wastes is now recognized as being environmentally hazardous (Grant, 1971; Wallace et al., 1971). The first tragedies definitely linked to mercury toxicities as a result of discharges of mercury to the environment were in Japan in the late 1950's and early 1960's (Goldwater, 1971). Since then, other outbreaks of mercury poisonings have occurred in Sweden, Canada, Iraq, and the United States (Bakir et al., 1973; Goldwater, 1971; Grant, 1971). These outbreaks have all been linked to the consumption of mercury contaminated food. As a result, Japan, Sweden, Canada, and the United States have become very active in experimental studies tracing the path of mercury through the food chain.

Sources of Environmental Mercury

Natural mercury sources

The natural occurrence of mercury is common and in some soils which overlie deposits of cinnabar (HgS), the surficial level of mercury may be quite high. The highest level in soils in the U.S. was found by the U.S. Geological Survey in Summit County, Utah, and was found to contain 4.6 ppm mercury (Shacklette, 1971).

Swedish investigators have estimated that rain-fall washes mercury from the air causing annual deposition of as much as 0.5 gm/acre (Wallace et al., 1971). Most of the mercury becomes associated with the upper few inches of soil where it can either be revaporized or become bound to the soil. The soil-bound mercury is subject to erosion and eventually can become part of a sediment deposit.

Other natural sources of mercury are ground-water supplies, oil field brines, hot springs, geothermal steam fields, mud pots and active volcanoes (Wallace et al., 1971). Joensuu (1971)

estimates that the natural weathering of soil and rock releases as much as 230 metric tons of mercury annually—most of which ultimately ends up in aquatic sediments. Figure 1 depicts the cycle of mercury throughout the environment (Goldwater, 1971).

Mercury waste discharge

By far the largest manmade discharger of mercury prior to 1968 was the chlor-alkali industry. As a result of legal pressure in 1970, the discharge of mercury by chlor-alkali plants dropped 10-100 times from 287 lb/day to 40 lb/day and many plants were found to emit no more than traces of mercury. Of the other industrial mercury users for electrical and laboratory uses in 1968, 520 tons were recycled and 660 tons were dissipated (Wallace et al., 1971). Portions of the dissipated mercury went to replenishing inventories but much of it was disposed of in landfills, dumps, and incinerators.

Of the total U.S. mercury demand in 1968, 26 percent or 745 tons went to dissipative uses (Wallace et al., 1971). Not all would have the same effect on humans or the ecosystem because of the differing chemical formulations of mercury and dissipative rates. Mercury based paints utilize considerable amounts of mercury but the rate of mercury dissipation to the environment is slow. Dental amalgams apparently have no effect on the patients. Mercury is lost during the manufacture of vinyl-chloride and acetaldehyde and substantial amounts of highly toxic organomercurials are deliberately dispersed in seed grains.

Considerable amounts of mercury are used as slimicides in the pulp and paper industry and as a result these industries have been criticized for many years as a source of mercury pollution. The slimicides are used to treat paper-pulp washwater and during the washing process mercury is transferred to the cellulose fibers and becomes part of the finished paper product.

Municipal and storm sewers are sources of environmental mercury. Applequist et al. (1972) found that the distribution of mercury in sediments of New Haven Harbor, Connecticut, indicate that the primary source of mercury is from municipal sewer outfalls in the harbor.

The leachate of mercury mine tailings contributes mercury to the environment in rather large amounts in the immediate downstream vicinity from the tailing ponds (Peterson, 1973). Wallace et al. (1971) estimate that at a three percent stack loss in the smelting of mercury ore, approximately 31 tons/year of mercury is emitted. As much as 10

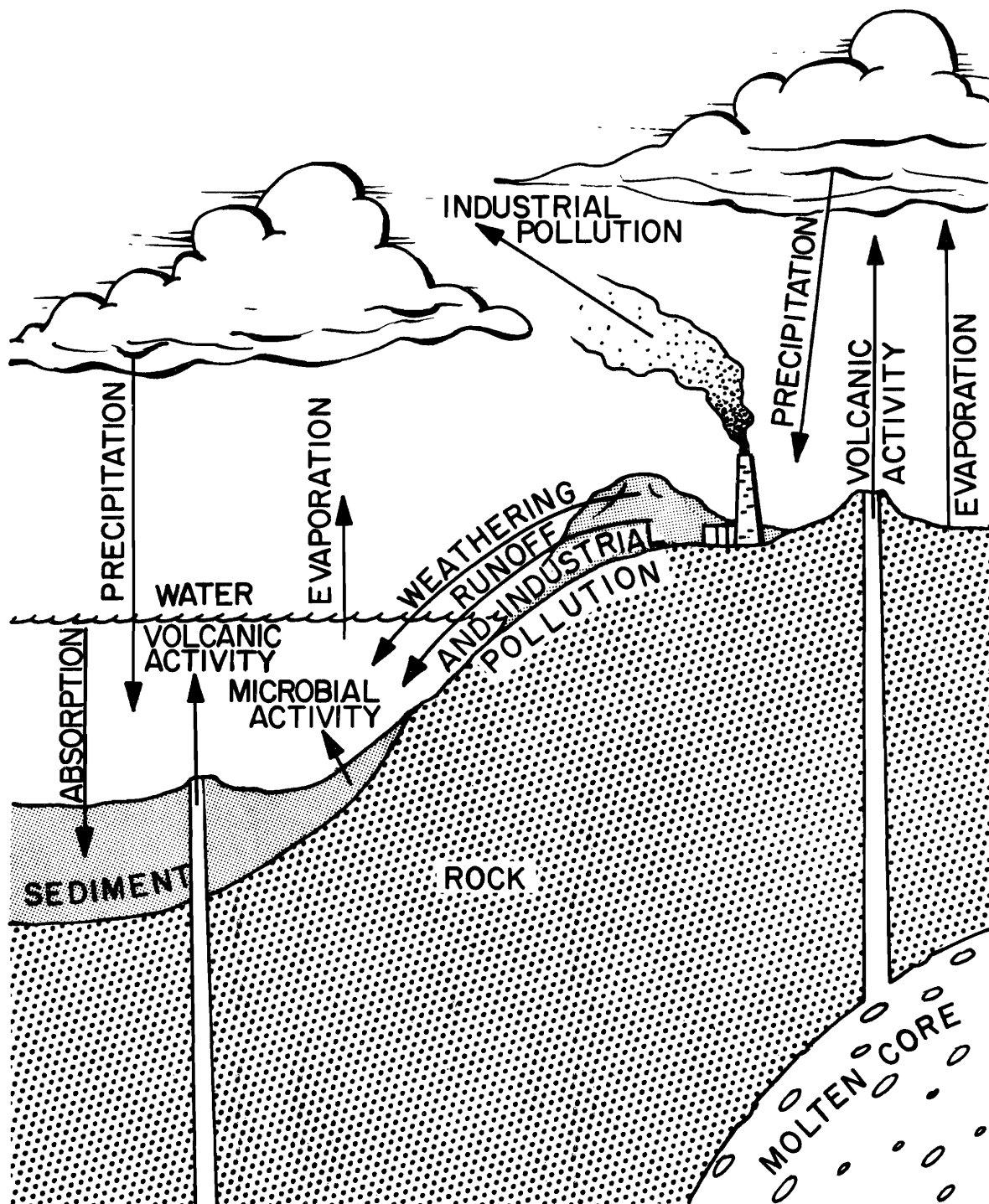

Figure 1. The mercury cycle.

pounds per day of mercury vapor can also be emitted by the smelting of ore for other metals (Anonymous, 1971a).

Substantial amounts of mercury were found to be exhausted through the stacks of municipal incinerators—up to 4500 pounds per year (Anonymous, 1971b). Here, the most probable source of mercury was through the combustion of paper products.

Fossil fuels contain very small amounts of mercury (0.5-3.3 ppm) but the mass consumption of fossil fuels is very large. If a conservative estimate of 1.0 ppm of mercury is applied to the annual worldly coal consumption, then 3000 tons of mercury would be emitted to the atmosphere yearly (Joensuu, 1971). The conservative estimate of 1.0 ppm was based on the range of 0.5 - 3.3 ppm of mercury in U.S. coals (Wallace et al., 1971).

Mercury utilization

The worldwide consumption of mercury has risen by about 1800 flasks (68.4 tons) (a flask contains 76 lb of mercury and is used as the standard measure) per year with the U.S. demand being 1600 flasks (60.8 tons). In 1968, the U.S. consumption comprised 30 percent of the total world production of 257,000 flasks (9766 tons) (Wallace et al., 1971).

In 1968 the U.S. supplies came from four major sources: 36 percent from local mining, 24 percent from government stockpiles, 22 percent from imports, and 18 percent recycle. Of the total mercury consumed, 26 percent is classed as dissipative, which includes consumer products and wastes to the environment (Wallace et al., 1971). A major portion of wastes to the environment ends up in soils or sediments and thereby enters into a very complex cycle. Figure 2 shows the sources and losses of U.S. mercury in 1968.

Forms and Transformations of Mercury

Discharging mercury to the environment involves certain risks and the severity of the risks can only be understood if the forms and interconversions of mercury are studied. The concern over the transformations of mercury arises after one considers that mercury can be mobilized from sediments and other deposits by a change in chemical form.

Jernelöv (1969) listed the major types of mercury discharges and their sources as:

1. Metallic mercury, Hg^0 (chlor-alkali and electrical instrument plants)
2. Inorganic divalent mercury, Hg^{++} (chlor-alkali plants)

3. Phenylmercury, $C_6H_5Hg^+$ (paint, pulp, and paper plants)
4. Methylmercury, CH_3Hg^+ (agriculture)
5. Methoxyethylmercury, $CH_3O(CH_2)_2Hg^+$ (agriculture)

There are four basic reactions that transform mercury from one form to another:

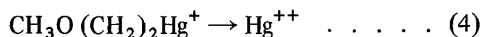
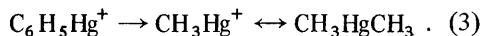
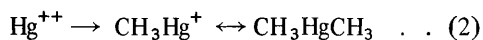

The first reaction progresses readily in an aquatic system in which oxygen is present or in the sediment region where the pH may be less than 7.0. The reducing conditions present in some muds under anaerobic conditions are also capable of reversing the reaction and forming free mercury. Once oxidized, the divalent ion has a very high affinity for organic muds which is evidenced by the very small partition coefficients for different sediments shown in Table 2 (Feick et al., 1972).

Table 2. Partition coefficients of various sediments for mercuric chloride @ 25°C (Feick et al., 1972).

Sediment Description	Partition Coefficient ^a
Fresh Sand	1.3×10^{-3}
Aged Sand	3.7×10^{-2}
Fresh Peat	$< 1.4 \times 10^{-8}$
Aged Peat	2.3×10^{-6}
Clay (Kaolin)	4.9×10^{-1}
Ground Silica	1.5
Clay + Milled Pyrite	8.3×10^{-6}
Clay + 5% ZnS	1.8×10^{-6}
Fresh Peat + 3.5% NaCl	5.0×10^{-6}
Clay + 1% n-dodecyl mercaptan	2.0×10^{-8}

$$^a \text{Partition coefficient } K = \frac{[Hg^{++}]_{H_2O}}{[Hg^{++}]_{SED}}$$

High levels of mercury were found in freshwater fish in Sweden and the first assumption was that the mercury present was either in the inorganic or phenylmercuric form. This was a reasonable assumption since these two forms were known to be discharged by local factories. However, Westöö (1966) determined that the mercury present was

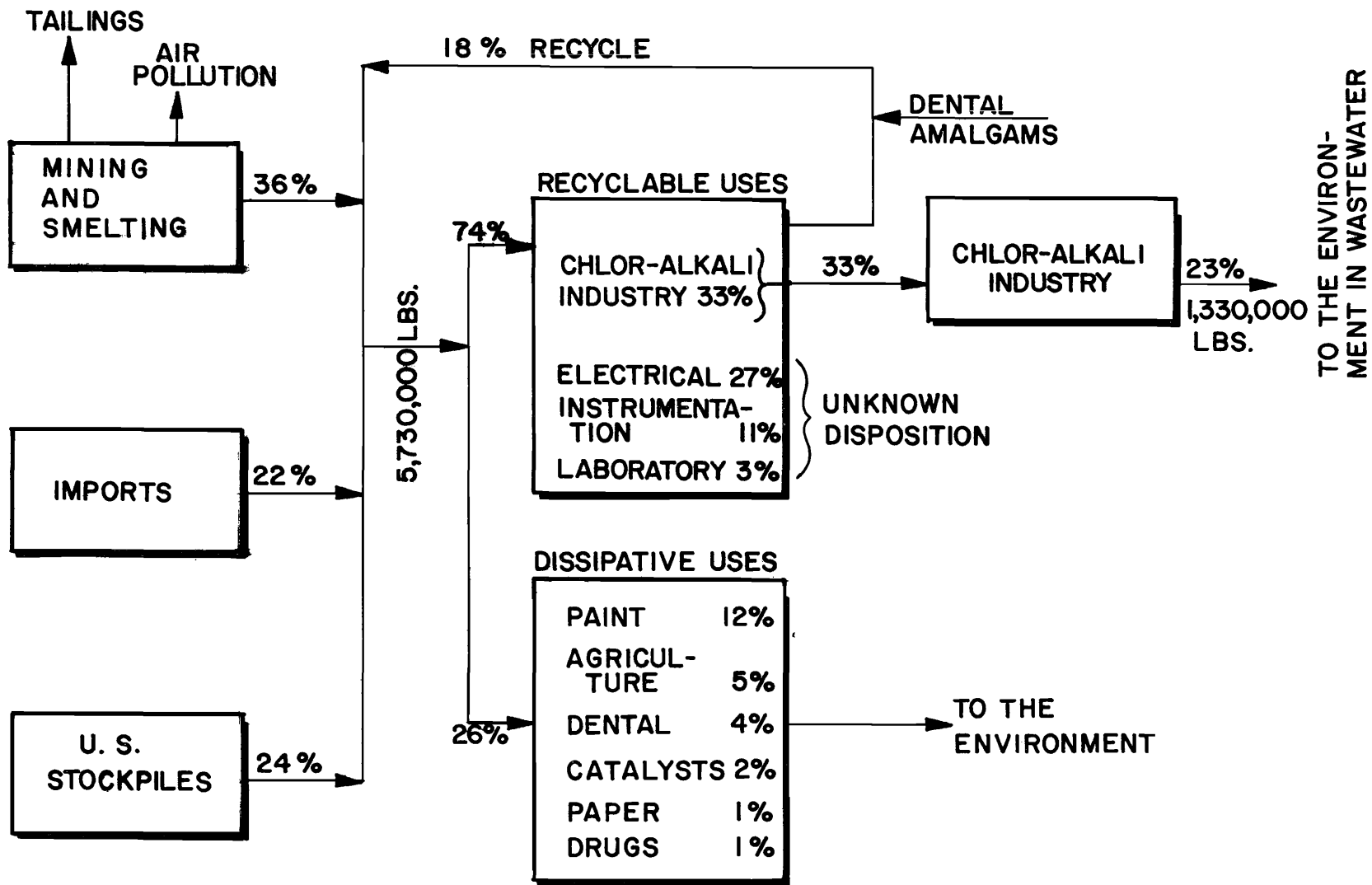

Figure 2. Sources and losses of U.S. mercury in 1968 (Wallace et al., 1971).

almost entirely in the monomethylmercury form. Jensen and Jernelöv (1969) suggested and proved that living organisms could methylate mercury. Through their experiments they were able to show that bacteria could and did transform inorganic and phenyl mercury into mono- and dimethylmercury. These experiments explained the presence of methylmercury in fish when all known sources of mercury were either inorganic or phenylmercurials. Wood and Kennedy (1968) found that certain methanogenic bacteria in sediments could methylate mercury using methylcobalamine (a known methyl donor in biological systems). He also found that methylcobalamine itself, without other enzymes and organisms, was sufficient to cause methylation. In the presence of methylcobalamine, methylation proceeds at a very high rate (Imura et al., 1971). Methylcobalamine has been isolated in mammals in calf liver and in human blood plasma and methanogenic bacteria. The bacteria are ubiquitous in sediments and sewage sludge and contain methylcobalamine in large quantities as an intermediate of methane synthesis (Imura et al., 1971). Jernelöv (1969) tested samples of over 100 rivers and lakes in Sweden and found bacteria capable of methylating mercury in all of them. The methylation of mercury causes concern because ionic mercury that was previously bound to sediments becomes mobile—the monomethyl form is water soluble and the dimethyl form is volatile and vaporizes. Table 3 lists some values for partition coefficients of methylmercury in various sediments.

Table 3. Partition coefficients of various sediments for methyl mercuric chloride @ 25°C (Feick et al., 1972).

Sediment Description	Partition Coefficient ^a
Fresh Peat	6.8 x 10 ⁻⁴
Aged Peat	2.3 x 10 ⁻³
Kaolin Clay	1.2
Clay + 5% ZnS	1.5 x 10 ⁻³
Clay + 1% n-dodecyl mercaptan	8.0 x 10 ⁻⁴
Clay + 5% Milled Pyrite	1.2 x 10 ⁻¹

$$^a\text{Partition coefficient } K = \frac{[\text{Hg}_{\text{Me}}^{++}]_{\text{H}_2\text{O}}}{[\text{Hg}_{\text{Me}}^{++}]_{\text{SED}}}$$

The partition coefficients of methylmercury are 10² to 10⁵ times greater than those for inorganic mercury (Table 2). Therefore, sediments are not nearly as effective a sink for methylmercury as they are for inorganic mercury. Bottom fauna such as plants and burrowing worms also redistribute mercury in sediments but to a lesser extent than

methylation. If the conversion of inorganic to methylmercury is the rate determining step in the natural removal of mercury from sediments, then this process could take from 10-100 years (Jernelöv, 1969). Under anaerobic conditions where the predominant form of mercury may be the sulfide (HgS), methylation was not found to occur. However, methylation could proceed readily in aerobic muds after the sulfides were oxidized to sulfates (Jernelöv, 1969).

Jernelöv (1969) found that phenylmercury could be converted to mono- and dimethylmercury in bottom sediments:

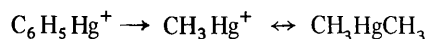

His experiments were difficult to duplicate quantitatively but it was apparent that the transformation followed more than one pathway and that the reactions might be competitive. There are repeated indications that the discharge of phenylmercury has a stronger effect and faster concentration in fish than the discharge of similar quantities of inorganic mercury (Jernelöv, 1969).

The conversion of methoxyethylmercury to inorganic mercury is



also known to occur (Jernelöv, 1969).

A summary of the natural interconversions of mercury is shown in Figure 3. These natural interconversions will be greatly influenced by reaction rates. The rate of mercury methylation is dependent on a number of experimental conditions: temperature, pH, redox potential, microbial activity, mercury concentration, and organic material levels. Langley (1973) found that methylation rates varied from 0.12 to 4.83 nano-gram (ng) Hg/week/cm². Figure 4 shows some of Langley's results of mercury methylation rate versus the concentration of mercury in sediments. He found that methylation of mercury was a maximum at a sediment concentration of 3.8 mg/l of mercury compared to a maximum sediment concentration of 68.1 mg/l. It is hypothesized that above 3.8 mg/l the mercury level may be high enough to exhibit toxic effects on the methanogenic bacteria. The sediments which showed the greatest methylation also showed a much greater number of bacteria than other sediments analyzed. Langley (1973) also found that the dimethylmercury liberated from the sediments varied from 2 to 12 percent of the total methylmercury generated in the sediments. Kolb et al. (1973) showed that dimethylmercury would not remain in the aquatic system very long because of its insolubility in water and tissues.

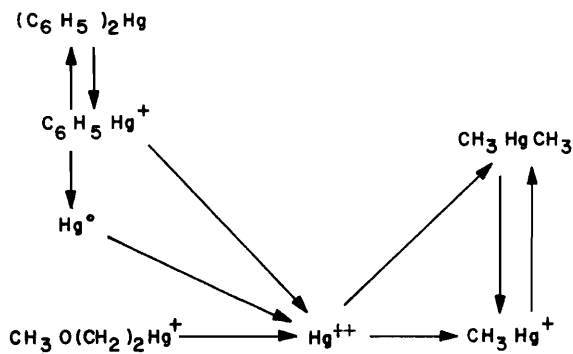

Figure 3. The natural interconversions of mercury.

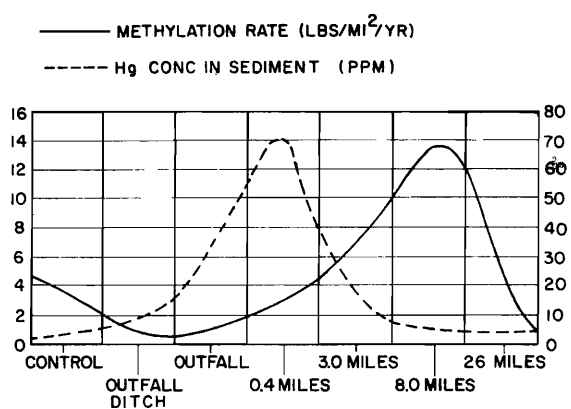

Figure 4. Variation of methylation rate and sediment concentration in river reach studied (Langley, 1973). (Miles x 1.6 = km; lb x 0.454 = kg.)

When Jernelöv (1969) estimated that the natural decontamination by microbial methylation of mercury contaminated sediments could take up to

100 years, he made no mention of bacteria capable of demethylation of mercury. The demethylation process liberated methane and mercuric ion which was available for remethylation by methylating bacteria. Spangler et al. (1973) found that bacteria isolated from environmental samples could degrade methylmercury to inorganic mercury. He analyzed 207 cultures and found that many could degrade methylmercury. Thirty of the isolated cultures could demethylate aerobically, and 21 of the 22 facultative anaerobes could demethylate mercury. Consideration of the demethylating bacteria indicates that Jernelöv's estimate of 100 years for the natural decontamination of mercury containing soils could be increased to more than 100 years.

Jernelöv (1970) conducted other experiments concerning mercury methylation. He found that in an aquatic system without fish or worms or other large animals, the formation and release of methylmercury occurs almost entirely in the upper centimeter of sediment.

Relation of Microcosm Experiments

The problems and the potential problems of mercury discharges to the environment are a very real part of today's modern industrial society. The industrial sources of environmental mercury are fairly well documented but little is known about the fate of mercury once it leaves an outfall. Experiments performed attempted to determine the fate of inorganic mercury in a system that contained water, sediments, and aufwuchs. There were a number of basic questions to be answered: (1) Does inorganic mercury remain in solution or does it adsorb to sediments or organic material comprising the aufwuchs? (2) if it adsorbs to sediments or aufwuchs, how much goes to each? and (3) How deep does mercury penetrate into the sediments?

MATERIALS AND METHODS

Experimental Design

The experimental design for studying exchange of nutrients and metals in sediment water microcosms is listed in Table 4. The arrangement of the experimental units is shown in Figure 5 and consists of sixteen individual microcosms which were studied under varying additions of nutrients, mercury, light and dark, and variable light input. Thus, a 2 x 2 x 4 factorial design replicated in time was utilized to determine what the effects of some of these variables were upon the development of algal populations and the mass balances of metals and specific nutrients (carbon, nitrogen, phosphorus, and iron).

The variations included mercury, nitrogen as nitrate, and light variations. Additions of mercury at environmental levels (50 $\mu\text{g Hg/l}$) were made and analyses for total mercury and the organomercury compounds were made. The effects of the mercury

on the systems and nutrient balances were determined from the factorial-statistical analysis.

The levels of nitrate nitrogen added to the system provided two points in the nitrogen metabolism studies and budgets. The two points were zero and 300 $\mu\text{g N/l}$. The latter is the arbitrarily selected level suggested by Sawyer (1947) as being the lower threshold defining eutrophication.

There were four light conditions: Dark, vertical light, horizontal light, and horizontal variable light. Dark microcosms were utilized as reference points and comparative points in conditions where algal growth does not occur. Vertical light provided a reference point to previous studies performed in the light (Porcella et al., 1970), and horizontal lighting systems were diurnal and designed to purposely duplicate the direction of light penetration into the column of water. Thus, there was a comparison

Table 4. Experimental design for microcosm study.

Time, weeks	Treatments																
	Metals:	Mercury (50 $\mu\text{g Hg}^{++}/\text{l}$)								No Mercury (Zero)							
	Light:	Dark		Vert.		Horiz.		Horiz. Var.		Dark		Vert.		Horiz.		Horiz. Var.	
	Nutrients:	I	II	I	II	I	II	I	II	I	II	I	II	I	II	I	II
0																	
2																	
4																	
6																	
8																	
10																	
12																	
14																	
.																	
.																	
.																	
n																	

I is zero nitrate.
 II is 300 $\mu\text{g/l}$ of nitrate N.

between previous studies (vertical light) with studies performed under more natural conditions. The horizontal variable light had a diurnal cycling with specific microvariations in the lighting level. This light variation during the light cycle of the day was achieved by a timed sequential switch for turning on and off lights in a six bulb bank of lights. Light cycling for the horizontal variable system and the horizontal system was 16 hours of light, 8 hours of dark. Light intensities outside the microcosm at the sediment surface, mid-depth, and water surface are shown in Figure 5.

Light and temperature conditions were maintained as constantly as possible for the period of the study. Temperature was maintained at $25^{\circ}\text{C} \pm 2^{\circ}\text{C}$ in the microcosms and light was determined based on the configuration of the 97 percent spectrum-corrected-to-sunlight, Optima 50 fluorescent bulbs (Duro Test Corporation). These bulbs put out a relatively constant light and only reach 90 percent of initial lumens after 125 days. The microcosm culturing box was placed in an environmental room consisting of two 6 mil plastic walls with a 4 inch dead air space inside a larger room. It was maintained at the appropriate temperature above room temperature to maintain temperatures within the range of $22\text{-}25^{\circ}\text{C}$ in the microcosms themselves. The temperatures increased with incident light so it was not possible to maintain constant temperature for all sets of microcosms.

Microcosms

The microcosms were constructed of lucite cylinders 75 cm high and 15.5 cm in diameter which were completely sealed to the atmosphere (Figure 6). These were filled to a depth of 15 cm with lake sediment (2.25 liters). The cylinder walls around the sediments were painted black on the inside and the outside except for a strip which was taped. These opaque walls prevented growth of photosynthetic microorganisms in the sediments but the strip allowed observation of changes in the sediments as appropriate.

Approximately 9 liters of overlying water filled the microcosms to a level within 2-3 cm of the top seal. Provision for capturing gases released from the sediments was made by the addition of a small-volume, low-displacement, gas-trap. The gas trap leveling bulb contained a 2.5 percent H_2SO_4 solution plus methyl red for color (Andrews et al., 1964).

Each day, 10 percent of the volume of water in each microcosm was removed and replaced with fresh media. The addition of fresh media was made through the lower input port, using media which had been cooled approximately 5° below the ambient tempera-

ture within the microcosm. At the same time, removal of effluent media from the upper port took place. The cooling was done to prevent mixing of fresh media with the media to be removed. Dye studies showed that cooling the input media approximately 5° below the microcosm temperature introduced a thermal gradient into the microcosm. This gradient was sufficient near the bottom to allow removal of the effluent media at the top port without including fresh media. However, within 20-30 minutes the microcosm was completely mixed with no apparent thermal gradient remaining and without a significant net change in temperature. Overall, it was assumed that the small temperature perturbation (initially $\leq 0.5^{\circ}\text{C}$) would have little effect on results.

It was necessary to evaluate the addition of dissolved gases with the fresh media as well as the known dissolved ionic constituents of interest. This was accomplished by calculating the concentrations of dissolved gases according to Henry's Law.

Using water-driven magnetic-mixers, the microcosms were mixed continuously throughout the entire experimental time period (13 intervals) even during the media exchange procedure. The removed samples were utilized for analytical procedures as described below.

Sediments

Collection

Sediments were collected at Hyrum Reservoir, Utah, at approximately the same sampling point as utilized by Drury et al. (1975) in the study of the eutrophication of Hyrum Reservoir. Enough sediments were collected to fill all the microcosms, and to provide sufficient samples for immediate analysis as well as for further analysis. Also, some additional samples were utilized for special studies as indicated below. Sediments were collected in the afternoon using an Ekman dredge and placed in a tank (see Keeney, 1974). Approximately 50 liters were collected. The sediments were mixed as soon as possible (the following morning) by hand in large tanks and then subsampled for the various uses. The sediments were not collected until the experiment was completely ready to begin.

The analyses of fresh sediment included total mercury, total phosphorus, available phosphorus, total nitrogen, soluble inorganic nitrogen, inorganic carbon, organic carbon, and total iron (Appendix A). Water content was measured. Some of these tests were performed at the Soils Laboratory, Utah State University, and others were performed at the Utah Water Research Laboratory.

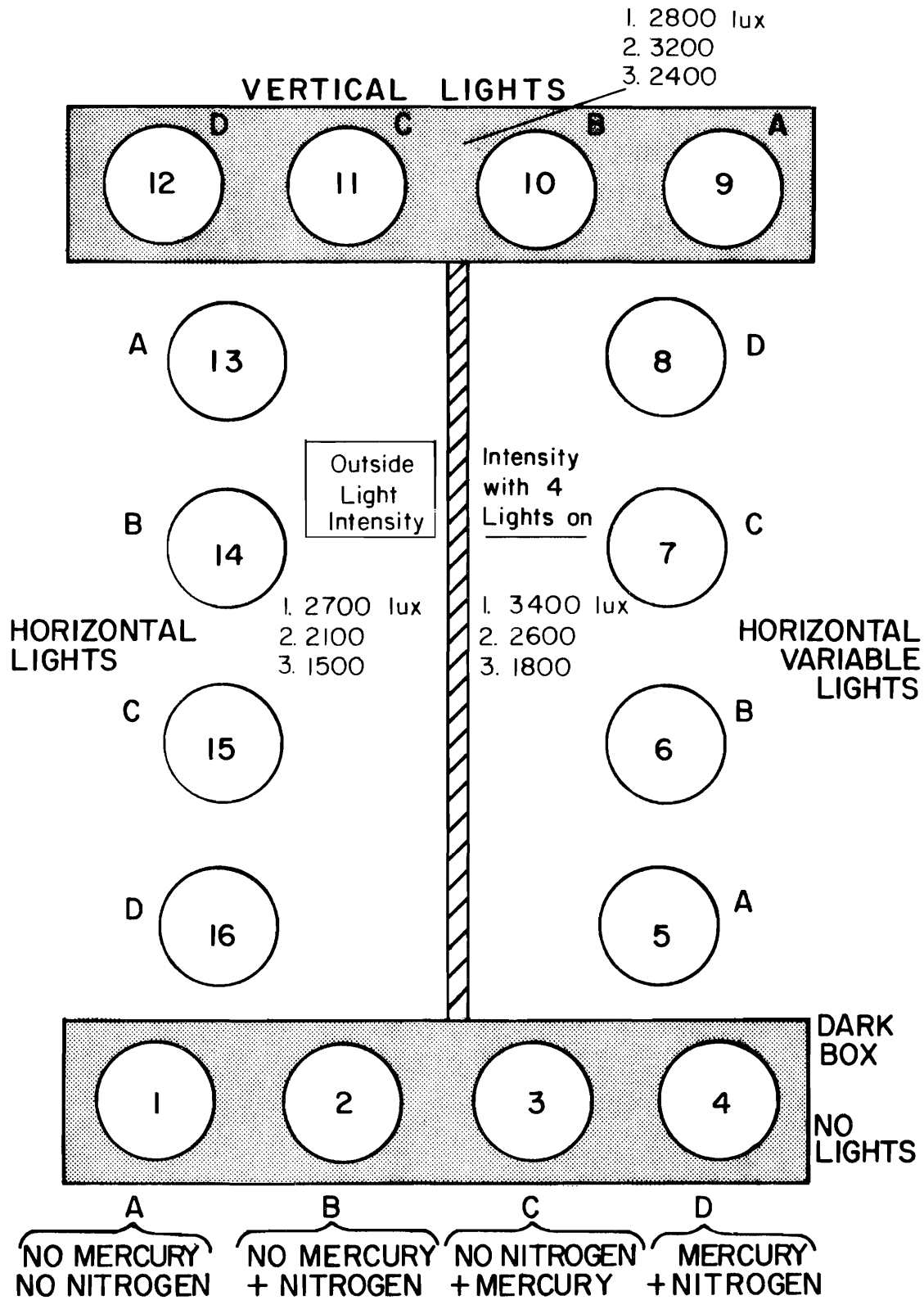

Figure 5. Microcosm positions in constant temperature room. Light intensities were measured at: (1) Water surface, (2) mid water depth, (3) sediment surface.

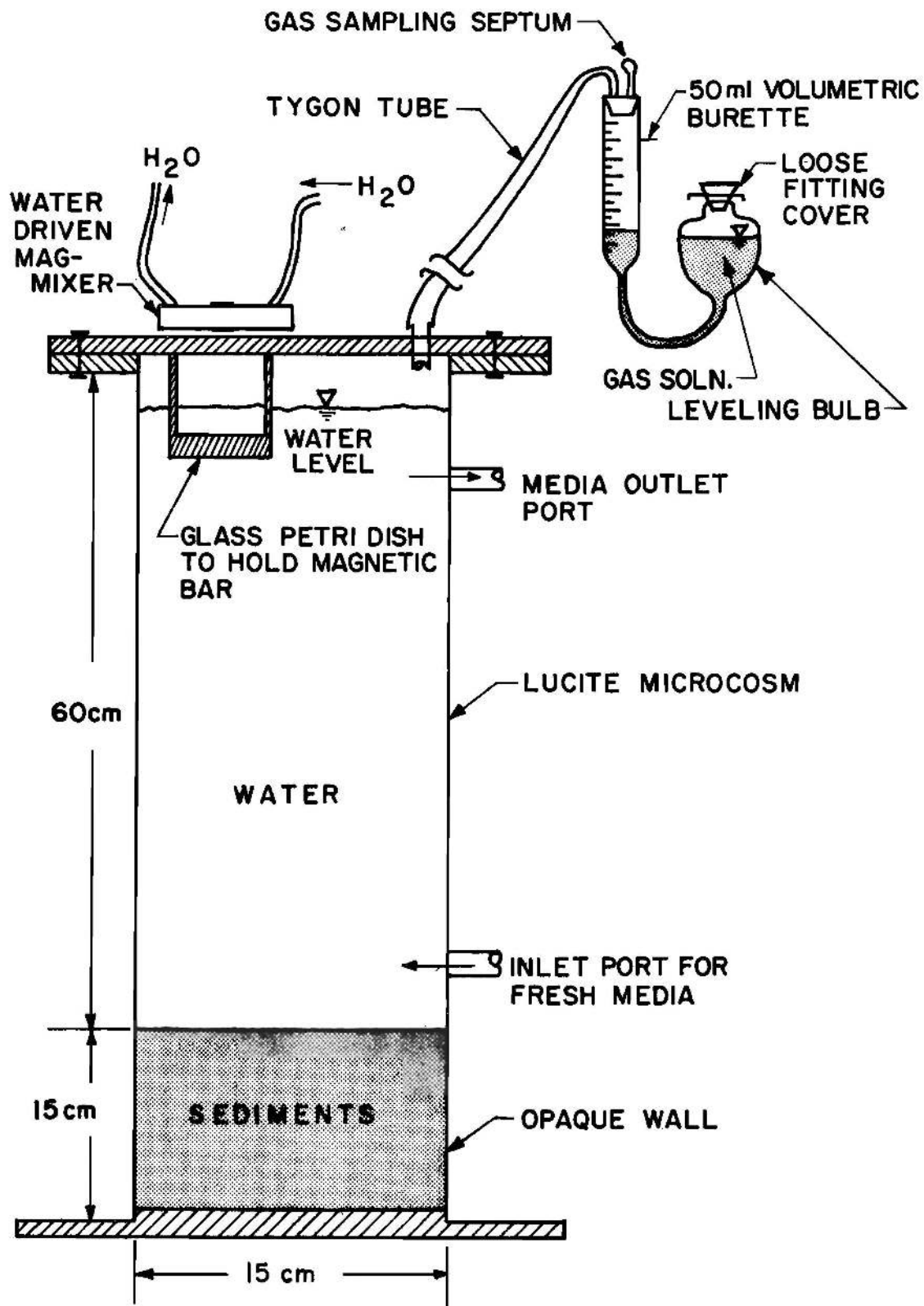

Figure 6. Schematic of a microcosm.

Distribution and measurements

The collected Hyrum sediments were vigorously stirred for 30-40 minutes in a polyethylene container to insure homogeneity of the samples. Then subsamples of approximately 1/4 of the total sediment to be added to the microcosm were added at random from the mixed sample to each microcosm until the mark (2.25 l) was reached. Each subsample was first weighed and then added to a microcosm. The depth of sediment was 15 cm. Samples were also drawn at random for the analysis of the initial conditions.

At the end of the experimental run the microcosms were opened and overlying water removed. Then core samples were taken from the sediments. A 16 cm glass tube (2.5 cm inside diameter) was inserted into the sediments and capped using a rubber stopper. A small piece of glass tubing (5 mm) was inserted adjacent to the glass coring device. As a small positive pressure was being applied to the small glass tube, the coring tube was removed containing the core sample; this process relieved the negative pressure allowing the coring tube and sample to be easily removed. The coring tube and sample was then stoppered on the bottom and placed upright in a freezer and frozen. They were later sectioned for analysis into various lengths of 0-1 cm, 1-3 cm, 3-5 cm, 5-10 cm, and greater than 10 cm. The remaining sediments in the microcosms were thoroughly mixed

and replicate samples collected. These samples were then dried and analyzed to compare with the initial sediment analysis and to estimate any nutrient or metal loss during the experimental run. Sediments before and after the experiments were analyzed for Hg, P, avail P, N, soluble inorganic N, inorganic C, organic C, iron and water content.

Water

Concentrated stock solutions were made up to provide the appropriate nutrients to the deionized water used for the daily replacement of the media. The deionized water was cooled and aerated overnight and then the stock solutions containing nutrients were added just prior to the media exchange. By aerating the deionized water to assumed equilibrium, and recording the temperature and pressure, Henry's Law could be used to calculate the gas solubilities in the deionized water media for mass balance calculations. The stock solutions were based on those described in the Algal Assay Procedures Bioassay (EPA, 1971), i.e. NAAM (Table 5).

Nutrient Media Exchange Protocol

Media preparation

Carefully and completely the appropriate concentrated stock solutions were mixed into the

Table 5. Medium constituents and concentrations.

Stock Sol'n	Compound	Conc. in Stock mg/l	Dil. in Feed D.W.	Element	Final Conc. in Microcosm $\mu\text{g/l}$				
					No Hg		Hg		
					I	II	III	IV	
A.	A ₁ NaNO ₃	1,821	1→1000	N	Yellow Blue ϕ	Green Blue 300	Yellow Red ϕ	Green Red 300	
	A ₂ MgSO ₄ ·7H ₂ O	12,167	10→1000	Mg	12,000	12,000	12,000	12,000	
	A ₃ CaCl ₂ ·2H ₂ O	8,070	10→1000	Ca	22,000	22,000	22,000	22,000	
	A ₄ KCl	7,181	1→1000	K	4,000	4,000	4,000	4,000	
B.	K ₂ HPO ₄	522	1→1000	P	93	93	93	93	
C.	H ₃ BO ₃	186	1→1000	B	33	33	33	33	
	C ₁ { MnCl ₂ ·(MnO ₂ ·4H ₂ O)	264(415)	1→1000	Mn	115	115	115	115	
		ZnCl ₂	33	1→1000	Zn	16	16	16	16
		Na ₂ MoO ₄ ·2H ₂ O	7.3	1→1000	Mo	2.9	2.9	2.9	2.9
	C ₂ { CoCl ₂ (CoCl ₂ ·6H ₂ O)	0.8 (1.5)	1→1000	Co	0.37	0.37	0.37	0.37	
		CuCl ₂ (CuCl ₂ ·2H ₂ O)	0.01 (0.013)	1→1000	Cu	0.005	0.005	0.005	0.005
D.	{ FeCl ₃ (FeCl ₃ ·6H ₂ O)	96 (160)	1→1000	Fe	33	33	33	33	
	Na ₂ EDTA·2H ₂ O	300	1→1000	Na ₂ EDTA·2H ₂ O	300	300	300	300	
E.	NaHCO ₃	15,000	1→1000	C	2,145	2,145	2,145	2,145	
F.	HgCl ₂	67.7	1→1000	Hg	ϕ	ϕ	50	50	

cooled aerated deionized water. The deionized water was aerated overnight and cooled to approximately 5° below the room temperature, i.e., 15-20° C. The containers were color coded to minimize the possibility of a mixup in media additions. The exchange media was made up as follows:

- a. 16l (minus 416 ml to be added with the stock solution) of aerated, cooled deionized water was prepared and the non-variable nutrient solutions added.
- b. 16l divided into four 4l portions (to a calibrated mark on the color coded container) and the variable solutions added. Each of the four 4l portions were made up only as fast as it could be distributed to the appropriate microcosms. The vari-

able solutions were added as follows: Yellow-blue was no nitrate and no mercury; yellow-red was no nitrate and plus mercury; green-blue was plus nitrate and no mercury; green-red was plus nitrate and plus mercury.

The date and time, barometric pressure, room temperature, nutrient media (exchange water) temperature, and any visual observations were recorded (Table 6).

Connecting the media lines

After the made-up nutrient media had been thoroughly mixed, a syphon was established in the influent tube (tygon tubing 1/4" I.D.) of the micro-

Table 6. Data sheet for sampling protocol.

Date
 Year _____
 Month _____
 Day _____
 Time _____

Barometric Pressure _____
 Room Temperature _____
 Input Media Temperature _____

I _____
 II _____
 III _____
 IV _____

Microcosm	Media Vol. Added	Gas Data	Effluent Media Temperature
1			
2			
3			
4			
5			
6			
7			
8			
9			
10			
11			
12			
13			
14			
15			
16			

Additional Comments:

cosm and secured with a pinch clamp. Prior to this tube being connected to the bottom orifice of the appropriate microcosm, the orifice was filled with media to prevent gas bubbles entering the microcosm. The effluent hose was connected to the top orifice and drained into a 1ℓ graduated cylinder to measure the volume exchanged.

Gas leveling

At this time while the lines (influent and effluent) were still clamped, the liquid levels in the gas trap (buret and leveling bulb) were leveled and the water level (bottom of meniscus) of the buret recorded. Adjustments (gas production removal or helium addition) were sometimes necessary to properly level the two water levels and these were recorded (see Table 6).

Media exchange

Then the gas trap was clamped off (this was necessary to prevent suction of the leveling fluid into the microcosm) and the syphon clamp released (influent media). The pinch clamps on the upper and lower orifices were released simultaneously. Approximately 890 ml of effluent was collected in the 1ℓ graduated cylinder. Ideally, 900 ml was exchanged daily; however, a small leeway to balance the gas levels was needed due to a very small pressure difference experienced in the microcosm during the media exchange. Generally the media exchanged was between 890 and 910 ml.

Readjusting gas pressures

The pinch clamps on the upper and lower orifices were released simultaneously to avoid any undue pressure difference within the microcosm. The pinch clamp on the gas trap was removed very carefully. If there was an excessive pressure difference, the solution in the gas trap could be drawn back into the microcosm so extreme care was used at this point. Once the pinch clamp had been removed from the gas trap, the water level in the buret was adjusted to the original level (within < 0.1 ml) before media exchange. The water level in the buret was adjusted by opening the upper orifice pinch clamp to raise the water level in the buret. Opening the pinch clamp on the lower orifice resulted in lowering the water level in the buret.

Disconnection

A pinch clamp was secured to the influent syphon hose and both the inlet and outlet hoses removed. The volume of the effluent collected in the 1 liter graduated cylinder was recorded. If it was an analysis day (every two weeks) the samples were placed in appropriate bottles for analysis later that

day. The next microcosm with the same color code as the exchange solution (nutrient media) was then exchanged using the same procedure as described above.

For the next day

After the media had been properly exchanged, a polypropylene bottle was filled with deionized water to the 16ℓ mark (calibrated for 16ℓ minus 0.416ℓ for nutrient addition) and put in the refrigerator to cool. Aeration was carried out using a diaphragm pump. Any observations, new algal growth, unusual occurrences, etc. were recorded on the data sheets.

Gas Samples

Various methods were tried for the biweekly gas sampling procedure. It was determined that the samples could be easily handled by taking the samples in a 2.5 ml disposable syringe and then sticking the syringe needle into a rubber stopper. The samples could then be taken to the gas chromatograph and analyzed. Although the samples were analyzed immediately, time interval experiments were conducted to determine any possible leak or reaction parameters of the samples with the syringe or rubber stopper. No significant deviations or changes in the gas contents were indicated over a 24 hour time period. Gas samples were collected through a septum located at the top of the buret in the gas trap system (Figure 6). It was assumed that the sample collected from the gas trap was a completely mixed sample; molecular diffusion alone was judged adequate to cause complete mixing in the system.

Gas Analysis Methods

The gas samples were collected by the syringe and rubber stopper technique and analyzed on a Hewlett Packard 5750 research gas chromatograph equipped with a gas sampling valve delivering 0.5 cc of gas to the column for separation and detection. Instrument operating conditions were as follows:

Instrument—H-P 5750 Thermal Conductivity Detector

Columns—6 ft x 1/8 inch o.d. stainless-steel containing 60-80 molecular sieve 5A (O₂, N₂, CH₄)

—6 ft x 1/8 inch o.d. stainless-steel containing 100-120 Porapak S (CO₂, CH₂)

Carrier Gas—Helium

Flow Rates

Carrier Gas—35 ml/min.

Tank Pressure 55 psig.

Temperature

Column—100 - 110°C

Detector—265°C

In jector Port—110°C

Known standards of all the gases detected and air samples were run on a routine basis in conjunction with the samples analyzed from the microcosms. The hydrocarbon gases were also verified using a flame detector on the H-P gas chromatograph. The area under each peak was calculated by the triangulation method and the mole fraction of each gas obtained. Although H₂S could be detected by its odor, the concentration was not high enough to be measured analytically using an ion-specific probe (Orion^R) without a stabilizing solution (see Orion Application Bulletin No. 12, Sulfide; Baumann, 1974).

Algae and Bacteriological Procedures

Freshly collected effluent samples were analyzed for algae and bacteria using microscopy and standard plate counting (PCA) techniques, respectively (APHA, 1971). At the end of the experimental run the walls of the cylinders were scraped using a rubber spatula and the dry weight of the "aufwuchs" collected was measured. No mat of algae growing on the surface of the sediments were obtained; this was different from previous microcosm results (Porcella et al., 1970).

Analytical Procedures

As indicated in the flow chart in Figure 7, there were a large number of analyses performed at the end of each interval (~ 14 days) on the effluent sample taken that day. A daily composite sample of the input media and deionized water was also run with the effluent samples of each interval to check on input concentrations of specific compounds.

Dissolved oxygen (Winkler), pH, temperature, and relative fluorescence of chlorophyll (Turner Fluorometer Manual, Model 110), were measured routinely. Methods utilized for nutrients and other materials are listed in Appendix A.

Nitrogen Fixation

Nitrogen fixation rates were obtained using the acetylene reduction method (Stewart et al., 1967, Hardy et al., 1973). Measurement of nitrogen fixation in effluent samples showed no detectable ethylene production and so it was assumed that any measurable nitrogen fixation was occurring in cells attached to the microcosm walls. Due to the importance of keeping the microcosms sealed at all times, fixation rates were determined only at the end of the study (day 189) when the microcosms were

opened. At that time the microcosms were drained of all but a small amount of nutrient solution. By using the inlet and outlet ports the microcosm was flushed for 30 seconds (flow sufficient for 3 volume exchanges) with gas containing 22 percent oxygen (O₂), 0.04 percent carbon dioxide (CO₂), and balance argon (A₂) (Matheson Gas Products). This was necessary to remove the nitrogen gas (N₂) in the system and to eliminate competition between nitrogen (N₂) and acetylene (CH≡CH) for the nitrogen fixation enzyme (nitrogenase) sites.

Initial samples were taken at time 0 and 30 minutes before acetylene was introduced into the system to determine any residual or natural production of ethylene (CH₂=CH₂). Acetylene was then injected (0.1 atmosphere) into each microcosm and samples were taken from each microcosm at 15 min. intervals for four time periods. The samples were transported to the gas chromatograph (flame ionization, Porapak R) for analysis using the syringe and rubber stopper technique. The ethylene produced was analyzed over this time period and converted to a fixation rate, i.e., mg N₂ [C₂H₂] fixed per microcosm-day. The relationships between the various nitrogen fixation rates were then correlated to the various conditions as described in the experimental design.

Calculations for nitrogen fixation in the lighted microcosms were as follows (no fixation observed in dark microcosms):

C = A • B in which A is the term which gives the production of C₂H₄ per microcosm • day and B is the C₂H₄ to nitrogen conversion factor (Stewart et al., 1967), thus; giving C as the amount of nitrogen fixed per microcosm-day thus:

$$A, \text{ n-moles } C_2H_4/\text{microcosm} \cdot \text{day} = (\text{Instrument Response to } C_2H_4 \text{ standard, n-moles/cm}) \cdot (\text{Sample peak height } (C_2H_4) \text{ per incubation time, cm/min}) \cdot (\text{Illumination time, min/day}) \cdot (\text{Microcosm gas volume during incubation, } \ell/\text{microcosm}) \cdot (\text{Sample of gas injected into the G.C., } \ell)^{-1}$$

Then for an instrument response to a C₂H₄ standard of 0.0017 n-moles C₂H₄/cm, A becomes:

$$\frac{0.0017 \text{ nM } C_2H_4}{\text{cm}} \times \frac{x \text{ cm}}{y \text{ min}} \times \frac{z \text{ min}}{\text{day}} \times \frac{9.4 \ell}{\text{microcosm.}}$$
$$\times \frac{1}{0.0005 \ell} = 31.96 \left(\frac{x \cdot z}{y} \right) \text{ n-moles } C_2H_4/\text{microcosm} \cdot \text{day}$$

Now, since one mole of nitrogen gas (N₂) fixed is equivalent to two moles of nitrogen element (N) and three moles of ethylene (C₂H₄) (Stewart et al., 1967), then for n-moles of nitrogen fixed as N₂

$$B = \frac{1 \text{ n-mole } N_2}{3 \text{ n-mole } C_2H_4} \times \frac{28 \text{ ng } N_2}{1 \text{ n-mole } N_2} \times \frac{\text{mg } N_2}{10^6 \text{ ng } N_2}$$

$$= 9.33 \times 10^{-6} \text{ mg } N_2/\text{n-mole } C_2H_4$$

Thus $C = A \times B$ becomes

$$C = 31.96 \left(\frac{x \cdot z}{y} \right) \text{ n-mole } C_2H_4/\text{microcosm} \cdot 9.66$$

$$\times 10^{-6} \text{ mg } N_2/\text{n-mole } C_2H_4$$

$$C = 2.98 \times 10^{-6} \left(\frac{z \cdot x}{y} \right) \text{ mg } N_2/\text{microcosm} \cdot \text{day}$$

Total Mercury Determinations

Analytical method

Samples for total aqueous mercury determinations, were in general, taken on the day prior to

the regular chemical analysis. This was done because of the large volume of sample required (100 ml).

Total mercury analyses were performed using a Coleman MAS-50 Mercury Analyzer System. The instrument is a flameless atomic absorption spectrometer manufactured by the Perkin Elmer Corporation. The chemistry of the method was developed and thoroughly discussed by Hatch and Ott (1968). The specific procedure is described in the operating manual for the MAS-50 (Coleman Instruments Division, 1972) and is summarized as follows: a 100 ml sample is treated with nitric and sulfuric acids in the presence of potassium permanganate to oxidize all the mercury present to the mercuric ion form (Hg^{++}). After allowing a period of time for the oxidation reaction to take place, the excess permanganate is reduced with hydroxylamine hydrochloride.

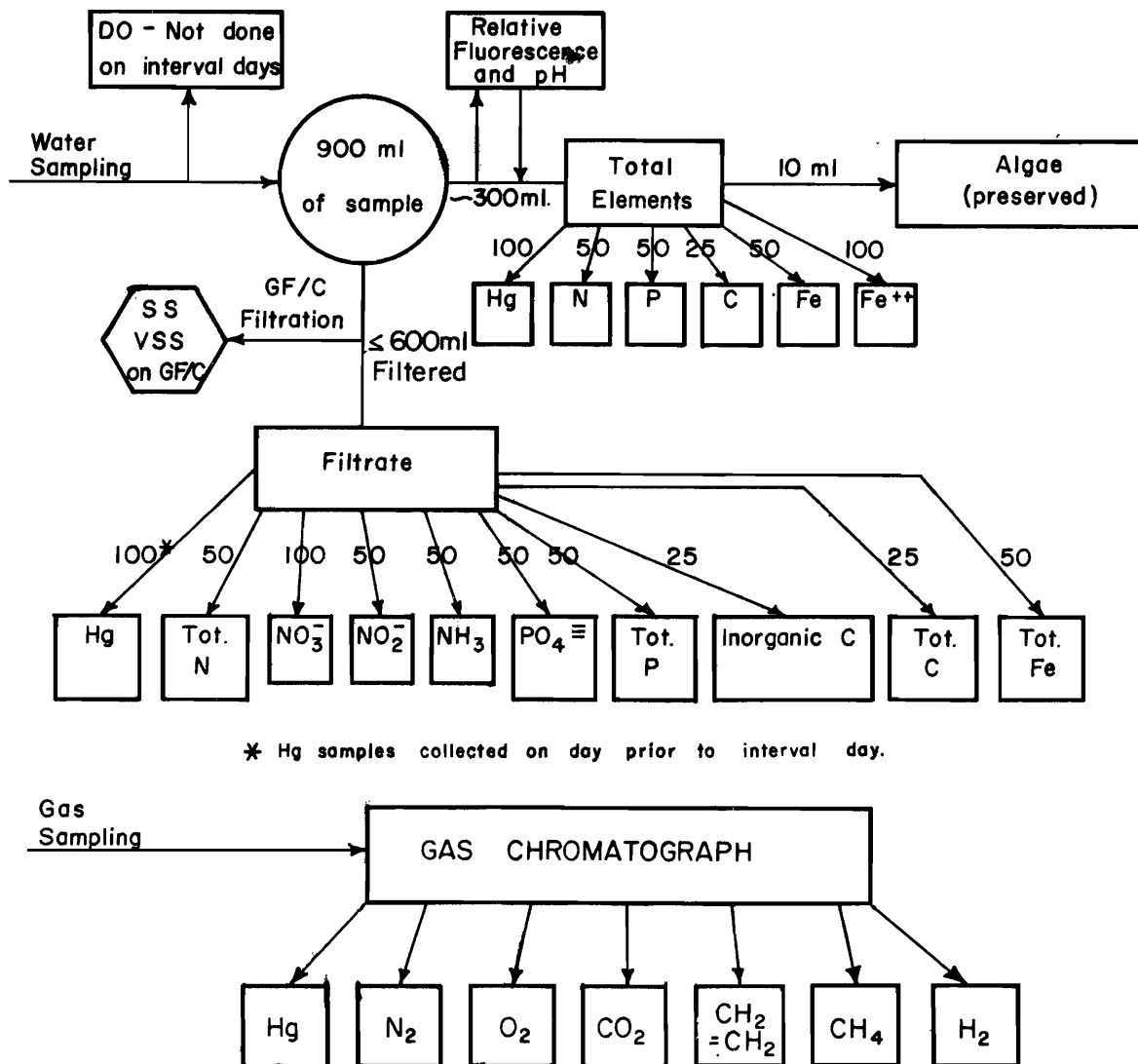

Figure 7. Analysis flow sheet (numbers represent ml of sample).

The mercury is then reduced to metallic mercury with stannous chloride and an aerator is placed in the reduced mercury solution. A pump circulates the air in the closed loop system and the volatilized mercury is carried through the absorption cell. In the atomic form, mercury vapor absorbs the 253.7 nm light emitted from the lamp. A phototube measures the change in the amount of light transmitted. Standard 300 ml BOD bottles were used as aeration vessels to ensure exact volumes into which the free mercury was to be volatilized.

Sample pretreatment and storage

The aqueous samples were taken directly from the microcosms and immediately acidified with nitric acid to pH 1.0 (Coyne and Collins, 1972). BOD bottles were used as sample containers. The appropriate amount of nitric acid was placed in the BOD bottles before the sample was placed in the bottle. Carr and Wikniss (1973) found that mercury could be preserved by storage in glass containers at a pH of 1 or less. Polyethylene containers are unsuitable for storage of waters containing low levels of mercury due to mercury adsorption by the walls of the container (Coyne and Collins, 1972). The samples were refrigerated at 4° C until the analyses could be performed. A sample volume of 100 ml was used and two replicate analyses were performed on each sample.

Sediment samples

The sediment samples were also analyzed for total mercury using the Coleman MAS-50 spectrophotometer. Hatch and Ott (1968) recommended a slight variation from the aqueous mercury procedure for mercury analysis in sediments. One ml aliquots of 30 percent hydrogen peroxide were added to the BOD bottles in addition to the nitric and sulfuric acids and permanganate solution. Depending on estimated mercury concentrations, between 0.05 and 2.0 grams of sediment were weighed and added directly to the BOD bottles. Nitric acid, sulfuric acid, permanganate, and hydrogen peroxide were added as recommended by Hatch and Ott (1968) and the mixture was allowed to stand overnight. The samples were then diluted with distilled water to the 100 ml level and analyzed.

Standard curves

For all total mercury analyses made, a standard curve was prepared covering the range of 0.0 to 50.0 $\mu\text{g/l}$ of mercuric ion (mercuric nitrate). The standard curve was prepared each analysis day from an acidified stock solution of 10,000 mg/l mercuric nitrate. All measurements were read on the lx scale of the Coleman MAS-50.

Methylmercury Determinations

Analyses for monomethylmercury were attempted using a gas chromatography (Hewlett Packard 5750 Research Chromatograph). The conditions of operation are found in Appendix A. The Porapak-S column was found to be unsatisfactory due to the fact that methane (CH_4), ethane (C_2H_6), dimethylmercury ($(\text{CH}_3)_2\text{Hg}$), and monomethylmercury all had the same retention time.

A column (Supelco, Bellefonte, Pennsylvania) recommended in the EPA provisional method for methylmercury determinations was then used (EPA, 1972). See Appendix A for a listing of the operating conditions of this column. Pure monomethylmercuric chloride, for use as a standard, was purchased from K & K Laboratories, Inc., Plainview, New York. Aqueous solutions of pure monomethylmercuric chloride were injected into the gas chromatograph and found to have a retention time of 2.4 minutes. This retention time is in agreement with published data (EPA, 1972). Acidified samples from the microcosms were injected directly to verify the presence or absence of monomethylmercury. The presence of traces of monomethylmercury could only be presumed; a minor peak appeared at the correct time but it could not be ascertained whether this minor peak was due to monomethylmercury or some other organic impurity.

The use of an electron capture detector rather than a flame detector was recommended but the electron capture equipment was not available so the flame detector was used. Westöo (1967, 1968) and Newsome (1971) should be consulted for methylmercury analysis procedures for differing kinds of samples and under various sample forms.

Mercury Uptake Rates

To determine the uptake rate of mercury from solution in the microcosms, microcosm No. 16 was selected and radiolabeled mercuric nitrate (^{203}Hg) was used as a tracer. The labeled mercury has a half-life of 46.6 days and a beta energy of 210 KeV. The stock mercury solution consisted of 1.0 millicurie dissolved in 2 ℓ of dilute nitric acid solution on 28 August 1972.

On 8 June 1973, after 189 days had elapsed from the initiation of the experiment, the pH of 1.0 ℓ of the stock labeled mercury solution was adjusted to the microcosm pH (9.6) and added to microcosm No. 16. The microcosm was immediately stirred and samples were pipetted from the microcosm according to a predetermined time schedule. Two ml samples were pipetted directly into counting vials containing 15 ml of counting cocktail. The counting cocktail was

Aquasol, a xylene-based solution purchased from New England Nuclear Incorporated, Boston, Mass. The sample was added to the cocktail and the mixture shaken to form a clear single-phase liquid. The counting vials were of the standard borosilicate glass variety with a neck diameter of 24 mm.

The beta emission was counted using a liquid scintillation counter—an ISOCAP 300 manufactured by Nuclear Chicago. The tritium-carbon 14 channel (5B) was utilized with a background count of 24-30 counts per minute (CPM). This type of counting is only applicable to counting liquid samples.

To separate liquid and solid phases the samples were centrifuged using a Sorvall Centrifuge for 10 minutes at 20,000 RPM at a force of approximately 49,000 G's. The centrifugal force was determined from the following equation (Bull, 1964):

$$F = 0.0402 r (\text{RPS})^2$$

in which

- F = force in multiples of gravity force
- r = centrifuge radius in cm
- RPS = revolutions per second

Preparation of Glassware for Mercury Analyses

All glassware was washed with hot soapy water and rinsed twice in hot tap water. Then the glassware was rinsed with concentrated nitric acid to remove any residual mercury. Another hot tap water rinse and two rinses with distilled water followed the nitric acid wash. Periodic analyses were performed to check for mercury contamination of the glassware and none was found.

Data Analysis

All measurements were recorded in a permanent log book. Concentrations of specific chemical species were calculated, transferred to IBM cards according to a specified format, and utilized in calculating an elemental balance about the microcosm by computer program. This program is listed in Appendix B. Output from the program was plotted as a function of time and/or analyzed by ANOVA methods (Hurst, 1972) arising from the 2 x 2 x 4 design replicated with time. These analyses will be discussed in the results section.

RESULTS: PART I—GENERAL RESPONSES AND OPERATIONS OF THE MICROCOSMS

At the same time that analytical observations were being collected, visual and other observations concerning the response and operation of the microcosms were being made. The sediment samples were collected on Tuesday, November 28, 1972 about 4:30 PM (MST) at the deepest point (about 20 m deep) in the reservoir and at the sampling site for an ongoing reservoir study (Drury et al., 1975). The sediments were placed in four 5 gallon polyethylene carboys and stored overnight at 6°C (*in situ* sediment temperature). On Wednesday, November 29, 1972, water was decanted directly from the sediments and the sediments transferred to a large polyethylene tub previously cleaned and rinsed with deionized water; the sediments were mixed thoroughly with wooden paddles, subsampled for five replicates for analysis, and distributed to each of the 16 microcosms. The initial conditions in the sediments are listed in Table 4. Then 8 l of media (Table 5) were added to the microcosms and the following day (Thursday, November 30, 1972) the microcosms were filled to the appropriate level and that day was called day 0. Final sealing of the microcosms and operation of the gas measurement began on December 3, 1972, and the initial analysis day was on Thursday, December 13, 1972. Initial conditions were defined according to measurements of the water (Table 5) and sediment phases (Table 7) placed in the microcosms.

After some initial start-up problems during the first two weeks such as with stirrer inoperation, loss of gases and gas volume changes, temperature control, light intensity and duration, and power failures, very few operational problems occurred. Stirrer failure was the most consistent problem. However daily and twice daily maintenance of the microcosms prevented most of those problems after the first week of operation. As can be seen in Table 8 most of the initial problems were over by the first sampling time (December 13). Based on when operational problems were largely eliminated, nutrient and gas balance calculations were begun on December 7, six days prior to the first sampling time (December 13, 1972). Defined initial conditions were assumed to still hold on that date. The study was terminated on June 7, 1973, 189 days after starting but 182 days after beginning nutrient and gas balance measurements.

Time of the Experiment

The study from initial startup day on November 30, 1972, lasted until the last analysis day on June 7, 1973, for a total of 189 days. Because of operational problems the mass balances were calculated beginning with initial conditions on December 7, 1972, and first experimental measurements officially began December 8, 1972. At the end of the experiment in June several measurements were planned which would interfere with gas balance measurements so the last gas measurements were made on June 5, 1973 (187 days from startup). Because the last aqueous measurements were made on June 7, 1973, when the microcosms were dismantled, for mass balance purposes it was assumed that the aqueous nutrient concentrations were the same on June 5. Thus the mass balances were calculated over a 180 day period (December 7, 1972, to June 5, 1973).

Aqueous and Gas Composition

Analysis days were December 13, 27, January 11, 25, February 8, 22, March 8, 21, April 5, 19, May 3, 17, and June 5 (aqueous adjusted from June 7 to June 5) while gas volumetric measurements, temperature, and pressure were measured daily.

Results of the study are shown in Appendixes C and D. Graphs of these data will be discussed in the text where pertinent. Algal identifications of effluent water are listed in Appendix C-4. These data were not particularly relevant as most of the algal growth occurred on the walls of the microcosms. Observation of the wall scrapings at the end of the study showed that *Anabaena* having trichomes containing heterocysts, other blue greens (*Microcystis*, *Oscillatoria*) and diatoms were dominant. Apparently the heterocystous *Anabaena* were responsible for most of the nitrogen fixation.

Statistical Analysis of Overall Results

Although replicate experiments of the treatments in the experimental design were not made

because of the great demand on analytical facilities and space, the experimental design allowed the analysis of variance and some judgments about the interactions between treatments. The analysis of variance was based on the $2(\text{NO}_3\text{-N}) \times 4$ (light conditions) $\times 2$ (Hg^{++}) experimental variations (treatments) and the 13 time intervals where the 22 parameters of nutrients and other chemicals were measured. In addition the calculated nutrient and gas balances for the same time intervals (10 parameters) were utilized in the analysis of variance to provide a total of 32 parameters. These 32 parameters were utilized to estimate effects and interactions between $\text{NO}_3\text{-N}$ (A), light (B), Hg^{++} (C), and time (D)

conditions of the experiment (A = 2, B = 4, C = 2, D = 13). The error mean square was estimated using the total combined conditions (ABCD, 36 degrees of freedom).

All statistical analyses were performed using a factorial design analysis of variance on a Burroughs 6700 computer with a STATPAC (Hurst, 1972) program (STATPAC/FCTCVR). The program calculates the mean square values of the data for the different combinations of variables and then the various F values for the combinations are estimated using the mean square of any combination as the numerator and the mean square of the overall

Table 7. Initial conditions for the microcosms and the sediment.

Microcosm Number	Mass of Wet Sediment, g	Volume of Media Added, l
1	2785	8.90
2	2779	9.15
3	2843	9.14
4	2813	8.97
5	2816	8.91
6	2799	9.10
7	2756	9.11
8	2794	8.95
9	2786	9.00
10	2794	9.10
11	2784	8.98
12	2829	9.00
13	2800	9.00
14	2816	9.14
15	2850	9.25
16	2820	9.09
Mean	2804	9.05
Range	2756-2850	8.90-9.25

Replicate Number	Wet Sediment ^a Percent Water (W/W)	Total ^a Iron $\mu\text{g/g}$	Carbon, g/100 g		Total P ^a $\mu\text{g/g}$	Avail-able P ^a $\mu\text{g/g}$	$\text{NO}_3\text{-N}^{\text{a}}$ $\mu\text{g/g}$	Total ^c Nitrogen $\mu\text{g/g}$
			Organic ^b	Inorganic ^a				
1	70.3	278	2.24	2.52	1100	56	1.2	2280
2	70.3	276	2.25	2.51	1100	55	1.4	2155
3	70.3	278	2.29	2.50	1100	55	1.4	2155
4	70.3	277	2.35	2.50	1100	55	1.4	2240
5	70.2	278	2.30	2.48	1100	55	1.5	2155
Mean	70.3	277.4	2.29	2.50	1100	55.2	1.38	2197
Range	70.2-70.3	276-278	2.24-2.35	2.48-2.52	-	55-56	1.2-1.5	2155-2280
Standard Deviation	< 0.1	0.9	<0.1	< 0.1	-	0.4	0.1	59

^aWeights determined at 103°C.

^bAir dry weight basis.

^cEach replicate represents two analyses; 103°C dry weight basis.

Table 8. General observations on the response and operation of the microcosms.

Date 1972-1973	Elapsed Days	Observation
Nov. 30	0	Filled microcosms with medium; day = 0.
Dec. 3	3	Sealed all microcosms and began collecting gas data.
Dec. 4	4	Increased heating capacity to maintain temperature from 18°C to nearer 24°C in microcosms (M).
Dec. 7	7(0) ^b	Power failure; temperature 13°C; day 0 for calculations.
Dec. 8	8	Bubbles released from sediments in Microcosms 9, 10, 11, 12.
Dec. 9	9	Bubbles released from sediments in Microcosms 9, 10, 11, 12. Lights off due to power overload. Repaired.
Dec. 10	10	Sediment bubbles from Microcosms 9, 10, 11, 12; insect larvae swimming in Microcosm 12.
Dec. 11	11	Sediment bubbles from Microcosms 3, 5, 9, 10, 11, 12. Most released from Microcosm 12.
Dec. 12	12	Sediment bubbles from Microcosms 5, 9, 10, 11, 12. Microcosm effluent temperature about 20°C.
Dec. 13 ^a	13	Sediment bubbles from Microcosms 4, 5, 7, 8, 9, 10, 11, 12, 13, 16.
Dec. 14	14	Sediment bubbles: Much from Microcosms 7, 9-12; few from Microcosm 13. Algae observed on walls of Microcosms 9, 11.
Dec. 15	15	Light failure; affected gas production.
Dec. 16	16	Sediment bubbles: Much from Microcosms 7, 9, 10, 12, 13, 16; few from Microcosms 2, 3, 4. Considerable wall growth of algae in Microcosms 9, 10, 11, 12.
Dec. 17	17	Sediment bubbles Microcosms 2, 3, 4, 5, 7, 9, 10, 11, 12, 13, 16.
Dec. 18	18	Sediment bubbles: 31-50 bubbles, Microcosms 2, 9, 10, 11, 12; 15-25 bubbles, Microcosms 3, 5, 7, 13, 16. Bubbles about 1 cm diameter.
Dec. 19	19	Sediment bubbles (~ 1 cm diameter): 31-70 bubbles, Microcosms 4, 9, 11, 12, 13; 15-30 bubbles, Microcosms 2, 7, 10, 16; 1-15 bubbles Microcosms 1, 15.
Dec. 20	20	Sediment bubbles (~ 1 cm diameter): 40 bubbles Microcosm 11; 16-30 bubbles, Microcosms 2, 4, 6, 7, 9, 10, 12; 1-15 bubbles, Microcosms 1, 3, 5, 13.
Dec. 21	21	Sediment bubbles (~ 1 cm diameter): 31-50 bubbles, Microcosms 9, 11, 12; 16-30 bubbles, Microcosms 1, 2, 3, 10; 1-15 bubbles, Microcosms 4, 6, 7. Green algae now visible in Microcosms 5, 7, 13-16. Effluent temperatures now 23-25°C.
Dec. 22	22	Sediment bubbles (~ 1 cm diameter): 31-46 bubbles, Microcosms 1, 9, 10, 12, 13; 16-30 bubbles, Microcosms 2, 3, 4, 6, 16; 1-15 bubbles, Microcosm 7. Adjusted water volumes in Microcosms 7, 8, 11, 12 by removing 20-40 ml.
Dec. 23	23	Sediment bubbles: 34-35 bubbles, Microcosms 9, 12; 16-26 bubbles, Microcosms 2, 4, 11, 13, 16; 1-15 bubbles, Microcosms 1, 5, 6, 7, 10.
Dec. 24	24	Sediment bubbles: 31-64 bubbles, Microcosms 2, 3, 9, 11, 12; 16-28 bubbles, Microcosms 4, 6, 7, 10, 16; 1-15 bubbles, Microcosms 1, 13. Effluent temperatures 21-24°C. Much wall growth of algae in Microcosms 9 and 10; much gas production also.
Dec. 25	25	Sediment bubbles observed in all microcosms.
Dec. 27 ^a	27	Effluent temperatures 21-25°C; algal growth in Microcosms 5, 6.
Dec. 28	28	Sediment bubbles observed in all microcosms.
Jan. 1	32	Still sediment bubbles observed in all microcosms. Effluent temperatures 21-25°C.
Jan. 2	33	Clumps of blue-green algae observed in effluent from Microcosms 9-12. Green mats observed on sediments from all lighted microcosms.
Jan. 8	39	Wall growth in Microcosm 9 sluffing off; effluent turbid. Effluent temperatures 25-27.5°C.
Jan. 9	40	Walls on Microcosm 9 now clear. Effluent temperature 24-26°C. <i>Ankistrodesmus</i> and <i>Gomphosphoeria</i> dominant.
Jan. 11, ^a 12	42,43	Microcosm 12 starting to peel on walls. Microcosms 2, 3 have H ₂ S smell. Effluent temperatures: Microcosms 1-4: 22°C; Microcosms 5-8: 24°C; Microcosms 9-12: 26°C; Microcosms 13-16: 24.5°C.

Table 8. Continued.

Date, 1972-1973	Elapsed Days	Observation																				
Jan. 14	45	H ₂ S smell in Microcosms 1, 2, 3.																				
Jan. 16	47	H ₂ S smell in Microcosms 1, 2, 3; Microcosm 7 walls starting to peel.																				
Jan. 18	49	H ₂ S smell in Microcosms 1-4; Effluent temperature 24-27°C.																				
Jan. 19	50	H ₂ S smell in Microcosms 1-4; wall growth beginning on Microcosm 9 again.																				
Jan. 23, 25 ^a	54,56	H ₂ S smell in Microcosms 1-4.																				
Jan. 28	59	H ₂ S smell in Microcosms 1-4; Microcosm 10 starting to peel on walls.																				
Jan. 30	61	H ₂ S smell in Microcosms 1-4; Microcosm 16 almost completely peeled.																				
Feb. 6,8 ^a	68,70	H ₂ S smell in Microcosms 1-4; Microcosm 2 usually considerably stronger than others. Microcosm 6 starting to peel.																				
Feb. 14	76	Slight H ₂ S in Microcosms 1, 3, 4; strong Microcosm 2. Effluent temperature 24-26.5°C.																				
Feb. 16	78	Observed ostracods: 50-150/l in Microcosm 16; 20/l in Microcosm 12.																				
Feb. 20, 22 ^a	82,84	Faint H ₂ S in Microcosms 1-4; new growth beginning on walls of Microcosm 16.																				
Feb. 23	85	Faint H ₂ S in Microcosms 1-4; algal mat floating on surface of Microcosm 8.																				
Mar. 2, 4	92,94	Faint H ₂ S in Microcosms 1-4; ostracods in Microcosm 9.																				
Mar. 7	97	Many ostracods noted in Microcosm 6.																				
Mar. 8 ^a	98	Many ostracods noted in Microcosms 6, 9. Some still present in Microcosms 12,16.																				
Mar. 11,21 ^a	101,111	Ostracods present: Microcosm 6 > Microcosm 9 > Microcosm 12 > Microcosm 16. Effluent temperature 24-26°C.																				
Mar. 26,27	116,117	Ostracods still common in Microcosm 9; Microcosm 15 walls starting to peel. Effluent temperature 24-26°C.																				
Apr. 5, ^a 6	126,127	Ostracod population in Microcosm 6 decreasing rapidly; effluent temperature 25-27°C.																				
Apr. 7	128	Microcosm 13 walls beginning to peel.																				
Apr. 10	131	Ostracods still active in Microcosms 6, 9, 16. Also wall growth is peeling in Microcosms 11, 15, 16 (again).																				
Apr. 13	134	Ostracods active in Microcosm 9. Observed large algal mat on wall of Microcosm 9; unique colonial structure.																				
Apr. 18,19 ^a	139,140	Ostracods now in Microcosm 7. Algal mat on wall of Microcosm 9 now about 10 cm in diameter.																				
Apr. 22	143	Microcosm 6 turbid; light yellowish brown color. Effluent temperature 23.5-25.7°C.																				
May 1,3 ^a	152,154	Accidentally sucked approximately 100 ml of acid solution (leveling fluid) into Microcosm 4; pH = 2.5; added NaOH to neutralize.																				
May 9	160	Accidentally added about 50 ml of acid to Microcosm 5 (as in Microcosm 4).																				
May 11,17 ^a	162,168	Have added NaOH to both Microcosms 4 and 5 and kept volume constant; pH now 6.8 and 9.4 for Microcosms 4, 5, respectively. That is typical.																				
May 20	171	Accidentally added acid to Microcosm 4 again; about 27 ml. Neutralized with NaOH. Lost some gas in Microcosm 8. By May 22 pH = 6.4, about typical.																				
May 31	182	All typical; effluent temperature 24.21 to 27.61.																				
June 2	184	Variable lights relay burned out (Microcosms 5-8). Now operated as for Microcosm 13-16.																				
June 6	188	Diurnal study of DO, CO ₂ .																				
June 7, 1973	189(182 ^b)	Study termination; typical conditions:																				
		<table border="1"> <thead> <tr> <th>Microcosm Group</th> <th>Temperature °C</th> <th>DO mg/l</th> <th>pH</th> </tr> </thead> <tbody> <tr> <td>1-4</td> <td>25</td> <td>1.5</td> <td>6.7</td> </tr> <tr> <td>5-8</td> <td>26</td> <td>10.5</td> <td>9.2</td> </tr> <tr> <td>9-12</td> <td>27.5</td> <td>12.7</td> <td>9.5</td> </tr> <tr> <td>13-16</td> <td>26.5</td> <td>12.5</td> <td>9.6</td> </tr> </tbody> </table>	Microcosm Group	Temperature °C	DO mg/l	pH	1-4	25	1.5	6.7	5-8	26	10.5	9.2	9-12	27.5	12.7	9.5	13-16	26.5	12.5	9.6
Microcosm Group	Temperature °C	DO mg/l	pH																			
1-4	25	1.5	6.7																			
5-8	26	10.5	9.2																			
9-12	27.5	12.7	9.5																			
13-16	26.5	12.5	9.6																			

^aSampling analysis.^bDays since December 7, 1972.

combination (ABCD, equals the estimate of the error mean square) as the denominator (Hurst, 1974; Ostle, 1963). The F values were compared for the probability of erroneously rejecting the null hypothesis at the 1 and 5 percent levels for the different degrees of freedom for the different combinations (Hodgman, 1954).

The F values significant at either the 1 or 5 percent level for the 32 different parameters are listed in Table 9 for all the different combinations of the experimental variations. Neither $\text{NO}_3\text{-N}$ nor Hg^{++} variations affected as many variables as light or time. This would be expected for statistical reasons (insufficient degrees of freedom) as well as experimental reasons. Experimentally, light would have a great effect because of the complete darkness variation (no photosynthesis) as contrasted with the lighted conditions (considerable photosynthesis). Also, changes would be expected for the time intervals as populations increased and decreased and as the microcosms matured and approached steady state.

The most sensitive parameters of response were primarily found among the nutrient and gas balance parameters. The total gas volume balance provided the greatest numbers of significant responses to the different combinations appearing at 14 of the 15 total combinations. The concentration of unfiltered total organic carbon (particulate carbon) was the only

highly responsive parameter outside of the nutrient and gas balances. In general gases were the most sensitive parameters. Total gas volume, nitrogen gas, oxygen gas, carbon dioxide gas, and methane gas were all important indicators of interactions.

Thus, microbial activity interact and affect greatly the gas phase system. For example, oxygen and CO_2 would be expected to be greatly affected by $\text{NO}_3\text{-N}$ (stimulation) and Hg^{++} (toxication) concentration as well as light. Nitrogen gas is affected by input processes such as denitrification and output processes (nitrogen fixation). Methane production is due to anaerobic breakdown of organic carbon compounds but rapid utilization of methane gas in overlying, oxygenated waters must also be considered (Rudd et al., 1974).

Several parameters showed no response (nitrate and nitrite) while dissolved organic carbon, dissolved total iron, the mercury balance, filtered orthophosphate P, and unfiltered ferrous iron were relatively insensitive parameters of the effects of the different experimental variations. Some of this insensitivity was caused by analytical imprecision; this was true for the dissolved organic carbon, total iron, and the unfiltered ferrous iron. Further analysis of the parameters and the effects of the treatments will be found in the specific sections on gases, nitrogen, mercury, iron, and phosphorus.

Table 9. Significant effects and interactions on response parameters as affected by the experimental treatments.

Response Parameters	Number of Significant Occurrences	Levels of Significance for Different Treatments (Degrees of Freedom) ^a														
		All Experimental Combinations (207)	NO ₃ -N only (1)	Light only (3)	Hg ⁺⁺ only (1)	NO ₃ -N & Light (3)	NO ₃ -N & Hg ⁺⁺ (3)	Light & Hg ⁺⁺ (3)	NO ₃ -N, Light & Hg ⁺⁺ (3)	Time (12)	NO ₃ -N & Time (12)	Light & Time (36)	Hg ⁺⁺ & Time (12)	NO ₃ -N, Light & Time (36)	NO ₃ -N, Hg ⁺⁺ & Time (12)	Light, Hg ⁺⁺ & Time (36)
Unfiltered Total Phosphorus	7	1		1		1	1	1	1	1						
Unfiltered Total Nitrogen	7	1		1		1	1	1	1	1						
Unfiltered Total Carbon	8	1		1	5	1	1	1	1	1		5				
Unfiltered Total Iron	5			1		1	5	1	1	1						
Unfiltered Total Mercury	5	1	5	1	1	1	1	1	1	1						
Suspended Solids	9	1		1	1	1	1	1	1	1						
Volatile Suspended Solids	9	1		1	1	1	1	1	1	1	5			5		
Unfiltered Ferrous Iron	4			1		5	5	5	1	1						
Unfiltered Inorganic Carbon	8	1		1		1	5	5	1	1		1				
Unfiltered Total Organic Carbon	11	1		1	5	1	1	1	1	1		1		5	5	5
Filtered Orthophosphate-P	4	1		1												
Filtered Total Phosphorus	5	1		1		5				1						
Filtered Nitrite-N	0															
Filtered Nitrate-N	0															
Filtered Ammonium-N	5	1	5	1		5				1						
Filtered Total Nitrogen	6	1		1		5			1	1		1				
Filtered Total Carbon	7	1		1		1	5		1	1		5				
Filtered Inorganic Carbon	7	1		1		1	5		1	1		1				
Filtered Total Organic Carbon	4			1		1			5	1						
Filtered Total Iron	2					1				5						
Filtered Total Mercury	7	1	1	1	1	1	1	1	1	1						
Phosphorus Balance	10	1		1		1	1	1	1	1		1		1		5
Iron Balance	9	1		1	1	1	1	1	1	1				1		
Mercury Balance	4	1		1		1				1						
Nitrogen Balance	12	1	1	1	1	1	1	1	1	1		1			1	1
Carbon Balance	8	1		1	5	1		1	1	1		1				
Total Gas Volume Balance	14	1	1	1	1	1	1	1	1	1		1	1	5	1	1
Nitrogen Gas Weight Balance	12	1	1	1	1	1	1	1	1	1		1			1	1
Oxygen Gas Weight Balance	11	1		1	1	1	1	1	1	1		1			1	1
Carbon Dioxide Gas Weight Balance	11	1	1	1		1	1		1	1		1		1		5
Methane Gas Weight Balance	11	1	1	1	1	1	1		1	1	1	1		1		

^a1, 5 percent levels of significance. Greater than 5 percent are left blank.

RESULTS: PART II—GAS ANALYSIS

Of particular interest in a microcosm study is the accumulation of nitrogen, phosphorus, iron and organic material in the bottom sediments. The accumulation is affected by complex equilibria as the growth, death, and decay of a biological community proceeds. In view of the various studies in the literature, one must conclude that trace metal and nutrient interchanges with sediments as affected by the biota of an aquatic ecosystem have practical significance. The microcosm design allowed information regarding the release and sorption of nutrients which limit the growth of organisms in the aquatic food chain to be obtained.

The microcosm system (Figure 6) was designed to monitor all three phases which exist in a biological community. These phases consist of the sediments, the aqueous and the gaseous phases. It was with considerable interest that the gaseous phase was observed to be an excellent indicator of the biological productivity of the microcosms.

Nitrogen Cycle

Nitrogen (N_2) is the most abundant gas in the atmosphere, making up ≈ 78 percent of the total as compared to ≈ 21 percent for oxygen (O_2) and ≈ 0.03 percent for carbon dioxide (CO_2). Nitrogen gas (N_2) is a rather stable compound and is not an ideal source of the element for most living forms. Combined nitrogen in the form of ammonia, nitrates, organic compounds, etc. which is ultimately derived from this atmospheric source, is the form most used in living organisms. For this reason, the cyclic transformation of nitrogenous compounds is of importance in the total turnover of this element in the biosphere.

An abbreviated nitrogen cycle is illustrated schematically in Figure 8. Many microorganisms can convert organic nitrogen matter (proteins, amino acids, etc.) to ammonia by an oxidative deamination reaction. Ammonia can be utilized or assimilated by many organisms as a sole source of nitrogen. In aerobic environments some of this ammonia is oxidized by nitrifying bacteria (*Nitrosomonas* and *Nitrobacter*) and used as their primary energy source. This process where ammonia is converted ultimately

to nitrate is called nitrification. In anaerobic environments, nitrification does not occur and if ammonia is not assimilated by microorganisms it accumulates. Also in anaerobic environments many types of bacteria have the ability to use nitrates as a source of oxygen. The nitrates undergo transformations (reduction) to gases of nitrogen, primary N_2 and N_2O ; this process is called denitrification. Hence, through denitrification, combined nitrogen is removed from the system by being converted to a near inert gas which escapes into the atmosphere. A limited number of microorganisms (some prokaryotes) have the ability to use molecular nitrogen as a suitable nutrient for growth. This process is called nitrogen fixation. Denitrification and nitrogen fixation function more or less coordinately to maintain a reasonably constant amount of combined nitrogen in the biosphere.

Carbon and Oxygen Cycles

Compounds of carbon and oxygen, like nitrogen, are involved in a series of chemical changes (oxidation and reduction) which permit the continuous cyclic utilization of these elements by plants, animals and microorganisms. The two basic processes which should be considered are photosynthesis and respiration (Figure 9). It is mainly through the process of photosynthesis that carbon dioxide (CO_2 , oxidized form of carbon) is converted to a reduced state (organic compounds) and that molecular oxygen (O_2) is produced by photolytic splitting of water. During the respiration process the organic compounds produced in photosynthesis are oxidized more or less in connection with the reduction of molecular oxygen back to water.

Oxygen and carbon dioxide are two of the most significant chemical substances in natural waters. Although oxygen is one of the most plentiful gases in the atmosphere, it has limited solubility in water. The photosynthetic production of oxygen occurs in the surface layers of a body of water where light is available.

All plants and animals are involved in respiration but the microorganisms appear to be most important in carbon and oxygen dynamics. Aerobic bacteria (pseudomonads, bacilli) as well as fungi

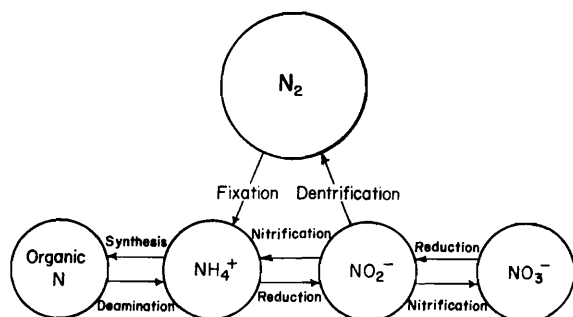

Figure 8. A simplified and generalized nitrogen cycle in an aquatic ecosystem.

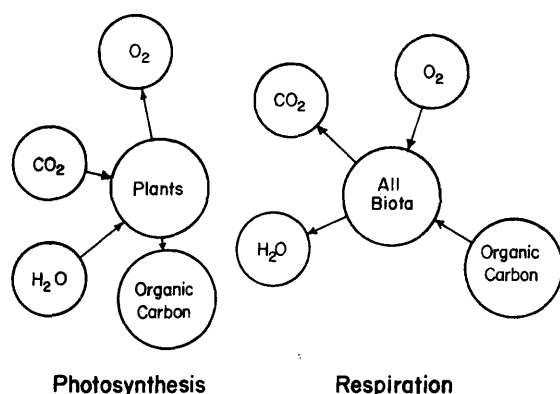

Figure 9. A simplified and general carbon cycle in an aquatic ecosystem showing interactions with oxygen. Organic carbon would include carbohydrates, lipids, protein, nucleic acids, etc., as well as CH_4 , $\text{CH}_2 = \text{CH}_2$, CH_3CH_3 , and other gases.

(actinomycetes) carry out complete oxidations of organic substances from dead cells. This organic matter is decomposed using oxygen dissolved in the water. Once all of the oxygen is consumed, the deep layers become anaerobic. In anaerobic environments, organic compounds are decomposed initially by fermentation, and the organic end-products of fermentation are then oxidized by aerobic respiration.

Methods for Study of Gases

The gas available for metabolic relationships in natural waters are simply the gases that are held or solubilized in the solvent. The volume of gases dissolved in water at any given time is dependent upon (1) the temperature of the water, (2) the partial pressure of the gases in the atmosphere in contact with the water, and (3) the concentration of dissolved salts (salinity) in the water.

The solubility of gases in water increases by lowering the temperature. For example, the solubility of oxygen increases about 100 percent as fresh water cools from 30°C to 0°C (Table 10). (Table 10 considers the total atmosphere above the solution to be only that gas which is being considered. It also considers only the pressure of 760 mm, so for ordinary atmospheric conditions the pressure and gaseous composition must be taken into account.)

At a given temperature the concentration of a saturated solution of a slightly soluble gas that does not unite chemically with the solvent is very nearly proportional to the partial pressure of that gas. That is, Henry's Law is written as

$$P_B = k \times x_B$$

Table 10. Solubility of various biologically important gases as a function of temperature. Data were calculated from Henry's constants (Loomis, 1928). Values are expressed in mg of gas per liter at 760 mm pressure.

Temperature °C	Gas							
	H ₂ S	CH ₄	O ₂ ^a	N ₂	H ₂	CO ₂	He	CH ₂ =CH ₂
0	70.8	39.7	70.4	29.5	1.92	3365	1.73	288.9
10	51.7	29.9	52.0	23.3	1.75	2348	1.77	204.2
20	39.3	23.7	45.0	19.4	1.63	1736	1.78	153.8
30	31.1	19.8	38.4	16.8	1.52	1290	1.80	123.4
40	25.5	17.1	33.8	14.9	1.48	1048	1.84	
50	21.4	15.4	30.4	13.8	1.46	864	1.94	

^aO₂ solubilities under an air atmosphere are approximately 20 percent of these values as oxygen constitutes one fifth of the air atmosphere.

and is obeyed by volatile solutes in ideal dilute solutions. k , known as the Henry-Law constant, depends on the nature of the solvent and the solute and on the units which the vapor pressure (P_B) is expressed. P_B is the vapor pressure of B above a solution of mole fraction x_B . For example, O_2 @ $20^\circ C$ and 760 mm Hg

$$x_B = \frac{P_B}{k}$$

$$k = 3.001 \times 10^7 \text{ (Loomis, 1928, International Critical Tables)}$$

$$x_B = \frac{760 \text{ mm Hg}}{3.001 \times 10^7}$$

$$x_B = 25.32 \times 10^{-6}$$

Now

$$x_B = \frac{n_B}{n_{H_2O} + n_B} \text{ (Expression for mole fraction in water)}$$

Since n_B is very very small in relation to n_{H_2O} , i.e., $n_{H_2O} \gg n_B$, then

$$x_B = \frac{n_B}{n_{H_2O}}$$

or

$$n_B = x_B \cdot n_{H_2O}$$

for $n_{H_2O} = 55.56 \text{ moles/l}$

$$n_B = 25.32 \times 10^{-6} \times 55.56$$

$$n_B = 1.407 \times 10^{-3} \text{ moles } O_2/l$$

Converting to mg of O_2/l

$$n_B = 45.0 \text{ mg } O_2/l$$

The solubility of oxygen also relates to Dalton's Law of partial pressures which states that the total pressure of a mixture of gases is equal to the sum of the partial pressures exerted by each of the component gases. The partial pressure of a gas in a mixture is defined as the pressure the gas would exert if it were alone in the container, i.e.

$$P_{\text{Total}} = P_1 + P_2 + P_3 + \dots$$

or

$$P_{\text{atm}} = P_{O_2} + P_{N_2} + P_{CO_2} + \dots$$

In other words, the solubility of each gas is independent of the other gases in the mixture. It can thus be seen that under atmospheric conditions (≈ 21 percent O_2 , or $P_{O_2} = 0.21$) oxygen is soluble to the extent of 9.45 mg/l (45.0×0.21) at 760 mm Hg pressure and $20^\circ C$.

The third factor which affects the solubility of gases in water is the concentration of dissolved salts. As salinity increases (as solute-solvent attractions become particularly strong) gas solubility decreases. The aqueous media used in the microcosms was assumed to behave like fresh-water and a salinity correction was considered unnecessary.

The rate at which a gas or gases cross the air-water interface and becomes solubilized in the water is dependent upon a number of factors. Mixing, increased wave action, or disturbances at the air-water surface result in greater passage of the gas into solution. The greater the difference in partial pressure between the gas in the atmosphere and the gas dissolved in water, the greater the rate of solution. The process of gas-in-solution is also very dependent upon the biological activities which are taking place in the gaseous and aqueous phases. The direction of gas movement (into the water or out of the water), as well as the rate, is determined by the biological production and uses of the gases in the various phases.

The microcosm was designed with approximately a 450 cc gas volume. As shown in Figure 6, a gas displacement bulb and volumetric buret was used for the gas measurements. Daily the level in the bulb was manipulated to the same level as in the buret and recorded. The barometric pressure was also recorded daily. By bringing the two levels equal, the pressure inside the microcosm was equalized to the outside barometric pressure. It was then possible to calculate the volume increase or decrease and correct it to standard temperature and pressure (STP) for daily production or consumption comparisons.

A water driven magnetic-mixer was employed to insure a completely mixed system. The mixing action also increased the gas movement rate between the gas-water-sediment interfaces.

To obtain a gas mass balance for the system, both the aqueous and gas phases as well as the input and output media were considered. Deionized water was aerated for 24 hours before the nutrients were added in preparation of fresh input media. The aeration step was necessary to air saturate the fresh media. Then by using Henry's and Dalton's Laws in conjunction with the temperature and barometric pressure, the amount of dissolved gases in the media were calculated. This determined the gas added to the system dissolved in the input media. For the gas phase, daily volume measurements were made. From these measurements the volume of gas was corrected to STP. This was done using the following equation:

$$\frac{P_1 V_1}{T_1} = \frac{P_{\text{STP}} V_{\text{STP}}}{T_{\text{STP}}} \quad \text{Charles and Boyle's Law}$$

Solving for V_{STP}

$$V_{STP} = \frac{P_1 V_1 T_{STP}}{T_1 P_{STP}}$$

V_1 = Gas volume of microcosm including buret reading

T_1 = Daily microcosm temperature in °C + 273.15°C

P_1 = Daily pressure in mm Hg - V_{pH_2O} @ T_1

T_{STP} = 273.15 °C

P_{STP} = 760 mm Hg

This expression gives the volume of gases in the gas phase at STP conditions of a microcosm on a particular day. Biweekly, the gas content was measured for N_2 , O_2 , CO_2 , CH_4 and $CH_2=CH_2$ by gas chromatographic methods (see Methods Section). The gas content measurements (in mole fraction) were then incremented for daily change over the interval using linear interpolation. (This was later shown to be a valid assumption by measuring selected microcosms for gas content on a daily basis.) The daily gas content value was used to calculate the milligrams of each gas present in the gas mixture. Assuming "ideal" gas behavior and using the following equation:

$$V_{STP} \text{ ml} \times \frac{\text{mole}}{22,415 \text{ ml}} \times \frac{n_1}{n} \times \frac{\text{mg}}{\text{mole } n_1} = \text{mg of \#1 gas phase}$$

Ideal Gas Behavior
Mole Fraction of Component #1
Molecular Weight of Component #1 in Milligrams

the amount of each gas (in mg) was calculated. With the daily incremented mole fraction value of each gas and using Dalton's and Henry's Laws in conjunction with the barometric pressure and microcosm temperature, the amount of gas dissolved in the aqueous microcosm media was calculated. The effluent media from the microcosm would have the same concentration of dissolved gases as the media in the microcosm and a measured amount was removed daily. Occasionally, it was necessary to add helium to the microcosms to maintain a readable gas level and calculations similar to those already described were used to follow the helium in the gas and aqueous phases. To obtain the mass balance for each gas in each microcosm the following equation was used:

$$\left[\begin{array}{l} \text{Net Change in Gas} \\ \text{Content in a Micro-} \\ \text{cosm During a One} \\ \text{Day Period} \end{array} \right] = \left[\begin{array}{l} \text{Total Gas Content (All} \\ \text{Phases) in Microcosm Before} \\ \text{Media Change on the} \\ \text{Current Day} \end{array} \right]$$

$$- \left[\begin{array}{l} \text{Total Gas Content (All} \\ \text{Phases) in Microcosm} \\ \text{After Media Change on} \\ \text{the Previous Day} \end{array} \right]$$

(See Program Micro, Appendix B, for complete computer program developed to calculate mass balances for the microcosms.)

Results of Gas Analysis and Mass Balances

As was shown in Table 9, all experimental variables (light, nitrate-nitrogen, and mercury) show statistical significance at the 99 percent level for total gas production.

Dark microcosms

Microcosms 1 through 4 were kept in the dark throughout the entire experiment except for a few minutes necessary for the daily exchange of fresh nutrient media. As can be seen from Figures 10, 11, 12, and 13, the total gas volume decreased initially (8 - 40 days). After sediments and organisms had adjusted to the new conditions (muds were initially at $\approx 6^\circ C$ when collected and then mixed thoroughly before being dispensed into the microcosms), gas production began.

After this initial start-up-time Microcosms 1 and 3 had rates of approximately 2.5 cc gas produced/day and Microcosms 2 and 4 had rates of approximately 3.7 cc gas produced/day. By 120 days, all dark microcosms had reached a more-or-less steady state condition. Microcosm 2 (nitrate added) produced the most gas (318.8 ml @ STP) while Microcosm 3 (no nitrate and added mercury) was the least productive (43.3 ml @ STP). Microcosm 4 (added nitrate and mercury) had a total gas production of 180 ml @ STP and Microcosm 1 (no nitrate and no mercury) produced 87.9 ml @ STP. The data show definite stimulation effects of the nitrate and inhibitory effects of the mercury. Microcosm 2 also produced the most nitrogen (N_2) (297.6 mg), methane (CH_4) (259.8 mg) and carbon dioxide (CO_2) (1497.9 mg).

It appears that Microcosm 4 had produced the greatest amount of CO_2 gas but this was caused by an acid spill. At 146 days some acid from the gas trap was sucked into Microcosm 4, this upset the carbonate buffer system increasing CO_2 release to the gas phase. Also the CO_2 saturated the aqueous system and apparently purged N_2 from the aqueous phase.

As these dark microcosms were anaerobic, there was no net oxygen (O_2) production but rather uptake of O_2 by the system. This occurred because reducing conditions existed. The continued loss of oxygen resulted from utilization of the small quantities of oxygen entering the microcosms with the air saturated input nutrient media. All dark microcosms produced some ethylene (C_2H_4) although it was not

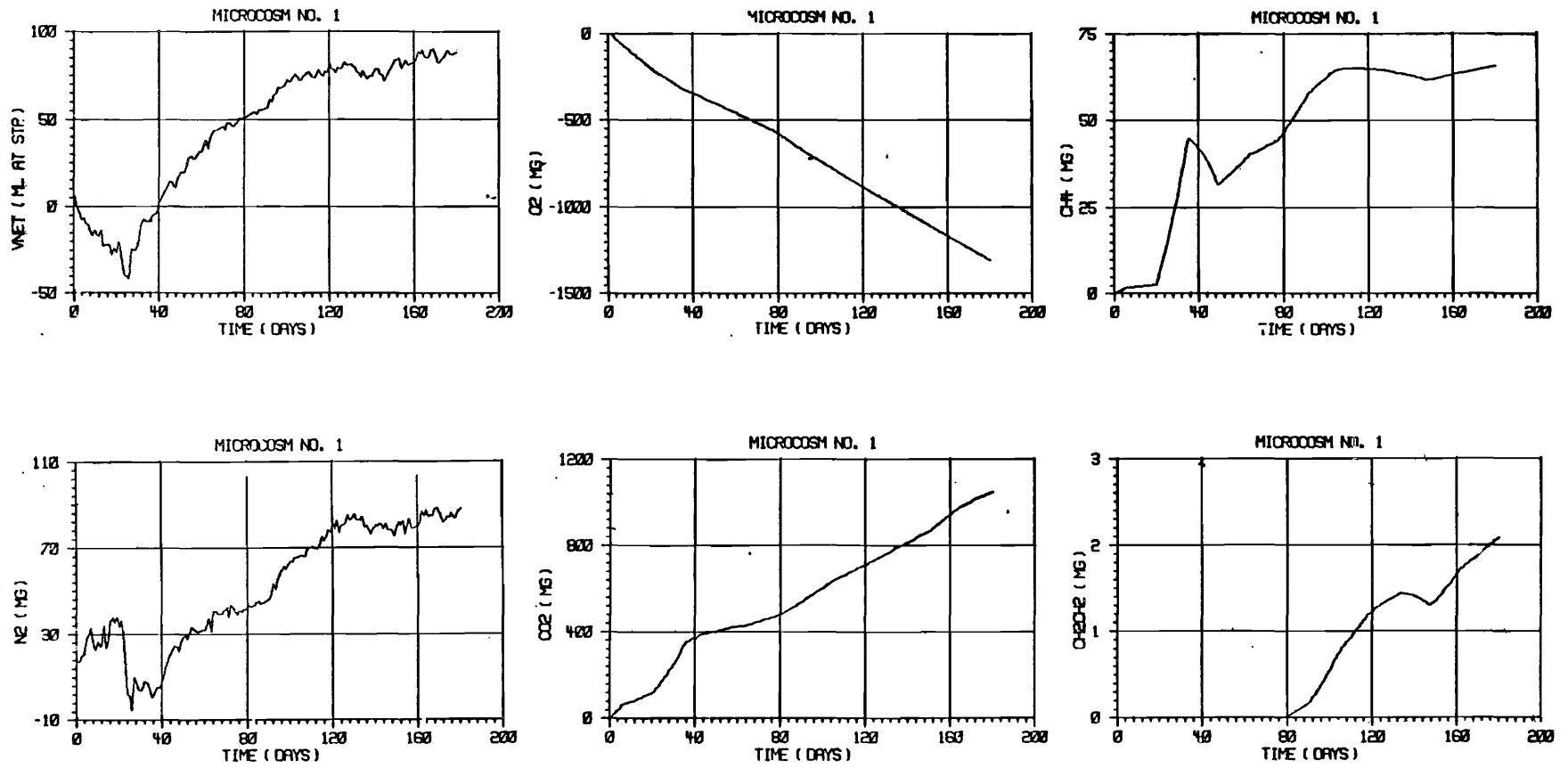

Figure 10. Mass balances of gases detected in Microcosm 1 accumulated over period of study. VNET is total gas production (ml at STP); other gases in mg.

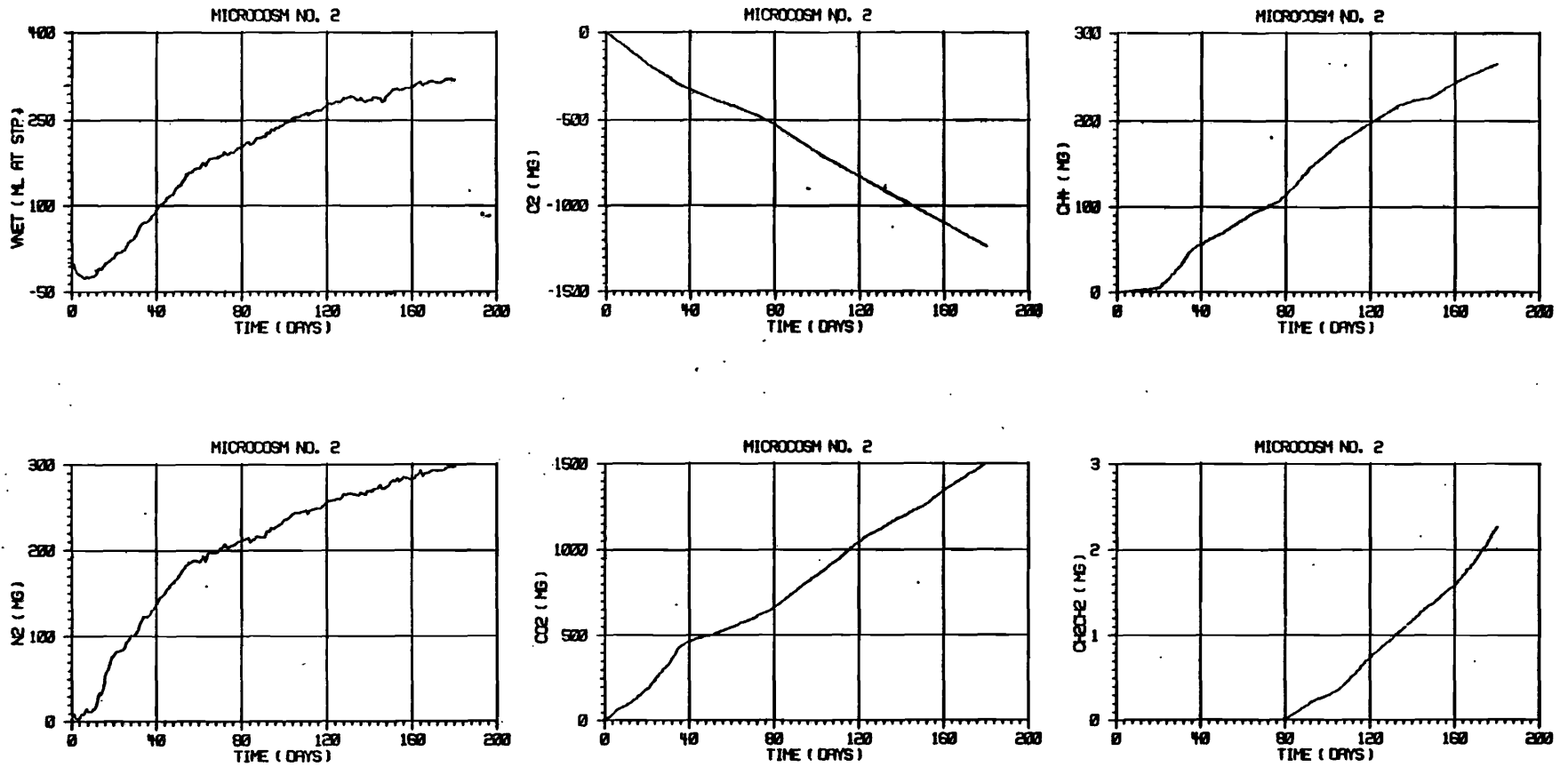

Figure 11. Mass balances of gases detected in Microcosm 2 accumulated over period of study. VNET is total gas production (ml at STP); other gases in mg.

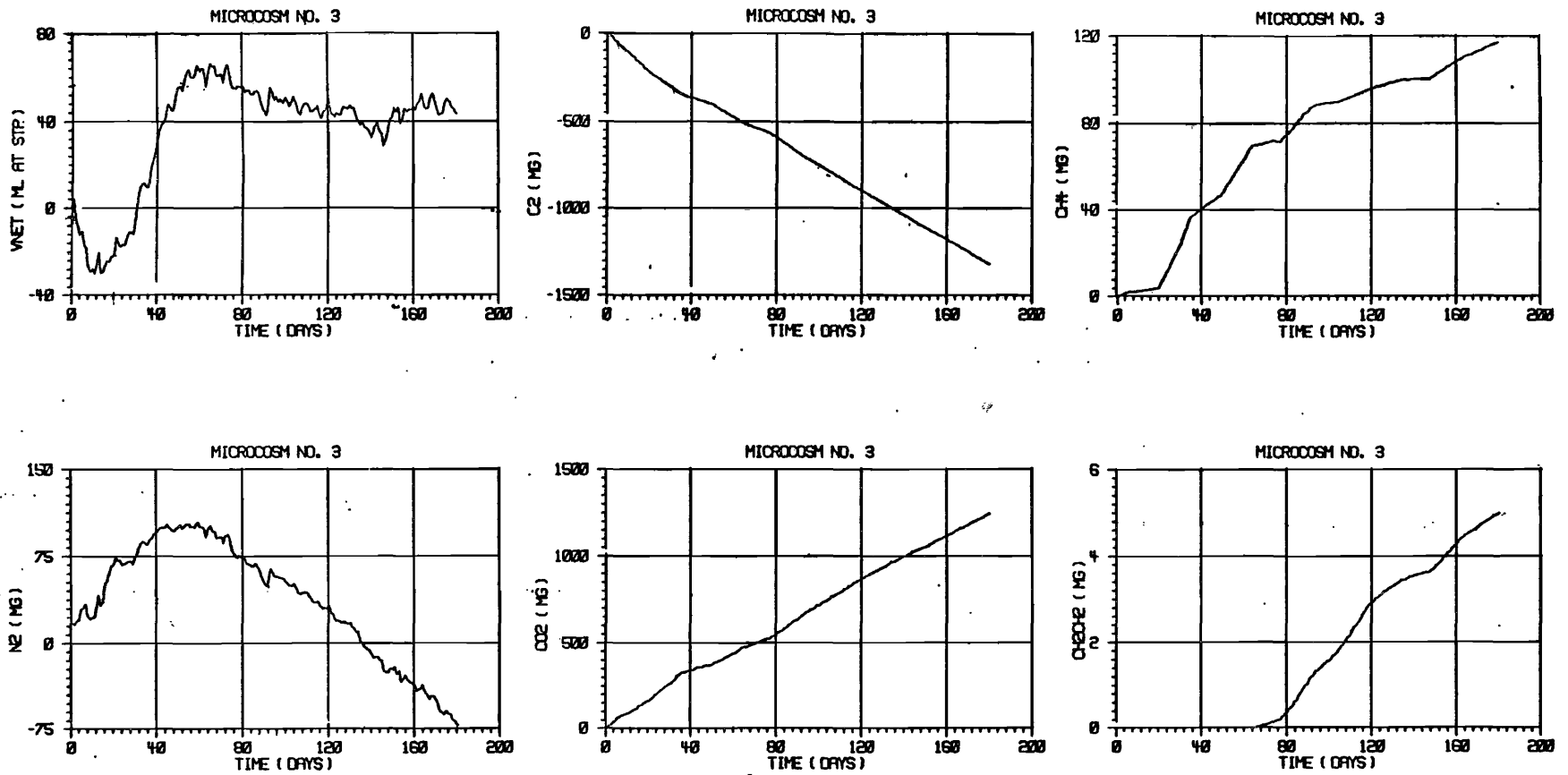

Figure 12. Mass balances of gases detected in Microcosm 3 accumulated over period of study. VNET is total gas production (ml at STP); other gases in mg.

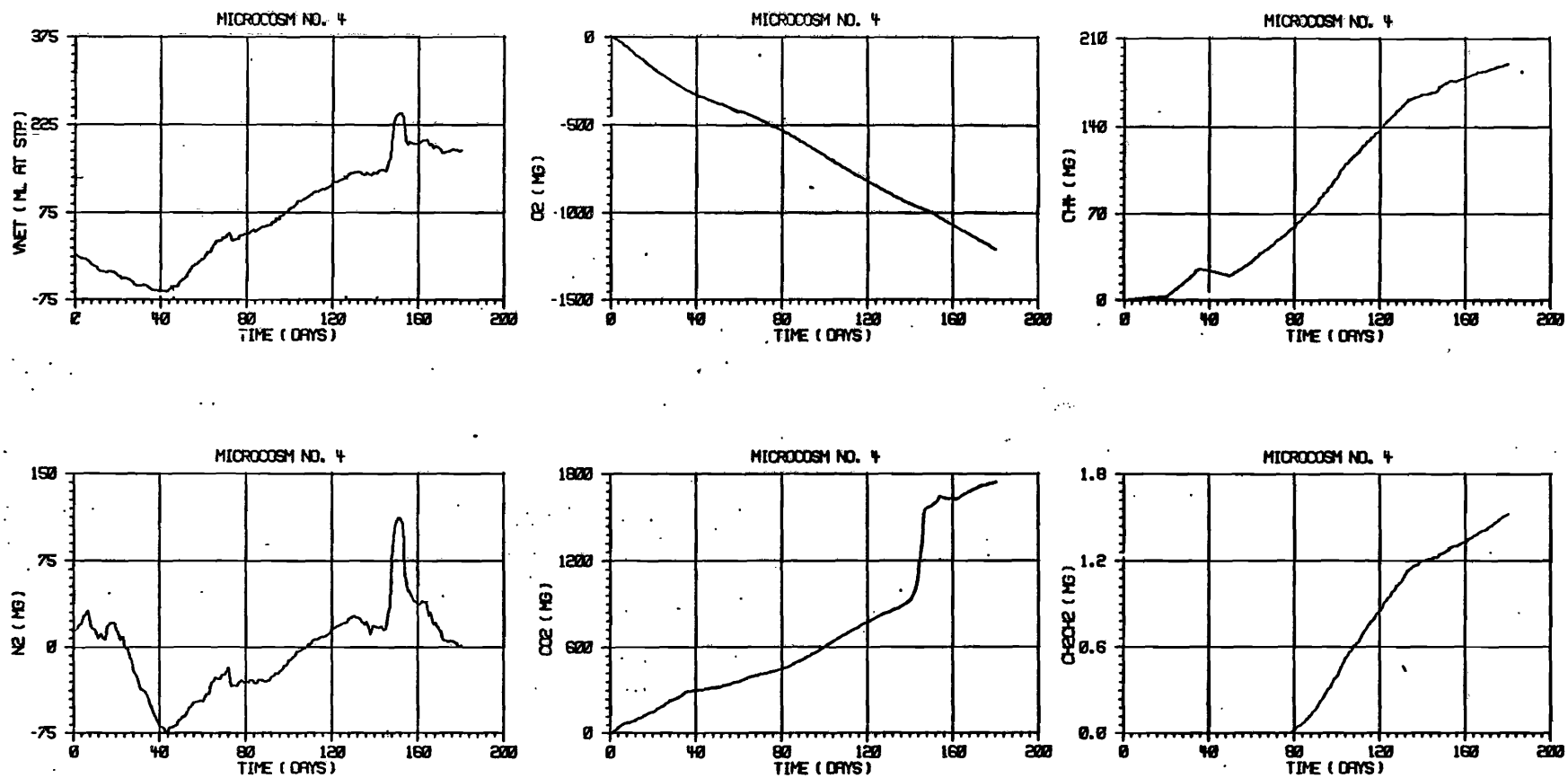

Figure 13. Mass balances of gases detected in Microcosm 4 accumulated over period of study. VNET is total gas production (ml at STP); other gases in mg.

observed until 70 or 80 days into the experiment. Fungi, etc. in soil systems have produced ethylene. The reason ethylene gas was not observed at an earlier date may have been due to utilization, high solubility in water (see Table 10) or an equilibration stage. Apparently ethylene is a better substrate for aquatic bacteria than methane (Flett et al., 1975). Attempts to isolate ethylene in natural sediment water systems are in progress.

Horizontally Lighted Microcosms (Both Variable and Nonvariable)

The variably lighted microcosms (5-8) in general produced less total gas than the nonvariably lighted microcosms (13-16), but both produced more gas than the dark microcosms (Figures 14-21). This was reasonable because as oxygen was the major gas produced, increased light intensity would increase photosynthesis thus showing greater total gas production. There was considerably less methane production in these microcosms, as compared to the dark ones (anaerobic). This was due to 1) methanogenesis perhaps occurring more favorably in the anaerobic microcosms, and/or 2) bacterial utilization of methane in aerobic overlying waters in the lighted microcosms (Rudd et al., 1974). The effects of nitrate and mercury did not appear to have the same types of effects in the horizontal light microcosms as the dark microcosms. After 14 days, the horizontal light microcosms had a high nitrogen gas production rate (i.e. 10 mg N₂/day over a 14 day period) and then leveled off or declined (Microcosms 5, 6, 14).

Carbon dioxide for the first 50 days was being used up (photosynthesis) or dispelled from the system. As the experiment proceeded, the pH increased in the light microcosms. This was the result of CO₂ from the alkalinity system being used by growing algae (Goldman et al., 1972). As the algae reached a maximum growth in proceeding to steady state, some began to die and decay. Thus CO₂ came back into the system by microbial degradation of the organic matter. Also during this first 50 day period, methane was actively produced. This process could result from anaerobic bacterial reduction of CO₂ or more likely from methanogenic fermentation of partially reduced forms of organic carbon compounds in the sediments.

Small amounts of ethylene were also detected in Microcosms 5, 6, 8, 13, 15, 16, probably resulting from sediment fermentation processes (fungi?).

Vertically Lighted Microcosms

These microcosms (9, 10, 11, 12) had the greatest total gas production of the four different lighting combinations (Figures 22, 23, 24, 25). The

total gas production was considerable due to the oxygen production by photosynthesis. The vertical light microcosms received the most light and with heavy algal mats adhering to the sides of the microcosms the vertical light provided a continuous and significant source of energy for photosynthetic metabolism.

For the first 50 days carbon dioxide was being used up at the rate of 0.4 mg CO₂/microcosm-day. At this point, carbon dioxide was produced at a rate of 0.9 mg CO₂ (gas)/microcosm-day for 14 days and then leveled off to a rate of \approx 0.2 mg CO₂ (gas)/microcosm day. This is very similar to the data observed in the horizontal light microcosms. Methane was actively produced in the first 50 days, and then leveled off, following the same general pattern as observed in the horizontal light microcosms. It should be noted that methane production in the vertical light microcosms was second only to the dark microcosms.

Oxygen Dynamics

Weekly measurements of dissolved oxygen (DO) in the effluents showed very low values for the dark microcosms (0.5-1.0 mg/l) and quite high values for the lighted microcosms (10-20 mg/l); under saturation conditions in the temperature range that the microcosms remained within (20-25° C), DO should have been between 7.8-7.1 mg/l. Thus, oxygen was utilized essentially completely in the dark microcosms undoubtedly through benthic demand and even with a daily input of about 7.8 mg DO (0.9 l/day * 8.7 mg/l DO in influent). Thus, benthic oxygen demand was \geq 336 mg/m²·day (31.2 mg/ft²·day) in the dark microcosms. This is the lower limit for the rate of oxygen uptake by river sediments reported by Fillos and Molof (1972).

In the lighted microcosms photosynthesis was sufficient in most cases to create super saturated conditions throughout the study (Figures 26, 27, and 28). Relative fluorescence which is a measure of *in vivo* chlorophyll remained less than 5 units for all microcosms except 6 and 9; values are shown in Figures 26 and 27 for those two microcosms and may be assumed to represent planktonic algae or algal cells and debris from wall growth which was removed in the effluent. Generally, the DO was relatively constant throughout the study except for initial periods of high photosynthesis, then a decrease, and then a period when apparent steady state oxygen production occurred. One notable exception was observed in Microcosm 6. This microcosm had an initial increase in DO as an essentially planktonic population of algae developed. The succeeding development of a great population of ostracods had a significant clearing effect on the algal community in the microcosm as the zooplankton consumed the algae. Over a period

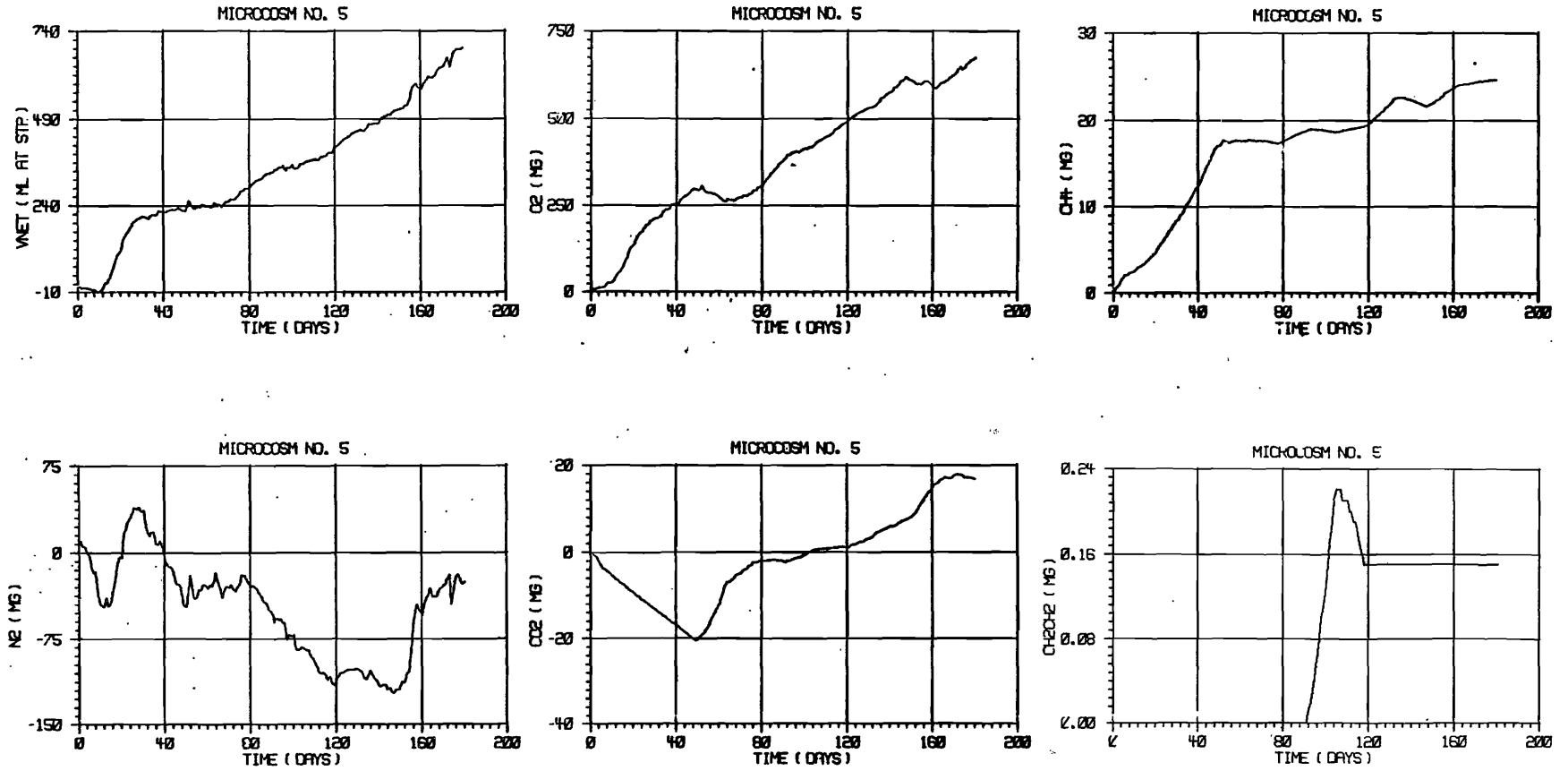

Figure 14. Mass balances of gases detected in Microcosm 5 accumulated over period of study. VNET is total gas production (ml at STP); other gases in mg.

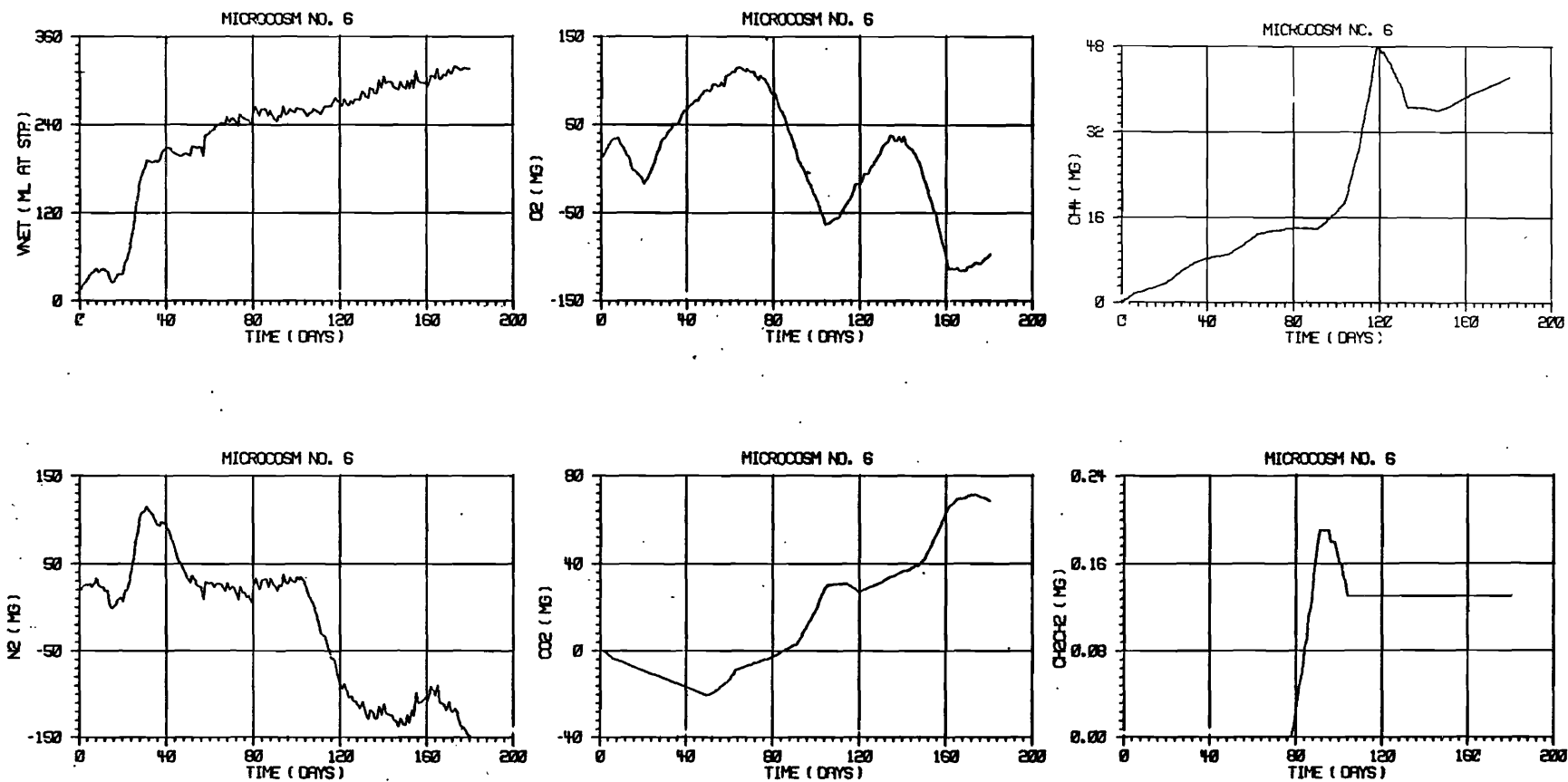

Figure 15. Mass balances of gases detected in Microcosm 6 accumulated over period of study. VNET is total gas production (ml at STP); other gases in mg.

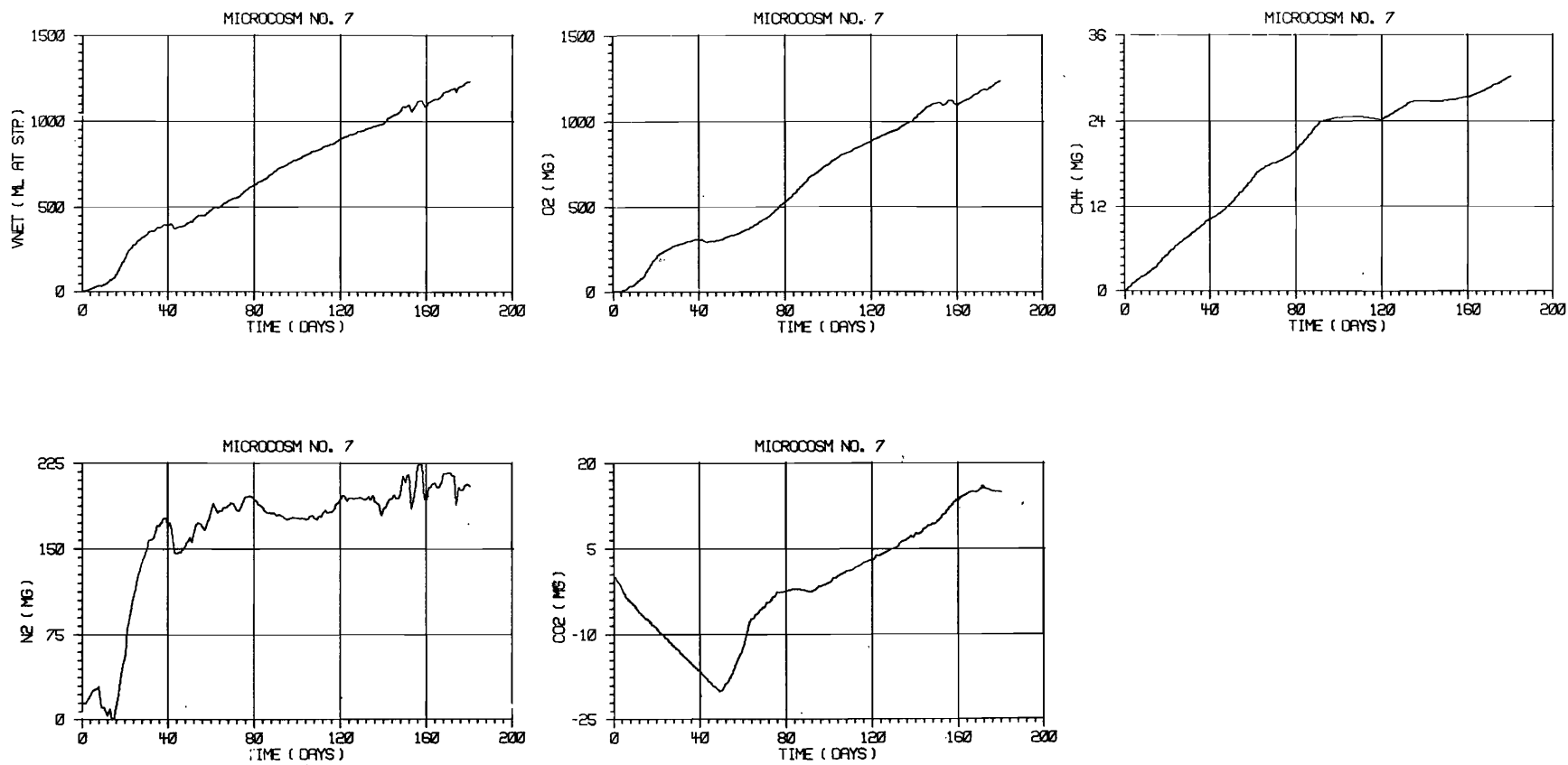

Figure 16. Mass balances of gases detected in Microcosm 7 accumulated over period of study. VNET is total gas production (ml at STP); other gases in mg. No ethylene was observed.

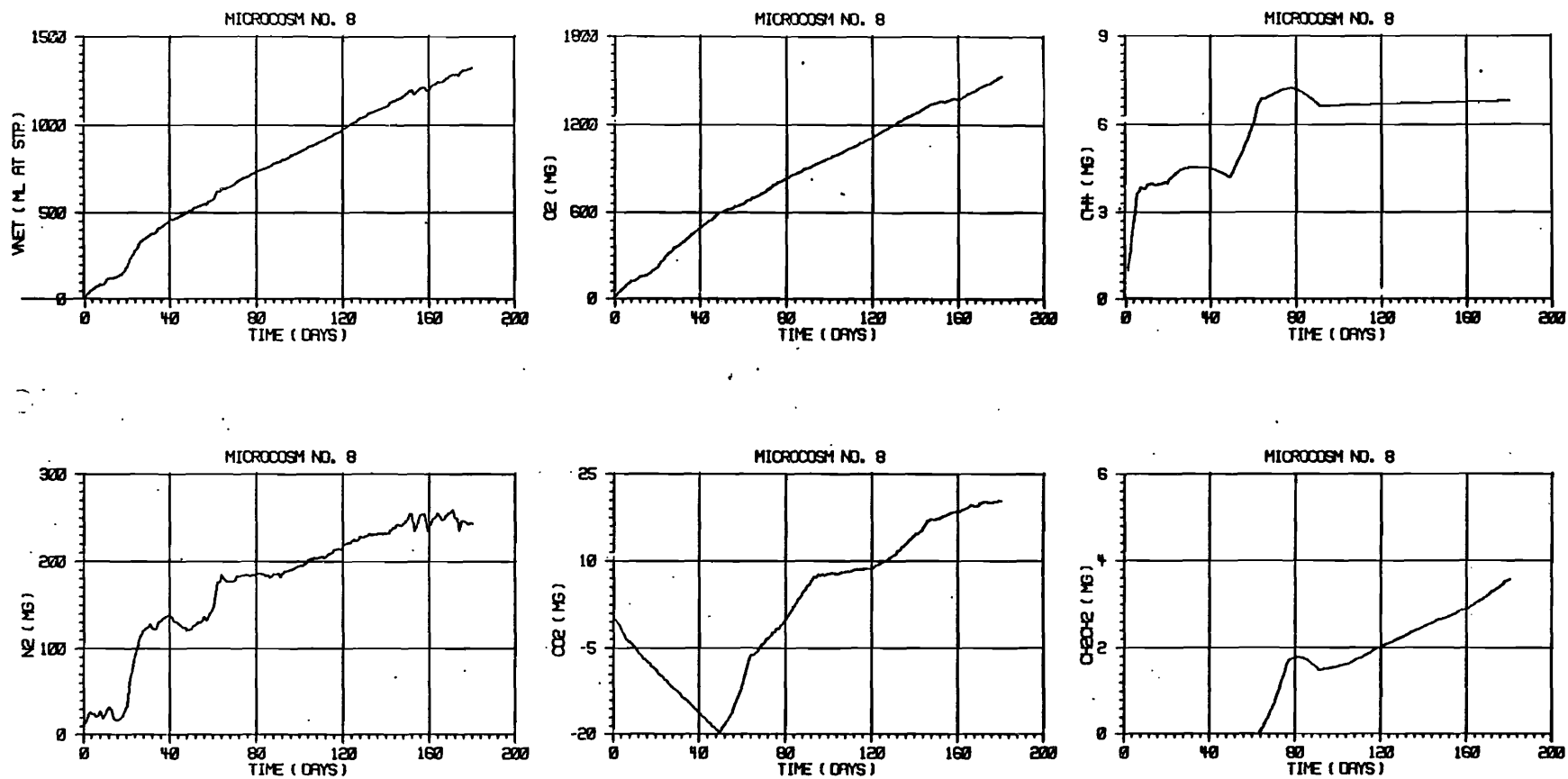

Figure 17. Mass balances of gases detected in Microcosm 8 accumulated over period of study. VNET is total gas production (ml at STP); other gases in mg.

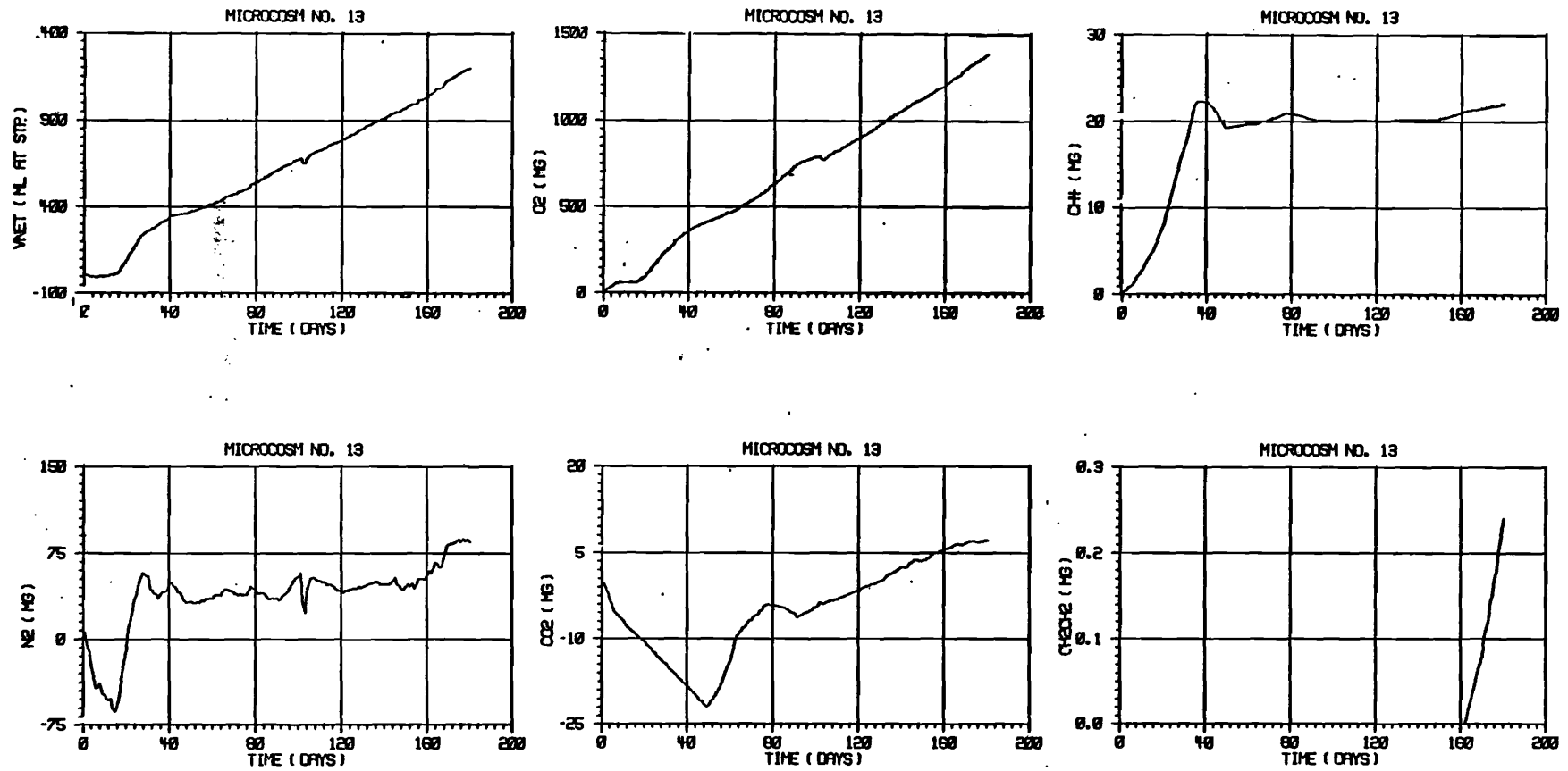

Figure 18. Mass balances of gases detected in Microcosm 13 accumulated over period of study. VNET is total gas production (ml at STP); other gases in mg.

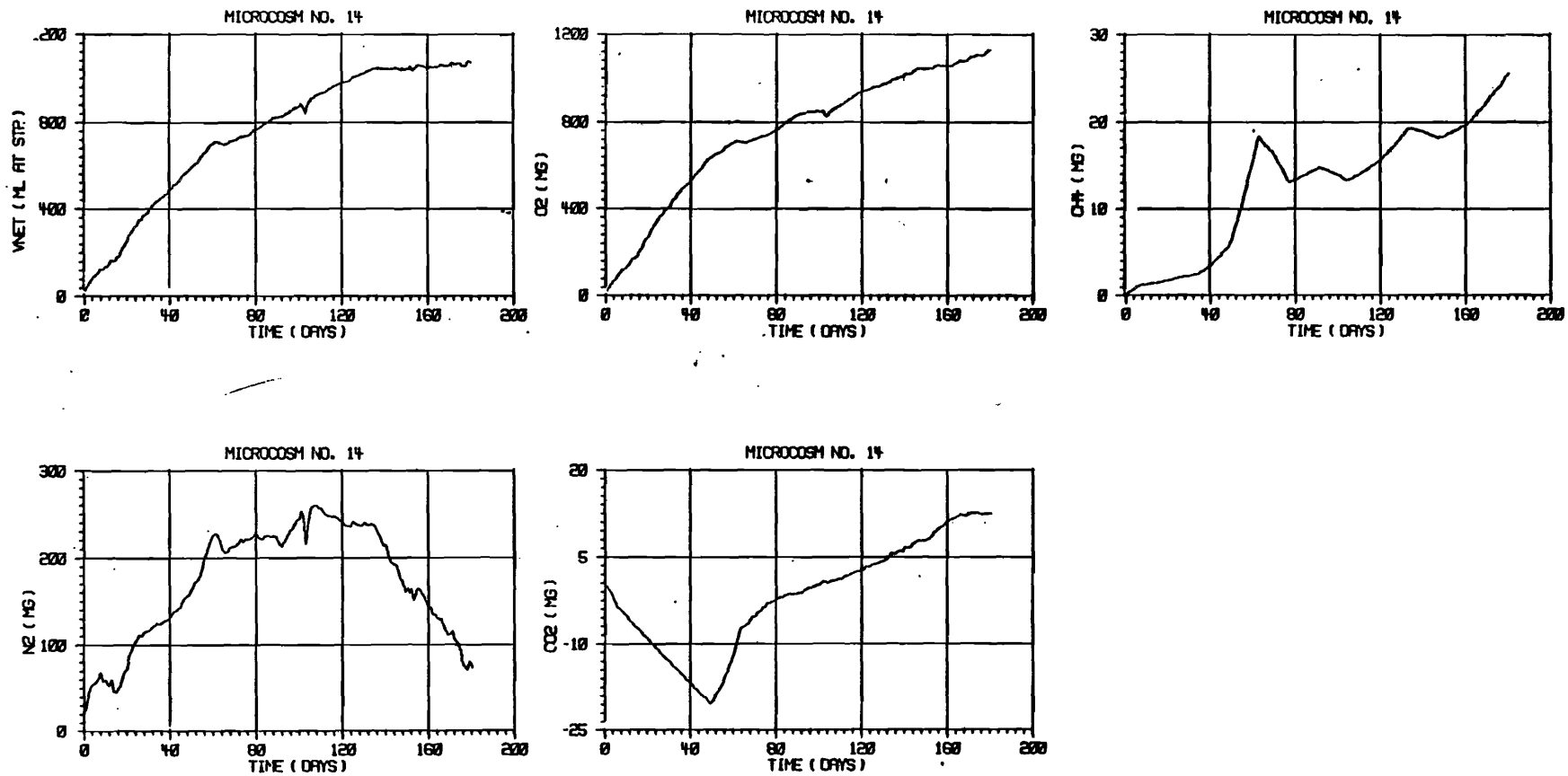

Figure 19. Mass balances of gases detected in Microcosm 14 accumulated over period of study. VNET is total gas production (ml at STP); other gases in mg. No ethylene was observed.

**RESULTS: PART III—THE DYNAMICS OF NITROGEN
IN EXPERIMENTAL MICROCOSMS**

Although the studies of nitrogen dynamics in the microcosms were designed so that there was either no input of nitrogen or input of only nitrate (300 $\mu\text{g N/l}$), it was impossible to prepare N-free media. Distilled, deionized water contained 50-500 $\mu\text{g N/l}$ of reduced nitrogen (ammonium, amines, and other organics). This was measured and taken into account in mass balance calculations.

Sediment Nitrogen

The sediments taken from Hyrum Reservoir were black in color and had a strong hydrogen sulfide smell. Generally, the sediment particles were very small and remained in suspension for several days before settling occurred. The total nitrogen content of the sediment was 2.2 g/Kg. Hyrum Reservoir has lower sediment nitrogen content than other eutrophic lakes and reservoirs apparently have (Table 12).

At the end of the 189 day incubation period the total nitrogen content of the sediments was essentially unchanged. Core samples taken at the end of incubation showed a significantly higher concentration of nitrogen in the top centimeter than at any other depth (Table 13). Although there was a vertical nitrogen gradient, the average total nitrogen in the sediments either did not change or the change was too insignificant to measure. Apparently there was a redistribution of nitrogen within the sediment column. This redistribution could take place in two ways, 1) by sediment mixing or 2) by release of sediment nitrogen and subsequently an input of sediment nitrogen by sedimentation of nitrogen contained in algal cells. The data in Table 13 indicate that the nitrogen content of samples from lower depths clustered around the overall mean value of 2.2 g N/Kg indicating minimal mixing-caused redistribution at those depths. The higher surface sediment

Table 12. Reported nitrogen content estimated for various sediment samples.

Location	g N/kg Sediment	Reference
Hyrum Reservoir (Utah)	2.2	This study
Lake Mendota (Wisconsin)	8.0	Austin (1970)
Lake Mendota (Wisconsin)	7.4	Sawyer et al. (1945)
Average of 4 hard water eutrophic lakes (Wisc.)	8.0	Keeney (1972)
Lake Mendota (Wisconsin)	10.5	Porcella et al. (1970)

Table 13. Averaged vertical distribution of nitrogen in sediments collected from microcosms after 189 days of operation (g N/kg dry weight).

Depth	Micro 1-4	Micro 5-8	Micro 9-12	Micro 13-16	Average For All Micro
0-1 cm	3.23	3.28	3.41	3.59	3.38
1-3 cm	2.42	2.51	2.47	2.55	2.49
3-5 cm	2.38	2.57	2.44	2.42	2.45
5-10 cm	2.02	2.13	2.07	2.09	2.08
10-15 cm	2.74	2.22	2.13	2.13	2.31

nitrogen could have resulted from algal cells which settled on the sediments or grew there during the experiments. However the high concentration in the surface sediments also was observed in the dark microcosms (1-4) and thus redistribution of sediment nitrogen caused by mixing due to gas bubble formation seems the most likely explanation. This likewise accounts for the lack of changes in average sediment nitrogen content observed over the period of study.

In order to further explain nitrogen dynamics, specific metabolic reactions which have been observed in aquatic ecosystems were studied using the nutrient budget approach. Nitrogen assimilation, nitrogen fixation, denitrification, nitrification were all assumed to be reactions which could be important in mass transfers in quantities and composition of nitrogen compounds. These reactions were considered individually and then integrated with the nitrogen inputs and outputs to estimate rates of reaction. Then a mass balance for each microcosm was performed.

Assimilation of Nitrogen

During the course of incubation a heavy mat of algae developed around the sides and lesser amounts overlying the sediments in the lighted microcosms. No algae were observed in the dark microcosms but a slime growth on the microcosm walls did occur. To obtain an estimate of assimilation rates in the microcosms both the nitrogen tied up in wall growth and the particulate organic nitrogen removed with the effluent were measured. The amount of nitrogen in

wall growth was determined by analyzing the algal mats. These were removed, dried, weighed, and then analyzed for total nitrogen. To estimate the amount of particulate organic nitrogen, the effluent samples were collected, filtered, and analyzed for total nitrogen collected on the filter.

Tests showed the wall scrapings contained 22 g/Kg total nitrogen and the suspended solids contained 13 g/Kg total nitrogen as compared to 2.2 g N/Kg in the sediments. Assimilation rates were estimated using the following formula:

$$A_n = \frac{1}{183 \text{ days}} \left(\text{Mass of Wall Scrapings, mg} \times 2.2\% \right) + (\text{Mean Daily SS (mg/l)}) \times (0.9 \text{ liters}) \times (183 \text{ days}) \times (1.3\%)$$

in which

- A_n = Assimilation rate in mg/day-microcosm
- 2.2% = Average percentage of nitrogen in wall scrapings
- 0.9l = Average daily volume withdrawn from microcosms
- 183 days = Duration of study of nitrogen balance
- 1.3% = Average percentage of nitrogen in suspended solids

The estimated assimilation rates (Table 14) showed that a negligible amount of assimilation occurred in the anaerobic (dark) microcosms. The aerobic microcosms displayed assimilation rates

Table 14. Estimated nitrogen assimilation rate in microcosms.

Microcosm	Wall Scrapings (mg)	Mean Daily SS in Effluent (mg/l)	Mass of SS (mg)	A_n (mg/day microcosm)	
1	420	3.3	543.5	0.089	Dark, Mean = 0.091
2	530	2.6	428.2	0.094	
3	400	2.0	329.4	0.081	
4	560	2.8	461.2	0.100	
5	10,810	12.8	2,108.2	1.449	Variable horizontal lights, Mean = 1.22
6	240	38.8	6,390.4	0.483	
7	9,160	15.5	2,552.9	1.283	
8	8,480	54.9	9,042.0	1.662	
9	3,420	119.4	19,665.2	1.808	Vertical constant lights, Mean = 1.83
10	20,080	7.0	1,152.9	2.496	
11	17,590	11.9	1,959.9	2.254	
12	5,710	5.1	840.0	0.746	
13	15,240	12.4	2,042.3	1.977	Constant horizontal lights, Mean = 1.64
14	11,620	17.7	2,915.2	1.604	
15	14,050	13.0	2,141.1	1.841	
16	8,860	5.2	856.4	1.126	

ranging from an average of 1.22 mg/day under the variable horizontal lighting conditions to 1.83 mg/day under the constant vertical lighting conditions. The variance in assimilation rates is related to the light intensity in the microcosms caused by the three different lighting configurations.

The assimilation rates in the microcosms did not vary with concentration of nitrogen in the input. This indicated that the aqueous nitrogen input was not a controlling factor in the biological activity of the microcosms.

Nitrogen Fixation

Because ethylene was observed to be produced naturally in the microcosms, it was necessary to estimate the background ethylene production to subtract it from nitrogenase production of ethylene during the acetylene assay. A timed measurement of ethylene before addition of acetylene shows that the rate of production of ethylene is considerably less than the effects of nitrogenase (Figure 29). Table 15 shows the relationship between lighting conditions and fixation rates (as N₂). Lower fixation rates were observed in microcosms where nitrate was added than in those with no nitrate added.

The relationship of nitrogen fixation rates (as N) found during this study and rates determined from other studies as they relate to the total nitrogen budget indicates that in lakes as well as the microcosms, nitrogen fixation compensates for the lack of nitrogen relative to other limiting factors in highly productive aquatic microcosms (Table 16). The attempt to estimate nitrogen fixation as a percent of assimilation is crude at best because assimilation was estimated over the period of study and nitrogen fixation only at the end of the study. As noted in the elemental nitrogen balances, nitrogen fixation varied significantly with time.

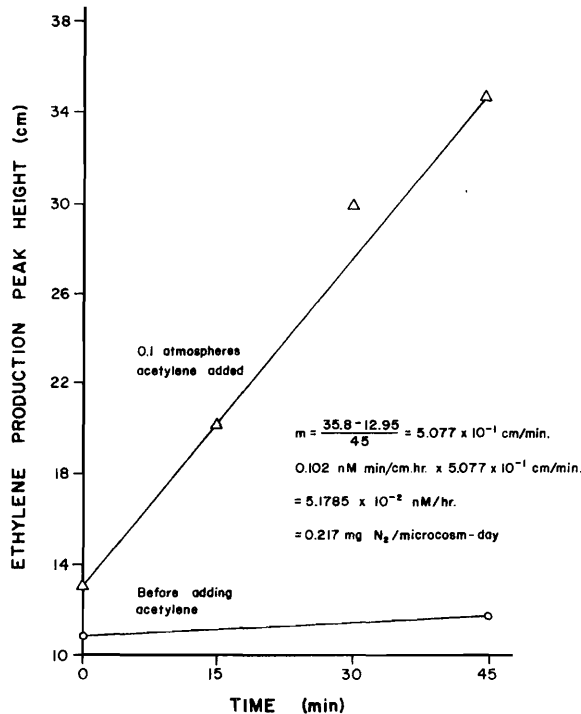

Figure 29. Example of ethylene production before and after adding nitrogenase substrate (acetylene), Microcosm 15.

Denitrification

Denitrification can occur in any microbial environment that is anaerobic. Typical denitrification sequences would include:

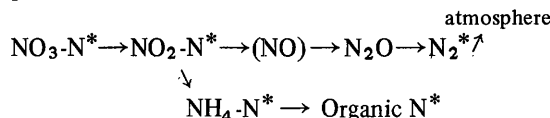

Table 15. Estimated nitrogen fixation rates for microcosms (mg N₂/microcosm day).

Dark		Variable Horizontal				Constant Vertical				Constant Horizontal					
1	2	3	4	5	6	7	8	9	10	11	12	13	14	15	16
No N	N	No N	N	No N	N	No N	N	No N	N	No N	N	No N	N	No N	N
0	0	0	0	0.19	0	0.23	0.11	0.30	0.04	0.09	0.03	0.17	0.08	0.22	0.16
Mean	0			0.14				0.12				0.16			

Average No N micr. = 0.2 mg N₂/micr. day.
 Average N micr. = 0.07 mg N₂/micr. day.
 Excluding Dark microcosms.

The asterisks show that only nitrate, nitrite, ammonium, molecular nitrogen and organic nitrogen were measured in this study. An estimate of the rate of denitrification can be obtained by determining the rate of disappearance of NO_3^- from the system in the dark microcosms. In using this method it was assumed that no chemodenitrification was taking place and also that the portion of NO_3^- that was assimilated into bacterial cells was insignificant. Because denitrification is dependent upon anaerobiosis, only the dark (anaerobic) microcosms should be capable of denitrifying in the aquatic phase.

The rates were calculated in the following manner:

Assumed first-order relationship for each day

$$\frac{dx}{dT} = -k$$

in which $x = C \cdot V$

$$\frac{\Delta CV}{\Delta T} = k C_m \cdot V_m$$

$$\Delta CV = V_i \cdot C_i - V_e \cdot C_e$$

in which

- x = mass of $\text{NO}_3\text{-N}$, mg
- T = time, days
- C = conc. of $\text{NO}_3\text{-N}$ in mg/l
- V = volume, l
- k = rate constant, days⁻¹
- m = microcosm (subscript)
- i,e = influent, effluent (subscripts)

Table 16. Relative nitrogen fixation in microcosms as compared to field measurements.

Micro-cosm	Assimilation Rate (mg N/ micr. day)	Fixation Rate (mg N/ micr. day)	% Contribution of N Fixation
1	0.089	0	0
2	0.094	0	0
3	0.081	0	0
4	0.100	0	0
5	1.449	0.19	13
6	0.483	0	0
7	1.283	0.23	18
8	1.662	0.11	7
9	1.808	0.30	17
10	2.496	0.04	2
11	2.254	0.09	4
12	0.746	0.03	4
13	1.977	0.17	9
14	1.604	0.08	5
15	1.841	0.22	12
16	1.126	0.16	14

Average contribution of fixation to no N micr. = 12% (excluding anaerobic).

Average contribution of fixation to N micr. = 5% (excluding anaerobic).

RESULTS FROM FIELD STUDIES

Lake and Location	Contribution of Nitrogen Fixation	Reference
Lake George, Uganda	33%	Horne and Viner (1971)
Clear Lake, California	43%	Horne and Goldman (1972)
Lake Windemere, England	1%	Horne and Fogg (1970)
Smith Lake, Alaska	5-10%	Alexander, V. A. personal communication
Tschornoje, Russia	8%	Kusnetzov (1959)
Lake Mendota, Wisconsin	8.5%	Fitzgerald, G. P. personal communication

} Cited in Horne (1972)

Assume $C_m = C_e$ (completely mixed system) and by substitution

$$k = \frac{V_i \cdot C_i - V_e \cdot C_m}{\Delta T(C_m \cdot V_m)}$$

Since $V_i = V_e = 0.9$ liters and $V_m = 9$ liters and $\Delta T = 1$ day, then:

$$k = \frac{(C_i - C_m)(0.9)}{(1)(C_m \cdot 9)}$$

$$k = \frac{C_i - C_m}{10 C_m}$$

The denitrification rates calculated in Table 17 were taken from a special experiment on anaerobic microcosms. In these microcosms an input feed of 10 mg/l of $\text{NO}_3\text{-N}$ was used. The reason for using this approach was due to the rapid denitrification of the low concentration (300 $\mu\text{g/l}$) of nitrate during the initial startup period. The denitrification was so rapid that concentration measurements after the first two week period showed no nitrate in the system at all. Thus to get an estimate of the rates it was necessary to wait until the end of the study and use large concentrations of nitrate in the special experiment.

The denitrification data show a very similar rate for all four microcosms tested. The rates observed would be the maximum rates you could expect under the conditions of the experiment because of the high nitrate concentrations. When using these estimated rates, the assumption is that the concentration of nitrate in the system has no effect on the rate of denitrification. This assumption needs to be evaluated further.

Nitrification

Nitrification can occur in well oxidized overlying waters and sediments, like those found in shallow waters of large lakes. Although the micro-

cosms were well mixed, the sediments in the microcosms remained essentially anaerobic. The mixing rate was maintained to allow a completely mixed aqueous phase without disturbing the sediments. Under these conditions nitrification would not be significant in the sediments. This can be substantiated from the data using the following observations:

1. An accumulation of nitrate would result if the nitrification rate were greater than the assimilatory capacity of the system or the denitrification rate. The data show no accumulation of nitrate in any of the microcosms.
2. A decrease in ammonium would accompany any nitrification. The ammonium ion concentration in the microcosms remained essentially the same as the input concentration.

Although these observations do not completely rule out nitrification, especially under steady state conditions, they do show that any net nitrification in the microcosms played an insignificant role.

Nitrogen Mass Balance

A mass balance of an aquatic system can be a valuable tool in determining the fate of a constituent. To obtain an accurate mass balance, all forms of nitrogen entering and leaving the system must be measured.

A mass balance of the nitrogen in the microcosms was calculated for the aqueous phase, gas phase, and the aqueous plus gas phase using the following method:

$$\Delta \text{Nitrogen} / \Delta \text{Time} = (\text{Nitrogen in}) \cdot (\text{Flow in}) + \text{sediment release} - \text{sediment accumulation} - (\text{Nitrogen in the microcosm}) \cdot (\text{Flow out})$$

Assuming a completely mixed system (N in the microcosm = N in the effluent) and steady state conditions ($dN/dt = 0$)

$$\text{Then } (N \text{ in} \cdot \text{Flow in}) - (N \text{ microcosm} \cdot \text{Flow out}) = (\text{Sediment accumulation} - \text{Sediment release}).$$

Table 17. Denitrification rates in anaerobic microcosms studied in a separate experiment.

Microcosm	C inf.	C eff.	k	dx/dt
1	10.056	7.153	0.041 days ⁻¹	0.293 mg/l-day
2	9.947	6.953	0.043 days ⁻¹	0.299 mg/l-day
3	9.442	7.137	0.032 days ⁻¹	0.228 mg/l-day
4	9.913	7.326	0.035 days ⁻¹	0.256 mg/l-day
Average			0.038 days ⁻¹	0.269 mg/l-day

^aThe denitrification rates calculated above were taken from microcosms in a second experiment. In these microcosms an input feed of 10 mg/l of $\text{NO}_3\text{-N}$ is being used.

If the algebraic sum is positive, the microcosm is accumulating nitrogen; if it is negative, the microcosm is releasing nitrogen.

Gas phase

This phase has been described in Results (Part II) for nitrogen gas and will be summarized only in this paragraph. Nitrogen has the ability to enter or leave the gas phase by several biological processes. Nitrogen fixing organisms can use nitrogen gas to provide a means of incorporating nitrogen into the cell structure. Also denitrifying bacteria can release nitrogen gas to the atmosphere by the reduction of nitrate under anaerobic conditions. Nitrifying bacteria can oxidize ammonium nitrogen to nitrate under aerobic conditions.

The result of the gas phase mass balance was somewhat inconclusive because the relatively small amount of N_2 removed by fixation could not be detected. Thus a nitrogen gas phase mass balance is not as useful as other phases but effects of variables on a total elemental balance for nitrogen may be masked by the larger relative impact of the gas phase on the total balance.

Aqueous phase

To fully understand the complete nitrogen cycle and to be able to identify the fate of nitrogen after entering an aquatic system the aqueous and gas phase must be studied separately. Negative accumulations in the system shows that nitrogen was released from the sediments (input < output). Any net increase shows that nitrogen accumulated in the sediments (input > output). The computer model was also used in the mass balance of this phase (Appendix B).

Dark microcosms. Microcosms 1 and 3 showed a general loss of nitrogen from the system (Figure 30). This was probably due to nitrogen release from the sediments.

Microcosms 2 and 4 showed initial accumulation (denitrification) which immediately tended toward a loss from the system (sediment nitrogen release) and then a reversal to a steady accumulation up to a steady state at about 120 days. The deviation between 2 and 4 at approximately day 140 was apparently caused by the acid spill described in the Gas Phase Results (Part II).

Aerobic, variable horizontal lighting. Microcosms 5 through 8 showed no definite trend (Figure 31). Microcosm 6 in this group did display some very unusual characteristics. At one time the sediments

and the walls of the microcosm were completely covered with a thick algal mat. About midway through the study the mat began peeling off the sides of the microcosms and in a short period of time the microcosm was almost completely devoid of any algae on the sides or bottom of the microcosm. A dense population of ostracods were visible in the murky water. The effects these grazing organisms had on the disappearance of the algal mats in this microcosm is unknown. No nitrogen fixation was observed in this microcosm (Table 15) and it did receive an input of nitrate nitrogen. The sequence of events—addition of N, development of ostracod population, etc.—may have resulted in this phenomenon.

Microcosms 5 and 8 generally showed an accumulation of nitrogen in the system (fixation and use of input nitrogen). Microcosm 7 showed a release of nitrogen and also the highest fixation rate of the four horizontal variable systems. The fixation was measured at the end of the study (day 189) and as can be seen in Figure 31 a gradual upturn indicates that for the last 40 days the microcosm was accumulating nitrogen. Thus it is likely that fixation began rather late (about day 140) in Microcosm 7.

Aerobic, constant vertical lighting. Microcosms 9 through 11 showed several definite trends (Figure 32): Numbers 9 and 11 which had no nitrate added in the influent showed a constant loss of nitrogen throughout the study. This was due to the fixation and then loss in the effluent of particulate organic nitrogen which outweighed any input from the gas or sediment phase.

Microcosms 10 and 12 showed a continual gain in nitrogen. This was due to the addition of nitrate nitrogen in the influent. Nitrogen input from the sediment (ammonification) or gas phase (fixation) remained as algae in the microcosm and thus outweighed the amount lost in the effluent. Microcosm 11 remained relatively constant after day 70 indicating a steady state with input (fixation, organic, and sediment nitrogen) balancing output (outflow).

Aerobic, horizontal. Microcosms 14 and 16 showed trends similar to 10 and 12 (Figure 33). Microcosms 13 and 15 showed only small gains or losses during the study, while Microcosms 14 and 16 showed large gains of nitrogen. This was also due to the fact that the nitrogen in the influent and from the gas (fixation) and sediment phase outweighed the nitrogen leaving in the effluent. Greater accumulation occurred in those receiving nitrate. The trend toward increasing accumulation of nitrogen in Microcosm 15 can be accounted for by the high rate of fixation. By day 189 fixation in Microcosm 15 was the greatest in this set of 4 (Table 15).

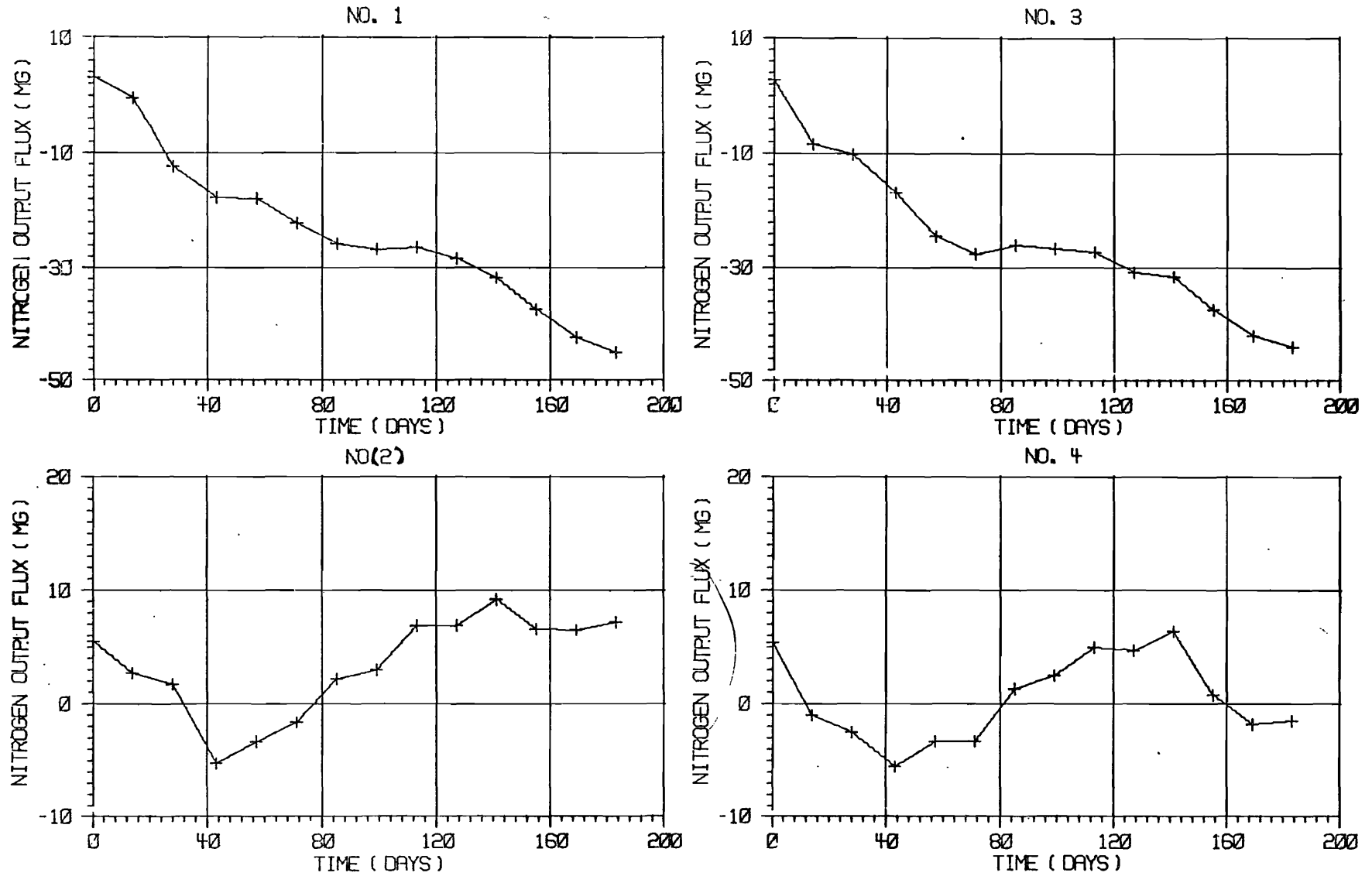

Figure 30. Aqueous phase mass balance for dark (anaerobic) Microcosms 1, 2, 3, and 4. Microcosm 1 receives no nitrate or mercury; 2 receives $300 \mu\text{g N/l}$ nitrate and no mercury; 3 receives no nitrate and $50 \mu\text{g Hg/l}$ mercury; and 4 receives $300 \mu\text{g N/l}$ nitrate and $50 \mu\text{g Hg}^{++}/\text{l}$.

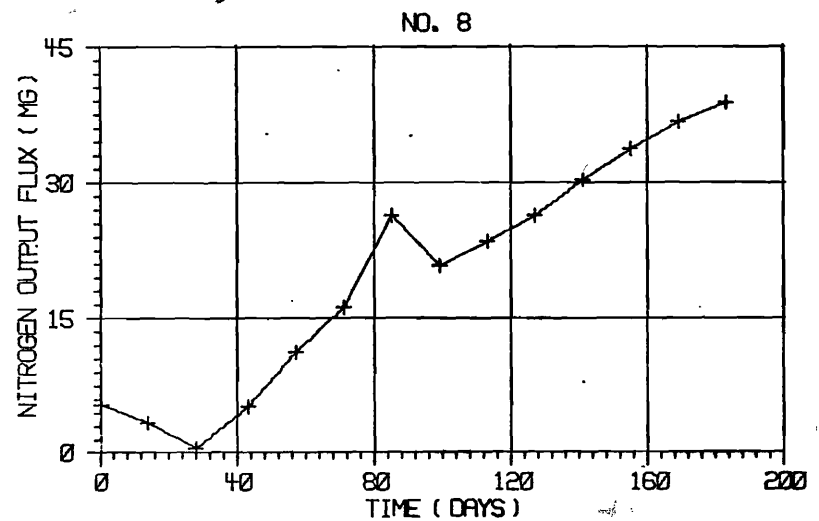
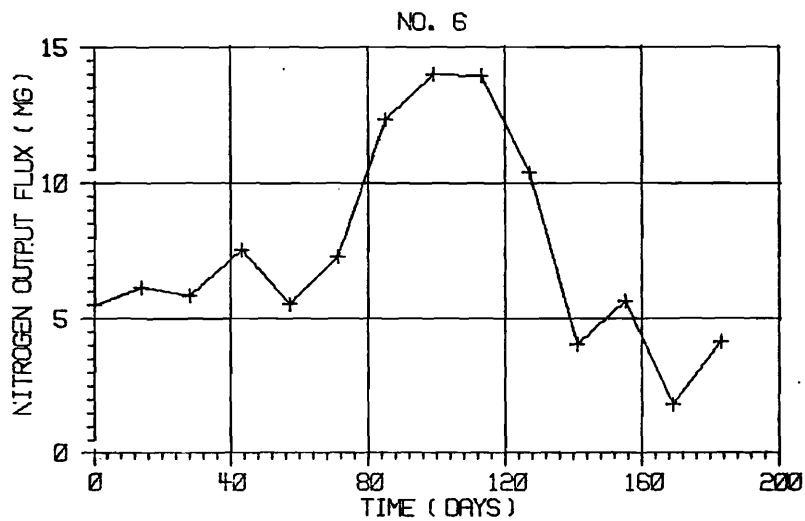
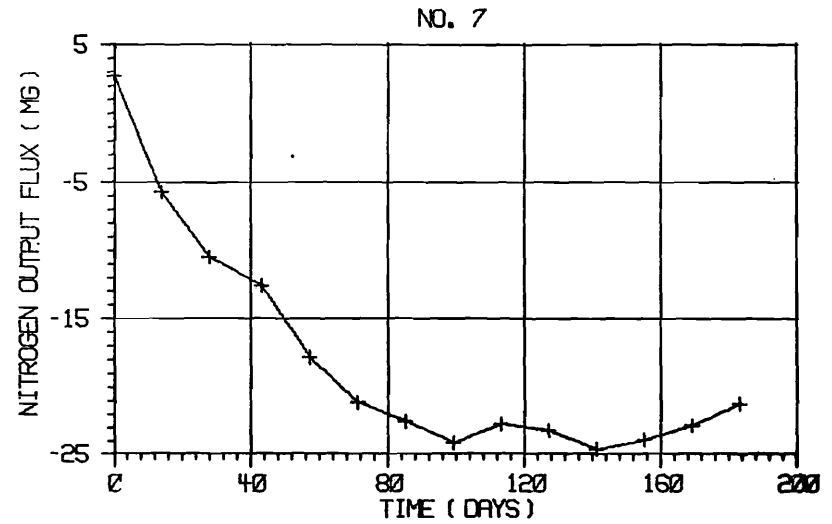
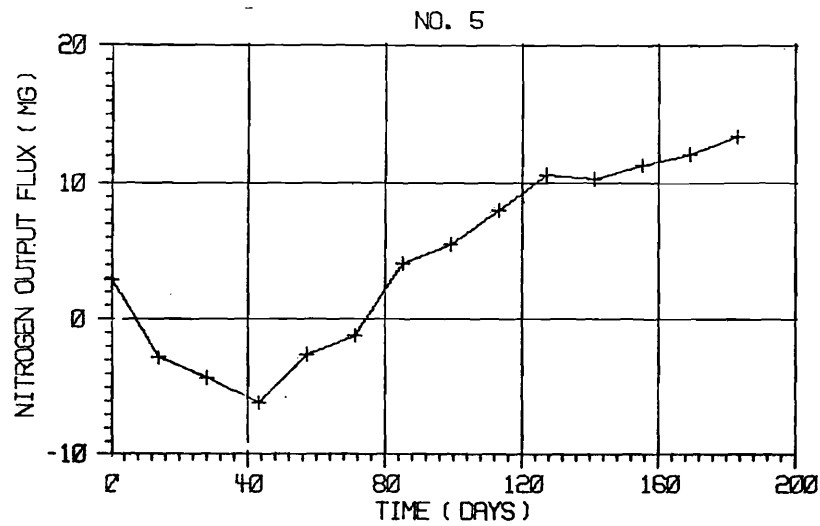

Figure 31. Aqueous phase mass balance for horizontal and variable lighted (aerobic) Microcosms 5, 6, 7, and 8. Microcosm 5 receives no nitrate or mercury; 6 receives $300 \mu\text{g N/l}$ nitrate and no mercury; 7 receives no nitrate and $50 \mu\text{g Hg/l}$ mercury; and 8 receives $300 \mu\text{g N/l}$ nitrate and $50 \mu\text{g Hg}^{++}/\text{l}$.

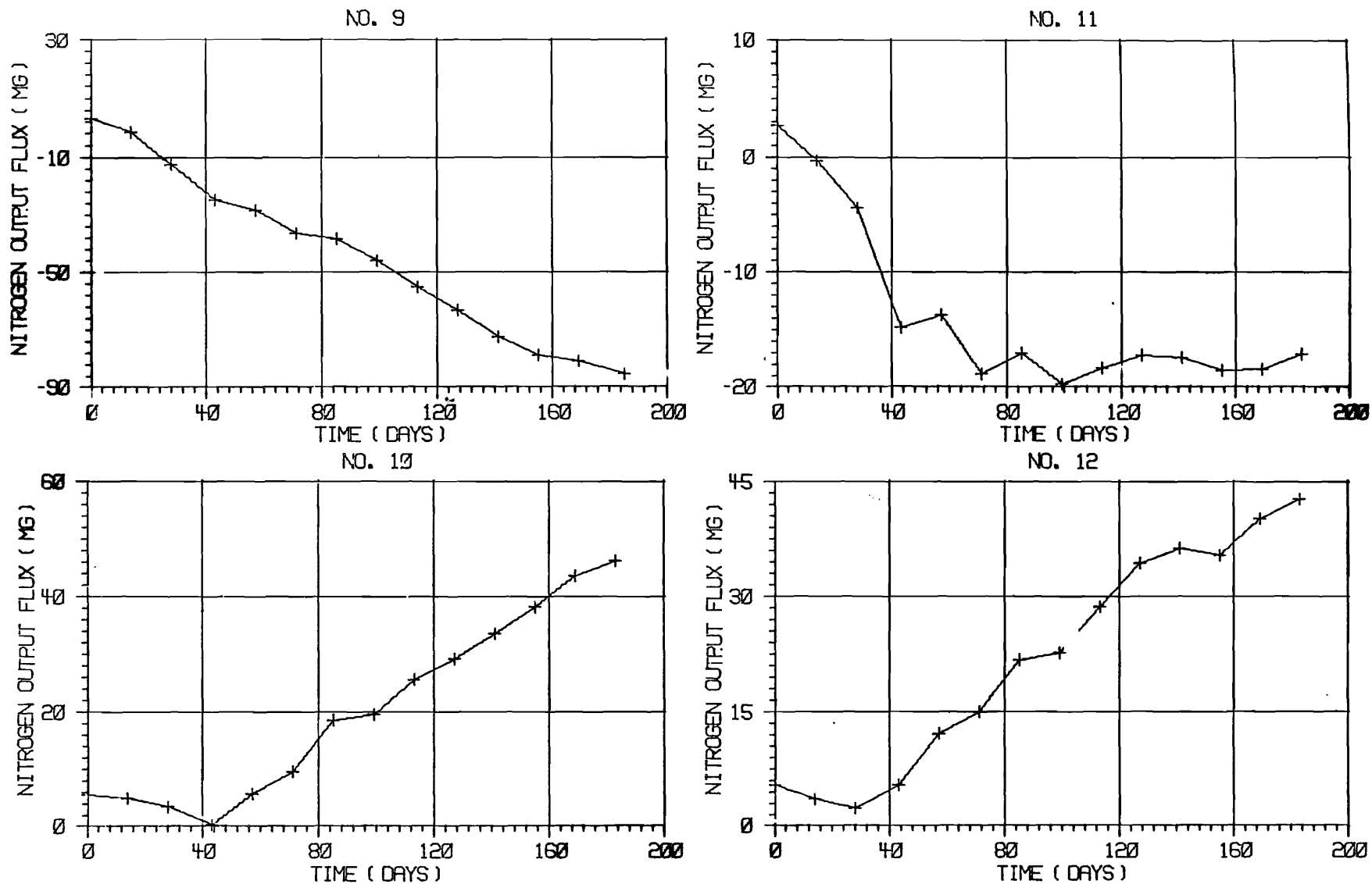

Figure 32. Aqueous phase mass balance for vertical and continuously lighted (aerobic) Microcosms 9, 10, 11, and 12. Microcosm 9 receives no nitrate or mercury; 10 receives $300 \mu\text{g N/l}$ nitrate and no mercury; 11 receives no nitrate and $50 \mu\text{g Hg/l}$ mercury; and 12 receives $300 \mu\text{g N/l}$ nitrate and $50 \mu\text{g Hg}^{++}/\text{l}$.

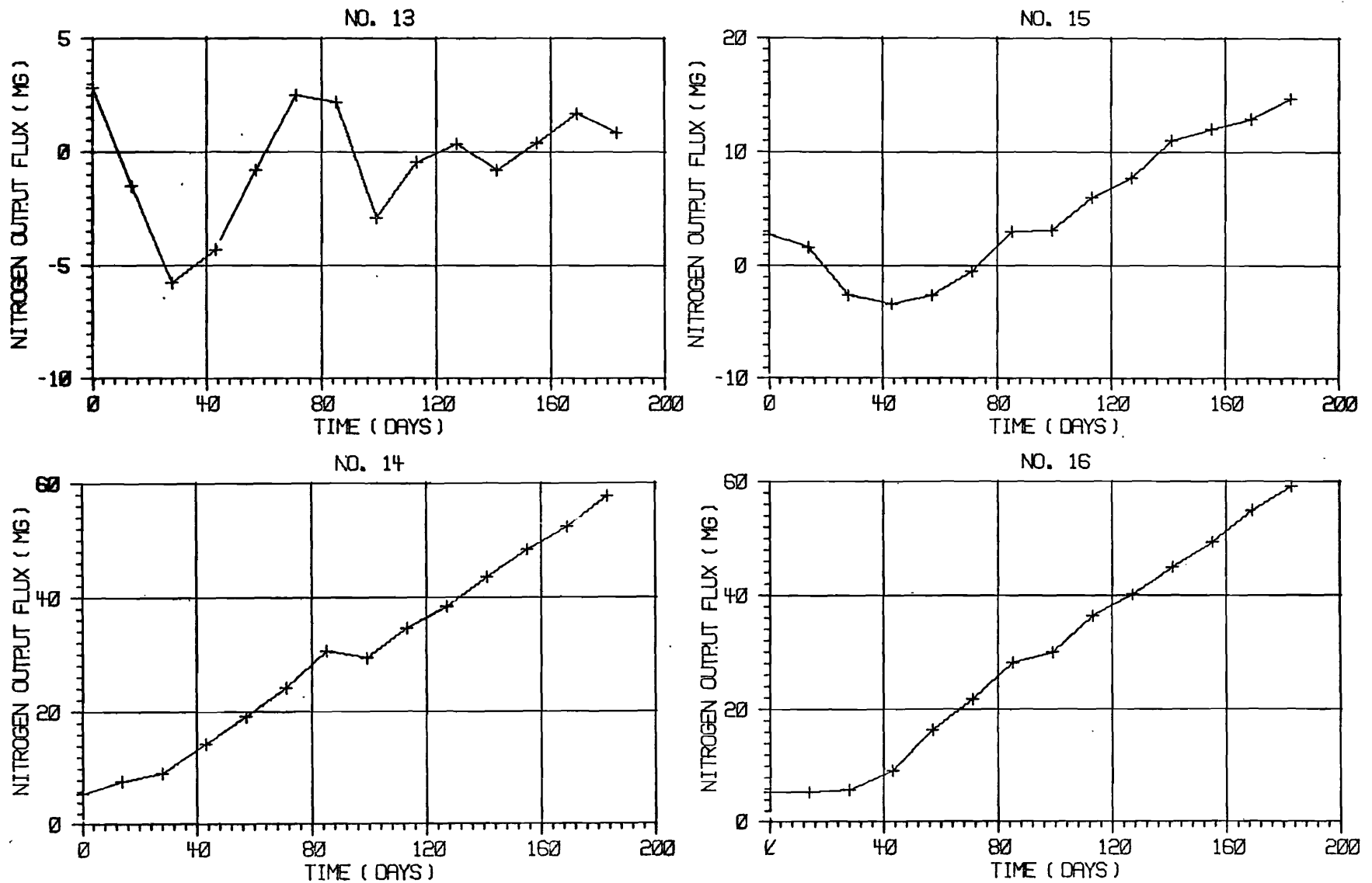

Figure 33. Aqueous phase mass balance for horizontal lighted (aerobic) Microcosms 13, 14, 15, and 16. Microcosm 13 receives no nitrate or mercury; 14 receives $300 \mu\text{g N/l}$ nitrate and no mercury; 15 receives no nitrate and $50 \mu\text{g Hg/l}$ mercury; and 16 receives $300 \mu\text{g N/l}$ nitrate and $50 \mu\text{g Hg}^{++}/\text{l}$.

Discussion of Results of Nitrogen Studies

Analogy of microcosms to actual lake conditions

An important part of this laboratory study was to determine to what extent the results could compare to the natural systems. In this experiment the lighted microcosms can be compared to a shallow lake in which mixing is continuous and stratification during summer months does not occur. Examples of this type of aquatic system would be small irrigation ponds, littoral areas in lakes or very shallow reservoirs where wave action or currents keep the water well mixed. In such an environment the ratio of surface area to volume is very large compared with deep reservoirs. These conditions exist in the shallow littoral areas of Hyrum Reservoir during the summer months (Drury et al., 1975).

The dark microcosms can be compared to the deep zones of Hyrum Reservoir (or any deep lake) during the summer months. During this time the bacterial action decreases the dissolved oxygen content of the water until completely anaerobic conditions prevail. Under stratified conditions as occur during the summer in temperate zone lakes, three distinct zones usually exist. The upper zone (epilimnion) is usually well-mixed and is the productive zone for algae. The zone is usually characterized by high light, high dissolved oxygen concentrations and high pH values. These conditions are caused by the removal of CO_2 by algal photosynthesis (raising pH) and the release of O_2 as a by-product. Under these conditions nitrogen fixation, nitrification, and assimilation can occur. The metalimnion is a transition zone in which characteristics of the overlying zone or underlying zone can prevail. The deep zone (hypolimnion) is characterized by anaerobic conditions due to the utilization of oxygen by bacteria during respiration. Under this condition both denitrification and ammonification can take place.

The microcosms are a physical model of the littoral area epilimnion overlying the sediment phase (lighted microcosms) and a model of the pelagic area hypolimnion overlying the sediment phase (dark microcosms); no metalimnion or pelagic epilimnion was modeled. Thus, nitrogen dynamics were studied with respect to these models and the discussion of those results will be as follows: 1) The ideal nitrogen cycle and 2) the actual nitrogen cycle in the microcosms.

Ideal nitrogen cycle

The ideal nitrogen cycle is depicted in Figure 34. The processes that can occur simultaneously are

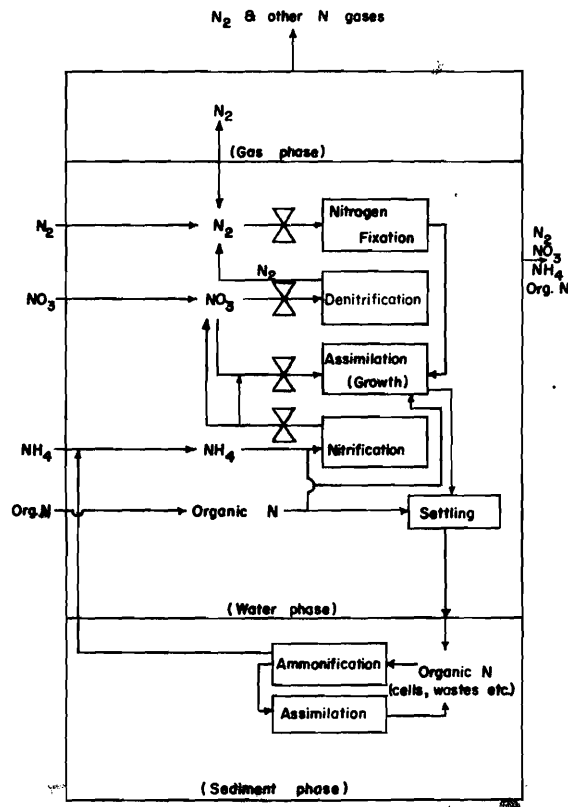

Figure 34. Nitrogen cycle in microcosms.

fixation, denitrification, nitrification, ammonification, and assimilation. Optimum conditions for each process can usually be found in stratified reservoirs. Sediment nitrogen could participate resulting from breakdown of organic matter forming gases and soluble inorganic compounds (ammonium) with subsequent release to the overlying water as gas bubbles deform sediment structure and cause mixing.

These processes cause a change in the forms of nitrogen present depending upon which process is dominating the system. If denitrification is the dominating process, a decrease in the nitrate accompanied by an increase in nitrogen gas production can be expected. If ammonification is dominating a decrease in organic nitrogen will be followed by an increase in ammonium.

When nitrification is a major process a decrease in ammonium will be followed by an increase in nitrate. If assimilation is the dominating process the inorganic forms of nitrogen will decrease as the organic nitrogen increases. Nitrogen fixation could be classified as assimilation; however, a decrease in inorganic nitrogen would not accompany the increase in organic nitrogen, but would correspond to a decrease in nitrogen gas. Due to the large amount of nitrogen gas available in natural waters, a reduction in

nitrogen gas concentration likely would not be easily measurable even at a very high rate of nitrogen fixation.

Any of these processes (fixation, ammonification, nitrification, and denitrification) could become significant depending on the environmental conditions found in the body of water.

Nitrogen cycle in microcosms

Anaerobic microcosms. Figure 35 shows the nitrogen cycle as it occurred in the anaerobic microcosms. Ammonification and denitrification accounted for most of the changes that occurred in the forms of nitrogen present.

Sediment release (ammonification) occurred at a very rapid rate in the anaerobic microcosms. The effluent concentration of ammonium averaged greater than four times the influent concentration.

Analysis of the sediments after completion of the study showed no measurable decrease in the total nitrogen content. The increase of ammonium in the effluent was probably due to the breakdown of influent organic nitrogen to ammonium.

Denitrification rates caused the concentration of nitrate to decrease to zero in a short period of time thus making it impossible to get an accurate estimate

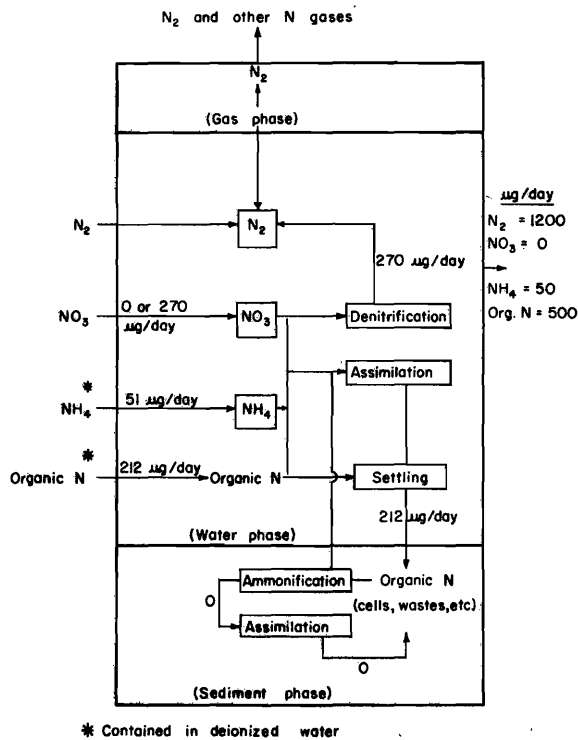

Figure 35. Nitrogen cycle in anaerobic microcosms.

of the rate of depletion of nitrate. The nitrate concentrations in Microcosms 2 and 4 decreased from the start of the experiment and after the third analysis day (42 days) remained essentially zero. This was probably due to the fact that anaerobic conditions took time to develop and the bacterial populations responsible for denitrification were adjusting to their new environment.

Assimilation played a minor role in the anaerobic microcosms. The calculated assimilation rates for the anaerobic microcosms ranged between 0.1 mg N/micr.-day to 0.089 mg N/micr.-day. Bacteria probably accounted for most of the assimilation.

Aerobic microcosms. Figure 36 shows the nitrogen cycle as it actually occurred in the aerobic microcosms. Nitrogen fixation and assimilation were the predominant processes acting in the aerobic microcosms.

Assimilation rates in the aerobic microcosms ranged between 0.5 mg N/microcosm-day to 2.5 mg N/microcosm-day. The most striking feature of the aerobic microcosms was that no significant difference in growth was observed between the microcosms with 300 µg/l of nitrate added in the influent and those with no nitrate added in the influent. The average assimilation rate is reflected by the mass of growth on the walls and the mass of organic material leaving the

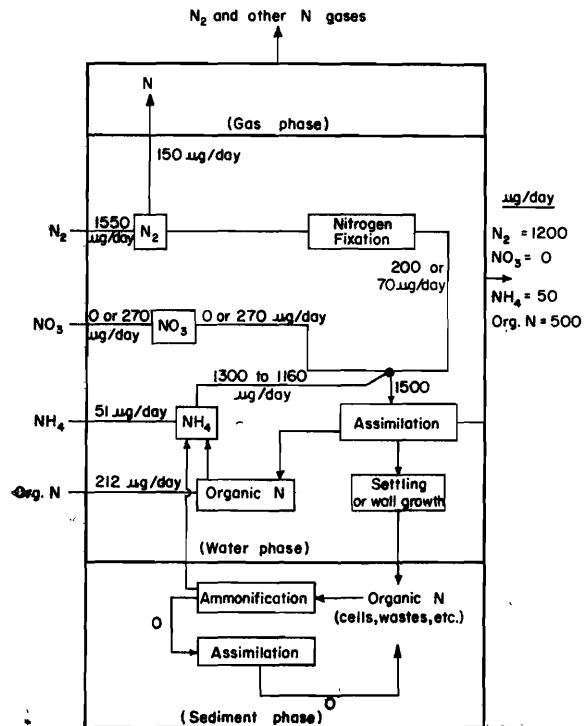

Figure 36. Nitrogen cycle in aerobic microcosms (average values).

system as effluent. An average nitrogen assimilation rate of 1.76 mg/day-microcosm was obtained in the microcosms that had no nitrogen added compared with 1.36 mg/day-microcosm in the microcosms that had nitrogen added.

Although all microcosms started with the same sediment and incubation periods, each community developed independently and some in different directions. Microcosm 6 was the most striking example of this fact. After a small amount of wall growth had developed the algae mats peeled from the sides and throughout the entire experiment the walls remained free of growth although the other microcosms developed so much growth on the walls it was impossible to see through them. In Microcosm 6 ostracods may have been responsible but it is unclear how they prevented the wall growth.

With assimilation rates as high as 2.5 mg N/micr.-day, it is apparent that the nitrogen in the influent (~ 0.27 mg N/micr.-day) could not supply the large amount of nitrogen needed for growth. Sediment release could have supplied some of the nitrogen requirement but it is unlikely that it was a high percentage. Initially the sediments had 18,580 mg of nitrogen and a removal of 1 percent would amount to 186 mg or about 1 mg/day. Thus an undetectable loss of total nitrogen (CV = 2 percent) could more than account for nitrogen release from sediments. Dark microcosms 1 and 3 which received no nitrate and were not photosynthesizing, lost ~45 mg of nitrogen which indicates a sediment nitrogen supply of about 0.28 mg N/microcosm-day.

Nitrogen fixation tests showed that under conditions of limiting nitrogen the algae present in the microcosms had the ability to fix nitrogen from the atmosphere as needed. Thus the average contribution of nitrogen fixation to the microcosms with no nitrate added was about double that of the microcosms that received 300 µg/l of nitrate (Table 16). This seems to indicate that in an aquatic system the nitrogen fixing algae are capable of fixing as much nitrogen as is needed for growth. Thus nitrogen could be limiting relative to other nutrients but could not be totally controlled to prevent algal growth.

Results of overall mass balance

The results of the total nitrogen mass balance in the microcosms were inconclusive because of the large effect that the gas phase displayed on the system.

Mercury additions of 50 µg/l in Microcosms 3 and 4, 7 and 8, 11 and 12, and 15 and 16 had no measurable effect on the nitrogen mass balance. The mercury concentrations apparently were not large enough to inhibit algal growth.

The mass balance of the aqueous phase showed some definite trends. In the anaerobic microcosms both 1 and 3 showed a net loss of nitrogen from the microcosm. Thus the total mass of nitrogen input to the microcosm was less than the total mass of nitrogen leaving the microcosm in the effluent. This would indicate a release of nitrogen from the sediments into the aqueous phase, probably as a result of ammonification of organic nitrogen stored in the sediments.

Microcosms 1 and 3 had no addition of nitrate in the influent. Microcosms 2 and 4 had 300 µg/l of nitrate-nitrogen added in the influent and except for minor variations operated at steady state.

By subtracting the nitrogen present at day 0 from the nitrogen accumulated by day 180, a rate for the disappearance of nitrogen from the aqueous phase can be calculated as follows:

$$\frac{(\text{Initial N Present}) - (\text{Final Accumulated N at Day 180})}{180} = K$$

Thus, loss is negative (input < output) and accumulation is positive (input > output).

Using this method the rate of loss of nitrogen in the aqueous phase in number 1 microcosm is equal to 0.28 mg/day and for number 3 is equal to 0.27 mg/day. Because the N₂ gas mass balance in Microcosm 1 showed a net gain to the system (Figure 10), the nitrogen from the aqueous phase must have accumulated in the gas phase via denitrification. The total N balance shows an increase of 120 mg during the period. A total rate for the entire system can be calculated using the same method used for the aqueous phase. The result is a final rate of 0.67 mg/day. By subtracting the rate for the aqueous phase from the rate for the total system an estimate of the rate for the gas phase can be calculated as follows:

$$(\text{Total Rate}) - (\text{Aqueous Rate}) = \text{Gas Rate}$$

Table 18 shows the final K values for the aqueous and gas phase and the total K value for the system for each microcosm. An attempt to relate the gas phase mass balance to nitrogen fixation indicates the possibility of a trend (Figure 37); however, the nitrogen fixation was measured only once, on the last day and it was a little unreasonable to expect exact concurrence between a single estimator and an overall average in systems which are as dynamic as these microcosms apparently were. If nitrogen fixation measurements were feasible at regular intervals, concurrence would be expected and nitrogen fixation could probably be correlated to the gas phase mass balance.

Table 18. Average rates of loss or accumulation in aqueous and gas phases for microcosms.

Micro-cosm	K_c^a Total (mg/day)	K_c Aqueous (mg/day)	K_c Gas (mg/day)	Important Processes
1	0.66	-0.28	0.94	Sediment release and ammonification
2	1.64	0.01	1.63	Sediment release, ammonification, and denitrification
3	-0.27	-0.27	-0.54	Sediment release and ammonification
4	-0.06	-0.04	-0.10	Sediment release, ammonification, and denitrification (acid spill)
5	-0.28	0.06	-0.22	Assimilation and fixation
6	-0.94	-0.01	-0.95	Predation, assimilation, and fixation
7	1.14	-0.13	1.01	Assimilation and fixation
8	1.24	0.19	1.05	Assimilation and fixation
9	1.61	-0.54	2.15	Predation, assimilation, and fixation
10	-0.89	0.22	0.67	Assimilation and fixation
11	0.79	-0.11	0.90	Assimilation and fixation
12	1.50	0.20	1.30	Assimilation and fixation
13	0.44	-0.01	0.55	Assimilation and fixation
14	0	0.29	-0.29	Assimilation and fixation
15	0.82	0.07	0.75	Assimilation and fixation
16	1.00	0.30	0.70	Assimilation and fixation

^a K_c = Rate of Change (dx/dt).

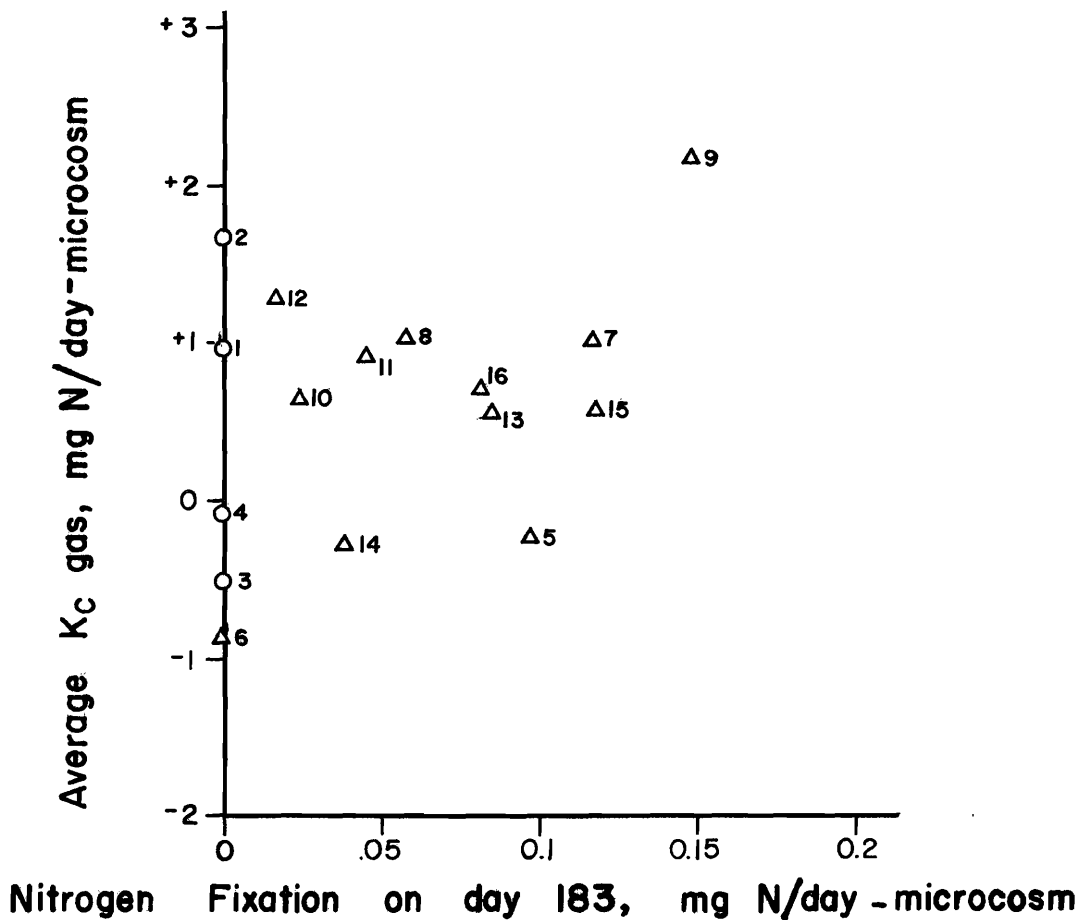

Figure 37. The overall gas phase mass balance does not account for N fixation as measured near the end of the experiment (o, dark; Δ, light; microcosms; number is microcosm).

**RESULTS AND DISCUSSION: PART IV—THE FATE OF
MERCURY IN EXPERIMENTAL MICROCOSMS**

Mercury and Sediments

According to the experimental design, 50 µg/l of mercury was injected daily into 8 of the 16 microcosms (3, 4, 7, 8, 11, 12, 15, 16). These were opened and the sediments of those microcosms receiving mercury were analyzed for total mercury. Samples for total mercury analyses were taken from the sediments by core sampling at the end of the experiment. The core samples were sectioned into lengths of 0-1 cm, 1-3 cm, 3-5 cm, 5-10 cm, and greater than 10 cm. Below the 10 cm depth in all of the microcosms, the mercury levels were within the experimental error of the value of mercury in the initial sediments before they were exposed to mercury. Values ranged from 0.05 to 0.17 µg Hg/gm sed. These individual sections were carefully mixed to enable an average mercury concentration to be measured for the various sediment depth ranges.

Microcosms 3 and 4 were anaerobic and both had much lower mercury levels in the upper centimeter of sediments (Table 19) than did the aerobic microcosms (7, 8, 11, 12, 15, 16). The upper centimeter of sediments in microcosms 3 and 4 contained approximately 4 µg Hg/gm sed. whereas the remaining microcosms contained from 9-27 µg Hg/gm sed. in the upper centimeter of sediments.

In the one to three centimeter range, a substantial reduction in mercury levels can be seen. In general, the mercury levels in the one to three centimeter range were roughly one-half of the mercury levels in the zero to one centimeter range. At this depth, the anaerobic microcosms again had substantially lower mercury concentrations than the aerobic microcosms.

In the three to five centimeter range, the mercury level was approximately one-tenth of the surface levels and the anaerobic microcosms had less mercury than the aerobic ones.

Only traces of mercury were found below the five centimeter depth (Figures 38 through 42). In the five to ten centimeter sediment depth range, the mercury concentrations were between 0.8 and 0.16 µg Hg/gm sed. The above values were still greater than the initial sediment mercury concentration of 0.06 µg Hg/gm sed. The initial value of 0.06 µg Hg/gm sed. at the start of the experiment is in agreement with Shacklette (1971) who reported that 0.055 µg Hg/gm sed. (geometric mean concentration) was representative of the western United States.

At a depth of 10 cm or more the mercury levels in the sediments were generally within a factor of two

Table 19. Mercury in sediments vs. sediment depth (µg Hg/g dry sed.).

Sed. Depth (cm)	Microcosm								
	Receiving Mercury								Not Receiving Mercury
	3	4	7	8	11	12	15	16	
0-1	3.55	4.04	10.00	9.10	13.56	26.96	8.95	16.73	0.27
1-3	1.36	0.44	6.78	9.52	5.64	5.26	4.66	1.45	0.12
3-5	0.13	0.39	7.00	1.62	1.48	0.61	1.40	0.36	0.13
5-10	0.10	0.12	0.16	0.14	0.08	0.15	0.15	0.12	0.04
> 10	0.17	0.12	0.09	0.10	0.07	0.06	0.05	0.15	0.04

Initial sediment total mercury = 0.06 µg Hg/g dry sediment.

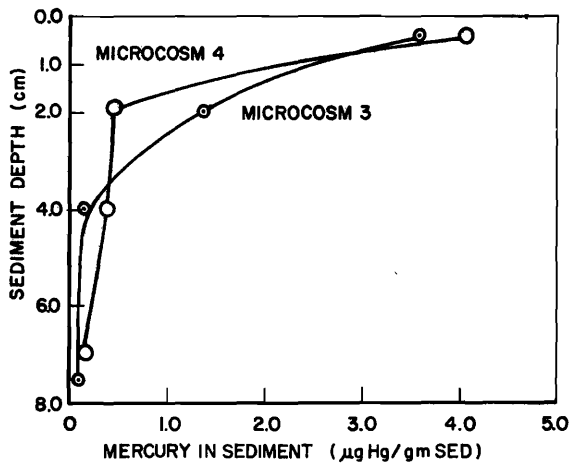

Figure 38. Sediment depth vs. mercury in sediment (Microcosms 3 and 4).

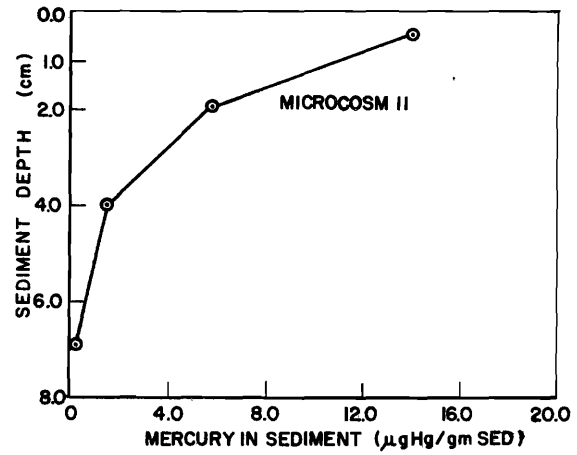

Figure 40. Sediment depth vs. mercury in sediment (Microcosm 11).

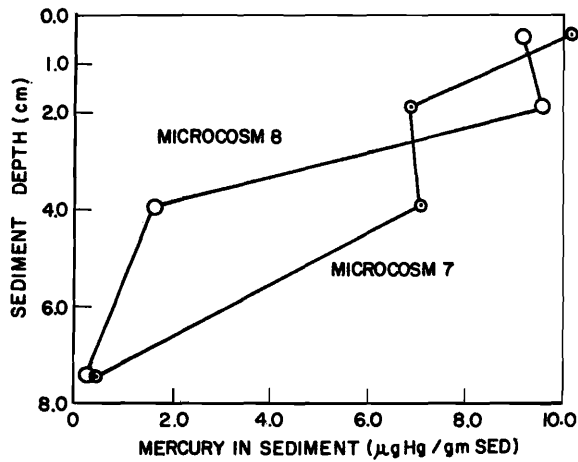

Figure 39. Sediment depth vs. mercury in sediment (Microcosms 7 and 8).

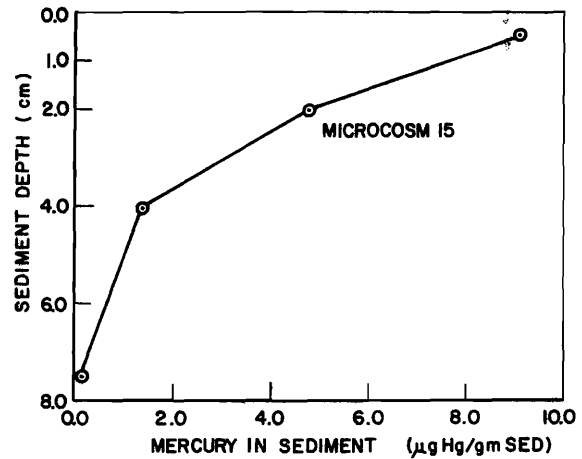

Figure 41. Sediment depth vs. mercury in sediment (Microcosm 15).

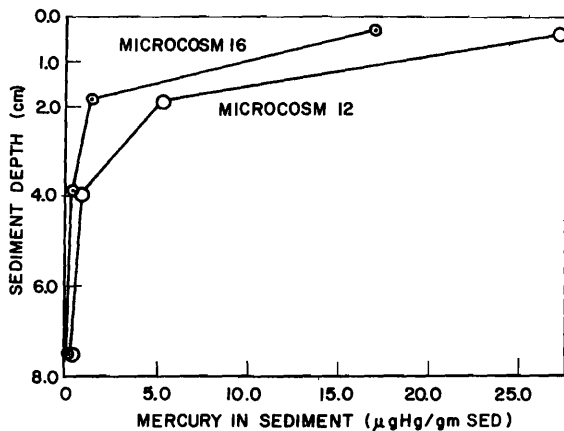

Figure 42. Sediment depth vs. mercury in sediment (Microcosms 12 and 16).

of the initial sediments. Because of the difficulties encountered in sampling and interpreting the standard curve, it is highly likely that these values are within experimental error or natural deviations in the mercury levels of the sediment. These low mercury values are taken from the standard curve in a region of uncertain accuracy—the distance between the blank and the lowest standard. Better techniques are now available to measure mercury.

By bacterial action, all aerobic microcosms produced considerable amounts of gas in the sediments. When the individual gas pockets became large enough, the muds could no longer contain the bubbles formed and they escaped. As the bubbles broke loose from the sediments, a hole was formed. This cavity was immediately filled with water and surficial mud rich in mercury, thus allowing deeper penetration of mercury into the sediments than would otherwise have been possible.

The extraordinarily high value for mercury in microcosm No. 12 at the 1 cm depth may have been due to a floc of organic material that separated from the walls of the microcosm and settled upon the sediments. The floc became a part of the upper one centimeter sediment layer that was sectioned from the core sample, and was measured as total sedimental mercury. As can be seen by comparing Table 19 with Table 20, organic material is much higher in mercury than the sediments.

Microcosms three and four were anaerobic and the water above the muds was slightly acidic. Mercury is more readily adsorbed to particulate matter and other surfaces at a basic pH than at an acidic pH. An acidic pH thus would tend to reduce the amount of adsorbed mercury resulting in an increase of mercury in solution. In general, the anaerobic microcosms had a water-phase mercury level higher than the aerobic

Table 20. Total mercury in wall scrapings.

Microcosm	µg Hg/g Dry Weight Wall Scrapings	Total Microcosm Dry Wall Scrapings (g)
3	--a	0.40
4	--a	0.56
7	172.6	9.16
8	103.6	8.48
11	244.1	17.59
12	287.3	5.71
15	197.2	14.05
16	332.1	8.86

^aNot analyzed.

microcosms (Appendix D) and a sediment mercury level lower than the anaerobic microcosms (Table 19).

Mercury Balance

The mercury balance consisted of three parts (Tables 21 and 22): Total sediment mercury, total algal mercury, and total mercury in the water solution. The gas phase above the water in the microcosms was tested for dimethyl-mercury; however, none was detected. The extremely volatile dimethylmercury was the form of mercury most likely to have been lost to the gas space above the water in the microcosms. Although uncertain methodology may have accounted for not observing gas phase mercury, apparently no mercury compounds were transferred to the gas phase.

The microcosms were operated continuously for 189 days and 50 µg of inorganic mercury was added daily resulting in a total of 9450 µg of mercury added during the experiment. With the exception of the anaerobic microcosms (No. 3 and No. 4), the accountability of mercury from sediments, algae, and water phase was within an acceptable range. The percentage of the total mercury accounted for, found by summing the values for sediments, algae, and water, for each microcosm, ranged from 84 to 109 percent in the aerobic microcosms but was about 34 percent in the anaerobic microcosms.

The lack of accountability for mercury in the anaerobic microcosms may have been due to mercury sorption by the lucite columns used to fabricate the microcosms. Coyne and Collins (1972) found that up to 60 percent of the mercury in a 50 µg/l solution was lost to the walls of plastic containers within one hour. The anaerobic microcosms were the only ones that did not form an algae covering on the walls of

the microcosms; however, a thin bacterial layer formed (Table 20) but this may not have prevented sorption of mercury to the plastic. It seems that the algae mat that formed on the walls of the aerobic microcosms would have absorbed the mercury before it could be adsorbed by the plastic walls of the microcosm.

Based on data from Coyne and Collins (1972) an estimated average of 66 percent of the mercury would go to the plastic walls of the anaerobic microcosms whereas an average of 25 percent of the mercury would be found in the algal layers that formed on the aerobic microcosm walls.

The percent accountability of mercury varied with each lighting condition; but within each lighting condition, there was close agreement—Microcosms 3 and 4, 35 and 33 percent; Microcosms 7 and 8, 108 and 99 percent; Microcosms 11 and 12, 109 and 108

percent; and Microcosms 15 and 16, 84 and 85 percent. The variance in the percent accountability may have been due to problems associated with sampling and analysis as well as physical and chemical differences within the microcosms.

Within each core section, the mercury level could be expected to decrease slowly from the upper to the lower edge of the section. Each thawed section was mixed thoroughly and analyzed. The resultant mercury concentration was then an average for the particular core section studied.

The liquid media was not analyzed daily but rather at two week intervals. Thus, for the purposes of the mercury balance, an average daily effluent mercury concentration was used in the calculations.

An unknown amount of mercury was lost to the plastic walls of the microcosms. According to the

Table 21. Total mercury present in microcosms (μg).

	Microcosm							
	3	4	7	8	11	12	15	16
Sediment								
Depth (cm)								
0-1	696	792	1961	1785	2659	5300	1755	3281
1-3	533	173	2659	3734	2212	2063	1828	569
3-5	51	153	2745	635	581	239	447	141
5-10	98	118	157	55	78	147	147	118
> 10	-	-	-	-	-	-	-	-
Total Hg (Sed.)	1378	1236	7522	6209	5530	7749	4177	4109
Total Hg (Algae)	b	b	1581	879	4294	1640	2770	2942
Total Hg (H_2O)	1933	1866	1471	2640	831	1131	1075	1066
Total Hg (Microcosm)	3311	3102	10394	9548	10475	10340	8022	8117
% of Total Accounted For ^a	35	33	108	99	109	107	84	85

^aTotal Hg added = 9450 μg .

^bNo algae layer formed.

Table 22. Distribution of mercury in the microcosms (μg).

	Microcosm							
	3	4	7	8	11	12	15	16
% of Total in Sediment ^a	19	13	78	66	58	81	43	43
% of Total in Algae	b	b	16	9	45	17	29	31
% of Total in Water	20	19	15	28	9	12	11	11

^aTotal mercury added = 9450 μg .

^bNo algae layer formed.

mass balances, minimal amounts were absorbed in the lighted microcosms but appreciable amounts may have been absorbed by the plastic walls of the dark microcosms. The algae mat formed on the walls of the lighted microcosms early in the experimental period and thereby possibly prevented further sorption of mercury by the plastic walls of the microcosm.

Average values for the lighted microcosms from Table 22 show that the final mercury distribution over the period of study was: 62 percent in the sediments; 25 percent in the algae; and 14 percent in the water.

A comparison of Table 19 and Table 20 indicates that there is roughly a factor of 15 difference in mercury levels between upper sediment layers and algae mats. That is, an average of 223 $\mu\text{g Hg/gm}$ algae versus an average of 14 $\mu\text{g Hg/gm}$ sediment. It is obvious that both the algal material and sediments in the microcosms were an important sink for the influent inorganic mercury.

Mercury Uptake Rate

The mercury uptake rate was determined using Microcosm 16. The uptake rate is a measure of how fast mercury leaves the solution and is absorbed by the sediments or by the algae on the microcosm walls. It is an estimate of the exchange or turnover rate. A plot of C/C_0 vs. time allows the "k" value for the uptake rate equation to be determined (Figure 43).

$$C/C_0 = e^{-kt} \dots \dots \dots (1)$$

in which

C = mercury concentration at time t (mg/l)

C_0 = mercury concentration at time t = 0 (mg/l)

k = uptake rate constant

A plot on semilog paper yielded a straight line with $k = 0.009/\text{hr}$. The final equation is:

$$C/C_0 = e^{-0.009t} \dots \dots \dots (2)$$

The half-life of mercury in the water phase was calculated from Equation 2 and found to be 77.1 minutes.

The lower line on Figure 43 is a plot of the mercury in solution versus time, for centrifuged samples of water from Microcosm 16. The smaller slope indicated that the rate of removal of mercury from solution was slower for the centrifuged sample than for the sample that was not centrifuged. The inorganic mercury may form complexes with water or other constituents in the solution and these

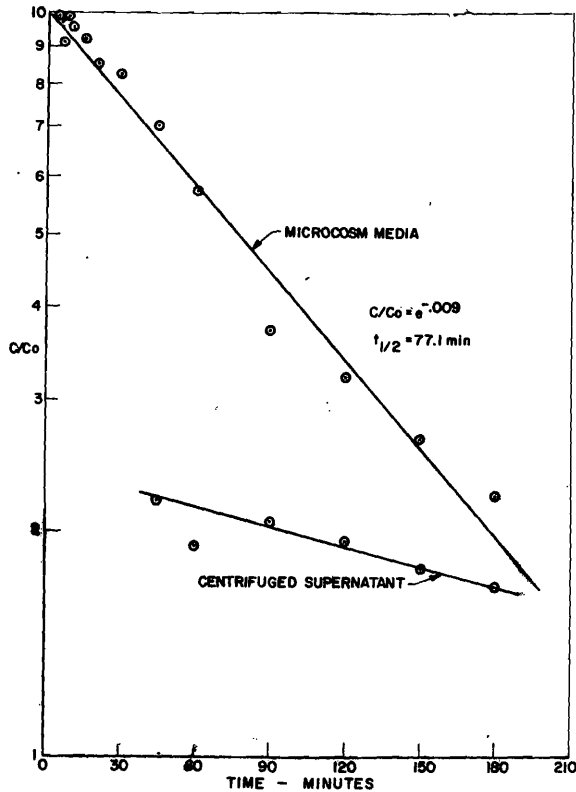

Figure 43. Mercury uptake rate.

complexes may inhibit the adsorption of mercury onto the surfaces of the sediments and algae mats. Complexes such as HgOH^+ , $\text{Hg}(\text{OH})_2$, and $\text{Hg}(\text{OH})_3^-$ are formed when the mercuric ion reacts with water and may have different rates of adsorption or may not be adsorbed at all.

Statistical Analysis

Multiple regression statistical analysis of the mercury concentrations in the microcosms related to several selected parameters were performed on the computer at the Utah Water Research Laboratory. After the completion of the experiment, it became apparent that the system was influenced by many parameters and that, perhaps, not all had been monitored during the course of the experiment. Therefore, only limited conclusions could be drawn from these experiments.

Correlations between variables of the water phase were not readily apparent because of the complexity of the system within the microcosms. The most important variable controlling mercury distribution within the microcosm was determined using multiple-regression analysis; however, no single parameter appeared to be controlling. Total mercury concentrations in the water phase were taken as the dependent variable (Appendix D, Table D-1) and

suspended solids (Appendix D, Table D-2), volatile suspended solids (Appendix D, Table D-3), and pH (Appendix D, Table D-4), were taken as the independent variables.

Table 23 lists the statistical information gained for the aqueous phase mercury. Columns 2 - 5 list the mean values for each parameter for the entire study period (189 days), mercury (mg/l), suspended solids (mg/l), volatile suspended solids (mg/l), and pH. Columns 6 - 8 list the correlation coefficients for each independent variable (water phase mercury). Columns 9 - 12 list the multiple-regression coefficients for total water-phase mercury (Bo) versus suspended solids (Bss), volatile suspended solids (Bvss), and pH (BpH). Column 13 contains the correlation coefficients from the multiple regression analysis. Finally, the most significant independent variable is listed in column 14 along with its value for the statistical t-test in column 15.

It appeared that the multiple regression coefficients of the aerobic microcosms for suspended solids (Bss) were negative for the microcosms in which nitrate nitrogen was absent in the nutrient media, and positive in the microcosms in which nitrogen was present in the nutrient media (Table 23). From this analysis mercury distributions were apparently affected most by pH although the presence of suspended material, principally organic, had a significant effect on the distribution.

Discussion of Mercury Results

The natural level of mercury in the Hyrum Reservoir sediments approximated soil levels indicating no buildup in the reservoir from natural concentrations of mercury in the reservoir watershed runoff. However, a buildup in the microcosm sediments occurred when the relatively high experimental

concentrations (50 µg/l) were used. Anaerobic conditions would tend to increase mercury in solution and available to higher levels of the food chain. Lighted conditions increased removal from the aqueous phase apparently from increased algae for uptake and from higher pH, resulting from the photosynthetic activity. Complete mass balances were obtained in lighted microcosms but not in the dark microcosms, incomplete assessment of outflow, wall absorption by the plastic, or other phase distributions were responsible.

The penetration of mercury into sediments exposed to overlying water containing mercury appears to be confined mostly to the upper few centimeters of sediment. The sediments in the microcosms were not disturbed by motile macro-fauna or plants larger than algae. At the end of the period of study (189 days), roughly 90 percent or more of the mercury in the sediments was found in the upper five centimeters of sediment. In general the mercury levels in the 1-3 centimeter sediment depth range were half of the mercury levels in the 0-1 centimeter depth range (Table 19). Applequist et al. (1972), found similar results when they studied sediment mercury distributions near municipal sewer outfalls in New Haven Harbor, Connecticut.

The production of gases by bacteria in the sediments may allow mercury to penetrate deeper into the sediments. As a result of bacterial action, gases were produced in the sediments. Eventually, sufficient quantities of gases were produced to form bubbles beneath the surface of the sediments. When the bubbles became so large that the sediments could no longer contain them, they escaped from the sediments. The resulting cavity collapsed, and allowed the overlying mercury-laden water to enter the cavity. By this means mercury could penetrate deeper into the sediment than if the sediment surface was not disturbed. This can only be taken as an observation

Table 23. Statistical analysis of total mercury in water.

Microcosm	Mean Values				Correlation Coefficients ^a			Multiple Regression Coefficients				Multiple Correlation Coefficient	Most Significant Independent Variable (t value)	
	Hg	SS	VSS	pH	SS	VSS	pH	Bo	Bss	Bvss	BpH			
1	2	3	4	5	6	7	8	9	10	11	12	13	14	15
3	8.70	1.50	1.09	6.65	-0.118	-0.090	0.421	179	-3.20	0.261	28.80	0.588	pH	(1.42)
4	9.59	2.74	1.64	6.66	-0.354	-0.030	0.029	-65.98	-3.90	6.23	11.40	0.639	VSS	(1.65)
7	8.86	16.99	4.32	9.16	0.350	<u>0.837^b</u>	-0.205	-96.50	-0.035	3.04	10.10	<u>0.895</u>	VSS	(3.34)
8	13.64	68.24	13.27	9.14	-0.295	-0.451	-0.037	53.10	0.15	-1.21	-3.66	0.540	VSS	(0.93)
11	4.31	12.57	2.95	9.35	-0.109	-0.067	0.214	-23.50	-0.13	0.98	2.84	0.344	pH	(0.67)
12	5.79	4.15	2.06	9.61	<u>+0.965</u>	<u>0.945</u>	0.412	-59.40	1.05	1.89	5.92	<u>0.991</u>	SS pH	(2.72) (2.75)
15	5.19	14.35	3.17	9.29	-0.386	0.426	-0.149	23.90	-0.22	2.25	-2.44	0.639	SS	(1.23)
16	5.55	3.06	1.62	9.60	-0.452	-0.699	0.514	-60.80	1.35	-3.41	7.06	<u>0.856</u>	VSS	(2.59)

^aMercury concentrations in water as a function of the listed independent variable.

^b"Best" correlation coefficients are underlined.

rather than a conclusion because of the many obvious differences between anaerobic and aerobic systems. The effects of the many different variables may more likely be synergistic rather than each variable acting independently to control the final distribution of mercury.

The pH of the water solutions may have had an effect on the distribution of mercury in the microcosms. The pH of the anaerobic microcosms was 6.6 on the average and roughly 20 percent of the mercury was found in the water. With the exception of Microcosm 8, which was much higher than the other microcosms in suspended solids, an average of 12 percent of the mercury was found in the water of the aerobic microcosms where the average pH was 9.3.

There was a difference by a factor of more than 15 between mercury concentrations in the sediment and algae mats (average of 14 $\mu\text{g Hg/g}$ dry sediment and 223 $\mu\text{g Hg/g}$ algae). Mercury has a strong affinity for organic material and the organic material of the algal mats may offer more active sites for adsorption than the sediments. Transfer into organic material and pH effects were significant factors controlling

mercury distribution. When nitrogen was added (as nitrate) there may have been more suspended matter (algal growth) which would account for the positive regression coefficient observed for suspended matter and mercury in water.

Because of the complexity of the system within the microcosms, correlations between variables in the water were not readily apparent. Volatile suspended solids, total suspended solids, and pH were considered as the variables that were most likely to influence mercury distribution within the microcosms. For each microcosm, multiple regression analyses were performed and a computer was used to determine the most important variable relating to mercury concentrations in the water and the resultant distribution of mercury within the microcosms. As can be seen from Table 23, none of the three variables studied appeared to be independently controlling mercury distribution within the microcosms. The lack of evidence for organomercury compounds is not definitive as analytical procedures did not appear satisfactory; so the reason for the lack of repetition of Langley's (1973) results cannot be determined. However, no loss of dimethylmercury could be shown (see Kolb et al., 1974).

RESULTS: PART V—IRON METABOLISM IN THE MICROCOSMS

Aqueous Chemistry of Iron

Biological organisms require a variety of nutrients to grow and maintain themselves; these nutrients (EPA, 1971) were supplied to the microcosms in the daily input medium (Table 5). The only other source of nutrients was from within the system itself and involved, principally, solubilization (by chemical or physical processes) from the sediments. Included among these nutrients are the very important trace elements, those constituents required by organisms in micro-quantities. Although not a variable in the experimental run of the microcosms, Fe will be discussed herein because of its importance as a possible growth rate limiting nutrient (Porcella et al., 1973; Goldman and Carter, 1965; Browne, 1942).

Iron is the second most abundant metal and the fourth most abundant element in the earth's crust (Cotton and Wilkinson, 1962). The source of Fe in the natural aqueous environment results from input of drainage basin waters and the constant interaction between the sediments and the water overlying the sediments. In these experiments chelated Fe was added daily ($\text{FeCl}_3 \cdot 6\text{H}_2\text{O}$) at a concentration of $33 \mu\text{g Fe/l}$ (an excess amount so Fe would not be a limiting nutrient); the hexadentate ligand used was Na_2EDTA , at a concentration of $300 \mu\text{g/l}$. This chelator was selected because it is a highly effective, very stable complexor, which forms strong 1:1 complexes with metal ions (Hanck and Dillard, 1973). Chelation of the metal ions is one mechanism used to keep Fe in solution and more available to the microorganisms than would otherwise be the case without such complexation. This is necessary due to the extremely limited solubility of Fe in natural systems. At the concentrations of Fe and chelator used in this experiment, all of the Fe was complexed, soluble and available for uptake by microorganisms (Stumm and Morgan, 1970). Competition for this chelator from Ca^{++} and Mg^{++} could decrease the tendency of Fe to form soluble complexes, but at the pH of the input medium, and the concentrations of major cations involved (22 mg Ca/l, 12 mg Mg/l), it was assumed that all the Fe formed soluble complexes with the EDTA (Stumm and Morgan, 1970).

The amount of Fe input to the system was overshadowed by the quantity of Fe found in the sediment phase of the microcosms. The initial concentration of Fe in the sediment (prior to incubation within the microcosms) was 2.2 percent total Fe (HClO_4 digestion), of which 0.02 percent was extractable Fe (0.005 M diethylenetriaminepentacetic acid extraction). In the sediments the total Fe was 10^6 and extractable Fe was 10^4 times the Fe added daily in the medium. Since Fe was not a variable in this experiment, any differences in productivity among the microcosms was considered to be due to the variables of light, $\text{NO}_3\text{-N}$, Hg, or any combination of these parameters. In order for Fe to be an important factor in this experiment, conditions would have to be such that the daily supply of Fe in the feed would have to be consumed or, as in the case of the sediment phase Fe, it would have to be made unavailable (by chemical or physical mechanisms) to the microorganisms.

Most natural systems have a pH which falls within a range of 6.5 - 8.5; at the experimental concentrations in the input medium ($5 \times 10^{-7} \text{ m}$) unchelated Fe would be present under these pH conditions as the hydrated ions of Fe(II) and Fe(III), the hydroxides $\text{Fe}(\text{OH})_2$ and $\text{Fe}(\text{OH})_3$, the carbonate FeCO_3 , or any one of a number of hydroxide complexes, the most prevalent being $\text{Fe}(\text{OH})_3^-$, $\text{Fe}(\text{OH})_2^+$ and $\text{Fe}(\text{OH})_4^-$. These are shown in the phase diagrams in Figures 44 and 45 (Stumm and Morgan, 1970).

$\text{Fe}(\text{OH})_3$ would dominate the solubility of Fe(III). At pH ranges found in nature (and those found in the microcosms) the free Fe^{+++} concentration is considered negligible; instead, trivalent Fe exists as hydroxo complexes, chelated to some organic molecule or as a part of a viable or a dead microorganism (Figure 46) (Theis and Singer, 1974).

The Fe-P relationship (complexation and interaction) also affects, to a great extent, the concentrations of both elements in the aqueous phase of any aquatic habitat; this will be discussed later.

FeCO_3 dominates Fe(II) solubility at $\text{pH} < 11$, indicating that the carbonate equilibrium plays an

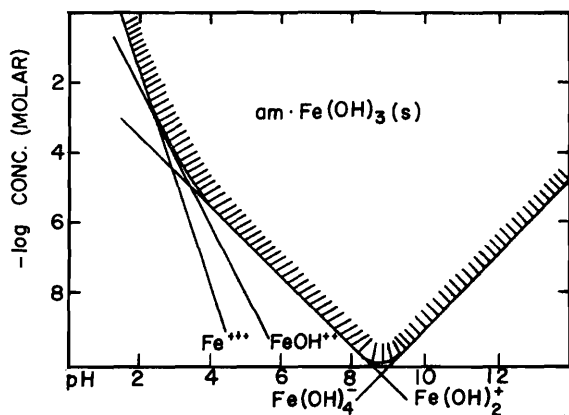

Figure 44. Phase diagram for the solubility of Fe(III) in natural aquatic systems (Stumm and Morgan, 1970).

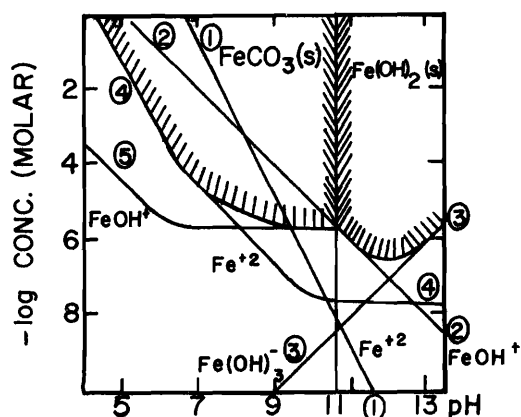

Figure 45. Phase diagram for the solubility of Fe(II) in natural aquatic systems (Stumm and Morgan, 1970).

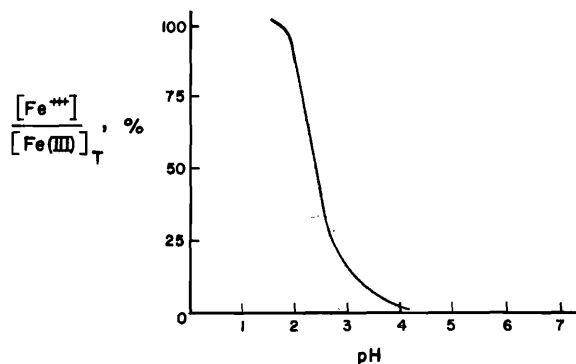

Figure 46. Percent of total Fe which is free Fe(III), as a function of pH (Theis and Singer, 1974).

important role in regulating the solubility of divalent Fe. The molar solubility of FeCO_3 is 4.5×10^{-6} which would place Fe^{++} in solution to a concentration of $250 \mu\text{g Fe/l}$; thus, Fe under these reducing conditions would be relatively soluble. It must be pointed out that in most natural aquatic habitats, Fe(II) exists in significant concentrations only under anaerobic conditions (Brock, 1970).

In ferrous-ferric aqueous systems, it is the pH, the redox potential, and the complexing ligands which dictate the composition and the stability of the Fe oxidation states (Cotton and Wilkinson, 1962). In strictly anaerobic conditions one would expect Fe(II) to predominate, while under natural aerobic conditions, oxidation would occur and Fe(III) would dominate. However, organic matter being present, Fe(II)-organic complexes and Fe(III)-organic complexes exist (Figure 47). The former are resistant to oxidation under aerobic conditions and the latter are resistant to reduction under anaerobic conditions (Theis and Singer, 1974). It is possible to have appreciable amounts of Fe(II) under aerobic conditions and Fe(III) under anaerobic conditions when organics are present.

Lighted Microcosms

The lighted microcosms were under high oxidizing and pH conditions (11-14 mg/l DO and 8.0-10.0 pH range); these conditions would favor Fe(III), considering the supersaturated DO levels (reaction 1, Figure 47). Fe(II) in its free ionic state (Fe^{++}) does not exist and therefore FeCO_3 is not a controlling factor in the Fe equilibrium. One can isolate the Fe^{+++} and Fe^{++} lines from Figures 44 and 45 to show the effects of increased OH^- concentrations on the ionic forms of iron (Figure 48).

Using the master variable of pH, we can conclude that, Fe(III) in its free ionic state (Fe^{+++}) is essentially absent; this is obvious, since at pH 8-10, there is more than enough OH^- to precipitate Fe^{+++} out of solution as Fe(OH)_3 , due to its extremely limited solubility ($\text{pk}_{\text{sp}} = 38.7$ (Figure 44)).

Any Fe(III) present, hydrolyzes (Theis and Singer, 1973) to the stable trivalent Fe-hydroxo complexes. These Fe-hydroxo complexes are chemically resistant to reduction by organic matter (Theis and Singer, 1974).

Since Fe is added in the trivalent state, the only source of Fe(II) in this oxygen supersaturated system would be from the degradation of Fe(III)-organic complexes (Figure 47, reaction 2). Fe(II) thus formed could combine with unoxidized organic matter to form stable Fe(II) organic complexes. Some of the Fe(II) formed would also be susceptible to oxidation and deposition:

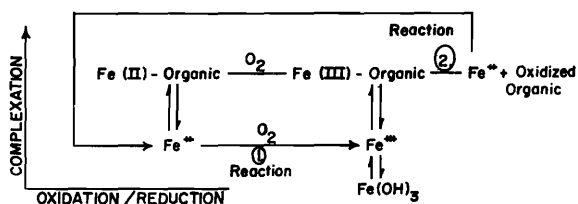

Figure 47. Fe in presence of organic matter and oxygen. A simplified schematic by Theis and Singer (1974) to show Fe(II) and Fe(III) in natural water systems.

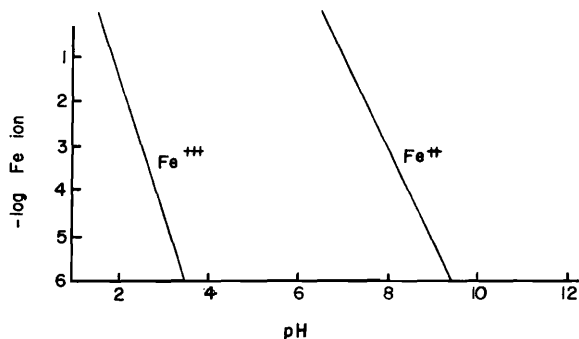
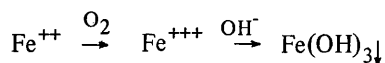

Figure 48. Solubility of Fe ion in equilibrium with solid oxides or hydroxides.



The rate of these reactions would be rapid and a function of the partial pressure of O_2 and the concentrations of $[\text{Fe}(\text{II})]$ and $[\text{OH}^-]$ (Stumm and Lee, 1961):

$$-\frac{d[\text{Fe}(\text{II})]}{dt} = k [\text{Fe}(\text{II})] (\text{P}_{\text{O}_2}) [\text{OH}^-]^2$$

Considering this rapid oxidation, Fe(II) would have to be complexed and stabilized by organic matter to be present in aerobic systems.

Physical and chemical conditions were such, in the lighted microcosms, that it was impossible for Fe(II) to migrate from the sediments and enter the aqueous phase. Anaerobic conditions existed just below the surface of the mud. Fe^{+++} would be reduced to Fe^{++} and thus be soluble; yet, Fe would still not reach the aqueous phase because as soon as the reduced form crossed the liquid-solid interface into O_2 supersaturated waters it would be oxidized and reprecipitated as $\text{Fe}(\text{OH})_3$. (The aqueous phase of the system was completely mixed thus eliminating DO stratification and consequent anaerobic hypolimnion.)

Algal growth did occur in the light microcosms, and the growth was predominantly on the walls of the unit (periphyton). Any Fe taken up by these microorganisms would be removed from the aqueous phase; this Fe would probably be of the Fe-organic complex form.

It must be concluded that the Fe found in the aqueous phase would consist of Fe(III)-organic and Fe(II)-organic (both particulate and soluble) any suspended $\text{Fe}(\text{OH})_3$ precipitate and Fe(III) hydroxo complexes.

Dark Microcosms

Under the reducing conditions of the dark microcosms (0.5-0.9 mg/l DO and 6.5-7.0 pH range), both DO and pH levels favored Fe(II). Because Fe was added in the trivalent state, Fe could be complexed in that state (III) by organic matter and thus remain in solution as Fe(III)-organic despite reducing conditions. The particulate organic matter in the dark (VSS = 1.09 mg/l) was small as compared to that in the light microcosms (VSS = 6.24 mg/l), yet because there was some particulate organic matter present, the Fe(III)-organic could be formed. This was also substantiated when examining the soluble organic carbon data; the dark (2.4 mg C/l) effluent had slightly less than the light (3.2 mg C/l) effluent, but there was still sufficient organic material to form the trivalent Fe complexes. Because of this organic material being present, Fe(II)-organic would also be formed.

The most prevalent Fe species present would be the divalent inorganic: Hydrated $\text{Fe}(\text{H}_2\text{O})_x^{++}$ and Fe(II)-hydroxo complexes. The Fe data presented below are for total unfiltered samples (particulate plus soluble). Any reference to total soluble Fe would be based on Whatman GF/C filtered samples.

Results and Discussion of Iron Distributions in Microcosms

Covariant analysis of the Fe data (Table 9) showed that higher total Fe concentrations existed in the dark effluent (0.131 mg Fe/l) than in the light effluent (0.092 mg Fe/l). If the data from Microcosms 6, 8, and 9 (typical microcosms having high turbidity and/or low wall growth) is omitted, the average effluent total Fe concentration would be even less, 0.052 mg Fe/l. The bathophenanthroline analysis (Strickland and Parsons, 1968) for Fe in the aqueous phase was found to be of sufficient sensitivity to detect differences between the light and dark microcosms. Samples were acidified, buffered, reduced and allowed to react with bathophenanthroline; the analyses were sensitive to $\geq 10 \mu\text{g Fe/l}$.

The fact that the dark microcosm effluent was higher in Fe was expected because:

1. Conditions of light microcosms favored deposition of Fe onto the sediments.
2. Fe uptake by microcosms in the light was predominantly by the periphyton, which did not show up in the effluent.
3. Dark microcosm conditions of low pH and low DO favored Fe solubility as Fe(II).

Fe in the dark microcosm effluent had a higher fraction which was soluble (64 percent soluble) than the Fe in the light effluent (29 percent soluble). This was in accordance with expectations because:

1. The dark microcosm effluent Fe was inorganic and soluble (Fe^{++} , hydrated $\text{Fe}(\text{H}_2\text{O})_x^{++}$ and Fe^{++} -hydroxo complexes) with only some Fe(II)-organic and Fe(III)-organic; a portion of the organically complexed Fe also being soluble.
2. The light microcosm effluent Fe was associated with organic matter, with a portion of the particulate fraction undoubtedly being the suspended inorganic precipitate $\text{Fe}(\text{OH})_3$.

The particulate fraction is defined as that portion of the sample which would be retained upon a glass fiber filter Whatman (GF/C). Analytical technique was unable to differentiate between organic and inorganic (precipitate) particulate.

Fe, under natural conditions, not only exerts a profound effect upon biological systems, but it plays a major role in controlling the distribution of phosphorus between the solid (sediment) and liquid (aqueous) phases (Stumm and Morgan, 1970). Fe and P are sometimes found in nature in comparable concentrations, and any extensive complex formation involving Fe and P would have a significant effect upon the distribution of Fe, P, or both. The daily addition of phosphorus as K_2HPO_4 at a concentration of 93 $\mu\text{g P/l}$ was in excess to prevent it being a limiting nutrient (EPA, 1971). That concentration of phosphorus approximated the summer time average input to the Hyrum Reservoir (Luce, 1974).

Covariant analysis indicated that the total P concentration was significantly higher in the dark effluent (0.235 mg P/l) than in the light effluent (0.091 mg P/l). If the data from Microcosms 6, 8, and

9 of the light units were to be omitted, the average effluent concentration would be 0.048 mg P/l. P follows almost exactly the same pattern as seen with Fe; the much lower P concentrations in the light effluent were apparently due to the fact that:

1. P complexes with Fe and precipitates out of solution and onto the sediments (pK_{sp} of FePO_4 is 23).
2. P is taken up by the periphyton and thus removed from the aqueous phase.
3. P forms insoluble compounds with other elements and drops out of solution (least likely).

As with the case of Fe, the fraction of total P which is soluble is much higher in the dark microcosms (74 percent) than in the light microcosms (27 percent). In the dark effluent, essentially all of the soluble total P was inorganic (97 percent orthophosphate). In the light effluent, the P (again as was the case with Fe) was associated mostly with the particulate phase.

Considering the light microcosms only, no definite pattern of Fe and/or P could be attributed specifically to one of the variables ($\text{NO}_3\text{-N}$, Hg, or lighting scheme). The only apparent pattern seemed to be the equal effluent concentrations of Fe and P. The effluent total Fe concentration was significantly higher in Microcosms 6, 8, and 9 (0.176, 0.204, 0.260 mg Fe/l) than the average of all other light units (0.052 mg Fe/l); the effluent total P concentrations (0.172, 0.210, 0.280 mg P/l) were also higher than the average of the other light units (0.048 mg P/l). The consistent relationship (Figure 49) between total Fe and total P in the lighted microcosms indicated interaction between these elements; it should be noted that the ratio of P/Fe in the input media was 2.8:1. Since a large portion of Fe and P was particulate (73 percent), we examined the particulate phase and an approximate one to one relationship still held (Figure 50). Because of the high productivity of the light units, it must be concluded that the causes for these similar mechanisms for distribution of Fe and P were primarily biologically instigated (rather than chemically or physically motivated).

The other phases (dark:total, particulate, soluble; and light:soluble) exhibited different patterns of distribution (Figure 51), with Fe found at higher concentrations than P. The dark particulate P and Fe data were scattered, while the dark:total and soluble and the light:soluble had P/Fe ratios of 1/2.

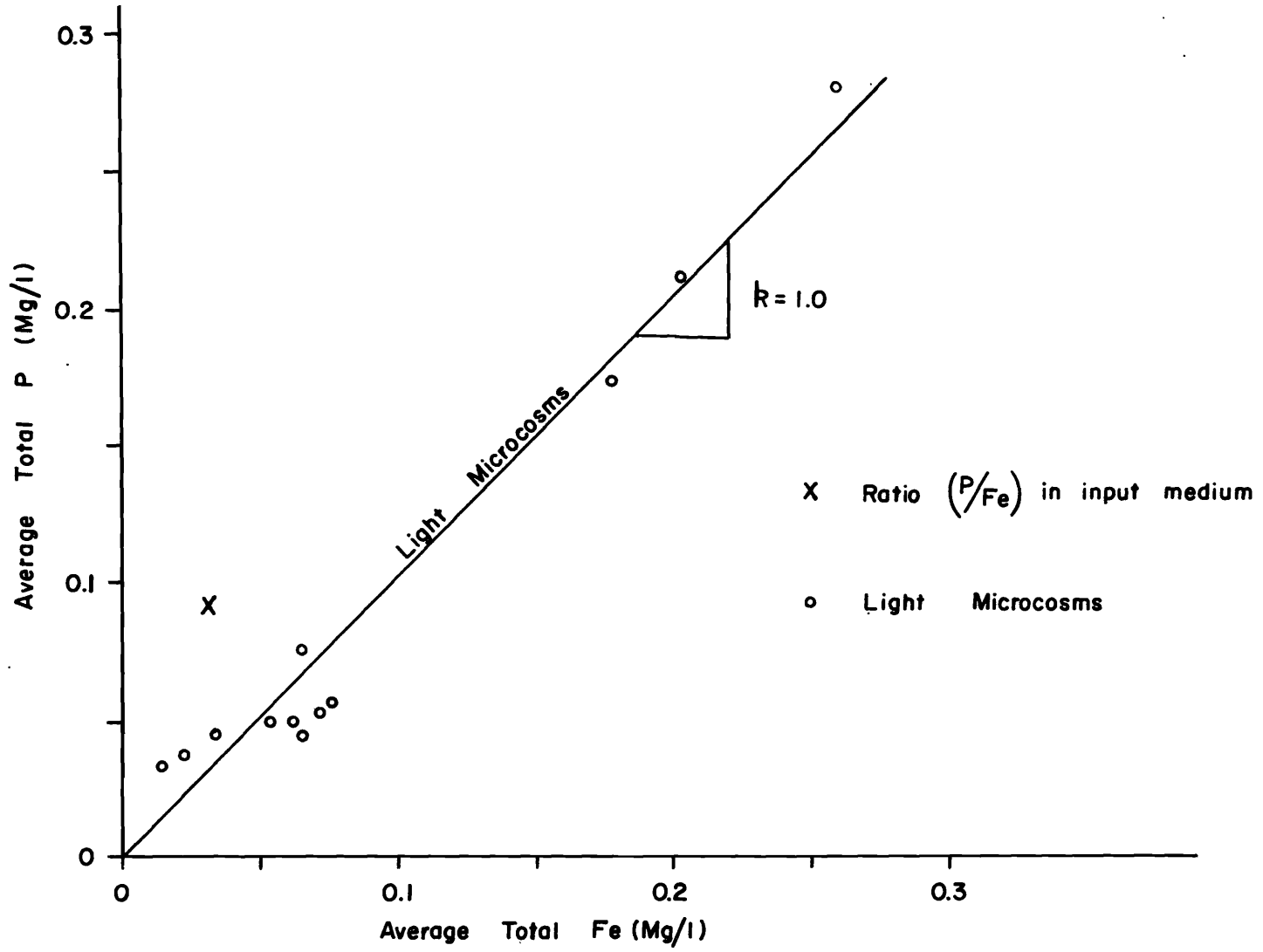

Figure 49. Relationship of total phosphorus and total iron in the light microcosms.

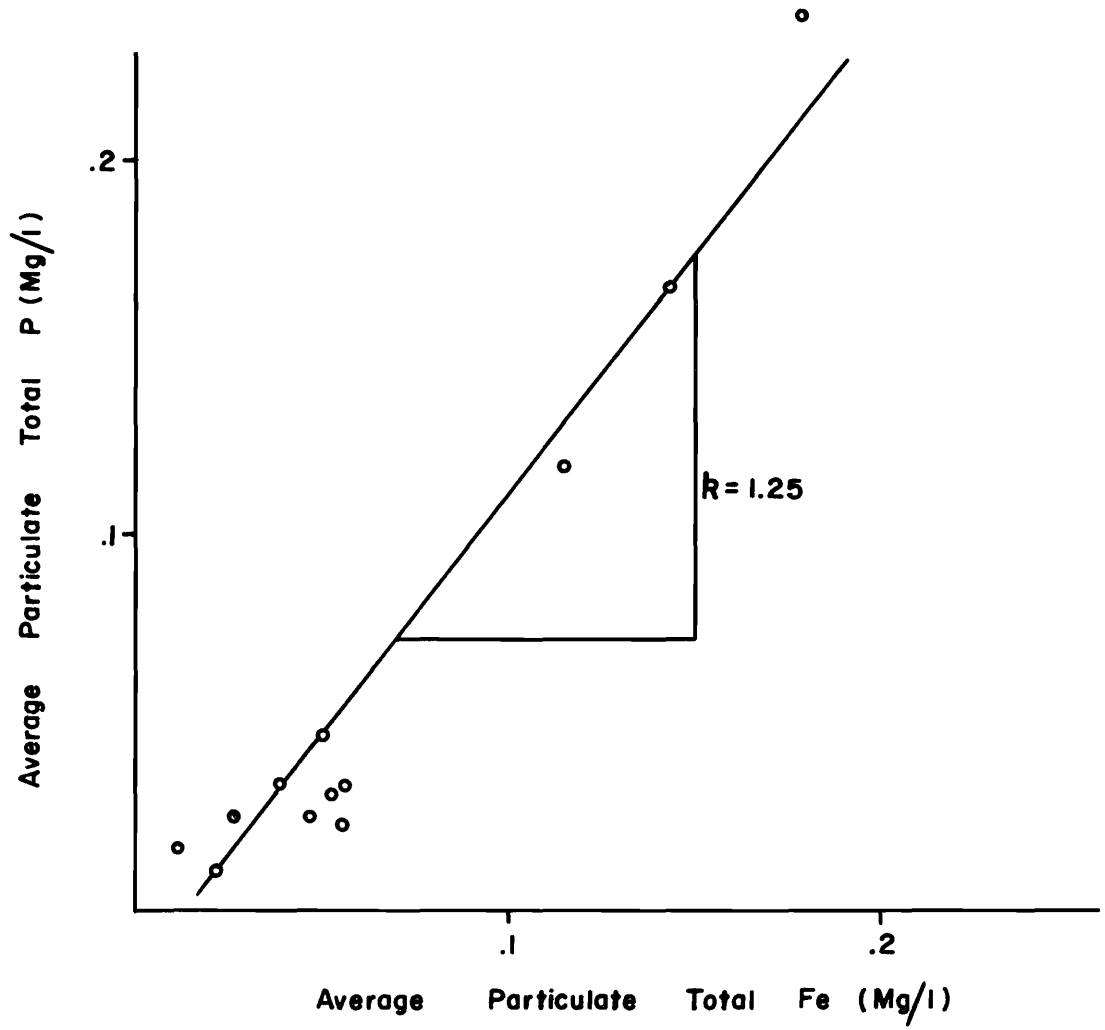

Figure 50. Relationship of particulate phosphorus and iron of the light microcosms.

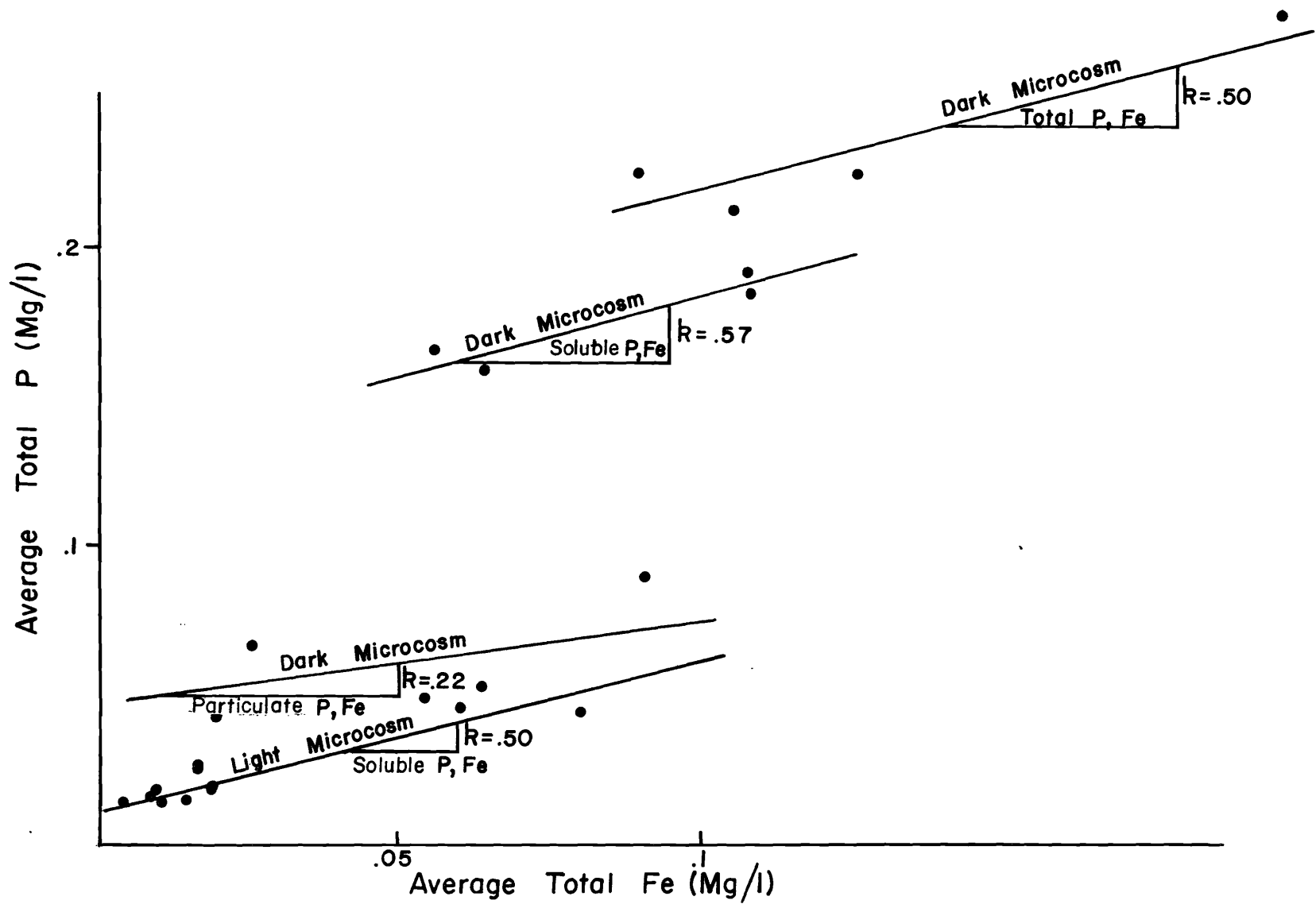

Figure 51. Relationship between phosphorus and iron which did not exhibit distribution.

DISCUSSION

Aquatic microecosystems (microcosms) have been used to make measurements, perform bioassays, or develop information about aquatic processes. Because these systems are under controlled conditions, they allow characterization of specific processes and mineral or organic cyclings which could not be easily discerned in the field. Microcosms come in every shape and form and uses of resultant information usually define how complete and complex specific microcosms are. The microcosms in this report were designed to allow complete chemical balances of important elements in microbially dominated sediment water systems.

Gas production in terms of quantity and composition showed the greatest responses to the major variation of dark and lighted microcosms. Also gas production seemed to be an excellent indicator of respiration and productivity as a function of organic matter in sediments and nutrient supply. Thus, the quantity and composition of gases produced in natural lake sediments under field conditions could be used as an indicator of trophic status as well as level of organic degradation. For example, specific gases such as methane, ethylene, and other hydrocarbons might indicate the presence of specific microorganisms and processes (Dowdell et al., 1972; Gibson, 1964; Smith and Restall, 1971). In other cases sediment laden with heavy metals and resultant toxicity might prevent gas metabolism which would normally be expected given a high nutrient and organic content.

Another important aspect of the microcosm study was the significance of nitrogen fixation. In a strict sense in these systems, nitrogen apparently could not be made limiting because algal communities would develop which were dominated by blue-green nitrogen fixers (*Anabaena*) and which would fix sufficient nitrogen to ensure that some other factor became limiting. Thus, as has occurred in lakes (e.g., Clear Lake, Horne and Goldman, 1972), and would

be expected to occur, the system will satisfy a nitrogen requirement so long as other factors are in relative abundance.

The importance of mercury added at low levels over long periods of time was difficult to assess. It seemed likely that concentrations similar to the experimental ones would have to be discharged to a receiving water for longer period of time than six months in order to observe toxic effects. The inability to demonstrate organomercuricals in the sediment system is not definitive since that could have resulted from poor analytical techniques.

Iron and phosphorus interactions confirmed literature results, that iron and phosphorus dynamics are intimately linked (Wildung and Schmidt, 1973; Fitzgerald and Uttonmark, 1974; Fillos and Swanson, 1975; Mortimer, 1941, 1942; Hwang et al., 1975; Syers et al., 1973). In anaerobic sediments the availability of sediment iron may be sufficient to always meet the needs of productivity even though many factors serve to limit its availability; this is because extremely low concentrations are required for algal growth.

The need to understand carbon (Goldman et al., 1972; Kerr et al., 1973), nitrogen (Keeney, 1973; Patrick, 1973) and phosphorus cycles (Syers et al., 1973) in natural aquatic systems arises from the ubiquity of sources in natural ecosystems, their possible role as limiting factors, and the need for adequate control mechanisms. That sediments act as a source of phosphorus (e.g., Porcella et al., 1970), the only element that so far has an indication of being controlled in lakes and reservoirs (e.g., see Edmundson, 1972; Porcella et al., 1972, for phosphorus; this paper for nitrogen; Schmidler and Fee, 1974, for carbon) indicate the importance of evaluating sediments in terms of time and quantity in acting as a source for eutrophication problems.

CONCLUSIONS

1. The following gases were detected in the microcosms: N_2 , CO_2 , O_2 , CH_4 , $CH_2 = CH_2$, H_2S . H_2S was too low in concentration to be detected except by its odor.
2. In the dark microcosms O_2 was rapidly utilized so that near anaerobic conditions existed in the overlying water and atmosphere of the microcosms (partial pressure = 0.03) as well as in the sediments.
3. Mass balances of gases around the sediment-water system of the microcosms indicated that:
 - a) Nitrogen gas dynamics were not affected appreciably by nitrogen fixation; an acid spill great enough to upset the bicarbonate buffer system and to acidify bicarbonates in the sediments produced so much CO_2 that it sparged N_2 from the aqueous phase.
 - b) Oxygen gas dynamics were especially responsive to benthic oxygen demand in the dark microcosms ($> 300 \text{ mg } O_2/m^2$ day) and photosynthesis resulted in considerable oxygen input to the atmosphere in the lighted microcosms; partial pressures of 40-45 percent oxygen were observed in some cases.
 - c) CO_2 dynamics resulted in a pH range of about 6.5 to 7.0 in the dark microcosms and generally 9.5 to 10.0 in the lighted microcosms.
 - d) Methane production occurred in all microcosms after 40 days and apparently resulted from methanogenesis in the sediments. Thus sediments remained anaerobic even in the highly productive light microcosms. Methane utilization by water column bacteria may have been responsible for the observation that the lighted microcosms produced less methane than the dark microcosms.
 - e) Ethylene ($CH_2=CH_2$) production was not observed until late in the study (≥ 80 days of operation) and was detected only in Microcosms 1, 2, 3, 4, 5, 6, 8, 9, 10, 13, 15, 16. Highest concentrations were observed in the dark microcosms. Water column utilization of the ethylene by photosynthetic organisms probably resulted in its disappearance.
4. Dissolved oxygen dynamics in lighted microcosms indicated that almost all the CO_2 was utilized driving the pH to 10 and lowering total dissolved inorganic carbon to values of 1 mg/l and less. Thus the microcosms were limited by pH or CO_2 or as has been suggested by Goldman et al. (1974) by other effects of high pH.
5. Nitrogen output from sediments is apparently limited and has an insignificant effect on sediment nitrogen even though it may have a significant impact on the algal community. Nitrogen input to the sediments is appreciable and occurs in the upper layers primarily. Highest sediment concentrations were observed in 0 - 1 cm layer but sediment mixing (from gas bubble release) must have occurred because typically the 1-5 cm layer had higher concentrations than the 5-15 cm layer.
6. Nitrogen fixation (acetylene-ethylene) was observed to occur only in the lighted microcosms indicating involvement of blue-green nitrogen fixers. Significant populations of *Anabaena* in the wall growth indicated the probable source of the fixation. All but one (Number 6) lighted microcosm had significant fixation; values ranged from 0.03 to 0.30 mg/microcosm day.
7. Nitrogen fixation was adequate to produce enough nitrogen for photosynthesis in all cases except Microcosm 6 where nitrogen fixers were apparently not present. Microcosms receiving no influent nitrate nitrogen produced essentially as much oxygen as those which did receive an input. Thus fixation was adequate to make up the nitrogen requirement so that some other factor was limiting algal growth.
8. Nitrogen fixation accounted for 12 percent of the nitrogen influent budget in the no nitrogen lighted microcosms and 5 percent in the plus nitrogen lighted microcosms. These are not especially unreasonable values in comparison to some highly eutrophic lakes.
9. Nitrogen fixation could not be observed by the analysis of gas phase nitrogen.
10. Denitrification occurred in the plus nitrogen dark microcosms.
11. Nitrification could not be substantiated.
12. Mercury concentrations had no apparent effects on nitrogen cycling.

13. Mercury was accumulated in the upper sediment layers. Baseline mercury in sediments were typical of values found in the surrounding soil systems and the lower (5-15 cm depths) sediment layers in the microcosms remained at these baseline values.
14. The high mercury levels in the upper sediment layers were apparently associated with organic matter; wall scrapings averaged 223 $\mu\text{g Hg/gm}$ dry weight ("algae") while sediments averaged 14 $\mu\text{g Hg/gm}$ dry weight sediments in the 0-1 cm layer of the lighted microcosms. Sediment mixing (probably by gas bubbles) seemed responsible for distribution of mercury (and probably nitrogen) down to a depth of 5 cm; values as high as 7 $\mu\text{g Hg/gm}$ dry weight of sediment were observed. Some redistribution of mercury occurred even in the no mercury microcosms; gas bubble mixing might cause less dense material such as organic matter to accumulate in upper sediment layers and thus carry mercury with it.
15. The penetration of mercury into sediments exposed to mercury laden overlying waters, appeared to be about five centimeters as about 90 percent or more of the sediment mercury could be found in the upper five centimeters of sediment.
16. In general, the mercury levels in the 1-3 cm sediment depth range were roughly one-half of the levels in the 0-1 cm range.
17. The sediments of the anaerobic microcosms had lower mercury levels than the sediments of the aerobic microcosms.
18. Of the inorganic mercury added (9450 μg) to each microcosm, approximately 62 percent went to the sediments, 25 percent to the aufwuchs, and 14 percent remained in the water.
19. There was a factor of more than 15:1 between the total mercury levels in sediment and algae. There was an average of 223 $\mu\text{g Hg/gm}$ algae and 14 $\mu\text{g Hg/gm}$ dry sediment, indicating the higher capacity of organic matter for mercury. Thus biological growth is the more likely transfer route for mercury in aquatic environments.
20. The anaerobic microcosms did not form algal coverings on the walls of the microcosms. Thus mercury in the anaerobic microcosms did not have a high biological accumulation of mercury and did not accumulate much mercury.
21. The plastic walls of the microcosms may have competed for mercury with algal mats that formed on the walls. No data were taken to confirm this possibility. Mass balances of mercury seemed adequate for the lighted microcosms (84 - 109 percent input accounted for) and indicated that wall sorption was minimal but dark microcosms did not balance (33 - 35 percent). No dimethyl mercury was detected in the gas phase. Also no dimethyl mercury nor monomethyl mercury could be detected in aqueous or sediment phases; detection problems may have been responsible for not seeing organomercuricals.
22. The pH of the water solution appeared to have an effect on the mercury distribution. Microcosms 3 and 4 were anaerobic and slightly acidic. Roughly, 20 percent of the mercury was found in the water of the anaerobic microcosms; this was compared to an average of 14 percent of the mercury that was found in the water of the aerobic microcosms.
23. The total suspended solids concentration affected the mercury concentration of the water. The average suspended solids of Microcosm 8 was 68 mg/l and the average suspended solids of all the other aerobic microcosms was about 8 mg/l. In Microcosm 8, 28 percent of the mercury was found in the water and in the other aerobic microcosms, an average of 14 percent of the mercury was found in the water. The anaerobic microcosms had lower suspended solids because there was essentially no primary productivity in the dark. The lower pH from anaerobic action in those systems accounted for the higher phase mercury.
24. Mercury is readily absorbed by sediments, suspended solids, and algae, from water solutions. A turnover half-time of 77.1 minutes for mercury in the water in the microcosms was found using labeled ^{203}Hg .
25. Because of the complexity of the system within the microcosms, correlations between mercury and variables of the water phase were not readily apparent. No single parameter appeared to be controlling overall mercury distribution.
26. Organic iron and iron-phosphorus interactions controlled iron and phosphorus availability. These elements were in considerable excess relative to photosynthetic needs.
27. The microcosm approach is an excellent means for identifying parameters and interactions in sediment-water systems. Gas analysis, nitrogen fixation, DO/CO_2 interactions and nutrient cycling (carbon, nitrogen, phosphorus, and iron) were all major factors involved in respiration and photosynthetic activity in dark and light microcosms.

REFERENCES

- Abbott, W. 1967. Microcosm studies on estuarine waters. II. The effects of single doses of nitrate and phosphate. *Jour. WPCF* 39:113-122.
- Alexander, M. 1965. Nitrification. *Agron.* 10:307-343.
- Andrews, J. F., R. D. Cole, and E. A. Pearson. 1964. Kinetics and characteristics of multistage methane fermentations. SERL Report No. 64-11, University of California, Berkeley. 180 p.
- Anonymous. 1971a. Mercury in the air. *Environment* 13(4):24-33.
- Anonymous. 1971b. Mercury in the air. *Science News* 99:280.
- APHA. 1971. Standard methods for the examination of water and wastewater. 13th Edition. APHA, N.Y. 874 p.
- Applequist, M., A. Katy, and K. Turekian. 1972. Distribution of mercury in the sediments of New Haven Harbor (Connecticut). *Environmental Science and Technology* 6:1123-1124.
- Austin, E. R. 1970. The release of nitrogenous compounds from lake sediments. M.S. Thesis, Water Chem. Program, University of Wisconsin, Madison.
- Austin, Elizabeth R., and G. F. Lee. 1973. Nitrogen release from lake sediments. *Jour. WPCF* 45:870-879.
- Bakir, F., S. DamLuji, and L. Amin-zaki. 1973. Methylmercury poisoning in Iraq. *Science* 181:230-242.
- Baumann, E. W. 1974. Determination of ppb sulfide in water with sulfide-selective electrode. *Anal. Chem.* 46:1345-1347.
- Bremner, J. M. 1967. Nitrogenous compounds. In: *Soil Biochemistry*, A. D. McLaren and G. H. Peterson (eds.). Marcel Dekker, N.Y., pp. 19-66.
- Brezonik, P. L., and G. F. Lee. 1968. Denitrification as a nitrogen sink in Lake Mendota, Wisconsin. *Environ. Sci. Technol.* 2:120-125.
- Brock, T. D. 1970. *Biology of microcosms*. Prentice-Hall. 737 p.
- Browne, C. A. 1942. Liebig and the law of the minimum. *Publ. Amer. Assoc. Adv. Sci.* 16:71-82.
- Bull, H. 1964. *An introduction to physical biochemistry*. F. A. Davis Co., Philadelphia. p. 21.
- Carr, R., and P. Wikniss. 1973. Short term storage of natural waters. *Environmental Science and Technology* 7(1):62-63, January.
- Chen, R. L.; D. R. Keeney, and J. G. Konrad. 1972. Nitrification in sediments of selected Wisconsin lakes 1:151-154.
- Coleman Instruments Division. 1972. MAS-50 mercury analyzer operating instructions. The Perkin-Elmer Corporation, Maywood, Illinois.
- Cotton, F. A., and G. Wilkinson. 1962. *Advanced inorganic chemistry*. 959 p.
- Cowan, P. A., and D. B. Porcella. 1973. Water quality analysis laboratory procedures syllabus. Utah Water Research Laboratory, Utah State University, Logan. Unnumbered.
- Coyne, R., and J. Collins. 1972. Loss of mercury from water during storage. *Analytical Chemistry* 44(6):1093-1096, May.
- Dowdell, R. J., K. A. Smith, R. Crees, and S. W. F. Restall. 1972. Field studies of ethylene in the soil atmosphere—equipment and preliminary results. *Soil Biol. Biochem.*, 4:325-331.
- Drury, D. D., D. B. Porcella, and R. A. Gearheart. 1975. The effects of artificial destratification on the water quality and microbial populations of Hyrum Reservoir. Utah Water Research Laboratory PRJEW011-1, Utah State University, Logan.
- Dugdale, R. C., and J. J. Doering. 1967. Uptake of new and regenerate nitrogen in primary productivity. *Limnol. Oceanogr.* 12:196-206.
- Dugdale, V. A., and R. C. Dugdale. 1965. Nitrogen metabolism in lakes: III. Tracer studies of the assimilation of inorganic nitrogen sources. *Limnol. Oceanogr.* 10:53-57.
- Environmental Protection Agency. 1971. *Algal assay procedures: Bottle test*. National Eutrophication Research Program, Corvallis, Oregon. 82 p.
- Environmental Protection Agency. 1972. *Methylmercury in sediment-provisional method*. EPA, April.
- Environmental Protection Agency. 1975. *Mercury in water (manual cold vapor technique)*. STORET No. Total 71900. Personal communication, Roy Gunnell, USGS, Salt Lake City, Utah.
- Feick, G., E. Johanson, and D. Yeaple. 1972. Control of mercury contamination in freshwater sediments. *EPA-R2-72-077*. 156 p.
- Flett, R. J., J. W. M. Rudd, and R. D. Hamilton. 1975. Acetylene reduction assays for nitrogen fixation in freshwaters: A note of caution. *Applied Microb.* 29:580-583.

- Fillos, J., and A. H. Molof. 1972. Effect of benthal deposits on oxygen and nutrient economy of flowing waters. *Jour. WPCF* 44:644-662.
- Fillos, J., and W. B. Swanson. 1975. The release rate of nutrients from river and lake sediments. *Jour. WPCF* 47:1032-1042.
- Fitzgerald, G. P., and P. D. Uttormark. 1974. Applications of growth and sorption algal assays. EPA-660/3-73-023, Superintendent of Documents. 176 p.
- Gahler, A. R. 1969. Sediment-water nutrient interchange. Proceedings of Eutrophication-Biostimulation Assessment Workshop, Middlebrooks et al., ed., University of California, Berkeley, California, pp. 243-257.
- Gibson, M. S. 1964. Organic acids as sources of carbon for ethylene production. *Nature* 202:902-903.
- Gill, J. 1975. Destratification effects on Hyrum Reservoir: Iron distributions. Unpublished M.S. Thesis, Utah State University. In preparation.
- Goering, J. J., and V. A. Dugdale. 1966. *Limnol. Oceanogr.* 11:113-117.
- Goering, J. J., and J. C. Neess. 1964. Nitrogen fixation in two Wisconsin lakes. *Limnol. Oceanogr.* 9:530-539.
- Goldman, C. R., and R. C. Carter. 1965. An investigation by rapid carbon-14 bioassay of factors affecting the cultural eutrophication of Lake Tahoe, California-Nevada. *Jour. WPCF* 37:1044-1059.
- Goldman, J. C., W. J. Oswald, and D. Jenkins. 1974. The kinetics of inorganic carbon limited algal growth. *Jour. WPCF* 46:554-574.
- Goldman, J. C., D. B. Porcella, E. J. Middlebrooks, and D. F. Toerien. 1972. Review paper: The effect of carbon on algal growth—its relationship to eutrophication. *Water Research* 6:637-679.
- Goldwater, L. 1971. Mercury in the environment. *Scientific American* 225:15-21.
- Grant, N. 1971. Mercury in man. *Environment* 13(4):3-15.
- Green, K. M. 1971. Investigations into the microbial ecology and limnology of Hyrum, in northern Utah. M.S. Thesis, Utah State University, Logan.
- Hanck, Kenneth W., and J. W. Dillard. 1973. Determination of the complexing capacity of natural waters. Water Resources Research Institute, University of North Carolina, Report No. 85. 73 p. December.
- Hardy, R. W. F., R. C. Burns, and R. D. Holsten. 1973. Applications of the acetylene-ethylene assay for measurement of nitrogen fixation. *Soil Biol. Biochem.* 5:47-81.
- Hatch, R., and W. Ott. 1968. Determination of submicrogram quantities of mercury by atomic absorption spectrophotometry. *Analytical Chemistry*, 40(14):2085-2087.
- Hodgman, C. D. (editor). 1954. Handbook of chemistry and physics. 36th edition. Chemical Rubber Publishing Co., Cleveland, Ohio, pp. 218-223.
- Horne, A. J. 1972. Nitrogen: Recent studies on the role of nitrogen in the biostimulation and eutrophication of aquatic ecosystems. In: Proceedings of Seminar on Eutrophication and Biostimulation, R. L. Brown, editor, California Dept. of Water Resources, pp. 52-70.
- Horne, A. J., S. E. Dillar, D. K. Fujita, and C. R. Goldman. 1972. Nitrogen fixation in Clear Lake, California. II. Synoptic studies on the autumn *Anabaena* bloom. *Limnol. Oceanogr.* 17(5):693-703.
- Horne, A. J., and G. E. Fogg. 1970. Nitrogen fixation in some English lakes. *Proc. Roy. Soc. Lond. B.* 175:351-366.
- Horne, A. J., and C. R. Goldman. 1972. Nitrogen fixation in Clear Lake, California. I. Seasonal variation and the role of heterocysts. *Limnol. Oceanogr.*, 17:678-692.
- Horne, A. J., and A. B. Viner. 1971. Nitrogen fixation and its significance in tropical Lake George, Uganda. *Nature* 232:417-418.
- Hurst, R. L. 1972. Statistical program package (STATPAC). Department of Applied Statistics and Computer Science, Utah State University, Logan, Unpublished mimeo.
- Hurst, R. L. 1974. Personal communication. Department of Applied Statistics and Computer Science, Utah State University, Logan.
- Hwang, C. P., P. M. Huang, and T. H. Lackie. 1975. Phosphorus distribution in Blockstrap Lake sediments. *Jour. WPCF* 47:1081-1085.
- Imura, N., E. Sukegawa, S. Pan, K. Nagao, J. Kim, T. Kwan, and T. Ukita. 1971. Chemical methylation of inorganic mercury with methyl-cobalamin. *Science* 172:1248-1249.
- Jensen, S., and A. Jernelöv. 1969. Biological methylation of mercury in aquatic organisms. *Nature* 223:753-754.
- Jernelöv, A. 1969. Conversion of mercury compounds. In: M. W. Miller and G. G. Berg, editors. Chemical fallout. C. C. Thomas, Springfield, Illinois. 198 p.
- Jernelöv, A. 1970. Release of methylmercury from sediments with layers containing inorganic mercury at different depths. *Limnol. Oceanogr.* 15:958-960.
- Joensuu, O. 1971. Fossil fuels as a source of mercury pollution. *Science* 172:1027-1028.
- Keeney, D. R. 1972. The fate of nitrogen in aquatic ecosystems. University of Wisconsin Water Resource Center, Madison.
- Keeney, D. R. 1973. The nitrogen cycle in sediment-water systems. *Jour. Environ. Quality* 2:15-28.
- Keeney, D. R. 1974. Protocol for evaluating the nitrogen status of lake sediments. EPA-660/3-73-024. Superintendent of Documents. 25 p.
- Keeney, D. R., J. G. Konrad, and G. Chesters. 1970. Nitrogen distribution in some Wisconsin lake sediments. *Jour. WPCF* 42:411-417.
- Kerr, P. C., D. L. Brockway, D. F. Paris, and S. E. Craven. 1973. Carbon cycle in sediment-water systems. *Jour. Environ. Quality* 2:46-51.

- Kolb, L. P., D. B. Porcella, and E. J. Middlebrooks. 1973. Ecological implications of dimethyl mercury in an aquatic food chain. Utah Water Research Laboratory, PRWG105-2, Utah State University, Logan.
- Konrad, J. G., D. R. Keeney, G. Chesters, and K. Chen. 1970. Nitrogen and carbon distribution in sediment cores of selected Wisconsin lakes. *Jour. WPCF* 42:2094-2101.
- Kuznetsov, S. I. 1959. Die rolle der mikroorganismen in staffkreislauf der seen. Kerkin. Referenced in Horne, 1972.
- Kuznetsov, S. I. 1968. Recent studies on the role of microorganisms in the cycling of substances in lakes. *Limnol. Oceanogr.* 13:211-224.
- Langley, D. 1973. Mercury methylation in an aquatic environment. *Jour. WPCF* 45(1):44-51.
- Lee, G. F. 1970. Factors affecting the transfer of material between water and sediments. Eutrophication Information Program, University of Wisconsin, Madison. Literature Review No. 1.
- Loomis, A. G. 1928. Solubilities of gases in water. In: E. W. Washburn (editor). *International critical table*. 3:255-261, McGraw-Hill Co., Inc., New York.
- Lorenzen, M. W. 1973. Predicting the effects of nutrient diversion on lake recovery. In: *Modeling the eutrophication process*, E. J. Middlebrooks et al., editors, Utah Water Research Laboratory, PRWG136-1, Utah State University, Logan, pp. 205-210.
- Luce, W. A. 1974. Phosphorus budget of the Hyrum Reservoir—Little Bear River system. M.S. Thesis, Utah State University, Logan.
- Mortimer, C. H. 1941. The exchange of dissolved substances between mud and water in lakes. *Jour. Ecol.* 29:280-329.
- Mortimer, C. H. 1942. The exchange of dissolved substances between mud and water in lakes. *Jour. Ecol.* 30:147-201.
- Murray, R. B. 1972. Nutrients and phytoplankton in Hyrum Lake. M.S. Thesis, Utah State University, Logan.
- Newsome, W. 1971. Determination of methylmercury in fish and in cereal grain products. *Jour. Agr. Food Chem.* 19(3):567-569.
- Ostle, B. 1963. *Statistics in research*. 2nd Edition, The Iowa State University Press, Ames, Iowa. 585 p.
- Patrick, R. 1973. Environmental and health effects of nitrogenous compounds—aquatic systems. In: *Nitrogenous Compounds in the Environment*. EPA-SAB-73-001, Superintendent of Documents, pp. 127-139.
- Peterson, H. 1973. Personal communication.
- Porcella, D. B., P. A. Cowan, and E. J. Middlebrooks. 1973. Biological response to detergent and nondetergent phosphorus in sewage. *Water and Sewage Works*, Nov.-Dec. 10 p.
- Porcella, D. B., J. S. Kumagui, and E. J. Middlebrooks. 1970. Biological effects on sediment-water nutrient interchange. *Jour. San. Eng. Div., ASCE* 96:911-926.
- Porcella, D. B., K. L. Schmalz, and W. A. Luce. 1972. Sediment-water nutrient interchange in eutrophic lakes. *Proceedings of Seminar on Eutrophication and Bio-stimulation*, California Department of Water Resources, pp. 83-110.
- Rudd, J. W. M., R. D. Hamilton, and N. E. R. Campbell. 1974. Measurement of microbial oxidation of methane in lake water. *Limnol. Oceanogr.* 19:519-524.
- Sawyer, C. N. 1947. Fertilization of lakes by agricultural and urban drainage. *Jour. New England Water Works Assoc.* 61:109.
- Sawyer, C. N., J. B. Lackey, and R. T. Lenz. 1945. An investigation of the odor nuisances occurring in Madison Lakes, particularly Monona, Waubesa and Kegonsa from July, 1942-July 1944. Report of Governor's Committee, Madison, Wisconsin, 2 vols., mimeo. 171 p.
- Schindler, D. W., and E. J. Fee. 1974. Experimental lakes area: Whole-lake experiments in eutrophication. *Jour. Fish. Res. Bd. Canada* 31:937-953.
- Schmalz, K. L. 1971. Phosphorus distribution in the bottom sediments in Hyrum Reservoir. M.S. Thesis, Utah State University, Logan.
- Shacklette, H. 1971. Mercury in the environment - surficial materials of the conterminous United States. U.S. Geol. Survey Prof. Paper 644, 5 p.
- Smith, K. A., and S. W. F. Restall. 1971. The occurrence of ethylene in anaerobic soils. *Jour. Soil Sci.*, 22:430-443.
- Spangler, W., J. Spigarelli, M. Rose, R. Flippin, and H. Miller. 1973. Degradation of methylmercury by bacteria. *Applied Microbiology* 25(4):488-493.
- Stewart, W. D. P., G. P. Fitzgerald, and R. H. Burris. 1967. *In situ* studies on N₂ fixation using the acetylene reduction technique. *Proc. Nat. Acad. Sci.* 58(5):2071-2078.
- Stratton, F. E., and P. L. McCarty. 1968. Discussion on evaluation of nitrification in streams. *J. San. Eng. Div., ASCE* 95:952.
- Strickland, J. D. H., and T. R. Parsons. 1968. *A practical handbook of seawater analysis*. Fisheries Research Board of Canada, Ottawa. 311 p.
- Stumm, W., and G. F. Lee. 1961. Oxygenation of ferrous iron. *Ind. Eng. Chem.* 53:143.
- Stumm, W., and J. J. Morgan. 1970. *Aquatic chemistry*. Wiley-Interscience. 583 p.
- Syers, J. K., R. F. Harris, and D. E. Armstrong. 1973. Phosphate chemistry in lake sediments. *Jour. Environ. Quality*, 2:1-14.
- Theis, T. L., and P. C. Singer. 1973. The stabilization of ferrous iron by organic compounds in natural waters. In: *Trace metals and metal-organic interactions in natural waters*. P. C. Singer, editor, Ann Arbor Science Publishers, Ann Arbor, Michigan.
- Theis, T. L., and P. C. Singer. 1974. Complexation of Fe(II) by organic matter and its effect in Fe(II) oxygenation. *Env. Sci. Tech.* 8:569-573.

- Thomann, R. V., D. S. O'Connor, and D. M. DiToro. 1970. Modeling of the nitrogen and algal cycles in estuaries. Presented at the Fifth Conference of the International Association on Water Pollution Research, San Francisco, California.
- USPHS. 1962. Public Health Service drinking water standards. USDHEW, PHS No. 956. 61 p.
- Wallace, R., W. Fulkerson, W. D. Shulz, and W. S. Lyon. 1971. Mercury in the environment: The human element. Oak Ridge National Laboratory, Oakridge, Tenn., 50 p.
- Westöo, G. 1966. Determination of methylmercury in foodstuffs. *Acta Chemica Scandinavica* 20:2131-2137.
- Westöo, G. 1967. Determination of methylmercury compounds in foodstuffs. *Acta Chemica Scandinavica* 21:1790-1800.
- Westöo, G. 1968. Determination of methylmercury salts in various kinds of biological material. *Acta Chemica Scandinavica* 22:2277-2280.
- Wildung, R. E., and R. L. Schmidt. 1973. Phosphorus release from lake sediments. EPA-R3-73-024, Superintendent of Documents. 185 p.
- Wood, J., and F. Kennedy. 1968. Synthesis of methylmercury compounds by extracts of a methanogenic bacterium. *Nature* 220:173-174.

APPENDIXES

Appendix A

Analytical Methods

Parameter (PHASE)	Method	Ref.	Parameter (PHASE)	Method	Ref.
A. (AQUEOUS)			7. Soluble Total Carbon	Combustion, Infrared	2
I. Unfiltered			8. Soluble Inorganic Carbon	Combustion, Infrared	2
1. Total Phosphorus	Persulfate Digestion	1	9. Soluble Total Iron Carbon	Bathophenanthroline	3
2. Organic Nitrogen	Digestion, Distillation	1	10. Soluble Total Mercury	A. Flameless AA B. Gas Chromatograph: Mercury Column	4
3. Total Carbon	Combustion, Infrared	2	B. (SEDIMENT)		
4. Inorganic Carbon	Combustion, Infrared	2	1. Total Phosphorus	A. Persulfate Digestion	1
5. Total Iron	Bathophenanthroline	3		B. HClO ₃ Digestion	1
6. Ferrous Iron	Phenanthroline	1	2. Total Available Phosphorus	A. Dilute Fluoride-Dilute HCl Soluble P B. NaHCO ₃ Extraction	1
7. Total Mercury		4	3. Total Nitrogen	Combustion	8
A. Flameless AA			4. Total Organic Carbon	A. Dichromate Oxidation B. Colorimetric	9 13
B. Gas Chromatograph: Mercury Column			5. Inorganic Carbon	Monometric	13
Column Description: 3 ft. of 1/8" O.D. stainless steel GLC column			6. Total Iron	HClO ₄ digest, AA	11
Packing Description: 3% Hi-Eff 4BP on Gas Chrom Q, 80-100 mesh			7. Total Extractable Iron	Diethylenetriamine pentaacetic acid extraction, AA	11,12
Detector: Flame			8. Nitrate Nitrogen	Phenol disulfonic acid colorimetric	
Oven Temperature: 140°C			C. (GAS)		
Injector Temperature: 180°C			1. Nitrogen	Gas Chromatograph molecular sieve 5A	10
Detector Temperature: 280°C			2. Oxygen	Gas Chromatograph molecular sieve 5A	10
Carrier Gas: Helium			3. Methane	Gas Chromatograph molecular sieve 5A	10
Sample Size: 1.0 µl				Column Description: 6 ft. of 1/8" stainless steel	
Methane, dimethyl mercury, and monomethyl mercury all had similar retention times				Packing: Molecular Sieve 5A	
8. Suspended Solids	Glass Fiber Filter (103°C)	1		Carrier gas: Helium	
9. Volatile Suspended Solids	Glass Fiber Filter (550°C)	1		Flow rate = 30 ml/min	
10. pH	Electrometric	6		Detector: Thermal conductivity	
11. Dissolved Oxygen	Winkler; Azide Modification	1		Sample size: 1.0 µl	
12. Chlorophyll	Relative Fluorescence	7			
II. Filtered					
1. Ortho-Phosphate	Antimony-Molybdate, Ascorbic Acid	1			
2. Total Soluble Phosphorus	Persulfate Digestion	1			
3. Nitrite Nitrogen	Diazotization	3			
4. Nitrate Nitrogen	Cadmium Reduction	3			
5. Ammonia Nitrogen	Indophenol	5			
6. Soluble Organic Nitrogen	Digestion, Distillation	1			

Parameter (PHASE)	Method	Ref.
	Attenuation: Variable	
	Column Temperature: 100°C	
	Detector Temperature: 260°C	
	Injector Temperature: 100°C	
4. Carbon Dioxide	Gas Chromatograph Porapak S	10
5. Ethylene	Gas Chromatograph Porapak R	10
	Column Description: 6 ft. of 1/8" stainless steel	
	Packing: Porapak R	
	Carrier gas: Helium	
	Flow rate = 30 ml/min	
	Detector: Flame	
	Sample size: 0.5 cc	
	Attenuation: Variable	
	Column Temperature: 50°C	
	Detector Temperature: 260°C	
	Injector Temperature: 100°C	

References

1. Standard Methods for the Examination of Water and Wastewater, 1971.
2. Beckman Total Organic Carbon Analyzer Instruction Manual Model 915.
3. Strickland and Parsons, A Practical Handbook of Sea-water Analysis, 1968.
4. Coleman Mercury Analyzer System Operational Manual, Model MAS-50.
5. Solórzano, Limn. & Ocean. 14(5), September 1969.
6. Beckman Manual, Zeromatic II.
7. Turner Fluorometer Manual, Model 110.
8. Coleman Total Nitrogen Analyzer Manual Model.
9. Walkley, J. Agr. Sci. 25:598-609, 1935.
10. Supelco, Inc., Bellefonte, PA.
11. Model 88 Jerrel Ash Ins.
12. Lindsay, W. L., Colorado State University.
13. Adapted from University of Colorado, Agronomy Series No. 9, pp. 1392.
14. University of Colorado, Agronomy Series No. 9, pp. 1374.

Column—Molecular Sieve 5A
0.5 cc Injection at
attenuation of 64 for air
and samples 1 → 4 then
attenuation of 32 for
samples 5 → 16

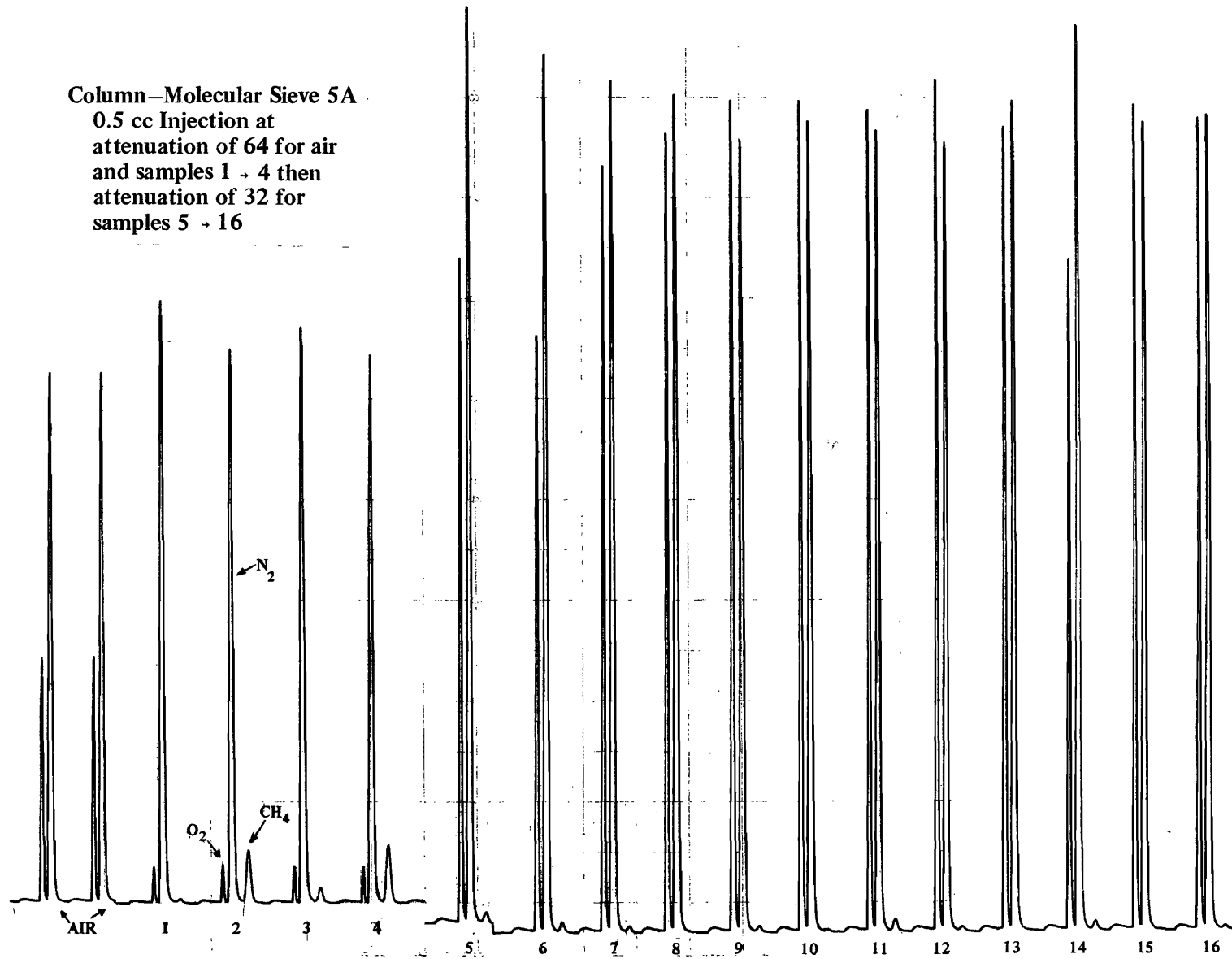

Column—Porapak S
0.5 cc Injection at
attenuation of 128
for first peak then
attenuation of 2 for
remaining peaks

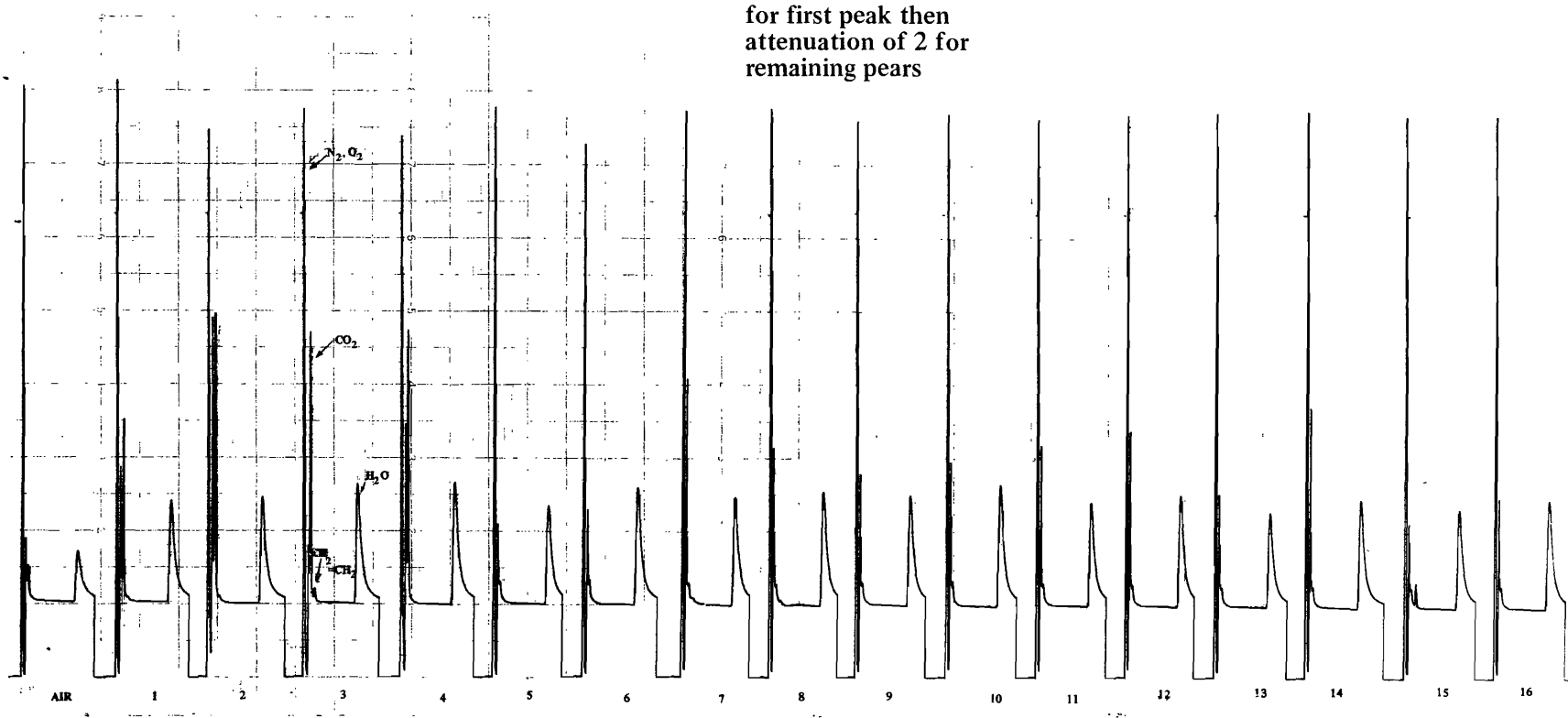

Appendix B

Program Micro

Introduction

A digital computer program was developed to calculate mass balances for the microcosms. The mass balances included the following constituents:

- a. Gaseous nitrogen (N₂)
- b. Gaseous oxygen (O₂)
- c. Gaseous carbon dioxide (CO₂)
- d. Methane (CH₄)
- e. Ethylene (CH₂ = CH₂)
- f. Total phosphorus (P)
- g. Total nitrogen (N)
- h. Total carbon (C)
- i. Total iron (Fe)
- j. Total mercury (Hg)

The mass balance for each of the above constituents in each microcosm can be written simply as:

$$\begin{array}{c}
 \left[\begin{array}{l} \text{Net Change in Mass} \\ \text{in Microcosm J} \\ \text{During a One Day} \\ \text{Period} \end{array} \right] \\
 \text{(Term 1)}
 \end{array}
 =
 \begin{array}{c}
 \left[\begin{array}{l} \text{Total Mass in Micro-} \\ \text{cosm J Before} \\ \text{Servicing on the} \\ \text{Current Day} \end{array} \right] \\
 \text{(Term 2)}
 \end{array}
 -
 \begin{array}{c}
 \left[\begin{array}{l} \text{Total Mass in Microcosm} \\ \text{J After Servicing on the} \\ \text{Previous Day} \end{array} \right] \\
 \text{(Term 3)}
 \end{array}
 \dots \dots \dots (1)$$

After term 1 has been calculated for the current day, then term 2 is adjusted for the mass gained or lost during servicing to become term 3 for the following day. Thus the program steps through time, a day at a time, calculating the net gain or loss of mass for each constituent in each microcosm.

Constituent concentrations in the microcosms were measured at approximately two week intervals. Intermediate daily values for the mass balances were obtained by linear interpolation between the measured values at the beginning and end of the interval.

Solution Technique

Figure B-1 is a descriptive flow diagram of the main program. The steps in Figure B-1 are keyed to comment cards in the program listing to assist in tracing program logic.

Output data are written on disk files (11 through 26); one file for each microcosm. These data are transferred from disk to the line printer by standard list and plot programs.

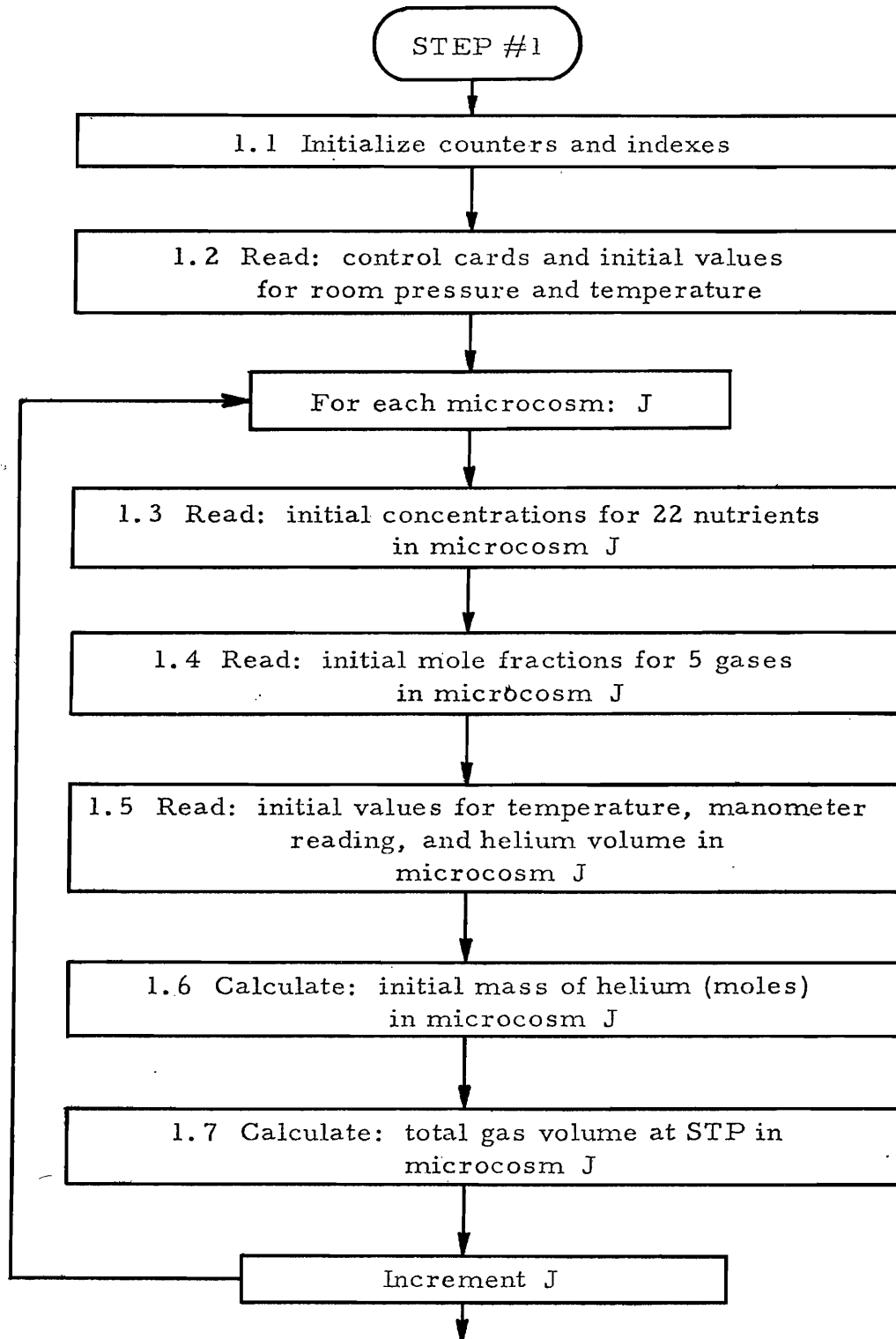

Figure B-1. Flow diagram for program MICRO.

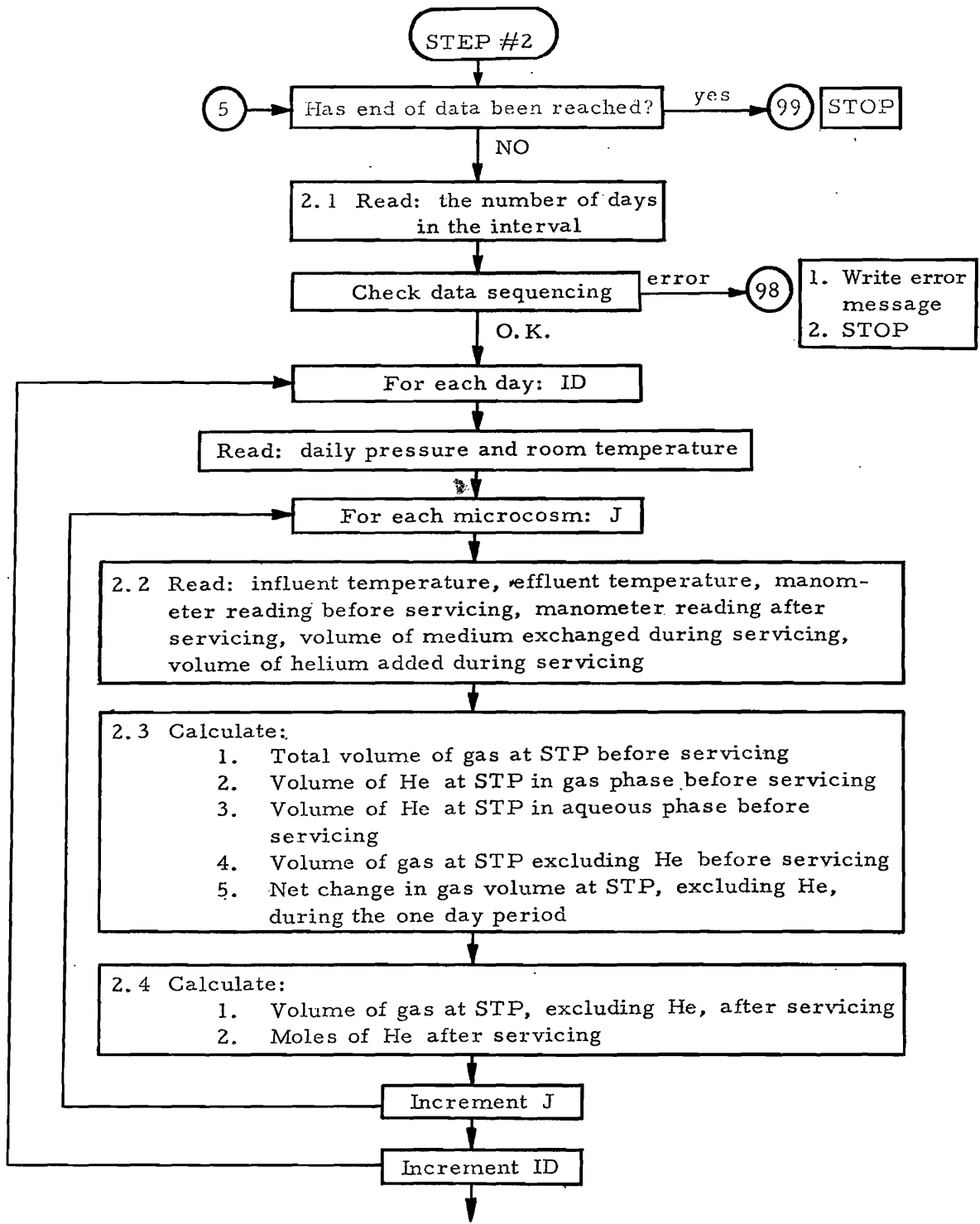

Figure B-1. Continued.

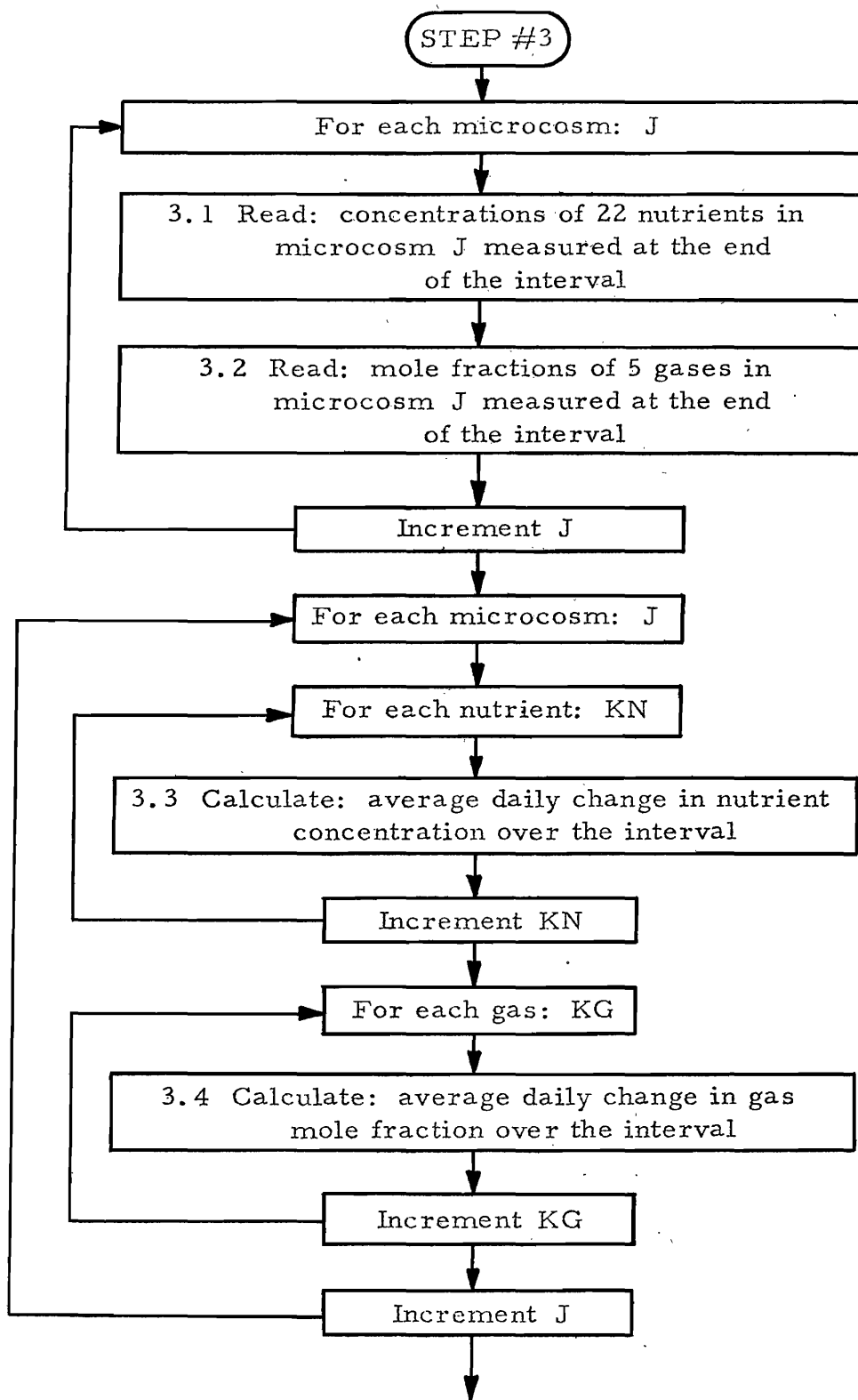

Figure B-1. Continued.

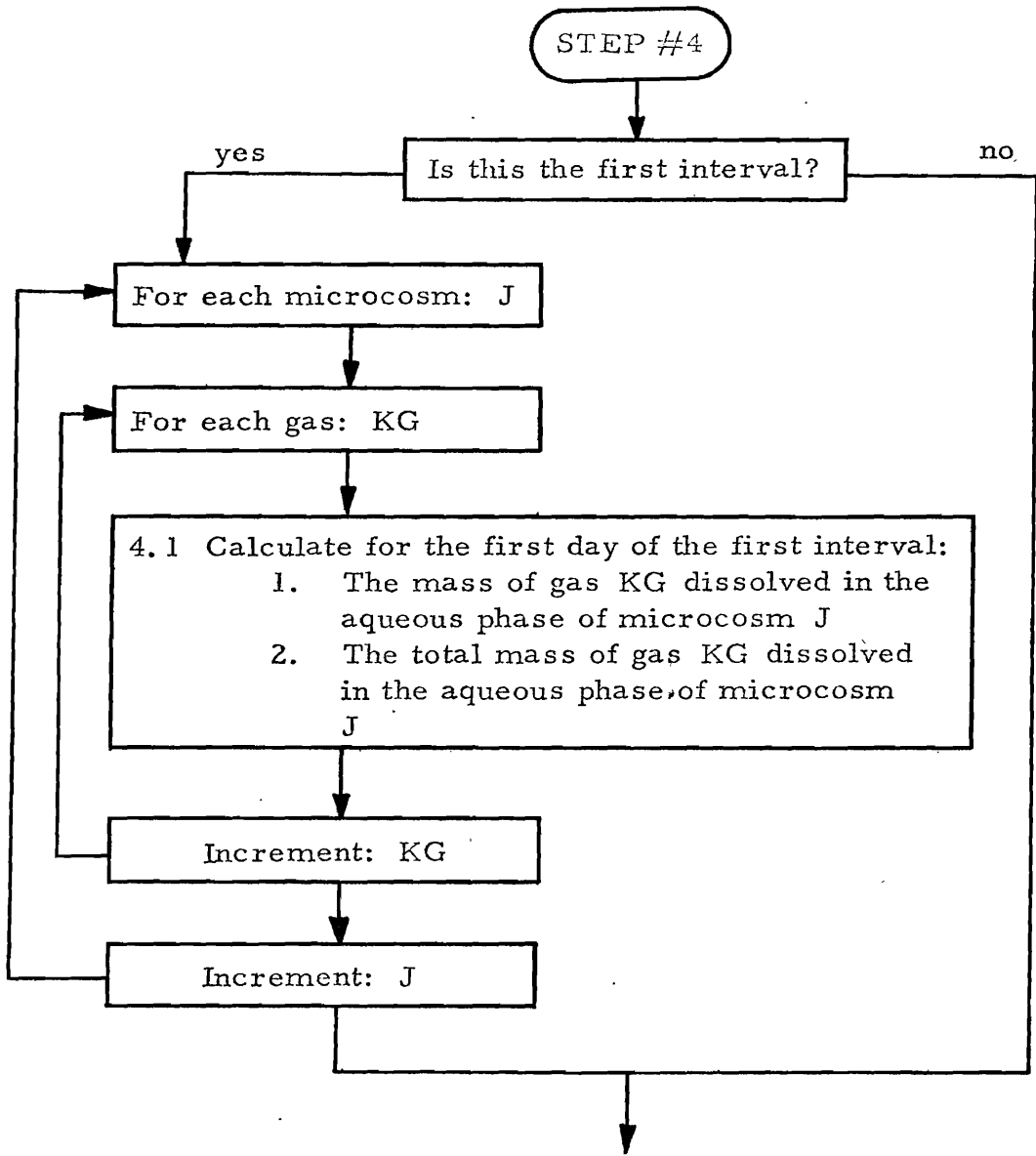

Figure B-1. Continued.

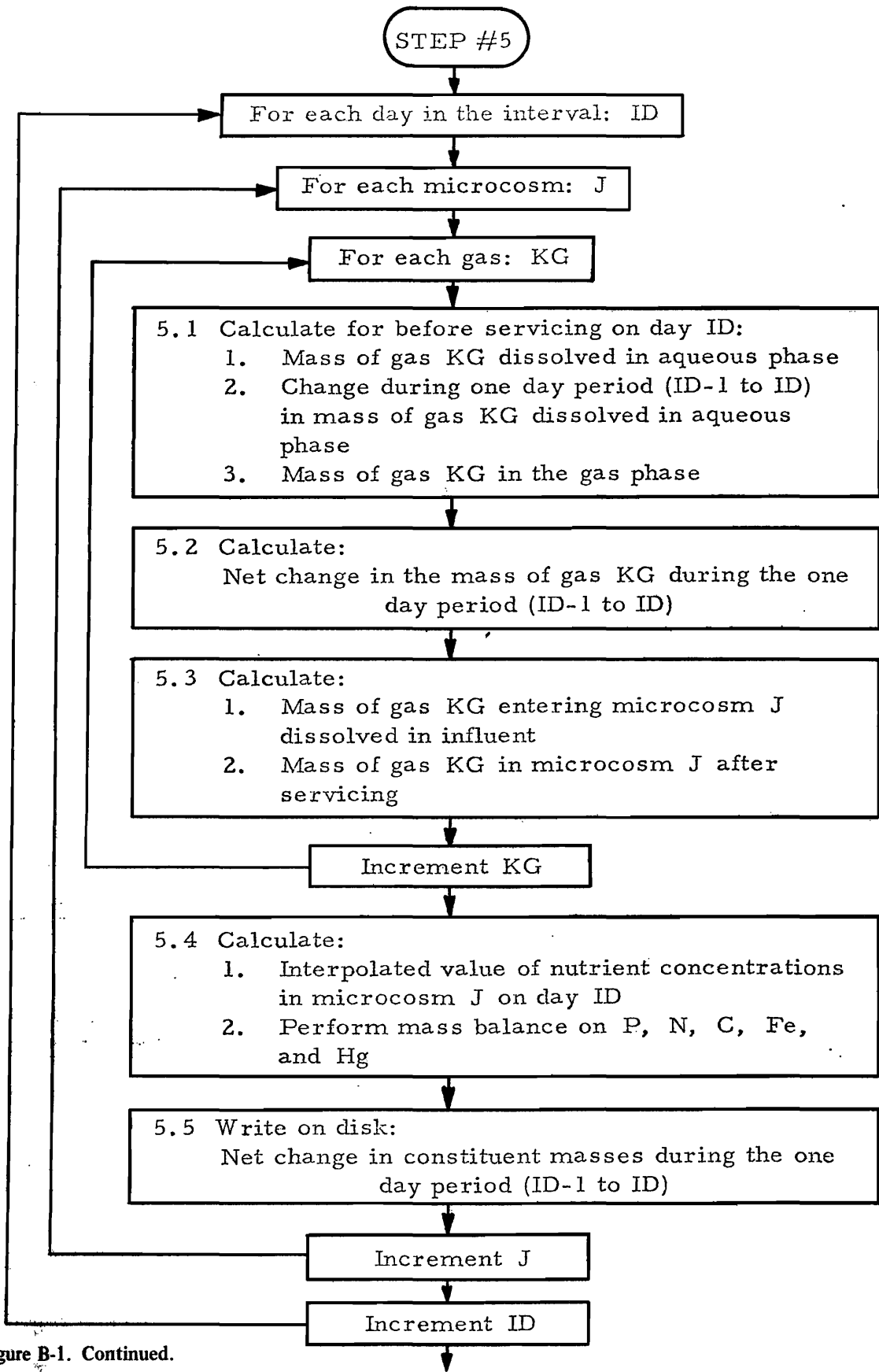

Figure B-1. Continued.

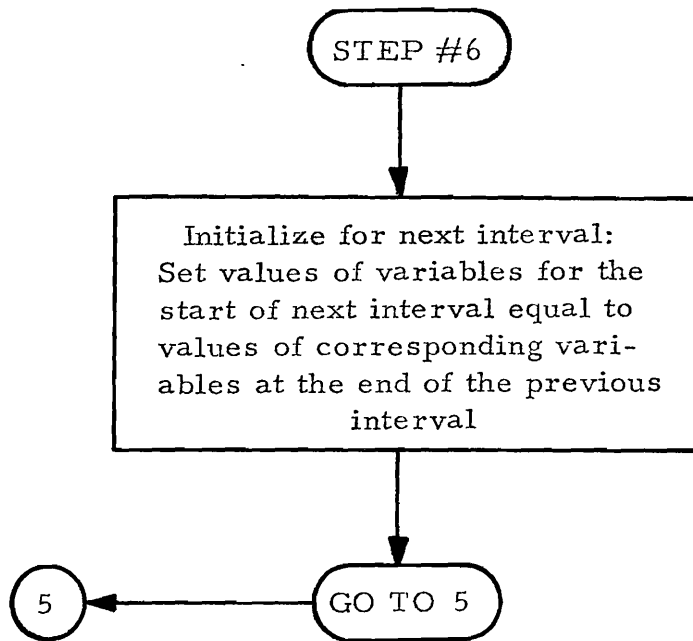

Figure B-1. Continued.

PROGRAM MICRO

DESCRIPTION OF INPUT VARIABLES

IOPT	{ IOPT = 2 Write input data and output on line printer IOPT = 1 Write input data only on line printer IOPT = 0 No output on line printer
NMICRO	Number of microcosms
NNUTI	Number of nutrients in the influent
NNUTO	Number of nutrients in the effluent
NGASI	Number of gases measured in the influent
NGASO	Number of gases measured in microcosm gas phase
MINO(L)	Identification numbers of microcosms ($L \leq 20$)
P(ID)	Atmospheric pressure on day ID (mm Hg) ($ID \leq 30$)
RT(ID)	Room temperature on day ID ($^{\circ}\text{C}$) ($ID \leq 30$)
XNO(KN,J,IST)	Concentration of nutrient KN measured in the effluent from microcosm J at the start of the interval (mg/l) ($J \leq 20$)
	KN = 1 Unfiltered total phosphorus (mg P/l)
	KN = 2 Unfiltered total nitrogen, excluding N_2 (mg N/l)

KN = 3 Unfiltered total carbon (mg C/l)
 KN = 4 Unfiltered total iron (mg Fe/l)
 KN = 5 Unfiltered total mercury (mg Hg/l)
 KN = 6 Suspended solids (mg/l)
 KN = 7 Volatile suspended solids (mg/l)
 KN = 8 Unfiltered ferrous iron (mg Fe⁺⁺/l)
 KN = 9 Unfiltered inorganic carbon (mg C/l)
 KN = 10 Unfiltered organic carbon (mg C/l)
 KN = 11 Filtered orthophosphate (mg P/l)
 KN = 12 Filtered total phosphorus (mg P/l)
 KN = 13 Filtered nitrate + nitrite (mg N/l)
 KN = 14 Filtered nitrite (mg N/l)
 KN = 15 Filtered nitrate (mg N/l)
 KN = 16 Filtered ammonia (mg N/l)
 KN = 17 Filtered total nitrogen (mg N/l)
 KN = 18 Filtered total carbon (mg C/l)
 KN = 19 Filtered inorganic carbon (mg C/l)
 KN = 20 Filtered organic carbon (mg C/l)
 KN = 21 Filtered total iron (mg Fe/l)
 KN = 22 Filtered total mercury (mg Hg/l)

XNO(KN,J,IED) Concentration of nutrient KN measured in the effluent from microcosm J at the end of the interval (mg/l)

XGO(KG,J,IST) Mole fraction of gas KG in gas phase of microcosm J at the start of the interval (mole fraction, excluding He)

KG = 1 Nitrogen (mole fraction N₂)
 KG = 2 Oxygen (mole fraction O₂)
 KG = 3 Carbon dioxide (mole fraction CO₂)
 KG = 4 Methane (mole fraction CH₄)
 KG = 5 Ethylene (mole fraction CH₂=CH₂)

XGO(KG,J,IED) Mole fraction of gas KG in gas phase of microcosm J at the end of the interval (mole fraction, excluding He)

TI(ID,J) Temperature of influent to microcosm J on the IDth day (°C)

VINI(1,J)	Initial volume of gas phase in microcosm J (ml, excluding He)
NDAYS	Number of days in interval
TO(ID,J)	Temperature of the effluent of microcosm J on day ID (°C)
CR	Current reading on the manometer immediately before servicing (ml)
VADJ	Reading on the manometer immediately after servicing (omit if same as CR) (ml)
F(ID,J)	Volume of medium exchanged during servicing (omit if = 0.9) (l)
HE	Volume of He added during servicing (ml)

PROGRAM MICRO

DESCRIPTION OF INTERNAL VARIABLES

VINI(ID,J)	Total volume of gas, excluding He, at STP in the gas phase immediately after servicing on day ID (ml STP)
YADD	Moles of helium added to microcosm (moles He)
Y(J)	Total moles of helium in microcosm (moles He)
YG	Moles of helium in the gas phase (moles He)
YA	Moles of helium in the aqueous phase (moles He)
VP	Vapor pressure of water at specified temperature (mm Hg)
VOGSTP(ID,J)	Total volume of gas, excluding He, at STP in the gas phase immediately before servicing on day ID (ml STP)
V	Total volume of gas in gas phase, including He, at STP immediately before servicing (ml STP)
HEGAS(ID,J)	Volume of He at STP in gas phase of microcosm J on day ID immediately before servicing (ml STP)
HEAQU(ID,J)	Volume of He at STP in aqueous phase of microcosm J on day ID immediately before servicing (ml STP)
VNET(ID,J)	Net change in gas volume, excluding He, at STP during the one day period (ID-1) to (ID) (ml STP)
CXNO(KN,J)	Incremental daily change in nutrient KN in microcosm J derived from linear interpolation over the interval of NDAYS (mg/l)
DXCO(KG,J)	Incremental daily change in gas KG in microcosm J derived from linear interpolation over the interval of NDAYS (mole/fraction)
INT	Counter for time interval
ID	Counter for day within interval
IDS	Counter for consecutive day from start of run

RK	Coefficient for Henry's law
XMGASO(KG,J)	Total mass of gas KG in microcosm J immediately following servicing (mg)
XMGPRE(KG,J)	Total mass of gas KG in the aqueous phase of microcosm J immediately following servicing on the preceding day (mg)
Z(KG)	Molecular weight of gas KG (mg/mole)
J	Index equal to microcosm identification number
XGO(KG,J,IST)	Interpolated value of mole fraction of gas KG in gas phase of microcosm J on day ID (mole fraction, excluding He)
XNO(KN,J,IST)	Interpolated value of concentration of nutrient KN in aqueous phase of microcosm J on day ID (mg/l)
XMGASA(KG)	Mass of gas KG in the aqueous phase (mg)
XMGASG(KG)	Mass of gas KG in the gas phase (mg)
GASNET(KG)	Net change in mass of gas KG during the one day period (ID-1) to (ID) (mg)
XMGASI(KG)	Mass of gas KG input to the system in the influent water (mg)
XP	Net change in the mass of total phosphorus during the one day period (ID-1) to (ID) (mg P)
FE	Net change in the mass of total iron during the one day period (ID-1) to (ID) (mg Fe)
HG	Net change in the mass of total mercury during the one day period (ID-1) to (ID) (mg Hg)
XN	Net change in the mass of total nitrogen, including N ₂ , during the one day period (ID-1) to (ID) (mg N)
C	Net change in the mass of total carbon during the one day period (ID-1) to (ID) (mg C)
O ₂	Net change in the mass of oxygen during the one day period (ID-1) to (ID) (mg O ₂)
FA(KG)	Mole fraction of gas KG in the atmosphere (mole fraction)
VOLG(J)	Volume of gas phase in microcosm J when manometer is zeroed (ml)
XINI(KN)	Concentration of nutrients, common to all microcosms, in the influents (mg/l)
XIN2(KN,J)	Concentration of nutrients, which vary among microcosms, in the influents (mg/l)

PROGRAM MICRO

DESCRIPTION OF OUTPUT VARIABLES

XP	Same description as in "Internal Variables"
FE	Same description as in "Internal Variables"
HG	Same description as in "Internal Variables"
XN	Same description as in "Internal Variables"

C Same description as in "Internal Variables"

O₂ Same description as in "Internal Variables"

VNET(ID,J) Net change in gas volume, excluding He, at STP during the one day period (ID-1) to (ID) (ml STP)

GASNET(KG) Net change in mass of gas KG during the one day period (ID-1) to (ID)

KG = 1 Nitrogen (mg N₂)

KG = 2 Oxygen (mg O₂)

KG = 3 Carbon dioxide (mg CO₂)

KG = 4 Methane (mg CH₄)

KG = 5 Ethylene (mg CH₂ CH₂)

PROGRAM MICRO

VALUES OF THE CONSTANTS

Description	Symbol	Nitrogen	Oxygen	Carbon Dioxide	Methane	Ethylene
Molecular Weight	Z(KG)	28010	32000	42010	16040	28050
Mole Fraction in the Atmosphere	FA(KG)	0.7808	0.2095	0.00033	0.0	0.0

Microcosm Identification Number	Microcosm Gas Volume VOL(J) (ml)	Concentration of Nutrient in the Influent				
		Total Phosphorus XIN1(1) (mg/l)	Total Nitrogen XIN2 (2,J) (mg/l)	Total Carbon XIN1(3) (mg/l)	Total Iron XIN1(4) (mg/l)	Total Mercury XIN2(5,J) (mg/l)
1	419.	0.095	0.312	4.8	0.017	0.0
2	343.	0.095	0.607	4.8	0.017	0.0
3	514.	0.095	0.298	4.8	0.017	0.05
4	319.	0.095	0.595	4.8	0.017	0.05
5	524.	0.095	0.595	4.8	0.017	0.0
6	336.	0.095	0.595	4.8	0.017	0.0
7	485.	0.095	0.595	4.8	0.017	0.05
8	359.	0.095	0.595	4.8	0.017	0.05
9	359.	0.095	0.595	4.8	0.017	0.0
10	382.	0.095	0.595	4.8	0.017	0.0
11	360.	0.095	0.595	4.8	0.017	0.05
12	357.	0.095	0.595	4.8	0.017	0.05
13	359.	0.095	0.595	4.8	0.017	0.0
14	505.	0.095	0.595	4.8	0.017	0.0
15	482.	0.095	0.595	4.8	0.017	0.05
16	506.	0.095	0.595	4.8	0.017	0.05

Appendix C

Analytical Results

Table C-1. Gas mole fractions.

(SAMPLE)

Microcosm 1					
Day	N ₂	O ₂	CO ₂	CH ₄	C ₂ H ₄
7	.781	.209	.0003		
13	.846	.146	.004	.004	
27	.936	.052	.004	.004	
42	.876	.026	.013	.09	
56	.917	.054	.006	.018	
70	.906	.059	.003	.026	
84	.905	.063	.003	.023	
98	.915	.028	.005	.039	.0001
111	.923	.024	.006	.036	.0003
126	.941	.024	.005	.019	.0003
140	.95	.026	.005	.008	.0002
154	.956	.028	.005	.0001	
168	.951	.027	.007	.004	.0002
187	.953	.027	.005	.006	.0002
Microcosm 2					
7	.781	.209	.0003		
13	.846	.146	.004	.004	
27	.927	.052	.007	.01	
42	.876	.026	.013	.09	
56	.861	.05	.006	.078	
70	.832	.077	.005	.083	
84	.842	.073	.005	.074	
98	.833	.034	.008	.114	.0001
111	.645	.021	.008	.115	.0001
126	.852	.025	.009	.102	.0002
140	.86	.027	.007	.095	.0002
154	.888	.029	.006	.063	.0002
168	.878	.029	.008	.074	.0002
187	.888	.029	.007	.067	.0003

Table C-1. Continued.

Microcosm 3					
Day	N ₂	O ₂	CO ₂	CH ₄	C ₂ H ₄
7	.781	.209	.0003		
13	.846	.146	.004	.004	
27	.936	.047	.006	.006	
42	.91	.021	.009	.061	
56	.878	.06	.005	.052	
70	.877	.04	.006	.072	
84	.874	.066	.005	.048	.0001
98	.891	.029	.008	.059	.0005
111	.913	.026	.003	.041	.0005
126	.921	.024	.008	.035	.0007
140	.923	.027	.007	.029	.0005
154	.935	.028	.007	.019	.0003
168	.921	.030	.007	.03	.0005
187	.924	.028	.007	.03	.0004

Microcosm 5					
Day	N ₂	O ₂	CO ₂	CH ₄	C ₂ H ₄
7	.781	.209	.0003		
13	.771	.225	.0001	.004	
27	.686	.303	.0001	.006	
42	.658	.325	.0001	.012	
56	.63	.346	.0001	.019	
70	.715	.268	.001	.012	
84	.716	.272	.0008	.006	
98	.652	.329	.0005	.006	
111	.664	.323	.0006	.003	.0001
126	.65	.336	.0005	.003	
140	.663	.318	.0006	.007	
154	.649	.337	.0006	.002	
168	.734	.249	.0009	.005	
187	.696	.29	.0005	.003	

Microcosm 4					
Day	N ₂	O ₂	CO ₂	CH ₄	C ₂ H ₄
7	.781	.209	.0003		
13	.846	.146	.004	.004	
27	.936	.047	.006	.006	
42	.91	.021	.009	.061	
56	.912	.064	.004	.014	
70	.866	.083	.005	.045	
84	.856	.059	.004	.065	
98	.852	.045	.006	.085	.0001
111	.847	.024	.008	.109	.0002
126	.851	.024	.008	.106	.0002
140	.85	.026	.007	.103	.0002
154	.836	.051	.036	.064	.0001
168	.872	.042	.013	.059	.0001
187	.9	.037	.007	.047	.0001

Microcosm 6					
Day	N ₂	O ₂	CO ₂	CH ₄	C ₂ H ₄
7	.781	.209	.0003		
13	.758	.238	.0001	.004	
27	.792	.19	.0001	.006	
42	.74	.245	.0001	.01	
56	.687	.30	.0001	.008	
70	.694	.289	.001	.012	
84	.736	.249	.0008	.008	
98	.829	.153	.0009	.004	.0001
111	.86	.112	.002	.014	
126	.675	.24	.0006	.071	
140	.672	.304	.0008	.009	
154	.735	.246	.0008	.003	
168	.87	.109	.002	.008	
187	.77	.21	.0006	.01	

Table C-1. Continued.

Microcosm 7					
Day	N ₂	O ₂	CO ₂	CH ₄	C ₂ H ₄
7	.781	.209	.0003		
13	.784	.213	.0001	.003	
27	.653	.335	.0001	.007	
42	.676	.31	.0001	.009	
56	.698	.286	.0001	.011	
70	.683	.298	.001	.014	
84	.635	.348	.0008	.010	
98	.56	.412	.0005	.013	
111	.564	.416	.0006	.008	
126	.6	.385	.0006	.003	
140	.614	.367	.0006	.006	
154	.594	.391	.0006	.003	
168	.653	.331	.0008	.003	
187	.62	.363	.0005	.006	

Microcosm 9					
Day	N ₂	O ₂	CO ₂	CH ₄	C ₂ H ₄
7	.781	.209	.0003		
13	.738	.255	.0001	.007	
27	.524	.451	.0001	.02	
42	.561	.392	.0001	.039	
56	.53	.41	.0001	.055	
70	.599	.364	.001	.032	
84	.623	.364	.0008	.006	
98	.547	.422	.0006	.016	
111	.566	.414	.0005	.009	
126	.665	.317	.0006	.005	
140	.577	.403	.0006	.006	
154	.548	.43	.0006	.009	.0002
168	.552	.43	.0006	.006	.0002
187	.556	.43	.0006	.003	.0005

Microcosm 8					
Day	N ₂	O ₂	CO ₂	CH ₄	C ₂ H ₄
7	.781	.209	.0003		
13	.696	.301	.0001	.008	
27	.641	.35	.0001	.004	
42	.597	.396	.0001	.002	
56	.553	.442	.0001	.0001	
70	.619	.371	.001	.005	
84	.599	.391	.0008	.003	.0008
98	.599	.387	.0009	.0001	.0001
111	.615	.373	.0006	.0001	.0001
126	.618	.371	.0005	.0001	.0002
140	.603	.383	.0006	.0001	.0002
154	.604	.383	.0007	.0001	.0002
168	.645	.342	.0006	.0001	.0002
187	.612	.378	.0005	.0001	.0003

Microcosm 10					
Day	N ₂	O ₂	CO ₂	CH ₄	C ₂ H ₄
7	.781	.209	.0003		
13	.752	.245	.0001	.003	
27	.505	.468	.0001	.022	
42	.569	.404	.0001	.018	
56	.572	.417	.0001	.006	
70	.64	.351	.001	.004	
84	.602	.382	.0008	.009	
98	.566	.41	.0006	.010	
111	.564	.421	.0006	.003	
126	.583	.399	.0006	.005	
140	.583	.399	.0006	.003	
154	.577	.407	.0007	.003	
168	.586	.401	.0006	.002	
187	.605	.38	.0006	.005	.0001

Table C-1. Continued.

Microcosm 11					
Day	N ₂	O ₂	CO ₂	CH ₄	C ₂ H ₄
7	.781	.209	.0003		
13	.726	.27	.0001	.004	
27	.51	.46	.0001	.025	
42	.554	.405	.0001	.018	
56	.564	.41	.0001	.021	
70	.649	.335	.001	.011	
84	.641	.349	.0008	.003	
98	.609	.372	.0006	.004	
111	.588	.387	.0006	.013	
126	.586	.396	.0006	.004	
140	.58	.397	.0006	.01	
154	.556	.415	.0006	.003	
168	.579	.402	.0006	.007	
187	.584	.403	.0006	.002	

Microcosm 13					
Day	N ₂	O ₂	CO ₂	CH ₄	C ₂ H ₄
7	.781	.209	.0003		
13	.715	.282		.003	
27	.705	.276	.0001	.014	
42	.569	.393	.0001	.030	
56	.595	.393	.0001	.007	
70	.628	.363	.001	.004	
84	.609	.381	.0008	.004	
98	.568	.419	.0004	.0001	
111	.633	.355	.0006	.0001	
126	.612	.376	.0006	.0001	
140	.601	.387	.0006	.0001	
154	.599	.39	.0006	.0001	
168	.608	.379	.0006	.002	
187	.597	.391	.0005	.002	.0001

Microcosm 12					
Day	N ₂	O ₂	CO ₂	CH ₄	C ₂ H ₄
7	.781	.209	.0003		
13	.7	.295	.0001	.005	
27	.51	.471	.0001	.047	
42	.564	.407	.0001	.021	
56	.545	.438	.0001	.012	
70	.635	.356	.001	.004	
84	.607	.382	.0008	.005	
98	.559	.417	.0005	.01	
111	.561	.421	.0006	.006	
126	.561	.423	.0006	.003	
140	.571	.411	.0006	.004	
154	.558	.429	.0006	.0001	
168	.57	.411	.0006	.008	
187	.593	.393	.0006	.004	

Microcosm 14					
Day	N ₂	O ₂	CO ₂	CH ₄	C ₂ H ₄
7	.781	.209	.0003		
13	.729	.269	.0001	.002	
27	.631	.362	.0001	.002	
42	.582	.408	.0001	.002	
56	.577	.412	.0001	.006	
70	.622	.349	.001	.024	
84	.661	.329	.0008	.004	
98	.629	.352	.0006	.005	
111	.694	.292	.0006	.0001	
126	.648	.337	.0006	.004	
140	.655	.323	.0006	.009	
154	.632	.351	.0006	.003	
168	.66	.323	.0007	.005	
187	.635	.343	.0005	.012	

Table C-1. Continued.

Microcosm 15					
Day	N ₂	O ₂	CO ₂	CH ₄	C ₂ H ₄
7	.781	.209	.0003		
13	.773	.218	.0001	.002	
27	.686	.307	.0001	.002	
42	.570	.411	.0001	.002	
56	.571	.421	.0001	.003	
70	.628	.365	.001	.002	
84	.632	.361	.0008	.0001	.0008
98	.594	.392	.0004	.0001	.0004
111	.627	.36	.0005	.0001	.0009
126	.584	.404	.0005	.0001	.001
140	.587	.399	.0006	.0001	
154	.583	.406	.0006	.0001	.0005
168	.594	.393	.0006	.0001	.0005
187	.588	.402	.0005	.0001	.0004

Microcosm 16					
7	.781	.209	.0003		
13	.752	.246	.0001	.002	
27	.676	.316	.0001	.003	
42	.658	.333	.0001	.004	
56	.64	.35	.0001	.005	
70	.666	.321	.001	.008	
84	.649	.341	.0008	.004	
98	.596	.41	.0008	.004	
111	.614	.363	.0006	.01	
126	.586	.4	.0006	.003	
140	.59	.399	.0006	.0001	.001
154	.584	.400	.0006	.001	
168	.593	.389	.0006	.007	
187	.586	.4	.0005	.003	.0001

Table C-2. Nutrients.

Unfiltered

Microcosm 1								Microcosm 3							
Day	TP	TN	TC	TFe	SS	VSS	IC	Day	TP	TN	TC	TFe	SS	VSS	IC
7	.095	.312	4.8	.017	.05	.05	2.6	7	.095	.298	4.8	.017	.05	.05	2.6
13	.087	.614	27.5	.075	11.9	1.4	23	13	.063	1.180	27.5	.036	4.00	.010	24.0
27	.247	1.026	15.	.059	1.0	1.0	11.	27	.283	.211	16.5	.171	1.20	.20	14.0
42	.336	.47	15.5	.290	2.6	1.4	12.	42	.323	.610	19.0	.183	4.5	1.4	14.0
56	.335	.35	14.5	.172	3.6	1.8	10.5	56	.517	.941	16.0	.109	3.1	2.4	13.0
70	.275	.657	14.5	.073	1.2	1.2	10.5	70	.228	.531	15	.075	2.2	1.3	11.5
84	.233	1.038	13.5	.109	1.4	1.3	10	84	.201	.638	14.5	.073	1.2	1.1	10.5
98	.221	.445	13	.102	2.4	1.1	8.5	98	.206	.383	12.5	.118	1.4	.9	9
111	.189	.381	9	.086	1.5	1.4	7	111	.193	.430	9.5	.087	1.4	1.3	7.5
126	.21	.478	11	.1	.5	.5	8	126	.17	.574	14	.11	.01	.01	9.5
140	.152	.765	8	.098	1.5	1.1	7	140	.203	.577	9	.017	1.6	0.7	8
154	.148	.603	12	.035	1.0	0.9	5.5	154	.10	.591	8	.053	.8	.8	5.5
168	.214	.536	8.5	.151	1.7	1.4	7	168	.176	.507	12	.082	1.2	.01	8.5
189	.126	.461	7	.089	.01	.01	7	189	.156	.408	7	.057	1.2	1.1	7

Microcosm 2								Microcosm 4							
Day	TP	TN	TC	TFe	SS	VSS	IC	Day	TP	TN	TC	TFe	SS	VSS	IC
7	.095	.607	4.8	.017	.05	.05	2.6	7	.095	.595	4.8	.017	.05	.05	2.6
13	.083	.904	30.0	.071	11.3	0.7	25.5	13	.074	1.106	27.5	.046	6.10	.01	24.0
27	.415	.439	16.5	.350	0.62	.60	13.0	27	.203	.460	17.	.026	1.7	1.1	14.5
42	.277	.915	19.0	.105	3.3	2.7	13.5	42	.292	.647	16.5	.187	2.2	1.3	12.5
56	.333	.5	17.0	.177	6.1	3.2	13.0	56	.431	.54	15.5	.301	3.6	1.9	12.5
70	.209	.466	15	.045	1.7	0.9	11.5	70	.266	.587	15	.092	2.6	2.0	11.5
84	.208	.726	16	.101	.01	.01	12	84	.252	.690	15.5	.143	2.1	2.0	11
98	.211	.543	16	.177	1.0	.7	10.5	98	.237	.502	13	.125	2.4	.7	9.5
111	.187	.399	10.5	.107	1.2	1.1	8	111	.2	.476	10.5	.075	1.2	1.1	8
126	.184	.536	12	.118	1.0	.9	9	126	.172	.601	15	.067	.7	.4	8
140	.211	.642	11	.12	1.4	.4	9	140	.233	.667	10.5	.109	3.5	1.4	8.5
154	.262	.656	8.5	.086	.5	.5	6.5	154	.704	.843	5.5	.733	.5	.5	3
168	.185	.518	9.5	.083	2.7	2.3	7	168	.29	.683	22	.441	4.3	2.6	18
189	.154	.488	8	.112	1.0	.9	7.5	189	.274	.464	9.5	.222	3.2	1.4	9

Table C-2. Continued.

Microcosm 5							
Day	TP	TN	TC	TFe	SS	VSS	IC
7	.095	.312	4.8	.017	.05	.05	2.6
13	.047	.808	29.5	.053	10.5	3.0	23.5
27	.072	.195	12.5	.043	11.3	4.7	6.0
42	.037	.246	6.5	.021	7.3	3.0	3.0
56	.039	.055	6.0	.048	5.7	2.0	2
70	.032	.206	6	.014	7.3	3.0	4
84	.041	.34	5	.092	12.7	2.6	3
98	.062	.242	9	.143	18.1	2.5	4.5
111	.054	.197	5.5	.098	19.3	3.4	2.5
126	.052	.103	5.5	.082	17.9	3.6	3.5
140	.064	.517	5	.078	16.5	3.5	3.5
154	.071	.098	5	.125	14.1	3.0	3
168	.075	.075	5.5	.081	13.6	2.5	3
189	.034	.140	4	.051	9.8	2.5	3

Microcosm 7							
Day	TP	TN	TC	TFe	SS	VSS	IC
7	.095	.298	4.3	.017	.05	.05	2.6
13	.056	.97	28.5	.057	11.3	2.7	23.0
27	.039	.440	19.5	.021	5.90	2.3	4.0
42	.055	.277	9.0	.046	17.6	4.5	3.0
56	.198	.722	14.5	.056	14.3	4.7	6.5
70	.126	.551	10	.027	15.2	11.0	5
84	.093	.5	7	.061	23.4	6.3	2.5
98	.066	.458	9	.140	20.1	2.7	2.5
111	.045	.271	5.5	.065	14.9	3.4	2.5
126	.049	.337	5	.088	16.3	2.3	3
140	.056	.616	22	.047	15.1	3.5	15
154	.05	.071	4	.092	11.8	3.0	3
168	.076	.051	7	.121	20.0	3.5	2.5
189	.051	.119	3.5	.049	13.2	1.6	2

Microcosm 6							
Day	TP	TN	TC	TFe	SS	VSS	IC
7	.095	.607	4.8	.017	.05	.05	2.6
13	.050	.629	28.5	.070	13.7	2.7	23.0
27	.026	.380	16.5	.020	3.60	1.6	11.5
42	.046	.281	8.0	.091	23.2	1.0	3.5
56	.371	.806	17.5	.401	233.9	40.1	7
70	.076	.466	7	.071	27.7	6.1	3.5
84	.108	.631	10	.093	24.7	5.5	6
98	.247	.472	19	.233	53.0	12.3	10
111	.189	.716	12	.095	19.6	7.0	11
126	.204	.861	19	.199	62.2	22.9	8.5
140	.32	1.326	17	.234	86.8	26.3	7
154	.218	.322	15	.387	81.2	13.6	6.5
168	.265	.811	24	.241	58.5	16.1	12.5
189	.114	.364	15	.182	22.2	3.8	7

Microcosm 8							
Day	TP	TN	TC	TFe	SS	VSS	IC
7	.095	.595	4.8	.017	.05	.05	2.6
13	.059	.748	27.5	.066	14.3	3.3	21.5
27	.101	.577	13	.066	23.1	0.0	6.5
42	.200	.293	10.0	.146	65.0	6.3	4.0
56	.453	2.440	17.0	.529	157.4	24.1	5.5
70	.045	.197	8	.016	12.8	3.0	3.5
84	.848	.239	6.5	.161	39.5	13.1	2.5
98	.366	1.039	14.5	.478	118.9	26.7	5
111	.206	.472	12	.452	93.6	16.5	6.5
126	.08	.339	6.5	.183	37.1	2.4	3
140	.109	.502	6	.172	65.0	10.6	2.5
154	.088	.120	8	.151	34.8	6.5	3
168	.147	.241	7.5	.147	71.0	11.5	2.5
189	.029	.316	4	.086	17.9	3.0	2

Table C-2. Continued.

Microcosm 9							
Day	TP	TN	TC	TFe	SS	VSS	IC
7	.095	.312	4.8	.017	.05	.05	2.6
13	.035	.740	25.0	.046	7.3	2.7	21.
27	.039	.904	7.0	.029	9.6	3.7	0.5
42	.244	1.06	19.5	.236	116.1	25.0	3.5
56	.400	.604	16	.378	134	29	3
70	.2	.943	15	.088	53.3	27.6	3
84	.243	.935	10	.135	63.4	27.4	2.5
98	.562	.749	19	.515	291.6	60	4
111	.592	1.132	20.5	.749	318.9	71.7	5
126	.383	.941	18	.418	173.7	29.2	8
140	.416	1.228	3.5	.3	190.4	35.7	.5
154	.309	.649	13	.26	113.3	28.7	3
168	.108	.292	7	.1	31.9	10.1	3.5
189	.116	.612	7	.122	37.8	7.5	1.5

Microcosm 11							
Day	TP	TN	TC	TFe	SS	VSS	IC
7	.095	.298	4.8	.017	.05	.05	2.6
13	.040	.539	29.0	.059	7.7	2.6	25.
27	.030	.387	7.5	.036	9.2	4.1	2.5
42	.043	.885	6.5	.020	9.9	3.9	1.0
56	.147	.105	6	.046	12.7	3.5	1.5
70	.026	.696	6.5	.019	10.9	2.7	2.5
84	.076	.614	6	.097	21.7	3.7	2
98	.066	.537	8.5	.187	31.1	4.7	2.5
111	.038	.273	6	.067	14.8	3.0	3
126	.028	.206	3	.017	9.4	2.0	1.5
140	.045	.528	3.5	.04	6.6	2.3	1
154	.029	.213	3	.042	6.7	2.3	2
168	.045	.113	1.5	.024	7.0	1.9	1
189	.01	.142	2.5	.034	3.8	0.9	1

Microcosm 10							
Day	TP	TN	TC	TFe	SS	VSS	IC
7	.095	.607	4.8	.017	.05	.05	2.6
13	.037	.734	27.0	.072	9.9	3.3	22.5
27	.026	.461	6.5	.012	4.0	2.8	.50
42	.061	.648	7.0	.051	17.9	3.9	1.5
56	.127	.111	7	.048	13.0	2.1	1.5
70	.032	.313	7	.018	6.1	2.9	2.5
84	.022	.319	4.5	.025	1.7	.7	2
98	.038	.525	4	.047	7.1	2.0	1.5
111	.047	.232	3.5	.038	4.1	.4	1
126	.014	.239	4	.022	6.3	2.3	1.5
140	.037	.485	3.5	.036	4.0	2.1	1
154	.047	.075	3	.055	9.0	2.0	3
168	.055	.080	2.5	.015	4.4	1.2	2
189	.013	.344	2.5	.008	2.2	.6	1

Microcosm 12							
Day	TP	TN	TC	TFe	SS	VSS	IC
7	.095	.595	4.8	.017	.05	.05	2.6
13	.051	.741	24.0	.064	13.0	4.0	20.5
27	.035	.446	7.0	.028	10.4	5.5	1.0
42	.028	.199	5.0	.0005	3.8	1.4	1.5
56	.057	.172	5	.0005	3.3	2.5	1
70	.016	.369	5	.0005	.5	.5	1.5
84	.014	.520	5	.013	1.5	.5	1.5
98	.016	.521	3.5	.022	3.8	.7	1
111	.024	.197	3	.001	4.5	1.3	1
126	.022	.129	9	.017	2.4	.7	3
140	.036	.638	4	.016	4.7	1.3	.5
154	.085	.470	7.5	.026	10.9	6.3	2.5
168	.043	.106	2.5	.0005	3.1	1.9	1
189	.006	.276	2.5	.007	1.9	0.2	1

Table C-2. Continued.

Microcosm 13								Microcosm 15							
Day	TP	TN	TC	TFe	SS	VSS	IC	Day	TP	TN	TC	TFe	SS	VSS	IC
7	.095	.312	4.8	.017	.05	.05	2.6	7	.095	.298	4.8	.017	.05	.05	2.6
13	.041	.701	30.0	.062	11.0	1.4	26.0	13	.050	.385	28.0	.063	11.9	3.9	24.5
27	.036	.411	10.0	.016	6.0	2.0	5.5	27	.057	.395	11.5	.028	9.7	5.4	6.0
42	.034	.01	9.0	.0340	8.9	.01	3.0	42	.045	.177	9.0	.0370	12.9	5.6	2.5
56	.059	.056	6	.054	13.0	2.9	2.5	56	.059	.256	8	.052	15.1	3.4	2
70	.057	.055	7	.048	16.3	3.7	2.5	70	.031	.119	7	.001	6.2	2.0	2
84	.055	.781	5	.051	10.4	3.3	2.5	84	.065	.490	6.5	.099	25.3	2.3	3
98	.046	.760	5.5	.148	22.8	3.0	3	98	.066	.315	6.5	.198	24.3	3.0	3
111	.062	.198	6	.141	22.2	2.8	3	111	.038	.16	7	.078	12.7	2.3	4
126	.088	.248	6	.074	14.5	2.7	2.5	126	.036	.16	4.5	.034	5.6	1.6	2
140	.039	.586	4.5	.04	6.8	1.8	1.5	140	.036	.245	6.5	.055	9.9	2.8	2
154	.038	.064	5	.058	10.0	2.6	3	154	.026	.043	6	.068	10.7	3.0	3
168	.058	.036	2.5	.041	9.1	1.8	2.5	168	.032	.072	6.5	.074	13.6	3.0	3
189	.023	.315	3.5	.042	7.0	.9	2	189	.02	.102	5	.077	8.6	3.7	2

Microcosm 14								Microcosm 16							
Day	TP	TN	TC	TFe	SS	VSS	IC	Day	TP	TN	TC	TFe	SS	VSS	IC
7	.095	.607	4.8	.017	.05	.05	2.6	7	.095	.595	4.8	.017	.05	.05	2.6
13	.047	.499	25.0	.063	11.4	3.5	21.0	13	.068	.596	25.0	.075	18.6	5.1	22.0
27	.044	.258	8.0	.040	9.5	4.9	4.0	27	.041	.320	9.0	.024	5.9	3.5	5.5
42	.022	.022	6.0	.0130	6.4	.7	2.0	42	.037	.167	6.5	.018	7.8	.9	3.0
56	.049	.257	5	.040	9.5	2.5	2	56	.116	.149	6	.006	5.7	2.0	2
70	.039	.194	6.5	.033	17.7	3.4	3	70	.032	.152	7	.030	1.7	1.4	4
84	.093	.535	5.5	.108	29.4	4.2	2.5	84	.02	.554	4.5	.002	2.6	1.7	2.5
98	.08	.701	7.5	.202	34.8	5.3	4	98	.032	.447	4.5	.028	4.0	2.0	2
111	.076	.292	6.5	.124	26.6	2.8	3.5	111	.041	.176	6.5	.027	8.0	2.5	4
126	.054	.227	4.5	.088	21.0	3.6	2.5	126	.023	.265	3.5	.02	2.1	.4	3
140	.063	.412	6	.082	21.0	3.0	2	140	.02	.418	3.5	.015	2.2	2.0	1
154	.046	.07	7.5	.079	16.4	3.1	4	154	.013	.056	5	.014	.7	.01	3
168	.056	.188	3	.062	15.8	3.3	3	168	.031	.033	5	.0005	2.7	1.4	3
189	.021	.119	4	.042	7.4	.6	2	189	.006	.144	5	.012	2.9	1.1	2

Table C-2. Continued.

Filtered

Day	Microcosm 1						TFe
	PO ₄ P	TP	NO ₂ -N	NO ₃ -N	NH ₃ -N	TC	
7	.080	.082	.0005	.008	.061	4.8	.011
13	.065	.067	.003	.021	.590	26.5	.018
27	.220	.268	.0010	.019	.565	14.0	.013
42	.275	.268	.001	.007	.415	14.0	.078
56	.193	.218	.0005	.005	.345	12.5	.043
70	.182	.186	.0005	.006	.535	13	.012
84	.173	.180	.002	.056	.570	11	.093
98	.166	.155	.0005	.004	.441	10	.036
111	.128	.137	.0005	.0005	.352	10	.045
126	.152	.144	.0005	.004	.148	7	.096
140	.136	.139	.0005	.0005	.363	7.5	.118
154	.11	.131	.0005	.005	.598	12	.02
168	.147	.136	.0005	.007	.529	7	.136
189	.102	.103	.0005	.011	.45	6	.036

Day	Microcosm 3						TFe
	PO ₄ P	TP	NO ₂ -N	NO ₃ -N	NH ₃ -N	TC	
7	.080	.082	.0005	.008	.061	4.8	.011
13	.060	.052	.002	.114	.220	26.5	.019
27	.236	.255	.0005	.006	.205	16.0	.126
42	.194	.187	.001	.001	.485	16.5	.013
56	.179	.216	.0020	.008	.485	15.0	.028
70	.141	.146	.0005	.004	.527	13.5	.033
84	.130	.143	.0005	.005	.405	12	.046
98	.175	.166	.0005	.004	.379	12	.135
111	.15	.149	.0005	.002	.426	9.5	.07
126	.167	.158	.0005	.008	.566	7	.083
140	.147	.139	.0005	.005	.382	7.5	.066
154	.149	.171	.0005	.005	.586	8	.073
168	.14	.131	.0005	.016	.491	12	.061
189	.129	.137	.0005	.003	.405	6.5	.074

Day	Microcosm 2						TFe
	PO ₄ P	TP	NO ₂ -N	NO ₃ -N	NH ₃ -N	TC	
7	.080	.082	.0005	.314	.061	4.8	.011
13	.060	.063	.003	.136	.495	32.0	.017
27	.370	.386	.0005	.032	.365	17.0	.254
42	.237	.220	.002	.001	.545	16.0	.022
56	.227	.286	.0020	.008	.490	18.0	.155
70	.155	.148	.0005	.0005	.221	13	.036
84	.158	.185	.001	.003	.420	14	.109
98	.194	.193	.0005	.002	.541	11.5	.169
111	.155	.149	.0005	.0005	.384	10.5	.125
126	.165	.154	.0005	.004	.532	8	.116
140	.156	.161	.0005	.001	.489	9	.143
154	.157	.173	.0005	.004	.652	8.5	.079
168	.136	.124	.0005	.006	.512	8	.088
189	.132	.133	.0005	.003	.485	7	.095

Day	Microcosm 4						TFe
	PO ₄ P	TP	NO ₂ -N	NO ₃ -N	NH ₃ -N	TC	
7	.080	.082	.0005	.314	.061	4.8	.011
13	.056	.050	.002	.189	.525	27.5	.021
27	.173	.193	.0030	.022	.435	16.5	.012
42	.237	.222	.002	.0005	.455	15.	.075
56	.201	.218	.0010	.004	.535	14.0	.152
70	.148	.135	.0005	.001	.586	13.5	.021
84	.130	.143	.0005	.003	.405	12.5	.039
98	.156	.147	.0005	.002	.5	11	.066
111	.135	.138	.0005	.002	.474	9	.036
126	.136	.133	.0005	.003	.598	9	.024
140	.11	.111	.0005	.0005	.539	8	.052
154	.649	.711	.0005	.001	.842	4.5	.649
168	.086	.087	.0005	.005	.567	22	.16
189	.163	.169	.0005	.004	.405	8	.088

Table C-2. Continued.

Microcosm 5								Microcosm 7							
Day	PO ₄ P	TP	NO ₂ -N	NO ₃ -N	NH ₃ -N	TC	TFe	Day	PO ₄ P	TP	NO ₂ -N	NO ₃ -N	NH ₃ -N	TC	TFe
7	.080	.082	.0005	.008	.061	4.8	.011	7	.080	.082	.0005	.008	.061	4.6	.011
13	.002	.009	.0005	.003	.023	25.5	.015	13	.004	.012	.0005	.010	.015	29.5	.019
27	.026	.045	.0005	.005	.030	8.0	.0005	27	.016	.021	.0005	.003	.019	5.0	.002
42	.006	.040	.002	.0005	.024	7.5	.0005	42	.013	.018	.002	.0005	.020	6.5	.0005
56	.008	.027	.0005	.007	.015	6.5	.0005	56	.063	.104	.001	.004	.028	11.5	.0005
70	.013	.022	.0005	.004	.055	6	.0005	70	.007	.029	.001	.001	.02	9	.0005
84	.02	.031	.001	.007	.054	5.5	.013	84	.007	.025	.0005	.005	.022	5	.012
98	.02	.022	.004	.0005	.05	7	.061	98	.01	.012	.002	.0005	.040	6	.042
111	.014	.02	.001	.001	.046	5.5	.03	111	.008	.016	.0005	.003	.029	6	.025
126	.013	.016	.001	.001	.074	5	.016	126	.009	.01	.002	.0005	.078	4	.027
140	.008	.008	.0005	.0005	.053	5	.019	140	.0005	.008	.0005	.0005	.048	22	.052
154	.021	.028	.0005	.004	.072	5	.041	154	.014	.018	.0005	.006	.065	3.5	.021
168	.027	.032	.0005	.006	.069	3.5	.014	168	.021	.039	.0005	.007	.044	3	.011
189	.007	.02	.0005	.003	.049	3	.012	189	.004	.02	.0005	.003	.038	3	.009

Microcosm 6								Microcosm 8							
Day	PO ₄ P	TP	NO ₂ -N	NO ₃ -N	NH ₃ -N	TC	TFe	Day	PO ₄ P	TP	NO ₂ -N	NO ₃ -N	NH ₃ -N	TC	TFe
7	.080	.082	.0005	.014	.061	4.8	.011	7	.080	.082	.0005	.014	.061	4.8	.011
13	.002	.008	.0005	.010	.026	28.0	.018	13	.004	.008	.0010	.014	.031	25.0	.025
27	.016	.030	.0005	.013	.016	12.5	.0210	27	.014	.025	.0005	.009	.022	9.5	.009
42	.013	.026	.0020	.0005	.020	9.0	.0005	42	.038	.049	.003	.0005	.026	7.5	.020
56	.062	.094	.011	.0005	.09	13.5	.118	56	.115	.139	.013	2.195	.062	12	.142
70	.015	.032	.002	.0005	.039	6.5	.011	70	.011	.028	.0005	.0005	.025	8	.0305
84	.044	.066	.002	.005	.076	9.5	.024	84	.01	.032	.001	.003	.054	5	.007
98	.108	.117	.006	.0005	.118	15.5	.099	98	.053	.068	.11	.0005	.118	15.5	.146
111	.002	.107	.0005	.003	.067	13.5	.022	111	.04	.062	.0005	.003	.017	5	.135
126	.011	.022	.003	.0005	.07	14	.054	126	.037	.046	.004	.0005	.076	4.5	.081
140	.029	.035	.0005	.0005	.053	21.5	.12	140	.009	.019	.0005	.003	.054	5	.049
154	.062	.069	.0005	.022	.084	14	.193	154	.028	.031	.0005	.009	.056	3	.074
168	.054	.071	.0005	.008	.043	14.5	.096	168	.045	.069	.0005	.009	.064	3	.082
189	.002	.011	.0005	.002	.033	7	.041	189	.005	.013	.0005	.002	.046	3	.008

Table C-2. Continued.

Microcosm 9							
Day	PO ₄ P	TP	NO ₂ -N	NO ₃ -N	NH ₃ -N	TC	TFe
7	.080	.082	.0005	.008	.061	4.8	.011
13	.002	.005	.0010	.0005	.011	24.0	.015
27	.012	.022	.0005	.004	.041	6.0	.009
42	.018	.043	.001	.0005	.015	8.0	.032
56	.029	.078	.007	.002	.055	8	.055
70	.013	.032	.001	.005	.039	8	.0005
84	.005	.015	.002	.002	.041	6.5	.021
98	.022	.073	.015	.0005	.007	9	.240
111	.016	.051	.0005	.005	.064	5.5	.127
126	.073	.099	.013	.0005	.127	11	.24
140	.033	.055	.0005	.0005	.069	3.5	.199
154	.03	.043	.0005	.011	.081	6	.087
168	.008	.029	.0005	.003	.065	8.5	.001
189	.004	.013	.0005	.002	.042	7	.014

Microcosm 11							
Day	PO ₄ P	TP	NO ₂ -N	NO ₃ -N	NH ₃ -N	TC	TFe
7	.080	.082	.0005	.008	.061	4.8	.011
13	.009	.013	.0010	.0020	.008	23.5	.035
27	.007	.014	.0005	.003	.026	7.0	.0005
42	.002	.006	.0035	.0005	.010	6.0	.0005
56	.003	.022	.001	.003	.019	6	.0005
70	.016	.018	.0005	.0005	.021	5.5	.0005
84	.013	.017	.002	.003	.037	4.5	.028
98	.027	.031	.005	.001	.09	8	.078
111	.006	.012	.0005	.002	.042	3.5	.03
126	.004	.004	.0005	.0005	.054	3	.01
140	.0005	.004	.0005	.0005	.036	3.5	.012
154	.004	.015	.0005	.005	.074	3	.0005
168	.005	.02	.0005	.002	.038	2	.0005
189	.0005	.01	.0005	.002	.072	2.5	.0005

Microcosm 10							
Day	PO ₄ P	TP	NO ₂ -N	NO ₃ -N	NH ₃ -N	TC	TFe
7	.080	.082	.0005	.314	.061	4.8	.011
13	.004	.010	.0010	.0180	.015	26.0	.022
27	.006	.030	.0005	.008	.026	6.0	.011
42	.003	.041	.0005	.0005	.009	5.0	.0005
56	.013	.022	.001	.003	.015	8	.0005
70	.016	.018	.0005	.0005	.026	5.5	.011
84	.0005	.006	.0005	.0005	.027	4	.001
98	.007	.008	.0005	.0005	.037	3.5	.020
111	.001	.009	.0005	.002	.024	5.5	.01
126	.004	.004	.0005	.002	.057	3	.013
140	.0005	.0005	.0005	.004	.04	3.5	.008
154	.008	.01	.0005	.006	.069	4	.006
168	.003	.023	.0005	.004	.045	4.5	.0005
189	.001	.011	.0005	.004	.059	2.5	.0005

Microcosm 12							
Day	PO ₄ P	TP	NO ₂ -N	NO ₃ -N	NH ₃ -N	TC	TFe
7	.080	.082	.0005	.314	.061	4.8	.011
13	.004	.008	.0005	.0130	.019	24.0	.021
27	.005	.011	.0005	.011	.016	5.5	.0070
42	.007	.015	.0005	.0005	.018	5.0	.0005
56	.0005	.020	.001	.003	.015	5.5	.0005
70	.013	.011	.0005	.0005	.017	6	.0005
84	.0005	.004	.0005	.001	.039	3.5	.0005
98	.005	.007	.0005	.002	.058	3	.004
111	.003	.009	.0005	.002	.026	3	.0005
126	.0005	.0005	.0005	.0005	.062	3	.001
140	.0005	.003	.0005	.0005	.03	3.5	.016
154	.029	.056	.0005	.008	.066	5	.0005
168	.006	.029	.0005	.003	.038	2.5	.0005
189	.0005	.01	.0005	.003	.062	2.5	.0005

Table C-2. Continued.

Microcosm 13								Microcosm 15							
Day	PO ₄ P	TP	NO ₂ -N	NO ₃ -N	NH ₃ -N	TC	TFe	Day	PO ₄ P	TP	NO ₂ -N	NO ₃ -N	NH ₃ -N	TC	TFe
7	.080	.082	.0005	.008	.061	4.8	.011	7	.080	.082	.0005	.008	.061	4.8	.011
13	.009	.015	.0020	.0005	.032	30.0	.025	13	.004	.010	.0020	.0020	.014	29.0	.030
27	.009	.019	.0005	.0003	.016	9.5	.003	27	.010	.017	.0005	.0003	.016	9.0	.011
42	.008	.016	.0005	.0005	.008	6.0	.0005	42	.007	.016	.0005	.002	.007	7.0	.0005
56	.011	.018	.002	.001	.035	6	.0005	56	.008	.02	.0005	.003	.019	6	.0005
70	.024	.032	.004	.0005	.051	6.5	.007	70	.004	.016	.0005	.0005	.049	6	.0005
84	.008	.006	.0005	.0003	.02	5	.0005	84	.017	.018	.002	.0005	.025	5	.015
98	.015	.019	.004	.0005	.041	5.5	.0005	98	.033	.037	.007	.0005	.049	5	.005
111	.02	.026	.003	.0005	.028	5.5	.034	111	.006	.018	.0005	.0005	.021	6	.027
126	.009	.009	.0005	.0005	.058	3	.018	126	.0005	.0005	.0005	.0005	.05	4.5	.011
140	.0005	.0005	.0005	.01	.033	3.5	.011	140	.0005	.003	.0005	.004	.036	3.5	.024
154	.009	.015	.0005	.005	.059	3.5	.006	154	.009	.009	.0005	.003	.04	3.5	.010
168	.015	.031	.0005	.003	.033	2.5	.002	168	.008	.028	.0005	.002	.022	6.5	.013
189	.006	.023	.0005	.001	.045	3	.016	189	.003	.013	.0005	.0005	.036	3	.011

Microcosm 14								Microcosm 16							
Day	PO ₄ P	TP	NO ₂ -N	NO ₃ -N	NH ₃ -N	TC	TFe	Day	PO ₄ P	TP	NO ₂ -N	NO ₃ -N	NH ₃ -N	TC	TFe
7	.080	.082	.0005	.314	.061	4.8	.011	7	.080	.082	.0005	.314	.061	4.8	.011
13	.005	.012	.0020	.0140	.036	24.5	.025	13	.007	.013	.0005	.0120	.026	28.0	.0230
27	.006	.016	.0005	.008	.019	7.0	.005	27	.009	.016	.0005	.013	.020	10.0	.005
42	.006	.017	.0005	.0005	.017	5.0	.0005	42	.009	.018	.0010	.0005	.026	6.5	.0005
56	.0005	.02	.001	.008	.013	6	.0005	56	.002	.027	.002	.019	.019	6	.001
70	.013	.022	.001	.0005	.015	7.5	.001	70	.004	.022	.0005	.0005	.152	6.5	.0005
84	.016	.02	.002	.001	.024	5	.008	84	.004	.009	.0005	.005	.036	5	.0005
98	.033	.042	.008	.0005	.073	5.5	.093	98	.005	.005	.0005	.003	.033	3.5	.007
111	.019	.035	.001	.0005	.032	6	.029	111	.003	.018	.0005	.0005	.019	6	.054
126	.006	.006	.0005	.0005	.063	4	.023	126	.004	.009	.0005	.0005	.073	3.5	.01
140	.0005	.001	.001	.01	.052	3.5	.033	140	.0005	.009	.0005	.003	.046	3.5	.02
154	.001	.009	.0005	.005	.065	3.5	.013	154	.002	.002	.0005	.003	.053	5	.0005
168	.008	.029	.0005	.004	.038	3	.004	168	.003	.024	.0005	.004	.029	5	.0005
189	.004	.014	.0005	.006	.047	3.5	.007	189	.0005	.006	.0005	.002	.047	2.5	.008

Table C-3. Atmospheric pressure, room temperature, effluent temperature for specific Microcosms 1-16.

Day	Atm P	RT	M	1 9	2 10	3 11	4 12	5 13	6 14	7 15	8 16
8	635.	20.5		20.5	20.5	20.5	20.5	20.5	20.5	20.5	20.5
9	640.	20.		20.5	20.5	20.5	20.5	20.5	20.5	20.5	20.5
10	648.2	20.2		20.2	20.2	20.2	20.2	20.2	20.2	20.2	20.2
11	645.	20.		20.	20.	20.	20.	20.	20.	20.	20.
12	644.5	21.		19.1	19.1	19.1	19.1	20.5	20.5	20.5	20.5
13	647.2	23		20.5	20.5	20.5	20.5	22	22	22	22
14	650.	22.		19.5	19.5	19.5	19.5	21.	21.	21.	21.
15	655.5	21.5		20	20	20	20	20	20	20	20
16	653.2	22.2		21.5	21.5	21.5	21.5	22.5	22.5	22.5	22.5
17	649.4	23		22	22	22	22	23	23	23	23
18	649.6	23.9		22.5	22.5	22.5	22.5	23.2	23.2	23.2	23.2
19	646.6	23.2		22.5	22.5	22.5	22.5	23.2	23.2	23.2	23.2
20	659	23		22	22	22	22	23	23	23	23
21	645.6	23.4		22.5	22.5	22.5	22.5	23.2	23.2	23.2	23.2
22	636	24.2		22.5	22.5	22.5	22.5	23.2	23.2	23.2	23.2
23	647.9	23		21	21	21	21	23	23	23	23
24	645	23.3		21	21	21	21	22.5	22.5	22.5	22.5
25	654.3	23.5		21	21	21	21	22.5	22.5	22.5	22.5
26	653.5	22.5		20	20	20	20	21.5	21.5	21.5	21.5
27	640.3	23		21	20.5	20.5	21	22	23	23	23
28	637.5	22.5		22	22	22	22	23	23	23	23
29	637.2	23		21.5	21.5	21.5	21.5	23	23	23	23
30	647.9	23		21.5	21.5	21.5	21.5	23	23	23	23
31	644.9	23		21.5	21.5	21.5	21.5	23	23	23	23

Table C-3. Continued.

Day	Atm P	RT	M 1 9	2 10	3 11	4 12	5 13	6 14	7 15	8 16
32	651	22.5	21	21	21	21	22.5	22.5	22.5	23
			25	25	25	25	23	23	23	23
33	642.4	22.5	21	21.2	20.8	21	22.3	22.6	22.8	23
			24.3	25	25	25	23	23.5	23.1	23
34	636.4	23	21.5	21.6	21	21.5	22.5	23	23	23.6
			24.7	25	25	25	23	23.5	23.2	23.1
35	643.5	23.5	21.5	21.2	21.1	21.2	22.8	23	23.2	23.5
			24.6	25.2	25.1	25.1	23.4	23.6	23.5	23.2
36	643.9	23	22	21.8	21.6	21.5	23.4	23.9	24	24.2
			25.2	26.2	25.8	25.5	23.6	23.7	23.9	23.5
37	644.2	22.7	22.5	22.9	22.9	23.6	22.5	24.9	24	24.2
			25.2	25.4	25.3	25.2	23.3	23.6	23.6	23.5
38	643.7	25	24.9	25	25.3	25.8	25.2	25.6	25.8	26
			26.8	23	26.2	27	25.8	26.1	26.2	26
39	643.5	24.9	24.5	25.0	25.0	25.5	25.0	25.5	25.5	25.8
			26.8	26.9	27.5	27.0	25.5	25.6	26.0	26.0
40	641.8	23.8	24	24	24	24.3	24	24.5	24.5	24.8
			25.5	25.8	25.8	26	24.6	25	25.2	25
41	645	22	22.5	22.5	22.8	23.0	23.0	23.2	23.2	23.5
			24.0	24.5	24.5	24.8	23.2	23.5	23.8	24.0
42	650.6	25	23	23	22.5	22.5	23.1	25.5	25.5	25.5
			26.2	27	27	27	25.5	25.5	25	25.5
43	646.4	23.8	22	22.2	22	22	23.8	24	24	24.2
			25.5	25.8	26.3	26	24.2	24.5	24.5	24.5
44	649.8	24.1	23	23.5	23.3	24	24	24	24.8	24.8
			25.5	25.6	25.8	25.8	24.2	24.5	24.5	24.5
45	651.3	24.3	23	23.2	23.5	24	24	24.4	24.8	25
			24.5	26	26	26	24.5	24.8	24.6	25
46	645.5	24	23	23.5	23	24.2	23.5	24	24.3	24.5
			25.5	25.5	25.7	26	24.5	24.5	24.6	24.5
47	637.7	25	24.8	24.9	24.5	25.5	25.7	25.8	25.8	26
			26.4	27	26.9	27	24.8	26	26.2	26.3
48	637.2	25.2	23.9	24.1	24.5	24.8	25	25.2	25.2	25.3
			29	28.1	27	26.8	25.4	25.6	25.2	25.2
49	640.6	25	24	24.5	24.5	25	25.5	25.5	25.8	25.5
			27	27.3	27	27.1	25	25.3	25	25.1
50	633.9	23	22.8	23	23.2	24.9	23.2	23.8	23.8	24
			24.8	25	25	25	23.5	23.8	24.1	23.8
51	643.7	24.5	24.2	24.5	24.5	25.5	24.5	25	25.2	25.5
			26	26.2	26.5	26.5	25.5	25.5	25.5	25.5
52	641.3	25.5	24.5	25	25.2	26	25	25.5	25.8	26
			26.8	27	26.8	27	25.6	26	26	25.8
53	648.1	25.1	24.5	25	25.2	25.8	25	25.2	25.5	25.7
			26.4	26.6	26.5	27	25.2	25.8	25.8	25.2
54	653.3	24.2	23.8	24	24.5	25	24.2	24.6	24.6	24.7
			25.7	25.8	25.8	26	24.5	24.9	25.1	24.8
55	650	23.5	23.9	23.4	23.5	24.1	23.5	23.6	23.5	24.1
			24.9	24.9	24.9	25.2	23.8	24.1	23.9	23.8

Table C-3. Continued.

Day	Atm P	RT	M 1 9	2 10	3 11	4 12	5 13	6 14	7 15	8 16
56	642.7	25	24.9	25	25.2	26	25.2	25.4	25.7	26.1
			26.8	26.9	26.8	27.1	25.8	26	26	25.8
57	640.8	25.1	24.8	24.9	25.1	25.8	25.3	25.7	25.6	26
			26.8	27	26.9	27	25.9	26.1	26	25.8
58	653.4	25.1	25	25	25.4	26	25.2	25.4	25.8	26
			26.8	27	27	27	25.8	25.2	26	25.8
59	654.1	25	25	25	25.2	26	25.2	25.7	25.6	26
			26.6	26.8	26.8	27	26	26	25	25.8
60	645.8	24.9	24.5	25	25	25.6	25	25.5	25.5	25.8
			26.5	26.5	26.5	27	25.5	26	25.8	25.5
61	638.1	25.4	24	24.5	24.8	25.3	25	25.5	25.5	26
			26	26.5	26.2	26.5	25.8	26	25.6	25.7
62	638.1	25.7	25	25	25.5	26	25	25.7	25.4	25.9
			27	27	27	27	25.4	25.7	25.6	25.2
63	647.5	25	24.5	24.8	25	25.5	24.5	24.5	25	25.2
			26.5	26.5	26.5	26.8	25	25.7	25	25
64	650	25	24.2	24.7	24.8	25.4	24	24.7	24.1	24.5
			26.4	26.4	26.5	26.7	24.7	26	24.8	24.5
65	643.7	25	24.2	24.5	25	25.2	24.4	24.6	25	25.2
			26.3	26.4	26.4	27	24.8	25	26	24.8
66	643	24.9	24.5	25	24.4	25.7	24.7	25	25.8	25.5
			26.6	26.8	26.2	27	25	25.2	25.8	25
67	645.7	25.5	24.1	24.6	24.5	25.9	26.1	25.2	24.8	25.2
			26.3	26.8	26.1	26.2	25.5	25.8	25	25
68	641.5	25	24.3	24.6	24.8	25.4	24.6	25	25	25.1
			26.2	26.9	26.5	26.9	24.9	25	25.1	24.9
69	643.7	25.6	23.9	24.1	25.1	25.5	25.2	25.5	25	25.4
			25.9	26.5	26.7	27.1	25.5	25.6	25.1	25
70	643.4	24.1	23.2	23.5	23.9	24.3	23.2	23.6	23.9	24.2
			25	25.7	25.5	25.8	23.6	23.7	23.8	23.8
71	646.7	23.8	22	22.5	22.8	22.8	23.4	23.8	24	25.8
			24.1	24.6	24.5	25.1	24.7	24.6	24	23.8
72	638.5	24.4	23	23	23.2	24	24	24.2	24.4	24.8
			24.8	25.2	25	25.2	24	24.2	24.5	24.2
73	633.3	24.4	23.4	23.9	24.1	24.2	23.3	23.9	24	25
			25.4	26.1	25.6	25.5	23.9	24	24	24.5
74	635	25.1	24	24.3	24.8	25.3	24	24.5	24.5	25
			26.2	26.5	25.2	26.7	24.5	24.5	24.3	24.5
75	642.3	24.7	24.2	24.5	24.8	25.2	24	24.5	24.5	25
			26	26.7	25.2	26.5	24.6	24.7	24.7	24.5
76	645.6	25	24	24.5	24.9	25.3	24	24.5	24.6	25
			26	26.5	26	25.5	24.5	24.5	24.6	24.5
77	648.9	24.3	23.5	24	25	25.3	25	25	25	25
			25.5	25	26	26.5	25.2	25.2	24.8	24.7
78	649.5	25	24.5	24.5	25	25.2	24.8	24.5	24.5	25
			26	26.5	25.2	26.5	24.5	24.8	25	24.8
79	648.4	25	23.7	24	24.3	25	25	25.2	25.5	25.7
			25.8	26.2	25	26.2	25.2	25.2	25.5	25.2

Table C-3. Continued.

Day	Atm P	RT	M 1 9	2 10	3 11	4 12	5 13	6 14	7 15	8 16
80	645.8	24.7	23.7 25.5	24 26	24.2 25.9	24.8 26	25 25	25 25.2	25 25.4	25.3 25
81	650.7	24.1	24 26	24.3 25.3	24.2 25.7	24.8 26	24.2 24.7	24.7 24.8	25 25	24.9 25
82	650.9	24.2	24.2 26	24.2 26.4	24.9 25.2	25.1 26.5	24.7 24.8	24.6 25	24.8 25	25 24.6
83	650.5	24.1	23.7 25.7	24 26.1	24 26	24.7 26.2	24 24	24 24.2	24 24.4	24.3 24.2
84	646	24.5	24.2 26.4	24.5 26.4	24.9 25.2	24.2 25.6	24.3 24	24.8 24.9	24.7 25	25 24.7
85	645.3	24.5	24.2 26.4	24.5 26.4	24.9 26.2	24.2 26.6	24.3 24	24.8 24.9	24.7 25	25 24.7
86	643.4	25	24.1 26	24.5 26.3	24 25.7	24.8 26	24.5 25	24.5 25	25 25.4	25.3 25
87	647.5	25.3	24.1 26.8	24.6 26.8	24.1 26	24.8 26.2	24.6 25	24.6 25	25.2 25.7	25.3 25.2
88	648.3	24.8	23.8 26	24.1 26.4	24.5 26.2	25 26.4	25 25.4	24.4 25	24.8 25	24.8 24.5
89	643.8	25	24 26.7	24.5 26.6	24.8 26.3	25 27	24.8 25	24.8 25	25 25	25 25
90	638.6	25	24 26.5	24.5 26.5	24.8 26.5	25.2 26.5	24.5 25	24.7 25	24.8 25	24.9 24.8
91	643.8	25	24.2 26.3	24.5 26.3	24.8 26.2	25.2 26.4	24.5 25	24.5 25	24.8 25	24.9 24.8
92	643.8	25	24 26.2	24.2 26.2	24.8 26	25.2 26.2	24.3 24.8	24.5 24.8	24.8 25	24.8 24.5
93	647	24.3	24 26.5	24.5 26.5	24 26	24.3 26	24.5 24.8	24.5 25	25 24.5	25 25.3
94	636.4	25	24 26.5	24.4 26.5	24.6 26.5	25 26.8	24.5 25	24.5 25	24.7 25.2	25 24.8
95	636	24.2	24 26.2	24.1 26.2	24.7 26.1	25.2 26.3	24.3 24.9	24.2 24.9	24.3 24.9	24.8 24.5
96	639.5	24.3	24.1 26.5	24.4 26.5	25 26.4	25.4 26.8	24.2 25	24.6 25.2	24.9 25	25 24.8
97	640.6	25	24.2 26.5	24.7 26.3	25 26.2	25.4 26.6	24.6 24	24.6 25	24.7 25	25 24.8
98	641.1	24.7	23.7 25.9	24.5 26	24.8 25.2	25 26.1	25 25	24.9 25.6	24.8 25.1	26.8 24.8
99	638.7	24.8	23.3 25.6	23.9 25.7	24.2 25.5	24.8 25.8	23.8 25.3	25 26.2	25 25.4	25.2 25
100	638.7	24.5	23.8 25.8	23.8 26.2	24.1 25.6	24.6 25.9	24.1 24.8	24.5 24.8	24.5 24.8	24.1 24.5
101	633.4	24.1	23.4 24.5	23.2 25	23.9 25.4	24.5 25.8	24 24.2	24.2 24.5	24.4 24.1	24.5 24.4
102	637.6	24	22.9 25.1	23.2 25	23.5 24.8	24 25.2	23.6 24.1	23.7 24.1	23.8 24.1	24 24.1
103	632.2	25	23.4 26	24 26	24.1 25.8	24.8 26.1	24.2 25.1	24.5 25	24.5 25.3	24.9 24.9

Table C-3. Continued.

Day	Atm P	RT	M 1 9	2 10	3 11	4 12	5 13	6 14	7 15	8 16
104	638.3	24.2	23.1	23.9	24	24.6	24	24.4	24.5	24.6
			25.8	25.7	25.6	25.9	24.6	24.6	24.7	24.7
105	645.9	26.1	25	25.2	25.5	26.2	25.8	25.9	26.1	26.4
			27.2	27.2	27	27.3	26.3	25.4	26.5	26.3
106	647.9	24.2	24.4	24.5	24.6	25.2	25.2	25.1	25.2	25.4
			25.9	26.3	25.2	26.4	25.4	25.5	25.6	25.4
107	638.3	25.4	24.2	24.4	24.7	25.2	24.8	25	25.2	25.4
			26.5	26.3	25.4	26.6	25.5	26.6	25.6	25.5
108	640	25.4	24.1	24.4	24.6	25.2	24.8	25	25.1	25.2
			26.4	26.2	26.1	26.4	25.3	25.4	25.4	25.1
109	642.7	24.8	23.6	24	24.2	24.8	24.2	24.6	24.8	24.9
			25.8	25.7	25.6	26	24.6	24.9	25	24.8
110	636.8	24.8	24	24.2	24.5	25	24.6	24.8	25.2	25.3
			26.3	26.2	26	26.4	25.1	25.2	25.4	25
111	632.3	25.3	24.2	24.4	24.7	25.3	24.8	25.1	25.2	25.4
			26.5	26.4	26.2	26.6	25.5	25.5	25.7	25.4
112	634.3	24.5	23.6	24	24.3	24.8	24.1	24.4	24.6	24.7
			25.9	25.7	25.6	26	24.7	24.7	24.8	24.5
113	642	25.5	23.6	24	24.2	24.8	24.4	24.2	25	25.1
			26.2	26.1	26	26.4	25.2	25.2	25.4	24.9
114	646.3	25.1	24.1	24.4	24.6	25.2	24.9	25.1	25.2	25.5
			26.4	26.3	26.2	26.6	25.4	25.3	25.6	25.2
115	643.3	25.1	24.1	24.5	24.5	25.2	24.8	25.1	25.1	25.4
			26.3	26.2	26.1	26.5	25.4	25.5	25.6	25.2
116	638.8	24.6	23.9	24.3	24.4	24.9	24.6	24.9	25	25.2
			26	26	25.9	26.2	25.2	25.3	25.3	25
117	635.7	25.1	24.3	24.7	24.8	25.4	25.1	25.3	25.5	25.7
			26.7	26.5	26.5	26.7	25.8	25.8	25.3	25.5
118	635.6	24.9	24	24.4	24.6	25.2	24.8	25	25.2	25.4
			26.4	26.2	26.1	26.5	25.4	25.4	25.6	25.2
119	639.9	24.6	23.7	24.1	24.3	24.9	24.5	24.7	24.8	25.1
			26	25.9	26	26.2	25.1	25	25.3	24.9
120	641	25	23.9	24.3	24.4	25.1	24.8	24.9	25	25.3
			26.2	26.1	26	26.4	25.3	25.4	25.5	25.2
121	641.4	25.2	24.3	24.5	24.8	25.2	24.9	25.1	25.3	25.5
			26.6	26.5	26.5	26.7	25.5	25.6	25.8	25.3
122	638.7	24.5	24.1	24.3	24.5	25.1	24.6	25	24.9	25.2
			26.2	26.2	26.1	26.4	25.2	25.3	25.4	25.1
123	644.2	24.9	24.3	23.9	24.1	24.7	24.6	24.7	24.5	24.9
			25.9	25.9	25.8	26.1	25	25	25.2	24.8
124	651.6	25	24.2	24.5	24.8	25.2	25	25.2	25.1	25.4
			26.6	26.5	26.3	26.6	25.6	25.6	25.8	25.4
125	651.4	25.3	24.3	24.7	24.7	25.5	25	25.1	25.3	25.6
			26.6	26.5	26.4	26.8	25.7	25.8	25.8	25.5
126	646.3	26.1	24.5	24.8	24.8	25.5	25.2	25.5	25.4	25.7
			26.7	26.7	26.5	26.9	25.8	25.9	26	25.7
127	640.8	26.8	25	25.3	25.4	26.1	25.2	26.2	26.3	26.6
			27.1	27.5	27.4	27.6	26.6	26.7	26.8	26.4

Table C-3. Continued.

Day	Atm P	RT	M 1 9	2 10	3 11	4 12	5 13	6 14	7 15	8 16
128	645	25.8	24.8 26.7	25 26.6	25.4 25.6	25.8 26.9	25.8 25.8	25.7 25.5	25.8 25	26.2 25.7
129	648	25.4	23.8 25.6	24.1 25.5	24.5 25.4	25.1 25.8	24.6 24.8	24.7 24.6	24.8 25	25.2 24.3
130	644.2	25	23.7 25.8	24.1 25.7	24.4 25.7	24.9 26	24.8 24.9	24.6 24.9	25 25.1	25.2 24.9
131	644.2	25.2	24.3 26.3	24.4 26.3	25 26.3	25.5 26.5	25.4 25.5	25.4 25.4	25.5 25.7	25.6 25.9
132	646.6	24.6	23.7 25.8	24 25.7	24.4 25.6	25 26	24.8 25	24.7 25	24.9 25	25.2 24.9
133	644	25	23.8 25.8	24.1 25.9	24.4 25.7	25 26.1	24.8 25	24.9 25.2	25 25.2	25.3 25
134	639.6	25	23.8 26.3	24.2 26.3	24.3 25.2	25.4 26.6	25.3 25.5	25.2 25.4	25.4 25.5	25.6 25.3
135	637.2	25.3	24.2 26.3	24.4 26.3	24.8 26.3	25.4 26.6	25.4 25.6	25.3 25.6	25.5 25.2	25.6 25.3
136	641.2	25.4	24.3 26.1	24.4 26.3	24.9 26.1	25.4 26.4	25.3 25.4	25.5 25.6	25.6 25.5	25.6 25.2
137	642.2	25.8	24.2 26.2	24.5 26.2	24.9 26.1	25.6 26.5	25.4 25.5	25.4 25.4	25.3 25.6	25.6 25.3
138	637.3	25.4	24 26.1	24.3 26	24.7 26	25.3 26.3	25.2 25.2	25.1 25.1	25.1 25.2	25.5 25
139	635	25.1	24 25.9	24.4 26	24.7 26	25.3 26.3	25.1 25.3	25 25.4	25.3 25.3	24.5 25.1
140	635	23.9	22.6 24.5	23 24.6	23.3 24.6	23.9 24.9	23.5 23.8	23.6 23.9	23.3 23.9	24.1 23.8
141	635.8		21.7 24.7	22.1 25	22.3 24.8	22.9 24.7	22.7 22.9	22.6 22.6	22.9 23	23.4 22.7
142	644.2	25.1	22.8 25.8	23.1 26.2	23.6 26	24.3 26	23.9 24	24.1 24.2	24.1 24.2	24.5 24
143	645	23	23.4 25.5	23.8 25.4	24.1 25.3	24.5 25.7	23.4 24.6	24.5 24.4	24.4 24.6	24.7 24.4
144	641	24.8	22.1 24.5	22.3 24.5	22.8 24.6	23.2 24.9	23.2 23.4	23.3 23.5	23.5 23.4	23.6 23.3
145	640.2	24.2	22.2 24.8	22.5 24.8	23 25	25.5 25.2	23.3 23.6	23.5 23.6	23.6 23.6	23.8 23.5
146	642.9	24.9	22.2 24.6	22.5 24.7	22.9 24.7	23.4 25.6	23.3 23.5	23.4 26.6	26.6 23.5	23.8 23.4
147	647	22.8	22.1 24.1	22.2 24.1	22.5 24.3	23 24.6	22.8 23.1	23.1 23.1	23.1 23.1	23.3 23
148	642	24.2	23 25.2	23.4 25.3	23.5 25.4	24.1 25.7	24.3 24.4	24.5 24.4	25 24.4	24.8 24.2
149	637.2	24.5	23.5 25.8	23.8 25.8	24 26	24.5 26.2	24.6 24.9	24.8 24.9	24.8 24.9	25.1 24.7
150	636.2	24.8	23.5 25.9	23.8 26.1	24.1 26.2	24.2 26.4	24.6 24.8	25 24.8	24.8 24.8	25.1 24.6
151	635.4	23.6	22.5 24.6	22.8 24.7	23.1 24.3	23.6 25.1	23.4 23.5	23.5 23.3	23.5 23.5	24.8 23.4

Table C-3. Continued.

Day	Atm P	RT	M 1 9	2 10	3 11	4 12	5 13	6 14	7 15	8 16
152	647	23.4	22.5 24.6	22.7 24.7	23.1 24.9	23.5 25.1	23.4 23.5	23.5 23.3	23.6 23.5	23.9 23.4
153	649.5	23.3	22.3 24.4	22.5 25.6	22.7 24.7	23.5 24.8	23.1 23.3	23.4 23.1	23.3 23.1	23.6 23.2
154	647	24.2	22.5 25	23.0 25.2	23.3 25.2	23.8 25.4	23.7 24	24 23.8	24 24	24.2 23.9
155	640.3	25	23.5 25.6	23.7 26.2	24.3 25.2	24.6 26.5	24.2 24.9	25 24.5	24.6 24.8	25 24.7
156	636.5	23.8	25.8 27.2	25.5 25.8	25.5 28.1	26.5 28.5	26 27	25.2 26.6	26.3 26.4	26.4 26.2
157	639.5	24	25.4 27.3	25.3 27.4	26.1 28.4	26.8 28.4	26.2 26.2	26.4 26.6	26.5 26.8	26.8 26.8
158	646.5	25	26.3 28.1	26.5 28.7	26.9 29.2	27.6 29.2	26.9 27.5	27.2 27.4	27.3 27.4	27.6 27.5
159	641.5	28.1	26.6 28.5	27.2 28.9	27.4 29.5	28 30	27.4 28	27.2 27.8	27.7 28	28 27.9
160	646.1	27.1	26 27.4	25.8 28	26.2 28.4	27.2 29.3	26.4 27	26.4 27.2	26.5 27.1	26.8 27
161	640.1	25.3	24.4 26.2	24.6 26.6	24.9 27.4	25.4 27.8	25.1 25.6	25.2 25.5	25.2 25.6	25.7 25.6
162	647.9	25.1	24.3 26	24.4 26.3	24.8 27.3	25.4 27.8	25 25	25.1 25.5	25.1 25.5	25.4 25.5
163	650.6	25.4	24.4 26.3	24.7 26.7	25.1 27.6	25.7 28.1	25.2 25.7	25.4 25.7	25.4 25.2	25.6 25.7
164	647.5	26	24.8 26.6	25.1 27.1	25.5 28	26.1 28.5	25.4 26.2	25.6 26.1	25.6 26	25.8 26
165	648.3	26.4	25 26.8	25.1 27.1	25.5 28	26.1 28.5	25.6 26.4	25.7 26.3	25.7 26.3	25.8 26.2
166	648.6	25.9	24.8 26.6	25 26.9	25.4 27.8	26 28.3	25.2 26.1	25.3 25.9	25.4 26.1	26.7 26.1
167	649.5	26.6	24.8 26.7	25.1 27	25.5 27.9	26 28.3	25.3 26	25.4 25.9	25.5 26	25.7 25.9
168	648.1	26.8	25 27	25.4 27.5	25.7 28.4	26.2 28.8	25.8 26.5	25.9 26.6	26 26.6	26.2 26.5
169	644.4	26	24.3 27	25.4 27.4	25.8 28.2	26.2 28.8	25.8 26.8	25.8 26.4	26 26.3	26.1 26.2
170	644.3	26.1	25.2 26.9	25.3 27.4	25.6 28.1	26.1 28.6	25.6 26.4	25.8 26.4	25.6 26.4	26 26.2
171	644.3	26.2	24.9 26.7	25.2 27.2	25.5 27.8	26 28.4	24.5 26	25.5 25.2	25.6 26.2	25.7 26.2
172	642.9	25.1	23.8 25.6	24.9 26	24.1 25.8	24.7 27.2	24.4 25.1	24.4 25.1	24.6 25.1	25.1 24.8
173	642.7	25	23.8 25.6	24 26.1	24.3 25.9	24.3 27.3	24.3 25.1	24.7 25.3	24.5 25.2	24.6 24.9
174	641.7	25.6	24.2 26.1	24.5 26.4	24.7 27.4	25.2 27.8	24.9 26.3	25 26.6	25.1 26.6	25.2 26.3
175	638.4	26.2	24.8 26.9	25 27.1	25.3 28	25.6 28.4	26 27	26 27.3	26.1 27.3	26.2 27

Table C-3. Continued.

Day	Atm P	RT	M 1 9	2 10	3 11	4 12	5 13	6 14	7 15	8 16
176	636.1	26.5	24.9	25.3	25.5	26	26.1	26.2	26.2	26.4
			27	27.3	28.1	28.6	27.2	27.4	27.4	27.1
177	638	24	23.3	23.6	23.9	24.2	24.3	24.4	24.3	24.5
			25.1	25.1	26.1	26.6	25.1	25.2	25.5	25.3
178	645.5	24	23.1	23.4	23.7	24.1	24.3	24.3	24.3	24.4
			24.9	25.2	25.1	26.5	25	25.2	25.5	25.2
179	647	24.2	23.1	23.3	23.7	24	23.9	24.3	24.3	24.4
			25	25.2	25.9	26.6	25	25.4	25.5	25.2
180	645.7	24.8	23.4	23.7	24	24.4	24.4	24.6	24.6	24.6
			25.4	25.7	26.3	26.9	25.5	25.5	25.9	25.7
181	645.6	25	23.6	23.9	24.3	24.6	24.3	24.6	24.6	24.9
			25.8	25.9	26.6	27.1	25.6	26	26.1	25.9
182	639.1	26.3	24.2	24.5	24.2	25.1	25.2	25.6	25.5	25.6
			26.2	26.4	27.1	27.6	26.2	26.4	26.6	26.5
183	636.7	25.9	24.5	24.8	25.1	25.4	25.5	25.8	25.8	25.9
			26.5	26.8	27.4	28	25.5	26.6	27	26.7
184	638.6	24.9	24.1	24.4	24.4	25	24.8	25.1	25.1	25.2
			25.6	26	26.1	27.4	25.8	26.2	26.3	26.1
185	640.3	25	23.9	24.2	24.4	24.8	24.6	25	25.1	25.1
			25.9	26	26.5	27.4	25.7	26.1	26.2	26
186	644.8	24	23.3	23.6	23.8	24.2	24.2	24.3	24.4	24.4
			25	25.2	26	26.7	25.2	25.3	25.6	25.4
187	649.3	25	23.7	23.9	24.2	24.5	24.6	24.8	25	25
			25.6	25.7	26.4	27.2	25.6	26	26	25.8

Table C-4. Nutrient/gas accumulation values.

Microcosm 1										
Day	P	Fe	Hg	N	C	V _{NET}	N ₂	O ₂	CO ₂	CH ₄
13	-0.290	0.5661	0.0056	32.23	260.0	-9.64	28.83	-59.00	52.66	1.826
27	2.185	0.8577	0.0119	46.22	377.8	-26.8	32.90	-205.	116.5	2.635
42	5.599	4.743	0.0187	15.17	580.3	-8.26	7.159	-326.	340.0	44.56
56	8.621	6.229	0.0250	41.17	735.4	16.24	26.51	-400.	396.6	31.43
70	10.76	6.513	0.0313	50.64	878.9	32.68	30.92	-402.0	427.8	39.44
84	12.41	7.552	0.0376	69.65	1001.	48.65	39.93	-552.	467.3	44.02
98	13.97	8.405	0.0439	77.76	1126.	56.90	47.70	-678.3	545.8	57.11
111	14.90	8.982	0.0498	96.61	1190.	75.07	65.92	-773.	630.2	64.21
126	16.57	9.912	0.0565	109.7	1303.	76.42	76.62	-881.	706.0	64.58
140	17.16	10.73	0.0628	121.8	1357.	76.70	82.33	-979.	779.0	63.48
154	17.82	10.61	0.0691	120.5	1476.	73.72	77.77	-1077.	849.6	61.42
168	19.46	12.36	0.0754	126.3	1538.	83.97	83.89	-1176.	950.9	63.30
187	19.99	13.31	0.0839	135.7	1609.	87.92	87.76	-1308.	1047.	65.55

Microcosm 3										
Day	P	Fe	Hg	N	C	V _{NET}	N ₂	O ₂	CO ₂	CH ₄
13	-0.36	0.1274	-0.495	39.27	262.3	-16.2	29.35	-66.30	63.24	2.02
27	2.500	2.172	-1.05	74.68	408.1	-21.2	67.96	-225.4	163.5	4.05
42	5.664	4.226	-1.65	97.11	556.1	9.210	85.45	-346.9	319.4	36.37
56	11.40	5.011	-2.23	119.1	925.3	52.94	96.60	-404.5	368.6	46.10
70	12.41	5.460	-2.78	113.5	986.5	55.72	91.00	-507.3	458.6	58.29
84	13.49	5.960	-3.34	100.0	1135.	54.76	72.99	-573.4	523.4	71.42
98	15.13	7.150	-3.69	76.50	1265.	42.79	48.96	-694.4	644.3	86.65
111	16.24	7.700	-4.24	80.08	1345.	51.44	50.87	-788.0	744.1	89.38
126	17.22	8.790	-4.84	62.36	1515.	44.95	29.12	-898.1	861.0	95.35
140	18.67	8.390	-5.33	46.40	1590.	42.27	9.59	-995.9	952.5	99.59
154	19.84	8.720	-5.81	14.77	1655.	30.88	-25.6	-1095.	1039.	100.2
168	20.83	9.410	-6.38	2374	1783.	44.43	-42.7	-1190.	1122.	109.0
187	21.88	9.820	-7.15	-26.3	1860.	43.35	-71.7	-1323.	1244.	117.0

Microcosm 2										
Day	P	Fe	Hg	N	C	V _{NET}	N ₂	O ₂	CO ₂	CH ₄
13	-0.135	0.5211	0.0056	11.58	287.9	-26.3	8.241	-58.00	62.25	1.65
27	4.644	5.144	0.0119	78.26	432.0	10.77	78.07	-190.1	185.6	5.68
42	6.858	5.678	0.0187	126.7	698.1	70.91	121.5	-303.8	427.0	48.93
56	10.01	7.57	0.0251	168.6	906.3	120.9	162.1	-373.2	493.2	66.32
70	11.16	7.52	0.0313	187.9	1068.	169.9	186.8	-435.9	502.7	90.13
84	12.58	8.50	0.0377	210.7	1246.	197.0	207.6	-511.8	637.0	106.6
98	14.05	10.49	0.044	217.0	1437.	221.2	215.0	-622.8	769.5	144.1
111	15.00	11.15	0.0494	238.9	1534.	254.3	241.9	-721.6	884.2	171.7
126	16.27	12.34	0.0566	251.8	1699.	273.1	253.4	-825.7	1037.	195.7
140	17.79	13.44	0.0629	263.8	1825.	287.3	264.7	-921.1	1140.	217.2
154	20.00	14.03	0.0691	271.0	1903.	284.4	271.3	-1017.	1230.	224.4
168	20.96	14.65	0.0755	282.0	2007.	308.4	283.6	-1112.	1351.	244.4
187	21.97	16.00	0.1610	293.9	2119.	318.8	297.6	-1241.	1498.	264.8

Microcosm 4										
Day	P	Fe	Hg	N	C	V _{NET}	N ₂	O ₂	CO ₂	CH ₄
13	-0.236	0.2400	-0.472	33.23	259.5	-7.09	27.49	-50.56	62.23	1.024
27	1.415	1.068	-1.00	16.06	411.3	-33.4	13.47	-190.5	153.6	3.24
42	3.784	2.030	-1.49	-35.0	582.1	-54.4	-46.3	-307.9	286.0	25.77
56	8.393	5.800	-2.14	-65.3	753.9	-43.7	-64.5	-376.0	312.6	19.65
70	10.52	6.355	-2.70	-38.0	913.5	7.205	-40.7	-435.5	382.2	36.14
84	12.48	7.860	-3.09	26.1	1078.	34.86	-30.2	-518.1	433.8	55.40
98	14.24	8.980	-3.63	-27.2	1210.	53.17	-29.7	-615.6	523.0	79.0
111	15.36	9.330	-4.12	-4.06	1315.	93.07	-5.13	-713.7	637.3	109.2
126	16.35	9.780	-4.61	13.72	1516.	121.0	12.34	-818.5	765.0	136.4
140	18.23	10.83	-5.11	25.89	1626.	142.1	23.45	-913.1	866.7	160.7
154	27.00	21.09	-5.65	41.19	1728.	167.2	35.22	-986.3	1555.	168.4
168	28.60	25.68	-6.17	43.80	2093.	194.0	37.05	-1081.	1619.	179.5
187	31.68	28.96	-6.89	5.800	2232.	180.0	1.280	-1210.	1743.	190.

Table C-4. Continued.

Microcosm 5										
Day	P	Fe	Hg	N	C	V _{NET}	N ₂	O ₂	CO ₂	CH ₄
13	-5.47	.3186	.0256	-5.88	278.5	-1.95	-11.5	13.210	-3.78	2.04
27	-7.75	.4225	.0119	-2.17	337.9	109.6	-4.91	136.34	-9.45	4.62
42	-1.62	.2209	.0187	19.70	351.8	213.9	17.76	235.80	-15.2	10.21
56	-2.32	.4707	.0250	-47.8	368.6	224.3	-46.6	294.04	-20.7	16.95
70	-3.13	.1548	.0313	-28.5	385.6	235.3	-25.8	259.90	-7.73	17.63
84	-3.80	1.075	.0377	-22.7	388.7	281.7	-20.6	291.60	-2.41	17.27
98	-4.17	2.580	.0440	-64.3	452.9	335.4	-61.1	387.10	-2.56	18.88
111	-4.67	3.223	.0499	-87.4	452.5	357.9	-82.7	422.20	-22.10	18.57
126	-5.26	3.860	.0566	-123.	463.1	394.4	-116.	488.80	-9348	19.4
140	-5.63	4.425	.0630	-114.	466.9	452.8	-110.	535.30	4.140	22.57
154	-5.92	5.690	.0693	-130.	470.1	505.8	-122.	615.50	7.210	21.53
168	-6.17	6.220	.0785	-59.0	483.0	581.0	-48.0	584.30	15.42	23.89
187	-7.22	6.530	.0844	-40.1	471.6	601.9	-26.1	674.40	16.78	24.56

Microcosm 7										
Day	P	Fe	Hg	N	C	V _{NET}	N ₂	O ₂	CO ₂	CH ₄
13	-4.39	.3636	-5.06	34.46	267.0	26.92	26.90	10.750	-3.68	1.523
27	-1.19	.1324	-1.00	64.46	434.4	198.4	56.26	198.00	-9.22	5.15
42	-1.74	.3529	-1.68	177.5	473.4	377.5	169.9	296.50	-14.8	8.977
56	-0.00	.6558	-2.11	169.8	608.9	404.0	155.9	303.00	-20.2	12.16
70	.1433	.5242	-2.69	198.1	667.3	491.5	181.3	358.40	-7.94	17.02
84	.0434	.9532	-3.01	214.8	692.3	602.0	195.6	493.50	2.740	18.96
98	-3.93	2.483	-3.65	200.6	739.2	721.8	179.6	669.30	-2.62	23.84
111	-1.92	2.653	-4.17	195.6	742.2	802.9	175.3	784.50	-1064	24.51
126	-1.64	3.438	-4.81	210.8	745.0	885.8	189.9	878.10	2.990	24.05
140	-2.12	3.524	-5.36	221.3	1004.	957.0	195.7	959.10	6.010	26.61
154	-2.70	4.372	-5.87	215.5	955.8	1047.	194.0	1090.0	9.048	26.64
168	-2.89	5.563	-6.41	222.0	992.1	1106.	203.7	1101.0	13.88	27.36
187	-3.65	5.844	7.24	219.3	972.8	1230.	204.1	1234.0	14.85	30.24

Microcosm 6										
Day	P	Fe	Hg	N	C	V _{NET}	N ₂	O ₂	CO ₂	CH ₄
13	-5.06	.5099	.0056	22.54	267.0	37.47	22.30	33.230	-3.67	1.684
27	-1.43	.2345	.0119	2.810	387.6	36.67	5.990	-18.06	-9.33	3.548
42	-2.96	1.147	.0187	90.14	416.8	189.7	97.90	48.230	-15.1	7.67
56	2.161	6.500	.0250	32.69	598.5	200.3	36.76	89.030	-20.5	9.02
70	1.250	5.232	.0313	19.45	605.3	237.4	26.06	113.90	-9.04	12.82
84	1.494	7.040	.0376	4.122	600.7	244.8	10.06	96.310	-4.28	13.77
98	3.721	9.873	.0439	10.69	882.1	244.5	10.69	10.48	2.880	13.79
111	4.665	10.23	.0498	18.72	954.0	256.3	24.78	-63.60	28.57	18.90
126	6.163	12.65	.0565	-84.8	1177.	270.0	-82.4	-17.01	27.15	48.02
140	9.259	15.27	.0628	-122.	1326.	275.6	-130.	31.900	33.25	36.42
154	10.58	20.07	.0691	-135.	1452.	287.7	-137.	7.1400	36.79	35.87
168	12.84	22.39	.0755	-95.6	1720.	295.2	-101.	-114.4	65.18	38.69
187	13.17	24.94	.0840	-148.	1903.	316.4	-150.	-97.70	68.30	42.24

Microcosm 8										
Day	P	Fe	Hg	N	C	V _{NET}	N ₂	O ₂	CO ₂	CH ₄
13	-4.45	.4649	-4.450	22.51	256.7	73.07	20.80	141.90	-3.59	3.61
27	-2.35	.8807	-0.954	33.79	326.7	180.3	32.68	217.70	-9.02	3.983
42	1.361	2.550	-1.40	126.8	390.7	405.2	130.4	428.50	-14.5	4.526
56	6.441	9.662	-2.09	144.5	558.7	507.7	120.0	593.40	-19.7	4.172
70	4.900	8.332	-2.72	190.4	580.9	617.7	175.9	682.10	-7.05	6.765
84	16.19	10.27	-3.20	191.4	602.0	709.6	181.4	806.60	-1.70	7.214
98	18.55	16.60	-3.76	190.2	744.4	788.1	180.9	967.30	5.890	6.610
111	10.42	21.43	-4.24	215.1	823.3	872.4	200.6	998.20	7.596	6.637
126	10.20	22.97	-4.67	223.3	837.0	962.1	212.5	1104.0	8.576	6.668
140	19.23	24.70	-5.07	239.8	851.8	1066.	229.8	1227.0	11.94	6.700
154	19.09	26.14	-5.36	243.5	897.9	1151.	240.4	1338.0	17.12	6.730
168	19.88	27.57	-5.57	244.3	931.9	1211.	245.4	1379.0	18.58	6.750
187	18.76	28.50	-6.29	236.9	919.6	1319.	242.9	1526.0	20.28	6.790

Table C-4. Continued.

Microcosm 9										
Day	P	Fe	Hg	N	C	V _{NET}	N ₂	O ₂	CO ₂	CH ₄
13	-0.675	.2400	.0056	13.42	228.2	39.57	8.610	45.800	-3.79	3.001
27	-1.37	.1510	.0119	70.18	219.7	312.5	57.57	370.60	-9.46	13.64
42	1.012	3.264	.0187	147.5	450.2	501.1	124.5	520.10	-15.4	31.63
56	5.213	7.939	.0250	192.8	597.5	693.7	167.2	704.60	-20.8	54.24
70	6.070	7.965	.0312	295.7	731.7	873.1	261.3	831.50	-0.74	61.49
84	8.034	9.356	.0375	280.3	787.8	905.3	238.1	890.60	-3.95	56.93
98	14.64	16.28	.0438	266.4	992.1	1016.	216.1	1000.0	-2.19	63.92
111	20.53	25.39	.0497	287.4	1182.	1117.	227.1	1176.0	-2.02	64.85
126	24.05	29.91	.0565	308.3	1357.	1173.	240.0	1180.0	-1.43	65.36
140	28.17	33.01	.0628	309.5	1310.	1290.	228.8	1336.0	2.116	67.35
154	30.64	35.79	.0691	311.9	1438.	1409.	228.2	1496.0	4.554	70.74
168	30.37	36.30	.0755	324.3	1455.	1536.	241.7	1544.0	6.567	71.95
187	30.73	37.83	.0841	312.8	1495.	1644.	225.0	1817.0	10.16	72.60

Microcosm 11										
Day	P	Fe	Hg	N	C	V _{NET}	N ₂	O ₂	CO ₂	CH ₄
13	-0.616	.3064	-0.517	-35.2	272.5	-4.43	-38.0	44.	-3.72	1.640
27	-1.46	.3724	-1.10	59.51	264.8	329.9	56.22	432.80	-9.23	16.05
42	-2.14	.1684	-1.72	98.55	288.9	460.4	86.26	532.90	-14.9	20.80
56	-1.25	.3907	-2.30	91.11	306.0	546.1	83.01	651.00	-20.1	27.40
70	-2.39	.1529	-2.86	123.1	339.3	599.1	108.7	680.60	-8.21	24.04
84	-2.51	1.133	-3.45	140.0	346.6	682.2	121.8	771.30	-3.14	27.16
98	-2.70	3.280	-3.94	126.8	420.8	752.4	105.7	873.60	-1.29	28.48
111	-3.64	3.350	-4.50	128.4	411.8	846.7	108.4	982.10	.9729	34.06
126	-4.57	3.040	-5.09	128.8	383.5	943.0	110.2	1104.0	3.650	33.48
140	-5.16	3.180	-5.64	132.6	371.4	1032.	110.3	1224.0	6.440	37.71
154	-6.03	3.303	-6.23	131.4	348.8	1140.	110.9	1370.0	9.190	37.20
168	-6.62	3.149	-6.78	141.8	306.1	1240.	123.8	1478.0	11.00	40.00
187	-8.78	3.165	-7.60	149.5	268.3	1365.	134.1	1643.0	14.71	40.03

Microcosm 10										
Day	P	Fe	Hg	N	C	V _{NET}	N ₂	O ₂	CO ₂	CH ₄
13	-0.652	.5324	.0056	13.21	250.0	34.91	11.78	37.430	-3.76	1.325
27	-1.55	.1382	.0119	58.95	231.2	339.9	59.97	408.50	-9.38	14.35
42	-1.94	.4460	.0187	100.5	264.7	469.0	100.6	530.20	-15.1	19.01
56	-1.34	.6282	.0250	90.80	291.6	558.1	98.39	659.30	-20.5	18.61
70	-2.40	.3716	.0313	135.3	320.5	652.6	146.1	722.00	-8.64	19.34
84	-3.34	.2870	.0375	147.8	315.4	770.8	162.2	856.10	-3.64	23.21
98	-4.02	.5128	.0439	139.0	307.5	873.0	154.1	995.10	-1.82	26.41
111	-4.56	.5470	.0497	150.7	291.9	990.1	170.9	1136.0	.3228	25.67
126	-5.71	.3697	.0565	154.0	283.9	1089.	179.2	1251.0	2.900	27.66
140	-6.39	.4390	.0628	160.8	267.6	1186.	187.0	1371.6	5.640	28.10
154	-6.98	.7590	.0691	159.4	245.5	1286.	193.2	1503.0	10.28	29.01
168	-7.46	.4420	.0754	164.4	216.7	1385.	204.8	1617.0	11.99	29.34
187	-8.86	.0145	.0839	181.4	179.9	1508.	226.3	1756.1	15.79	31.86

Microcosm 12										
Day	P	Fe	Hg	N	C	V _{NET}	N ₂	O ₂	CO ₂	CH ₄
13	-0.495	.4424	-0.518	21.15	216.7	72.44	19.51	92.860	-3.66	2.220
27	-1.29	.2984	-1.09	71.75	219.5	347.9	72.65	430.20	-9.06	28.86
42	-2.20	-0.190	-1.72	115.5	222.3	494.3	122.2	567.20	-14.6	31.50
56	-2.52	-0.602	-2.32	117.7	225.5	617.2	129.8	737.80	-19.8	33.40
70	-3.70	-1.01	-2.88	166.4	229.5	707.8	180.9	797.60	-7.95	32.91
84	-4.72	-1.23	-3.52	174.5	235.2	806.5	189.6	920.50	-2.84	34.60
98	-5.71	-1.35	-4.00	182.0	218.8	934.6	197.9	1083.0	-2.69	38.75
111	-6.52	-1.78	-4.63	195.7	198.1	1051.	217.2	1220.0	-0.052	39.63
126	-7.51	-1.97	-5.22	218.3	267.0	1195.	246.3	1388.0	2.700	40.10
140	-8.23	-2.18	-5.79	234.6	247.5	1300.	260.8	1517.0	5.554	41.52
154	-8.25	-2.25	-6.09	248.3	290.1	1422.	276.5	1680.0	8.380	40.75
168	-0.00	-2.72	-6.68	273.3	252.7	1558.	308.5	1812.0	10.21	44.02
187	-10.5	-3.16	-7.52	290.4	215.4	1688.	331.0	1964.0	13.74	45.78

Table C-4. Continued.

Microcosm 13										
Day	P	Fe	Hg	N	C	V _{NET}	N ₂	O ₂	CO ₂	CH ₄
13	-6.68	.4199	.0056	-3.86	283.5	-5.38	-42.9	55.700	-5.37	1.260
27	-1.36	.1022	.0119	-4.52	306.8	90.68	-9.49	97.830	-10.8	7.970
42	-2.19	.1441	.0187	34.88	367.9	296.4	34.70	312.90	-16.0	22.00
56	-2.59	.4580	.0250	28.89	375.5	365.8	31.84	412.80	-22.0	19.20
70	-3.07	.6332	.0313	32.74	406.6	427.0	38.93	484.60	-9.50	19.66
84	-3.58	.8670	.0376	43.57	407.6	515.0	42.22	600.00	-4.11	20.63
98	-4.22	2.540	.0439	40.12	418.2	617.5	33.15	749.50	-6.26	20.03
111	-4.56	3.790	.0498	44.76	433.9	676.7	40.63	779.60	-3.97	20.05
126	-4.61	4.230	.0565	44.79	450.7	776.9	41.43	891.70	-1.74	20.08
140	-5.46	4.240	.0628	55.73	444.1	874.2	48.16	1007.0	.8598	20.11
154	-6.15	4.590	.0691	49.12	448.5	952.7	45.85	1115.0	3.710	20.14
168	-6.60	4.660	.0754	58.43	415.1	1049.	48.70	1211.0	5.700	21.13
187	-7.84	4.810	.0840	83.99	394.1	1197.	94.21	1382.0	7.150	21.97

Microcosm 15										
Day	P	Fe	Hg	N	C	V _{NET}	N ₂	O ₂	CO ₂	CH ₄
13	-5.76	.4311	.0066	16.07	261.1	22.54	15.09	14.240	-3.69	1.004
27	-0.969	.2894	-1.07	15.05	307.4	120.4	12.33	138.40	-9.17	1.622
42	-1.67	.3596	-1.68	81.74	358.7	353.3	81.54	396.70	-14.7	2.450
56	-2.00	.6327	-2.25	94.01	396.1	467.7	94.17	544.80	-20.0	3.650
70	-2.96	.1143	-2.81	126.6	422.4	542.3	129.3	608.00	-7.11	3.938
84	-3.26	1.170	-3.45	125.8	445.1	599.9	125.3	685.90	-1.97	3.404
98	-3.62	3.470	-4.02	120.2	467.6	696.0	119.8	820.40	-3.82	3.434
111	-4.37	3.670	-4.54	128.6	495.6	763.3	130.3	872.40	-1.11	3.460
126	-5.17	3.608	-5.18	137.5	488.4	897.5	141.0	1035.0	1.460	3.492
140	-5.91	3.933	-5.76	143.6	515.2	989.7	147.6	1152.0	4.285	3.521
154	-6.91	4.400	-6.25	140.1	530.3	1076.	147.8	1279.0	7.340	3.550
168	-7.60	4.937	-6.76	156.2	554.0	1179.	166.7	1387.0	9.581	3.580
187	-8.87	5.689	-7.53	165.5	558.5	1314.	181.3	1559.0	11.04	3.620

Microcosm 14										
Day	P	Fe	Hg	N	C	V _{NET}	N ₂	O ₂	CO ₂	CH ₄
13	-5.540	.4311	.0056	54.82	227.4	99.00	56.04	91.140	-3.70	1.080
27	-1.19	.4687	.0120	65.57	229.2	249.8	72.74	270.90	-9.33	1.770
42	-2.22	.1501	.0187	108.3	240.8	437.0	122.8	477.30	-15.0	2.530
56	-2.74	.2979	.0250	138.9	241.6	578.8	157.3	632.90	-20.4	5.610
70	-3.47	.2822	.0313	196.9	274.1	702.1	220.7	707.60	-7.52	18.27
84	-3.37	1.398	.0377	197.4	281.4	743.1	221.3	744.20	-3.03	13.01
98	-3.59	3.740	.0440	191.7	322.2	825.0	214.0	839.90	-1.29	14.70
111	-3.82	4.590	.0498	208.3	339.4	870.5	235.5	829.70	.3530	13.25
126	-4.42	5.272	.0566	208.1	333.5	976.6	240.5	935.20	2.590	15.43
140	-4.80	5.880	.0629	202.7	354.9	1033.	237.2	981.20	5.090	19.23
154	-5.46	6.447	.0691	132.4	392.7	1038.	174.0	1044.0	7.720	18.10
168	-5.92	6.770	.0754	95.20	361.8	1048.	142.1	1055.0	11.33	19.81
187	-7.19	6.929	.0840	18.67	352.2	1071.	73.99	1128.0	12.35	25.48

Microcosm 16										
Day	P	Fe	Hg	N	C	V _{NET}	N ₂	O ₂	CO ₂	CH ₄
13	-3.04	.5661	-5.06	35.45	227.4	58.33	35.44	54.290	-3.64	1.040
27	-1.05	.3380	-1.07	33.73	243.8	165.6	37.81	169.70	-9.11	2.258
42	-1.84	.1247	-1.68	119.3	262.0	345.4	129.4	302.80	-14.6	3.960
56	-1.39	-.242	-2.28	127.7	275.7	437.7	143.5	401.80	-19.8	5.696
70	-2.38	-1.04	-2.83	141.0	307.9	495.6	162.3	446.90	-6.99	8.744
84	-3.35	-.576	-3.40	153.2	301.1	578.4	174.1	541.50	-1.67	8.690
98	-4.11	-.580	-3.98	139.5	299.9	674.0	162.5	709.00	4.414	9.876
111	-4.72	-.653	-4.50	142.3	328.9	746.0	170.9	759.00	5.772	14.24
126	-5.72	-.841	5.13	148.2	306.8	868.3	181.2	917.80	8.610	13.39
140	-6.68	-1.08	-5.72	160.5	291.4	965.3	195.3	1039.0	11.61	12.60
154	-7.73	-1.32	-6.24	161.4	298.5	1061.	203.9	1166.0	14.85	13.16
168	-8.49	-1.76	-6.81	173.0	304.0	1163.	222.6	1273.0	17.20	16.98
187	-10.0	-2.12	-7.48	193.2	309.3	1314.	250.4	1457.0	18.82	17.29

Table C-5. Genera identified in wall scrapings at microcosms obtained at the end of the experimental run (day 183).

	Occurrence in Microcosms (Values in Estimated %)													
	1-4	5	6	7	8	9	10	11	12	13	14	15	16	
Sulfur Bacteria														
Thiobodaceae	10													
Achromatium	20													
Fungi														
Actinoplanes	5													
Protozoa														
Macromonas														
Trachelomonas								5						
Blue Green Algae														
Microcystis	60	75	25	50	97	50	40	35	35	30	90	95	75	
Oscillatoria				40	1	35	15	25	60	30	5	2	5	
Anabaena			75				25	30					15	
Green Algae														
Chlorella		20					5		5	30	5		5	
Chlamydomonas		5		5			15	15		10		3		
Ankistrodesmus						15								
Scenedesmus														
Vorticella														
Oedogonium				5										
Diatoms (not classified)			5		1									

Appendix D

Mercury Results

Table D-1. Total water phase mercury concentrations ($\mu\text{g/l}$).

Date	Microcosm								
	3	4	7	8	8cent.	11	12	15	16
23 Jan.	3.7	2.1	15.5	3.6	-	2.9	3.1	5.2	3.0
21 Feb.	5.6	17.0	22.0	*	-	2.6	*	*	3.8
8 Mar.	20.3	8.9	2.3	5.4	-	4.9	3.0	4.2	4.1
2 Apr.	6.0	13.0	3.2	16.8	-	5.3	4.3	2.9	6.7
9 Apr.	12.0	15.8	3.5	9.0	-	6.2	5.7	3.1	4.1
16 Apr.	11.0	11.3	5.7	18.0	-	6.2	5.0	4.4	3.3
24 Apr.	15.2	9.0	10.0	30.5	10.8	4.5	9.1	7.8	6.0
1 May	12.1	7.9	10.5	25.7	-	4.4	23.3	9.5	7.6
8 May	8.5	5.8	6.2	12.7	1.6	2.2	10.3	6.9	4.3
14 May	5.8	8.8	7.5	31.6	3.0	5.9	6.1	9.8	5.4
21 May	9.8	5.9	7.9	11.1	5.1	4.9	2.8	8.9	4.4
28 May	15.5	13.2	3.3	6.3	4.9	4.0	2.4	5.9	2.3
8 Jun.	5.1	7.7	2.0	7.9	-	2.3	1.4	5.5	10.5

*Indicates less than 1.0 $\mu\text{g Hg/l}$.

-Indicates no analysis performed.

8cent. means the supernatant of 8 centrifuged.

Samples were centrifuged @ 20,000 RPM for 10 minutes.

Table D-2. Total suspended solids (mg/l).

Date	Microcosm								
	3	4	7	8	11	12	15	16	
25 Jan.	3.3	3.8	14.5	158.7	12.9	3.5	15.3	5.9	
8 Feb.	2.4	2.8	15.5	13.0	11.1	0.7	6.4	1.9	
22 Feb.	1.4	2.3	23.7	40.0	21.9	1.7	25.6	2.8	
8 Mar.	1.6	2.6	20.3	120.0	31.3	4.0	24.5	4.2	
21 Mar.	1.6	1.4	15.1	54.3	15.0	4.7	12.9	8.2	
5 Apr.	1.2	0.9	16.5	37.3	9.6	2.6	5.8	2.3	
19 Apr.	1.8	3.7	15.3	65.3	6.8	4.9	10.1	2.4	
3 May	1.0	0.7	12.0	35.0	6.9	11.1	10.9	0.9	
17 May	1.4	4.5	20.2	71.5	7.2	3.3	13.8	2.9	
7 Jun.	1.4	3.4	13.4	18.1	4.0	2.1	8.8	3.1	

Table D-3. Volatile suspended solids (mg/l).

Date	Microcosm							
	3	4	7	8	11	12	15	16
25 Jan.	2.3	2.1	9.2	26.7	3.8	2.8	3.7	2.3
8 Feb.	1.6	2.3	11.5	3.3	3.0	0.7	2.3	1.7
22 Feb.	1.4	2.3	7.0	14.0	4.0	0.8	2.8	2.0
8 Mar.	1.2	1.0	3.0	28.9	4.9	1.0	3.3	2.3
21 Mar.	1.6	1.4	3.7	17.9	3.3	1.6	2.6	2.8
5 Apr.	0.1	0.7	2.6	2.7	2.3	1.0	1.9	0.7
19 Apr.	1.0	1.7	3.8	11.3	2.6	1.6	3.1	2.3
3 May	1.0	0.7	3.3	6.8	2.6	6.6	3.3	0.3
17 May	0.3	2.9	3.8	12.4	2.2	2.2	3.3	1.7
7 Jun.	1.4	1.7	1.9	3.3	1.2	0.5	4.0	1.4

Table D-4. pH versus time.

Date	Microcosm							
	3	4	7	8	11	12	15	16
31 Jan.	6.8	6.5	8.6	8.7	8.9	9.1	8.8	9.2
16 Feb.	7.1	7.4	9.4	9.6	9.6	10.0	9.4	9.7
23 Feb.	6.6	6.6	9.4	9.3	9.4	9.8	9.3	9.7
2 Mar.	6.9	6.8	9.3	9.3	9.4	9.6	9.3	9.6
9 Mar.	6.9	6.8	9.3	9.2	9.4	9.6	9.3	9.5
20 Mar.	6.9	6.8	9.5	9.4	9.6	9.9	9.3	9.4
27 Mar.	6.8	6.8	9.5	9.5	9.7	10.0	9.6	9.6
6 Apr.	6.6	6.6	9.5	9.5	9.5	9.8	9.4	9.4
20 Apr.	6.6	6.7	9.2	9.2	9.3	9.5	9.5	9.8
4 May	6.5	3.3	9.2	9.3	9.6	9.9	9.5	9.9
18 May	6.6	6.5	9.0	8.9	9.3	9.6	9.0	9.4
25 May	6.6	6.9	9.1	9.1	9.4	9.6	9.5	9.9