

 Open access • Journal Article • DOI:10.1103/PHYSREVLETT.61.2099

## Observation of radially localized atomic electron wave packets. — [Source link](#)

A. ten Wolde, L. D. Noordam, Ad Lagendijk, Ad Lagendijk ...+1 more authors

**Institutions:** Fundamental Research on Matter Institute for Atomic and Molecular Physics, University of Amsterdam

**Published on:** 31 Oct 1988 - Physical Review Letters (American Physical Society)

**Topics:** Wave packet, Rydberg state, Pulse (physics), Ionization and Rydberg formula

Related papers:

- [Observation of spatially localized atomic electron wave packets.](#)
- [Coherence and decay of Rydberg wave Packets.](#)
- [Observation of the collapse and revival of a Rydberg electronic wave packet.](#)
- [Classical periodic motion of atomic-electron wave packets.](#)
- [Generation and detection of Rydberg wave packets by short laser pulses.](#)

Share this paper:    

View more about this paper here: <https://typeset.io/papers/observation-of-radially-localized-atomic-electron-wave-7oqokd4j0t>



## UvA-DARE (Digital Academic Repository)

### Observation of Radially Localized Atomic Electron Wave Packets

Wolde, A. ten; Noordam, L.D.; Lagendijk, A.; Linden van den Heuvell, H.B. van

**DOI**

[10.1103/PhysRevLett.61.2099](https://doi.org/10.1103/PhysRevLett.61.2099)

**Publication date**

1988

**Published in**

Physical Review Letters

[Link to publication](#)

**Citation for published version (APA):**

Wolde, A. T., Noordam, L. D., Lagendijk, A., & Linden van den Heuvell, H. B. V. (1988). Observation of Radially Localized Atomic Electron Wave Packets. *Physical Review Letters*, 61(18), 2099-2101. <https://doi.org/10.1103/PhysRevLett.61.2099>

**General rights**

It is not permitted to download or to forward/distribute the text or part of it without the consent of the author(s) and/or copyright holder(s), other than for strictly personal, individual use, unless the work is under an open content license (like Creative Commons).

**Disclaimer/Complaints regulations**

If you believe that digital publication of certain material infringes any of your rights or (privacy) interests, please let the Library know, stating your reasons. In case of a legitimate complaint, the Library will make the material inaccessible and/or remove it from the website. Please Ask the Library: <https://uba.uva.nl/en/contact>, or a letter to: Library of the University of Amsterdam, Secretariat, Singel 425, 1012 WP Amsterdam, The Netherlands. You will be contacted as soon as possible.

## Observation of Radially Localized Atomic Electron Wave Packets

A. ten Wolde,<sup>(1)</sup> L. D. Noordam,<sup>(1)</sup> A. Lagendijk,<sup>(1,2)</sup> and H. B. van Linden van den Heuvell<sup>(1)</sup>

<sup>(1)</sup>*Foundation for Fundamental Research on Matter (FOM)–Institute for Atomic and Molecular Physics, Kruislaan 407, 1098 SJ Amsterdam, The Netherlands*

<sup>(2)</sup>*Natuurkundig Laboratorium van de Universiteit van Amsterdam, Valckenierstraat 65, 1018 XE Amsterdam, The Netherlands*

(Received 11 July 1988)

We have observed a radially localized electron wave packet in a direct pump-probe experiment with 6-ps laser pulses. Use is made of the fact that both excitation and ionization take place predominantly close to the atomic core. A wave packet is created by coherently exciting Rydberg states of rubidium atoms around  $n=41$  with a pump pulse, and detected through ionization with a delayed probe pulse. The wave packet is observed to return to the core twice before the spreading becomes too large.

PACS numbers: 32.80.Rm, 31.50.+w

When an atomic electron is brought into a highly excited state with a short laser pulse, a radial wave packet can be formed. To this end the pulse duration must be shorter than the time scale on which the wave function of the excited state becomes stationary. This wave packet is a coherent superposition of Rydberg states, and describes a radially localized electron which oscillates between the classical turning points. It offers an interesting example of quantum beats. Various calculations concerning Rydberg wave packets have been presented in the last few years.<sup>1,2</sup> In a recent paper<sup>3</sup> we report evidence for the return of the radial electronic wave function to the core, in a single-pulse multiphoton ionization experiment. Localization in other than the radial coordinate is also possible; e.g., angular wave packets have been reported recently.<sup>4</sup> In this Letter we report the first observation, to our knowledge, of a radially localized wave packet.

The wave packet is created by coherent excitation of a rubidium atom to high-lying Rydberg states with a 6-ps laser pulse. An advantage of rubidium is that the atom is a quasi one-electron atom. Furthermore, the binding energy of the outermost electron is 4.18 eV, so that Rydberg states can be excited with two photons having a wavelength around 600 nm. This is convenient for the experiment because the dye rhodamine 6G can be used. Coherent excitation can take place if the frequency bandwidth of the exciting pulse is larger than the spacing between the eigenstates. If this pulse is transform limited a wave packet is formed, which starts to oscillate in the radial direction, roughly between the classical turning points. The period of the oscillation is given by the energy spacing between the excited Rydberg levels. In the limit for  $\Delta n \ll n$  the spacing becomes uniform, and the corresponding period is equal to the classical orbit time (in atomic units):

$$\tau_n = 2\pi n^3, \quad (1)$$

where  $n$  denotes the effective principal quantum number. With picosecond pulses, Rydberg states with  $n$  values

somewhere between 20 and 100 could be excited. The remaining variation in the spacing between the levels ( $3/n^4$  in a.u.) causes a spreading of the wave packet. The spreading per orbit depends on the number of excited  $n$  states and therefore on the bandwidth of the exciting pulse. In the case of  $N$  photon excitation, the combined bandwidth of the exciting photons should be considered, rather than the bandwidth of the pulse itself. For a Gaussian profile the initial width of the wave packet is a factor of  $\sqrt{N}$  shorter than the duration  $\tau_p$  of the exciting pulse. The number of excited levels, given by the ratio of the classical orbit time and the initial width, results in a broadening of the wave packet after one orbit of (in a.u.)

$$\Delta\tau_n = 6\pi n^2 \frac{\tau_n}{\tau_p/\sqrt{N}} = 12\pi^2 \sqrt{N} \frac{n^5}{\tau_p}. \quad (2)$$

For a given pulse duration  $\tau_p$  of the ionizing pulse, the time resolution in a pump-probe experiment is optimal if this broadening is equal to  $\tau_p$ : This determines an optimal value for  $n$  (see Ref. 5).

In the present experiment, a wave packet is created near the core of the atom through absorption of two photons. Because the two photons are linearly polarized, the wave function contains  $s$  and  $d$  character. It is to be expected that the  $d$  character is dominant. The presence of wave packet close to the core can be detected by the application of a probe pulse which is delayed with respect to the pump pulse. If the timing of the probe pulse coincides with a return of the wave packet, the atom can be ionized much more efficiently (see, e.g., Refs. 6 and 7). Measuring the ionization signal as a function of the time difference between the exciting pump and the ionizing probe pulse directly shows the returns of the wave packet.

A schematic drawing of the experimental setup is shown in Fig. 1. A mode-locked Ar<sup>+</sup> laser (0.6-W output, 80-MHz repetition rate, and 120-ps pulse duration) synchronously pumps a linear dye laser (wavelength 594 nm, 60-mW output). The pulses coming out of the dye

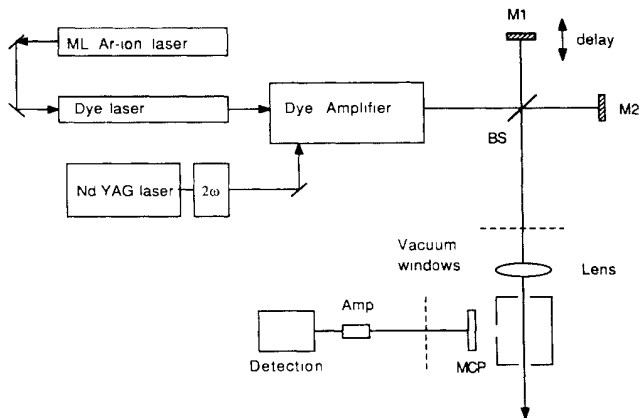

FIG. 1. Schematic drawing of the experimental setup.

laser have a duration of 5 ps. They are amplified in three stages in a dye amplifier by the second harmonic of a  $Q$ -switched Nd-doped yttrium-aluminum-garnet (200-mJ pulse energy, 20-Hz repetition rate). The energy of the amplified pulses is  $600 \mu\text{J}$ : Only 5% of this energy was needed for the experiment. The pulse duration has been measured with a scanning autocorrelator to be 6 ps. The measured field correlation time is about 4 ps, so that the amplified pulses are nearly transform limited. Each pulse is divided by a beam splitter. Both pulses are reflected by a mirror, and the beams are reunited with the same beam splitter. One of the mirrors is mounted on a translational stage in order to vary the time difference between the two pulses by changing the optical path length. The delay is tunable over a large range with a precision of  $1 \mu\text{m}$ , corresponding to about 7 fs. Since the two pulses are identical, a negative delay means that the roles of pump and probe pulses have been reversed. After the beam splitter the pulses are focused with a 16-cm lens in a vacuum vessel with a background pressure of  $2 \times 10^{-7}$  mbar. The laser beam crosses a diverging beam of atomic rubidium coming out of an orifice in a tube, which is connected to an oven. To minimize external electrical fields the excitation and ionization take place in a metal box. Our signal consists of the photoelectrons resulting from three-photon ionization: These electrons have an energy of 2 eV. Outside the box the electrons are decelerated by a grid at  $-0.1$  V. In this way electrons with energies of  $\approx 0$  eV, which are created after the pulse sequence by slow processes like collisions, are stopped. The remaining electrons are accelerated in the direction of a set of channel plates. The signal of the channel plates is amplified, and the electron peak in the resulting time-of-flight spectrum is averaged over 500 laser shots, integrated, and monitored with a digital scope with a personal computer. With this experimental setup, the three-photon ionization signal can be measured as a function of the time difference between the two pulses.

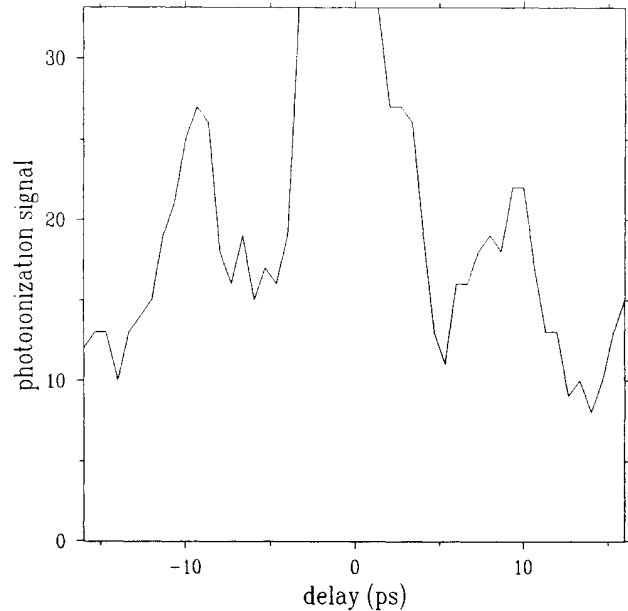

FIG. 2. The pump-probe photoionization signal as a function of the time difference between the two pulses. The numbers along the vertical axis are only for comparison with Fig. 3. For zero delay, the probe pulse directly ionizes the atoms excited by the pump pulse. At  $-9$  and  $9$  ps the return of the wave packet is clearly observed.

By varying the laser wavelength, different Rydberg states can be excited. Both the classical orbit time, determined by the spacing between the levels, and the dispersion of the electron wave packet, determined by the number of excited states, can be varied in this way. In the case of two-photon excitation with a pulse duration of 6 ps and a coherence time of 4 ps, the spreading after one orbit is equal to the effective pulse duration for  $n=40.7$  [see Eq. (2)]. In the experiment the central laser wavelength was 594.8 nm, corresponding to the  $42d$  state of rubidium ( $\delta_l=1.3$  for  $l=2$ ). The pulse energy was  $30 \mu\text{J}$ , and the beam diameter before focusing was 3 mm. The light intensity in the focus has been determined directly from the measured ac Stark shift for low- $n$  states:  $0.4 \times 10^{11} \text{ W/cm}^2$ . This value agrees with the upper limit based on the following calculation: A 3-mm beam diameter and a 16-cm lens lead to a diffraction-limited focal radius of  $40 \mu\text{m}$  and therefore to an estimated intensity of  $1.5 \times 10^{11} \text{ W/cm}^2$ .

The experimental results are given in Figs. 2 and 3. First, in Fig. 2 the ionization signal excluding direct ionization by the separate pulses is given. We see three peaks in the ionization yield, roughly at  $-9$ ,  $0$ , and  $9$  ps. These peaks correspond to a large amount of wave function near the core, ionized by the probe pulse. For zero delay, the wave packet has not left the core yet; the central peak is the result of direct ionization with photons from both pulses. For delays  $-9$  and  $9$  ps, the wave packet has returned to the core; the experimentally ob-

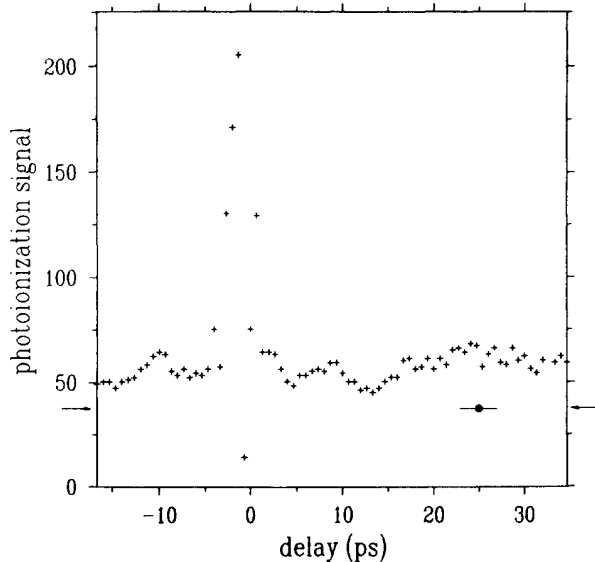

FIG. 3. The photoionization signal including direct photoionization by the pump and probe pulses separately. The sum of the measured contributions of the individual pulses has been given at 25-ps delay. The contributions are independent of the delay and lead to a constant level of ionization, as indicated by the two arrows. The large modulations around zero delay are the result of the coherent spike in the light intensity. Two returns of the wave packet are observed before the spreading becomes too large.

served classical orbit time is  $9.4 \pm 1$  ps. This agrees well with the theoretical value of 10.2 ps for the  $42d$  state, the dominant state in the wave packet.

Figure 3 gives the observed data including direct ionization by the individual pulses. The sum of the measured contributions of both pulses separately is given at 25-ps delay. Evidently, this signal is independent of the delay and gives rise to a constant level of ionization, as indicated by the two arrows. Around zero delay we see that the central peak has a high maximum but also an absolute minimum. This large modulation is the result of the so-called coherent spike in the light intensity. For small time differences, the pulses overlap spatially as well as temporally, giving rise to interference. In the case of perfect spatial overlap, this leads to an increase of the light intensity with a factor of 4 in the case of complete constructive interference, and a total quenching if the interference is fully destructive. The large modulation in the electron yield indicates that the spatial overlap of the two beams remains stable on a scale of less than  $\lambda/2$  during the signal averaging. At  $-9$  and  $9$  ps

we see the peaks resulting from the first return of the wave packet. At the minima for delays  $-14$ ,  $-6$ ,  $5$ , and  $14$  ps the wave packet has left the atomic core. After  $18$  ps, the wave packet returns to the core for the second time, but is not observed to leave the core anymore. This can be explained by the spreading of the wave packet: An initial width of  $4.3$  ps together with a broadening of  $2.8$  ps per orbit leads to a width of  $6$  ps after two orbits. In combination with the pulse duration of the probe pulse, which is also  $6$  ps, the total observed width is about  $8.4$  ps, which comes so close to the classical orbit time that the wave packet cannot be resolved anymore. Also, for longer delay times the ionization signal could be slowly modulated as a result of other beat phenomena.

In conclusion, a radially localized electronic wave packet is created with a picosecond dye-laser pulse. By means of photoionization we have observed the return of the wave packet to the core. As a result of the velocity difference of the various coherently excited Rydberg states, the wave packet spreads. After a second return to the core, the spreading of the wave packet is of the order of the classical orbit time: The returns cannot be resolved by the probe pulse anymore. The electronic wave packet may be used to study the behavior of atomic electrons on an ultrashort time scale.

We thank Dr. H. G. Muller for fruitful discussions. This work is part of the research program of the Stichting voor Fundamenteel Onderzoek der Materie (Foundation for the Fundamental Research on Matter) and was made possible by financial support of the Nederlandse Organisatie voor Wetenschappelijk Onderzoek (Netherlands Organization for the Advancement of Research).

<sup>1</sup>J. Parker and C. R. Stroud, Jr., Phys. Rev. Lett. **56**, 716 (1986).

<sup>2</sup>G. Alber, H. Ritsch, and P. Zoller, Phys. Rev. A **34**, 1058 (1986).

<sup>3</sup>L. D. Noordam, A. ten Wolde, H. G. Muller, A. Lagendijk, and H. B. van Linden van den Heuvell, to be published.

<sup>4</sup>J. A. Yeazell and C. R. Stroud, Jr., Phys. Rev. Lett. **60**, 1494 (1988).

<sup>5</sup>H. B. van Linden van den Heuvell, H. G. Muller, and A. ten Wolde, *Electronic and Atomic Collisions* (Elsevier, Amsterdam, 1988).

<sup>6</sup>A. Giusti-Suzor and P. Zoller, Phys. Rev. A **36**, 5178 (1987).

<sup>7</sup>H. B. van Linden van den Heuvell, H. G. Muller, J. W. J. Verschuur, and A. ten Wolde, J. Phys. B **20**, L517 (1987).