

# On a Three-Phase Modular Double Salient Linear Motor's Optimal Control

Ioan-Adrian VIOREL – SZABÓ Loránd  
TECHNICAL UNIVERSITY OF CLUJ  
P.O. Box 358  
3400 Cluj, Romania  
Fax: +40-64-192-055  
e-mail: Ioan.Adrian.Viorel@mae.utcluj.ro

## Keywords

Linear drives, permanent magnet motors, variable speed drives, control, modelling.

## Abstract

The three-phase modular double salient permanent magnet linear motor (DSPMLM) has several advantages over the classical hybrid linear motor. In this paper an adjustable speed control system is proposed for this motor. The motor is energised simply from a low cost readily available standard three-phase compact converter, which is connected to a microcontroller-based intelligent speed control unit. A sensorless closed-loop control strategy based on the so-called back-EMF-voltage detection of the un-energized command coils is proposed. All the drive system's characteristics are analysed by means of simulation. The SIMULINK programs are based on a circuit-field mathematical model of the motor. The results obtained prove the ability of the motor and confirm the usefulness of the presented control strategy.

## 1. Introduction

In general terms, direct-drive linear motors have a lot of benefits [1]. As their name implies, the motor and load are directly and rigidly connected. The direct-drive linear motors can replace ballscrews, gear trains, belts, and pulleys, all off these being limiting factors for engineers trying to improve the linear drive system's performance. In the same way it is possible to suppress elasticity, backlash, hysteresis, and maintenance, too. All these create advantages in simplicity, efficiency, and positioning accuracy. The acceleration available from these motors is especially remarkable compared to traditional motor drives, which convert rotary motion to linear motion. Therefore these motors are ideal for applications that require high position accuracy and repeatability.

The three-phase modular double salient permanent magnet linear motor (DSPMLM) shown in Fig. 1, has essentially the same construction as a classical switched reluctance machine [2], with the single difference that it has high-energy magnets placed in the mover.

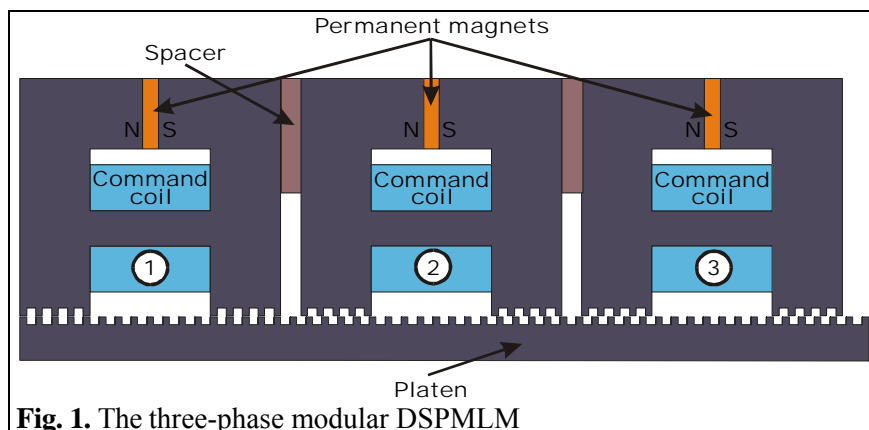
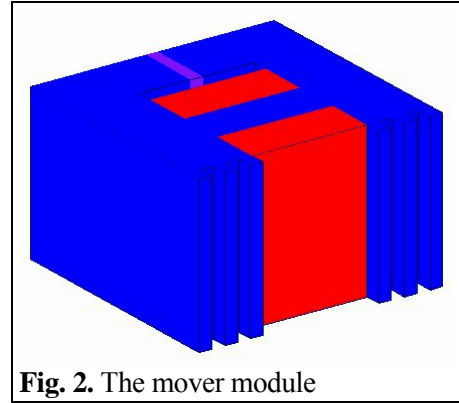

Fig. 1. The three-phase modular DSPMLM

The moveable armature is a single stack composed of three modules (presented in Fig. 2). Each module has a permanent magnet and a command coil placed on a core branch parallel to the permanent magnet [3]. If the command coil is energised adequately, its flux and the permanent magnet's flux will be forced to cross through the air-gap. If the command coil is not energised, its core acts as a shunt to the permanent magnet's flux, which does not cross the air-gap. In the first case the mover module will generate a significant tangential force. When the module is inactive, there is neither braking, nor attractive force produced. By energising the command coils sequentially with current pulses, the mover can travel linearly in both directions.



**Fig. 2.** The mover module

The above-presented high-efficiency linear motor construction can provide tangential force levels that allow high acceleration to shorten the cycle time in many applications. Fast acceleration with a heavy load is important for improving machine throughput. The motor offers particularly strong benefits in applications where fast and accurate moves under heavy loads are required (flexible manufacturing systems, robotic systems, machine tools, conveying systems, linear accelerators, turntable drives, automated warehousing etc.).

## 2. Motor control system

There are several control possibilities for the three-phase modular DSPMLM from the simplest open-loop control schemes to the most sophisticated and powerful variable speed drive systems. In the last case the speed can be modified from zero to many meters per second. The motor's speed capability can be determined by design and depends on the supply frequency. The stopping, starting and reversing of the motor are all easy to implement. From the numerous possibilities available the right decision must be made as to trade off the overall cost of the control system, maintaining the required control capabilities [4].

Sensorless closed-loop operation with high demands regarding the control quality is proposed to be applied. It is based on the so-called back-EMF-voltage detection of the un-energized command coils. The motor has three command coils, so there are always only one or two coils energised. Of course, in order to have continuous movement, the command coils needed for motion are always changing with the speed of the applied frequency, which means that the coils that are un-energized also change. The voltages induced in these coils provide an estimation of motor speed and position. The motor always starts from a well-defined initial position. In order to achieve maximum average tangential force (needed for the optimal efficiency) the command coils should always be energised at a precise moment, at the optimal commutation angle [5]. In this case the operating frequency will depend only on the capability of the motor to make a step under given conditions as load and input source limits. The speed controller commands the compact converter in function of the mover's position and speed. In such a way minimal current value is requested to obtain the necessary high tangential force. One limiting factor for the use of the back-EMF-voltage detection is that the motor must have a minimal speed so that the "unused" coils to be able to trigger the detection circuit.

As it was previously pointed out, to achieve maximum average tangential force and to reduce as much as possible the tangential force ripple the control system has to assure the change of excitation of the three module's command coils at a specific displacement, the optimal commutation angle ( $\alpha_o$ ), before reaching the intermediate equilibrium points. This value may be determined theoretically [6] and depends on the number of modules mounted together to form the mover. For a three-phase modular DSPMLM the optimal commutation angle is  $\alpha_o = -17.46^\circ$ . The two different commutation strategies are illustrated in Fig. 3.

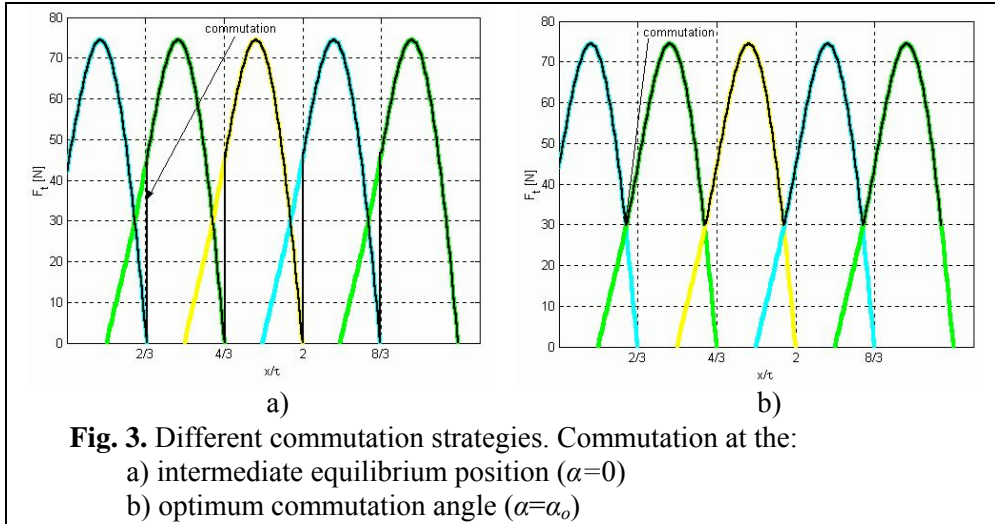

**Table I.**

Tangential force [N]	Commutation angle	
	$\alpha=0$	$\alpha=\alpha_o$
Minimum value	0	29.75
Maximal value	74.4	74.4
Mean value	53.39	56.95
Range	74.4	44.65

The data in Table I. highlights the benefits of the proposed commutation strategy. As it can be seen, for the proposed commutation strategy the mean value of the produced tangential force is increased with 6.67% and the force ripple is reduced with about 40%.

Table II. presents the sequence of energising the command coils for a displacement to the left, respectively to the right. In the initial position of the mover considered the teeth of the module 1 are aligned with the teeth of the platen (the position shown in Fig. 1). In Table II. the correspondence at each sequence between the supplied and the monitored un-energised coils (in which the back-EMF is detected) are also given. As it can be seen, each time a single command coil is supplied. For all the supplied command coils corresponds a monitored coil in both direction of displacement.

**Table II.**

Direction of displacement					
Left			Right		
Sequence number	Energised coil	Monitored coil	Sequence number	Energised coil	Monitored coil
I.	3	1	I.	2	1
II.	2	2	II.	3	2
III.	1	3	III.	1	3

The motor can be energised simply from a low cost readily available modern standard three-phase compact converter. This is connected to the microcontroller-based intelligent speed control unit [6]. The speed controller may be linked to PLCs or other control units (hosts) for general system supervision. A special unit detects the back EMF generated in the un-energised command coils. The whole control system is presented in Fig. 4.

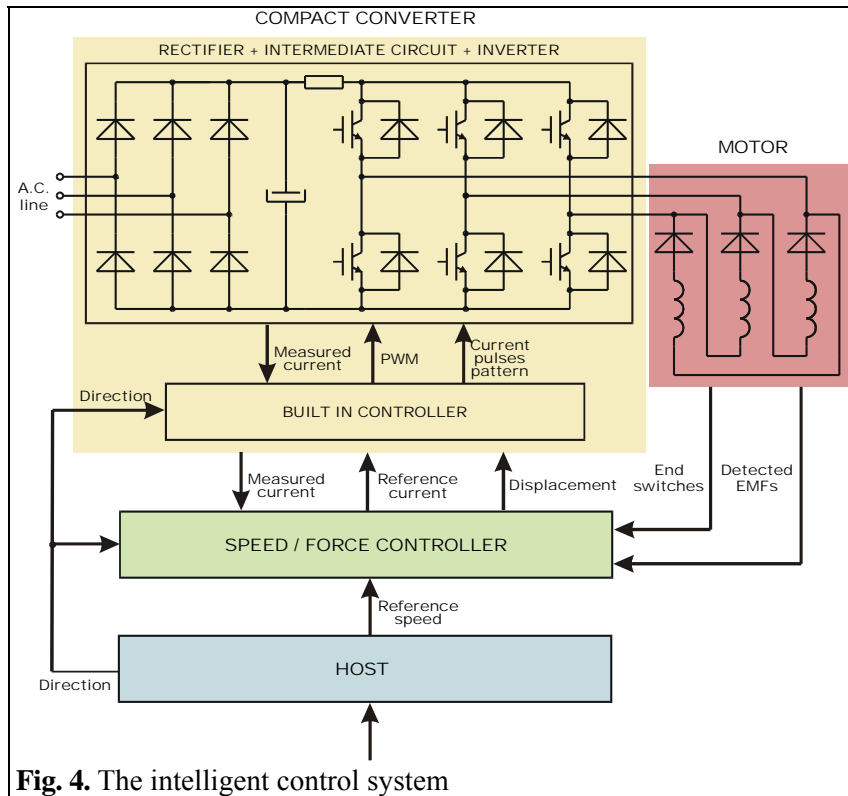

**Fig. 4.** The intelligent control system

In a standard three-phase compact converter the DC power supply is derived from the AC mains by rectification and smoothing. The output current is regulated by switching on or off the power devices (such as MOSFETs or IGBTs), which connect output to the internal DC bus. By its high efficient current feedback control system it allows fully independent precise control over the motor command coil's currents, so it can deliver precisely the current pulses as is required for the motor. It is simple to operate and to install or remove.

The three-phase modular DSPMLM cannot be simply supplied from the standard three-phase converter. The three command coils must be connected in a delta connection, with diodes placed in series with each winding [7]. Bi-directional command currents are not necessary since the generated tangential force is not function of the command current's polarity.

In the proposed control system the standard converter and motor are perfectly harmonised with one another. The converter can assure high degree of efficiency because it can save and carry out several sophisticated positioning programs for different (standard and non-standard) motor types due to the full range of features included. In addition the standard converter has a whole series of supplementary internal functions (input protection, temperature and current sensing), which are special benefits for the entire control system.

Due to its great computation capabilities the intelligent speed/force controller is an integral part of the control system. It remotely supervises the converter by a serial communication link. The controller provides the built-in controller of the converter with the reference current signal, obtained from reference speed input and the direction of movement, and with the estimated displacement of the mover. This is computed from the detected EMFs via a specific algorithm [4].

The converter's controller generates the PWM command signals of the inverter and also picks up from a table the proper current pulses pattern, function of the movement direction and the mover's actual position. One of the inputs for this control stage is the measured current obtained from a sensor placed in the intermediate d.c. circuit of the power converter.

The proposed control strategy has to be implemented using the adequate assembler language shared on the compact converter's built-in controller and on the speed/force controller unit.

### 3. Dynamic simulation

The proposed linear drive system's characteristics are analysed by means of computer dynamic simulation based on the simplified circuit-field mathematical model of the motor [8].

The main dimensions (in millimeters) of the sample motor's mover module are presented in Fig. 5. The most significant characteristics of the sample DSPMLM are given in Table III. It is a typical motor designed. The design procedure of this motor is presented detailed in [9].

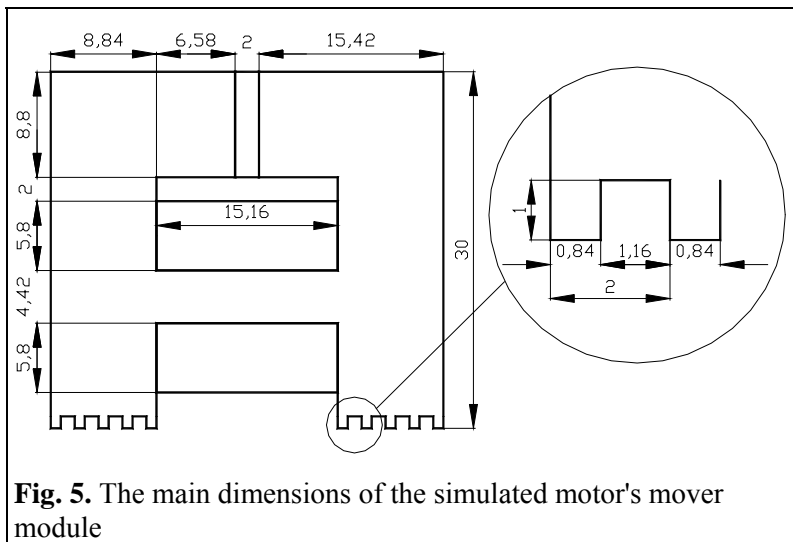
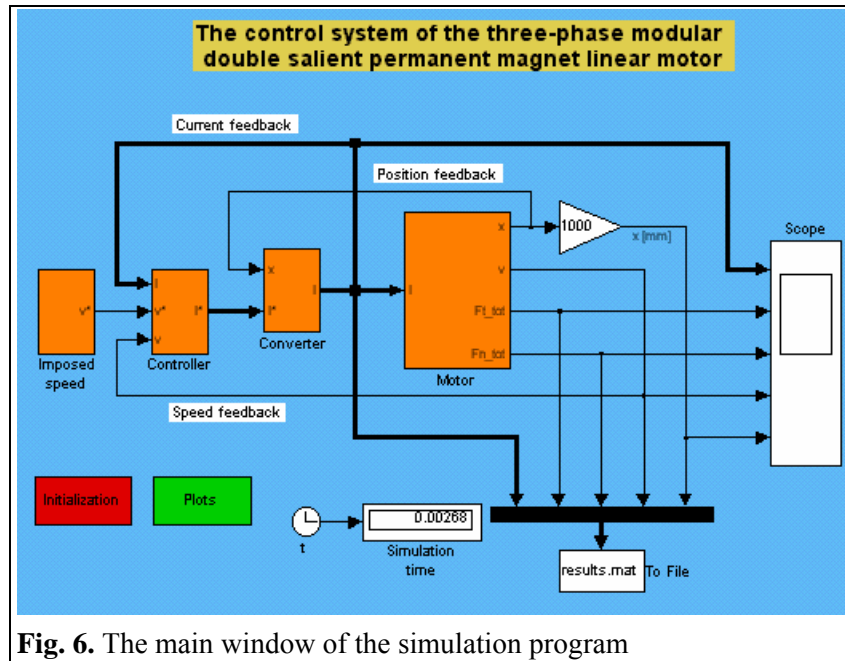

**Fig. 5.** The main dimensions of the simulated motor's mover module

**Table III.**

Number of mover modules	3
Number of teeth per pole	5
Tooth width	0.84 mm
Slot width	1.16 mm
Tooth pitch	2 mm
Rated command current	0,5 A
Nominal tangential force	75 N
Motor width	83 mm
Air-gap	0.1 mm
Permanent magnet type	VACOMAX 148
Residual flux density	0.9 T
Coercive force	650 KA/m

The model was implemented using the MATLAB/SIMULINK<sup>®</sup> environment [9]. The main part of the simulation program is shown in Fig. 6.



**Fig. 6.** The main window of the simulation program

The sub-system of the DSPMLM's mathematical model is given in Fig. 7.

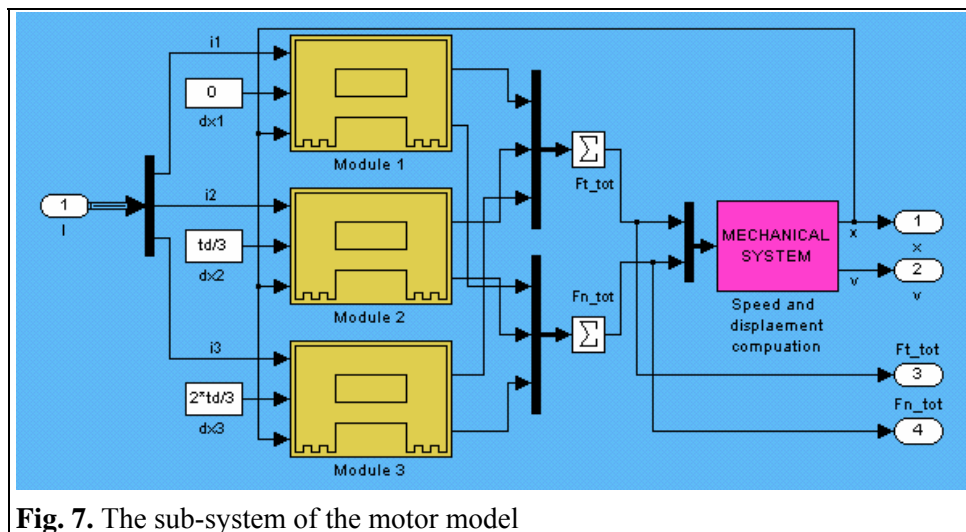

**Fig. 7.** The sub-system of the motor model

As it can be observed, the entire simulation program is built up in a modular manner (using sub-system type blocks), that assures a high transparency for the users. Therefore any changes in the program can be made quickly and easily.

As the major interest is the entire drive system's dynamic performance, only a simplified inverter model was applied, that simulates an ideal three-phase current source, having as output the three currents with the necessary amplitude and phase.

The results of simulating the no-load starting of the controlled motor follows. The imposed starting speed profile was a ramp-type one. The acceleration time was set to be 50 ms. After this the motor will run 50 ms at constant speed (3 m/s).

The main results (the three command currents, the total tangential and normal forces, the speed and the displacement of the motor plotted versus time are shown in Fig. 8.

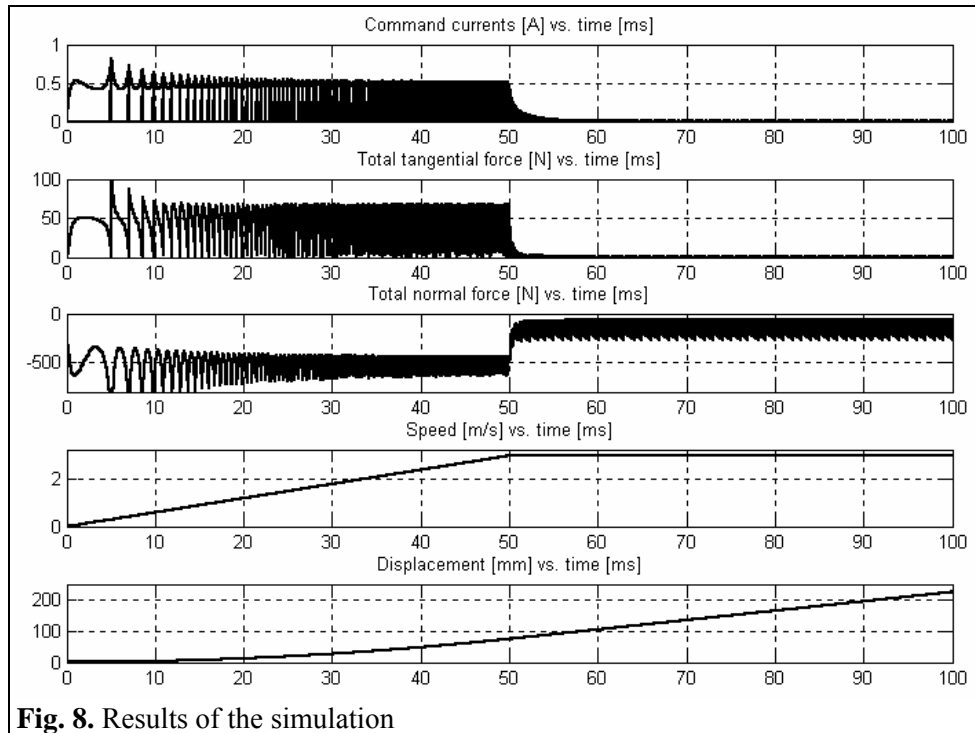

**Fig. 8.** Results of the simulation

As it can be seen, for accelerating the motor relatively high tangential force is needed. Due to the high force required the command currents for this stage have also significant values. After the mover was accelerated its imposed constant speed may be maintained by low tangential force. The actual speed of the motor follows very close the imposed speed profile.

## 4. Conclusions

The presented intelligent drive system offers several advantages. The entire system (composed of the drive control system, the electromagnetic device and the mechanical load) forms a single assemblage. This is much more efficient than trying to link different elements together. The use of the internal controller of the compact converter saves both software resources and hardware costs of the external speed/force controller.

All the results obtained prove the ability of the proposed high-efficiency three-phase modular double salient permanent magnet linear motor. The usefulness of the described optimal control strategy is also confirmed.

## 5. References

1. Wavre N. - Vaucher J-M.: *Motion Control with High Performance Direct Drives*, AMD&C Magazine, vol. 3., 2000, pp. 40-43.
2. Viorel I.A. - Szabó L. - Kovács Z.: *On the Switched Reluctance Linear Motor Positioning System Control*, Proceedings of the International Conference on Power Electronics, Drives and Motion (PCIM), Nürnberg, 1998, vol. Intelligent Motion, pp. 21-30.
3. Szabó L. - Viorel I.A. - Chişu I. - Kovács Z.: *A Novel Double Salient Permanent Magnet Linear Motor*, Proceedings of the International Conference on Power Electronics, Drives and Motion (PCIM), Nürnberg, 1999, vol. Intelligent Motion, pp. 285-290.
4. Henneberger G. - Viorel I.A.: *Variable Reluctance Electrical Machines*, Shaker Verlag, Aachen, 2001.
5. Viorel I.A. - Szabó L.: *Hybrid Linear Stepper Motors*, Mediamira Publisher, Cluj-Napoca (Romania), 1998.

6. Viorel I.A. - Szabó L.: *Permanent-Magnet Variable-Reluctance Linear Motor Control*, Electromotion, vol. 1., nr. 1. (1994), pp. 31-38.
7. Clothier A.C. - Mecrow B.C.: *The use of three phase bridge inverters with switching reluctance drives*, Proceedings of IEE-EMD 1997, pp. 351-355.
8. Viorel I.A. - Kovács Z. - Szabó L.: *Sawyer Type Linear Motor Modelling*, Proceedings of the International Conference on Electrical Machines (ICEM), Manchester, 1992, vol. 2., pp. 697-701.
9. Szabó L. - Viorel I.A.: *An Integrated CAD Environment for Designing and Simulating Double Salient Permanent Magnet Linear Motors*, Proceedings of the International Conference on Power Electronics, Drives and Motion (PCIM), Nürnberg, 2001, vol. Intelligent Motion (in press).
10. \*\*\*: *Using Simulink Version 4*, The MathWorks Inc, Natick, 2000.