



University of Pennsylvania
ScholarlyCommons

Technical Reports (CIS)

Department of Computer & Information Science

6-1-1992

On Feedback Linearization of Mobile Robots

Xiaoping Yun
University of Pennsylvania

Yoshio Yamamoto
University of Pennsylvania

Follow this and additional works at: https://repository.upenn.edu/cis_reports

 Part of the [Robotics Commons](#)

Recommended Citation

Xiaoping Yun and Yoshio Yamamoto, "On Feedback Linearization of Mobile Robots", . June 1992.

University of Pennsylvania Department of Computer and Information Science Technical Report No. MS-CIS-92-45.

This paper is posted at ScholarlyCommons. https://repository.upenn.edu/cis_reports/503
For more information, please contact repository@pobox.upenn.edu.

On Feedback Linearization of Mobile Robots

Abstract

A wheeled mobile robot is subject to both holonomic and nonholonomic constraints. Representing the motion and constraint equations in the state space, this paper studies the feedback linearization of the dynamic system of a wheeled mobile robot. The main results of the paper are: (1) It is shown that the system is not input-state linearizable. (2) If the coordinates of a point on the wheel axis are taken as the output equation, the system is not input-output linearizable by using a *static* state feedback; (3) but is input-output linearizable by using a *dynamic* state feedback. (4) If the coordinates of a reference point in front of the mobile robot are chosen as the output equation, the system is input-output linearizable by using a static state feedback. (5) The internal motion of the mobile robot when the reference point moves forward is asymptotically stable whereas the internal motion when the reference point moves backward is unstable. A nonlinear feedback is derived for each case where the feedback linearization is possible.

Disciplines

Robotics

Comments

University of Pennsylvania Department of Computer and Information Science Technical Report No. MS-CIS-92-45.

On Feedback Linearization of Mobile Robots

MS-CIS-92-45
GRASP LAB 321

Xiaoping Yun
Yoshio Yamamoto

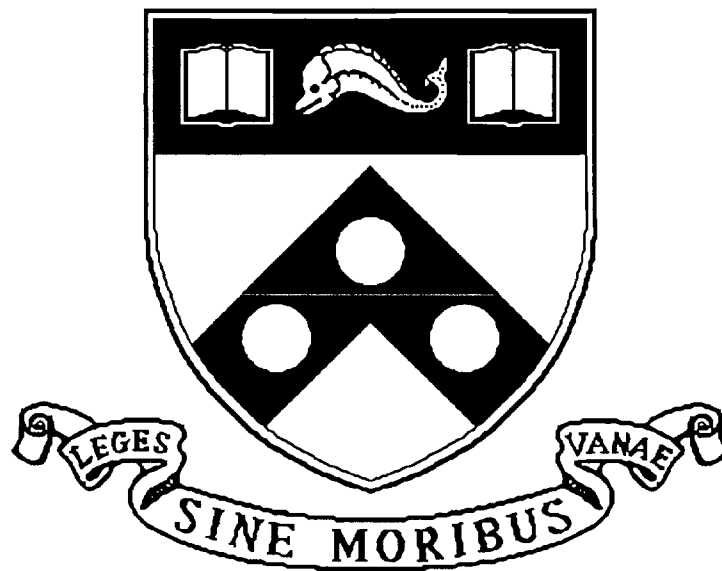

University of Pennsylvania
School of Engineering and Applied Science
Computer and Information Science Department
Philadelphia, PA 19104-6389

June 1992

On Feedback Linearization of Mobile Robots

Xiaoping Yun and Yoshio Yamamoto

General Robotics and Active Sensory Perception (GRASP) Laboratory
University of Pennsylvania
3401 Walnut Street, Room 301C
Philadelphia, PA 19104-6228

ABSTRACT

A wheeled mobile robot is subject to both holonomic and nonholonomic constraints. Representing the motion and constraint equations in the state space, this paper studies the feedback linearization of the dynamic system of a wheeled mobile robot. The main results of the paper are: (1) It is shown that the system is not input-state linearizable. (2) If the coordinates of a point on the wheel axis are taken as the output equation, the system is not input-output linearizable by using a *static* state feedback; (3) but is input-output linearizable by using a *dynamic* state feedback. (4) If the coordinates of a reference point in front of the mobile robot are chosen as the output equation, the system is input-output linearizable by using a static state feedback. (5) The internal motion of the mobile robot when the reference point moves forward is asymptotically stable whereas the internal motion when the reference point moves backward is unstable. A nonlinear feedback is derived for each case where the feedback linearization is possible.

This work is in part supported by NSF Grants CISE/CDA-90-2253, and CISE/CDA 88-22719, Navy Grant N0014-88-K-0630, NATO Grant CRG 911041, AFOSR Grants 88-0244 and 88-0296, Army/DAAL 03-89-C-0031PRI, and the University of Pennsylvania Research Foundation.

1 Introduction

The feedback linearization of nonlinear systems has been extensively studied in the literature [1, 2, 3, 4, 5]. Broadly speaking, there are two types of linearization: input-state linearization and input-output linearization. Necessary and sufficient conditions have been established for each type of linearization [6, 7]. For a given nonlinear system, these conditions can be checked to determine if the system is linearizable. Two types of feedback are commonly employed for the purpose of linearization: static state feedback and dynamic state feedback. The dynamic state feedback is more general and includes the static state feedback as a special case. Consequently, the conditions for the dynamic state feedback are more complicated.

In this paper, we study the feedback linearization of a wheeled mobile robot. Due to the fact that the wheeled mobile robot is nonholonomically constrained, the wheeled mobile robot possesses a number of distinguishing properties as far as the feedback linearization is concerned. In particular, we will first show that the dynamic system of a wheeled mobile robot is not input-state linearizable. We then study the input-output linearization of the system for two types of output equations which are chosen for the trajectory tracking of the mobile robot. The first output takes the coordinates of the center point on the wheel axis, and the other output takes the coordinates of a reference point in front of the mobile robot. With the first output equation, we should that the system is not input-output linearizable by using a static state feedback but is input-output linearizable by using a dynamic state feedback. The dynamic feedback achieving the input-output linearization is constructed following the dynamic extension algorithm [7, 8]. With the second type of output equation, the system is input-output linearizable by simply using a static state feedback. Nevertheless, the internal dynamics of the system is not always stable. Specifically, when the reference point is controlled to move backward, the internal motion of the system is unstable.

Although motion planning of mobile robots have been an active topic in robotics in the past decade [9, 10, 11, 12, 13], the study on the feedback control of mobile robots is very recent [14, 15, 16]. The work which is most closely related to the present study is by d'Andrea-Novel *et al.* [17] who studied full linearization of wheeled mobile robots. Since they used a reduced model, the motions of mobile robots are not completely characterized. In particular, the nonlinear internal dynamics, which are a major topic of this study, are excluded from the motion equations. Bloch and McClamroch [18] showed that a nonholonomic system, including wheeled mobile robot systems, cannot be stabilized to a single equilibrium point by a smooth feedback. Walsh *et al.* [19] suggested a control law to stabilize the nonholonomic system about a trajectory, instead of a point. Other relevant work includes [20, 21] which proved that systems with nonholonomic constraints are small-time locally controllable.

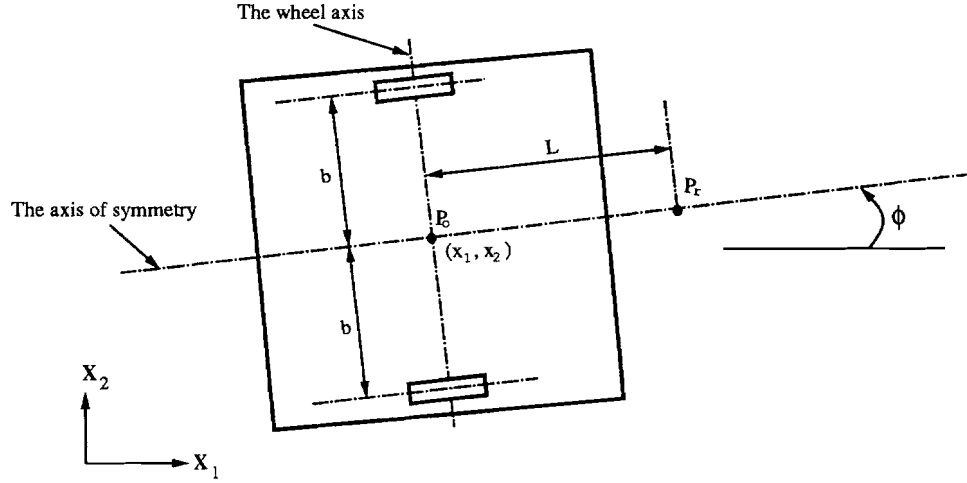

Figure 1: Schematic of the mobile robot.

2 Dynamics of a Wheeled Mobile Robot

2.1 Constraint Equations

In this section, we derive the motion equations and constraint equations of a wheeled mobile robot whose schematic top view is shown in Figure 1. We assume that the mobile robot is driven by two independent wheels and supported by four passive wheels at the corners (not shown in Figure 1). Before proceeding, let us fix some notations (see Figure 1).

- b : the displacement from each of the driving wheels to the axis of symmetry.
- d : the displacement from point P_o to the mass center of the mobile robot, which is assumed to be on the axis of symmetry.
- r : the radius of the driving wheels.
- c : $r/2b$.
- m_c : the mass of the mobile robot without the driving wheels and the rotors of the motors.
- m_w : the mass of each driving wheel plus the rotor of its motor.
- I_c : the moment of inertia of the mobile robot without the driving wheels and the rotors of the motors about a vertical axis through the intersection of the axis of symmetry with the driving wheel axis.
- I_w : the moment of inertia of each driving wheel and the motor rotor about the wheel axis.
- I_m : the moment of inertia of each driving wheel and the motor rotor about a wheel diameter.

There are three constraints. The first one is that the mobile robot can not move in lateral direction, *i.e.*,

$$\dot{x}_2 \cos \phi - \dot{x}_1 \sin \phi = 0 \quad (1)$$

where (x_1, x_2) is the coordinates of point P_o in the fixed reference coordinated frame \mathbf{X}_1 – \mathbf{X}_2 , and ϕ is the heading angle of the mobile robot measured from x_1 -axis. The other two constraints are that the two driving wheels roll and do not slip:

$$\dot{x}_1 \cos \phi + \dot{x}_2 \sin \phi + b\dot{\phi} = r\dot{\theta}_1 \quad (2)$$

$$\dot{x}_1 \cos \phi + \dot{x}_2 \sin \phi - b\dot{\phi} = r\dot{\theta}_2 \quad (3)$$

where θ_1 and θ_2 are the angular positions of the two driving wheels, respectively.

Let the generalized coordinates of the mobile robot be $q = (x_1, x_2, \phi, \theta_1, \theta_2)$. The three constraints can be written as follows

$$A(q)\dot{q} = 0 \quad (4)$$

where

$$A(q) = \begin{bmatrix} -\sin \phi & \cos \phi & 0 & 0 & 0 \\ -\cos \phi & -\sin \phi & -b & r & 0 \\ -\cos \phi & -\sin \phi & b & 0 & r \end{bmatrix} \quad (5)$$

We define a 5×2 dimensional matrix as follows

$$S(q) = [s_1(q) \ s_2(q)] = \begin{bmatrix} cb \cos \phi & cb \cos \phi \\ cb \sin \phi & cb \sin \phi \\ c & -c \\ 1 & 0 \\ 0 & 1 \end{bmatrix} \quad (6)$$

The two independent columns of matrix $S(q)$ are in the null space of matrix $A(q)$, that is, $A(q)S(q) = 0$. We define a distribution spanned by the columns of $S(q)$

$$\Delta = \text{span}\{s_1(q), \ s_2(q)\}$$

The involutivity of the distribution Δ determines the number of holonomic or nonholonomic constraints [21]. If Δ is involutive, from the Frobenius theorem [22], all the constraints are integrable (thus holonomic). If the smallest involutive distribution containing Δ (denoted by Δ^*) spans the entire 5-dimensional space, all the constraints are nonholonomic. If $\dim(\Delta^*) = 5 - k$, then k constraints are holonomic and the others are nonholonomic.

To verify the involutivity of Δ , we compute the Lie bracket of $s_1(q)$ and $s_2(q)$.

$$s_3(q) = [s_1(q), \ s_2(q)] = \frac{\partial s_2}{\partial q} s_1 - \frac{\partial s_1}{\partial q} s_2 = \begin{bmatrix} -rc \sin \phi \\ rc \cos \phi \\ 0 \\ 0 \\ 0 \end{bmatrix}$$

which is not in the distribution Δ spanned by $s_1(q)$ and $s_2(q)$. Therefore, at least one of the constraints is nonholonomic. We continue to compute the Lie bracket of $s_1(q)$ and $s_3(q)$

$$s_4(q) = [s_1(q), s_3(q)] = \frac{\partial s_3}{\partial q} s_1 - \frac{\partial s_1}{\partial q} s_3 = \begin{bmatrix} -rc^2 \cos \phi \\ -rc^2 \sin \phi \\ 0 \\ 0 \\ 0 \end{bmatrix}$$

which is linearly independent of $s_1(q)$, $s_2(q)$, and $s_3(q)$. However, the distribution spanned by $s_1(q)$, $s_2(q)$, $s_3(q)$ and $s_4(q)$ is involutive. Therefore, we have

$$\Delta^* = \text{span}\{s_1(q), s_2(q), s_3(q), s_4(q)\} \quad (7)$$

It follows that, among the three constraints, two of them are nonholonomic and the third one is holonomic. To obtain the holonomic constraint, we subtract equation (2) from equation (3).

$$2b\dot{\phi} = r(\dot{\theta}_r - \dot{\theta}_l) \quad (8)$$

Integrating the above equation and properly choosing the initial condition of ϕ , θ_r , and θ_l , we have

$$\phi = c(\theta_r - \theta_l) \quad (9)$$

which is clearly a holonomic constraint equation. Thus ϕ may be eliminated from the generalized coordinates. The new generalized coordinates are 4-dimensional, which will be denoted by q again.

$$q = \begin{bmatrix} q_1 \\ q_2 \\ q_3 \\ q_4 \end{bmatrix} = \begin{bmatrix} x_1 \\ x_2 \\ \theta_1 \\ \theta_2 \end{bmatrix} \quad (10)$$

The two nonholonomic constraints are

$$\dot{x}_1 \sin \phi - \dot{x}_2 \cos \phi = 0 \quad (11)$$

$$\dot{x}_1 \cos \phi + \dot{x}_2 \sin \phi = cb(\dot{\theta}_1 + \dot{\theta}_2) \quad (12)$$

where $cb = \frac{r}{2}$ as defined early. The second nonholonomic constraint equation in the above is obtained by adding equations (2) and (3). It is understood that ϕ is now a short-hand notation for $c(\theta_1 - \theta_2)$ rather than an independent variable. We write these two constraint equations in matrix form

$$A(q)\dot{q} = 0 \quad (13)$$

where q is now defined in equation (10) and $A(q)$ is given below

$$A(q) = \begin{bmatrix} a_{11} & a_{12} & a_{13} & a_{14} \\ a_{21} & a_{22} & a_{23} & a_{24} \end{bmatrix} = \begin{bmatrix} -\sin \phi & \cos \phi & 0 & 0 \\ -\cos \phi & -\sin \phi & cb & cb \end{bmatrix} \quad (14)$$

2.2 Dynamic Equations

We use the Lagrange formulation to establish equations of motion for the mobile robot. The total kinetic energy of the mobile base and the two wheels is

$$K = \frac{1}{2}m(\dot{x}_1^2 + \dot{x}_2^2) + m_c d(\dot{\theta}_1 - \dot{\theta}_2)(\dot{x}_2 \cos \phi - \dot{x}_1 \sin \phi) + \frac{1}{2}I_w(\dot{\theta}_1^2 + \dot{\theta}_2^2) + \frac{1}{2}Ic^2(\dot{\theta}_1 - \dot{\theta}_2)^2 \quad (15)$$

where

$$\begin{aligned} m &= m_c + 2m_w \\ I &= I_c + 2m_w b^2 + 2I_m \end{aligned}$$

Lagrange equations of motion for the nonholonomic mobile robot system are governed by [23]

$$\frac{d}{dt}\left(\frac{\partial K}{\partial \dot{q}_i}\right) - \frac{\partial K}{\partial q_i} = f_i - a_{1i}\lambda_1 - a_{2i}\lambda_2, \quad i = 1, \dots, 4 \quad (16)$$

where q_i is the generalized coordinate defined in equation (10), f_i is the generalized force, a_{ij} is from the constraint equation (14), and λ_1 and λ_2 are the Lagrange multipliers. Substituting the total kinetic energy (equation (15)) into equation (16), we obtain

$$m\ddot{x}_1 - m_c d(\ddot{\phi} \sin \phi + \dot{\phi}^2 \cos \phi) = \lambda_1 \sin \phi + \lambda_2 \cos \phi \quad (17)$$

$$m\ddot{x}_2 + m_c d(\ddot{\phi} \cos \phi - \dot{\phi}^2 \sin \phi) = -\lambda_1 \cos \phi + \lambda_2 \sin \phi \quad (18)$$

$$m_c d(\ddot{x}_2 \cos \phi - \ddot{x}_1 \sin \phi) + (Ic^2 + I_w)\ddot{\theta}_1 - Ic^2\ddot{\theta}_2 = \tau_1 - cb\lambda_2 \quad (19)$$

$$-m_c d(\ddot{x}_2 \cos \phi - \ddot{x}_1 \sin \phi) - Ic^2\ddot{\theta}_1 + (Ic^2 + I_w)\ddot{\theta}_2 = \tau_2 - cb\lambda_2 \quad (20)$$

where τ_1 and τ_2 are the torques acting on the two wheels. These equations can be written in the matrix form

$$M(q)\ddot{q} + V(q, \dot{q}) = E(q)\tau - A^T(q)\lambda \quad (21)$$

where $A(q)$ is defined in equation (14) and

$$\begin{aligned} M(q) &= \begin{bmatrix} m & 0 & -m_c d \sin \phi & m_c d \sin \phi \\ 0 & m & m_c d \cos \phi & -m_c d \cos \phi \\ -m_c d \sin \phi & m_c d \cos \phi & Ic^2 + I_w & -Ic^2 \\ m_c d \sin \phi & -m_c d \cos \phi & -Ic^2 & Ic^2 + I_w \end{bmatrix} \\ V(q, \dot{q}) &= \begin{bmatrix} -m_c d \dot{\phi}^2 \cos \phi \\ -m_c d \dot{\phi}^2 \sin \phi \\ 0 \\ 0 \end{bmatrix} \quad E(q) = \begin{bmatrix} 0 & 0 \\ 0 & 0 \\ 1 & 0 \\ 0 & 1 \end{bmatrix} \quad \tau = \begin{bmatrix} \tau_1 \\ \tau_2 \end{bmatrix} \quad \lambda = \begin{bmatrix} \lambda_1 \\ \lambda_2 \end{bmatrix} \end{aligned}$$

2.3 State Space Realization

In this subsection, we establish a state space realization of the motion equation (21) and constraint equation (13). Let $S(q)$ be a 4×2 matrix

$$S(q) = [s_1(q) \quad s_2(q)] = \begin{bmatrix} cb \cos \phi & cb \cos \phi \\ cb \sin \phi & cb \sin \phi \\ 1 & 0 \\ 0 & 1 \end{bmatrix} \quad (22)$$

whose columns are in the null space of $A(q)$ matrix in the constraint equation (13), *i.e.*, $A(q)S(q) = 0$. From the constraint equation (13), the velocity \dot{q} must be in the null space of $A(q)$. It follows that $\dot{q} \in \text{span}\{s_1(q), s_2(q)\}$, and that there exists a smooth vector $\eta = [\eta_1 \quad \eta_2]^T$ such that

$$\dot{q} = S(q)\eta \quad (23)$$

and

$$\ddot{q} = S(q)\dot{\eta} + \dot{S}(q)\eta \quad (24)$$

For the specific choice of $S(q)$ matrix in equation (22), we have $\eta = \dot{\theta}$, where $\dot{\theta} = [\dot{\theta}_1 \quad \dot{\theta}_2]^T$.

Now multiplying the both sides of equation (21) by $S^T(q)$ and noticing that $S^T(q)A^T(q) = 0$ and $S^T(q)E(q) = I_{2 \times 2}$ (the 2×2 identity matrix), we obtain

$$S^T(q)M(q)\ddot{q} + S^T(q)V(q, \dot{q}) = S^T(q)E(q)\tau = \tau \quad (25)$$

Substituting equation (24) into the above equation, we have

$$S^T(q)M(q)(S(q)\dot{\eta} + \dot{S}(q)\eta) + S^T(q)V(q, \dot{q}) = \tau \quad (26)$$

By choosing the following state variable

$$x = \begin{bmatrix} x_1 \\ x_2 \\ x_3 \\ x_4 \\ x_5 \\ x_6 \end{bmatrix} = \begin{bmatrix} x_1 \\ x_2 \\ \theta_1 \\ \theta_2 \\ \eta_1 \\ \eta_2 \end{bmatrix} = \begin{bmatrix} q \\ \eta \end{bmatrix} \quad (27)$$

we may represent the motion equation (26) in the state space form

$$\dot{x} = f(x) + g(x)\tau \quad (28)$$

where

$$f(x) = \begin{bmatrix} S\eta \\ -(S^TMS)^{-1}(S^TMS\dot{S}\eta + S^TV) \end{bmatrix}, \quad g(x) = \begin{bmatrix} 0 \\ (S^TMS)^{-1} \end{bmatrix}$$

It is noted that the dependent variables for each term have been omitted in the above representation for clarity. All the terms are functions of the state variable x only. Since \dot{q} is not part of the state variable, it is replaced by $S(q)\eta$.

3 Input-State Linearization

In this section, we study the input-state linearization of the control system (28) using smooth nonlinear feedbacks. To simplify the discussion, we first apply the following state feedback

$$\begin{aligned}\tau &= \alpha^1(x) + \beta^1(x)\mu \\ &= (S^T M \dot{S}\eta + S^T V) + (S^T M S)S^T E\mu\end{aligned}\quad (29)$$

where μ is the new input variable. The closed-loop system becomes

$$\dot{x} = f^1(x) + g^1(x)\mu \quad (30)$$

where

$$f^1(x) = \begin{bmatrix} S\eta \\ 0 \end{bmatrix} \quad g^1(x) = \begin{bmatrix} 0 \\ I_{2 \times 2} \end{bmatrix}$$

Theorem 1 *System (30) is not input-state linearizable by a smooth state feedback.*

Proof: If the system is input-state linearizable, it has to satisfy two conditions : the strong accessibility condition and the involutivity condition [7, p.179]. We will show that the system does not satisfy the involutivity condition.

Define a sequence of distributions

$$D_j = \text{span}\{L_{f^1}^i g^1 \mid i = 0, 1, \dots, j-1\}, \quad j = 1, 2, \dots$$

Then the involutivity condition requires that the distributions D_1, D_2, \dots, D_6 be all involutive, with 6 being the dimension of the system. $D_1 = \text{span}\{g^1\}$ is involutive since g^1 is constant. Next we compute

$$L_{f^1} g^1 = [f^1, g^1] = \frac{\partial g^1}{\partial x} f^1 - \frac{\partial f^1}{\partial x} g^1 = - \begin{bmatrix} S(q) \\ 0 \end{bmatrix}$$

It is easy to verify that the distribution spanned by the columns of $S(q)$ is not involutive. (Actually, if the distribution were involutive, the two constraints (11) and (12) would be holonomic.) It follows that the distribution $D_2 = \text{span}\{g^1, L_{f^1} g^1\}$ is not involutive. Therefore, the system is not input-state linearizable. \square

Corollary 1 *System (28) is not input-state linearizable by a smooth state feedback.*

Proof: A proof similar to that of Theorem 1 can be carried out. Alternatively, system (30) can be regarded as a special case of system (28).

4 Input-Output Linearization and Decoupling

Although the dynamic system of a wheeled mobile robot is not input-state linearizable as shown in the previous section, it may be input-output linearizable. In this section, we study the input-output linearization of two types of outputs. First, the coordinates of the center point P_o are chosen as the output equation. It will be shown that the input-output linearization is not possible by using static state feedback, but is possible by using a dynamic state feedback. Second, the coordinates of a reference point P_r in front of the mobile robot is chosen as the output equation. In this case, the input-output linearization can be achieved by using a static state feedback. Nevertheless, the internal dynamics when the mobile robot moves backwards is unstable.

4.1 Controlling the Center Point P_o

Since the mobile robot has two inputs, we may choose an output equation with two independent components. A natural choice for the output equation is the coordinates of the center point P_o , *i.e.*,

$$y = h(x) = \begin{bmatrix} x_1 \\ x_2 \end{bmatrix}. \quad (31)$$

Together with this output equation, we will consider the state equation (30), assuming that the nonlinear feedback (29) is applied to cancel the dynamic nonlinearity. To verify if the system is input-output linearizable, we compute the time derivatives of y .

$$\dot{y} = \frac{\partial h}{\partial x} \dot{x} = \frac{\partial h}{\partial x} (f^1(x) + g^1(x)\mu) = S_1(x)\eta$$

where

$$S_1(x) = \begin{bmatrix} cb \cos \phi & cb \cos \phi \\ cb \sin \phi & cb \sin \phi \end{bmatrix}$$

Since \dot{y} is not a function of the input μ , we differentiate once more.

$$\ddot{y} = S_1(x)\dot{\eta} + \dot{S}_1(x)\eta = S_1(x)\mu + \dot{S}_1(x)\eta \quad (32)$$

where the second term on the right-hand side is evaluated to be

$$\dot{S}_1(x)\eta = c^2 b (\eta_1^2 - \eta_2^2) \begin{bmatrix} -\sin \phi \\ \cos \phi \end{bmatrix}$$

Now that \ddot{y} is a function of the input μ , the decoupling matrix of the system is $S_1(x)$. Since $S_1(x)$ is singular, the system is not input-output linearizable and the output can not be decoupled by using any static state feedback [6, 14, 15].

4.2 Dynamic Feedback Control

As shown above, the mobile robot under the output equation (31) is not input-output linearizable with any static feedback of the form

$$\mu = \alpha(x) + \beta(x)u \quad (33)$$

Nevertheless the input-output linearization may be achieved by using a dynamic feedback of the form [7, 24, 25, 26, 8]

$$\dot{\xi} = f_{\xi}(x, \xi) + g_{\xi}(x, \xi)u \quad (34)$$

$$\mu = \alpha(x, \xi) + \beta(x, \xi)u \quad (35)$$

We follow the dynamic extension algorithm [7, pp.258-269] to derive $f_{\xi}(\cdot, \cdot)$, $g_{\xi}(\cdot, \cdot)$, $\alpha(\cdot, \cdot)$, and $\beta(\cdot, \cdot)$ if they exist at all. We divide the algorithm in three steps.

Step 1: Since the rank of the decoupling matrix $S_1(x)$ in equation (32) is *one*, we first apply a static feedback to linearize and decouple *one* output from the others. For the mobile robot, there are two outputs $y = [y_1 \ y_2]^T$. We choose to linearize y_1 and decouple it from y_2 . Substituting the following static feedback into equation (32)

$$\mu = \alpha^2(x) + \beta^2(x)u = \begin{bmatrix} c(\eta_1^2 - \eta_2^2) \tan \phi \\ 0 \end{bmatrix} + \begin{bmatrix} \frac{1}{cb \cos \phi} & 1 \\ 0 & -1 \end{bmatrix} \begin{bmatrix} u_1 \\ u_2 \end{bmatrix} \quad (36)$$

the closed-loop input-output map is then

$$\ddot{y} = \begin{bmatrix} 0 \\ c^2 b (\eta_1^2 - \eta_2^2) \frac{1}{\cos \phi} \end{bmatrix} + \begin{bmatrix} 1 & 0 \\ \tan \phi & 0 \end{bmatrix} \begin{bmatrix} u_1 \\ u_2 \end{bmatrix} \quad (37)$$

It is clear that $\ddot{y}_1 = u_1$, that is, the first output y_1 is linearized and controlled only by u_1 . Thus u_1 can be designed to achieve the performance requirements for y_1 . On the other hand, y_2 is still nonlinear. Further, it is also driven by u_1 .

Step 2: We substitute the static feedback (36) into equation (30) to obtain the new state equation

$$\dot{x} = f^1(x) + g^1(x)\mu = f^1(x) + g^1(x) (\alpha^2(x) + \beta^2(x)u) \quad (38)$$

$$= \begin{bmatrix} S\eta \\ c(\eta_1^2 - \eta_2^2) \tan \phi \\ 0 \end{bmatrix} + \begin{bmatrix} 0 & 0 \\ \frac{1}{cb \cos \phi} & 1 \\ 0 & -1 \end{bmatrix} \begin{bmatrix} u_1 \\ u_2 \end{bmatrix} = f^2(x) + g^2(x)u \quad (39)$$

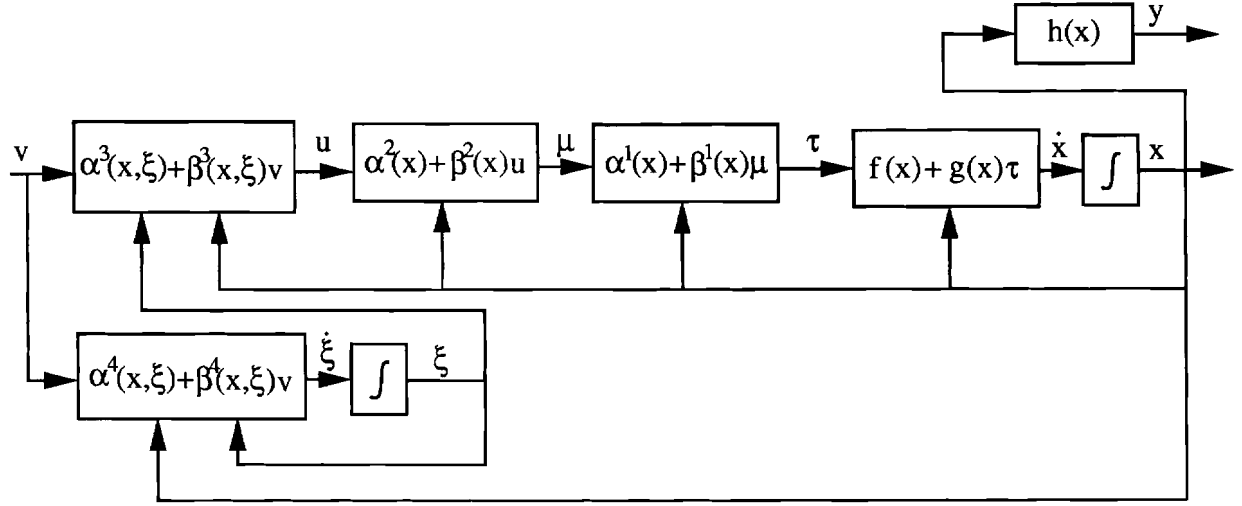

Figure 2: Dynamic feedback controller of a mobile robot.

We now differentiate the second output with respect to the new state equation $\dot{x} = f^2(x) + g^2(x)u$, hoping that u_2 will appear in the derivative of y_2 . In the following differentiation, u_1 is treated as a (time-varying) parameter.

$$\begin{aligned}
 \dot{y}_2 &= cb(\eta_1 + \eta_2) \sin \phi \\
 \ddot{y}_2 &= c^2 b(\eta_1^2 - \eta_2^2) \frac{1}{\cos \phi} + \tan \phi u_1 \\
 y_2^{(3)} &= c^3 b(\eta_1^2 - \eta_2^2)(\eta_1 - \eta_2) \frac{\sin \phi}{\cos^2 \phi} + c(\eta_1 - \eta_2) \frac{u_1}{\cos^2 \phi} \\
 &\quad + \frac{2c^2 b \eta_1}{\cos \phi} \left(c(\eta_1^2 - \eta_2^2) \tan \phi + \frac{u_1}{cb \cos \phi} \right) \\
 &\quad + \tan \phi \dot{u}_1 + \frac{2c^2 b(\eta_1 + \eta_2)}{\cos \phi} u_2
 \end{aligned}$$

It is seen that u_2 appears in the third-order derivative of y_2 . We note that $y_2^{(3)}$ has the following structure

$$y_2^{(3)} = Q_1(x) + Q_2(x)u_1 + Q_3\dot{u}_1 + Q_4u_2 \quad (40)$$

where $Q_i(x)$ can be easily identified.

Step 3: Noting equation (40), y_2 will be linearized if we apply the following feedback

$$u_2 = Q_4^{-1}(x)(v_2 - Q_1(x) - Q_2(x)u_1 - Q_3(x)\dot{u}_1) \quad (41)$$

with v being the reference input. However, this feedback depends on \dot{u}_1 , which can be eliminated by introducing an integrator on the first input channel. Formally, we utilize the

following dynamic feedback

$$\dot{\xi} = \alpha^4(x, \xi) + \beta^4(x, \xi)v \quad (42)$$

$$u = \alpha^3(x, \xi) + \beta^3(x, \xi)v \quad (43)$$

where ξ is one-dimensional and

$$\begin{aligned} \alpha^4(x, \xi) &= 0 \\ \beta^4(x, \xi) &= [1 \ 0] \\ \alpha^3(x, \xi) &= \begin{bmatrix} \xi \\ -Q_4^{-1}(x)(Q_1(x) + Q_2\xi) \end{bmatrix} \\ \beta^3(x, \xi) &= \begin{bmatrix} 0 & 0 \\ -Q_4^{-1}(x)Q_3(x) & Q_4^{-1}(x) \end{bmatrix} \end{aligned}$$

After applying the above dynamic feedback, we finally obtain two linearized and decoupled subsystems:

$$y_1^{(3)} = v_1 \quad (44)$$

$$y_2^{(3)} = v_2 \quad (45)$$

It is noted that the first subsystem is now of third order due to the introduction of the integrator on its input channel. This concludes the dynamic extension algorithm. The resulting extended system hence is decouplable with static state feedback.

The overall dynamic feedback control of the mobile robot is depicted in Figure 2. The first feedback (29) is to cancel the dynamic nonlinearity in order to simplify the subsequent discussion. The second feedback (36) is to linearize y_1 and also decouple it from y_2 . The third feedback represented by equations (42) and (43) is to linearize y_2 .

Finally we comment on the invertibility of the system [27, 28, 29]. Since the differential output rank ρ^* of this particular system is computed by [8]

$$\rho^* = \text{rank} \left(\frac{\partial y^{(3)}}{\partial v} \right) = 2$$

which is equal to the number of outputs, the system is right-invertible [27]. This guarantees the success of the above dynamic extension algorithm since a right-invertible system can always be locally decoupled via a dynamic state feedback [27]. Furthermore, since the different output rank is equal to the number of inputs, the system is also left-invertible [28, 29, 30].

4.3 Look-Ahead Control

In Section 4.1, we showed that the center point P_o of the mobile robot cannot be controlled by using a static feedback. A dynamic feedback is necessary. In this section, we present

an alternative control method. The method is motivated from vehicle maneuvering. When operating a vehicle, a driver looks at a point or an area in front of the vehicle. We define a reference point P_r which is L distance (called look-ahead distance) from P_o (see Figure 1). We take the coordinates of P_r in the fixed coordinate frame as the output equation, *i.e.*,

$$y = h(x) = \begin{bmatrix} x_1 + L \cos \phi \\ x_2 + L \sin \phi \end{bmatrix} \quad (46)$$

To verify if the system is input-output linearizable with this output equation, we compute the derivatives of y .

$$\begin{aligned} \dot{y} &= \frac{\partial h}{\partial x} \dot{x} = \frac{\partial h}{\partial x} (f^1(x) + g^1(x)\mu) \\ &= \begin{bmatrix} cb \cos \phi - cL \sin \phi & cb \cos \phi + cL \sin \phi \\ cb \sin \phi + cL \cos \phi & cb \sin \phi - cL \cos \phi \end{bmatrix} \begin{bmatrix} \eta_1 \\ \eta_2 \end{bmatrix} = \Phi(x)\eta \end{aligned}$$

Since \dot{y} is not a function of the input μ , we differentiate it once more.

$$\ddot{y} = \Phi(x)\dot{\eta} + \dot{\Phi}(x)\eta = \Phi(x)\mu + \dot{\Phi}(x)\eta$$

The input μ shows up in the second order derivative of y . Clearly, the decoupling matrix in this case is $\Phi(x)$. Since the determinant of $\Phi(x)$ is $(-2c^2bL)$, it is nonsingular as long as the look-ahead distance L is not zero. It follows that the system can be input-output linearized and decoupled [6]. The nonlinear feedback for achieving the input-output linearization and decoupling is

$$\mu = \Phi^{-1}(x) (u - \dot{\Phi}(x)\eta) \quad (47)$$

Applying this nonlinear feedback, we obtain

$$\ddot{y}_1 = u_1 \quad (48)$$

$$\ddot{y}_2 = u_2 \quad (49)$$

Therefore, the mobile robot can be controlled so that the reference point P_r tracks a desired trajectory. The motion of the mobile robot itself, particularly the motion of the center point P_o , is determined by the internal dynamics of the system which is the topic of the next section. We note that the look-ahead control method degenerates to the control of the center point if $L = 0$.

4.4 Internal Dynamics

The previous section addresses the input-output properties of the mobile robot with the look-ahead control output equation (46). In this section, we proceed to study the behavior of the internal dynamics including the zero dynamics of the system. For a general discussion of internal dynamics and zero dynamics, see Chapter 5 of [31].

We first construct a diffeomorphism by which the overall system can be represented in the norm form of nonlinear systems [31]. Since the relative degree of each output is two,

we may construct four components of the needed diffeomorphism from the two outputs and its Lie derivative, *i.e.*, $h_1(x)$, $L_f h_1(x)$, $h_2(x)$ and $L_f h_2(x)$. Since the state variable x is six dimensional, we need two more components. We choose the two components to be θ_1 and θ_2 . Thus the proposed diffeomorphic transformation would be

$$z = T(x) = \begin{bmatrix} z_1 \\ z_2 \\ z_3 \\ z_4 \\ z_5 \\ z_6 \end{bmatrix} = \begin{bmatrix} h_1(x) \\ L_f h_1(x) \\ h_2(x) \\ L_f h_2(x) \\ \theta_1 \\ \theta_2 \end{bmatrix} \quad (50)$$

To verify that $T(x)$ is indeed a diffeomorphism, we compute its Jacobian.

$$\frac{\partial T}{\partial x} = \begin{bmatrix} 1 & 0 & -cL \sin \phi & cL \sin \phi & 0 & 0 \\ 0 & 0 & * & * & cb \cos \phi - cL \sin \phi & cb \cos \phi + cL \sin \phi \\ 0 & 1 & cL \cos \phi & -cL \cos \phi & 0 & 0 \\ 0 & 0 & * & * & cb \sin \phi + cL \cos \phi & cb \sin \phi - cL \cos \phi \\ 0 & 0 & 1 & 0 & 0 & 0 \\ 0 & 0 & 0 & 1 & 0 & 0 \end{bmatrix}$$

It is easy to check that $\frac{\partial T}{\partial x}$ has full rank¹. Thus $T(x)$ is a valid state space transformation. The inverse transformation $T^{-1}(z)$ is given by

$$\begin{aligned} x_1 &= z_1 - L \cos(cz_5 - cz_6) \\ x_2 &= z_3 - L \sin(cz_5 - cz_6) \\ \theta_1 &= z_5 \\ \theta_2 &= z_6 \\ \begin{bmatrix} \eta_1 \\ \eta_2 \end{bmatrix} &= \Phi^{-1} \begin{bmatrix} z_2 \\ z_4 \end{bmatrix} \end{aligned}$$

We partition the state variable z into two blocks

$$\begin{aligned} z^1 &= \begin{bmatrix} z_1 & z_2 & z_3 & z_4 \end{bmatrix}^T \\ z^2 &= \begin{bmatrix} z_5 & z_6 \end{bmatrix}^T \end{aligned}$$

After applying the feedback (47), the system of the mobile robot is represented in the following normal form.

$$\dot{z}^1 = Az^1 + Bu \quad (51)$$

$$\dot{z}^2 = w(z^1, z^2) \quad (52)$$

$$y = Cz^1 \quad (53)$$

¹The terms denoted by * do not affect the computation of the rank.

where

$$A = \begin{bmatrix} 0 & 1 & 0 & 0 \\ 0 & 0 & 0 & 0 \\ 0 & 0 & 0 & 1 \\ 0 & 0 & 0 & 0 \end{bmatrix}, \quad B = \begin{bmatrix} 0 & 0 \\ 1 & 0 \\ 0 & 0 \\ 0 & 1 \end{bmatrix}, \quad C = \begin{bmatrix} 1 & 0 & 0 & 0 \\ 0 & 0 & 1 & 0 \end{bmatrix}$$

$$w(z^1, z^2) = \Phi^{-1}(z) \begin{bmatrix} z_2 \\ z_4 \end{bmatrix} = -\frac{1}{2c^2bL} \begin{bmatrix} cb \sin \phi - cL \cos \phi & -cb \cos \phi - cL \sin \phi \\ -cb \sin \phi - cL \cos \phi & cb \cos \phi - cL \sin \phi \end{bmatrix} \begin{bmatrix} z_2 \\ z_4 \end{bmatrix}$$

It is understood that ϕ in the expression of $w(z^1, z^2)$ is a short-hand notation for $c(z_5 - z_6)$. Together, the linear state equation (51) and the linear output equation (53) are an equivalent representation of the input-output map (equations (48) and (49)). Equation (52) represents the unobservable internal dynamics of the mobile robot under the look-ahead control.

The zero dynamics of a control system is defined as the dynamics of the system when the outputs are identically zero (*i.e.*, $y = 0, \dot{y} = 0, \ddot{y} = 0, \dots$). If the outputs are identically zero, it implies that $z^1 = 0$, and the zero dynamics is

$$\dot{z}^2 = w(0, z^2) = 0 \quad (54)$$

Thus, z^2 remains constant while the outputs are identically zero. The zero dynamics is stable but not asymptotically stable. In other words, if the reference point P_r remains still, so does the mobile robot (or more specifically, the wheels do not move).

We now look at the internal dynamics while the reference point is in motion. More specifically, we are interested in the internal motion of the mobile robot when it moves straight forward or backward. Let the mobile robot be initially headed in the positive \mathbf{X}_1 direction. We assume that the reference point is controlled to move in the negative \mathbf{X}_1 direction. The velocity of the reference point is then

$$\begin{bmatrix} \dot{y}_1 \\ \dot{y}_2 \end{bmatrix} = \begin{bmatrix} z_2 \\ z_4 \end{bmatrix} = \begin{bmatrix} -\epsilon(t) \\ 0 \end{bmatrix}$$

where $\epsilon(t) > 0$. Substituting this into the internal dynamics (52), we obtain

$$\begin{bmatrix} \dot{z}_5 \\ \dot{z}_6 \end{bmatrix} = \frac{\epsilon(t)}{2c^2bL} \begin{bmatrix} cb \sin \phi - cL \cos \phi \\ -cb \sin \phi - cL \cos \phi \end{bmatrix}$$

A solution of this internal dynamics is

$$z_5^* = -\frac{1}{r}t + c_1 \quad (55)$$

$$z_6^* = -\frac{1}{r}t + c_1 \quad (56)$$

where c_1 is a constant. That is, the two wheels rotate at exactly the same angular velocity and the mobile platform moves straight in the negative \mathbf{X}_1 direction.

We now study the stability of the internal motion described by equations (55) and (56). We first change the state variable so that the stability of the internal motion in z^2 can be formulated as the stability of equilibrium points in ζ .

$$\zeta_1 = z_5 - z_5^*$$

$$\zeta_2 = z_6 - z_6^*$$

We may express the internal dynamics in terms of $\zeta = \begin{bmatrix} \zeta_1 & \zeta_2 \end{bmatrix}^T$.

$$\dot{\zeta} = \begin{bmatrix} \dot{\zeta}_1 \\ \dot{\zeta}_2 \end{bmatrix} = \frac{\epsilon(t)}{2c^2bL} \begin{bmatrix} cb \sin(c\zeta_1 - c\zeta_2) - cL \cos(c\zeta_1 - c\zeta_2) + \frac{1}{r} \\ -cb \sin(c\zeta_1 - c\zeta_2) - cL \cos(c\zeta_1 - c\zeta_2) + \frac{1}{r} \end{bmatrix}$$

This system has an equilibrium subspace characterized by

$$E_\zeta = \{\zeta \mid \zeta_1 = \zeta_2\}$$

We may not draw any conclusion based on the linear approximation of the internal dynamics which has an eigenvalue at the origin. We will utilize the Liapunov method to establish the stability condition. Consider the following candidate for a Liapunov function

$$V(\zeta) = 1 - \cos(c\zeta_1 - c\zeta_2)$$

In a neighborhood of E_ζ , $V(\zeta) = 0$ if $\zeta \in E_\zeta$, and $V(\zeta) > 0$ if $\zeta \notin E_\zeta$. Thus $V(\zeta)$ is positive definite with respect to E_ζ , and may serve as a Liapunov function for testing the stability of E_ζ . We compute the derivative of $V(\zeta)$ with respect to the time

$$\dot{V}(\zeta) = \frac{\partial V}{\partial \zeta} \dot{\zeta} = \frac{\epsilon(t)}{L} \sin^2(c\zeta_1 - c\zeta_2)$$

Since $\epsilon(t) > 0$, $\dot{V}(\zeta)$ is also positive definite with respect to E_ζ . Therefore the equilibrium subspace E_ζ is not stable.

On the other hand, if the reference point is controlled to move in the positive \mathbf{X}_1 direction, the velocity of the reference point is

$$\begin{bmatrix} \dot{y}_1 \\ \dot{y}_2 \end{bmatrix} = \begin{bmatrix} \dot{z}_2 \\ \dot{z}_4 \end{bmatrix} = \begin{bmatrix} \epsilon(t) \\ 0 \end{bmatrix}$$

where $\epsilon(t) > 0$. Using the same Liapunov function, we can similarly show that

$$\dot{V}(\zeta) = -\frac{\epsilon(t)}{L} \sin^2(c\zeta_1 - c\zeta_2)$$

along the forward internal motion. Therefore, the forward internal motion is stable. Intuitively, if the mobile platform is “pushed” at the reference point, the internal motion is not stable. If it is “pulled” or “dragged” at the reference point, the internal motion is stable.

5 Conclusion

We presented a number of interesting results on the feedback linearization of the dynamic system of a wheeled mobile robot. The first result reveals that the system is not input-state linearizable. The proof of this result is based on the fact a wheeled mobile robot is nonholonomically constrained. The other results are on the input-output linearization and decoupling of the system. Two types of outputs have been addressed. In the first type of output, the center point of the mobile robot on the wheel axis is intended to be controlled. It has been known that the point on the wheel axis cannot be controlled using a *static* feedback [14, 15]. We show that the center point can be controlled to track a trajectory by using a *dynamic* nonlinear feedback. The dynamic feedback for achieving the input-output linearization and decoupling has been developed through a three-step algorithm. The second output takes the coordinates of a reference point in front of the mobile robot. The input-output linearization of the system under this output is possible by simply using a static nonlinear feedback. The last part of the paper investigates the behavior of the internal dynamics of the system with the second type of output. We showed that the internal motion of the system is asymptotically stable when the reference point is controlled to move forward, but is unstable when it is controlled to move backward. These results, together with the results on controllability and feedback stabilization [18, 20, 14, 15, 16] provide a theoretical foundation for feedback control of wheeled mobile robots.

References

- [1] R. W. Brockett. Feedback invariants for nonlinear systems. In *Preprints of 6th CIFAC Congress*, pages 1115–1120, Helsinki, 1978.
- [2] R. Su. On the linear equivalents of nonlinear systems. *Systems and Control Letters*, 2:48–52, 1982.
- [3] B. Jakubczyk and W. Respondek. On linearization of control systems. *Bulletin Academy Polonaise Science, Ser. Science Mathematics*, 28:517–522, 1980.
- [4] L. R. Hunt, R. Su, and G. Meyer. Design of multi-input nonlinear systems. In R. S. Millman R. Brockett and H. Sussmann, editors, *Differential Geometric Control Theory*, pages 268–298, Boston, Mass., 1983.
- [5] A. Isidori and A. Ruberti. On the synthesis of linear input output responses for nonlinear systems. *Systems and Control Letters*, 4(1):17–22, 1984.
- [6] A. Isidori. *Nonlinear Control Systems: An Introduction*. Springer-Verlag, Berlin, New York, 1985.
- [7] H. Nijmeijer and A. J. van der Schaft. *Nonlinear Dynamic Control Systems*. Springer-Verlag, New York, 1990.

- [8] J. W. Grizzle, M. D. Di Benedetto, and C. H. Moog. Computing the differential output rank of a nonlinear system. In *Proceedings of 26th IEEE Conference on Decision and Control*, pages 142–145, Los Angeles, CA, December 1987.
- [9] J. P. Laumond. Finding collision-free smooth trajectories for a non-holonomic mobile robot. In *10th International Joint Conference on Artificial Intelligence*, pages 1120–1123, Milano, Italy, 1987.
- [10] Z. Li and J. F. Canny. *Robot Motion Planning with Nonholonomic Constraints*. Technical Report Memo UCB/ERL M89/13, Electronics Research Laboratory, University of California, Berkeley, CA, February 1989.
- [11] J. Barraquand and Jean-Claude Latombe. On nonholonomic mobile robots and optimal maneuvering. In *Proceedings of Fourth IEEE International Symposium on Intelligent Control*, Albany, NY, September 1989.
- [12] Jean-Claude Latombe. *Robot Motion Planning*. Kluwer Academic Publishers, Boston, MA, 1991.
- [13] G. Lafferriere and H. Sussmann. Motion planning for controllable systems without drift. In *Proceedings of 1991 International Conference on Robotics and Automation*, pages 1148–1153, Sacramento, CA, April 1991.
- [14] B. d’Andrea-Novet, G. Bastin, and G. Campion. Modelling and control of non holonomic wheeled mobile robots. In *Proceedings of 1991 International Conference on Robotics and Automation*, pages 1130–1135, Sacramento, CA, April 1991.
- [15] C. Samson and K. Ait-Abderrahim. Feedback control of a nonholonomic wheeled cart in cartesian space. In *Proceedings of 1991 International Conference on Robotics and Automation*, pages 1136–1141, Sacramento, CA, April 1991.
- [16] C. Canudas de Wit and R. Roskam. Path following of a 2-DOF wheeled mobile robot under path and input torque constraints. In *Proceedings of 1991 International Conference on Robotics and Automation*, pages 1142–1147, Sacramento, CA, April 1991.
- [17] B. d’Andrea-Novet, B. Bastin, and G. Campion. Dynamic feedback linearization of nonholonomic wheeled mobile robots. In *Proceedings of 1992 International Conference on Robotics and Automation*, pages 2527–2532, Nice, France, May 1992.
- [18] Anthony Bloch and N. H. McClamroch. Control of mechanical systems with classical nonholonomic constraints. In *Proceedings of 28th IEEE Conference on Decision and Control*, pages 201–205, Tampa, Florida, December 1989.
- [19] G. Walsh, D. Tilbury, S. Sastry, R. Murray, and J.P. Laumond. Stabilization of trajectories for systems with nonholonomic constraints. In *Proceedings of 1992 International Conference on Robotics and Automation*, pages 1999–2004, Nice, France, May 1992.

- [20] Anthony Bloch, N. H. McClamroch, and M. Reyhanoglu. Controllability and stability properties of a nonholonomic control system. In *Proceedings of 29th IEEE Conference on Decision and Control*, pages 1312–1314, Honolulu, Hawaii, December 1990.
- [21] G. Campion, B. d’Andrea-Novell, and G. Bastin. Controllability and state feedback stabilization of non holonomic mechanical systems. In C. Canudas de Wit, editor, *Lecture Notes in Control and Information Science*, pages 106–24, Springer-Verlag, 1991.
- [22] William M. Boothby. *An Introduction to Differentiable Manifolds and Riemannian Geometry*. Academic Press, 1975.
- [23] Reinhardt M. Rosenberg. *Analytical Dynamics of Discrete Systems*. Plenum Press, New York, 1977.
- [24] J. Descusse and C. H. Moog. Decoupling with dynamic compensation for strong invertible affine nonlinear systems. *International Journal of Control*, 42(6):1387–1398, 1985.
- [25] A. Isidori. Control of nonlinear systems via dynamic state-feedback. In M. Fliess and M. Hazewinkel, editors, *Algebraic and Geometric Methods in Nonlinear Control Theory*, pages 121–145, D. Reidel Publishing Company, Dordrecht, Holland, 1986.
- [26] H. Nijmeijer and W. Respondek. Dynamic input-output decoupling of nonlinear control systems. *IEEE Transactions on Automatic Control*, 33(11):1065–1070, November 1988.
- [27] J. Descusse and C. H. Moog. Dynamic decoupling for right-invertible nonlinear systems. *Systems and Control Letters*, 8:345–348, 1987.
- [28] M. Fliess. A note on the invertibility of nonlinear input-output differential systems. *Systems and Control Letters*, 8:147–151, 1986.
- [29] M. Fliess. Some remarks on nonlinear invertibility and dynamic state-feedback. In C. I. Byrnes and A. Lindquist, editors, *Theory and Applications of Nonlinear Control Systems*, pages 115–121, Elsevier Science Publishers, New York, NY, 1986.
- [30] C. H. Moog. Note on the left-invertibility of nonlinear systems. In C. I. Byrnes, C. F. Martin, and R. E. Saeks, editors, *Analysis and Control of Nonlinear Systems*, pages 469–475, Elsevier Science Publishers, New York, NY, 1988.
- [31] Jean-Jacques E. Slotine and Weiping Li. *Applied Nonlinear Control*. Prentice Hall, Inc., Englewood Cliffs, New Jersey, 1991.