

Spring 5-31-1999

On-line state and parameter estimation in nonlinear systems

David A. Haessig
New Jersey Institute of Technology

Follow this and additional works at: <https://digitalcommons.njit.edu/dissertations>



Part of the [Electrical and Electronics Commons](#)

Recommended Citation

Haessig, David A., "On-line state and parameter estimation in nonlinear systems" (1999). *Dissertations*. 983.

<https://digitalcommons.njit.edu/dissertations/983>

This Dissertation is brought to you for free and open access by the Electronic Theses and Dissertations at Digital Commons @ NJIT. It has been accepted for inclusion in Dissertations by an authorized administrator of Digital Commons @ NJIT. For more information, please contact digitalcommons@njit.edu.

Copyright Warning & Restrictions

The copyright law of the United States (Title 17, United States Code) governs the making of photocopies or other reproductions of copyrighted material.

Under certain conditions specified in the law, libraries and archives are authorized to furnish a photocopy or other reproduction. One of these specified conditions is that the photocopy or reproduction is not to be “used for any purpose other than private study, scholarship, or research.” If a user makes a request for, or later uses, a photocopy or reproduction for purposes in excess of “fair use” that user may be liable for copyright infringement,

This institution reserves the right to refuse to accept a copying order if, in its judgment, fulfillment of the order would involve violation of copyright law.

Please Note: The author retains the copyright while the New Jersey Institute of Technology reserves the right to distribute this thesis or dissertation

Printing note: If you do not wish to print this page, then select “Pages from: first page # to: last page #” on the print dialog screen

The Van Houten library has removed some of the personal information and all signatures from the approval page and biographical sketches of theses and dissertations in order to protect the identity of NJIT graduates and faculty.

ABSTRACT

ON-LINE STATE AND PARAMETER ESTIMATION IN NONLINEAR SYSTEMS

by
David A. Haessig

On-line, simultaneous state and parameters estimation in deterministic, nonlinear dynamic systems of known structure is the problem considered. Available methods are few and fall short of user needs in that they are difficult to apply, their applicability is restricted to limited classes of systems, and for some, conditions guaranteeing their convergence don't exist.

The new methods developed herein are placed into two categories: those that involve the use of Riccati equations, and those that do not. Two of the new methods do not use Riccati equations, and each is considered to be a different extension of Friedland's parameter observer for nonlinear systems with full state availability to the case of partial state availability. One is essentially a reduced-order variant of a state and parameter estimator developed by Raghavan. The other is developed by the direct extension of Friedland's parameter observer to the case of partial state availability. Both are shown to be globally asymptotically stable for nonlinear systems affine in the unknown parameters and involving nonlinearities that depend on known quantities, a class restriction also true of existing state and parameter estimation methods. The two new methods offer, however, the advantages of improved computational efficiency and the potential for superior transient performance, which is demonstrated in a simulation example.

Of the new methods that do involve a Riccati equation, there are three. The first is the separate-bias form of the reduced-order Kalman filter. The scope of this filter is somewhat broader than the others developed herein in that it is an **optimal** filter for

linear, stochastic systems involving noise-free observations. To apply this filter to the joint state and parameter estimation problem, one interprets the unknown parameters as constant biases. For the system class defined above, the method is globally asymptotically stable.

The second Riccati equation based method is derived by the application of an existing method, the State Dependent **Algebraic** Riccati Equation (SDARE) filtering method, to the problem of state and parameter estimation. It is shown to work well in several nonlinear examples involving a few unknown parameters; however, as the number of parameters increases, the method's applicability is diminished due to an apparent loss of observability within the filter which hinders the generation of filter gains.

The third is a new filtering method which uses a State Dependent **Differential** Riccati Equation (SDDRE) for the generation of filter gains, and through its use, avoids the "observability" shortcomings of the SDARE method. This filter is similar to the Extended Kalman Filter (EKF), and is compared to the EKF with regard to stability through a Lyapunov analysis, and with regard to performance in a 4th order stepper motor simulation involving 5 unknown parameters. For the very broad class of systems that are bilinear in the state and unknown parameters, and potentially involving products of unmeasured states and unknown parameters, the EKF is shown to possess a semi-global region of asymptotic stability, given the assumption of observability and controllability along estimated trajectories. The stability of the new SDDRE filter is discussed.

**ON-LINE STATE AND PARAMETER ESTIMATION
IN NONLINEAR SYSTEMS**

**by
David A. Haessig**

**A Dissertation
Submitted to the Faculty of
New Jersey Institute of Technology
in Partial Fulfillment of the Requirements for the Degree of
Doctor of Philosophy**

Department of Electrical and Computer Engineering

May 1999

Copyright © 1999 by David A. Haessig

ALL RIGHTS RESERVED

APPROVAL PAGE

**ON-LINE STATE AND PARAMETER ESTIMATION
IN NONLINEAR SYSTEMS**

David A. Haessig

Dr. Bernard Friedland, Dissertation Adviser Date
Distinguished Professor of Electrical Engineering, NJIT

Dr. Andrew Meyer, Committee Member Date
Professor of Electrical Engineering, NJIT

Dr. Timothy Chang, Committee Member Date
Associate Professor of Electrical Engineering, NJIT

Denis Blackmore, Committee Member Date
Professor of Mathematics, NJIT

Dr. David Cooper Date
Member of Technical Staff, *GEC*-Marconi Hazeltine, CNI Division
Wayne, New Jersey

BIOGRAPHICAL SKETCH

Author: David A. Haessig
Degree: Doctor of Philosophy
Date: May 1999

Undergraduate and Graduate Education:

- Doctor of Philosophy in Electrical Engineering,
New Jersey Institute of Technology, Newark, NJ, 1999
- Master of Science in Mechanical Engineering
Lehigh University, Bethlehem, PA, 1981
- Bachelor of Science in Mechanical Engineering
Lehigh University, Bethlehem, PA, 1979

Major: Electrical Engineering

List of Publications:

David Haessig and Bernard Friedland, "Separate-Bias Estimation with Reduced-Order Kalman Filters", *IEEE Trans. Auto. Cntrl*, vol. 43, no. 7, pp. 983-986, July 1998.

David Haessig, "A Method of State and Parameter Estimation in Nonlinear Systems," *Proc. Amer. Contr. Conf.*, Albuquerque, NM, June 1997, pp. 947-951.

David Haessig, "Line-of-Sight Pointing and Stabilization Control System", *The Controls Handbook*, Boca Raton, FL, CRC Press, Feb. 1996.

David Haessig, "Modern Control Solution to a Precision Pointing System Stability Problem", *Proc. Amer. Contr. Conf.*, Seattle, WA, June 1995.

David Haessig, "Selection of LQG/LTR Weighting Matrices through Constrained Optimization", *Proc. Amer. Contr. Conf.*, Seattle, WA, June 1995.

List of Publications (cont.):

David Haessig and Marv Silver, "An Integrated Pointing / Stabilization and GPS Inertial Navigation System (PSGINS)", *Joint Serv. Data Exch. for Guid., Nav., Contr.*, Scottsdale, AZ, Nov. 1994.

David Haessig and Marv Silver, "An Integrated High Accuracy Antenna Pointing/Stabilization and GPS/Inertial Navigation System (PSGINS)", *The Inst. of Nav. 50th Annual Meeting*, Col. Sp., CO, June 1994.

David Haessig, "Image Stabilization Control System", *IEEE Reg. Conf. Contr. Sys.*, NJIT, Newark, NJ, Aug. 1993.

David Haessig and Bernard Friedland, "On the Modeling and Simulation of Friction", *ASME J. Dyn. Meas., Contr.*, vol. 113, pp. 354-362, Sept. 1991.

David Haessig, "Modern Control Methods Applied to a Line-of-Sight Stabilization and Tracking System", *Proc. Amer. Contr. Conf.*, Minn., MN, June 1987, pp.1491-1498.

Jack Richman, Bernard Friedland, and David Haessig, "Integrated Strapdown Guidance and Control for Precision Guided Missiles", *IEEE Contr. Sys. Mag.*, June 1986.

Jack Richman, Bernard Friedland, and David Haessig, "Integrated Strapdown Avionics for Precision Guided Weapons", *Proc. Amer. Contr. Conf.*, Boston, MA, June 1985.

David Haessig and Bernard Friedland, "Maximum-Likelihood Estimation of Target Acceleration," *23rd Conf. on Decision and Contr.*, Las Vegas, NV, Dec. 1984, pp.1898-1402.

List of Patents:

"Two-Axis Mirror Stabilization Assembly," (with C. Fuchs, et. al.), U.S. Patent 4 881 800, 1989.

"Mirror Positioning Assembly for Stabilizing the Line-of-Sight in a Two-Axis Line-of-Sight Pointing System", U.S. Patent 5 220 456, 1993.

"Image Stabilization Assembly for an Optical System", U.S. Patent 5 307 206, 1994.

"Two-Axis Satellite Antenna Mounting and Tracking Assembly", U.S. Patent pending, Docket no. 01KE96139.

This work is dedicated to my wife, Kathleen,
and children, Ryan and Meagan.

ACKNOWLEDGMENT

As in most everyone's life, we all have people around us who help us to grow, some more than others. I have been blessed with a great number of terrific people. My parents created a warm and secure home in which to grow up, encouraged me to work hard and do well, and helped me to achieve a high level of self confidence. My wife has been a constant supporter and cheerleader. My grandmother has told me countless times throughout my life and even today, that I had done a good job on this or that. Without their input throughout my life, I would not have been prepared to accomplish the work that has lead to this thesis. A great deal of credit goes to them.

Special thanks go to Dr. Bernard Friedland, who has had a significant positive impact on my career. I have great respect for him and his work, and over the years worked hard to achieve his approval. During the past five years his guidance of my dissertation effort was outstanding. On numerous times his observations and insights caused my efforts to move in a direction that lead to an important result which would have been missed otherwise. Earlier, while working for him during my 10 years at Kearfott, he created an environment in the group that he managed within which I thrived. There was great interaction between all members of the department, and it was exciting as we were working at the forefront of real control system applications. I learned a great deal about control system design during that time.

I am also very much indebted to GEC-Marconi Hazeltine for providing me with the opportunity to pursue an advanced degree, covering the educational expenses completely, and allowing me to work part time for three years in order to concentrate on this dissertation effort.

TABLE OF CONTENTS

Chapter	Page
1 INTRODUCTION.....	1
1.1 Motivation.....	3
1.2 Problem Definition and System Class.....	4
1.3 Overview of Existing Methods.....	6
1.4 Research Objectives.....	10
1.5 Contributions of Thesis.....	10
2 BACKGROUND.....	14
2.1 Stability.....	14
2.1.1 Lyapunov Stability.....	16
2.1.2 Stability of $\dot{e} = -L(t)e$ when $L(t) = L'(t) > 0$	18
2.1.3 Observability.....	20
2.2 Separate-Bias Kalman filter.....	21
2.3 Reduced-Order Kalman filter.....	25
2.4 State Dependent Algebraic Riccati Equation Filter.....	26
3 EXISTING METHODS, AN OVERVIEW.....	29
3.1 Parameter Estimation.....	29
3.1.1 Standard Linear Theory.....	29
3.1.2 Narendra and Kudva's Method.....	33
3.1.3 Friedland's Parameter Estimator.....	35
3.2 State and Parameter Estimation.....	36
3.2.1 Standard Linear Theory.....	37
3.2.2 Narendra and Annaswamy's Method.....	39

TABLE OF CONTENTS
(Continued)

Chapter	Page
3.2.3 Bastin and Gevers' Method	40
3.2.4 Raghavan's Method	41
4 NEW METHODS	44
4.1 Nonlinear Reduced-Order Observer 1	44
4.1.1 System Class	45
4.1.2 Observer Equations	45
4.1.3 Error Dynamics and Stability	48
4.2 Nonlinear Reduced-Order Observer 2	50
4.2.1 Background	51
4.2.2 General Observer Equations.....	52
4.2.3 Error Dynamics for Systems Involving x_2 and θ	54
4.2.4 Error Dynamics for System Class A	55
4.2.5 Comparison of the Non-Riccati Equation Based Methods	62
4.3 Separate-Bias Reduced-Order Kalman Filter.....	63
4.3.1 System Class	64
4.3.2 Filter Equations	65
4.3.3 Application to State and Parameter Estimation.....	76
4.4 SDARE State and Parameter Observer	76
4.4.1 Filter Equations	77
4.4.2 Examples	79
4.4.3 Discussion	84

TABLE OF CONTENTS
(Continued)

Chapter	Page
4.5 A.New Nonlinear Filter	85
4.5.1 Filtering Equations	86
4.5.2 Local Stability	88
4.5.3 Application to Bilinear Dynamic Systems	89
4.5.4 Stability Background	91
4.5.5 Stability with Bilinear Dynamic Systems	97
5 EXAMPLES	108
5.1 Comparison of all Methods in a Simple Example.....	108
5.1.1 Full-order Kalman Filter	109
5.1.2 Reduced-Order Kalman Filter	111
5.1.3 Narendra and Annaswamy's Observer	113
5.1.4 Bastion and Gevers' Observer	114
5.1.5 Raghavan's Observer	116
5.1.6 Reduced-Order Separate-Bias Kalman Filter.....	117
5.1.7 Nonlinear Observer 1	119
5.1.8 Nonlinear Observer 2	121
5.1.8 Summary of Results and Discussion	122
5.2 Stepper Motor Example	123
5.2.1 Model	124
5.2.2 Filter Equations	127
5.2.3 Simulation Results.....	128

TABLE OF CONTENTS
(Continued)

Chapter	Page
6 CONCLUSIONS AND RECOMMENDED FUTURE WORK	136
REFERENCES	141

LIST OF TABLES

Table	Page
1.1 Existing Methods for Simultaneous State and Parameter Estimation	8
1.2 New Methods for Simultaneous State and Parameter Estimation	13
5.1 Summary of Results, All methods in a Simple Example.....	123
5.2 State Variable and Input Definitions.....	125
5.3 System Parameter Definitions.....	125
5.3 Stepper Motor Parameter Values	127

LIST OF FIGURES

Figure	Page
1.1 Indirect Adaptive Control Showing Simultaneous State And Parameter Estimation On Left.....	4
2.1 Separate-Bias Full-order Kalman filter.....	22
4.1 Simulation of Nonlinear Observer 2 in Simple 2nd Order Example.....	60
4.2 Simulation of Nonlinear Observer 2 in 3 rd Order Example	63
4.3 Separate-Bias Reduced-Order Kalman Filter	66
4.4 Performance of the SDARE Filter, Friction Estimation And Compensation Example	81
4.5 State Estimation Error, Damped Harmonic Oscillator.....	83
4.6 Parameter Estimation Error, Damped Harmonic Oscillator	84
5.1 Full-Order Kalman Filter	110
5.2 Reduced-Order Kalman Filter.....	112
5.3 Narendra and Annaswamy's Adaptive Observer	113
5.4 Bastion and Gever's Adaptive Observer	115
5.5 Raghavan's Adaptive Observer	117
5.6 Reduced-Order Separate Bias Kalman Filter.....	119
5.7 Nonlinear Observer 1	121
5.8 Parameter Estimates, Stepper Motor, SDDRE (solid) EKF (dotted), Coulomb Friction Known to be Zero.....	129
5.9 Parameter Estimates, Stepper Motor, SDDRE (solid) EKF (dotted), Coulomb Friction Known to be Zero.....	130
5.10 Parameter Estimates, Stepper Motor, SDDRE (solid) EKF (dotted), Coulomb Friction Known to be Zero.....	130
5.11 State Estimates, Stepper Motor, SDDRE (solid) EKF (dotted), Coulomb Friction Known to be Zero.....	131

LIST OF FIGURES
(Continued)

Figure	Page
5.12 State Estimates, Stepper Motor, SDDRE (solid) EKF (dotted), Coulomb Friction Known to be Zero.....	131
5.13 Parameter Estimates, Stepper Motor, SDDRE (solid) EKF (dotted), Coulomb Friction Unknown, Viscous Damping Zero	133
5.14 Parameter Estimates, Stepper Motor, SDDRE (solid) EKF (dotted), Coulomb Friction Unknown, Viscous Damping Zero	133
5.15 Parameter Estimates, Stepper Motor, SDDRE (solid) EKF (dotted), Coulomb Friction Unknown, Viscous Damping Zero	134
5.16 State Estimates, Stepper Motor, SDDRE (solid) EKF (dotted), Coulomb Friction Unknown, Viscous Damping Zero	134
5.17 State Estimates, Stepper Motor, SDDRE (solid) EKF (dotted), Coulomb Friction Unknown, Viscous Damping Zero	135

CHAPTER 1

INTRODUCTION

In the study of control system design theory, particularly classical control theory, it is typically assumed that the designer has perfect knowledge of the system to be controlled. Not only does the designer know the system structure, i.e. the exact dynamic equations governing the evolution of the controlled state, but he or she also knows the system parameters precisely. This, however, is generally not true. In most physical systems, the characteristics of the system change for various reasons: parameters (e.g. friction) may change with temperature or over the life of the unit, rapid shifts in system dynamics can occur due to a catastrophic change of some sort, resonant frequencies can shift, and so on. As a result, a design that is stable and effective at one condition can become unstable and ineffective at another. This is also true of much of the modern control methods developed since the 1960's¹. Thus, many of the powerful classical and modern design techniques that assume knowledge of the dynamic model can become ineffective in the face of parameter uncertainty. Parameter estimation techniques provide a way to address this problem.

On-line parameter estimation techniques attempt to extract, in real time, parameter information from a dynamic system providing full-state availability, i.e. all of the state variables are measured with sufficient accuracy so that state estimation is not required. The best estimate of system parameters can then be used in a parameter dependent

¹ A great deal of effort since the early 80's, however, has been directed at the design of stable controllers for systems with quantifiable uncertainty.

controller to adapt to parameter changes. In many applications, however, the entire state of the underlying dynamic system is not measured directly, and as a result it is necessary to estimate the unmeasured state variables as well as the unknown parameters. In comparison to the problem of parameter estimation alone, this is a significantly more difficult problem because it is inherently nonlinear. Even the simplest expression involving an unknown parameter θ and an unknown state variable x , their product θx , is nonlinear. Suitable techniques have therefore been slow in coming.

Nevertheless, a wide range of technologies exist that could benefit by the availability of stable state and parameters estimation methods. Applications can be noted in the literature in the areas of electronic systems, communication systems, guidance and navigation systems, chemical systems, mechanical and robotic systems, biomedical systems, financial systems, etc. Consider the following example which appeared in a Special Issue on Medicine in the *IEEE Transactions on Automatic Control* [44]. The application is a ventricular assist device that works with an impaired heart to meet the cardiovascular demands of the patient. A dynamic model of blood flow through the heart is used to enable the implementation of an effective control strategy. The dynamic model presented,

$$\dot{f} = -\theta_2 f - \theta_1 (p_S - p_A) \quad (\text{flow}) \quad (1.1)$$

$$\dot{p}_S = \theta_3 f - \theta_4 (p_S - p_R) \quad (\text{peripheral pressure}) \quad (1.2)$$

$$\dot{p}_R = \theta_5 (p_S - p_R) \quad (\text{left arterial pressure}) \quad (1.3)$$

involves three states and 5 uncertain hemodynamic parameters. (The variable p_A is an input.) Two of the states, f and p_R , can be measured, the other p_S cannot and both

measurements include noise. Thus, this problem involves uncertain parameters multiplying unmeasured state variables that require estimation. In [44] the authors employ an Extended Kalman Filter (EKF) to estimate quite effectively both the state and parameter vectors, online. There is, however, no known guarantee of stability with the EKF, which can be a cause of concern in some cases, especially in this one where a patient's health could be affected. A filter similar in complexity that possesses a property of asymptotic stability would therefore be greatly advantageous. The stability of the EKF and of the new filter with bilinear systems of this type is examined herein, and a proof of stability for the EKF is given. A simulation example of a similar system, a 4th order stepper motor with 5 unknown parameters, is examined in Chapter 5.

1.1 Motivation

Perhaps the most important general application of the type of method developed in this thesis is that of the adaptive controller. In a controller designed using the Indirect approach, the control law explicitly contains an "Estimation" section and a "Control" section (see Figure 1.1). The "Estimation" section performs the simultaneous estimation of the unknown parameters θ and the state x . The "Control" section (to the right of the line) then use these estimates as if they were true. Thus, both the "Controller Design" and "Controller" blocks contain algorithms designed under the assumption that the state and parameter vectors are known. (This idea is referred to as the "Certainty Equivalence Principle" [2] .) As a result, the Estimation and Control sections of an Indirect Adaptive Controller can be defined independently, and then these separate parts can be brought

together to create the complete adaptive control law. The estimation methods developed in the present work can be applied in this type of adaptive control system design.

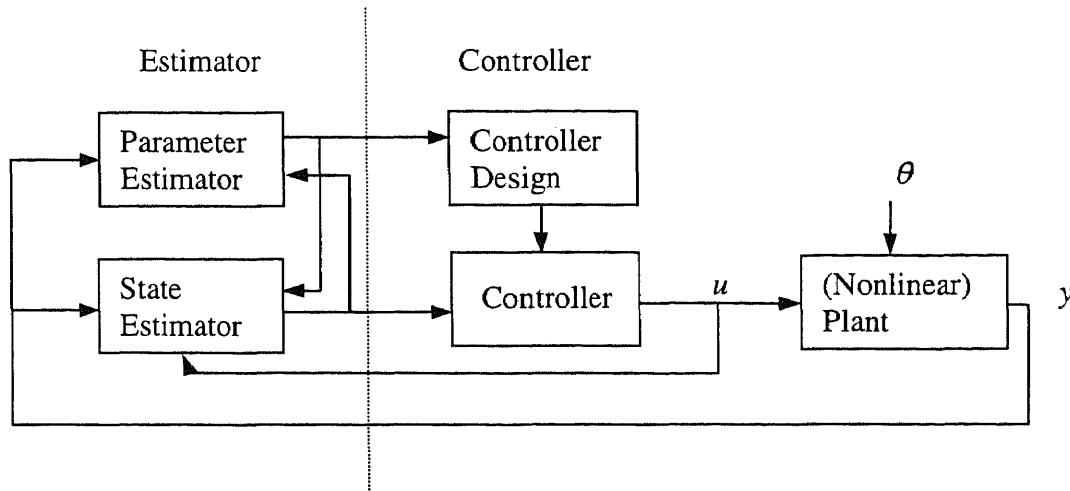

Figure 1.1 Indirect Adaptive Control Showing Simultaneous State And Parameter Estimation On Left

1.2 Problem Definition and System Class

This section introduces the notation necessary for the mathematical definition of the problem to be addressed, and it gives a precise statement of the classes of systems to be considered. In all cases it is assumed that the structure of the system is known, and that a mathematical model of the actual system under study is available. What is unknown are the initial state of the system and specific parameter values.

An uncertain nonlinear continuous-time dynamic system in most general form can be represented:

$$\begin{aligned}\dot{x}(t) &= f(x(t), u(t), \theta(t), t) + w(t) \\ y(t) &= h(x(t), u(t), \theta(t), t) + v(t)\end{aligned}\tag{1.4}$$

where $f()$ and $h()$ are nonlinear functions,

$$f : \mathfrak{R}^n \times \mathfrak{R}^r \times \mathfrak{R}^p \times \mathfrak{R}^+ \rightarrow \mathfrak{R}^n$$

$$h : \mathfrak{R}^n \times \mathfrak{R}^r \times \mathfrak{R}^p \times \mathfrak{R}^+ \rightarrow \mathfrak{R}^m$$

where $w(t)$ and $v(t)$ are zero mean gaussian noise processes of proper dimension, and

where

$$x(t) := [x_1(t), \dots, x_n(t)] \in \mathfrak{R}^n$$

$$\theta(t) := [\theta_1(t), \dots, \theta_p(t)] \in \mathfrak{R}^p$$

$$u(t) := [u_1(t), \dots, u_r(t)] \in \mathfrak{R}^r$$

$$y(t) := [y_1(t), \dots, y_m(t)] \in \mathfrak{R}^m$$

$$t \in \mathfrak{R}^+$$

are the state, unknown parameters, known input, and measurement vectors, respectively; t is time. This general nonlinear structure is considered by most investigators to be too general for the development of systematic analysis and synthesis techniques. Therefore, we define the following three restricted system classes, all involving uncertain parameters, and use these definitions to clearly identify the contribution that has been made by each of the new methods developed in the present work. They will be called System Class A, B, and C, and will be ranked in order of increasing generality. In other words, System Class B includes System Class A but not System Class C.

System Class B: System Class B is given by:

$$\begin{aligned} \dot{x}(t) &= A(t)x(t) + B(t)u(t) + E(t)\mathcal{G}(t) \\ y(t) &= C(t)x(t) \end{aligned} \tag{1.5}$$

Measurement and process noise are assumed to be zero. The matrices $A(t)$, $B(t)$, $E(t)$ and $C(t)$ may be time-varying, but are known. Also, it should be recognized that $E(t)$, a known matrix function of time, can contain nonlinear functions that depend on known

quantities $y(t)$ and $u(t)$; i.e. $E(t) = E(u(t), y(t), t)$. Thus, System Class B can also encompass nonlinear systems represented as:

$$\begin{aligned}\dot{x}(t) &= A(t)x(t) + B(t)u(t) + E(t, y, u, \theta(t))\theta(t) + g(t, y, u) \\ y(t) &= C(t)x(t)\end{aligned}\tag{1.6}$$

Furthermore, the same can also be true of matrices $A(t)$, $B(t)$ and $C(t)$.

When working with reduced-order observers, it is convenient to arrange the state variables of (1.6) into two groups, the first m that are directly measured and the remaining $n-m$ that are unmeasured. This may require a linear state transformation to eliminate $C(t)$ in the measurement equation. System B can then be represented using the following partitioned state equations:

$$\begin{aligned}\dot{x}_1(t) &= A_{11}(t)x_1(t) + A_{12}(t)x_2(t) + B_1(t)u(t) + E_1(t, y, u)\theta(t) + g_1(t, y, u) \\ \dot{x}_2(t) &= A_{21}(t)x_1(t) + A_{22}(t)x_2(t) + B_2(t)u(t) + E_2(t, y, u)\theta(t) + g_2(t, y, u) \\ y(t) &= x_1(t)\end{aligned}\tag{1.7}$$

System Class A: System Class A shall be identical to System Class B, equation (1.7), with the exception that submatrices A_{12} and A_{22} shall be constant rather than functions of time.

System Class C: System Class C shall be similar to Class B with an important exception, the nonlinear matrix $E()$ shall be allowed to depend on the entire state, and the unmeasured elements of x that appear in $E()$ shall appear linearly, such that $E()\theta$ is bilinear in the unmeasured states and unknown parameters:

$$\begin{aligned}\dot{x}(t) &= A(t)x(t) + B(t)u(t) + E(t, x, u)\theta(t) + g(t, y, u) \\ y(t) &= C(t)x(t)\end{aligned}\tag{1.8}$$

1.3 Overview of Existing Methods

One might expect that any of the available techniques for estimating the state of a nonlinear process could potentially be applied to the problem of state and parameter estimation. Surveys of existing continuous-time nonlinear observation methods are found in [30] and [42]. In general, however, the joint state and parameter estimation problem falls outside the scope of most nonlinear observation techniques. The difficulty most often involves the poles at the origin contributed by parameter states. To illustrate this, we consider the following nonlinear system,

$$\begin{aligned}\dot{x} &= Ax + g(y, u, t) + f(x, u, t) \\ y &= Cx\end{aligned}$$

which will involve a nonlinearity $f(x, \cdot, \cdot)$ that is globally Lipschitz in x with a Lipschitz constant γ , i.e., $|f(x, u, t) - f(\hat{x}, u, t)| < \gamma|x - \hat{x}|$ for all $u \in \mathfrak{R}^m, t \in \mathfrak{R}$. For this system, Raghavan [36] proposes the observer:

$$\dot{\hat{x}} = A\hat{x} + g(y, u, t) + f(\hat{x}, u, t) + L(y - C\hat{x})$$

with the observer gain $L = PC' / 2\varepsilon$, requiring the solution of the Algebraic Riccati Equation (ARE)

$$AP + PA' + P(\gamma^2 I - \frac{1}{\varepsilon} C' C)P + I + \varepsilon I = 0$$

for some small scalar ε , to be determined such that the above is solvable. However, it will not be possible to solve this ARE unless the matrix A is Hurwitz. With parameter estimation, this requirement is violated because of the pole contributed at the origin by each unknown parameter. As a result, Raghavan's method fails when applied to parameter estimation. In fact, most nonlinear observations techniques when applied to the joint state and parameter estimation problem, encounter the same difficulty. Those

that can be applied successfully to this problem have most likely been identified as such in the literature. (Note that the Raghavan observer described in Chapter 3 is another method developed specifically for state and parameter estimation.)

Most of the contributions made to the body of theory that specifically address the joint state and parameter estimation problem have involved System Class B, i.e. nonlinear systems representable with time-varying linear models. These methods are listed below in Table 1.1 and will be discussed in some detail in Section 3.2. They include the full-order Kalman filter, the Bastin and Gevers filter, the Narandra and Annaswamy filter, and the Raghavan filter. As you will note, these methods apply only to System Class B, with two applicable only to single-input single-output systems.

Table 1.1 – Existing Methods for Simultaneous State and Parameter Estimation

Method Name	System Class	Filter Order	Comment
Kalman Filter (full-order)	B	$\frac{n+p}{2}(n+p+3)$	Applicable to MIMO systems, easy to implement, good design weights sometimes elusive
Bastin & Gevers	B	$n^2 + p$	SISO systems only
Narandra & Annaswamy	A	$2n - 1 + p$	SISO only; lowest order, cumbersome transformation required
Raghavan	A	$np + n + p$	MIMO system, application of method straightforward

The problem of simultaneous state and parameter estimation in **linear** systems was solved with the advent of the Kalman filter, although this fact was not initially recognized. Friedland demonstrates the use of the Kalman filter for parameter and state

estimation in describing its use for the calibration of an inertial system in [14]. He further clarifies the suitability of the Kalman filter for parameter estimation by his development of the Separate-bias Kalman filter in [11], where the Kalman filter is used for bias estimation, a problem that again falls into System Class B. Bias estimation is described in several other references, including an alternative derivation given in [21], and also later for time-varying bias in [22], [20] and [1].

Another investigator, Rusnak, who has worked with the Kalman filter for parameter and state estimation, examines in [39] the conditions necessary for observability in single-input single-output (SISO) linear systems. His primary conclusion is that persistent excitation is necessary to guarantee observability and stability. He extends his analysis to multi-input multi-output systems using non-minimal realizations of the plant in [40].

A few continuous-time methods have been developed in recent years for the on-line estimation of parameters only, in nonlinear dynamic systems in which the entire state vector is available. These are the method of Narendra and Kudva [33] and the method of Friedland [17]. Both are described in detail in Section 3.1.

The problem of state and parameter estimation in nonlinear systems that include System Class C has been addressed by Caglayan, et.al. in [6], who develop the extended form of the Separate-Bias Kalman filter for nonlinear systems, i.e. the Separate-Bias Extended Kalman Filter (EKF). However, like the standard EKF, no conditions for the stability of this filter are given, and so this method is not discussed in Chapter 3.

Another continuous-time method applicable to this problem has been developed by Cho and Rajamani in [7] where an adaptive observer is provided which possesses guaranteed

converge properties for a special class of systems involving Lipschitz bounded nonlinearities. Because of the relative newness of this work, it has not been included in the descriptions given in Chapter 3.

1.4 Research Objectives

This effort has focused on the problem of simultaneous state and parameter estimation in deterministic dynamic systems of known structure. The objectives of the effort were:

- to develop methods providing improved computationally efficiency and stability over existing methods
- to develop methods which can be applied to a wider class of systems than those covered by existing methods
- to identify and prove conditions for the asymptotic stability of the new methods

1.5 Contributions of Thesis

This thesis contributes five new methods for the online joint estimation of parameters and the state variables in dynamic systems. These new methods are separated into two groups: (1) those that involve Riccati equations, and (2) those that do not. All five methods are described briefly below and are listed in Table 1.2 along with some pertinent data useful for their comparison.

(1) and (2) – Nonlinear Observers One and Two: These methods are those that do not involve Riccati equations. Both possess some similarity to Friedland's parameter estimator [17], and both extend Friedland's estimator, which assumes full state availability, to the case of partial state availability. One is a reduced-order variant of

Raghavan's full-order nonlinear state and parameter observer given in [36]. The global stability of this new method is proven for System Class B. Although it does not involve a Riccati equation, it does involve an auxiliary matrix differential equation.

Nevertheless, this new filter has been found to be easier to apply than the Riccati equation based methods in that it does not require excessive tuning to yield acceptable results. This is demonstrated in a simulation example. In addition, it offers the advantage of reduced computational loading over some existing methods, the order of the filter being reduced by the number of measured states.

The second non-Riccati based method is one that is developed by directly extending Friedland's parameter estimator [17] to the case of partial state feedback. It does not involve any type of matrix differential equation. Consequently, of the available methods, new and existing, it is the least demanding computationally. Its stability is guaranteed when applied to System Class A. The method requires that the user find nonlinear functions that have application specific jacobian matrices, and it is often difficult to find these functions, particularly as system order increases.

(3) Separate-Bias Reduced-Order Kalman Filter: The first of the three Riccati equation based techniques developed herein is this Separate-Bias Reduced-Order Kalman filter. In 1969, Friedland developed the original separate-bias Kalman filter for stochastic systems involving constant and unknown bias and non-zero measurement noise [11]. In this present work, the limiting form of the separate-bias Kalman filter for vanishing measurement noise is derived. Several key features of the reduced-order filter are worth noting. First, it is the optimal filter for the conditions defined, and as such, the global stability of this new filter is guaranteed. Secondly, it has a desirable two-stage

structure; the parameters and states are estimated in separate uncoupled stages, which permits the use of two separate parallel processors if desired or if processing power is limited. In addition, it is convenient to use, in that many physical systems possess this structure naturally. Thirdly, like the full-order Separate-bias Kalman filter, this reduced-order Separate-bias filter replaces computations involving large matrices with computations involving smaller matrices, thereby improving numerical stability and in some cases computational efficiency.

(4) SDARE State and Parameter Estimator: The State Dependent Algebraic Riccati Equation (SDARE) filtering technique is applied to the problem of state and parameter estimation and shown to work well in a number of simple examples including some from System Class C. However, it is found to be less than well suited for state and parameter estimation as the number of unknown parameters increases beyond 2 or 3. This is due to the lack of observability in the pair $[A(x), C(x)]$ that is exacerbated as the number of unknown parameters is increased.

(5) A General Nonlinear Filtering Method: A new nonlinear filtering technique that applies to general nonlinear systems is proposed. It is shown to avoid the observability shortcomings of the SDARE filtering method through the use of a State Dependent Differential Riccati Equation (SDDRE). This filter is similar to and compared to the Extended Kalman filter (EKF) herein. For bilinear systems of System Class C, the stability of both the EKF and the new filtering method are examined. The semi-global asymptotic stability of the EKF is proven under mild assumptions.

Table 1.2 – New Methods for Simultaneous State and Parameter Estimation*

Method Name	System Class	Filter Order	Comment
Nonlinear Reduced-Order Observer #1	B	$n - m + p + (n - m)p$	Application straightforward and applicability guaranteed
Nonlinear Reduced-Order Observer #2	A	$n - m + p$	Applicability not guaranteed and sometime difficult
Separate-Bias Reduced-Order Kalman Filter	B	$\frac{n - m + p}{2}(n - m + p + 3)$	Good design weights sometimes elusive
SDARE Filter	C	$\frac{n + p}{2}(n + p + 3)$	Applicable to general nonlinear systems; linear "observability" problems occur with more than a few parameters
SDDRE Filter	C	$\frac{n + p}{2}(n + p + 3)$	Applicable to general nonlinear systems; "observability" problems avoided

*(Note that all are applicable to MIMO Systems)

CHAPTER 2

BACKGROUND

This chapter contains the background material needed for the development of the new filtering methods presented in Chapter 4. A number of somewhat disconnected topics are covered. General stability and Lyapunov stability theory are covered in Sections 2.1 and 2.1.1. A stability proof for time-varying systems that possess a form of symmetry common to many filtering techniques is covered in Section 2.1.2. Observability, which is always a required condition for stability, is discussed in Section 2.1.3. Two existing filtering techniques, the Separate-bias [11] and Reduced-order Kalman filters [15], are presented in Sections 2.2 and 2.3, respectively, as background for the new filter developed in Section 4, the Separate-bias Reduced-order Kalman Filter [19]. Another fairly new method, State Dependent Algebraic Riccati Equation (SDARE) filter [32] is described in Section 2.4 and applied to the problem of state and parameter estimation in Section 4.3.

2.1 Stability

Perhaps the most important property that any filtering algorithm can possess is that of asymptotic stability. Simply put, a filter that is asymptotically stable works. If conditions on, for example, the system structure or input signal content, can be identified which guarantee the stable operation of the filter, then the filter can be used in those applications with assurance that it will work. This section contains a review, therefore, of stability theory. In particular it covers the Lyapunov stability theorems that are used to prove the asymptotic stability of the new filtering methods presented herein.

Stability theory enables the user to draw conclusions about the stability of a system without deriving solution trajectories either analytically or numerically. This is often quite important because in most practical applications it is often difficult, if not impossible, to analytically derive solution trajectories, and it is typically not possible to probe and test, via simulation, all possible conditions that could affect the solution. An unstable case could be missed and a stability assessment of the system based on simulation could be incorrect.

Stability theory in general falls into two areas:

- Input-Output Stability
- Equilibrium Stability

Input-output stability assesses whether a particular class of inputs (usually magnitude bounded) will produce a bounded (i.e. stable) output. Equilibrium stability is concerned with the behavior of a dynamic system near or around an equilibrium point. Although our focus is on the latter, the control input u will be included in our evaluation of stability. As in most filtering problems, the control is assumed to be a known input which in many cases must be present to persistently excite the system, in order for all of the states to be observable.

The type of equilibrium stability that a system possesses can fall into a number of different categories. An equilibrium is said to be *stable* if all trajectories starting nearby remain nearby; it is unstable otherwise. It is called *asymptotically stable* if it is not only stable but also if all trajectories tend to the equilibrium as time approaches infinity. It is *uniformly stable*, or *uniformly asymptotically stable* if the character of the stable behavior (i.e. convergence speed) does not depend on the initial time. It is *exponentially stable* if

an exponential upper bound can be applied to the norm of the convergent error state, as is true in stable linear systems.

There are also different terms used to define the size of the region over which the stability property applies. A *region of attraction* is defined to be a region of the state space within which the state trajectories are guaranteed to be stable and converging asymptotically to the equilibrium contained therein. A system is *globally stable* if the region of attraction is shown to be the entire state space. It is *semi-globally stable* if the region of attraction containing the equilibrium is large (i.e. not infinitesimal), but not the entire state space. A system is *locally stable* if the stability characteristics are assessed using a dynamic model obtained by linearization (of a nonlinear model). Local stability conclusions hold only within an infinitesimal region containing the equilibrium, where it can be assured that the linear terms dominate system behavior.

In the sections that immediately follow, existing theory on the stability of nonlinear dynamic systems is presented. Only that part of existing stability theory which is subsequently used herein is covered.

2.1.1 Lyapunov Stability

One of the most important contributions to the body of existing stability theory occurred about a century ago, made by the Russian mathematician, A.M.Lyapunov [24].

Lyapunov's method has received considerable use because of its applicability to nonlinear systems, and because it does not require the analytical derivation of solution trajectories.

A scalar continuously differentiable function $V(x)$ is postulated, defined in a domain $\Omega \in R^n$ containing the origin $x = 0$ (i.e. the equilibrium), where n is the number of state variables. This function $V(x)$ is said to be positive definite if $V(0)=0$ and $V(x)>0$ for

all $x \neq 0$. It is only positive semi-definite if $V(x) \geq 0$ for all x , and it is said to be negative semi-definite (definite) if $-V(x)$ is positive semi-definite (definite). Stability is assessed by examining the time rate of change of this positive definite function along solution trajectories as governed by the differential equations governing the system under study. If a proposed function can be found whose first derivative is always negative except at the origin, then asymptotic stability is assured. This is stated formally in the following theorem, where we consider the n^{th} order, time-varying dynamic system,

$$\dot{x} = f(x, t) \quad (2.1)$$

where $f(0, t) = 0$.

Theorem 2-1 (Asymptotic Stability) – For the system (2.1), if there exists a scalar function $V(x, t)$ with continuous $(\partial V / \partial x)$ and $(\partial V / \partial t)$, such that

- (a) $0 < \alpha(\|x\|^2) < V(x, t) < \beta(\|x\|^2)$ where $\alpha(0) = 0$, and $\alpha(\|x\|^2) \rightarrow \infty$ as $\|x\|^2 \rightarrow \infty$,
- (b) $\dot{V}(x, t) < \gamma(\|x\|^2) < 0$ for all x, t

where $\dot{V}(x, t) = \frac{\partial V}{\partial t} + \left(\frac{\partial V}{\partial x} \right)' f(x, t)$, then the system is asymptotic stable at the origin, globally [43].

A function $V(x, t)$ satisfying (a) and (b) is a Lyapunov function. If the function and conditions (a) and (b) are independent of the initial time, then the system is said to possess uniform asymptotic global stability. If the a function meets the conditions given above only in a limited region Ω , rather than for all x as $\|x\|^2 \rightarrow \infty$, then the system is said to be semi-globally asymptotically stable. The region Ω is called the region of attraction.

In Theorem 2-1, condition (b) guarantees that the time derivative function $\dot{V}(x,t)$ be negative definite. If $\dot{V}(x,t)$ is only negative semi-definite, then the stability classification degenerates from one of asymptotic stability to one of stability only. Clearly, if $\dot{V}(x,t)$ can go to zero at some point other than the origin, then it may be true that $\dot{x} = 0$ at that point and the system state has stopped progressing toward the origin under study. However, if $\dot{V}(x,t)$ is only negative semi-definite, and it can be shown that no solution state yielding $\dot{V}(x,t) = 0$ can exist forever except when $x = 0$, then it is possible to upgrade the stability classification to one of asymptotic stability.

In the above, system (2.1) is assumed to be time varying. If it is not, i.e.

$$\dot{x} = f(x) \quad (2.2)$$

where $f(0) = 0$, then the conditions for stability are much simpler, as follows:

Theorem 2-2 (Asymptotic Stability, Time Invariant Systems) – For the system (2.2),

if there exists a scalar function $V(x)$ with continuous $(\partial V/\partial x)$ such that

(a) $V(x) > 0$ for all $x \in \Omega$ except $x = 0$ where $V(0) = 0$, and

(b) $\dot{V}(x) = \left(\frac{\partial V}{\partial x} \right)' f(x) < 0$ for all $x \in \Omega$ except $x = 0$,

then the system possesses asymptotic stability in the region Ω . Again, if Ω is the entire state space, then system stability properties are global.

2.1.2 Stability of $\dot{e} = -L(t)e$ when $L(t) = L'(t) > 0$

The following n^{th} order ordinary differential equation

$$\dot{e} = -L(t)e \quad (2.3)$$

involving a matrix $L(t)$ that is symmetric, positive semi-definite and time-varying, is one that often occurs in filtering applications. In [31], the authors exploit this specific structure to establish conditions of global asymptotic stability of (2.3). In some of the new methods presented in Chapter 4 the error dynamics are of the form as given by (2.3). In these cases we use the following theorem to prove the stability of the method:

Theorem 2-3 – Suppose $L(t)$ is a symmetric positive semi-definite matrix of bounded piecewise continuous functions. Then the equation

$$\dot{e} = -L(t)e \quad (2.4)$$

is uniformly asymptotically stable if and only if there exist real number $a > 0$ and b such that

$$\int_{t_0}^t |L(\tau)w| d\tau \geq a(t - t_0) + b \quad (2.5)$$

for all $t \geq t_0 \geq 0$ and all fixed unit vectors w . A proof of this theorem can be found in [31].

If there exists a fixed vector w that causes the integrand of (2.5) to equal zero over the interval $[t_0, t]$, such that (2.5) is violated (i.e. the integral does not increase with time t , then any state e along the line cw , where c is a scalar constant, will result in $\dot{e} = 0$ and any point along that line is an equilibrium over that interval, clearly violating the conditions for asymptotic stability. Also, if there exists a fixed vector w such that the integrand $L(\tau)w \equiv 0$, then it is also true that the integral of $L(\tau)$ must be singular. Thus, as an alternative to condition (2.5), one can apply the following:

$$J(t, t_0) = \int_{t_0}^t L(\tau) d\tau \quad \text{is nonsingular for all } t > t_0, \text{ and} \quad (2.6)$$

$$\lim_{t \rightarrow \infty} J(t, t_0) = \infty \quad (2.7)$$

2.1.3 Observability

A stable observer can exist only for systems which are observable. A test for observability is therefore a useful first step in the development of any observer. A linear system $\dot{x} = A(t)x$, with observations $y = C(t)x$ is said to be observable if and only if it is possible to determine *any* arbitrary initial state $x(0)$ by using only a finite record $y(\tau)$, $t_o \leq \tau \leq t$, of the output. The general condition that holds for an observable linear time-varying system is the following:

Theorem 2-4 – (Observability Grammian) A system is observable if and only if the matrix:

$$M(t, t_o) = \int_{t_o}^t \Phi'(\lambda, t) C'(\lambda) C(\lambda) \Phi(\lambda, t) d\lambda \quad (2.8)$$

is nonsingular for some $t > t_o$, where $\Phi(\lambda, t)$ is the state-transition matrix of the system.

Proof of this observability theorem can be found in [16].

A test for observability in nonlinear systems of the form,

$$\dot{x} = f(x) + w$$

$$y = h(x) + v$$

is given by Isidori in [23], where it is shown that in an observable nonlinear system, the following is true:

$$\text{rank} \begin{bmatrix} dh(x) \\ dL_f h(x) \\ \vdots \\ dL_f^{n-1} h(x) \end{bmatrix} = n \quad (2.9)$$

In this expression, $dh(x)$ is shorthand notation for $\frac{dh}{dx}$, the Jacobian of $h(x)$, and $L_f h(x)$ is

the Lie derivative of $h(x)$ along vector field $f(x)$, defined recursively as

$$L_f^n h(x) = L_f (L_f^{n-1} h(x))$$

$$L_f h(x) = \frac{dh}{dx} f(x)$$

If the rank of the matrix given in (2.9) is less than n in some region of the state space, the system is not observable in that region.

2.2 Separate-Bias Kalman Filter

In [11], Friedland considers the problem of simultaneously estimating the state x and bias vector b of a linear process

$$\dot{x} = Ax + Bu + Eb + F\xi \quad (2.10)$$

with observations

$$y = Cx + Db + \eta \quad (2.11)$$

where $x \in \mathfrak{R}^n$ is the state vector, $b \in \mathfrak{R}^p$ is a vector of constant but unknown biases, $u \in \mathfrak{R}^k$ is the control vector, and $y \in \mathfrak{R}^m$ is the measurement vector. The vectors ξ and η are white Gaussian noise processes with spectral densities Q and R , respectively. The matrices A , B , C , D , E , and F are known and possibly time-varying. Friedland points out that one method for handling this estimation problem is through state augmentation. The bias vector b is appended to the original state vector x , $x_a = \{x' \quad b'\}'$, and a new state equation is formed by augmenting the original process dynamics (2.10) with the bias dynamic equation

$$\dot{b} = 0 \quad (2.12)$$

The filter then estimates the bias terms as well as the state of the original problem. This method is reasonably effective when the number of bias terms is small relative to the

number of states. Then, the bias does not significantly increase the dimension of the new problem. On the other hand, when the number of bias terms is comparable to or larger than the number of states of the original problem, the augmented state vector is substantially larger in dimension than that of the original problem. As a result, the filter implementation involves computations with much larger matrices which increases the likelihood of numerical conditioning difficulties, and in some cases precludes their solution and the accurate estimation of the state and bias.

The Separate-Bias Kalman filter as given originally in [11], reduces the likelihood of numerical conditioning problems by separating the state and parameter filtering equations into two separate filters that run in parallel, thereby reducing the sizes of the matrices involved. An optimal estimate \hat{x} of the state x of the dynamic system, (2.10) and (2.11), is obtained by summing the “bias-free” state estimate \tilde{x} , computed as if no bias were present, and a bias correction term $V\hat{b}$:

$$\hat{x} = \tilde{x} + V\hat{b} \quad (2.13)$$

The optimal bias estimate \hat{b} is obtained by processing the residuals of the bias-free state estimator, $y - C\tilde{x}$, in a filter that is separate and distinct from the bias-free filter, as shown in Figure 2.1.

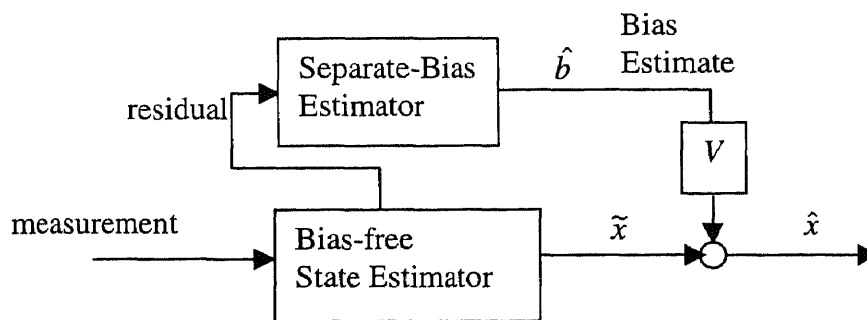

Figure 2.1 Separate-Bias Full-order Kalman Filter

The Bias-Free State Estimator is given by

$$\dot{\tilde{x}} = A\tilde{x} + Bu + \tilde{K}(y - C\tilde{x}) \quad (2.14)$$

with the gain matrix

$$\tilde{K} = \tilde{P}C'R^{-1} \quad (2.15)$$

and bias-free covariance matrix \tilde{P} given by the standard equation for the covariance of the estimation error in the absence of bias

$$\dot{\tilde{P}} = A\tilde{P} + \tilde{P}A' - \tilde{P}C'R^{-1}C\tilde{P} + Q \quad (2.16)$$

$$\tilde{P}(0) = \tilde{P}_0 = E\left[(\hat{x}(0) - x(0))(\hat{x}(0) - x(0))'\right]$$

The Separate-Bias Estimator is given by

$$\dot{\hat{b}} = M(V'C' + D')R^{-1}\left[-(CV + D)\hat{b} + (y - C\tilde{x})\right] \quad (2.17)$$

with the bias gain matrix V and the bias covariance matrix M given by the dynamic equations

$$\dot{V} = (A - \tilde{P}C'R^{-1}C)V + (B - \tilde{P}C'R^{-1}C) \quad V(0) = 0_{pxp} \quad (2.18)$$

$$\dot{M} = -M(V'C' + D')R^{-1}(CV + D)M \quad (2.19)$$

$$M(0) = P_b = E\left[(\hat{b}(0) - b(0))(\hat{b}(0) - b(0))'\right]$$

Discussion Over the last 30 years, Friedland's Separate-Bias Kalman filter has received considerable attention. Alternate derivations have been developed by Mendel and Washburn [28] and by Ignagni [21]. A suboptimal filter was derived by Ignagni for the case of time-varying bias[22]. An extended Kalman filter type of the separate-bias estimator for nonlinear systems was developed by Mendel [29]. The Separate-bias

estimator has received this attention for two primary reasons: (1) many physical systems naturally take the separate-bias form, so that its application is convenient, and (2) it provides an inherent numerical stability and efficiency that can yield improved performance. To see this, compare equations (2.16), (2.18), and (2.19), to the equation they replace, the $(n+k)^{th}$ order covariance equation that arises with the augmented system,

$$\dot{\tilde{P}}_a = A_a \tilde{P}_a + \tilde{P}_a A'_a - \tilde{P}_a C'_a R^{-1} C_a \tilde{P}_a + Q_a \quad (2.20)$$

where A_a and C_a are the augmented system matrices, Q_a the augmented plant noise matrix, and \tilde{P}_a the covariance matrix for the augmented system. Upon examination, one finds that the same number of differential equations are involved in either case; however, the number of *simultaneous* nonlinear differential equations which must be integrated to propagate (2.16), (2.18), and (2.19) is less than the number involved in the propagation of (2.20). Equation (2.18) depends only on the solution \tilde{P} to (2.16), and (2.19), in turn, depends only on the solution to (2.18). Thus (2.16), (2.18), and (2.19) are serially (not mutually) coupled, and consequently they can be solved sequentially rather than simultaneously. On the other hand, (2.20) involves the same number of mutually coupled, simultaneous differential equations. Since numerical integration errors increase rapidly with the number of simultaneous equations integrated, the estimated state and bias covariance as given by (2.16) through (2.19) can be expected to be more accurate than that given by (2.20). Thus, the separate-bias full-order Kalman filter can be, and apparently often is, better conditioned numerically than the centralized Kalman filter arising with state augmentation.

2.3 Reduced-order Kalman Filter

The reduced-order Kalman filter to be used in herein applies to the systems that can be represented as:

$$\dot{x} = Ax + Bu + F\xi \quad (2.21)$$

$$y = Cx \quad (2.22)$$

where $x \in \mathfrak{R}^n$ is the state vector, $y \in \mathfrak{R}^m$ is the observation vector, $u \in \mathfrak{R}^k$ is the control vector, ξ is the white process noise vector with spectral density matrix Q , and where A , B , F , and C are known, possibly time-varying coefficient matrices of appropriate dimension. Observation noise is absent, as is the basic assumption with the reduced-order Kalman filter. Also, without any great loss in generality, it is assumed that the state variables are defined so that the first m of them are measured directly (i.e. $C = [I \ 0]$) and the remaining $n-m$ are not measured at all. This corresponds to a partitioning of the state vector and matrices in (2.23) and (2.24) as follows:

$$\begin{bmatrix} \dot{\bar{x}}_1 \\ \dot{\bar{x}}_2 \end{bmatrix} = \begin{bmatrix} \bar{A}_{11} & \bar{A}_{12} \\ \bar{A}_{21} & \bar{A}_{22} \end{bmatrix} \begin{bmatrix} \bar{x}_1 \\ \bar{x}_2 \end{bmatrix} + \begin{bmatrix} \bar{B}_1 \\ \bar{B}_2 \end{bmatrix} u + \begin{bmatrix} \bar{F}_1 \\ \bar{F}_2 \end{bmatrix} \xi \quad (2.23)$$

(The overbars are used here for consistency with the notation employed in Section 4.3.3)

Filtering Equations The reduced-order Kalman filter for the process with the matrices partitioned as above is given by [15]

$$\hat{\bar{x}}_1 = y \quad (2.24)$$

$$\hat{\bar{x}}_2 = z + Ky \quad (2.25)$$

with

$$\dot{z} = (\bar{A}_{22} - K\bar{A}_{12})\hat{\bar{x}}_2 + (\bar{A}_{21} - K\bar{A}_{11} - \dot{K})y + (\bar{B}_2 - K\bar{B}_1)u \quad (2.26)$$

The Kalman gain K and covariance P of the error in estimating \bar{x}_2 are given by

$$K = (P\bar{A}'_{12} + \bar{F}_2 Q \bar{F}'_1) W^{-1} \quad (2.27)$$

$$\dot{P} = \tilde{A}P + P\tilde{A}' - P\bar{A}'_{12}W^{-1}\bar{A}_{12}P + \bar{F}_2\tilde{Q}\bar{F}'_2 \quad (2.28)$$

where

$$\tilde{A} = \bar{A}_{22} - \bar{F}_2 Q \bar{F}'_1 W^{-1} \bar{A}_{12} \quad (2.29)$$

$$\tilde{Q} = Q - Q \bar{F}'_1 W^{-1} \bar{F}_1 Q \quad (2.30)$$

$$W = \bar{F}_1 Q \bar{F}'_1 \quad (2.31)$$

The time derivative of the Kalman gain matrix in (2.26) can be generated by differentiating (2.27) with the help of (2.28). Also, in these expressions it is assumed that the matrix W is nonsingular, or equivalently, that the submatrix \bar{F}_1 is of full rank. A reduced-order Kalman filters of this form can therefore exist only for systems which have an independent source of noise driving each element of \bar{x}_1 , the vector of directly measured states in (2.23).

Equations (2.24)-(2.31) completely define the reduced-order Kalman filter and will serve as a starting point for the development of the Separate-bias Reduced-order Kalman filter in Section 4.3.

2.4 State Dependent Algebraic Riccati Equation Filter

A new filtering technique known as the State Dependent Algebraic Riccati Equation (SDARE) filter [32], is reviewed here and is applied in Section 4.3 to the joint state and parameter estimation problem. In general, it applies to general nonlinear systems having the form:

$$\dot{x} = f(x) + w \quad (2.32)$$

with measurement vector

$$y = h(x) + v \quad (2.33)$$

where the functions $f(x)$ and $h(x)$ are vectors of nonlinearities, $x \in \mathfrak{R}^n$, $y \in \mathfrak{R}^m$, and the inputs w and v are gaussian, zero mean white process and measurement noise respectively, with spectral density matrices W and V : i.e. $E[w(t)w'(t+\tau)] = W(t)\delta(t-\tau)$ and $E[v(t)v'(t+\tau)] = V(t)\delta(t-\tau)$. The SDARE method provides a suboptimal solution to the nonlinear estimation problem (see [32]) as follows. First, the nonlinear system (2.32) is converted to state dependent coefficient (SDC) form:

$$\dot{x} = F(x)x + w \quad (2.34)$$

$$y = H(x)x + v \quad (2.35)$$

where $F(x)x = f(x)$ and $H(x)x = h(x)$. A filter having the form of a Luenberger observer, but with state estimate dependent matrices is constructed:

$$\dot{\hat{x}} = F(\hat{x})\hat{x} + K_f(\hat{x})[y(x) - H(\hat{x})\hat{x}] \quad (2.36)$$

with a filter gain given by

$$K_f(\hat{x}) = P(\hat{x})H'(\hat{x})V^{-1} \quad (2.37)$$

$P(\hat{x})$ is the positive definite solution to the state-estimate-dependent algebraic Riccati equation

$$F(\hat{x})P + PF'(\hat{x}) - PH'(\hat{x})V^{-1}H(\hat{x})P + W = 0 \quad (2.38)$$

A unique positive definite solution for all \hat{x} [in region Ω] can be obtained to equation (2.38) if either:

- the system is asymptotically stable, i.e. $F(\hat{x})$ is a Hurwitz matrix for all $\hat{x} [\in \Omega]$, or
- the system defined by the pair $[F(\hat{x}), H(\hat{x})]$ is observable and the system defined by the pair $[F(\hat{x}), W^{1/2}]$ is controllable for all $\hat{x} [\in \Omega]$.

More detail on the theory and application of the SDARE approach can be found in [8] and [9], where the authors develop the SDARE regulator for nonlinear control.

CHAPTER 3

EXISTING METHODS, AN OVERVIEW

This chapter describes existing continuous-time methods for the on-line estimation of parameters only, and for the on-line simultaneous estimation of the state and parameters, in linear and nonlinear, continuous-time dynamic systems. The parameter estimation problem arises when the entire state vector is available, i.e. $m=n$, so that only θ need be estimated. The state and parameter estimation problem occurs when $m<n$, so that both x and θ must be estimated simultaneously. These are discussed in Sections 3.1 and 3.2, respectively.

3.1 Parameter Estimation

The methods of this section apply to systems that can be represented by the following equations

$$\dot{x}(t) = A(t)x(t) + B(t)u(t) + E(t, x, u)\theta + g(t, x, u) \quad (3.1)$$

The entire state vector is assumed to be available, i.e. $y(t) = x(t)$. The vector of unknown parameters, θ , appears linearly in the dynamics through multiplication with the known coefficient matrix $E(t, x, u)$. These parameters are to be estimated. You will recognize this as System Class B.

3.1.1 Standard Linear Theory

The linear parameter estimation problem defined above can be readily handled by standard reduced-order observer and estimation theory. This is demonstrated with the following two theorems.

Theorem 3-1 – Let $\hat{\theta}$ represent the estimate of the unknown parameter vector. Given the system described by equation (3.1), if a matrix $K(t)$ can be found such that the matrix product $K(t)E(t)$ is a fixed (i.e. constant) Hurwitz matrix, then the parameter observer,

$$\begin{aligned}\hat{\theta} &= Kx + z \\ \dot{z} &= -K(Ax + Bu + E\hat{\theta} + g(t, x, u)) - \dot{K}x\end{aligned}\tag{3.2}$$

is globally asymptotically stable. (Note that the functional dependence of the observer dynamics on time is not shown in (3.2) to simplify the notation.)

Proof The estimation error:

$$e_{\theta} = \theta - \hat{\theta}$$

is differentiated to define the error dynamics. Noting that $\dot{\theta} = 0$,

$$\begin{aligned}\dot{e}_{\theta} &= -\dot{\hat{\theta}} = -K\dot{x} - \dot{K}x - \dot{z} \\ &= -K(Ax + Bu + E\theta + g(t, x, u)) - \dot{K}x \\ &\quad + K(Ax + Bu + E\hat{\theta} + g(t, x, u)) + \dot{K}x \\ \dot{e}_{\theta} &= -KEe_{\theta}\end{aligned}$$

Since KE is a constant Hurwitz matrix, the observation error will decay asymptotically to zero regardless of initial condition, thus the observer (3.2) is globally asymptotically stable. \square

Note 1 The problem defined above is often referred to as a bias estimation problem with θ representing the unknown biases and with $E(t)$ being a fixed coefficient matrix. In any practical problem the rank of E will equal the number of unknown biases p ; i.e. each bias will impact the state. That being the case, it is always possible to determine a fixed K matrix such that KE is a fixed Hurwitz matrix, thereby satisfying Theorem 3-1.

Note 2 Practical applications do exist which involve a time-varying E matrix, and in some cases it is this time variation that enables the design of an asymptotically stable parameter observer by Theorem 3-1. In the calibration of an inertial system, for example, the matrix $E(t)$ is a piece-wise constant function that depends on the orientation of the input rate and acceleration vectors. During well defined time segments, E is a known constant matrix, and an appropriate K is applied that causes specific elements of the parameter error vector to converge to zero. The overall calibration experiment must be constructed so that over the entire calibration time interval, the entire parameter vector is estimated. An experiment that achieves this will also meet the observability grammian rank condition given in Theorem 2-4 above.

Note 3 Another way to generate a $K(t)$ yielding global asymptotic stability when $E(t)$ is time-varying is via the reduced-order Kalman filter described in Sec. 2.3. In [14] Friedland presents the full-order Kalman filter as a method for the estimation of uncertain parameters in dynamic stochastic systems. It appears, however, that no one has suggested in the open literature that the reduced-order Kalman filter be used for parameter estimation in linear or nonlinear systems in cases where the entire state vector is available. Nevertheless, it seems like a fairly obvious application of the theory, therefore it is presented below in order to provide a complete background of the existing techniques.

Theorem 3-2 – Consider the system

$$\begin{aligned}\dot{x}(t) &= A(t)x(t) + B(t)u(t) + E(t, x, u)\theta + g(t, x, u) + w_x(t) \\ \dot{\theta} &= w_\theta(t)\end{aligned}\tag{3.3}$$

where w_θ and w_x are white gaussian noise processes of appropriate dimension and with spectral density matrices Q_θ and Q_x , respectively. (Since the Kalman filter applies to stochastic systems, process noise is included in the parameter dynamics as well as in the state, although when the parameters are truly constants it is allowable to set $Q_\theta=0$.)

If the system is observable by Theorem 2-4, (with $\Phi(\lambda, t)$ the state transition matrix of the augmented system (3.3), and $C = \begin{bmatrix} I_n & 0_{n \times p} \end{bmatrix}$), then the parameter observer, given by (3.2) with gain and covariance:

$$\begin{aligned} K(t) &= PE'(t)Q_x^{-1} \\ \dot{P} &= -PE'(t)Q_x^{-1}E(t)P + Q_\theta \end{aligned} \quad (3.4)$$

and initial covariance $P(0) = P_0$, is globally and asymptotically stable. The derivative of K can be calculated with the equation

$$\dot{K}(t) = (\dot{P}E'(t) + P\dot{E}'(t))Q_x^{-1} \quad (3.5)$$

Proof Application of the equations for the reduced-order Kalman filter, (2.23) through (2.30), to the augmented system

$$\begin{bmatrix} \dot{x} \\ \dot{\theta} \end{bmatrix} = \begin{bmatrix} A(t) & E(t) \\ 0 & 0 \end{bmatrix} \begin{bmatrix} x \\ \theta \end{bmatrix} + \begin{bmatrix} B(t) \\ 0 \end{bmatrix} u + \begin{bmatrix} g(t, x, u) \\ 0 \end{bmatrix} + \begin{bmatrix} w_x \\ w_\theta \end{bmatrix}$$

with $y = \hat{x}_1 = x$ and $\hat{x}_2 = \hat{\theta}$ yields state and covariance equations (3.2) and (3.4) as given above. Thus, (3.2) and (3.4) together comprise the reduced-order Kalman filter for estimating the unknown parameters of (3.1). The parameter states are assumed to be observable, satisfying Theorem 2-4, therefore by standard Kalman filtering theory, the filter given by (3.2) and (3.4) is optimal and guaranteed to yield asymptotically convergent parameter estimates, globally. \square

3.1.2 Narendra and Kudva's Method

In Section 3.4 of [33], Narendra and Kudva develop a method for identifying linear time-invariant systems of the form

$$\dot{x} = Ax + Bu + Cg(x)$$

where the entire state vector x is available, where the matrices A , B , C are unknown (i.e. contain unknown parameters). A similar method is contained in [27]. For consistency with the rest of this manuscript, we consider the following equivalent form:

$$\dot{x} = Ax + Bu + E(t, x, u)\theta + g(t, x, u) \quad (3.6)$$

where the matrices A and B are known, θ is the vector of unknown parameters, and $E(x, u)$ is a matrix and $g(x, u)$ a vector of known, possibly nonlinear functions of x and u .

For the system having the form (3.6), Narendra and Kudva's proposed filter has the following form:

$$\dot{\hat{x}} = Ax + Bu + A_F(x - \hat{x}) + E(t, x, u)\hat{\theta} + g(t, x, u) \quad (3.7)$$

$$\dot{\hat{\theta}} = E'(t, x, u)P(x - \hat{x}) \quad (3.8)$$

The matrix $A_F \in \mathfrak{R}^{n \times n}$ is a Hurwitz matrix chosen by the designer, and $P \in \mathfrak{R}^{n \times n}$ is a symmetric positive definite matrix to be defined by the solution of the Lyapunov equation

$$A_F'P + PA_F = -Q < 0$$

Theorem 3-3 – Consider the system (3.6) and the state and parameter filters (3.7) and (3.8) with A_F a Hurwitz matrix. The convergence of the filter estimates to their true values is guaranteed, both globally and asymptotically.

Proof The following candidate Lyapunov function is proposed;

$$V = e_x' P e_x + e_\theta' e_\theta \quad (3.9)$$

The state and parameter errors,

$$e_x = x - \hat{x}$$

$$e_\theta = \theta - \hat{\theta}$$

are differentiated for use in the candidate Lyapunov function, yielding;

$$\begin{aligned} \dot{e}_x &= \dot{x} - \dot{\hat{x}} \\ &= E(x, u)e_\theta + A_F e_x \end{aligned}$$

$$\begin{aligned} \dot{e}_\theta &= -\dot{\hat{\theta}} \\ &= -E'(t, x, u)P e_x \end{aligned}$$

Taking the time derivative of V along e_x and e_θ yields

$$\dot{V} = 2e_\theta' [E' P e_x + \dot{e}_\theta] + e_x' [A_F' P + P A_F] e_x \quad (3.10)$$

Clearly, the parameter update law causes the first term to drop out, leaving only the second. Since A_F is a fixed Hurwitz matrix, it is always possible to solve the Lyapunov equation

$$A_F' P + P A_F = -Q < 0 \quad (3.11)$$

for a positive definite matrix P , given any $n \times n$ symmetric, positive-definite matrix Q .

With (3.11) and the parameter observation law (3.8), the function (3.10) becomes

$$\dot{V} = -e_x' Q e_x \leq 0$$

Hence, V is a Lyapunov function and the equilibrium $\{e_x, e_\theta\} = \{0, 0\}$ is globally asymptotically stable.

Discussion Narendra's and Kudva's method can be applied to the same problem as that handled by the reduced-order Kalman filter discussed above; however, it can be less demanding computationally. When comparing the two, one notes that the Narendra and Kudva filter involves an additional n^{th} order state estimator, but does not include the $p \times p^{\text{th}}$

order parameter covariance update matrix differential equation. Thus, the number of independent differential equations with Narendra and Kudva is $(n + p)$, whereas with the reduced-order Kalman filter it is $p(p + 3)/2$. The computational advantage of the Narendra-Kudva filter becomes more pronounced as the number of parameters increases.

3.1.3 Friedland's Parameter Estimator

The parameter estimation method developed by Friedland [17] also applies to nonlinear systems of the form (3.1); i.e. to systems affine in the unknown parameter. His parameter observer is given by

$$\hat{\theta} = \phi(x) + z \quad (3.12)$$

$$\dot{z} = -\Phi(x)[Ax + Bu + E(x, u)\hat{\theta} + g(x, u)] \quad (3.13)$$

where $\phi(x)$ is an appropriately chosen nonlinear function and $\Phi(x)$ is its Jacobian matrix:

$$\Phi(x) = \partial\phi_i(x)/\partial x_j$$

The differential equation for the propagation of the parameter estimation error

$$\begin{aligned} \dot{e}_\theta &= -\dot{\hat{\theta}} \\ &= -\Phi(x)\dot{x} - \dot{z} \\ &= -\Phi(x)E(x, u)e_\theta \end{aligned}$$

is a linear equation of the form

$$\dot{e} = -L(t)e \quad (3.14)$$

where $L(t) = \Phi(x(t))E(x(t), u(t))$. Thus, the problem is to find a $\phi(x)$ yielding a $\Phi(x)$ such that (3.14) is stable.

Theorem 3-4 – Consider the nonlinear system (3.6) and the parameter estimator given by (3.12) and (3.13). If $\phi(x)$ can be chosen such that $L(t)$ as given by

$$L(t) = \Phi(x)E(x, u)$$

is a positive semi-definite symmetric matrix, i.e.

$$L(t) = C'(t)C(t) > 0 \quad (3.15)$$

and such that $J(T, t_0) := \int_{t_0}^T L(\tau)d\tau$ is nonsingular for all $T > t_0$ and $\lim_{T \rightarrow \infty} J(T, t_0) = \infty$, then convergence of the parameter estimation error is assured.

Proof One way to achieve the required symmetry and positive semi-definiteness is by setting $\Phi(x) = E(x, u)'V$, where V is a positive definite matrix. For the complete proof, see [17]. \square

Discussion Friedland's method is the simplest computationally. The parameter estimate is given by a single vector differential equation of order p , as compared to $(n + p)$ and $p(p + 3)/2$ for the Narendra-Kudva (NK) and reduced-order Kalman filters, respectively. However, while the NK and Kalman parameter estimators can always be applied, the application of Friedland's estimator depends on the user's ability to find a $\phi(x)$ such that (3.15) holds true, and this may be a difficult in some cases. If a suitable $\phi(x)$ cannot be found, then one can abandon that approach and turn to either the NK or Kalman filter approaches, which can both definitely be applied at a higher computational cost.

3.2 State and Parameter Estimation

Section 3.1 discussed existing methods for continuous-time parameter estimation in systems falling into System Class B, with full state availability, $y(t)=x(t)$, i.e. the parameter estimation problem. In this section, existing methods for simultaneous state and parameter estimation for systems of Class B and partial state availability are

presented. These include the methods of Narendra and Annaswamy, Bastin and Gevers, Rusnak, and Raghavan. In addition, the application of standard Kalman filtering theory to this problem is covered. Thus, we are considering

$$\begin{aligned}\dot{x}_1(t) &= A_{11}(t)x_1(t) + A_{12}(t)x_2(t) + B_1(t)u(t) + E_1(t, y, u)\theta(t) + g_1(t, y, u) + F_1(t)w \\ \dot{x}_2(t) &= A_{21}(t)x_1(t) + A_{22}(t)x_2(t) + B_2(t)u(t) + E_2(t, y, u)\theta(t) + g_2(t, y, u) + F_2(t)w \\ y(t) &= x_1(t)\end{aligned}\quad (3.16)$$

3.2.1 Standard Linear Theory

Because the nonlinear functions $E_1()$, $E_2()$, $g_1()$, and $g_2()$ in (3.16) depend only on known quantities, t , $y(t)$, and $u(t)$, (3.16) can be represented equivalently as

$$\begin{aligned}\dot{x}_1(t) &= A_{11}(t)x_1(t) + A_{12}(t)x_2(t) + B_1(t)u(t) + E_1(t)\theta(t) + F_1(t)w \\ \dot{x}_2(t) &= A_{21}(t)x_1(t) + A_{22}(t)x_2(t) + B_2(t)u(t) + E_2(t)\theta(t) + F_2(t)w \\ y(t) &= x_1(t)\end{aligned}\quad (3.17)$$

where $g_1()$ and $g_2()$ have been absorbed into the A_{11} and A_{21} terms. Therefore, the state and parameter estimation problem defined above can be readily handled by standard linear reduced-order observer and estimation theory. This is demonstrated in the following two theorems.

Theorem 3-5 – Given the system described by equation (3.17), if matrices $K_1(t)$ and $K_2(t)$ can be found such that the matrix

$$\begin{bmatrix} A_{22}(t) - K_1(t)A_{12}(t) & E_2(t) - K_1(t)E_1(t) \\ -K_2(t)A_{12}(t) & -K_2(t)E_1(t) \end{bmatrix}\quad (3.18)$$

is a fixed (i.e. constant) Hurwitz matrix, then the observer

$$\begin{aligned}
\hat{x}_1 &= y \\
\hat{x}_2 &= z_1 + K_1 y \\
\hat{\theta} &= z_2 + K_2 y
\end{aligned} \tag{3.19}$$

$$\begin{aligned}
\dot{z}_1 &= (A_{22} - K_1 A_{12})\hat{x}_2 + (E_2 - K_1 E_1)\hat{\theta} + (A_{21} - K_1 A_{11})y - g_1(t, y, u) - \dot{K}_1 y \\
\dot{z}_2 &= -K_2(A_{12}\hat{x}_2 + E_1\hat{\theta} + A_{11}y + B_1 u) - K_2 g_1(t, y, u) - \dot{K}_2 y
\end{aligned} \tag{3.20}$$

is globally asymptotically stable.

Proof Substitution of (3.17), (3.19) and (3.20) into the derivatives of $e_x = x_2 - \hat{x}_2$ and

$e_\theta = \theta - \hat{\theta}$ yields

$$\begin{aligned}
\dot{e}_x &= (A_{22} - K_1 A_{12})e_x + (E_2 - K_1 E_1)e_\theta + (F_2 - K_1 F_1)w \\
\dot{e}_\theta &= -K_2 A_{12}e_x - K_2 E_1 e_\theta - K_2 F_1 w
\end{aligned}$$

or

$$\begin{bmatrix} \dot{e}_x \\ \dot{e}_\theta \end{bmatrix} = \begin{bmatrix} A_{22}(t) - K_1(t)A_{12}(t) & E_2(t) - K_1(t)E_1(t) \\ -K_2(t)A_{12}(t) & -K_2(t)E_1(t) \end{bmatrix} \begin{bmatrix} e_x \\ e_\theta \end{bmatrix} + \begin{bmatrix} F_2 - K_1 F_1 \\ F_1 \end{bmatrix} w$$

Since this error dynamics equation involves a constant Hurwitz matrix by assumption, the observer (3.19)-(3.20) is globally asymptotically stable. \square

Note 1 If the matrices in (3.17) are time-varying, and it is difficult to find $K_1(t)$ and $K_2(t)$ matrices that such that (3.18) is constant, then the user can resort to the reduced-order Kalman filter, i.e. (3.19)–(3.20), with appropriate gain and covariance matrices.

As an alternative, the separate-bias reduced-order Kalman filter, a new method developed herein and discussed in Section 4, can also be employed.

Note 2 Rusnak, et.al., in [38] and [40], examine the use of the Kalman filter for simultaneous state and parameter estimation in single-input, single-output systems. In particular, they focus on the persistence of excitation conditions needed to guarantee

observability. In [39], these same authors extend their analysis of observability to multi-input, multi-output (MIMO) systems using non-minimal realizations of the plant.

However, if the system is of System Class B, there is no need to convert to a non-minimal form, as one can apply the full or reduced-order Kalman filters to the augmented MIMO system directly.

3.2.2 Narendra and Annaswamy's Method

A method for simultaneous state and parameter estimation in single-input single-output (SISO), linear, time-invariant systems is developed by Narendra and Annaswamy in [34].

They use the fact that any controllable and observable SISO system

$$\begin{aligned}\dot{x} &= A(\theta)x + b(\theta)u \\ y &= x_1\end{aligned}$$

of order n , with unknown parameters θ can be represented by the following non-minimal $(2n-1)^{\text{th}}$ order system:

$$\begin{aligned}\dot{x}_1 &= -\lambda x_1 + \theta' w \\ \dot{\omega}_1 &= \Lambda \omega_1 + l u \\ \dot{\omega}_{21} &= \Lambda \omega_2 + l y \\ y &= x_1\end{aligned}$$

where $w = [u' \quad \omega_1' \quad y \quad \omega_2']$, $\omega_1 \in \mathfrak{R}^{n-1}$, $\omega_2 \in \mathfrak{R}^{n-1}$, and $x_1 \in \mathfrak{R}^1$, and where the scalar λ and the matrix Λ are user selectable design parameters. The authors propose for this system the following state observer:

$$\dot{\hat{x}}_1 = -\lambda \hat{x}_1 + \theta' w$$

$$\dot{\hat{\omega}}_1 = \Lambda \hat{\omega}_1 + l u$$

$$\dot{\hat{\omega}}_2 = \Lambda \hat{\omega}_2 + l y$$

$$\hat{y} = \hat{x}_1$$

and parameter adaptation law

$$\dot{\hat{\theta}} = -(\hat{y} - y)\Gamma \hat{w}$$

where Γ is a user defined, diagonal weighting matrix. A proof of stability for this system can be found in [34] and will not be repeated here. Some points to note regarding this method:

- (1) It applies only to SISO time-invariant systems,
- (2) The states of the original system are not estimated; those of the equivalent system are estimated, and to examine these states, an inverse transformation must be applied.
- (3) The designer of the observer is given no guidance in selecting l , λ , or Λ .

3.2.3 Bastin and Gevers' Method

Bastin and Gevers develop in [3] a globally stable state and parameter observer for single-input single-output nonlinear systems that can be represented as:

$$\begin{aligned} \dot{x}(t) &= R x(t) + \Omega(y, u) \theta(t) + g(t) \\ y(t) &= C x(t) \end{aligned} \tag{3.21}$$

where $C = [1 \ 0 \ \dots \ 0]$, and where R is of the form

$$R = \left[\begin{array}{c|c} 0 & k' \\ \hline 0 & \\ \vdots & F(c_2, c_3, \dots, c_n) \\ 0 & \end{array} \right] \tag{3.22}$$

with

$$k' \equiv [k_2 \quad k_3 \quad \dots \quad k_n]$$

a vector of known constants, $F(c_2, c_3, \dots, c_n) \in \mathfrak{R}^{(n-1) \times (n-1)}$ a constant matrix, and

$\{c_2 \dots c_n\}$ a set of design parameters to be selected by the user. Note that (R, C) must be an observable pair. The unknown parameters in (3.21) multiply functions of only known quantities, therefore this system falls into System Class B. For this system, the authors propose the following state and parameter observer:

$$\dot{\hat{x}} = R\hat{x} + \Omega(y, u)\hat{\theta} + g(t) + \begin{bmatrix} c_1 \\ V(t)\dot{\hat{\theta}}(t) \end{bmatrix}$$

$$\hat{y} = \hat{x}_1$$

$$e = y - \hat{y}$$

$$\dot{\hat{\theta}} = \Gamma\phi(t)e$$

$$\dot{V} = FV + \overline{\Omega}(y, u), \quad V(0) = 0 \quad V \in \mathfrak{R}^{(n-1) \times n}$$

$$\phi(t) = V\hat{k} + \Omega'_1(y, u) \quad \phi \in \mathfrak{R}^{n \times 1}$$

where c_1 is an arbitrary positive scalar, Γ is an arbitrary positive definite matrix, and

where $\Omega_1(\cdot)$ is the first row of $\Omega(y, u)$ and $\overline{\Omega}(\cdot)$ the remaining rows, i.e.

$$\Omega(y, u) = \left[\begin{array}{c} \text{---} \frac{\Omega_1}{\Omega} \text{---} \\ \updownarrow 1 \\ \updownarrow n-1 \end{array} \right]$$

In [3] the authors demonstrate the transformation of several physical systems into the necessary form given by (3.21)-(3.22). Conditions permitting the application of a nonlinear change of coordinates to transforms somewhat more general nonlinear systems into this form are provided by Ricardo in [37].

3.2.4 Raghavan's Method

Raghavan, in [36], also considers the class of system we have defined as System Class B;

$$\begin{aligned}\dot{x} &= Ax + g(t, y, u) + E(t, y, u)\theta \\ y &= Cx\end{aligned}\tag{3.23}$$

where for ease of notation the control input $B(t)u$ is assumed to be contained in $g()$ and the plant noise is dropped. Raghavan assumes that both A and C are constant matrices and that the pair $[A, C]$ is observable. For this system he develops the observer given below, involving the following two auxiliary filters:

$$\dot{\Psi}(t) = (A - LC)\Psi(t) + E(t, y, u)\tag{3.24}$$

$$\dot{\xi}(t) = (A - LC)\xi(t) + Ly + g(t, y, u)\tag{3.25}$$

where $\Psi \in \mathcal{R}^{n \times p}$ and $\xi \in \mathcal{R}^n$. The matrix L is chosen to place the eigenvalues of $A - LC$ in the open left half plane. Both are initialized to zero, i.e. $\Psi(0) = 0_{n \times p}$, $\xi(0) = 0_n$. The state observer is given by

$$\hat{x}(t) = \xi(t) + \Psi(t)\hat{\theta}\tag{3.26}$$

with the parameter update law

$$\dot{\hat{\theta}} = k\Psi'C'(y - Cx)\tag{3.27}$$

where k is an arbitrary positive scalar.

Stability Analysis Notice that the system dynamics (3.23) can be represented

$$\dot{x} = (A - LC)x + Ly + g(t, y, u) + E(t, y, u)\theta$$

The solution to the system dynamics equations (3.23) can therefore be written as

$$x(t) = e^{(A-LC)t}x(0) + \int_0^t e^{(A-LC)(t-\tau)}(Ly + g(\tau, y, u))d\tau + \int_0^t e^{(A-LC)(t-\tau)}E(\tau, y, u)d\tau\theta$$

From this, Raghavan notes that the true state $x(t)$ can be written in terms of the solutions to the auxiliary filter equations:

$$x(t) = e^{(A-LC)t}x(0) + \xi(t) + \Psi(t)\theta\tag{3.28}$$

The state estimation error $e_x = x - \hat{x}$ is thus readily shown to be

$$e_x = e^{(A-LC)t} x(0) + \Psi(t)e_\theta$$

where $e_\theta = \theta - \hat{\theta}$. The parameter estimation error dynamics are derived similarly,

$$\begin{aligned} \dot{e}_\theta &= -\dot{\hat{\theta}} = -k\Psi' C' C(x - \hat{x}) \\ &= -k\Psi' C' C e_x \\ &= k\Psi' C' C(e^{(A-LC)t} x(0) + \Psi(t)e_\theta) \end{aligned}$$

Since $A-LC$ is Hurwitz, the initial condition term decays to zero, leaving

$$\begin{aligned} \dot{e}_\theta &= k\Psi' C' C\Psi(t)e_\theta \\ &= -M(t)e_\theta \end{aligned}$$

Thus, $M(t)$ is a symmetric matrix, and by Theorem 2-3, if

$$J(t, t_0) = \int_{t_0}^t |M(\tau)| d\tau \text{ is nonsingular for all } t > t_0, \text{ and} \quad (3.29)$$

$$\lim_{t \rightarrow \infty} J(t, t_0) = \infty \quad (3.30)$$

then the observer is asymptotically stable globally.

CHAPTER 4

NEW METHODS

The five new methods developed as part of this dissertation effort are presented. Two do not involve the use of Riccati equations: (1) the nonlinear observer obtained by combining the methods of Raghavan and Friedland, and (2) the nonlinear observer obtained by directly extending Friedland's parameter observer to the case of partial state feedback. The remaining three are those that do involve Riccati equations. They are: (1) the Separate-bias Reduced-order Kalman filter, (2) the State Dependent Algebraic Riccati Equations (SDARE) filter applied to the problems of joint state and parameter estimation, and (3) the State Dependent Matrix Differential Riccati Equation (SDDRE) filter, proposed herein as a general filtering method and also applied to this joint estimation problem. The global stability of the first three methods is proven. The stability of the SDDRE filter when applied to bilinear systems of System Class C is examined and compared to that of the Extended Kalman Filter (EKF). A proof of semi-global stability of the EKF for this system class under mild assumptions is also provided.

4.1 Nonlinear Reduced-Order Observer 1

A globally stable algorithm for simultaneous estimation of the state and parameters in nonlinear dynamic system with partial state availability is derived by combining the concepts developed by Raghavan in [36] for the design of a full order observer (reviewed in Section 3.2.4) with the techniques used by Friedland in [16] to derive reduced-order estimators. The resulting filter has some nice advantages over the others. The new filter is of order $(n - m + p) + (n - m)p$, which is lower than that of the Raghavan [36],

the Narandra-Annaswamy (NA) [34], and the Bastion-Gevers (BG) [3] filters. In addition, the new filter is somewhat easier to apply than the NA and BG filters, in that it is not necessary to find and apply a coordinate transformation to bring the system into proper form.

4.1.1 System Class

We'll continue by considering the n^{th} order, multi-input, multi-output, uncertain nonlinear system having the form :

$$\dot{x}_1 = A_{11}(t)x_1 + A_{12}(t)x_2 + g_1(t, u, y) + E_1(t, u, y)\theta \quad (4.1)$$

$$\dot{x}_2 = A_{21}(t)x_1 + A_{22}(t)x_2 + g_2(t, u, y) + E_2(t, u, y)\theta \quad (4.2)$$

$$y = x_1 \quad (4.3)$$

where $x_2 \in \mathfrak{R}^{n-m}$ is the unknown state vector, $u \in \mathfrak{R}^k$ is the control vector, $y \in \mathfrak{R}^m$ is the measurement vector, and $\theta \in \mathfrak{R}^p$ is the unknown constant parameter vector. This is a noise-free version of System Class B. The terms $g_1 : \mathfrak{R} \times \mathfrak{R}^k \times \mathfrak{R}^m \rightarrow \mathfrak{R}^m$ and $g_2 : \mathfrak{R} \times \mathfrak{R}^k \times \mathfrak{R}^m \rightarrow \mathfrak{R}^{n-m}$ are known nonlinear functions. The matrices $E_1 : \mathfrak{R} \times \mathfrak{R}^k \times \mathfrak{R}^m \rightarrow \mathfrak{R}^{m \times p}$ and $E_2 : \mathfrak{R} \times \mathfrak{R}^k \times \mathfrak{R}^m \rightarrow \mathfrak{R}^{(n-m) \times p}$ are matrices of known nonlinear function that are affine in the unknown parameters. The matrices A_{11} , A_{12} , A_{21} , and A_{22} are known, possibly time-varying coefficient matrices.

4.1.2 Observer Equations

The state estimate will be given in the fashion typical of reduced-order observers:

$$\hat{x}_2 = \hat{z} + Ly \quad (4.4)$$

where L is to be a matrix to be determined by the user. The vector \hat{z} is given by

$$\hat{z} = \xi(t) + \Psi(t)\hat{\theta} \quad (4.5)$$

where $\hat{\theta} = [\hat{\theta}_1, \dots, \hat{\theta}_p]$ is the vector of parameter estimates. The vector and matrix functions, ξ and Ψ , are defined using two auxiliary equations:

$$\begin{aligned} \dot{\xi} = & (A_{22}(t) - LA_{12}(t))\xi \\ & + [(A_{21}(t) - LA_{11}(t) + (A_{22}(t) - LA_{12}(t) - \dot{L})y + g_2(t, u, y) - Lg_1(t, u, y))] \end{aligned} \quad (4.6)$$

$$\dot{\Psi} = (A_{22}(t) - LA_{12}(t))\Psi + [E_2(t, u, y) - LE_1(t, u, y)] \quad (4.7)$$

with $\Psi \in \mathfrak{R}^{(n-m) \times p}$ and $\xi \in \mathfrak{R}^{n-m}$. One filter is initialized to zero; the other to $\hat{x}_2(0)$; i.e.

$\Psi(0) = 0_{(n-m) \times p}$ and $\xi(0) = \hat{x}_2(0)$. The matrix L is selected such that the system

$\dot{z} = [A_{22}(t) - LA_{12}(t)]z$ is stable; when A_{22} and A_{12} are time-invariant, L is chosen to place the eigenvalues of $(A_{22} - LA_{12})$ in the open left hand plane.

A new observation typical of reduced-order filters is formed:

$$\bar{y} = \dot{y} - A_{11}(t)y - g_1(t, u, y) \quad (4.8)$$

(In the development of the reduced-order Kalman filter, this step results in an observation equation that contains noise, allowing the standard Kalman filter to be applied to the subsystem governing the unmeasured states.) This new equation is combined with (4.1) to yield another form of the new observation equation:

$$\bar{y} = A_{12}(t)x_2 + E_1(t, u, y)\theta \quad (4.9)$$

A parameter update law driven by the residual, $\bar{y} - \hat{\bar{y}}$, is prescribed:

$$\dot{\hat{\theta}} = \Phi_y(t, u, y)(\bar{y} - A_{12}\hat{x}_2 - E_1\hat{\theta}) \quad (4.10)$$

where

$$\Phi_y(t, u, y) = [\Psi'A'_{12} + E'_1] \quad (4.11)$$

At this point, were it not for the fact that \bar{y} depends on \dot{y} , the time derivative of the measurement, we would stop and the filter would be defined by equations (4.4) through (4.11). The \dot{y} term can be eliminated, however, if there exists a function $\phi(t, u, y)$ whose Jacobian matrix with respect to y is the matrix $\Phi_y(t, u, y)$ in (4.11):

$$\frac{\partial \phi_i}{\partial y_j} = \Phi_{y_j}$$

If such a function can be found, then by defining,

$$\hat{\theta} = \phi(t, u, y) + z_\theta \quad (4.12)$$

we see that

$$\dot{z}_\theta = \dot{\hat{\theta}} - \Phi_y(t, u, y)\dot{y} - \Phi_u(t, u, y)\dot{u} - \Phi_t(t, u, y) \quad (4.13)$$

Then the substitution of (4.8) and (4.10) into (4.13) produces the desired result, the elimination of \dot{y} ,

$$\begin{aligned} \dot{z}_\theta = & \Phi_y(t, u, y) \left(-A_{11}y - g_1(t, u, y) - A_{12}\hat{x}_2 - E_1\hat{\theta} \right) \\ & - \Phi_u(t, u, y)\dot{u} - \Phi_t(t, u, y) \end{aligned} \quad (4.14)$$

where $\Phi_u(t, u, y)$ and $\Phi_t(t, u, y)$ are the jacobians of $\phi(t)$ with respect to u and t , respectively. Thus, equations (4.12) and (4.14) can replace (4.10) and (4.8), thereby avoiding the use of \dot{y} . The ability to do this depends, of course, on the success one has in finding a suitable function $\phi(t, u, y)$ having the needed Jacobian matrix. If a suitable function cannot be found, then the user of this method would have to resort to the use of equations (4.10) and (4.8) involving \dot{y} .

The idea of using a reduced-order form to eliminate \dot{y} is used by Friedland in [16] to derive the reduced-order Kalman filter. Interestingly, the application of this technique here results in a parameter observer update law having the same form as the parameter

observer proposed by Friedland in [17] for nonlinear systems with full state feedback.

This is further discussed below.

4.1.3 Error Dynamics and Stability

The system dynamic equation (4.2) can be converted into a form with a stable

homogeneous part by adding and subtracting $LA_{12}x_2$:

$$\dot{x}_2 = A_{21}y + (A_{22} - LA_{12})x_2 + L(\bar{y} - E_1\theta) + g_2(t, u, y) + E_2\theta$$

which becomes, by equation (4.8):

$$\dot{x}_2 = (A_{22} - LA_{12})x_2 + (A_{21} - LA_{11})y + g_2(t, u, y) - Lg_1(t, u, y) + (E_2 - LE_1)\theta + Ly$$

Our desire is to express the state dynamics in terms of z , where $z = x_2 - Ly$, thus:

$$\begin{aligned} \dot{z} &= (A_{22} - LA_{12})z + [A_{21} - LA_{11} + (A_{22} - LA_{12})L - \dot{L}]y + g_2(t, u, y) \\ &\quad - Lg_1(t, u, y) + (E_2 - LE_1)\theta \end{aligned}$$

This is a non-homogeneous, linear vector differential equation with two driving terms, one that is solely a function of time t , and the other that depends on a time dependent matrix and the true parameter θ . Therefore $z(t)$ can be expressed as:

$$\begin{aligned} z(t) &= \Xi(t, 0)z(0) + \int_0^t \Xi(t, \tau) \left\{ [A_{21} - LA_{11} + (A_{22} - LA_{12})L - \dot{L}]y + g_2(\tau, u, y) - Lg_1(\tau, u, y) \right\} d\tau \\ &\quad + \int_0^t \Xi(t, \tau)(E_2 - LE_1)\theta d\tau \end{aligned}$$

where $\Xi(t, \tau)$ is the state transition matrix over $[\tau, t]$ for $A_{22} - LA_{12}$. It should be noted that when dealing with time-invariant systems, $\Xi(t, \tau) = e^{(A_{22} - LA_{12})(t - \tau)}$ and $\dot{L} = 0$.

So, by examining the above, one can see that the true $z(t)$, like the estimate $\hat{z}(t)$ in (4.5), can be written in terms of the auxiliary filter dynamics, (4.6) and (4.7), as follows:

$$z(t) = \Xi(t, 0)z(0) + \xi(t) + \Psi(t)\theta$$

The state observation error, $e_x = x_2 - \hat{x}_2$, given (4.5), is therefore:

$$\begin{aligned}
e_x &= z + Ly - \hat{z} - Ly \\
&= \Xi(t,0)z(0) + \Psi(t)e_\theta
\end{aligned} \tag{4.15}$$

where $e_\theta = \theta - \hat{\theta}$. Moreover, the parameter error dynamics as given by equation (4.10)

are

$$\dot{e}_\theta = -\Phi_y(t, u, y)(\bar{y} - A_{12}\hat{x}_2 - E_1\hat{\theta}) \tag{4.16}$$

Then, defining

$$\bar{C} = [A_{12} \quad E_1]$$

and

$$\bar{x} = [x'_2 \quad \theta']$$

we see by (4.9) that $\bar{y} = \bar{C}\bar{x}$, and that (4.16) can be expressed

$$\begin{aligned}
\dot{e}_\theta &= -\Phi_y(t, u, y)\bar{C}(\bar{x} - \hat{x}) \\
&= -\Phi_y(t, u, y)\bar{C} \begin{bmatrix} e_x \\ e_\theta \end{bmatrix}
\end{aligned}$$

Neglecting, for the moment, the exponentially stable initial condition term in (4.15), we

note that

$$\dot{e}_\theta = -\Phi_y(t, u, y)\bar{C} \begin{bmatrix} \Psi \\ I \end{bmatrix} e_\theta$$

However, by equation (4.11), this becomes

$$\dot{e}_\theta = -\begin{bmatrix} \Psi' & I \end{bmatrix} \begin{bmatrix} A'_{12} \\ E'_1 \end{bmatrix} [A_{12} \quad E_1] \begin{bmatrix} \Psi \\ I \end{bmatrix} e_\theta$$

which is equivalent to

$$\dot{e}_\theta = -\bar{\Psi}'\bar{C}'\bar{C}\bar{\Psi}e_\theta \tag{4.17}$$

with $\bar{\Psi} = [\Psi \quad I]$.

Proof of Stability The stability of the system requires persistency of excitation. This is assured if the following holds true. There must exist positive constants δ and

$0 < \alpha_1 < \alpha_2 < \infty$ such that for all $t \geq 0$:

$$\alpha_1 I \leq \int_t^{t+\delta} \bar{\Psi}'(\tau) \bar{C}'(\tau) \bar{C}(\tau) \bar{\Psi}(\tau) d\tau \leq \alpha_2 I$$

Then, by Theorem 2.5.1 of Sastry [41], $e_\theta \rightarrow 0$ as $t \rightarrow \infty$, globally, asymptotically, and exponentially.

As an alternative proof, one must show that:

$$J(t, t_0) = \int_{t_0}^t |\bar{\Psi}'(\tau) \bar{C}'(\tau) \bar{C}(\tau) \bar{\Psi}(\tau)| d\tau \quad \text{is nonsingular for all } t > t_0$$

$$\text{and } \lim_{t \rightarrow \infty} J(t, t_0) = \infty$$

Then, by Theorem 2-3 of Section 2.1.2, global, asymptotic stability of (4.17) is guaranteed, i.e. $e_\theta \rightarrow 0$ as $t \rightarrow \infty$. What then can be said about the state estimation error? Since $\Xi(t, \tau)$ is stable by assumption (or in the case of linear, time-invariant systems, $(A_{22} - LA_{12})$ is Hurwitz), the initial condition term in (4.15) decays exponentially to zero, leaving the second term. From (4.15) it follows that $e_x \rightarrow 0$ as $t \rightarrow \infty$ also. Thus, both the parameter and state observation errors converge to zero, globally and exponentially. \square

4.2 Nonlinear Reduced-Order Observer 2

Friedland's parameter observer for nonlinear dynamic systems with full state availability is extended to include systems with partial state availability. We begin by considering a general nonlinear system, and for it derive the nonlinear observer equations. Then, in order to illustrate the difficulty one encounters in generating a stability result when

dealing with general nonlinear systems, we consider the class of systems that are affine in the unknown parameter θ and involve nonlinearities that depend on the unknown state x_2 . Finally, these difficulties are avoided and a stability result is derived for the more restrictive system class, System Class A, which as stated earlier, is affine in a parameter θ and involves nonlinearities that depend only on the known quantities, t , y , and u . Like Friedland's original parameter observer, this new observer has very low computational overhead, the order of the filter equaling the number of unknown states and parameters, $(n - m + p)$.

4.2.1 Background

Friedland extends the linear, reduced-order observer

$$\begin{aligned}\hat{\theta} &= Kx + z \\ \dot{z} &= -K(Ax + Bu + E\hat{\theta})\end{aligned}$$

to nonlinear systems by replacing the linear gain term Kx by a nonlinear state dependent function $\phi(x)$ (see Sec. 3.1.3). This lead to a procedure for defining $\partial\phi(x)/\partial x$, the Jacobian of $\phi(x)$, such that the convergence of the parameter observer is assured, globally (assuming conditions of persistent excitation are satisfied and the system is affine in the unknown parameter vector). A important feature of Friedland's method is its low computational requirement. His parameter observer has order p , the number of unknown parameters. There are no other dynamic equations involved, unlike Narendra's observer which also involves an n^{th} order state filter, or any of the others which involve either auxiliary filters or covariance update equations.

4.2.2 General Observer Equations

Consider the following general nonlinear dynamic system with partial state available by direct measurement,

$$\begin{aligned}\dot{x}_1 &= f_1(x_1, x_2, u, \theta, t) \\ \dot{x}_2 &= f_2(x_1, x_2, u, \theta, t) \\ y &= x_1\end{aligned}$$

where $x_1 \in \mathfrak{R}^m$ is the measured substate, $y \in \mathfrak{R}^m$ the measurement, $x_2 \in \mathfrak{R}^{n-m}$ is the unmeasured substate, $u \in \mathfrak{R}^k$ the control, and $\theta \in \mathfrak{R}^p$ the unknown parameter vector.

Again we assume, without loss of generality, that the first m states are measured and the remaining $n-m$ are not. Following the approach taken by Friedland, we propose a reduced-order state observer with nonlinear gain $\kappa(y)$:

$$\begin{aligned}\hat{x}_2 &= \kappa(y) + z_x \\ \dot{z}_x &= \psi(y, \hat{x}_2, u, \hat{\theta})\end{aligned}$$

where \hat{x}_2 is the estimate of x_2 , $\kappa(y) : \mathfrak{R}^m \rightarrow \mathfrak{R}^{n-m}$ is a vector of arbitrary nonlinear functions of y , and $z_x \in \mathfrak{R}^{n-m}$ is a nonlinear vector function $\psi(\cdot)$, which is to be defined.

To estimate θ , an observer of similar form is proposed:

$$\begin{aligned}\hat{\theta} &= \phi(y) + z_\theta \\ \dot{z}_\theta &= \gamma(y, \hat{x}_2, u, \hat{\theta})\end{aligned}$$

where $\hat{\theta}$ is the estimate of θ , $\gamma(y) : \mathfrak{R}^m \rightarrow \mathfrak{R}^p$ is a vector of nonlinear functions of y , and $z_\theta \in \mathfrak{R}^p$ is a dynamic function of $\gamma(\cdot)$, also to be defined below.

The functions $\psi()$ and $\gamma()$ are to be defined such that the origin of the state and parameter error space is an equilibrium state. That is, $\dot{e} = 0$ when $e = 0$, where

$e = \begin{bmatrix} e'_x & e'_\theta \end{bmatrix}$. The state estimation error propagation is governed by

$$\begin{aligned} \dot{e}_x &= \dot{x} - \dot{\hat{x}} \\ &= f_2(y, x_2, u, \theta, t) - \left[\frac{\partial \kappa(y)}{\partial y} \right] f_1(y, x_2, u, \theta, t) - \psi(y, \hat{x}_2, u, \hat{\theta}, t) \end{aligned}$$

Setting $\psi() = f_2(y, \hat{x}_2, u, \hat{\theta}, t) - \left[\frac{\partial \kappa(y)}{\partial y} \right] f_1(y, \hat{x}_2, u, \hat{\theta}, t)$ allows the origin of the error

space to be an equilibrium. Then

$$\dot{e}_x = f_2(y, x_2, u, \theta, t) - f_2(y, \hat{x}_2, u, \hat{\theta}, t) - K(y) \left[f_1(y, x_2, u, \theta, t) - f_1(y, \hat{x}_2, u, \hat{\theta}, t) \right] \quad (4.18)$$

where $K(y) = \left[\frac{\partial \kappa_i(y)}{\partial y_j} \right]$, the jacobian of $\kappa(y)$.

Similarly, we note that the parameter estimation error is governed by

$$\begin{aligned} \dot{e}_\theta &= -\dot{\hat{\theta}} \\ &= - \left[\frac{\partial \phi(y)}{\partial y} \right] f_1(y, x_2, u, \theta, t) - \gamma(y, \hat{x}_2, u, \hat{\theta}, t) \end{aligned}$$

So, by setting $\gamma() = - \left[\frac{\partial \phi(y)}{\partial y} \right] f_1(y, \hat{x}_2, u, \hat{\theta}, t)$, we have

$$\dot{e}_\theta = -\Phi(y) \left[f_1(y, x_2, u, \theta, t) - f_1(y, \hat{x}_2, u, \hat{\theta}, t) \right] \quad (4.19)$$

where $\Phi(y) = \left[\frac{\partial \phi_i(y)}{\partial y_j} \right]$, the jacobian of $\phi(y)$. Here again, the origin is an equilibrium.

With these definitions for $\kappa(y)$ and $\phi(y)$, the state and parameter observer dynamic equations become:

$$\hat{x}_2 = \kappa(y) + z_x \quad (4.20)$$

$$\dot{z}_x = f_2(y, \hat{x}_2, u, \hat{\theta}, t) - K(y)f_1(y, \hat{x}_2, u, \hat{\theta}, t)$$

$$\hat{\theta} = \phi(y) + z_\theta \quad (4.21)$$

$$\dot{z}_\theta = -\Phi(y)f_1(y, \hat{x}_2, u, \hat{\theta}, t)$$

Functions $\kappa(y)$ and $\phi(y)$ are to be defined such that the convergence of the observer estimates to the true values is assured.

4.2.3 Error Dynamics for Systems Involving x_2 and θ

At this point we consider the somewhat more general class of nonlinear systems having the form:

$$\dot{x}_1(t) = A_{11}(t)x_1 + A_{12}(t)x_2 + B_1(t)u + E_1(y, u, t)\theta + g_1(y, u, t) + G_1(y, x_2, u, t)\theta \quad (4.22)$$

$$\dot{x}_2(t) = A_{21}(t)x_1 + A_{22}(t)x_2 + B_2(t)u + E_2(y, u, t)\theta + g_2(y, u, t) + G_2(y, x_2, u, t)\theta \quad (4.23)$$

which, unlike System Class A, involve nonlinear matrix functions

$G_1 : \mathfrak{R}^m \times \mathfrak{R}^{n-m} \times \mathfrak{R}^q \times \mathfrak{R}^+ \rightarrow \mathfrak{R}^{m \times p}$ and $G_2 : \mathfrak{R}^m \times \mathfrak{R}^{n-m} \times \mathfrak{R}^q \times \mathfrak{R}^+ \rightarrow \mathfrak{R}^{(n-m) \times p}$. They are

affine in the unknown parameter vector θ and depend in an arbitrary nonlinear way on the unknown substate x_2 . They are included here initially to show how they influence the error dynamics in a way that defies analysis. Then they are removed to permit analysis.

Substituting the state dynamic equations (4.22) and (4.23) into the error dynamics (4.18) and (4.19) result in the error equations:

$$\begin{aligned} \dot{e}_x &= A_{22}e_x + E_2(y, u, t)e_\theta + G_2(y, x_2, u, t)\theta - G_2(y, \hat{x}_2, u, t)\hat{\theta} \\ &\quad - K(y)\left[A_{12}e_x + E_1(y, u, t)e_\theta + G_1(y, x_2, u, t)\theta - G_1(y, \hat{x}_2, u, t)\hat{\theta}\right] \\ \dot{e}_\theta &= -\Phi(y)\left[A_{12}e_x + E_1(y, u, t)e_\theta + G_1(y, x_2, u, t)\theta - G_1(y, \hat{x}_2, u, t)\hat{\theta}\right] \end{aligned}$$

which in matrix form is:

$$\begin{bmatrix} \dot{e}_x \\ \dot{e}_\theta \end{bmatrix} = \begin{bmatrix} (A_{22} - K(y)A_{12}) & E_2 - K(y)E_1 \\ -\Phi(y)A_{12} & -\Phi(y)E_1 \end{bmatrix} \begin{bmatrix} e_x \\ e_\theta \end{bmatrix} + \begin{bmatrix} G_2(y, x_2, y, t)\theta - G_2(y, \hat{x}_2, u, t)\hat{\theta} - K(y)[G_1(y, x_2, u, t)\theta - G_1(y, \hat{x}_2, u, t)\hat{\theta}] \\ -\Phi(y)[G_1(y, x_2, u, t)\theta - G_1(y, \hat{x}_2, u, t)\hat{\theta}] \end{bmatrix} \quad (4.24)$$

where functional dependencies are eliminated except where necessary for clarity.

The second term in (4.24), involving the nonlinear terms $G_1()$ and $G_2()$, greatly complicates any analysis of stability that one would attempt for this system. In fact, were it not for the presence of $G_1()$ and $G_2()$, the error dynamics would be completely linear. Therefore, to avoid this problem, we further restrict the class of system to that defined in Chapter 1 as System Class A, which is repeated below.

4.2.4 Error Dynamics for System Class A

We again consider System Class A:

$$\dot{x}_1(t) = A_{11}(t)x_1 + A_{12}x_2 + B_1(t)u + E_1(y, u, t)\theta + g_1(y, u, t) \quad (4.25)$$

$$\dot{x}_2(t) = A_{21}(t)x_1 + A_{22}x_2 + B_2(t)u + E_2(y, u, t)\theta + g_2(y, u, t) \quad (4.26)$$

For this class of system, the observer error dynamics reduce to

$$\begin{bmatrix} \dot{e}_x \\ \dot{e}_\theta \end{bmatrix} = \begin{bmatrix} (A_{22} - KA_{12}) & E_2 - KE_1 \\ -\Phi A_{12} & -\Phi E_1 \end{bmatrix} \begin{bmatrix} e_x \\ e_\theta \end{bmatrix}$$

which is a linear, time-varying, homogeneous matrix differential equation and as such, much easier to handle analytically. The observer equations for this class of system are:

$$\begin{aligned} \hat{x}_2 &= \kappa(y) + z_x \\ \dot{z}_x &= A_{21}(t)y + A_{22}\hat{x}_2 + B_2(t)u + E_2(y, u, t)\hat{\theta} + g_2(y, u, t) \\ &\quad - K(y)[A_{11}(t)y + A_{12}(t)\hat{x}_2 + B_1(t)u + E_1(y, u, t)\hat{\theta} + g_1(y, u, t)] \end{aligned} \quad (4.27)$$

$$\begin{aligned}\hat{\theta} &= \phi(y) + z_\theta \\ \dot{z}_\theta &= -\Phi(y) \left[A_{11}(t)y + A_{12}(t)\hat{x}_2 + B_1(t)u + E_1(y, u, t)\hat{\theta} + g_1(y, u, t) \right]\end{aligned}\quad (4.28)$$

For the purpose of the following theorem, we define:

$$M(t) = \begin{bmatrix} KA_{12} & -E_2 + KE_1 \\ \Phi A_{12} & \Phi E_1 \end{bmatrix}\quad (4.29)$$

and

$$A = \begin{bmatrix} A_{22} & 0 \\ 0 & 0 \end{bmatrix}\quad (4.30)$$

That is, $\dot{e} = -Me + Ae$. We also assume that A_{22} is Hurwitz.

Theorem 4-1 – Given the nonlinear dynamic system (4.25) and (4.26) of System Class A, and the state and parameter observers (4.27) and (4.28), if functions $\kappa(y)$ and $\phi(y)$ can be selected such that $M(t)$ is a positive semi-definite symmetric matrix, then a sufficient condition for the convergence of the state and parameter errors is the existence of positive constants $0 < \alpha_1 < \alpha_2 < \infty$ such that for all $t \geq 0$:

$$\alpha_1 I \leq \int_t^{t+\delta} M(\tau) d\tau \leq \alpha_2 I\quad (4.31)$$

Proof Consider the candidate Lyapunov function,

$$V = e'Pe$$

where $e = \begin{bmatrix} e'_x & e'_\theta \end{bmatrix}$ and where P is a constant, symmetric, positive definite block diagonal matrix,

$$P = \begin{bmatrix} P_1 & 0 \\ 0 & P_2 \end{bmatrix}$$

partitioned in accordance with the dimensions of x_2 and θ ; that is P_1 is an $(n-m) \times (n-m)$ matrix and P_2 is an $p \times p$. The time derivative of V is

$$\frac{dV}{dt} = -e'(MP + PM)e + e'(A'P + PA)e \quad (4.32)$$

Since P is positive definite symmetric and M is positive semi-definite symmetric by design, the term $MP + PM$ will also be positive semi-definite and symmetric. Thus, the first term in (4.32) is a positive semi-definite symmetric matrix which we will designate $R(t)$. Also, given (4.31), clearly there exists two other positive constants $\bar{\alpha}_1$ and $\bar{\alpha}_2$, such that for all $t \geq 0$:

$$\bar{\alpha}_1 I \leq P \int_t^{t+\delta} M(\tau) d\tau + \int_t^{t+\delta} M(\tau) d\tau P \leq \bar{\alpha}_2 I \quad (4.33)$$

The second term can be simplified due to the block diagonal structure of P and A .

Defining

$$Q = \begin{bmatrix} Q_1 & 0 \\ 0 & Q_2 \end{bmatrix}$$

we have

$$A'_{22} P_1 + P_1 A_{22} = -Q_1$$

$$0 = Q_2$$

And since A_{22} is a fixed Hurwitz matrix, it will always be possible to find symmetric, positive-definite matrices P_1 and Q_1 . Thus,

$$\dot{V} = -e'R(t)e - e'Qe \leq 0$$

and therefore

$$\dot{V} \leq -e'R(t)e = -e'C'(t)C(t)e \leq 0$$

Moreover, $\dot{V} = 0$ for all t only when,

- (1) $e = 0$ for all t , or
- (2) $C(t)e = 0$ for all t ,

which is not possible if (4.33) holds. Thus, stability of the observer,(4.27) and (4.28), for the conditions noted is proved. \square

4.2.4.1 Design Procedure:

1. Choose $\Phi(y)$ and $K(y)$ such that $M(t)$ is both symmetric and positive semi-definite;

i.e.

- $\Phi(y)A_{12} = (-E_2(y, u, t) + KE_1(y, u, t))'$
- $K(y)A_{12} = A_{12}'K'(y)$ and
- $\Phi(y)E_1(y, u, t) = E_1'(y, u, t)\Phi'(y)$

2. Verify that (4.31) is satisfied.

3. Determine the vector functions $\phi(y)$ and $\kappa(y)$ having jacobians $\Phi(y)$ and $K(y)$.

This design procedure is illustrated in the following two examples.

4.2.4.2 Simulation Example One: Consider the simple, second order system with one unknown parameter:

$$\frac{y}{u} = \frac{1}{s(s + \theta)}$$

which, in the required form is:

$$\begin{bmatrix} \dot{x}_1 \\ \dot{x}_2 \end{bmatrix} = \begin{bmatrix} 0 & 1 \\ 0 & 0 \end{bmatrix} \begin{bmatrix} x_1 \\ x_2 \end{bmatrix} + \begin{bmatrix} -y \\ 0 \end{bmatrix} \theta + \begin{bmatrix} 0 \\ 1 \end{bmatrix} u$$

and $y = x_1$. The submatrices $A_{11} = A_{21} = A_{22} = 0$, $A_{12} = 1$, $E_1 = -y$, and $E_2 = 0$.

Following the design procedure stated above;

1. The time-varying matrix $M(t) = \begin{bmatrix} K(y) & -K(y)y \\ \Phi(y) & -\Phi(y)y \end{bmatrix}$, so to achieve symmetry and

positive semi-definiteness, set $K(y) = K$, where K is a constant, and set $\Phi(y) = -Ky$.

Then

$$M(t) = \begin{bmatrix} K & -Ky \\ -Ky & Ky^2 \end{bmatrix}$$

which is symmetric and positive semi-definite for any $K > 0$.

2. One can test if (4.31) is satisfied for any $y(t)$ and find that it is satisfied.

3. The following observer functions are identified as having the needed jacobians:

$$\kappa(y) = Ky$$

$$\phi(y) = -\frac{K}{2}y^2$$

Following (4.27) and (4.28), one finds that the observer equations are:

$$\dot{\hat{x}}_2 = Ky + z_x$$

$$\dot{z}_x = u - K[\hat{x}_2 - y\hat{\theta}]$$

$$\dot{\hat{\theta}} = -\frac{K}{2}y^2 + z_\theta$$

$$\dot{z}_\theta = Ky[\hat{x}_2 - y\hat{\theta}]$$

With all initial conditions of zero, a true parameter $\theta = 1$, and an observer gain $K = 1$, the simulation results shown below in Figure 4.1 show that the observer estimates converge to their true values.

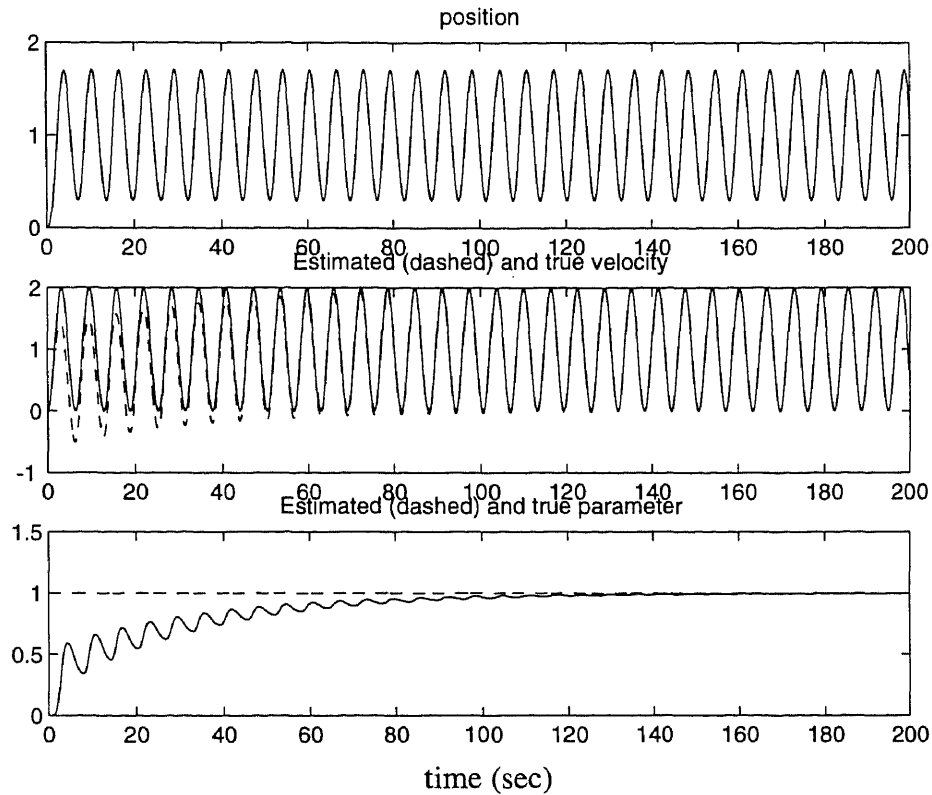

Figure 4.1 Simulation of Nonlinear Observer 2 in Simple 2nd Order Example

4.2.4.3 Simulation Example Two: In this example, we consider the third order system with two unknown parameters and two measurements:

$$\begin{bmatrix} \dot{x}_1 \\ \dot{x}_2 \\ \dot{x}_3 \end{bmatrix} = \begin{bmatrix} 0 & 1 & 0 \\ -\theta_1 & -\theta_2 & 1 \\ 0 & 0 & 0 \end{bmatrix} \begin{bmatrix} x_1 \\ x_2 \\ x_3 \end{bmatrix} + \begin{bmatrix} 0 \\ 0 \\ 1 \end{bmatrix} u \quad y = [x_1 \quad x_2]$$

which in required form is

$$\begin{bmatrix} \dot{x}_1 \\ \dot{x}_2 \\ \dot{x}_3 \end{bmatrix} = \begin{bmatrix} 0 & 1 & 0 \\ 0 & 0 & 1 \\ 0 & 0 & 0 \end{bmatrix} \begin{bmatrix} x_1 \\ x_2 \\ x_3 \end{bmatrix} + \begin{bmatrix} 0 & 0 \\ -y_1 & -y_2 \\ 0 & 0 \end{bmatrix} \begin{bmatrix} \theta_1 \\ \theta_2 \end{bmatrix} + \begin{bmatrix} 0 \\ 0 \\ 1 \end{bmatrix} u$$

Thus, we have the following submatrices

$$A_{11} = \begin{bmatrix} 0 & 1 \\ 0 & 0 \end{bmatrix} \quad A_{12} = \begin{bmatrix} 0 \\ 1 \end{bmatrix} \quad A_{21} = [0 \quad 0] \quad A_{22} = [0]$$

and,

$$E_1 = \begin{bmatrix} 0 & 0 \\ -y_1 & -y_2 \end{bmatrix} \quad E_2 = [0 \quad 0]$$

Given the dimensions of this problem:

$$K(y) = [K_1(y) \quad K_2(y)] \quad \Phi(y) = \begin{bmatrix} \Phi_{11}(y) & \Phi_{12}(y) \\ \Phi_{21}(y) & \Phi_{22}(y) \end{bmatrix}$$

thus, the matrix

$$M(t) = \begin{bmatrix} K_2(y) & -K_1(y)y_1 & -K_2(y)y_2 \\ \Phi_{12}(y) & -\Phi_{12}(y)y_1 & -\Phi_{12}(y)y_2 \\ \Phi_{22}(y) & -\Phi_{22}(y)y_1 & -\Phi_{22}(y)y_2 \end{bmatrix}.$$

Now, following the design process defined above;

1. To achieve a form for $M(t)$ that can be made symmetric, we let

$$K(y) = [K_1 \quad K_2] \quad \Phi(y) = \begin{bmatrix} L_1 y_2 & L_1 y_1 \\ 0 & L_2 y_2 \end{bmatrix}$$

where $K_1, K_2, L_1,$ and L_2 are constants. Then,

$$M(t) = \begin{bmatrix} K_2 & -K_1 y_1 & -K_2 y_2 \\ L_1 y_1 & -L_1 y_1^2 & -L_1 y_1 y_2 \\ L_2 y_2 & -L_2 y_1 y_2 & -L_2 y_2^2 \end{bmatrix}$$

which can be made symmetric by setting $L_1 = -K_1$ and $L_2 = -K_2$, such that

$$M(t) = \begin{bmatrix} K_2 & -K_1 y_1 & -K_2 y_2 \\ -K_1 y_1 & K_1 y_1^2 & K_1 y_1 y_2 \\ -K_2 y_2 & K_2 y_1 y_2 & K_2 y_2^2 \end{bmatrix}$$

The matrix $M(t)$ is then positive semi-definite for any $K_1 > 0$ and $K_2 > 0$.

2. One can test if (4.31) is satisfied for any $y(t)$ and find that it is satisfied.
3. Observer functions that are consistent with the jacobians $K(y)$ and $\Phi(y)$, were found:

$$\kappa(y) = K_1 y_1 + K_2 y_2$$

$$\phi(y) = \begin{bmatrix} -K_1 y_1 y_2 \\ -\frac{1}{2} K_2 y_2^2 \end{bmatrix}$$

and following (4.27) and (4.28), the observer equations are:

$$\begin{aligned} \hat{x}_3 &= K_1 y_1 + K_2 y_2 + z_x \\ \dot{z}_x &= u - [K_1 \quad K_2] \left\{ \begin{bmatrix} y_2 \\ 0 \end{bmatrix} + \begin{bmatrix} 0 \\ 1 \end{bmatrix} \hat{x}_3 + \begin{bmatrix} 0 \\ -y_1 \hat{\theta}_1 - y_2 \hat{\theta}_2 \end{bmatrix} \right\} \\ &= u - K_1 y_2 - K_2 (\hat{x}_3 - y_1 \hat{\theta}_1 - y_2 \hat{\theta}_2) \\ \hat{\theta} &= \begin{bmatrix} -K_1 y_1 y_2 \\ -\frac{1}{2} K_2 y_2^2 \end{bmatrix} + z_\theta \\ \dot{z}_\theta &= \begin{bmatrix} K_1 y_2 & K_1 y_1 \\ 0 & K_2 y_2 \end{bmatrix} \left\{ \begin{bmatrix} y_2 \\ 0 \end{bmatrix} + \begin{bmatrix} 0 \\ \hat{x}_3 - y_1 \hat{\theta}_1 - y_2 \hat{\theta}_2 \end{bmatrix} \right\} \\ &= \begin{bmatrix} K_1 y_2^2 + K_1 y_1 (\hat{x}_3 - y_1 \hat{\theta}_1 - y_2 \hat{\theta}_2) \\ K_2 y_2 (\hat{x}_3 - y_1 \hat{\theta}_1 - y_2 \hat{\theta}_2) \end{bmatrix} \end{aligned}$$

With observer gains $K_1 = K_2 = 1$, initial conditions

$$x_1(0) = x_2(0) = x_3(0) = 0 \quad \hat{x}_1(0) = 1 \quad \hat{x}_2(0) = \hat{x}_3(0) = 0$$

true parameters $\theta_1 = 1$ and $\theta_2 = 0.1$, initial parameter estimates $\hat{\theta}_1 = 0$ and $\hat{\theta}_2 = 0$, and probing input $u = \sin(t/2) + 10\sin(3t)$, the observer performs as shown below in Figure 4.2. Note that the observer estimates converge to their true values.

4.2.5 Comparison of the Non-Riccati Equation Based Methods

Nonlinear Observers 1 and 2 are both extensions to Friedland's method for parameter estimation in nonlinear systems with full state availability [17]. Comparison of the two reveals that their parameter update laws are identical. One can see this by comparing

equation (4.28) to equations (4.12)-(4.14). They are also identical to Friedland's in [17] except for the appearance of the estimated state \hat{x}_2 . The state update laws, however, are different, as can be seen by comparing (4.27) to (4.4)-(4.7). A closer examination of these differences is potential an area of future research.

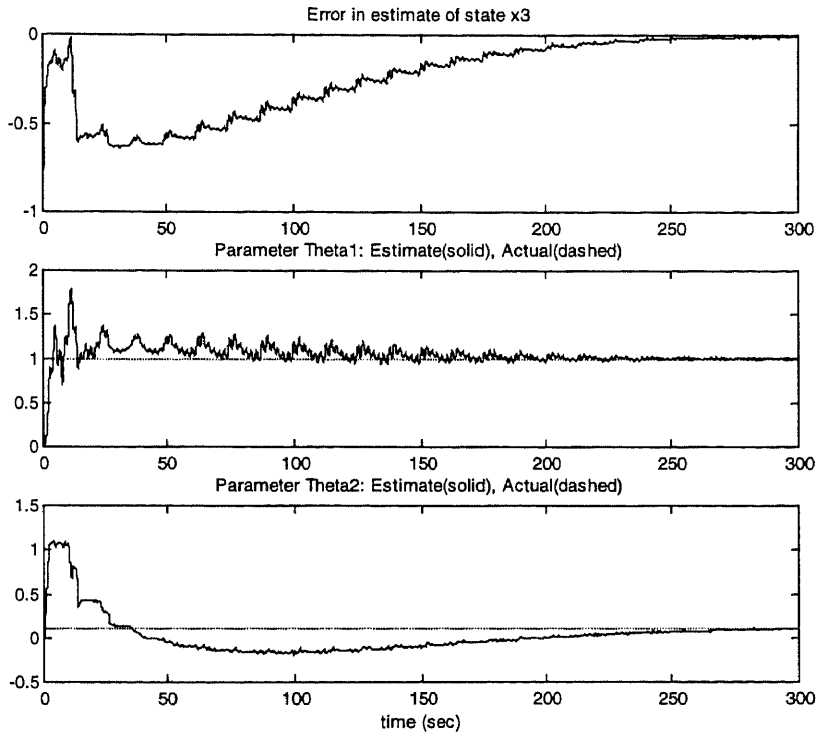

Figure 4.2 Simulation of Nonlinear Observer 2 in 3rd Order Example

4.3 Separate-Bias Reduced-Order Kalman Filter

In this section the optimal two-stage Kalman filter for linear systems that involve noise-free observations and constant, unknown bias is derived. This new filter consists of two uncoupled filters running in parallel, one providing an estimate of the bias vector, and one an estimate of the unmeasured state vector. The absence of measurement noise results in a reduction in the order of the state estimator, the order equaling the number of

states less the number of observations. Like the full-order separate-bias Kalman filter developed in 1969 [11], this new filter offers the same potential for improved numerical accuracy and reduced computational burden over the centralized Kalman filter arising with state augmentation. In Section 4.3.3, this new filter is applied to the problem of state and parameter estimation.

4.3.1 System Class

The problem under consideration is that of simultaneously estimating the state x and bias vector b of a linear process

$$\dot{x} = Ax + Bu + Eb + F\xi \quad (4.34)$$

with observations

$$y = Cx \quad (4.35)$$

where $x \in \mathfrak{R}^n$ is the state vector, $b \in \mathfrak{R}^p$ is a vector of constant but unknown biases, $u \in \mathfrak{R}^k$ is the control vector, $y \in \mathfrak{R}^m$ is the measurement vector, ξ is a white gaussian noise process with spectral density matrix Q , and where A , B , C , D , E , and F are coefficient matrices, possibly time-varying. It will be assumed that the states are arranged such that the first m are directly measured and the remaining $n-m$ are not measured at all; ie. $C = [I \ 0]$ and $x = \{x'_1 \ x'_2\}'$. The more general observation equation

$$y = Cx + Db$$

can be accommodated by converting to the assumed form (4.35) by a simple coordinate transformation of the form $z = Tx$.

4.3.2 Filter Equations

The separate-bias reduced-order Kalman filter developed herein is presented below in its entirety in equations (4.36) through (4.50), and is shown in block diagram form in Figure 4.3. The initial state and bias estimates and covariances are given by $\hat{x}(0)$, $\hat{b}(0)$, $P_x(0)$, and $P_b(0)$, respectively. The bias is assumed to be constant and governed by the equation $\dot{b} = 0$. The matrices A_{ij} , B_i , E_i , and F_i are the submatrices of (4.34), partitioned in accordance with the dimensions of x_1 and x_2 . The process noise ξ is a zero mean, white gaussian noise process with covariance $E\{\xi(t)\xi'(\tau)\} = Q\delta(t - \tau)$.

Optimal State Estimates:

$$\hat{x}_1 = y \quad (4.36)$$

$$\hat{x}_2 = \tilde{x}_2 + S\hat{b} \quad (4.37)$$

Bias-Free Filter:

$$\tilde{x}_2 = \tilde{z} + \tilde{K}y \quad (4.38)$$

$$\dot{\tilde{z}} = (A_{22} - \tilde{K}A_{12})\tilde{x}_2 + (A_{21} - \tilde{K}A_{11})y + (B_2 - \tilde{K}B_1)u - \dot{\tilde{K}}y \quad (4.39)$$

$$\tilde{z}(0) = \hat{x}_2(0)$$

$$\tilde{K} = (\tilde{P}_x A'_{12} + F_2 Q F'_1) W^{-1} \quad (4.40)$$

$$\dot{\tilde{P}}_x = \tilde{A}_{11} \tilde{P}_x + \tilde{P}_x \tilde{A}'_{11} - \tilde{P}_x A'_{12} W^{-1} A_{12} \tilde{P}_x + F_2 \tilde{Q} F'_2, \quad \tilde{P}_x(0) = P_x(0) \quad (4.41)$$

$$\tilde{A}_{11} = A_{22} - F_2 Q F'_1 W^{-1} A_{12} \quad (4.42)$$

$$\tilde{A}_{12} = E_2 - F_2 Q F'_1 W^{-1} \quad (4.43)$$

$$\tilde{Q} = Q - Q F_1 W F'_1 Q \quad (4.44)$$

$$W = F_1 Q F'_1 \quad (4.45)$$

Separate-Bias Filter:

$$\hat{b} = z_2 + K_2 y \quad (4.46)$$

$$\dot{z}_2 = -K_2 [A_{12} \tilde{x}_2 + (E_1 + A_{12} S) \hat{b} + A_{11} y + B_1 u] - \dot{K}_2 y, \quad z_2(0) = \hat{b}(0) \quad (4.47)$$

$$K_2 = M(S'A'_{12} + E'_1)W^{-1} \quad (4.48)$$

$$\dot{M} = -M(S'A'_{12} + E'_1)W^{-1}(A_{12}S + E_1)M, \quad M(0) = P_b(0) \quad (4.49)$$

$$\dot{S} = (A_{22} - \tilde{K}A_{12})S + (E_2 - \tilde{K}E_1), \quad S(0) = 0 \quad (4.50)$$

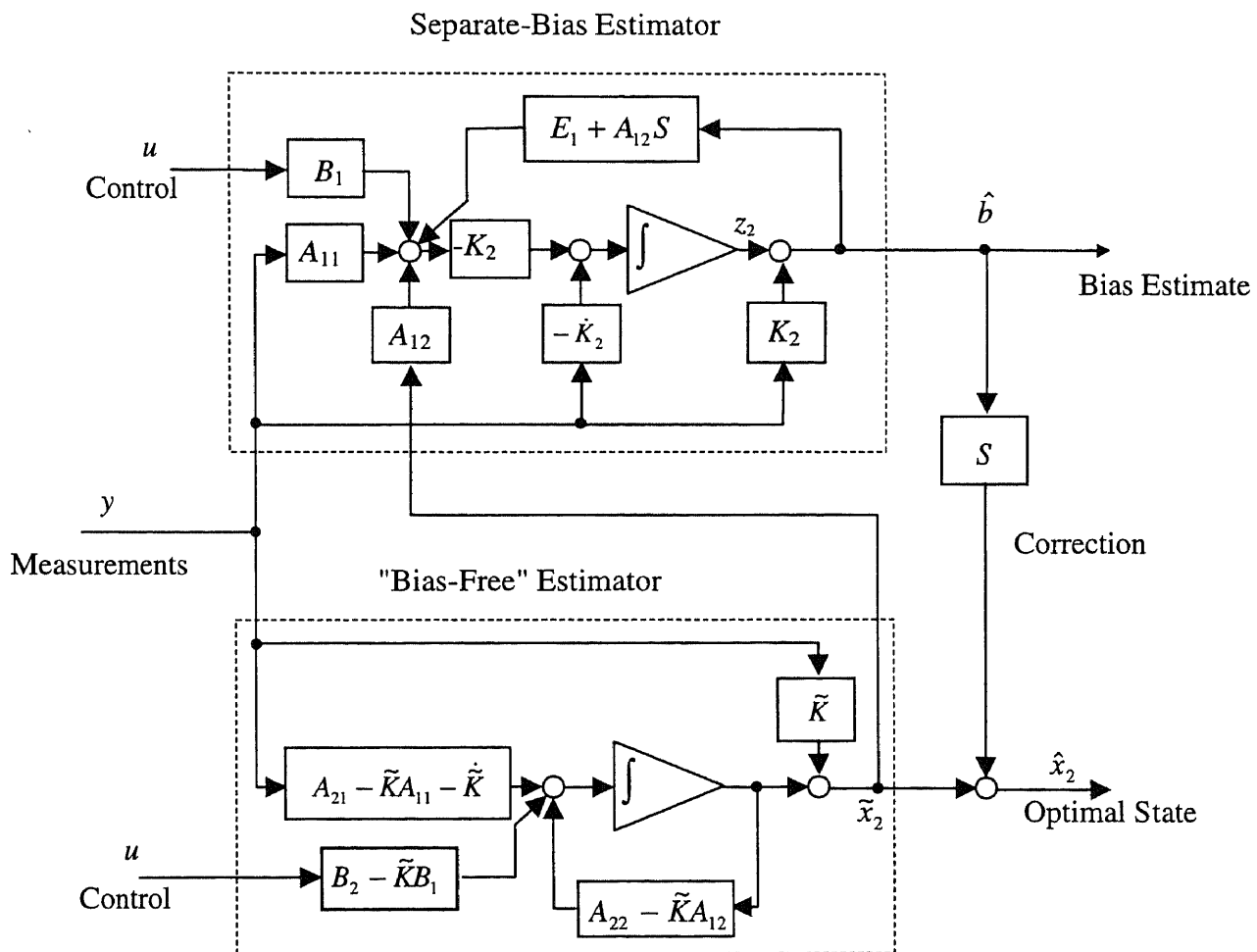

Figure 4.3 Separate-Bias Reduced-Order Kalman Filter

Theorem 4-2 – The optimal filter in separate-bias form for the linear system governed by equations (4.34)-(4.35), and driven by zero mean, white gaussian process noise ξ having spectral density Q , is that given by (4.36)-(4.50). If the system state variables and biases are all observable, so that Theorem 2-4 holds, then the global asymptotic convergence of the filter estimates to the true values is assured.

Proof It has long been known that the optimal filter for the linear dynamic system (4.34) having measurements that are free of noise is the reduced-order Kalman filter [15]. In the remainder of this section the reduced-order Kalman filter is converted to an equivalent separate-bias form. This equivalence therefore guarantees that it is both optimal and globally convergent, as is its progenitor. \square

Derivation of the Coupled Filtering Equations This development begins with the application of the reduced-order Kalman filter to a system with unknown bias. First, the state vector of the system, (4.34) and (4.35), is partitioned into directly measured and unmeasured substates:

$$\begin{bmatrix} \dot{x}_1 \\ \dot{x}_2 \end{bmatrix} = \begin{bmatrix} A_{11} & A_{12} \\ A_{21} & A_{22} \end{bmatrix} \begin{bmatrix} x_1 \\ x_2 \end{bmatrix} + \begin{bmatrix} B_1 \\ B_2 \end{bmatrix} u + \begin{bmatrix} E_1 \\ E_2 \end{bmatrix} b + \begin{bmatrix} F_1 \\ F_2 \end{bmatrix} \xi \quad (4.51)$$

$$y = x_1 \quad (4.52)$$

(The more general observation equation, (4.35), can be converted into this simpler form (4.52) by defining a new substate \tilde{x}_1 and applying the change in variable

$y = \tilde{x}_1 = Cx + Db$ to both (4.34) and (4.35).) The bias vector b is then appended to the

state vector of (4.51) to form the new state vector, $\{x'_1 \quad x'_2 \quad b'\}'$.

In accordance with the reduced-order filter given in Section 2.3, we define the sub-vector of unmeasured states \bar{x}_2 to contain the unmeasured dynamic states x_2 and the unknown bias vector b ,

$$\bar{x}_2 = \begin{bmatrix} x_2 \\ b \end{bmatrix}$$

and the sub-vector of directly measured states \bar{x}_1 is to contain only x_1 . Equation (4.51)

then becomes

$$\begin{bmatrix} \dot{x}_1 \\ \dot{x}_2 \\ \dot{b} \end{bmatrix} = \begin{bmatrix} A_{11} & A_{12} & E_1 \\ A_{21} & A_{22} & E_2 \\ 0 & 0 & 0 \end{bmatrix} \begin{bmatrix} x_1 \\ x_2 \\ b \end{bmatrix} + \begin{bmatrix} B_1 \\ B_2 \\ 0 \end{bmatrix} u + \begin{bmatrix} F_1 \\ F_2 \\ 0 \end{bmatrix} \xi \quad (4.53)$$

where use has been made of the bias dynamic equation, $\dot{b} = 0$. So by comparing (4.53)

with (2.23), one identifies the following submatrices:

$$\begin{aligned} \bar{A}_{11} &= A_{11} & \bar{A}_{12} &= [A_{12} \quad E_1] & \bar{B}_1 &= B_1 & \bar{F}_1 &= F \\ \bar{A}_{21} &= \begin{bmatrix} A_{21} \\ 0 \end{bmatrix} & \bar{A}_{22} &= \begin{bmatrix} A_{22} & E_2 \\ 0 & 0 \end{bmatrix} & \bar{B}_2 &= \begin{bmatrix} B_2 \\ 0 \end{bmatrix} & \bar{F}_2 &= \begin{bmatrix} F_2 \\ 0 \end{bmatrix} \end{aligned} \quad (4.54)$$

These, when substituted into the general reduced-order Kalman filtering equations (2.24)

–(2.26), yield the following coupled state update equations:

$$\hat{x}_1 = y \quad (4.55)$$

$$\hat{x}_2 = z_1 + K_1 y \quad (4.56)$$

$$\hat{b} = z_2 + K_2 y \quad (4.57)$$

$$\begin{aligned} \dot{z}_1 &= (A_{22} - K_1 A_{12}) \hat{x}_2 + (E_2 - K_1 E_1) \hat{b} + (A_{21} - K_1 A_{11}) y \\ &\quad + (B_2 - K_1 B_1) u - \dot{K}_1 y \end{aligned} \quad (4.58)$$

$$\dot{z}_2 = -K_2 (A_{12} \hat{x}_2 + E_1 \hat{b} + A_{11} y + B_1 u) - \dot{K}_2 y \quad (4.59)$$

Note that the gain matrix K given by (2.27), its time derivative \dot{K} , and vector z of (2.26) are partitioned accordingly:

$$K = \begin{bmatrix} K_1 \\ K_2 \end{bmatrix} \quad \dot{K} = \begin{bmatrix} \dot{K}_1 \\ \dot{K}_2 \end{bmatrix} \quad z = \begin{bmatrix} z_1 \\ z_2 \end{bmatrix}$$

A similar approach is taken to derive the coupled covariance update equations. The matrix P of (2.28) is partitioned in accordance with the substates contained in \bar{x}_2 as follows:

$$P = \begin{bmatrix} P_x & P_{xb} \\ P'_{xb} & P_b \end{bmatrix}$$

where

- P_x autocovariance of estimate of state x_2
- P_b autocovariance of estimate of bias b
- P_{xb} cross covariance of x_2 and b

Using the submatrices (4.54) and the covariance matrix equation (2.28) we derive:

$$\dot{P}_x = \tilde{A}_{11} P_x + \tilde{A}_{12} P'_{xb} + P_x \tilde{A}'_{11} + P_{xb} \tilde{A}'_{12} \quad (4.60)$$

$$- (P_x A'_{12} + P_{xb} E'_1) W^{-1} (A_{12} P_x + E_1 P'_{xb}) + F_2 \tilde{Q} F'_2$$

$$\dot{P}_{xb} = \tilde{A}_{11} P_{xb} + \tilde{A}_{12} P_b - (P_x A'_{12} + P_{xb} E'_1) W^{-1} (A_{12} P_{xb} + E_1 P_b) \quad (4.61)$$

$$\dot{P}_b = - (P'_{xb} A'_{12} + P_b E'_1) W^{-1} (A_{12} P_{xb} + E_1 P_b) \quad (4.62)$$

where

$$\tilde{A}_{11} = A_{22} - F_2 Q F'_1 W^{-1} A_{12} \quad (4.63)$$

$$\tilde{A}_{12} = E_2 - F_2 Q F'_1 W^{-1} \quad (4.64)$$

$$\tilde{Q} = Q - Q F_1 W F'_1 Q \quad (4.65)$$

Similarly, the partitioned Kalman matrices in (4.56) and (4.57) are derived by expanding (2.27):

$$K_1 = (P_x A'_{12} + P_{xb} E'_1 + F_2 Q F'_1) W^{-1} \quad (4.66)$$

$$K_2 = (P'_{xb} A'_{12} + P_b E'_1) W^{-1} \quad (4.67)$$

where

$$W = F_1 Q F'_1 \quad (4.68)$$

which completes the derivation of the coupled state and covariance equations. In this coupled form, the reduced-order Kalman filter for systems with bias offers no advantage over the centralized reduced-order Kalman filter from which it was derived. The claimed improvement in numerical stability and computational efficiency is achieved by casting this filter into the separate-bias form, which thereby eliminates the coupling. This is done below.

The “Bias-Free” State Estimator It is noted that (4.61) and (4.62) together are homogeneous in P_{xb} and P_b . Hence, if

$$P_{xb}(0) = 0 \quad P_b(0) = 0$$

then

$$P_{xb} \equiv 0 \quad P_b \equiv 0 \quad (4.69)$$

for $t > 0$, and hence P_x satisfies

$$\dot{\tilde{P}}_x = \tilde{A}_{11} \tilde{P}_x + \tilde{P}_x \tilde{A}'_{11} - \tilde{P}_x A'_{12} W^{-1} A_{12} \tilde{P}_x + F_2 \tilde{Q} F'_2 \quad (4.70)$$

The interpretation of (4.69) and (4.70) is that if the bias b is perfectly known at $t = 0$, then by virtue of $\dot{b} = 0$, it is perfectly known thereafter and the estimation problem reduces to that in which there is no bias. The bias-free estimator is therefore the reduced-order Kalman filter, (4.56), (4.58), and (4.66) with the simplifications that result when $\hat{b} = 0$, $P_b = 0$ and $P_{xb} = 0$:

$$\tilde{x}_2 = \tilde{z} + \tilde{K}y \quad (4.71)$$

$$\dot{\tilde{z}} = (A_{22} - \tilde{K}A_{12})\tilde{x}_2 + (A_{21} - \tilde{K}A_{11})y + (B_2 - \tilde{K}B_1)u - \dot{\tilde{K}}y \quad (4.72)$$

$$\tilde{K} = (\tilde{P}_x A'_{12} + F_2 Q F'_1) W^{-1} \quad (4.73)$$

(Wiggles (\sim) rather than hats (\wedge) are used to denote the new variables of the “bias-free” filter.)

The State Transformation As in the case of the full-order separate-bias Kalman filter, we introduce the transformation:

$$\hat{x}_2 = \tilde{x}_2 + S\hat{b} \quad (4.74)$$

where \tilde{x}_2 is the estimate of x_2 if no bias were present. The matrix S is to be determined such that this relationship (4.74) holds. To this end, we substitute into (4.74) equations (4.56), (4.57), and (4.71), yielding

$$z_1 + K_1 y = \tilde{z} + \tilde{K}y + S(z_2 + K_2 y) \quad (4.75)$$

For this expression to hold for all y independent of the estimator states z_1 , z_2 , and \tilde{z} , the terms multiplying y must cancel, thus

$$K_1 = \tilde{K} + SK_2 \quad (4.76)$$

which leaves

$$z_1 = \tilde{z} + Sz_2 \quad (4.77)$$

In order for (4.76) and (4.77) to hold we must have

$$\dot{K}_1 = \dot{\tilde{K}} + \dot{S}K_2 + S\dot{K}_2 \quad (4.78)$$

$$\dot{z}_1 = \dot{\tilde{z}} + \dot{S}z_2 + S\dot{z}_2 \quad (4.79)$$

Into this last equation we substitute equations (4.58), (4.59) and (4.72). Then, using equations (4.76), (4.78), and (4.57) to simplify the result yields,

$$\left[(A_{22} - K_1 A_{12})S + (E_2 - K_1 E_1) + SK_2(A_{12}S + E_1) - \dot{S} \right] \hat{b} = 0$$

Finally, using (4.76) to eliminate K_1 results in

$$\left[(A_{22} - \tilde{K}A_{12})S + (E_2 - \tilde{K}E_1) - \dot{S} \right] \hat{b} = 0$$

which is satisfied when

$$\dot{S} = (A_{22} - \tilde{K}A_{12})S + (E_2 - \tilde{K}E_1) \quad (4.80)$$

Thus, when S is computed using (4.80), the transformation equation relating \hat{x}_2 to \tilde{x}_2 and \hat{b} holds true. The initial condition on S is to be determined to satisfy a condition derived below.

The Separate-Bias Estimator The dependence of the separate-bias estimator on the optimal state estimate \hat{x}_2 is eliminated by substituting (4.74) into (4.59), yielding

$$\dot{z}_2 = -K_2 \left[A_{12} \tilde{x}_2 + (E_1 + A_{12}S) \hat{b} + A_{11}y + B_1u \right] - \dot{K}_2 y \quad (4.81)$$

You will note that the Separate-Bias Estimator depends on the known input u , feedback of \hat{b} , and on y and \tilde{x}_2 , which is to be expected. In the full-order case, the input to the separate-bias estimator is the residual of the “bias-free” estimator [16]. Since there is no residual in a reduced-order filter, both the measurement y and the “bias-free” estimator output \tilde{x}_2 , which together are somewhat equivalent to the “bias-free” residual, serve as inputs to the separate-bias estimator.

Decoupling of the Variance Equations The covariance P , defined originally by (2.28) and in partitioned form by (4.60)-(4.62) is expressed in terms of the covariance \tilde{P} that applies when the bias is known, plus a correction which depends on the covariance of the bias estimate P_b . The covariance matrix that applies when the bias is perfectly known is to be denoted by

$$\tilde{P} = \begin{bmatrix} \tilde{P}_x & 0 \\ 0 & 0 \end{bmatrix} \quad (4.82)$$

where \tilde{P}_x is the solution to (4.60) with $\tilde{P}_x(0)$ given. It is noted that \tilde{P} is also the solution to (2.28) when

$$\tilde{P}(0) = \begin{bmatrix} \tilde{P}_x(0) & 0 \\ 0 & 0 \end{bmatrix} \quad (4.83)$$

If the bias is not perfectly known, however, (4.83) is not the correct initial condition.

Instead the initial covariance will be

$$\tilde{P}(0) = \begin{bmatrix} \tilde{P}_x(0) & \tilde{P}_{xb}(0) \\ \tilde{P}'_{xb}(0) & \tilde{P}_b(0) \end{bmatrix} \quad (4.84)$$

where $\tilde{P}_b(0) \neq 0$ and $\tilde{P}_{xb}(0)$ may or may not be zero. The question is how much \tilde{P}_x , \tilde{P}_{xb} , and \tilde{P}_b change as the result of changing the initial conditions from (4.82) to (4.84)? This is answered by making use of the fact that if \tilde{P} is a solution to (2.28) then any other solution can be expressed as follows [13].

$$P = \tilde{P} + VMV' \quad (4.85)$$

where

$$\dot{V} = (\tilde{A} - \tilde{P}\bar{A}'_{12}W^{-1}\bar{A}_{12})V \quad (4.86)$$

$$\dot{M} = -MV\bar{A}'_{12}W^{-1}\bar{A}_{12}VM \quad (4.87)$$

The coupling matrix is partitioned in accordance with the size of x_2 and b :

$$V = \begin{bmatrix} V_x \\ V_b \end{bmatrix} \quad (4.88)$$

By partitioning (4.86) accordingly, and substituting in the definitions of \tilde{A} given by (2.29) and of \bar{A}_{12} and \bar{A}_{22} in (4.54), one finds

$$\begin{aligned} \dot{V}_x &= (A_{22} - F_2 Q F_1' W^{-1} A_{12} - \tilde{P}_x A_{12}' W^{-1} A_{12}) V_x \\ &\quad + (E_2 - F_2 Q F_1' W^{-1} E_1 - \tilde{P}_x A_{12}' W^{-1} E_1) V_b \end{aligned} \quad (4.89)$$

$$\dot{V}_b = 0 \quad \text{i.e.,} \quad V_b = \text{constant} \quad (4.90)$$

Similarly, (4.87) becomes

$$\dot{M} = -M(V_x' A_{12}' + V_b' E_1') W^{-1} (A_{12} V_x + E_1 V_b) M \quad (4.91)$$

Furthermore, the submatrices of (4.85) can be computed as follows:

$$\begin{aligned} P_x &= \tilde{P}_x + V_x M V_x' \\ P_{xb} &= V_x M V_b' \\ P_b &= V_b M V_b' \end{aligned} \quad (4.92)$$

Hence, it is possible to avoid the solution of the mutually coupled equations (4.60)-(4.62)

to determine P_x , P_b , and P_{xb} . Instead, one need only compute \tilde{P}_x , V_x , V_b , and M , using the equations which are not mutually coupled, (4.70), (4.86), (4.90), and (4.87), and use these results in (4.92).

The initial conditions $V_x(0)$, $V_b(0)$, and $M(0)$ of (4.89)-(4.91) must be properly selected to satisfy

$$\begin{aligned} P_x(0) - \tilde{P}_x(0) &= V_x(0) M(0) V_x'(0) = 0 \\ P_{xb}(0) &= V_x(0) M(0) V_b'(0) \\ P_b(0) &= V_b(0) M(0) V_b'(0) \end{aligned}$$

These initial conditions are not unique. For the important special case in which $P_{xb}(0) = 0$, i.e. when there is no *a priori* correlation between the state and bias, one choice of initial conditions is

$$\begin{aligned}
M(0) &= P_b(0) \\
V_x(0) &= 0 \\
V_b(0) &= I.
\end{aligned} \tag{4.93}$$

In this case $V_b = I$ for all $t > 0$, and

$$\begin{aligned}
P_{xb} &= V_x M \\
P_b &= M.
\end{aligned} \tag{4.94}$$

Now, upon use of (4.72) and (4.93) one finds that (4.89) reduces to

$$\dot{V}_x = (A_{22} - \tilde{K}A_{12})V_x + (E_2 - \tilde{K}E_1) \tag{4.95}$$

Similarly, (4.91) and (4.67) become

$$\dot{M} = -M(V_x'A'_{12} + E'_1)W^{-1}(A_{12}V_x + E_1)M \tag{4.96}$$

$$K_2 = M(V_x'A'_{12} + E'_1)W^{-1} \tag{4.97}$$

Note that equation (4.95) is the same as the matrix differential equation (4.80) governing S . Hence, by setting $S(0) = V_x(0) = 0$, we have $S \equiv V_x$ for all time. This simultaneously satisfies the state transformation relationship (4.74) and the variance transformation equations given by (4.93)-(4.97).

Steady-State Observer In certain applications the accuracy and complexity of the time-varying Kalman filter may not be needed, and in its place a steady-state observer may suffice. The steady-state separate-bias reduced order observer has the same structure as that shown in Figure 4.3; however, the Kalman gain matrices, \tilde{K} and K_2 , are replaced by constant matrices determined in some other way, e.g. pole placement. The bias correction matrix S of (4.80) then becomes a constant matrix given by:

$$S = -(A_{22} - \tilde{K}A_{12})^{-1}(E_2 - \tilde{K}E_1)$$

4.3.3 Application to State and Parameter Estimation

Equations (4.34)-(4.35), the system for which the Separate-bias Reduced-order Kalman filter was developed, are equivalent to the nonlinear system class identified in Section 1.2 as System Class B;

$$\begin{aligned}\dot{x}(t) &= A(t)x(t) + B(t)u(t) + E(t, y, u, \theta) \mathcal{G}(t) + g(t, y, u) + F(t)w \\ y(t) &= C(t)x(t)\end{aligned}$$

Thus, this new method can be readily applied to the problem of simultaneous state and parameter estimation in problems of System Class B. The unknown parameter vector θ is simply interpreted as a bias.

4.4 SDARE State and Parameter Observer

The State Dependent Algebraic Riccati Equation (SDARE) method developed by Mracek, et.al. [32] is applied in this section to the problem of simultaneous state and parameter estimation. Although conditions for the convergence of the filter have not been determined, the method has proven to work quite well when simulation tested in several examples involving lower order, nonlinear systems, including some from System Class C. However, as the number of unknown parameters increases beyond two, the requirement for the observability of the pair $[A(\hat{x}), C(\hat{x})]$ at each \hat{x} along the trajectory $\hat{x}(\tau) : t_0 \leq \tau \leq t$, as needed to generate filter gains, becomes difficult to meet. This has led us to conclude, therefore, that the SDARE method is best suited for state and parameter estimation problems when only two or three unknown parameters are involved. In addition, it has prompted the development of a nonlinear filter which is similar to the

SDARE filter in that it involves a state dependent Riccati equation, but differs in that it avoids the need for state and parameter observability at each instant in time.

System Class The SDARE method defined by (2.36)-(2.38) can be applied directly to general nonlinear systems expressed here in State Dependent Coefficient form:

$$\dot{x} = A(x, u)x + E(x, u)\theta + w \quad (4.98)$$

$$y = H(x, u)x + C(x, u)\theta + v \quad (4.99)$$

4.4.1 Filter Equations

To develop the SDARE filter for simultaneous state and parameter estimation we use the common approach of state augmentation. The parameters are assumed to evolve in accordance with

$$\dot{\theta} = \beta \quad (4.100)$$

where β is gaussian zero mean white noise with $E[\beta(t)\beta'(t+\tau)] = W_\theta(t)\delta(t-\tau)$. The SDARE filter then estimates the parameters as well as the state, assuming that conditions of observability and controllability (discussed below) are satisfied in the augmented system.

Adjoining θ to x yields a state vector of $n+p$ components,

$$\underline{x} = \begin{bmatrix} x \\ \theta \end{bmatrix} \quad (4.101)$$

Equations (4.98)-(4.99) can be then be written in compact form:

$$\dot{\underline{x}} = F(x)\underline{x} + w_a \quad (4.102)$$

$$y = H_a(x)\underline{x} + v \quad (4.103)$$

where

$$F(x) = \begin{bmatrix} A(x) & E(x) \\ 0 & 0 \end{bmatrix} \quad w_a = \begin{bmatrix} w \\ \beta \end{bmatrix} \quad H_a(x) = [H(x) \quad C(x)] \quad (4.104)$$

and where dependence on u is not shown for clarity. In addition we define

$E[w(t)w'(t+\tau)] = W_x(t)\delta(t-\tau)$, $E[v(t)v'(t+\tau)] = V(t)\delta(t-\tau)$, and further define

$$W_a = \begin{bmatrix} W_x & 0 \\ 0 & W_\theta \end{bmatrix} \quad (4.105)$$

(Although the true parameters may be constant, the spectral density W_θ used in the design of the filter must be nonzero with rank p , otherwise the filter gains associated with some elements of θ will be zero.)

Application of the SDARE method to this system results in filter equations,

$$\dot{\hat{x}} = A(\hat{x})\hat{x} + B(\hat{x})\hat{\theta} + K_x(\hat{x})[y - H(\hat{x})\hat{x} - C(\hat{x})\hat{\theta}] \quad (4.106)$$

$$\dot{\hat{\theta}} = K_\theta(\hat{x})[y - H(\hat{x})\hat{x} - C(\hat{x})\hat{\theta}] \quad (4.107)$$

where the filter gain matrix has been partitioned as follows:

$$K_f(\hat{x}) = \begin{bmatrix} K_x(\hat{x}) \\ K_\theta(\hat{x}) \end{bmatrix} \quad (4.108)$$

and where $K_f(\hat{x})$ is given by (2.37) with $P(\hat{x})$ being the positive definite solution to:

$$F(\hat{x})P + PF'(\hat{x}) - PH'_a(\hat{x})V^{-1}H_a(\hat{x})P + W_a = 0 \quad (4.109)$$

The SDARE filter is given by equations (4.106) – (4.109).

Observability Requirements A system can be observable in the nonlinear sense as defined by (2.9) and yet fail the “linear system” observability test defined for the pair $[F(\hat{x}), H(\hat{x})]$. When using the SDARE nonlinear filtering methodology, the system under study must pass both the linear and nonlinear observability tests. Then, not only is it truly observable in the nonlinear sense so that an observer can exist for the system, but

it will also be possible to use the “linear systems” algebraic Riccati equation as a mechanism for generating filter gains.

The Separate-Parameter SDARE Filter The technique defined above requires the solution of an $(n+p)^{\text{th}}$ order algebraic Riccati equation on each pass through the filter, where n and p are the number of states and unknown parameters, respectively. Because this algebraic Riccati equation must be solved in real time, in problems of higher dimension, time loading and/or the cost for controller electronics can become an issue. Another related issue is that of numerical ill-conditioning due to the larger size of the matrices involved. This problem is addressed by this author in [18] where a two-stage arrangement is developed for the nonlinear SDARE filter when applied to state and parameter estimation. The original $(n+p)^{\text{th}}$ order filter is broken into an n^{th} order “parameter-free” state estimator, and a p^{th} order “separate-parameter” filter, where p is the number of parameters and n the number of states. The $(n+p)^{\text{th}}$ order ARE is replaced by a p^{th} order ARE and an n^{th} order ARE which must be solved on-line on each pass through the filter, plus a $n \times p^{\text{th}}$ dimension matrix differential equation which must be integrated on-line. This method has been shown to perform successfully in several examples in [18] and has been successfully applied in [35] to an induction motor.

4.4.2 Examples

4.4.2.1 Friction Estimation and Compensation: A second-order system with friction is considered:

$$\begin{aligned}\dot{x}_1 &= x_2 \\ \dot{x}_2 &= -\theta \operatorname{sgn}(x_2) + u\end{aligned}$$

with θ being the coefficient of friction to be estimated. The position x_1 is measured:

$$y(x) = x_1$$

Although the measurement is noise free, the filter is given a nonzero measurement noise spectral density so that the filter gains are finite, and the process noise is selected to “excite” all of the states of the augmented system:

$$V = [1] \quad W_x = \begin{bmatrix} 0 & 0 \\ 0 & 1 \end{bmatrix} \quad W_\theta = [1]$$

The matrices of the state-augmented SDARE filter, (4.99)-(4.102) which will be used to estimate both the state vector and friction coefficient, are

$$A = \begin{bmatrix} 0 & 1 \\ 0 & 0 \end{bmatrix} \quad B(\hat{x}) = \begin{bmatrix} 0 \\ -\text{sgn}(\hat{x}_2) \end{bmatrix} \quad H = [1 \quad 0] \quad D = \begin{bmatrix} 0 \\ 1 \end{bmatrix}$$

All three states of the augmented system are observable, as the following algebraic observability test so indicates. Noting that $H_a = [1 \quad 0 \quad 0]$:

$$\text{rank} \begin{bmatrix} H'_a & F'(\hat{x})H'_a & (F'(\hat{x}))^2 H'_a \end{bmatrix} = \text{rank} \begin{bmatrix} 1 & 0 & 0 \\ 0 & 1 & 0 \\ 0 & 0 & -\text{sgn}(\hat{x}_2) \end{bmatrix} = 3$$

thus the system is observable for all \hat{x} .

The control law in this example is taken to be of the form

$$u = -200(\hat{x}_1 - x_d) - 20\hat{x}_2 + \hat{\theta} \text{sgn}(\hat{x}_2)$$

where x_d is the desired value of the position y . The last term in the control law results in friction compensation. The gains were selected to yield a natural frequency of 10 rad/sec and damping factor of 0.707. Figure 4.4 shows the transient response of the combined state and friction coefficient estimator with a square wave reference input shown (solid line) and initial conditions

$$x_1(0) = 0 \quad \hat{x}_1(0) = 0 \quad x_2(0) = 0 \quad \hat{x}_2(0) = 0 \quad \theta = 50 \quad \hat{\theta}(0) = 0$$

The estimated coefficient of friction converges on the actual value, and as it does, tracking response improves. The hangoff error present initially is eliminated after several cycles.

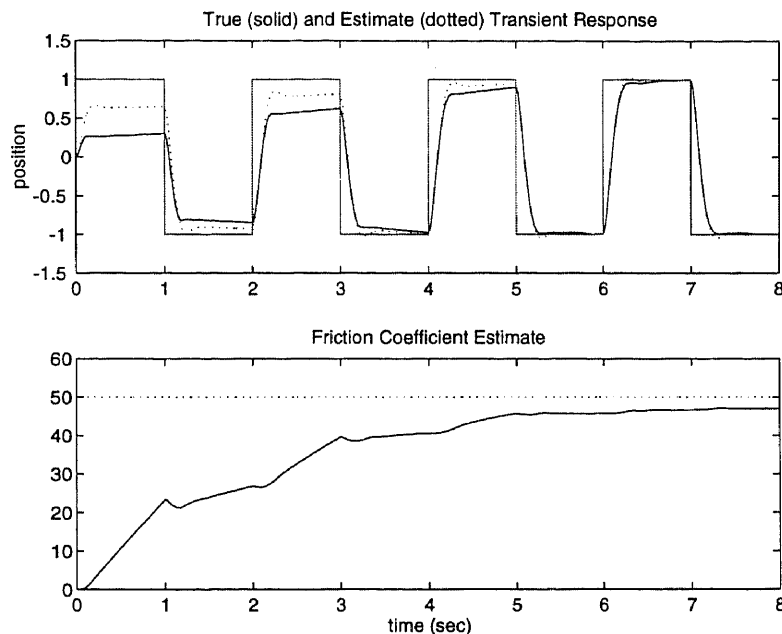

Figure 4.4 SDARE Filter Performance, Friction Estimation And Compensation Example

4.4.2.2 Damped Harmonic Oscillator: A linear second-order system with natural frequency θ_1 and damping θ_2 is given by

$$\begin{aligned}\dot{x}_1 &= x_2 \\ \dot{x}_2 &= -\theta_1 x_1 - \theta_2 x_2 + u\end{aligned}$$

It is assumed that the state x_1 is available for direct noise-free measurement, and that the two parameters are unknown but constant. The nonlinear observability test, equation (2.9), is applied to the augmented nonlinear system with $\underline{x} = [x_1 \quad x_2 \quad \theta_1 \quad \theta_2]'$. Thus, the observation equation and state equation function $f(\underline{x})$ are given by:

$$y = h(\underline{x}) = x_1 \quad f(\underline{x}) = \begin{bmatrix} x_2 \\ -\theta_1 x_1 - \theta_2 x_2 + u \\ 0 \\ 0 \end{bmatrix}$$

The observability test matrix (2.9) is:

$$\begin{bmatrix} 1 & 0 & 0 & 0 \\ 0 & 1 & 0 & 0 \\ -\theta_1 & -\theta_2 & -x_1 & -x_2 \\ \theta_1 \theta_2 & (-\theta_1 + \theta_2^2) & (-x_2 + \theta_2 x_1) & (\theta_1 x_1 + 2\theta_2 x_2 - u) \end{bmatrix}$$

has full rank as long as the state $\{x_1, x_2\}$ avoids the origin. In other words, the nonlinear system is observable if it is persistently excited. However, it is shown below that the system does not pass the linear observability test unless the parameter dynamics model provided to the filter is modified. There are two parameters and two parameter dynamic equations that enter into the filter. One is left alone and the other is changed to a markov process with a very long (10^5) time constant:

$$\begin{aligned} \dot{\theta}_1 &= \beta_1 \\ \dot{\theta}_2 &= -\tau \theta_2 + \beta_2 \end{aligned}$$

In this example the matrices of the state-augmented SDARE filter are

$$A = \begin{bmatrix} 0 & 1 \\ 0 & 0 \end{bmatrix} \quad B(\hat{x}) = \begin{bmatrix} 0 & 0 \\ -\hat{x}_1 & -\hat{x}_2 \end{bmatrix} \quad H = [1 \quad 0] \quad D = \begin{bmatrix} 0 \\ 1 \end{bmatrix}$$

so in this case

$$F(\hat{x}) = \begin{bmatrix} 0 & 1 & 0 & 0 \\ 0 & 0 & -\hat{x}_1 & -\hat{x}_2 \\ 0 & 0 & 0 & 0 \\ 0 & 0 & 0 & -\tau \end{bmatrix}$$

Noting that $H_a = [1 \quad 0 \quad 0 \quad 0]$, we find

$$\text{rank} \begin{bmatrix} H'_a & F(\hat{x})H'_a & F^2(\hat{x})H'_a & F^3(\hat{x})H'_a \end{bmatrix} = \text{rank} \begin{bmatrix} 1 & 0 & 0 & 0 \\ 0 & 1 & 0 & 0 \\ 0 & 0 & -\hat{x}_1 & 0 \\ 0 & 0 & -\hat{x}_2 & \tau\hat{x}_2 \end{bmatrix}.$$

Thus the system passes the linear observability test for all \hat{x} except the origin, if τ is not equal to zero.

The simulation results for this system, for the following numerical data,

$$V = [1] \quad W_x = \begin{bmatrix} 0 & 0 \\ 0 & 1 \end{bmatrix} \quad W_\theta = \begin{bmatrix} 1 & 0 \\ 0 & 1 \end{bmatrix} \quad \tau = -1e-5$$

the following initial conditions,

$$x_1(0) = 0 \quad \hat{x}_1(0) = 0 \quad x_2(0) = 0 \quad \hat{x}_2(0) = 0 \quad \theta_1 = 1 \quad \hat{\theta}_1(0) = 0 \quad \theta_2 = 0.1 \quad \hat{\theta}_2(0) = 0$$

and the control input

$$u = \sin(t) + \sin(5t)$$

are shown in Figure 4.5 and Figure 4.6. The estimation errors all converge to zero.

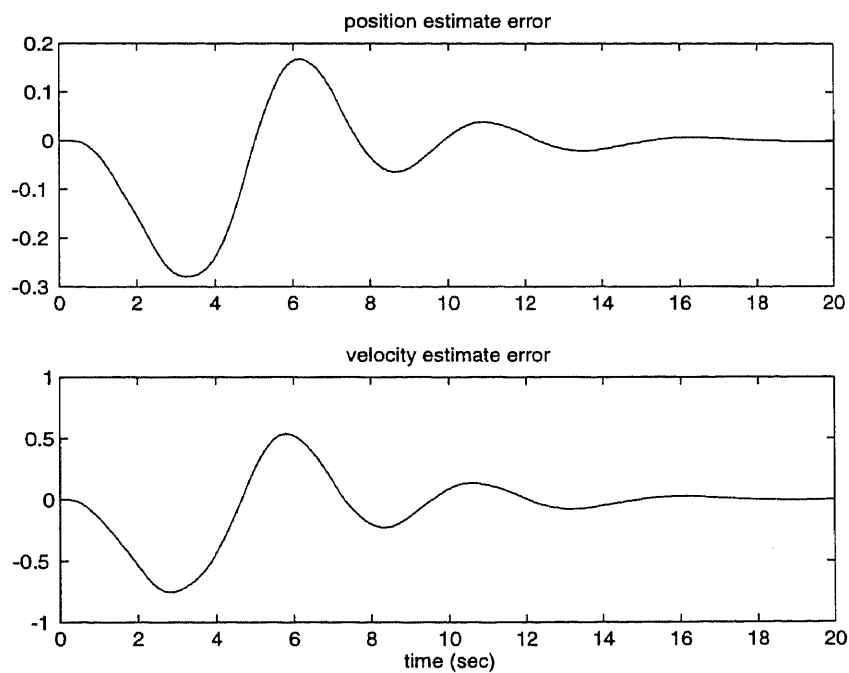

Figure 4.5 State Estimation Error, Damped Harmonic Oscillator

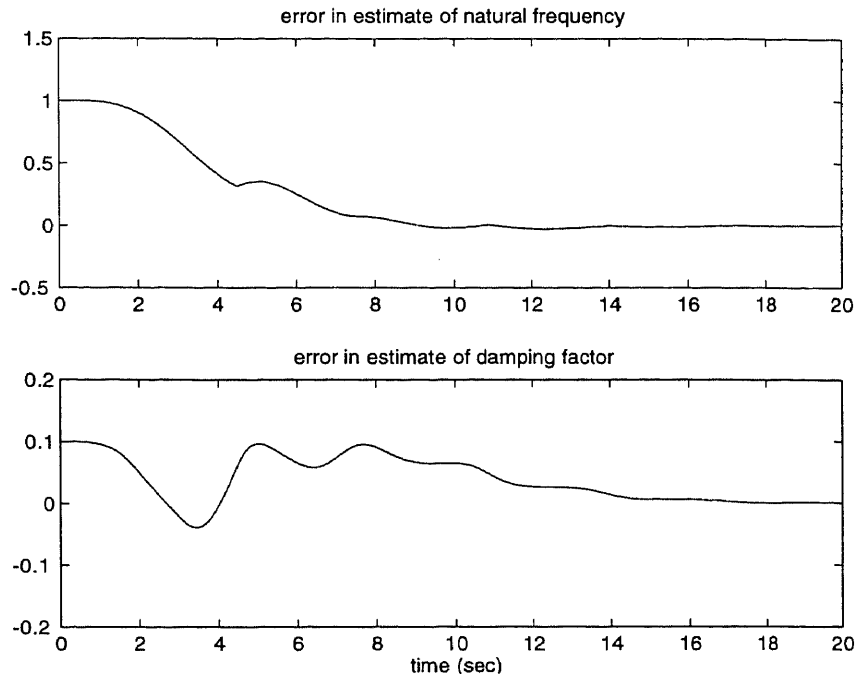

Figure 4.6 Parameter Estimation Error, Damped Harmonic Oscillator

4.4.3 Discussion

In this last example a system with two unknown parameters was found to be nonlinearly observable for all x in a region of the state space, but not linearly observable in that same region. As a result, the SDARE would not provide gains for use in the SDARE filter. The parameter states each contribute a pole at the origin and a row of zeros in $F(\hat{x})$ which results in the loss of linear observability needed to solve the ARE at each instant in time. To avoid this problem, each new parameter state must be disguised from the others by adding insignificant terms to those equations which make those parameter states “linearly” observable. The ARE will then provide a set of gains for what it sees as a linearly observable system. If the system is truly observable, the filter may converge. However, as the number of unknown parameters increases (beyond two), it become more difficult to fool the ARE solver by altering the parameter state dynamics, and thus the

suitability of the SDARE method decreases. The technique in the next section was developed to avoid this problem.

4.5 A New Nonlinear Filter

In this section a new nonlinear filter is proposed which avoids the shortcomings of the SDARE filter. This new filter does not require that the dynamic system be linearly observable at every instant, as does the SDARE filter. Instead, it must be observable over a finite time interval $[0, T]$. This essential difference is achieved through the use of a **differential** Riccati equation rather than the algebraic Riccati equation as used in the SDARE filter [32].

The new filter is generated using the State Dependent Coefficient (SDC) representation of the nonlinear plant. Both the state estimate and covariance propagation equations are based upon this SDC system representation. Thus, this filter is the natural nonlinear extension of the time-varying Kalman filter to nonlinear systems using the State Dependent Riccati Equation approach. Because it involves a state dependent differential Riccati equation, it is similar to the Extended Kalman filter (EKF); however, the EKF involves jacobian matrices, whereas the new filter involves the SDC matrices.

The stability of both the new filter and the Extended Kalman Filter (EKF) when applied to the joint state and parameter estimation problem are examined below. Ljung has shown in [25] that the EKF, when applied to this problem, does **not** possess the property of global asymptotic convergence, but in fact may diverge or provide biased estimates. Nevertheless, for the EKF, a candidate Lyapunov function is derived that

proves, under mild assumptions, the existence of a semi-global region of asymptotic stability.

4.5.1 Filtering Equations

In the definition of the new general nonlinear filtering approach, we consider the general, time-dependent nonlinear system

$$\begin{aligned}\dot{x} &= f(x) + w \\ y &= h(x) + v\end{aligned}\tag{4.110}$$

expressed in State Dependent Coefficient form as follows:

$$\begin{aligned}\dot{x} &= F(x)x + w \\ y &= H(x)x + v\end{aligned}\tag{4.111}$$

The new filter being proposed is:

$$\begin{aligned}\dot{\hat{x}} &= F(\hat{x})\hat{x} + K_f(\hat{x})[y(x) - H(\hat{x})\hat{x}] \\ K_f(\hat{x}) &= PH'(\hat{x})V^{-1}\end{aligned}\tag{4.112}$$

where P is the solution of the state dependent, matrix differential Riccati equation

$$\dot{P} = F(\hat{x})P + PF'(\hat{x}) - PH'(\hat{x})V^{-1}H(\hat{x})P + W\tag{4.113}$$

with initial condition

$$P(0) = P_0 = E[(\hat{x}(0) - x(0))(\hat{x}(0) - x(0))']$$

The matrices W and V are symmetric, possibly time-varying design matrices, positive semi-definite and positive definite, respectively, to be defined by the user. They are essentially the equivalent of the process and observation noise spectral density matrices of the linear Kalman filter.

Note 1 This filter given above differs from the Extended Kalman filter for the nonlinear system (4.110), in that there is no use of the jacobians of the system and observation

nonlinear function vectors, $f(t, x)$ and $h(t, x)$. Instead, the filter is entirely defined in terms of the matrices given by the State Dependent Coefficient form (4.111). The EKF, on the other hand, is given by:

$$\begin{aligned}\dot{\hat{x}} &= F(\hat{x})\hat{x} + K_f(\hat{x})[y(x) - H(\hat{x})\hat{x}] \\ K_f(\hat{x}) &= P\bar{H}'(\hat{x})V^{-1}\end{aligned}\tag{4.114}$$

and P given by the solution of the matrix differential Riccati equation

$$\dot{P} = \bar{F}(\hat{x})P + P\bar{F}'(\hat{x}) - P\bar{H}'(\hat{x})V^{-1}\bar{H}(\hat{x})P + W\tag{4.115}$$

where $\bar{F}(\hat{x})$ and $\bar{H}(\hat{x})$ are the jacobians of the vectors $f(\hat{x})$ and $h(\hat{x})$, respectively.

Unlike $F(\hat{x})$ and $H(\hat{x})$ of the new filter, the jacobians do not permit the flexibility of parameterization.

Note 2 Cloutier, et.al., in [8] and [9], did not have the option of using a differential Riccati equation in their definition of the nonlinear SDARE regulator, because in the underlying linear optimal control problem the Riccati equation must be solved backwards in time. They chose therefore to use the control algebraic Riccati equation as a means for generating regulator gains. In the case of the nonlinear filtering problem, however, the underlying optimal filtering problem involves a covariance propagation equation that moves forward in time, making the extension to a real-time, nonlinear algorithm possible. The generation of the temporal Riccati solution using a differential rather than an algebraic Riccati equation also makes sense from a computational viewpoint because it is much less computationally demanding to propagate a Riccati equation one step forward in time by numerical integration than it is to solve the algebraic Riccati equation.

4.5.2 Local Stability

Theorem 4-3 – Assume that the SDC matrices $F(x)$ and $H(x)$ are smooth, having continuous first derivatives, and that the pair $(F(x), H(x))$ is observable in a small neighborhood Ω around \hat{x} . Then the new nonlinear filter, (4.112)-(4.113), is locally asymptotically stable.

Proof Propagation of the error between the true and estimated states, $e = x - \hat{x}$, is governed by the dynamic equation:

$$\dot{e} = F(x)x + w - F(\hat{x})\hat{x} + K_f(\hat{x})[y(x) - H(\hat{x})\hat{x}]$$

Since $F(x)$ and $H(x)$ are smooth, it is possible to represent each by a partial Taylor series of $F(\hat{x})$ and $H(\hat{x})$ expanded about \hat{x} :

$$F(x) = F(\hat{x}) + \frac{\partial F(\hat{x})}{\partial \hat{x}}(x - \hat{x}) + O(e^2)$$

$$H(x) = H(\hat{x}) + \frac{\partial H(\hat{x})}{\partial \hat{x}}(x - \hat{x}) + O(e^2)$$

which is valid in some small neighborhood Ω around \hat{x} . Thus,

$$F(x)x \cong F(\hat{x})x + \frac{\partial F(\hat{x})}{\partial \hat{x}}ex$$

The second term in this equation is small compared to the first because of the presence of e , and can therefore be ignored, leaving $F(x)x \cong F(\hat{x})x$. Similarly, for $H(x)$ we have

$$H(x)x \cong H(\hat{x})x$$

Therefore, in a small neighborhood about \hat{x} ,

$$\dot{e} = F(\hat{x})x - F(\hat{x})\hat{x} + K_f(\hat{x})[H(\hat{x})x - H(\hat{x})\hat{x}] + w$$

which, neglecting noise is,

$$\dot{e} = [F(\hat{x}) - K_f(\hat{x})H(\hat{x})]e \tag{4.116}$$

Since Ω is small and both $F(x)$ and $H(x)$ are smooth, the matrix $[F(\hat{x}) - K_f(\hat{x})H(\hat{x})]$ is approximately constant for all \hat{x} in Ω . By Riccati equation theory, this matrix is guaranteed to be Hurwitz (i.e. all eigenvalues left of the imaginary axis), thus (4.116) is stable, locally and asymptotically. \square

4.5.3 Application to Bilinear Dynamic Systems

System Class C, which includes terms involving the multiplication of unknown parameters and unmeasured states, can be represented as follows:

$$\dot{x} = (A(t) + E(\theta))x + (B(t) + G(\theta))u + w_x \quad (4.117)$$

$$\dot{\theta} = w_\theta$$

$$y = (C(t) + D(\theta))x + v \quad (4.118)$$

The vectors w_x , w_θ and v are white noise processes. The known input $B(t)u$ in equation (4.117) above will be dropped from this point forward for brevity. If a known control input exists, it must simply be added where appropriate in the filtering equations that follow.

The state and parameter vectors are appended in the usual manner, yielding

$$\begin{bmatrix} \dot{x} \\ \dot{\theta} \end{bmatrix} = \begin{bmatrix} A + E(\theta) & 0 \\ 0 & 0 \end{bmatrix} \begin{bmatrix} x \\ \theta \end{bmatrix} + \begin{bmatrix} G(\theta) \\ 0 \end{bmatrix} u + \begin{bmatrix} w_x \\ w_\theta \end{bmatrix} \quad (4.119)$$

$$y = [(C + D(\theta)) \quad 0] \begin{bmatrix} x \\ \theta \end{bmatrix} + v \quad (4.120)$$

However, because the system is bilinear the following relationships may be defined:

$$E(\theta)x = R(x)\theta$$

$$G(\theta)u = Q(u)\theta$$

$$D(\theta)x = U(x)\theta$$

where $E(\theta) \in \mathfrak{R}^{n \times n}$, $R(x) \in \mathfrak{R}^{n \times p}$, $G(\theta) \in \mathfrak{R}^{n \times m}$, $Q(u) \in \mathfrak{R}^{n \times p}$, $D(\theta) \in \mathfrak{R}^{m \times n}$, and

$U(x) \in \mathfrak{R}^{m \times p}$. As a result, the system equations (4.119)-(4.120) can be expressed as

$$\begin{bmatrix} \dot{x} \\ \dot{\theta} \end{bmatrix} = \begin{bmatrix} A + E(\theta) & Q(u) \\ 0 & 0 \end{bmatrix} \begin{bmatrix} x \\ \theta \end{bmatrix} + \begin{bmatrix} w_x \\ w_\theta \end{bmatrix} \quad (4.121)$$

$$y = \begin{bmatrix} C + D(\theta) & 0 \end{bmatrix} \begin{bmatrix} x \\ \theta \end{bmatrix} + v \quad (4.122)$$

or in the following equivalent form:

$$\begin{bmatrix} \dot{x} \\ \dot{\theta} \end{bmatrix} = \begin{bmatrix} A & R(x) + Q(u) \\ 0 & 0 \end{bmatrix} \begin{bmatrix} x \\ \theta \end{bmatrix} + \begin{bmatrix} w_x \\ w_\theta \end{bmatrix} \quad (4.123)$$

$$y = \begin{bmatrix} C & U(x) \end{bmatrix} \begin{bmatrix} x \\ \theta \end{bmatrix} + v \quad (4.124)$$

In fact, any linear parameterization relating (4.121)-(4.122) and (4.123)-(4.124) is also a valid and exact representation of the underlying system dynamics. If we define the parameterization scalars α and β , $0 \leq \alpha \leq 1$, $0 \leq \beta \leq 1$, we then have

$$\begin{bmatrix} \dot{x} \\ \dot{\theta} \end{bmatrix} = \begin{bmatrix} A + \alpha E(\theta) & B + (1 - \alpha)R(x) + Q(u) \\ 0 & 0 \end{bmatrix} \begin{bmatrix} x \\ \theta \end{bmatrix} + \begin{bmatrix} w_x \\ w_\theta \end{bmatrix} \quad (4.125)$$

$$y = \begin{bmatrix} C + \beta D(\theta) & (1 - \beta)U(x) \end{bmatrix} \begin{bmatrix} x \\ \theta \end{bmatrix} + v \quad (4.126)$$

Thus, parameterized system matrices are defined:

$$F_\alpha(x, \theta, u) = \begin{bmatrix} A + \alpha E(\theta) & (1 - \alpha)R(x) + Q(u) \\ 0 & 0 \end{bmatrix}$$

$$H_\beta(x, \theta) = \begin{bmatrix} C + \beta D(\theta) & (1 - \beta)U(x) \end{bmatrix}$$

so that in terms of the appended state $\underline{x}' = [x' \quad \theta']$, the bilinear system can be represented as:

$$\dot{\underline{x}} = F_{\alpha}(\underline{x}, u)\underline{x} + w \quad (4.127)$$

$$y = H_{\beta}(\underline{x})z + v \quad (4.128)$$

The new filter, when applied to this system is therefore:

$$\begin{aligned} \dot{\hat{\underline{x}}} &= F_{\alpha}(\hat{\underline{x}}, u)\hat{\underline{x}} + K_f(\hat{\underline{x}})[y(\underline{x}) - H_{\beta}(\hat{\underline{x}})\hat{\underline{x}}] \\ K_f(\hat{\underline{x}}) &= PH'(\hat{\underline{x}})V^{-1} \end{aligned} \quad (4.129)$$

where P is the solution of the matrix Riccati differential equation

$$\begin{aligned} \dot{P}(t) &= F_{\alpha}(\hat{\underline{x}}, u)P + PF'_{\alpha}(\hat{\underline{x}}, u) - PH'_{\beta}(\hat{\underline{x}})V^{-1}H_{\beta}(\hat{\underline{x}})P + W \\ P(0) &= P_0 \end{aligned} \quad (4.130)$$

The EKF is also to be generated, as a point of comparison, for bilinear systems. The EKF for the augmented system (4.127) - (4.128) is:

$$\begin{aligned} \dot{\hat{\underline{x}}} &= F_{\alpha}(\hat{\underline{x}}, u)\hat{\underline{x}} + K_f(\hat{\underline{x}})[y(\underline{x}) - H_{\beta}(\hat{\underline{x}})\hat{\underline{x}}] \\ K_f(\hat{\underline{x}}) &= P\overline{H}'(\hat{\underline{x}})V^{-1} \end{aligned} \quad (4.131)$$

where P is the solution of the matrix Riccati differential equation.

$$\begin{aligned} \dot{P}(t) &= \overline{F}(\hat{\underline{x}}, u)P + P\overline{F}'(\hat{\underline{x}}, u) - P\overline{H}'(\hat{\underline{x}})V^{-1}\overline{H}(\hat{\underline{x}})P + W \\ P(0) &= P_0 \end{aligned} \quad (4.132)$$

It involves the jacobian matrices:

$$\overline{F}(x, \theta, u) = \begin{bmatrix} A + E(\theta) & B + R(x) + Q(u) \\ 0 & 0 \end{bmatrix} \quad (4.133)$$

$$\overline{H}(x, u) = [C + D(\theta) \quad U(x)] \quad (4.134)$$

Notice that these are invariant with respect to parameterization value.

4.5.4 Stability Background

Before embarking immediately upon an assessment of stability for the filters defined above, it will be helpful to step back within the body of known theory, to examine related

problems that we know possesses guaranteed stability properties, and review the applicable stability theory. Then it will be more readily apparent how stability is affected by the extension being considered. To move back into known theory, it will be assumed that there exists perfect knowledge of the system parameter vector θ in for the bilinear system, (4.117) - (4.118). That is, the parameter vector θ is known initially and the process noise driving the parameter dynamics w_θ is zero for all $t > 0$. The filtering problem then becomes one of state estimation only, and the new filter (4.129)-(4.130), and the EKF (4.131)- (4.132), becomes a standard, linear Kalman filter, for which stability is guaranteed. The theory reviewed will cover:

- a linear, time-invariant system and filter with gain given by filter algebraic Riccati equation,
- a linear, time-invariant system and time-varying Kalman filter, and
- a linear, time-varying system and time-varying Kalman filter.

Lyapunov stability can be shown in all of these cases. The impact that the extended condition -- parameter uncertainty -- has upon stability, is examined for both the EKF and the new filter.

Case A: Time-Invariant System and Filter The system and filter are in this case given by:

$$\begin{aligned} \dot{\hat{x}}(t) &= A\hat{x}(t) + K(y(t) - C\hat{x}(t)) \\ \dot{x}(t) &= Ax(t) + w(t) & 0 &= AP + PA' - PC'V^{-1}CP + W \\ y(t) &= Cx(t) + v(t) & K &= PC'V^{-1} \end{aligned}$$

To guarantee the existence of a stabilizing gain matrix K , the fixed design matrices V and W must be positive definite and positive semi-definite, respectively. In addition, the

pairs $[A, C]$ and $[A, W^{1/2}]$ must be observable and controllable, respectively. This guarantees the existence of a positive definite solution to the filter algebraic Riccati equation, and the existence of K .

To prove stability, we consider the candidate Lyapunov function:

$$L(e) = e'(t)P^{-1}e(t)$$

involving the inverse of the **constant** matrix P , and the error vector, $e(t) = x(t) - \hat{x}(t)$.

The error dynamics are easily shown to be $\dot{e}(t) = (A - KC)e(t) + w(t) + Kv(t)$. Thus the candidate function has the following time derivative along the solution trajectories,

$$\begin{aligned}\dot{L} &= \dot{e}'P^{-1}e + e'P^{-1}\dot{e} \\ &= e'[(A - KC)'P^{-1} + P^{-1}(A - KC)]e + 2e'P^{-1}\eta\end{aligned}$$

where $\eta = w + K(t)v$ is the noise. Noise is neglected below as it does not impact the stability result. Noting that the algebraic Riccati equation can be manipulated as follows:

$$\begin{aligned}0 &= AP + PA' - KCP - PC'K' + PC'K' + W \\ &= (A - KC)P + P(A - KC)' + KVK' + W \\ &= P^{-1}(A - KC) + (A - KC)'P^{-1} + P^{-1}(KVK' + W)P^{-1}\end{aligned}$$

one finds that when substituted into the above,

$$\dot{L} = -e'P^{-1}[KVK' + W]P^{-1}e$$

Although W and KVK' are individually only positive semi-definite, given standard Riccati equation theory, their sum is guaranteed to be positive definite.

Consider now the conditions of Theorem 2-2. Since the matrix P is symmetric and positive definite, the same is true for P^{-1} , so that

$$(a) \quad L(e) > 0 \quad \text{for all } e \neq 0$$

satisfying Condition (a). In addition, the matrix $[KVK' + W]$ is symmetric and positive definite, and therefore $P^{-1}[KVK' + W]P^{-1}$ is symmetric and positive definite also, such that

$$(b) \quad \dot{L}(e) < 0 \quad \text{for all } e \neq 0$$

which satisfies Condition (b). Thus both conditions of Theorem 2-2 are satisfied. $L(e)$ is therefore a Lyapunov function and the global asymptotic stability of the filter is proved.

Case B: Time-Invariant System and Time-Varying Kalman Filter The system equations are the same as above, however the filter is now given by

$$\begin{aligned}\hat{\dot{x}}(t) &= A\hat{x}(t) + K(t)(y(t) - C\hat{x}(t)) \\ \dot{P}(t) &= AP(t) + P(t)A' - P(t)C'V^{-1}CP(t) + W \\ K(t) &= P(t)C'V^{-1}\end{aligned}$$

So, for this case the error dynamics,

$$\dot{e}(t) = (A - K(t)C)e(t) + w(t) + K(t)v(t)$$

are time varying.

To prove stability, we consider a candidate Lyapunov function involving the inverse of the **time-varying** covariance matrix $P(t)$:

$$L(e) = e'(t)P^{-1}(t)e(t)$$

Taking the time derivative along the solution trajectories yields,

$$\dot{L} = \dot{e}'P^{-1}(t)e + e'P^{-1}(t)\dot{e} - e'P^{-1}(t)\dot{P}(t)P^{-1}(t)e$$

into which we will substitute the expressions for \dot{e} and $\dot{P}(t)$. Before doing so, however, note that the Riccati equation can be expressed as follows:

$$\dot{P}(t) = (A - K(t)C)P(t) + P(t)(A - K(t)C)' + P(t)C'V^{-1}CP(t) + W$$

Thus, upon substitution into the above,

$$\dot{L}(e) = e' \left\{ \begin{array}{l} (A - K(t)C)'P^{-1}(t) + P^{-1}(t)(A - K(t)C) \\ - P^{-1}(t)((A - K(t)C)P(t) + P(t)(A - K(t)C) + P(t)C'V^{-1}CP + W)P^{-1} \end{array} \right\} e$$

where we have again neglected the noise term. After simplifying this expression becomes:

$$\begin{aligned} \dot{L}(e) &= -e' \{ C'V^{-1}C + P^{-1}(t)WP^{-1}(t) \} e \\ &= -e' P^{-1}(t) \{ K(t)VK'(t) + W \} P^{-1}(t) e \end{aligned}$$

which is of the same form as the previous case, except that $K(t)$ and $P(t)$ are now time varying.

Although the system is time invariant, the filter is not, so to assess stability it is necessary to apply the more restrictive conditions of Theorem 2-1. This theorem requires that the candidate, time-varying Lyapunov function be bounded from above and below by fixed, time invariant positive definite functions. In addition, the time derivative of the candidate function must be bounded from above by a fixed, time invariant negative definite function.

To identify an upper bound on $L(t)$ it is necessary that no row or column of $P(t)$ go to zero as $t \rightarrow \infty$. This is true only if the system is controllable by the noise, i.e. that the time invariant pair $[A, W^{1/2}]$ is controllable. In general this requires that W be positive semi-definite, including diagonal elements that guarantee $\text{rank } P(t) = n$, or equivalently, that there exist no zero rows of $P(t)$ for all $t > 0$. Then it is possible to identify a scalar value on the unit hypersphere

$$\varepsilon = \sup_{\|e\|=1} e' P^{-1}(t) e \quad \text{for all } t > 0$$

such that

$$L(t) = e'P^{-1}(t)e \leq \varepsilon e'e \quad \text{for all } t > 0$$

Thus it is necessary that the system be controllable by the process noise matrix W for the Lyapunov function to exist.

To identify a lower bound, it is necessary that the time invariant system be observable as defined by the pair $[A, C]$. If not observable, the covariance of the unobservable state(s) which are being driven (i.e. controlled) by the process noise as defined above will tend to infinity as time increases. The associated diagonal elements of the covariance inverse $P^{-1}(t)$ will go to zero as a result, causing $L(t)$ to violate any lower quadratic bound that might be placed upon it. Thus, if the system is observable, $P^{-1}(t)$ will not go to zero and it will be possible to identify a minimum that occurs on the unit hypersphere .

$$\delta = \inf_{\|e\|=1} e'P^{-1}(t)e \quad \text{for all } t > 0$$

Because $P^{-1}(t)$ is positive definite, δ is guaranteed to be greater than zero, so that

$$L(t) = e'P^{-1}(t)e \geq \delta e'e > 0$$

Thus it is necessary that the system be observable for the Lyapunov function to exist.

In summary we have

$$0 < \varepsilon e'e \leq L(t) \leq \delta e'e < \infty$$

and Theorem 2-1, Condition (a) is satisfied.

Consider next the time derivative of $L(t)$, which is, neglecting the noise term,

$$\dot{L}(e) = -e'P^{-1}(t)\{K(t)VK'(t) + W\}P^{-1}(t)e \quad (4.135)$$

Again, by standard Kalman filtering theory for a system that is both observable and controllable, the time-varying matrix that appears here is positive definite. Consequently,

it is possible to determine, for any particular initial covariance matrix which defines $P(t)$ for all t , a scalar value γ such that

$$\gamma = \inf_{\|e\|=1} e' P^{-1}(t) \{K(t)VK'(t) + W\} P^{-1}(t) e$$

Then,

$$\dot{L}(t) \leq -\gamma e'e < 0 \quad \text{for all } t > 0$$

which satisfies Condition (b) of Theorem 2-1. $L(t)$ is therefore a Lyapunov function, and the Kalman filter is asymptotically stable about the origin $e = 0$. Since the system is linear, asymptotic stability is assured globally.

Case C: Time-varying System and Time-varying Kalman Filter The analysis of stability in this case is identical to that of Case B and therefore will not be repeated. However, for time-varying systems, the controllability and observability requirements that must hold for a Lyapunov function to exist are defined in terms of the Observability and Controllability Grammians (see [16]) rather than the algebraic tests. If these requirements are satisfied, quadratic bound on the functions $L(t)$ and $\dot{L}(t)$ can be shown to exist, making $L(t)$ a Lyapunov function, and guaranteeing the asymptotic stability of the time-varying Kalman filter globally.

4.5.5 Stability with Bilinear Dynamic Systems

The error dynamics of the new filter and of the EKF both evolve in accordance with:

$$\begin{aligned} \dot{e} &= \underline{\dot{x}} - \underline{\dot{\hat{x}}} \\ &= F_\alpha(\underline{x}, u)x - F_\alpha(\underline{\hat{x}}, u)\underline{\hat{x}} - K_f(\underline{\hat{x}})[y - H_\beta(\underline{\hat{x}})\underline{\hat{x}}] \end{aligned} \quad (4.136)$$

where the gain matrix $K_f(\underline{\hat{x}})$ will depend which filter is used. It should be evident that we are free to choose the parameterization values, α and β , for both the true system and

the dynamic model used in the filter and that different values could be used for each.

There could be four different values used, that is. However, to avoid the added complication, we consider just two cases:

$$(1) \alpha = \beta = 0$$

$$(2) \alpha = \beta = 1$$

The same values are used in both the filter and in our representation of the true system.

Case (1) is examined first. Here,

$$F_0(x, u)x - F_0(\hat{x}, u)\hat{x} = \begin{bmatrix} A & (R(x) + Q(u)) \\ 0 & 0 \end{bmatrix} \begin{bmatrix} x \\ \theta \end{bmatrix} - \begin{bmatrix} A & (R(\hat{x}) + Q(u)) \\ 0 & 0 \end{bmatrix} \begin{bmatrix} \hat{x} \\ \hat{\theta} \end{bmatrix}$$

and

$$y(x) - H_0(\hat{x})\hat{x} = \begin{bmatrix} C & U(x) \end{bmatrix} \begin{bmatrix} x \\ \theta \end{bmatrix} - \begin{bmatrix} C & U(\hat{x}) \end{bmatrix} \begin{bmatrix} \hat{x} \\ \hat{\theta} \end{bmatrix}$$

These expressions involve the estimated and true state and parameter vectors. It would be useful to rewrite these in terms of submatrices that multiply the error vectors,

$e_x = x - \hat{x}$ and $e_\theta = \theta - \hat{\theta}$. To that end, the following substitutions are used:

$$Ax - A\hat{x} = Ae_x$$

$$\begin{aligned} R(x)\theta - R(\hat{x})\hat{\theta} &= R(e_x + \hat{x})\theta - R(\hat{x})(\theta - e_\theta) \\ &= R(e_x)\theta + R(\hat{x})\theta - R(\hat{x})\theta + R(\hat{x})e_\theta \\ &= R(e_x)\theta + R(\hat{x})e_\theta \\ &= E(\theta)e_x + R(\hat{x})e_\theta \end{aligned}$$

$$Q(u)\theta - Q(u)\hat{\theta} = Q(u)e_\theta$$

$$Cx - C\hat{x} = Ce_x$$

$$U(x)\theta - U(\hat{x})\hat{\theta} = D(\theta)e_x + U(\hat{x})e_\theta$$

Thus, the error dynamic and measurement equations can also be expressed as:

$$\begin{bmatrix} \dot{e}_x \\ \dot{e}_\theta \end{bmatrix} = \begin{bmatrix} A + E(\theta) & (R(\hat{x}) + Q(u)) \\ 0 & 0 \end{bmatrix} \begin{bmatrix} e_x \\ e_\theta \end{bmatrix} - \begin{bmatrix} K_{fx} \\ K_{f\theta} \end{bmatrix} [C + D(\theta) \quad U(\hat{x})] \begin{bmatrix} e_x \\ e_\theta \end{bmatrix} \quad (4.137)$$

$$y - H_0(\hat{x})\hat{x} = [C + D(\theta) \quad U(\hat{x})] \begin{bmatrix} e_x \\ e_\theta \end{bmatrix} \quad (4.138)$$

Note that the matrices in these expressions are different than those of the system equations, (4.121)-(4.122), or (4.123)-(4.124). There are two additional submatrices appearing in each, $R(\hat{x})$ and $U(\hat{x})$. In fact, you will note that with these terms, the matrices above are the jacobians of the system and observation vectors respectively, evaluated at the estimated state \hat{x} , the control vector u and the **true** parameter θ .

We now consider Case 2 where $\alpha = \beta = 1$. In this case

$$F_1(z, u)z - F_1(\hat{z}, u)\hat{z} = \begin{bmatrix} A + E(\theta) & Q(u) \\ 0 & 0 \end{bmatrix} \begin{bmatrix} x \\ \theta \end{bmatrix} - \begin{bmatrix} A + E(\hat{\theta}) & Q(u) \\ 0 & 0 \end{bmatrix} \begin{bmatrix} \hat{x} \\ \hat{\theta} \end{bmatrix}$$

and

$$y(z) - H_1(\hat{z})\hat{z} = [C + D(\theta) \quad 0] \begin{bmatrix} x \\ \theta \end{bmatrix} - [C + D(\hat{\theta}) \quad 0] \begin{bmatrix} \hat{x} \\ \hat{\theta} \end{bmatrix}$$

By going through the same type of algebraic manipulations as above, we find that in this case the error dynamics and measurement equation are:

$$\begin{bmatrix} \dot{e}_x \\ \dot{e}_\theta \end{bmatrix} = \begin{bmatrix} A + E(\hat{\theta}) & (R(x) + Q(u)) \\ 0 & 0 \end{bmatrix} \begin{bmatrix} e_x \\ e_\theta \end{bmatrix} - \begin{bmatrix} K_{fx} \\ K_{f\theta} \end{bmatrix} [C + D(\hat{\theta}) \quad U(x)] \begin{bmatrix} e_x \\ e_\theta \end{bmatrix} \quad (4.139)$$

$$y - H_1(\hat{z})\hat{z} = [C + D(\hat{\theta}) \quad U(x)] \begin{bmatrix} e_x \\ e_\theta \end{bmatrix} \quad (4.140)$$

These are identical in form to that of Case 1, (4.137)-(4.138); however, these involve x and $\hat{\theta}$, while those of Case 1 involved \hat{x} and θ .

In the more compact form, the error dynamics can be expressed exactly as either:

$$\text{Case 1:} \quad \dot{e} = \bar{F}(\hat{x}, \theta, u)e - K_f(\hat{x}, \hat{\theta}, u)\bar{H}(\hat{x}, \theta)e \quad (4.141)$$

$$\text{Case 2:} \quad \dot{e} = \bar{F}(x, \hat{\theta}, u)e - K_f(\hat{x}, \hat{\theta}, u)\bar{H}(x, \hat{\theta})e \quad (4.142)$$

So the error dynamics in either case depend on an estimated term and on a true term. It turns out that this complicates the proof of stability. Since neither case avoids this complication, we will continue only with Case 1 from this point forward.

4.5.5.1 Stability of the EKF: The following candidate Lyapunov function is proposed:

$$L(t) = e'P^{-1}(t)e \quad (4.143)$$

where $P(t)$ is the solution of a differential Riccati equation, either (4.129) or (4.132).

Taking the time derivative along the error state trajectory (4.141) yields

$$\begin{aligned} \dot{L}(t) &= \dot{e}'P^{-1}e + e'P^{-1}\dot{e} - e'P^{-1}\dot{P}P^{-1}e \\ &= e'\left[\bar{F}'(\hat{x}, \theta, u) - \bar{H}'(\hat{x}, \theta)K_f'(\hat{x}, \hat{\theta}, u)\right]P^{-1}e \\ &\quad + e'P^{-1}\left[\bar{F}(\hat{x}, \theta, u) - K_f(\hat{x}, \hat{\theta}, u)\bar{H}(\hat{x}, \theta)\right]e \\ &\quad - e'P^{-1}\left[\bar{F}(\hat{x}, \hat{\theta}, u)P + P\bar{F}'(\hat{x}, \hat{\theta}, u) - P\bar{H}'(\hat{x}, \hat{\theta})V^{-1}\bar{H}(\hat{x}, \hat{\theta})P + W\right]P^{-1}e \end{aligned}$$

where you will note that the covariance propagation equation of the EKF has been used to define \dot{P} . This is simplified in the same manner as done in previous section on Background, by subtracting and adding the term $\bar{H}'V^{-1}\bar{H}$ in the third line of the equation. Doing so results in

$$\begin{aligned} \dot{L}(t) &= e'\left[\bar{F}'(\hat{x}, \theta, u) - \bar{H}'(\hat{x}, \theta)K_f'(\hat{x}, \hat{\theta}, u)\right]P^{-1}e \\ &\quad + e'P^{-1}\left[\bar{F}(\hat{x}, \theta, u) - K_f(\hat{x}, \hat{\theta}, u)\bar{H}(\hat{x}, \theta)\right]e \\ &\quad - e'P^{-1}\left[\begin{array}{l} \bar{F}(\hat{x}, \hat{\theta}, u)P - P\bar{H}'(\hat{x}, \hat{\theta})V^{-1}\bar{H}(\hat{x}, \hat{\theta})P \\ + P\bar{F}'(\hat{x}, \hat{\theta}, u) - P\bar{H}'(\hat{x}, \hat{\theta})V^{-1}\bar{H}(\hat{x}, \hat{\theta})P \\ + P\bar{H}'(\hat{x}, \hat{\theta})V^{-1}\bar{H}(\hat{x}, \hat{\theta})P + W \end{array}\right]P^{-1}e \end{aligned}$$

noting that $\bar{H}V^{-1}\bar{H} = P^{-1}K_f\bar{H}$. After some rearrangement, this expression becomes

$$\begin{aligned}
 \dot{L}(t) = & e' \left[\bar{F}'(\hat{x}, \theta, u) - \bar{H}'(\hat{x}, \theta) K_f'(\hat{x}, \hat{\theta}, u) \right] P^{-1} e \\
 & - e' \left[\bar{F}'(\hat{x}, \hat{\theta}, u) - \bar{H}'(\hat{x}, \hat{\theta}) K_f'(\hat{x}, \hat{\theta}, u) \right] P^{-1} e \\
 & + e' P^{-1} \left[\bar{F}(\hat{x}, \theta, u) - K_f(\hat{x}, \hat{\theta}, u) \bar{H}(\hat{x}, \theta) \right] e \\
 & - e' P^{-1} \left[\bar{F}(\hat{x}, \hat{\theta}, u) - K_f(\hat{x}, \hat{\theta}, u) \bar{H}(\hat{x}, \hat{\theta}) \right] e \\
 & - e' \left[\bar{H}'(\hat{x}, \hat{\theta}) V^{-1} \bar{H}(\hat{x}, \hat{\theta}) + P^{-1} W P^{-1} \right] e
 \end{aligned} \tag{4.144}$$

A quick look at the first four lines of this expression and one might think that they all cancel, but they do not. The true parameter vector θ appears in some, and the estimated parameter vector $\hat{\theta}$ in others. (In Case 2 it the true state x and the estimated state \hat{x} that preclude cancellation.) Further simplification of (4.144) can be accomplish by examining individual terms. For example,

$$\begin{aligned}
 \bar{F}(\hat{x}, \theta, u) - \bar{F}(\hat{x}, \hat{\theta}, u) &= \begin{bmatrix} A + E(\theta) & R(\hat{x}) + Q(u) \\ 0 & 0 \end{bmatrix} - \begin{bmatrix} A + E(\hat{\theta}) & R(\hat{x}) + Q(u) \\ 0 & 0 \end{bmatrix} \\
 &= \begin{bmatrix} E(\theta) - E(\hat{\theta}) & 0 \\ 0 & 0 \end{bmatrix} \\
 &= \begin{bmatrix} E(e_\theta) & 0 \\ 0 & 0 \end{bmatrix}
 \end{aligned}$$

Similarly,

$$\begin{aligned}
 \bar{H}(\hat{x}, \theta) - \bar{H}(\hat{x}, \hat{\theta}) &= [C + D(\theta) \quad U(\hat{x})] - [C + D(\hat{\theta}) \quad U(\hat{x})] \\
 &= [D(\theta) - D(\hat{\theta}) \quad 0] \\
 &= [D(e_\theta) \quad 0]
 \end{aligned}$$

So if a new matrix is defined:

$$S(e_\theta, \hat{x}, \hat{\theta}, u) = \left\{ \begin{bmatrix} E(e_\theta) & 0 \\ 0 & 0 \end{bmatrix} - K_f(\hat{x}, \hat{\theta}, u) \begin{bmatrix} D(e_\theta) & 0 \end{bmatrix} \right\} \quad (4.145)$$

then (4.144) can be expressed as:

$$\dot{L} = -e' \left\{ S(e_\theta, \hat{x}, \hat{\theta}, u)' P^{-1} - P^{-1} S(e_\theta, \hat{x}, \hat{\theta}, u) + \bar{H}'(\hat{x}, \hat{\theta}) V^{-1} \bar{H}(\hat{x}, \hat{\theta}) + P^{-1} W P^{-1} \right\} e$$

or equivalently,

$$\dot{L} = -e' P^{-1}(t) \{ (K(t) V K'(t) + W) - P(t) S' - S P(t) \} P^{-1}(t) e \quad (4.146)$$

This is a quadratic expression that contains two terms. The first term

$$(K'(t) V K(t) + W)$$

is that which appears with the standard Kalman filter for linear systems and state estimation only. This term is symmetric and will be positive definite if the system is controllable by the noise (as defined by W) and observable. The second term is symmetric but indefinite. Note that when parameter uncertainty is zero, i.e. $\hat{\theta} = \theta$, then $S = 0$, the second term disappears and the expression (4.146) reduces to exactly the same equation (4.135) as that of the standard Kalman filter for state estimation only. Thus the additional term represent the impact that parameter uncertainty has on this stability assessment. However, because $S \rightarrow 0$ as $e_\theta \rightarrow 0$, the first term can and will dominate the second in some region of the error state space including the origin. Clearly, this is true over some finite region around the origin where $e_\theta = 0$ where S vanishes, i.e. $S = 0$. In fact, the matrix function S of (4.145) is linear in e_θ and can be represented

$$S(e_\theta, \hat{x}, \hat{\theta}, u) = X(\hat{x}, \hat{\theta}, u) e_\theta$$

where X is an $(n+p) \times p$ matrix. Thus, we have

$$\dot{L} = -e' \left\{ P^{-1} (K(t) V K'(t) + W) P^{-1} - e_\theta' X P^{-1} - P^{-1} X e_\theta \right\} e \quad (4.147)$$

The new terms are cubic in the error, whereas the original terms are second order in the error. The second order, quadratic terms will dominate the cubic terms over a finite region of the error space, thus we can conclude that this function indicates that there exists a finite (as opposed to arbitrarily small) region of the error space wherein the candidate Lyapunov function is positive definite.

Theorem 4-4 – If the bilinear system described by equations (4.119) - (4.120) is:

(a) Controllable: The Controllability Grammian

$$N(T, t) = \int_t^T \Phi(T, \lambda) W W' \Phi'(T, \lambda) d\lambda$$

is non-singular for some finite interval $[t, T]$, where $\Phi(T, t)$ is defined by:

$$\dot{\Phi}(t, t_0) = F_\alpha(x(t), \theta(t), u(t)) \Phi(t, t_0) \quad \text{and} \quad \Phi(t_0, t_0) = I$$

given some positive semi-definite matrix W .

(b) Observable: The control input u persistently exciting over the interval $[t, T]$ as indicated by the non-singularity of the observability grammian:

$$M(t, t_0) = \int_t^T \Phi'(\lambda, t_0) H'_\beta(x(\lambda), \theta(\lambda)) H_\beta(x(\lambda), \theta(\lambda)) \Phi(\lambda, t_0) d\lambda$$

(c) Controllable and Observable along estimated trajectories: The bilinear system that satisfies Conditions (a) and (b) along the actual state trajectories $x(t)$ and with the true parameters θ , also satisfies (a) and (b) along the estimated state trajectories $\hat{x}(t)$ and with the estimated parameters $\hat{\theta}$. Then the EKF

$$\begin{aligned} \dot{\hat{x}} &= F_\alpha(\hat{x}) \hat{x} + K_f(\hat{x}) [y(x) - H_\beta(\hat{x}) \hat{x}] \\ K_f(\hat{x}) &= P \bar{H}'(\hat{x}) V^{-1} \end{aligned} \quad (4.148)$$

$$\dot{P}(t) = \bar{F}(\hat{x}, u) P + P \bar{F}'(\hat{x}, u) - P \bar{H}'(\hat{x}) V^{-1} \bar{H}(\hat{x}) P + W \quad P(0) = P_0 \quad (4.149)$$

is asymptotically stable in a semi-global region bounded in e_θ , where $\hat{x}' = [\hat{x}' \quad \hat{\theta}']$.

Proof By Condition (c), the covariance solution $P(t)$ over the interval is bounded above and below (as in the linear Kalman filter case), such that there exist scalar constants ε and δ :

$$\varepsilon = \sup_{\|e\|=1} e'P^{-1}(t)e \quad \text{for all } t > 0$$

$$\delta = \inf_{\|e\|=1} e'P^{-1}(t)e \quad \text{for all } t > 0$$

which bound the function (4.143):

$$0 < \varepsilon e'e \leq L(t) \leq \delta e'e < \infty$$

satisfying Condition (a) of Theorem 2-1. In addition, the term $KVK' + W$ in equation (4.146) is positive definite per Riccati equation theory, and bounded from below, such that there exists a positive scalar γ :

$$\gamma = \inf_{\|e\|=1} e'P^{-1}(t)\{K(t)VK'(t) + W\}P^{-1}(t)e$$

Thus there will exist a finite region

$$\|e_\theta\| \leq \kappa$$

where the positive definite term dominates the cubic terms in (4.147), such that the positive scalar

$$\rho = \inf_{\|e\|=1} e' \left\{ P^{-1}(K(t)VK'(t) + W)P^{-1} - e_\theta' X' P^{-1} - P^{-1} X e_\theta \right\} e \quad \text{over all } t > 0$$

exists. Then

$$\dot{L}(t) \leq -\rho e'e < 0 \quad \text{for all } t > 0$$

and Condition (b) of Theorem 2-1 is satisfied. Consequently, $L(t)$ is a Lyapunov function in the region $\|e_\theta\| \leq \kappa$ and the EKF is therefore asymptotically stable in that region. \square

The proof given above is valid if the assumed conditions are true. A difficulty arises in that we are unable to verify the validity of Condition (c). Although it is possible to assess the controllability and observability of the linear, augmented system given fixed, true parameters in the system A , B , and C matrices, we can only assume that this implies the observability and controllability of the augmented system along the estimated state and parameter trajectories. A test to verify that Condition (c) holds given (a) and (b) does not, as of yet, exist and is a potential topic for future research.

4.5.5.2 Stability of the New Filter: For the same candidate Lyapunov function

(4.143), with the “covariance” update equation of the new filter, one finds

$$\begin{aligned}\dot{L}(t) &= \dot{e}'P^{-1}e + e'P^{-1}\dot{e} - e'P^{-1}\dot{P}P^{-1}e \\ &= e'[\bar{F}'(\hat{x}, \theta, u) - \bar{H}'(\hat{x}, \theta)K_f'(\hat{x}, \hat{\theta}, u)]P^{-1}e \\ &\quad + e'P^{-1}[\bar{F}(\hat{x}, \theta, u) - K_f(\hat{x}, \hat{\theta}, u)\bar{H}(\hat{x}, \theta)]e \\ &\quad - e'P^{-1}[F_\alpha(\hat{x}, \hat{\theta}, u)P + PF_\alpha(\hat{x}, \hat{\theta}, u) - PH_\beta(\hat{x}, \hat{\theta})V^{-1}H_\beta(\hat{x}, \hat{\theta})P + W]P^{-1}e\end{aligned}$$

This is simplified in the same manner as done previously:

$$\begin{aligned}\dot{L}(t) &= e'[\bar{F}'(\hat{x}, \theta, u) - \bar{H}'(\hat{x}, \theta)K_f'(\hat{x}, \hat{\theta}, u)]P^{-1}e \\ &\quad - e'[F_\alpha'(\hat{x}, \hat{\theta}, u) - H_\beta'(\hat{x}, \hat{\theta})K_f'(\hat{x}, \hat{\theta}, u)]P^{-1}e \\ &\quad + e'P^{-1}[\bar{F}(\hat{x}, \theta, u) - K_f(\hat{x}, \hat{\theta}, u)\bar{H}(\hat{x}, \theta)]e \\ &\quad - e'P^{-1}[F_\alpha(\hat{x}, \hat{\theta}, u) - K_f(\hat{x}, \hat{\theta}, u)H_\beta(\hat{x}, \hat{\theta})]e \\ &\quad - e'[H_\beta'(\hat{x}, \hat{\theta})V^{-1}H_\beta(\hat{x}, \hat{\theta}) + P^{-1}WP^{-1}]e\end{aligned}\tag{4.150}$$

Again individual terms are examined for cancellations.

$$\begin{aligned}\bar{F}(\hat{x}, \theta, u) - F_{\alpha}(\hat{x}, \hat{\theta}, u) &= \begin{bmatrix} A + E(\theta) & R(\hat{x}) + Q(u) \\ 0 & 0 \end{bmatrix} - \begin{bmatrix} A + \alpha E(\hat{\theta}) & (1 - \alpha)R(\hat{x}) + Q(u) \\ 0 & 0 \end{bmatrix} \\ &= \begin{bmatrix} E(\theta) - \alpha E(\hat{\theta}) & \alpha R(\hat{x}) \\ 0 & 0 \end{bmatrix}\end{aligned}$$

Similarly,

$$\begin{aligned}\bar{H}(\hat{x}, \theta) - H_{\beta}(\hat{x}, \hat{\theta}) &= [C + D(\theta) \quad U(\hat{x})] - [C + \beta D(\hat{\theta}) \quad (1 - \beta)U(\hat{x})] \\ &= [D(\theta) - \beta D(\hat{\theta}) \quad \beta U(\hat{x})]\end{aligned}$$

We have been considering Case 1, with $\alpha = \beta = 0$, i.e.

$$\bar{F}(\hat{x}, \theta, u) - F_{\alpha}(\hat{x}, \hat{\theta}, u) = \begin{bmatrix} E(\theta) & 0 \\ 0 & 0 \end{bmatrix}$$

and

$$\bar{H}(\hat{x}, \theta) - H_{\beta}(\hat{x}, \hat{\theta}) = [D(\theta) \quad 0]$$

Thus

$$S(\theta, \hat{x}, \hat{\theta}, u) = - \left\{ \begin{bmatrix} E(\theta) & 0 \\ 0 & 0 \end{bmatrix} - K_f(\hat{x}, \hat{\theta}, u) [D(\theta) \quad 0] \right\} \quad (4.151)$$

and (4.144) can be expressed as:

$$\dot{L} = -e' \left\{ S(\theta, \hat{x}, \hat{\theta}, u)' P^{-1} - P^{-1} S(\theta, \hat{x}, \hat{\theta}, u) + \bar{H}'(\hat{x}, \hat{\theta}) V^{-1} \bar{H}(\hat{x}, \hat{\theta}) + P^{-1} W P^{-1} \right\} e$$

In this case, the matrix function S is not linear in e_{θ} as in the EKF, it is linear in θ and

can be represented

$$S(\theta, \hat{x}, \hat{\theta}, u) = X(\hat{x}, \hat{\theta}, u) \theta$$

Thus, we have

$$\dot{L} = -e' \left\{ P^{-1} (K(t) V K'(t) + W) P^{-1} - \theta' X' P^{-1} - P^{-1} X \theta \right\} e$$

Thus the new filter appears to be less stable than the EKF, in that the indefinite terms are proportional to the parameter vector itself, rather than the parameter error vector.

Nevertheless, the same indication of stability applies, in a region where the indefinite term is dominated by the positive definite term.

4.5.5.3 Stability When all Unknown Parameters Multiply the Control Input

Theorem 4-5 – If the system (4.117)-(4.118) is such that only the input distribution matrix $G(\theta)$ depends on the unknown parameter vector, $E(\theta)$ and $D(\theta)$ are both zero, and it is persistently excited such that the conditions for observability and controllability are met, then the new nonlinear filter, (4.129)-(4.130), is globally asymptotically stable.

Proof Since $E(\theta)$ and $D(\theta)$ are zero, $S = 0$ and (4.146) reduces to

$$\dot{L} = -e' \{ P^{-1} (K(t)VK'(t) + W) P^{-1} \} e$$

which is semi-definite, positive for all e , given the assumed observability and controllability of the system. Bounds on the candidate Lyapunov function and its time derivative can be shown to exist. Thus, by Lyapunov's 2nd theorem (Sec. 2.1.1, Theorem 2-1), the filter is globally asymptotically stable. \square

This is not surprising because when both $E(\theta)$ and $D(\theta)$ are zero, the system class moves back into the more restricted System Class B, and for this class the new filter is equivalent to the standard full-order Kalman filter, which is guaranteed to be stable globally.

CHAPTER 5

EXAMPLES

5.1 Comparison of All Methods in a Simple Example

The existing methods and the new methods reported herein are compared in this section by applying each to a simple 2nd order linear, time-invariant, single-input, single-output uncertain system:

$$\frac{y}{u} = \frac{\theta_1}{s(s + \theta_2)} \quad (5.1)$$

When expressed in state variable form

$$\dot{x}_1 = x_2 - \theta_2 y(t)$$

$$\dot{x}_2 = \theta_1 u(t)$$

it is clear that this system falls into Class B. The parameters $\theta_1 = 1$ and $\theta_2 = 0.1$ are both unknown. At $t = 30$ seconds, θ_2 experiences a step change to 0.20.

Existing methods that are applied are (1) the full-order Kalman filter, (2) the reduced-order Kalman filter of Section 3.2.1, (3) Narendra and Annaswamy's method of Section 3.2.2, (4) Bastin and Gevers' method of Section 3.2.3 and (5) Raghavan's method of Section 3.2.4. The new methods applied include (1) the Separate-bias Reduced-order Kalman filter of Section 4.1, and (2) the Nonlinear Observer 1 of Section 4.2. Nonlinear Observer 2 of Section 4.3 was attempted, however, without success (see Section 5.1.8). Neither the new SDDRE filter nor the EKF were applied, because for this problem they are identical to the full-order Kalman filter. In all cases a similar reasonable effort was applied to produce the filter. In some, more time could have been spent adjusting filter gains to produce better performance; however, it was felt that an accurate comparison

should also consider the level of effort required to generate the filter. The application of an (approximately) equal amount of time spent on each thus eliminates that variability.

In all cases, simulations were run with zero initial conditions on the state, the state estimate, and the parameter estimates:

$$\begin{aligned}x_1(0) = x_2(0) = 0 \quad \hat{x}_1(0) = \hat{x}_2(0) = 0 \\ \hat{\theta}_1(0) = \hat{\theta}_2(0) = 0\end{aligned}$$

although, the state estimate \hat{x}_1 does not exist in some examples involving reduced-order observers. In all cases the same persistently exciting control

$$u(t) = \sin(2\pi 0.5t) + \sin(2\pi 0.2t)$$

was applied.

5.1.1 Full-order Kalman Filter

To apply the full-order Kalman filter, the state and parameter vectors are appended, creating the dynamic system:

$$\begin{bmatrix} \dot{x}_1 \\ \dot{x}_2 \\ \dot{\theta}_1 \\ \dot{\theta}_2 \end{bmatrix} = \begin{bmatrix} 0 & 1 & 0 & -y(t) \\ 0 & 0 & u(t) & 0 \\ 0 & 0 & 0 & 0 \\ 0 & 0 & 0 & 0 \end{bmatrix} \begin{bmatrix} x_1 \\ x_2 \\ \theta_1 \\ \theta_2 \end{bmatrix} + \begin{bmatrix} w_1 \\ w_2 \\ w_3 \\ w_4 \end{bmatrix} \quad (5.2)$$

$$y = x_1 + v$$

The white process and measurement noise processes, although assumed to be zero, are shown in these equations because of their association with the noise spectral density matrices W and V of the Kalman filter. Both are chosen, or tuned, to produce the desired filter response.

Results The observer equations in this case are:

$$\dot{P} = AP + PA' - PC'V^{-1}CP + W$$

$$K = PC'V^{-1}$$

$$\dot{\hat{z}} = A(t)\hat{z} + K(y - C\hat{z})$$

where $C = [1 \ 0 \ 0 \ 0]$. The following initial state estimate covariance matrix $P(0)$, and noise density matrices:

$$W = \text{diag}[0 \ 10 \ 100 \ 100] \quad V = 0.1 \quad P(0) = \begin{bmatrix} 1 & 0 & 0 & 0 \\ 0 & 1 & 0 & 0 \\ 0 & 0 & 1 & 0 \\ 0 & 0 & 0 & 1 \end{bmatrix}$$

give the results shown in Figure 5.1.

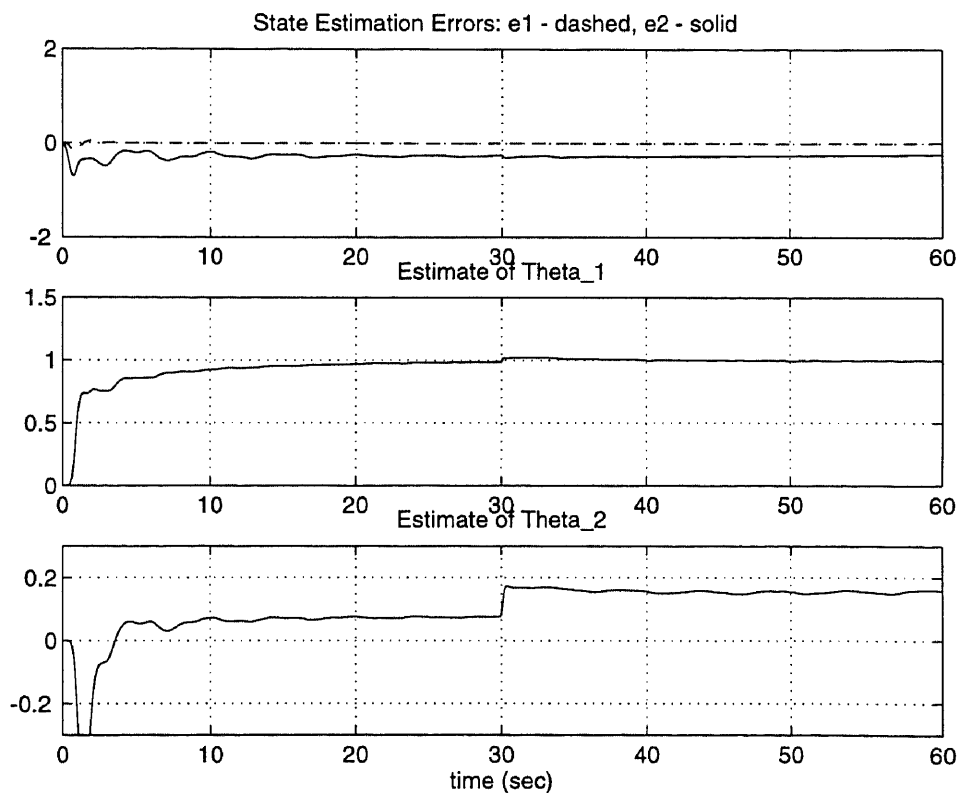

Figure 5.1 Full-Order Kalman Filter

Remarks As can be seen by the simplicity of the filtering equations, this observer is easy to implement and, like the Kalman filter for time invariant systems, intuitive. The computational load, on the other hand, is relatively high, involving a total of 14 coupled differential equations. The parameter estimates converges fairly well, and the change in θ_2 is detected. Although the convergence in the estimate of x_2 is poor, presumably the response could be improved by better tuning of the design parameters in W and V .

5.1.2 Reduced-Order Kalman Filter

Observer Equations The Reduced-order Kalman filter (see Eq. (5.2)) involves the submatrices:

$$\bar{A}_{11} = 0 \quad \bar{A}_{12} = [1 \quad 0 \quad -y(t)] \quad \bar{A}_{21} = \begin{bmatrix} 0 \\ 0 \\ 0 \end{bmatrix} \quad \bar{A}_{22} = \begin{bmatrix} 0 & u(t) & 0 \\ 0 & 0 & 0 \\ 0 & 0 & 0 \end{bmatrix}$$

and the following constant matrices:

$$F_1 = [1 \quad 0 \quad 0 \quad 0] \quad F_2 = \begin{bmatrix} 0 & 1 & 0 & 0 \\ 0 & 0 & 1 & 0 \\ 0 & 0 & 0 & 1 \end{bmatrix} \quad Q = \begin{bmatrix} 1 & 0 & 0 & 0 \\ 0 & 1 & 0 & 0 \\ 0 & 0 & 1 & 0 \\ 0 & 0 & 0 & 1 \end{bmatrix}$$

where Q is the process noise spectral density matrix selected for this simulation.

The observer equations updated in continuous time are given by:

$$\begin{aligned} \tilde{A} &= A_{22} - F_2 Q F_1' W^{-1} A_{12} \\ \dot{P} &= \tilde{A} P + P \tilde{A}' - P A_{12}' W^{-1} A_{12} P + F_2 \tilde{Q} F_2' \\ \dot{A}_{12} &= [0 \quad 0 \quad -\dot{y}] \\ K &= (P A_{12}' + F_2 Q F_1') W^{-1} \end{aligned}$$

$$\dot{K} = (\dot{P}A'_{12} + PA'_{12})W^{-1}$$

$$\hat{x}_2 = x_2 + Ky$$

$$\dot{z} = (A_{22} - KA_{12})\hat{x}_2 - \dot{K}y$$

where the initial conditions for z and P given by:

$$z(0) = \begin{bmatrix} 0 & 0 & 0 \end{bmatrix} \quad P(0) = \begin{bmatrix} 1 & 0 & 0 \\ 0 & 1 & 0 \\ 0 & 0 & 1 \end{bmatrix}$$

The response with this filter are shown in Figure 5.2.

Remarks When compared to the full-order Kalman filter, computational loading in this example is lessened from 14 to 9 coupled equations. Nevertheless, transient performance is very similar. Convergence of $\hat{\theta}_2$ is poor, however, which in turn produced a hangoff error in \hat{x}_2 . Again, better tuning probably could help.

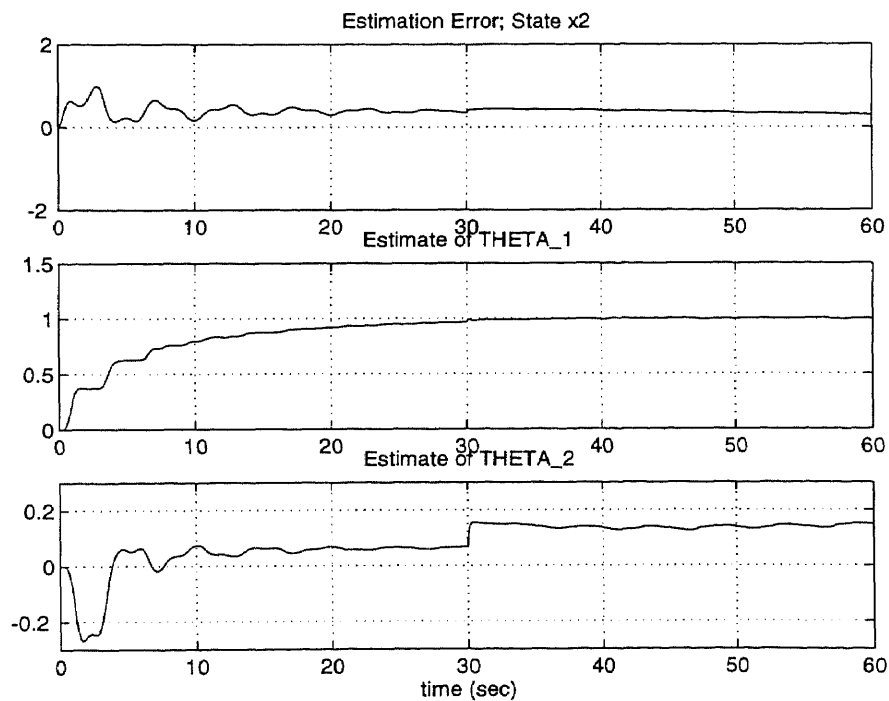

Figure 5.2 Reduced-Order Kalman Filter

5.1.3 Narendra and Annaswamy's Observer

For this example problem the Narendra and Annaswamy observer is:

$$\dot{\hat{x}}_1 = -\hat{x}_1 + \hat{\theta}'\hat{\omega}, \quad \hat{x}_1(0) = 0$$

$$\dot{\hat{\omega}}_1 = -0.1\hat{\omega}_1 + u, \quad \hat{\omega}_1(0) = 0$$

$$\dot{\hat{\omega}}_2 = -0.1\hat{\omega}_2 + y, \quad \hat{\omega}_2(0) = 0$$

$$e = \hat{y} - y$$

$$\dot{\hat{\theta}} = -e\Gamma\hat{\omega}$$

with $\hat{\omega} = [u \quad \hat{\omega}_1 \quad y \quad \hat{\omega}_2]$. In the simulation results of Figure 5.3, the following

parameters were employed:

$$\lambda = 1.$$

$$\Lambda = 0.1$$

$$\Gamma = 10I_2$$

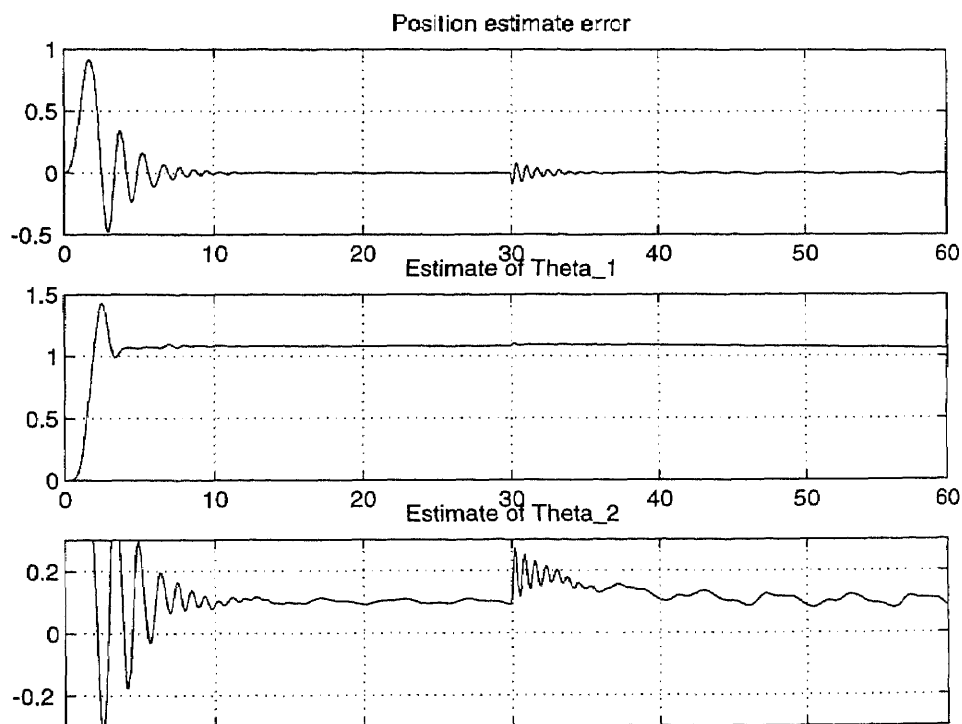

Figure 5.3 Narendra and Annaswamy's Adaptive Observer

Remarks. The filter given above is 4th order. Thus, computational loading is significantly less than both the full-order (14th order) and reduced-order (9th order) Kalman filters. However, the performance of this filter is significantly different from the previous two. The position estimation error does not contain a hangoff as did the previous two, which is good. However, the transient swings are larger and the change in θ_2 is not accurately estimated. Also, θ_1 is not estimated very accurately.

5.1.4 Bastion and Gevers' Observer

The Bastion and Gevers method requires the system to be of the form

$$\dot{x} = Rx + \Omega(t)\theta + g(t)$$

where R is a stable, constant Hurwitz matrix. We convert (5.1), repeated here in state-space form:

$$\begin{bmatrix} \dot{x}_1 \\ \dot{x}_2 \end{bmatrix} = \begin{bmatrix} 0 & 1 \\ 0 & 0 \end{bmatrix} \begin{bmatrix} x_1 \\ x_2 \end{bmatrix} + \begin{bmatrix} 0 & -y \\ u & 0 \end{bmatrix} \begin{bmatrix} \theta_1 \\ \theta_2 \end{bmatrix}$$

to the required form through the change in coordinates:

$$\begin{bmatrix} z_1 \\ z_2 \end{bmatrix} = \begin{bmatrix} 1 & 0 \\ c_2 & 1 \end{bmatrix} \begin{bmatrix} x_1 \\ x_2 \end{bmatrix}$$

with c_2 a positive constant. The system dynamics in this coordinate system:

$$\begin{bmatrix} \dot{z}_1 \\ \dot{z}_2 \end{bmatrix} = \begin{bmatrix} 0 & 1 \\ 0 & -c_2 \end{bmatrix} \begin{bmatrix} z_1 \\ z_2 \end{bmatrix} + \begin{bmatrix} 0 & -y \\ u & c_2 y \end{bmatrix} \begin{bmatrix} \theta_1 \\ \theta_2 \end{bmatrix} + \begin{bmatrix} c_2 \\ -c_2^2 \end{bmatrix} y$$

clearly has the form that is required.

In accordance with the Bastion and Gevers' observer definition as given in [3] and in Section 3.2.3 the following observer equations are derived:

State Equations:

$$\begin{bmatrix} \dot{\hat{z}}_1 \\ \dot{\hat{z}}_2 \end{bmatrix} = \begin{bmatrix} 0 & 1 \\ 0 & -c_2 \end{bmatrix} \begin{bmatrix} \hat{z}_1 \\ \hat{z}_2 \end{bmatrix} + \begin{bmatrix} 0 & -y \\ u & c_2 y \end{bmatrix} \begin{bmatrix} \hat{\theta}_1 \\ \hat{\theta}_2 \end{bmatrix} + \begin{bmatrix} c_2 \\ -c_2^2 \end{bmatrix} y + \begin{bmatrix} c_1 e \\ V_1 \dot{\hat{\theta}}_1 + V_2 \dot{\hat{\theta}}_2 \end{bmatrix}$$

Parameter Observer:

$$\dot{\hat{\theta}}_1 = \gamma_1 V_1 e$$

$$\dot{\hat{\theta}}_2 = \gamma_2 (V_2 - y) e$$

Auxiliary Equations:

$$\dot{V}_1 = -c_2 V_1 + u \quad V_1(0) = 0$$

$$\dot{V}_2 = -c_2 V_2 + c_2 y \quad V_2(0) = 0$$

The simulation results shown below were run with $\gamma_1 = \gamma_2 = c_1 = c_2 = 1$.

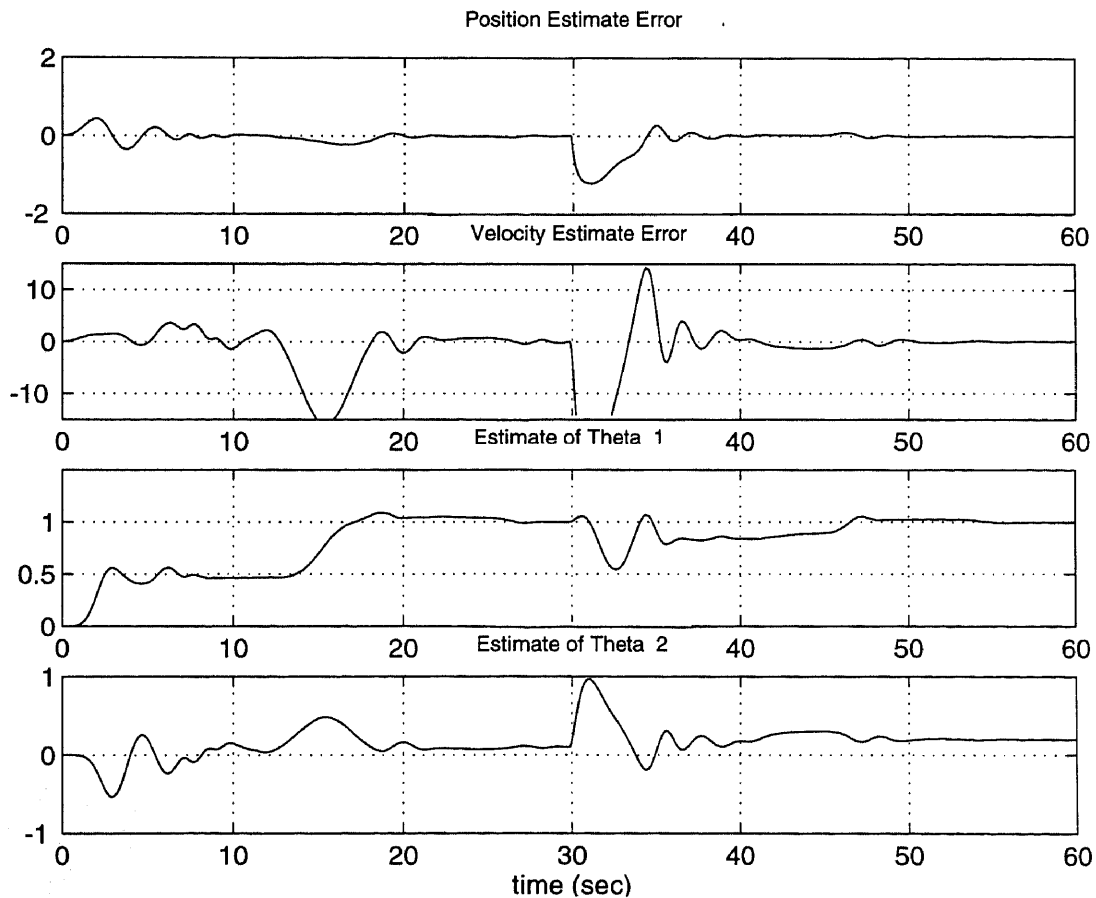

Figure 5.4 Bastion and Gevers' Adaptive Observer

Remarks In this case computational loading is moderate; the observer is 6th order.

Although transient swings are large like Narandra and Annaswamy's observer, there is less ringing, and good convergence does eventually occur. It appears to be better than all of the observers discussed thus far, and it appears to be fairly robust in that it accurately tracks the change in θ_2 that occurs at $t = 30$ seconds. The change does cause, however, excessive swings in all of the estimates.

5.1.5 Raghavan's Observer

Raghavan's adaptive observer is most easily expressed in matrix form, even for this simple example. Thus, for this 2nd order example, the observer equations are:

$$\begin{aligned}\hat{x} &= \xi + \Psi \hat{\theta} \\ \dot{\xi} &= (A - LC)\xi + Ly & \xi(0) &= [0 \ 0]' \\ \dot{\Psi} &= (A - LC)\Psi + \beta(t) & \Psi(0) &= 0_{4 \times 4} \\ \dot{\hat{\theta}} &= k\Psi' C'(y - C\hat{x})\end{aligned}$$

where $L = [l_1 \ l_2]$ and $k = \begin{bmatrix} k_{11} & k_{12} \\ k_{21} & k_{22} \end{bmatrix}$ are the design parameters, and where the various

system matrices are given by the plant expressed in the necessary form:

$$\begin{bmatrix} \dot{x}_1 \\ \dot{x}_2 \end{bmatrix} = \begin{bmatrix} 0 & 1 \\ 0 & 0 \end{bmatrix} \begin{bmatrix} x_1 \\ x_2 \end{bmatrix} + \begin{bmatrix} 0 & -y \\ u & 0 \end{bmatrix} \begin{bmatrix} \theta_1 \\ \theta_2 \end{bmatrix}$$

$y = [1 \ 0]x$

The simulation results below were generated with $l_1 = l_2 = 0.1$ and $k = I_2$.

Remarks This observer is 8th order. Transient swings, shown in Figure 5.5, are large, but not as large as those produced by the Bastin and Gevers' filter. The convergence is

strong, somewhat better than the other observers discussed thusfar. The change in θ_2 is accurately tracked.

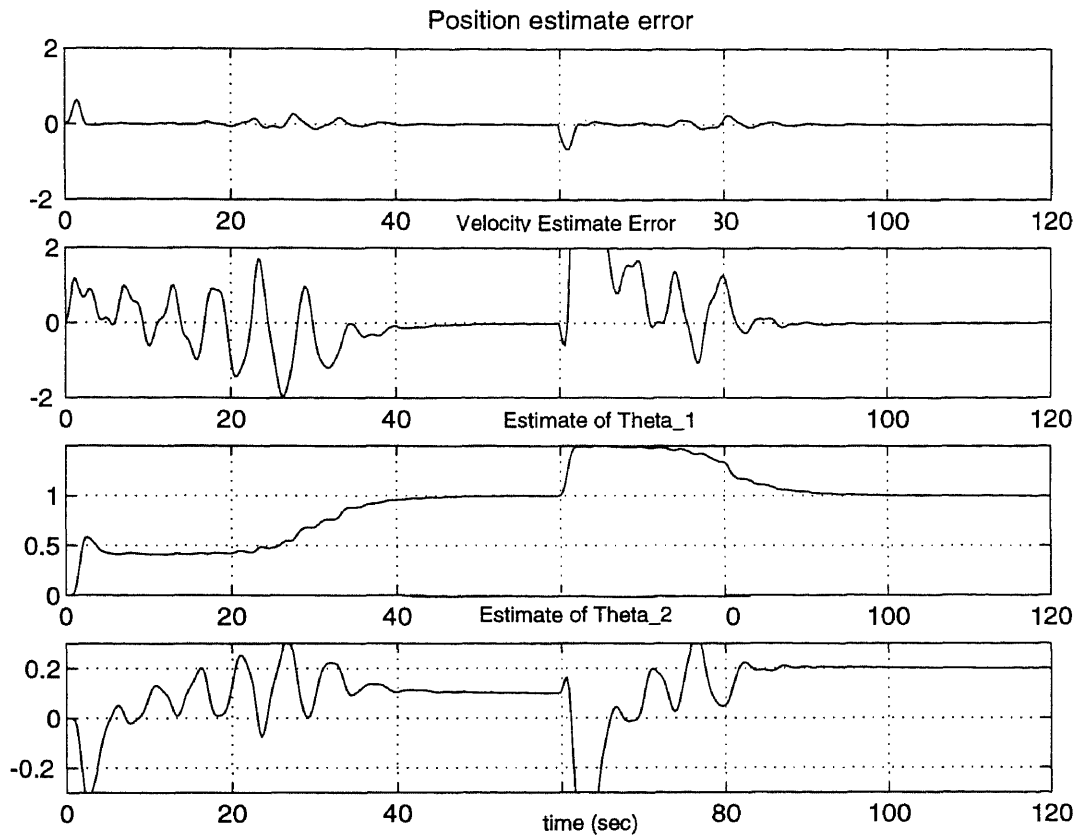

Figure 5.5 Raghavan's Adaptive Observer

5.1.6 Reduced-Order Separate-Bias Kalman Filter

The Reduced-Order Separate-Bias Kalman filter of Section 3.2.1, when applied to system (5.1), is expressed as follows:

Bias-Free Filter:

$$\dot{p} = -p^2 / q_{11} \quad p(0) = 1$$

$$\tilde{K} = (p + q_{12}) / q_{11}$$

$$\dot{\tilde{K}} = \dot{p} / q_{11}$$

$$\begin{aligned}\dot{\tilde{z}} &= -\tilde{K}\tilde{x}_2 - \tilde{K}y & \tilde{z}(0) &= 0 \\ \tilde{x}_2 &= \tilde{z} + \tilde{K}y\end{aligned}$$

Separate-Bias Filter:

$$\begin{aligned}E_1 &= [0 \quad -y] \\ E_2 &= [u \quad 0] \\ \dot{S} &= -\tilde{K}S + E_2 - \tilde{K}E_1 & S(0) &= [0 \quad 0] \\ \dot{M} &= -M(S' + E_1')(S + E_1)M / q_{11} & M(0) &= I_2 \\ K_2 &= M(S' + E_1') / q_{11} \\ \hat{b} &= z_2 + K_2 y \\ \hat{x}_2 &= \tilde{x}_2 + S\hat{b} \\ \dot{K}_2 &= \dot{M}(S' + E_1') / q_{11} + M(\dot{S}' + \dot{E}_1') / q_{11} \\ \dot{E}_1 &= [0 \quad -\dot{y}] \\ \dot{z}_2 &= -K_2(\tilde{x}_2 + (E_1 + S)\hat{b}) - \dot{K}_2 y & z_2(0) &= [0 \quad 0]\end{aligned}$$

with a process spectral density matrix of

$$Q = \begin{bmatrix} q_{11} & q_{12} \\ q_{12} & q_{22} \end{bmatrix} = \begin{bmatrix} 1 & 0 \\ 0 & 1 \end{bmatrix}$$

the system performance is as shown in Figure 5.6.

Remarks This filter is 9th order. Very good convergence is achieved initially, however, the change in θ_2 is not tracked very well. Again, with additional tuning it would probably be possible to improve tracking through a parameter change. Presumably a system such as this would be well served by the addition of a failure detection mechanism.

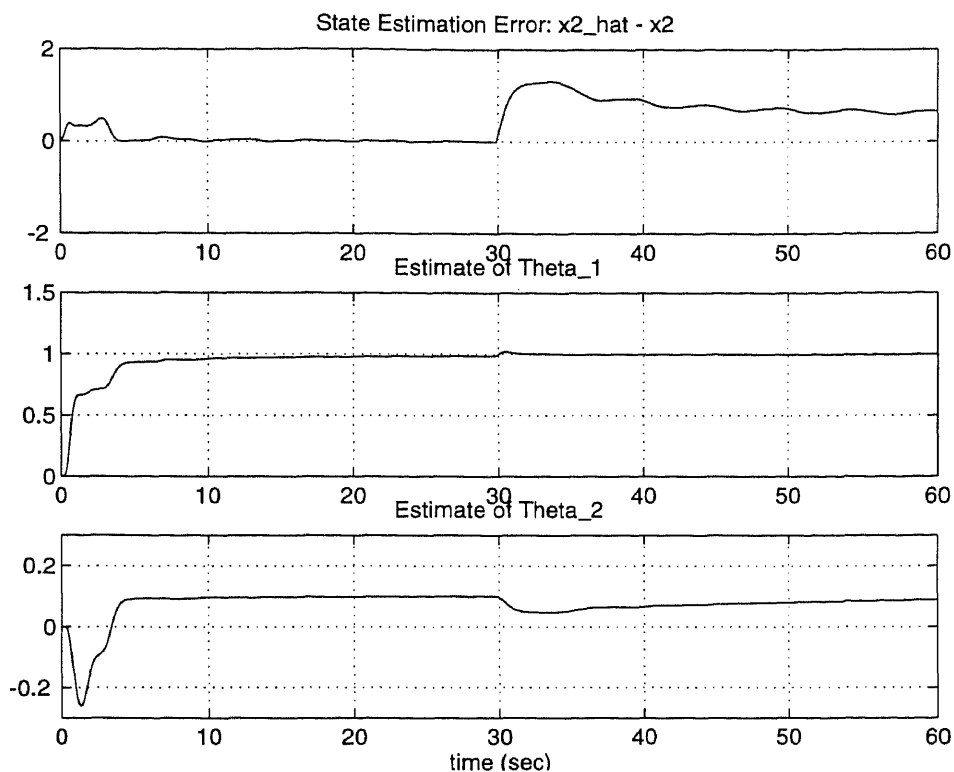

Figure 5.6 Reduced-Order Separate Bias Kalman Filter

5.1.7 Nonlinear Observer 1

The submatrices that are needed to construct this reduced-order filter are in this example:

$$\begin{aligned}
 A_{11} = A_{21} = A_{22} = 0 & & g_1 = g_2 = 0 & & A_{12} = 1 \\
 E_1(t) = [0 \quad -y] & & E_2(t) = [u \quad 0]
 \end{aligned}$$

Given these, the straightforward application of equations (4.63)-(4.67) yields:

$$\begin{aligned}
 \hat{x}_2 &= \hat{z} + Ly \\
 \hat{z} &= \xi + \Psi \hat{\theta} \\
 \dot{\xi} &= -L(\xi + Ly) & \xi(0) &= \hat{x}_2(0) = 0 \\
 \dot{\Psi} &= -L\Psi + [u \quad -y] & \Psi(0) &= [0 \quad 0] \\
 \dot{\hat{\theta}} &= [\Psi' + E_1'] \{ \dot{y} - \hat{x}_2 + y \hat{\theta}_2 \} & \hat{\theta}(0) &= [0 \quad 0]' \quad (5.3)
 \end{aligned}$$

In the last equation you will note the presence of \dot{y} , which should be eliminated if possible. The elimination of \dot{y} depends on the success one has in finding a vector function $\phi(t)$ having the jacobian

$$\Phi_y = \Psi' A_{12} + E_1'$$

which in this example is $\Phi_y = [\psi_1 \quad \psi_2 - y]$ where $\Psi = [\psi_1 \quad \psi_2]$. It is easy to verify that one such vector function is the following:

$$\phi(t, u, y) = \begin{bmatrix} \psi_1 y \\ \psi_2 y - \frac{1}{2} y^2 \end{bmatrix}$$

Thus, given the above, it is possible to generate the other jacobians needed in Equation (4.71)

$$\Phi_u(t, u, y) = \frac{\partial \phi(t, u, y)}{\partial u} = \begin{bmatrix} 0 \\ 0 \end{bmatrix} \quad \Phi_y(t, u, y) = \frac{\partial \phi(t, u, y)}{\partial y} = \begin{bmatrix} \psi_1 \\ \psi_2 \end{bmatrix} y$$

which upon substitution into Equation (4.70) yields

$$\hat{\theta} = \begin{bmatrix} \psi_1 y \\ \psi_2 y - \frac{1}{2} y^2 \end{bmatrix} + z_\theta$$

$$\dot{z}_\theta = [\Psi' + E_1'](-\hat{x}_2 + y\hat{\theta}_2) - y\dot{\Psi}'$$

These two equations replace the parameter update equation (5.3) given above.

Remarks This filter is of order 5, which is 3 less than Raghavan's. In comparison, one state estimate and two elements from the $\dot{\Psi}$ matrix differential equation are removed.

Performance appears to be much better than the full-order Raghavan observer in this test case, in that the large transients and long settling times have been significantly reduced.

In addition, the step change in θ_2 is tracked well without causing large swings in the other estimates.

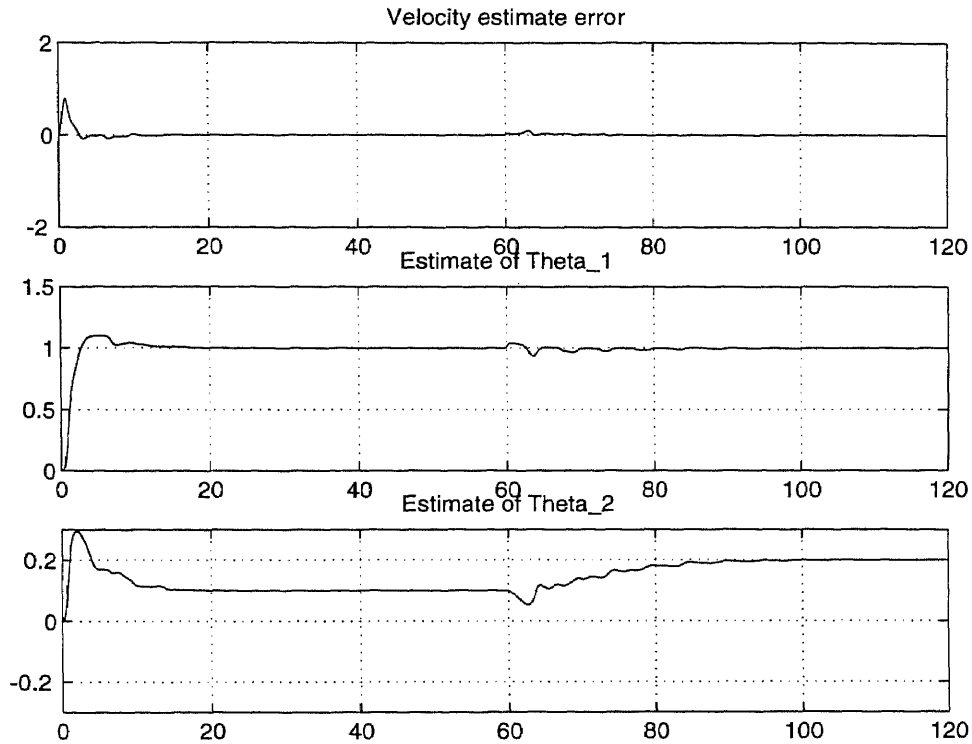

Figure 5.7 Nonlinear Observer 1

5.1.8 Nonlinear Observer 2

Friedland's observer when applied to this example yields error dynamics:

$$\begin{bmatrix} \dot{e}_{x_2} \\ \dot{e}_{\theta_1} \\ \dot{e}_{\theta_2} \end{bmatrix} = \begin{bmatrix} K & -u & -Ky \\ L_1 & 0 & L_1 y \\ L_2 & 0 & L_2 y \end{bmatrix} \begin{bmatrix} e_{x_2} \\ e_{\theta_1} \\ e_{\theta_2} \end{bmatrix}$$

with K , L_1 and L_2 constants. There is no choice of constants that can produce a symmetric matrix, thus (4.87) cannot be satisfied. One could proceed with the application of this filter anyway, however there would be no guarantee of convergence.

5.1.9 Summary of Results and Discussion

The key observations to be made about the various methods applied in this simple test example are summarized in Table 5.1. In general, all of the methods converged, as they should since global asymptotic stability is, for this class of system, guaranteed by all of these methods. Some, however, performed significantly better than others. All of the Kalman filter based methods did a good job in estimating the initial parameter values, but did not do too well in tracking the change in θ_2 . The Narandra-Annaswamy observer performed similarly, tracking the initial values well and the change in θ_2 poorly. This filter, however, has the added disadvantage of being somewhat more difficult to apply. Those filters that estimated the initial values correctly and tracked the change in θ_2 well were the Bastion-Gevers filter, the Raghavan filter, and the Nonlinear Observer 1. The advantage that the Nonlinear Observer 1 has over the others appears to be the much reduced transient swings that occur initially and after the step change in θ_2 . In addition, it also has the lowest order of the three.

Table 5.1.1 Summary of Results, All Methods in a Simple Example

Method	Order	Transients	Tracking of θ_2 Change	Ease of Application
Existing Methods:				
Full-order Kalman Filter	14	good	poor	2
Reduced-order Kalman Filter	9	good	poor	2
Narendra-Annaswamy	4	poor	poor	3
Bastion-Gevers	6	poor	good	3
Raghavan	8	better	good	1
New Methods:				
Separate-bias Reduced-order Kalman filter	9	good	poor	2
Nonlinear Observer 1	5	good	good	1
Nonlinear Observer 2	3	n/a	n/a	n/a

Ease of Application Key: 1 – Easy, with little tuning required; 2 – Moderate, with some tuning required; 3 – Difficult, requiring a preliminary transformation to proper form

5.2 Stepper Motor Example

The new SDDRE nonlinear filtering technique developed in the previous chapter for systems bilinear in their unknown parameters and state variables (i.e. System Class C) and the Extended Kalman Filter (EKF), are applied in this section to a parameter estimation problem involving a 4th order permanent magnet stepper motor with six (6) unknown parameters. Through simulation experiments, we demonstrate that the performance of both are stable. Not only do both filters generate convergent state and parameter estimates, but the results indicate that a region of convergence exists and that

region appears to be at least semi-global, as indicated by the theory. Actually, a set of initial conditions leading to non-convergence could not be found.

5.2.1 Model

In [4] A.J. Blauch, et. al. demonstrate the use of a batch least-squares estimation algorithm in the identification of the parameters of a permanent magnet stepper motor.

The motor model:

$$\frac{di_d(t)}{dt} = \frac{1}{L}v_d(t) - \frac{R}{L}i_d(t) + N\omega(t)i_q(t) \quad (5.4)$$

$$\frac{di_q(t)}{dt} = \frac{1}{L}v_q(t) - \frac{R}{L}i_q(t) - N\omega(t)i_d(t) - K_m\omega(t) \quad (5.5)$$

$$\frac{d\omega(t)}{dt} = \frac{K_m}{J}i_q(t) - \frac{B}{J}\omega(t) - \frac{C}{J}\text{sgn}(\omega(t)) \quad (5.6)$$

$$\frac{d\phi(t)}{dt} = \omega(t) \quad (5.7)$$

is nonlinear, 4th order, and contains six (6) unknown parameters and two (2) inputs, all of which are defined in Table 5.2 and Table 5.3. In addition, there is a known parameter involved, N , which is related to the motor step size. As noted, the model is clearly nonlinear. Equations (5.4) and (5.5) contain the multiplication of two state variables, $\omega(t)$ and a current, and in equation (5.6) there is coulomb friction. There also exists the nonlinearity introduced by the multiplication of an unknown parameter with an unmeasured state variable (i.e. System Class C); we will be considering the case in which the viscous friction coefficient B is unknown.

Table 5.2 – State Variable and Input Definitions

Variable	Description	Units
i_q, i_d	Quadrature and Direct Currents	Amps
ω	Angular Velocity	rad/sec
θ	Angular Position	rad
v_q, v_d	Input voltages	Volts

Table 5.3 - System Parameter Definitions

Variable	Description	Units
R	Motor Winding Resistance	Ω
L	Inductance	H
K_m	Torque Constant	$N\cdot m/A$
J	Inertia	$N\cdot m\cdot s^2$
B	Viscous Friction Coefficient	$N\cdot m\cdot s$
C	Coulomb Friction Coefficient	$N\cdot m$

The measurements that will be assumed in this case study will include both phase currents, i_q and i_d , and the motor shaft position θ . This is typical in motion control applications involving stepper motors.

All of the parameters listed in Table 5.3 can have some degree of uncertainty. The inertia constant J can vary as the load being driven by the motor varies. In addition, motor viscous friction B is also typically very poorly known, more so than the motor resistance R , inductance L , and torque constant K_m . All can vary somewhat with temperature and/or time, and so all five (5) of these parameters are assumed to be unknown and requiring estimation. The coulomb friction coefficient C , on the other

hand, multiplies the hard nonlinearity, $\text{sgn}(\omega(t))$. It therefore must be considered a known if we are to satisfy the restriction of System Class C.

The following definitions:

$$\theta_1 = \frac{B}{J} \quad \theta_2 = \frac{C}{J} \quad \theta_3 = \frac{K_m}{J} \quad \theta_4 = \frac{R}{L} \quad \theta_5 = \frac{K_m}{L} \quad \theta_6 = \frac{1}{L}$$

and

$$x_1 = \phi \quad x_2 = i_d \quad x_3 = i_q \quad x_4 = \omega$$

allow the system model (5.1)-(5.4) to be expressed in the more compact form:

$$\begin{aligned} \dot{x}_1 &= x_4 \\ \dot{x}_2 &= \theta_6 v_d - \theta_4 x_2 + N x_4 x_3 \\ \dot{x}_3 &= \theta_6 v_q - \theta_4 x_3 - \theta_5 x_4 - N x_4 x_2 \\ \dot{x}_4 &= \theta_3 x_3 - \theta_1 x_4 - \theta_2 \text{sgn}(x_4) \end{aligned} \quad (5.8)$$

The state variables (5.5) are arranged in this order so that the first three are measured,

$$\begin{bmatrix} y_1 \\ y_2 \\ y_3 \end{bmatrix} = \begin{bmatrix} x_1 \\ x_2 \\ x_3 \end{bmatrix}$$

and the remaining one is not.

Actual parameter values are listed in Table 5. 1.4. These give rise to the following true parameter values:

$$\begin{aligned} \theta_1 = \frac{B}{J} &= 4.49 & \theta_2 = \frac{C}{J} &= 61.8 & \theta_3 = \frac{K_m}{J} &= 2865. \\ \theta_4 = \frac{R}{L} &= 232.1 & \theta_5 = \frac{K_m}{L} &= 182. & \theta_6 = \frac{1}{L} &= 357. \end{aligned}$$

Table 5. 1.4 – Stepper Motor Parameter Values

R	Motor Winding Resistance	0.65 Ω
L	Inductance	0.0028 H
K_m	Torque Constant	0.51 $N\cdot m/A$
J	Inertia	0.000178 $N\cdot m\cdot s^2$
B	Viscous Friction Coefficient	0.0008 $N\cdot m\cdot s$
C	Coulomb Friction Coefficient	0.011 $N\cdot m$

5.2.2 Filter Equations

Both the SDDRE filter and the EKF simulation tested with this example depend on the system matrices $A(t)$, $E(\theta)$, $R(\theta)$, and $Q(u)$, which in this application are:

$$A(t) = \begin{bmatrix} 0 & 0 & 0 & 1 \\ 0 & 0 & 0 & Ny_3 \\ 0 & 0 & 0 & -Ny_2 \\ 0 & 0 & 0 & 0 \end{bmatrix} \quad E(\theta) = \begin{bmatrix} 0 & 0 & 0 & 0 \\ 0 & -\theta_4 & 0 & 0 \\ 0 & 0 & -\theta_4 & -\theta_5 \\ 0 & 0 & \theta_3 & -\theta_1 \end{bmatrix}$$

$$R(x) = \begin{bmatrix} 0 & 0 & 0 & 0 & 0 & 0 \\ 0 & 0 & 0 & -x_2 & 0 & 0 \\ 0 & 0 & 0 & -x_3 & -x_4 & 0 \\ -x_4 & -\text{sgn}(x_4) & x_3 & 0 & 0 & 0 \end{bmatrix} \quad Q(u) = \begin{bmatrix} 0 & 0 & 0 & 0 & 0 & 0 \\ 0 & 0 & 0 & 0 & 0 & v_d \\ 0 & 0 & 0 & 0 & 0 & v_q \\ 0 & 0 & 0 & 0 & 0 & 0 \end{bmatrix}$$

These define the State Dependent Coefficient (SDC) representation for the augmented

system :

$$\begin{bmatrix} x_1 \\ x_2 \\ x_3 \\ x_4 \\ \theta_1 \\ \theta_2 \\ \theta_3 \\ \theta_4 \\ \theta_5 \\ \theta_6 \end{bmatrix} = \begin{bmatrix} 0 & 0 & 0 & 1 & 0 & 0 & 0 & 0 & 0 & 0 \\ 0 & -\alpha\theta_4 & \alpha Nx_4 & \alpha Nx_3 & 0 & 0 & 0 & -(1-\alpha)x_2 & 0 & v_d \\ 0 & -\alpha Nx_4 & -\alpha\theta_4 & -\alpha(\theta_5 + Nx_2) & 0 & 0 & 0 & -(1-\alpha)x_3 & -(1-\alpha)x_4 & v_q \\ 0 & 0 & \alpha\theta_3 & -\alpha\theta_1 & -(1-\alpha)x_4 & -\text{sgn}(x_4) & (1-\alpha)x_3 & 0 & 0 & 0 \\ 0 & 0 & 0 & 0 & 0 & 0 & 0 & 0 & 0 & 0 \\ 0 & \ddots & & & & & & & & \\ 0 & & & & & & & & & \\ 0 & & & & & & & & & \\ 0 & & & & & & & & & \\ 0 & & & & & & & & & \\ 0 & & & & & & & & & 0 \end{bmatrix} \begin{bmatrix} x_1 \\ x_2 \\ x_3 \\ x_4 \\ \theta_1 \\ \theta_2 \\ \theta_3 \\ \theta_4 \\ \theta_5 \\ \theta_6 \end{bmatrix} \quad (5.9)$$

Thus, the matrix in (5.9) is $F_\alpha(z)$. In the simulations that follow, a value of $\alpha = 0.5$ was used. The observation matrix $H_\beta(z)$ is given by

$$H_\beta(z) = [I_3 \quad 0_{7 \times 7}]$$

In the EKF, the needed jacobians \bar{F} and \bar{H} are constructed in a similar fashion using the matrices $A(t)$, $E(\theta)$, $R(\theta)$, and $Q(u)$, and will not be shown here. The observation jacobian, $\bar{H} = H_\beta$.

5.2.3 Simulation Conditions

The initial conditions for applied in this simulation experiment were the following:

$$\begin{aligned} P(0) &= 0_{10 \times 10} & x(0) &= 0_{4 \times 1} & \hat{x}(0) &= 0_{4 \times 1} \\ \hat{\theta}_1(0) &= 0 & \hat{\theta}_2(0) &= 0 & \hat{\theta}_3(0) &= 0.9\theta_3 \\ \hat{\theta}_4(0) &= 2\theta_4 & \theta_5(0) &= \theta_5 & \theta(0)_6 &= 0.5\theta_6 \end{aligned}$$

A persistently exciting control action applied was in both examples:

$$\begin{aligned} v_d &= 0 \\ v_q &= 28 * \text{sign}(\sin(2\pi t / 0.04)) \end{aligned}$$

where the direct voltage is 0 and the quadrature voltage is a 28 volt, 25 Hz square wave.

The filter design matrices:

$$\begin{aligned} W &= 10^8 \text{diag}(1 \ 1 \ 1 \ 1 \ 1 \ 100 \ 1000 \ 1 \ 1 \ 1) \\ V &= I_3 \end{aligned}$$

were selected by trial and error after examining a few transient simulations. In all cases both filters were stable, however their speed of response required adjustment.

In the first simulation example, the coulomb friction coefficient C is set to a known value, *zero*. The system is then bilinear in the remaining coefficient and state variables,

thereby satisfying the constraints of System Class C, to which the proof of stability applies. The results of the first simulation, which involved perfect knowledge of the coulomb friction coefficient, are shown in Figure 5.8 through Figure 5.12 below. The oscillations that occur in all of these results are caused by the 25 Hz drive voltage excitation applied to the motor. The 50 Hz oscillation that appears in the parameter estimates is caused by the rectification that occurs due to the modulation of the filter gains at 25 Hz.

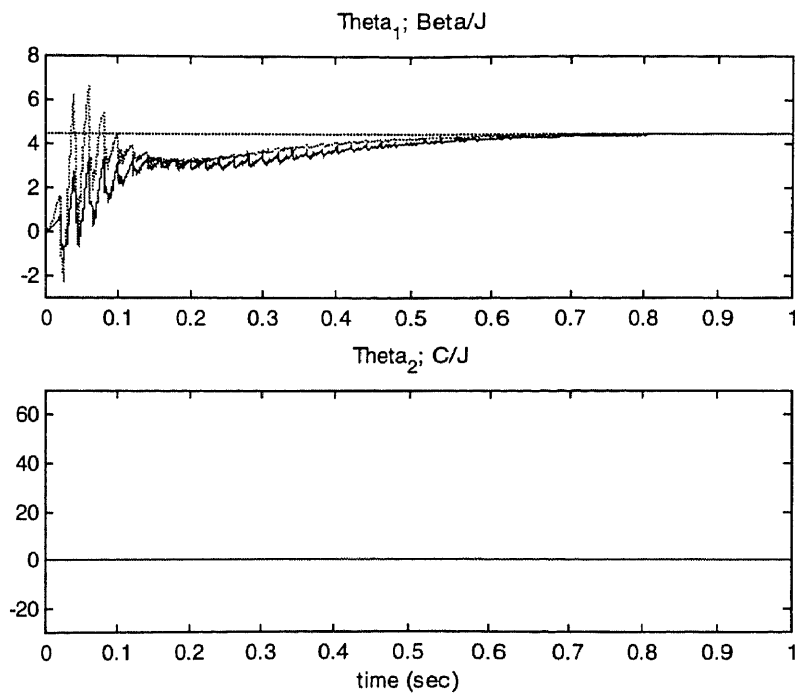

Figure 5.8 Parameter Estimates, Stepper Motor, SDDRE (solid), EKF (dotted), Coulomb Friction Known to be Zero

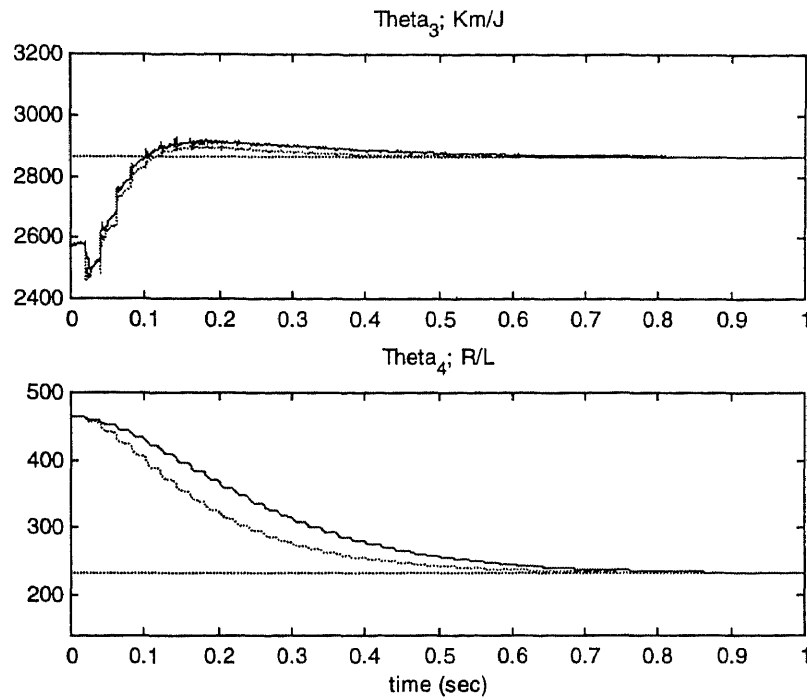

Figure 5.9 Parameter Estimates, Stepper Motor, SDDRE (solid), EKF (dotted), Coulomb Friction Known to be Zero

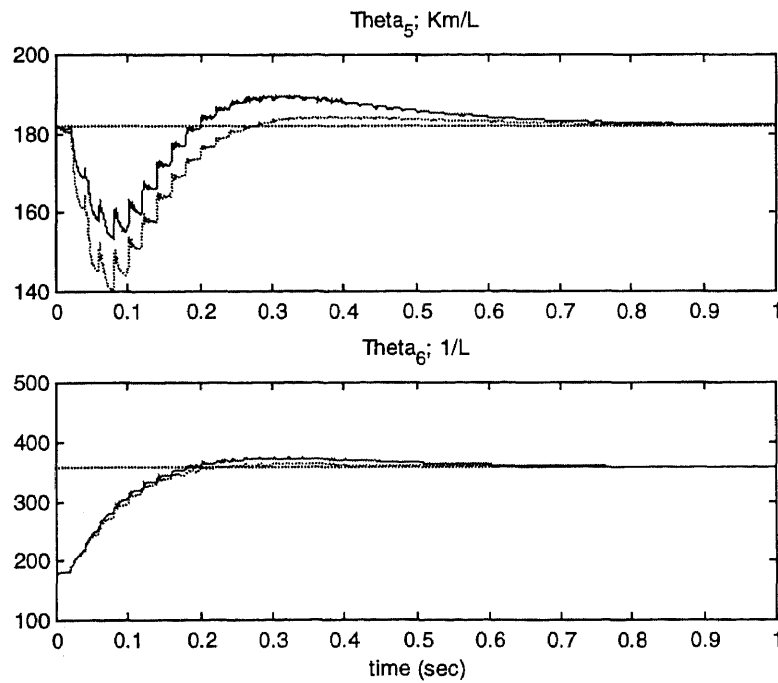

Figure 5.10 Parameter Estimates, Stepper Motor, SDDRE (solid), EKF (dotted), Coulomb Friction Known to be Zero

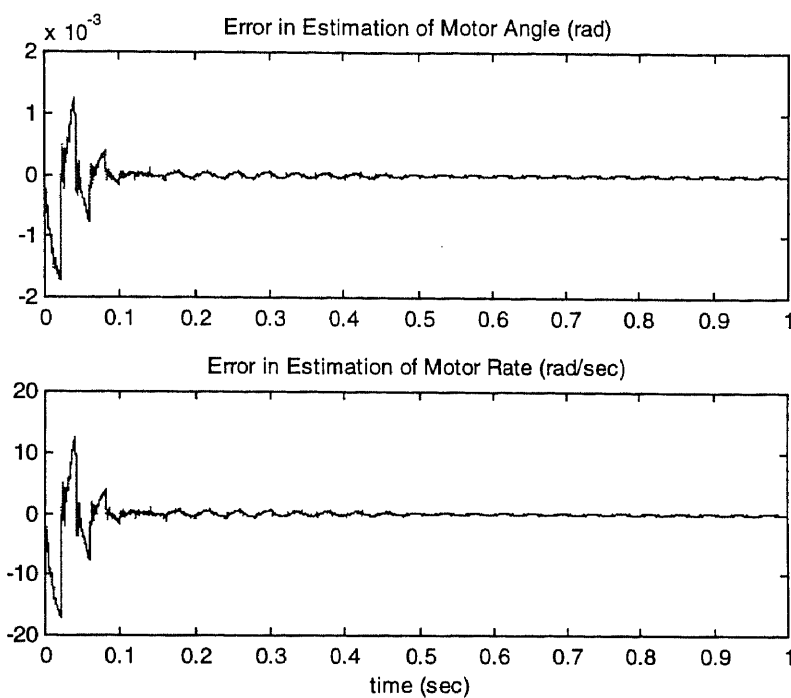

Figure 5.11 State Estimates, Stepper Motor, SDDRE (solid), EKF (dotted), Coulomb Friction Known to be Zero

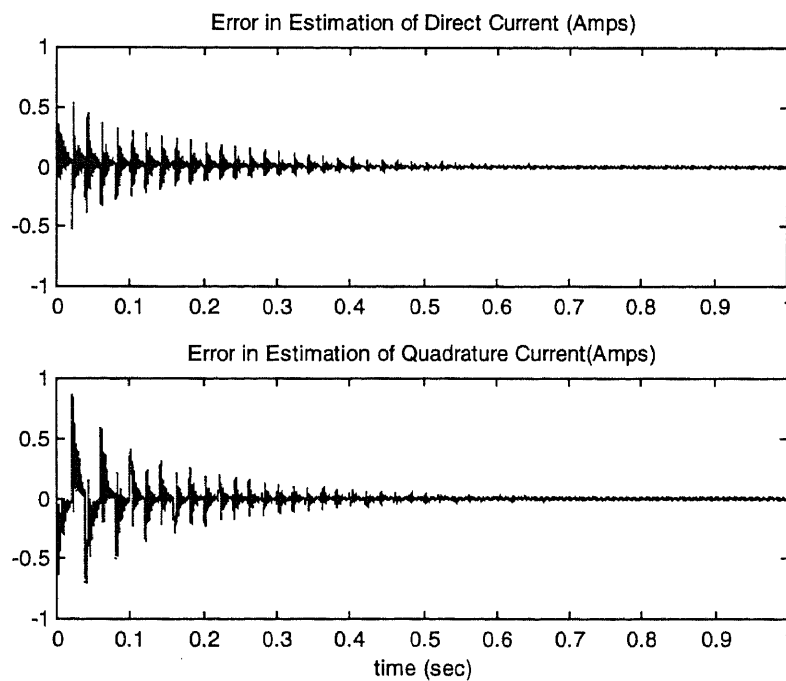

Figure 5.12 State Estimates, Stepper Motor, SDDRE (solid), EKF (dotted) Coulomb, Friction Known to be Zero

In all plots, the SDDRE filter result is plotted as a solid line and the EKF result as a dotted line. The true parameters are shown as dashed lines. Clearly, the filter estimates all converge nicely to their true values after a short transient. This occurs even though the initial parameter errors were in some cases very large. In fact, as noted, a set of initial conditions yielding unstable performance could not be found, indicating that the region of convergence is apparently large. The difference between the estimates provided by the EKF and SDDRE filter is only apparent in the parameter estimates. The states estimates are virtually identical and indistinguishable on the plots.

In the next simulation test, the viscous damping is assumed to be zero and known, and the coulomb friction C is an unknown that is estimated by the filter. These results are given in Figure 5.13 through Figure 5.17. You will note that both filters again do a excellent job in estimating the unknown states and parameters. Like the first test, initial conditions leading to instability could not be found.

Finally, in a third example both C and B were assumed to be unknown, and in this case the filter is found to be stable but not asymptotically stable. The filter estimates did not converge to their true values. This is as expected because only the sum of the two parameters multiplying the velocity state is observable.

The non-Riccati equation based techniques developed herein were not tried on this problem because they do not readily handle applications that fall into System Class C.

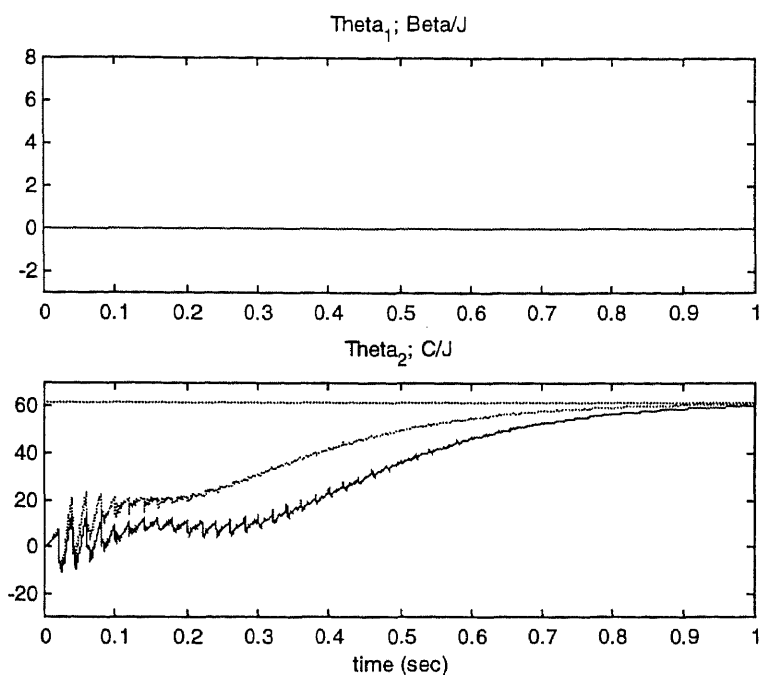

Figure 5.13 Parameter Estimates, Stepper Motor, SDDRE (solid), EKF (dotted), Coulomb Friction Unknown, Viscous Damping Zero

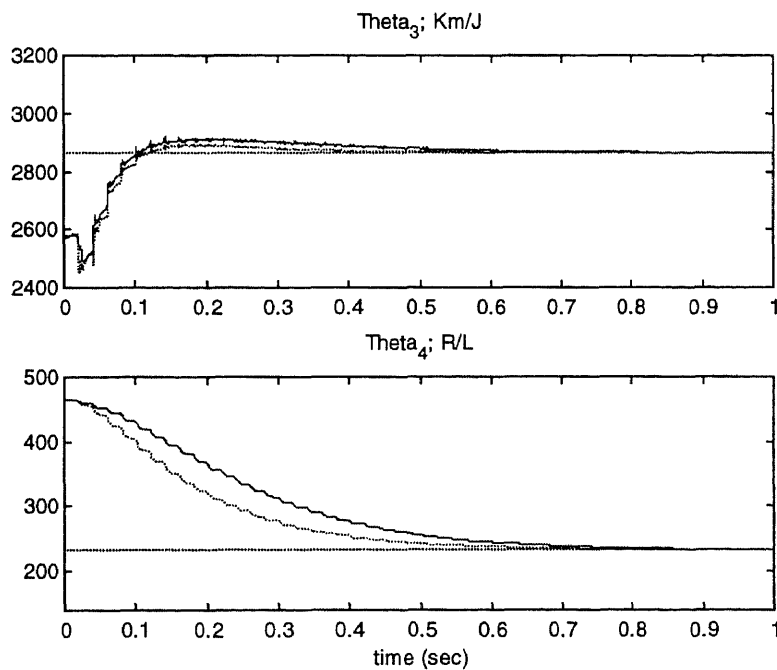

Figure 5.14 Parameter Estimates, Stepper Motor, SDDRE (solid), EKF (dotted), Coulomb Friction Unknown, Viscous Damping Zero

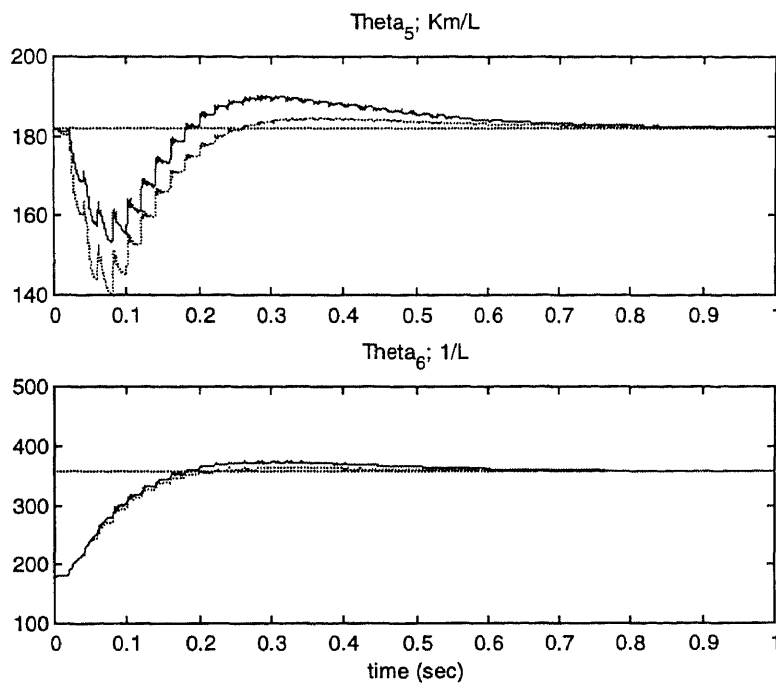

Figure 5.15 Parameter Estimates, Stepper Motor, SDDRE (solid), EKF (dotted), Coulomb Friction Unknown, Viscous Damping Zero

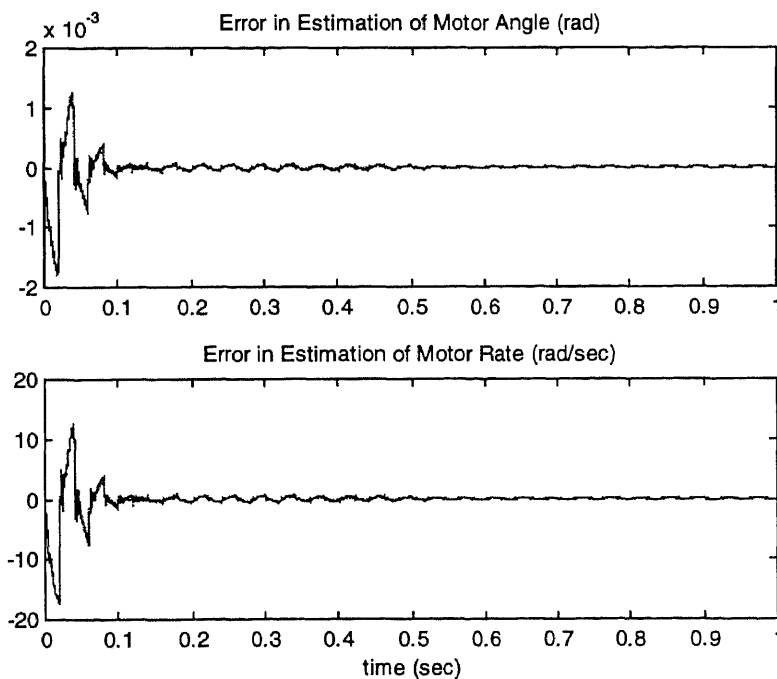

Figure 5.16 State Estimates, Stepper Motor, SDDRE (solid), EKF (dotted), Coulomb Friction Unknown, Viscous Damping Zero

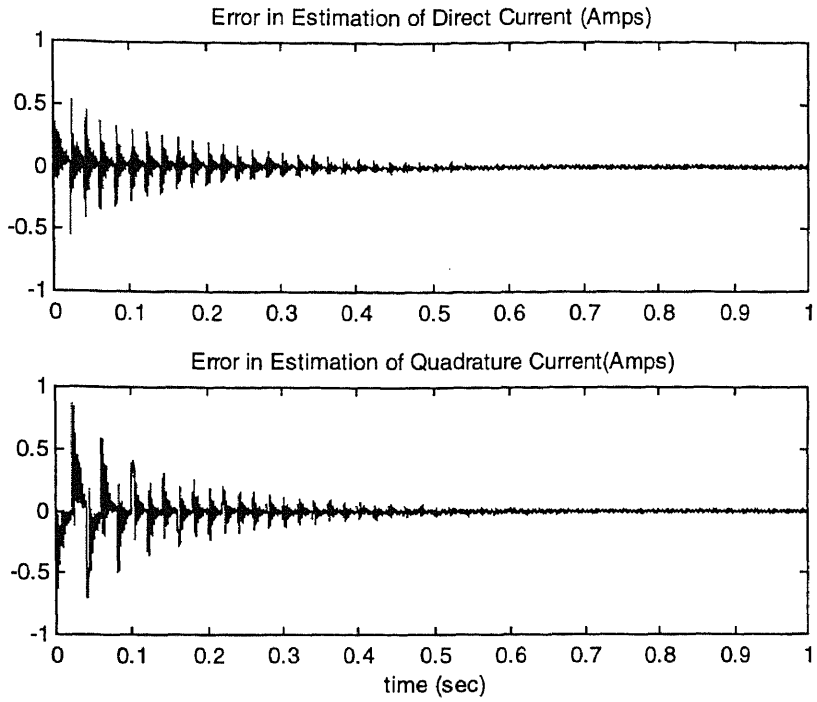

Figure 5.17 State Estimates, Stepper Example Stepper Motor, SDDRE (solid), EKF (dotted), Damping Zero

CHAPTER 6

CONCLUSIONS AND RECOMMENDED FUTURE WORK

Five new methods were developed for the simultaneous, on-line estimation of the unmeasured state variables and unknown parameters in linear and nonlinear dynamic systems of known structure. Two fundamentally distinct groups were defined: those that do not involve Riccati equations, and those that do. Two methods were developed that do not, and both are considered to be extensions of Friedland's parameter observer from full to partial state availability. The first, referred to herein as Nonlinear Observer 1, is a reduced-order variant of Raghavan's adaptive observer. The method is globally stable for systems affine in the unknown parameters and involving nonlinear functions of known quantities. The second, called Nonlinear Observer 2, is a new state and parameter observer obtained by the direct extension of Friedland's parameter observer to the case of partial state availability. It also is globally stable for the same system class noted above, with an added restriction that the A_{12} and A_{22} submatrices be time invariant.

In the category of methods that do involve Riccati equations, three methods were developed: (1) the Separate-bias Reduced-order Kalman filter, (2) the State Dependent Algebraic Riccati Equations (SDARE) filter applied to the joint state and parameter estimation problem, and (3) the State Dependent Differential Riccati Equation (SDDRE) filter, proposed herein as a general filtering method and also applied to this joint estimation problem. The global stability of the Separate-bias Reduced-order Kalman filter is assured for systems affine in the unknown parameters and involving nonlinear function of known quantities. The stability of the SDDRE filter when applied to systems bilinear in the unknown parameters and **estimated** state was examined; however, the

results were inconclusive. The semi-global stability of the Extended Kalman filter for this same system class was proven, given mild assumptions regarding system observability and controllability along estimated trajectories.

Nonlinear Observer 1, created by combining the approach developed by Raghavan with the nonlinear reduced-order filtering ideas developed by Friedland, appears to outperform all others in the simple example provided in Chapter 5. Transients swings were comparatively small, and the step change in one parameter was accurately tracked. In addition, computational demands were moderate. Compared to the Narandra-Annaswamy and Bastion-Gevers observers, it is of comparable order and computational loading, but it provides significantly better tracking of the parameters and states.

Nonlinear Observer 2, created by directly extending Friedland's parameter observation method to the case of partial state availability, was shown to be the least demanding computationally of all methods available, new and previously existing, the order equaling the number of estimated states and parameters. When computational time loading is the primary concern, Nonlinear Observer 2 is clearly the best choice. Its applicability, however, depends on the structure of the system and on the success a user has in finding suitable nonlinear functions, which can be difficult. If this method cannot be applied, the next best choice computationally is Nonlinear Observer 1, which can always be applied successfully to systems that fall into Class B (affine in parameters multiplying nonlinearities depending on known quantities). Finally, if the system is stochastic and optimal performance is desired, and the additional computational burden can be tolerated, the Separate-bias Reduced-order Kalman filter can be applied.

The **Separate-bias Reduced-order Kalman Filter** is the optimal filter in separate-bias form for estimation of the state and biases in linear systems involving measurements that are noise-free. Although applicable to the problem considered herein, the estimation of the state and parameters in deterministic systems, its applicability is somewhat broader in that it can be used to provide an optimal estimate in **stochastic** systems having known process noise statistics.

The predecessor of the present method, the full-order Separate-bias Kalman filter, has over the last 30 years received considerable use due to its inherent numerical stability and efficiency, and because many physical systems naturally take the separate-bias form. Prior to the development of the reduced-order form of the Separate-bias Kalman filter, only the full-order form was available even for applications involving measurements having insignificant levels of noise. In those applications, the computational savings of the reduced-order form can now be realized without loss of the inherent numerical stability and efficiency inherent in the separate-bias structure. Numerical stability, efficiency, and the computational savings of the reduced-order form could be important, for example, in embedded applications involving limited processing capability.

With regard to future work, two recommendations are made. In some applications only part of the measurement vector is noise-free. A useful future result would therefore be the optimal separate-bias filter that applies when part of the measurement vector is noise-free and part contains noise. Also, to make the method more easily applied using digital hardware, the discrete-time form of this same filter could be derived.

When the application involves a system that exceeds the limitations of System Class B and falls into System Class C (bilinear in unknown parameters and estimated states),

two methods can apply, an existing method called the **SDARE Filter** and a new method called the **SDDRE Filter**. Both are general filtering algorithms applicable to general nonlinear system estimation problems, the difference being that the SDARE filter uses a frozen, algebraic Riccati equation and the SDDRE uses a complete Riccati equation, including the time derivative term. Both were applied herein to the state and estimation problem.

The SDARE filter was found to work quite well in several examples of lower order (i.e. two unknown parameters and two states). However, as the number of parameters increases beyond two, the method becomes difficult to apply due to an apparent lack of “observability” within the filter. It becomes necessary to distinguish each new parameter from the previous by altering their dynamics as seen by the filter, so that they become observable in the linear sense, such that the algebraic Riccati equation has a solution. This is a suitable approach for a few parameters, but as the number grows, numerical difficulties tend to result.

The observability problems of the SDARE filter prompted the development of the SDDRE filter. By using a complete Riccati equation, the need for “linear” observability is eliminated. It is replaced by the requirement that the system be observable over a time interval rather than at every instant, which is a much easier condition to achieve. The SDDRE is therefore recommended over the SDARE filter, because it avoids these potential “linear” observability problems that preclude filter operation even when the system is observable. In addition, it is recommended because the computational demands associated with the generation of the Riccati solution are greatly reduced. It is

much easier to propagate one step forward in time the solution to a set of differential equations than it is to solve a similarly dimensioned algebraic Riccati equation.

The new SDDRE filter was shown to be similar to the Extended Kalman Filter in structure, particularly for systems bilinear in the state and parameters. An assessment of the stability of both filters was performed using Lyapunov theory. A semi-global (finite) region of stability has been shown to exist for the EKF applied to bilinear systems. The system states and parameters must be observable. The observability of the system along the true state trajectory and with the true parameters, is assumed to affirm of the observability of the system along the estimated state and parameter trajectory.

Ljung examined the stability of the EKF when used as a parameter estimator in linear systems and found no guarantee of convergence under any condition. The results of this present work indicate that when used as a parameter estimator in a linear system, the EKF will produce convergent state and parameter estimates providing that the augmented system is controllable and observable along true trajectories, and the initial parameter estimation errors are small.

Both the new SDDRE filter and the EKF were simulation tested on a 4th order stepper motor with 5 unknown parameters. The new filter was found to provide similar and potentially better transient performance than the EKF, which is somewhat surprising when noting that the theory developed herein indicates that the EKF is stable, and is inconclusive with regard to the SDDRE filter. Perhaps the new SDDRE filter can be shown in future studies to have similar or superior stability characteristics over the EKF, as the simulation results suggest. The stability of the SDDRE filter when applied to bilinear systems is an area of potentially fruitful future investigation.

REFERENCES

- [1] A.T. Alouani, P.Xia, T.R.Rice, and W.D.Blair, "On the optimality of two-stage state estimation in the presence of random bias," *IEEE Trans. Automat. Contr.*, vol. AC-38, no. 8, Aug. 1993.
- [2] K.J. Åström and B. Wittenmark, *Adaptive Control*, 2nd Edition, Reading, MA, Addison-Wesley, 1995.
- [3] G. Bastin and M.R.Gevers, "Stable adaptive observers for nonlinear time-varying systems", *IEEE Trans. Automat. Contr.*, vol. 33, no. 7, pp. 650-658, July 1998.
- [4] A.J. Blauch, M. Bodson and J. Chasson, "High-Speed Parameter Estimation of Stepper Motors", *IEEE Trans. Contr. Sys. Tech.*, vol. 1, no. 4, December 1993.
- [5] M.Bodson, J.N. Chiasson, R.T. Novotnak and R.B.Rekowski, "High-Performance Nonlinear Feedback Control of a Permanent Magnet Stepper Motor", *IEEE Trans. Contr. Sys. Tech.*, vol. 1, no. 1, March 1993.
- [6] A. K. Caglayan and R.E. Lancraft, "A separated-bias identification and state estimation algorithm for nonlinear systems," *Automatica*, vol. 19, no. 5, pp. 561-570, 1983.
- [7] Y.M.Cho and R.Rajamani, "A Systematic Approach to Adaptive Observer Synthesis for Nonlinear Systems ", *IEEE Trans. Automat. Contr.*, vol. 42, no. 4, pp. 534-537, April 1997.
- [8] J.R. Cloutier, D.N.D'Souza and C.P.Mracek, "Nonlinear regulation and nonlinear H-infinity control via the state-dependent Riccati equation technique: part 1, theory," *Proc 1st International Conf. on Nonlinear Problems in Aviation and Aerospace*, Daytona Beach, FL, May 1996.
- [9] J.R. Cloutier, D.N.D'Souza and C.P.Mracek, "Nonlinear regulation and nonlinear H-infinity control via the state-dependent Riccati equation technique: part 2, examples," *Proc 1st International Conf. on Nonlinear Problems in Aviation and Aerospace*, Daytona Beach, FL, May 1996.
- [10] D.G. DeWolf, D.M.Wilberg, "An ordinary differential equation technique for continuous-time parameter estimation," *IEEE Trans. Automat. Contr.*, vol. 38, pp. 514-528,1993.

- [11] B. Friedland, "Treatment of bias in recursive filtering," *IEEE Trans. Automat. Contr.*, vol. AC-14, pp. 359-367, Aug. 1969.
- [12] B. Friedland, "Observers", *The Controls Handbook*, Boca Raton, FL, CRC Press, 1996.
- [13] B. Friedland, "On solutions of the Riccati equation in optimization problems," *IEEE Trans. Automat. Contr.*, vol. AC-12, pp. 303-304, June 1967.
- [14] B. Friedland, "On the Calibration Problem", *IEEE Trans. Automat. Contr.*, vol. AC-22, no. 6, pp. 899-905, December 1977.
- [15] B. Friedland, "On the properties of reduced-order Kalman filters," *IEEE Trans. Automat. Contr.*, vol. AC-34, no. 3, Mar. 1989.
- [16] B. Friedland, *Control System Design, An Introduction to State Space Methods*, New York, NY, McGraw-Hill Book Co., 1986.
- [17] B. Friedland, "A nonlinear observer for estimating parameters in dynamic systems," *Automatica*, vol. 33, no. 8, pp. 1525-1530, August 1997.
- [18] D.A. Haessig, "A Method of State and Parameter Estimation in Nonlinear Systems," *Proc. Amer. Contr. Conf.*, Albuquerque, NM, June 1997, pp. 947-951.
- [19] D.A. Haessig, "Separate-Bias Estimation with Reduced-Order Kalman Filters," *IEEE Trans. Automat. Contr.*, vol. 43, no. 7, July 1998, pp. 983-986.
- [20] C.S. Hsieh and F.C.Chen, "Optimal solution of the two-stage Kalman estimator," *Proc. 34th CDC*, New Orleans, LA, Dec. 1995.
- [21] M.B. Ignagni, "An alternate derivation and extension of Friedland's two-stage Kalman estimator," *IEEE Trans. Automat. Contr.*, vol. AC-26, no. 3, pp. 746-750 June 1981.
- [22] M.B. Ignagni, "Separate-bias Kalman estimator with bias state noise," *IEEE Trans. Automat. Contr.*, vol. AC-35, no. 3, pp. 338-341, Mar. 1990.
- [23] A.M. Liapunov, *Problème General de la Stabilité du Mouvement*, Princeton, NJ, Princeton University Press, 1947. (Reprint of Russian monograph of 1892.)

- [24] A. Isidori, *Nonlinear Control Systems*, 3rd ed., London, Springer –Verlag, 1995.
- [25] L. Ljung, “Asymptotic behavior of the extended Kalman filter as a parameter estimator for linear systems,” *IEEE Trans. Automat. Contr.*, vol. AC-24, pp. 36-50, 1979.
- [26] J.F. Magni , “On Continuous-Time Parameter Identification by Using Observers,” *IEEE Trans. Automat. Cntrl.*, Oct. 1995.
- [27] R.E. Maine, K.W. Iliff, “Identification of dynamic systems,” NASA publication, 1985.
- [28] J.M.Mendel and B.D Washburn, “Multistage estimation of bias states in linear systems”, *Int. J. Contrl*, vol. 28, no. 1, pp. 511-524, 1978.
- [29] J.M. Mendel, “Extension of Friedland’s bias filtering technique to a class of nonlinear systems,” *IEEE Trans. Automat. Contr.*, vol AC-21, pp. 296, 1976.
- [30] E.A. Misawa, and J.K Hendrik, “Nonlinear Observers, A State of the Art Survey,” *ASME Jour. Dyn. Sys. Meas. Cntr.*, vol. 11, pp. 344-352.
- [31] A. P. Morgan and K.S. Narendra, “On the Asymptotic Stability of Certain Linear Non-autonomous Differential Equations,” *SIAM J. Control and Optimization*, vol 15, no. 1, January 1977.
- [32] C.P. Mracek, J.R.Cloutier, C.A.D’Souza, “A new technique for nonlinear estimation,” *American Contr. Conf.*, Seattle, WA, June 1995.
- [33] K.S. Narendra and P. Kudva , “Stable adaptive schemes for system identification and control – Part I & II,” *IEEE Trans. on Systems, Man, and Cybernetics*, vol. SMC-4, pp. 542-560, Nov. 1974.
- [34] K.S. Narendra and A.M Annaswamy, *Stable Adaptive Systems*, Englewood Cliffs, NJ, Prentice Hall, 1989.
- [35] V. Pappano, B. Friedland, “Speed Sensorless Observer for an Induction Machine with Separate Bias Estimation,” *Proc. American Control Conference*, Albuquerque, NM, June 1997, pp.3805--3806.
- [36] S. Raghavan, “Observers and Compensators for Nonlinear Systems, With Application to Flexible-Joint Robots,” Ph.D. Dissertation, Department of Mechanical Engineering, U. of C., Berkeley, 1992.

- [37] M. Ricardo, "Adaptive Observers for Single Output Nonlinear Systems," *IEEE Trans. Automat. Contr.*, vol. 35, no. 9, pp. 1054-1058, Sept. 1990.
- [38] I. Rusnak, et.al., "Necessary and Sufficient Conditions on the Observability and Identifiability of Linear Systems", *Proc. Amer. Contr. Conf.*, Chicago, IL, June 24-26, 1992.
- [39] I. Rusnak, et.al., "Optimal State Estimation and Parameters Identification of MIMO uncertain Stochastic Linear Systems", *Proc. Int. Conf. Sys. Man, Cybernetics*, Vancouver, Canada, October 22-25, 1995.
- [40] I. Rusnak, et.al., "Simultaneous State Observability and Parameters Identifiability of discrete Stochastic Linear Systems", *Proc. Amer. Contr. Conf.*, San Francisco, CA, June 2-4, 1993.
- [41] S. Sastry, J. Bodson, *Adaptive Control: Stability, Convergence, and Robustness*, Englewood Cliffs, NJ, Prentice Hall, 1989.
- [42] H. Unbehauen, G.P.Rao, "Continuous-time approaches to system identification – A survey," *Automatica*, vol. 26, no. 1, pp. 23-25, 1990.
- [43] M. Vidyasagar, *Nonlinear Systems Analysis*, Englewood Cliffs, NJ, Prentice Hall, 1993.
- [44] Y. Yu, J.R.Boston, M. Simaan and J. Antiki, "Estimation of Systemic Vascular Bed Parameters for Artificial Heart Control", *IEEE Trans. Automat. Contr.*, vol. 43, no. 6, pp. 765-778, June 1998.