



On the need to consider wood formation processes in global vegetation models and a suggested approach

Andrew D. Friend¹ · Annemarie H. Eckes-Shephard¹ · Patrick Fonti² · Tim T. Rademacher^{3,4,5} · Cyrille B. K. Rathgeber⁶ · Andrew D. Richardson^{3,4} · Rachael H. Turton^{7,8}

Received: 21 February 2019 / Accepted: 7 March 2019 / Published online: 30 April 2019
© The Author(s) 2019

Abstract

• **Key message** Dynamic global vegetation models are key tools for interpreting and forecasting the responses of terrestrial ecosystems to climatic variation and other drivers. They estimate plant growth as the outcome of the supply of carbon through photosynthesis. However, growth is itself under direct control, and not simply controlled by the amount of available carbon. Therefore predictions by current photosynthesis-driven models of large increases in future vegetation biomass due to increasing concentrations of atmospheric CO₂ may be significant over-estimations. We describe how current understanding of wood formation can be used to reformulate global vegetation models, with potentially major implications for their behaviour.

Keywords Dynamic global vegetation model · Xylogenesis · Carbon · Source · Sink

1 Global vegetation models: from a source-dominated to a balanced source-sink approach

The last couple of decades have seen the emergence of so-called earth system models (ESMs) for forecasting global climate responses to emissions of anthropogenic greenhouse gases (Hajima et al. 2014). ESMs are built around a general circulation model of the atmosphere, coupled to representations of ocean and land components, including the exchanges of carbon between these different reservoirs. Land surface carbon exchange with the atmosphere and structural dynamics are simulated using a sub-model of vegetation and soil processes, usually described as a

“dynamic global vegetation model” (DGVM). These sub-models are dynamic in the sense that they simulate changes in vegetation distribution and structure over time from underlying physiological and ecological principles (e.g., Friend and White 2000; Sitch et al. 2003), as opposed to a static Global Vegetation Model in which vegetation distribution (and sometimes structure) is prescribed, for example, from remote sensing of the land surface (e.g., Sellers et al. 1996; Wang et al. 2010).

DGVMs have been used extensively for the simulation of historical and future land-atmosphere carbon fluxes in order to attribute (e.g., Keenan and Williams 2018; Le Quéré et al. 2018) and predict (e.g., Cramer et al. 2001; Friend et al. 2014) terrestrial biosphere responses to, primarily, climate, CO₂, and land use changes. A common feature of these simulations is that while historical dynamics are largely consistent with atmospheric CO₂ constraints (e.g., Le Quéré et al. 2018), future predictions diverge quite markedly (e.g., Arora et al. 2013; Jones et al. 2013; Friedlingstein et al. 2014), with differences in the responses of vegetation carbon fluxes playing a major role. Moreover, this uncertainty has remained “stubbornly consistent” (Quetin and Swann 2018), despite major efforts to expand the biological and physical process representations in these models (Lovenduski and Bonan 2017). DGVMs largely attribute the historical net carbon sink on land to the CO₂ fertilisation of plant growth through

Handling Editor: Erwin Dreyer

Contribution of the co-authors ADF and CBKR conceived of the paper, ADF led the writing and all co-authors contributed text and/or suggestions; RHT drew the figures with input from all other authors.

This article is part of the Topical Collection on *Wood formation and tree adaptation to climate*

✉ Andrew D. Friend
adf10@cam.ac.uk

Extended author information available on the last page of the article.

enhanced photosynthesis, and most predict this effect to become stronger in coming decades, resulting in a large terrestrial carbon sink, especially in forests, but with substantial variation between models (e.g., Friend et al. 2014).

An overview of how carbon fluxes are represented in current DGVMs is shown in Fig. 1a. It is evident from the relationships in this structure that variability in the input of carbon (“Atmospheric CO₂”) through photosynthesis (“GPP”) has a dominant influence on overall dynamics, especially of the plant and soil carbon reservoirs. Furthermore, plant growth (“NPP”) is determined directly from the difference between photosynthesis and plant respiration, with no explicit representation of growth processes themselves. This implicit approach to growth has not been perceived as a problem for a variety of reasons, the main one being the belief that plant productivity is only, or mainly, limited by the input of carbon through photosynthesis, i.e., growth is C source-limited (e.g., eqn 3 of Lloyd and Farquhar 1996). However, evidence that growth processes have greater environmental sensitivities than photosynthesis, and even control photosynthesis under many conditions through internal feedback, has led to calls for a re-evaluation of this C source-driven production paradigm, and for it to be replaced with one in which the demand (i.e., “sink”) for carbon plays at least as important a role as its supply (e.g., Millard et al. 2007; Fatichi et al. 2014 Körner 2015; Fatichi et al. 2019; Zuidema et al. 2018). These arguments are supported by the failure of the large stimulation of photosynthesis by elevated CO₂ in experimental manipulations to be translated into equivalent growth responses (e.g., Kirschbaum 2011; Woodward 2002; Dawes et al. 2015; Ellsworth et al. 2017), and evidence that direct environmental constraints on growth, such as drought and low temperatures, may be stronger than those on photosynthesis (e.g., Hsiao 1973; Parent et al. 2010; Muller et al. 2011). Indeed, observations of non-structural carbohydrate (NSC) accumulation under stress (Hoch 2015; Hartmann et al. 2018), and feedback inhibition of photosynthesis when growth is limited (e.g., Paul and Foyer 2001), indicate the potential for sink strength to limit overall carbon assimilation into durable biomass. We therefore suggest that the arguments for an important role for sink processes are persuasive enough that it would be worthwhile to incorporate them into a DGVM framework in order to explore their implications for ecosystem carbon fluxes and community dynamics.

Attempts to incorporate sink-limited growth into DGVMs have so far been limited (Fatichi et al. 2019), probably because of the lack of a perceived need and/or clear approach to how it might be achieved, particularly within current model structures. Nevertheless, some efforts have been undertaken, such as modifications to existing allocation routines (e.g., Guillemot et al. 2017), or highly

empirical approaches (e.g., Leuzinger et al. 2013). In the latter, for example, an empirical model of the temperature impact on annual NPP was implemented based on growing-degree days within the Lund-Potsdam-Jena (LPJ) DGVM (Sitch et al. 2003). It was found that the addition of this constraint greatly reduced predicted biomass under low-temperature limited situations, especially at high latitudes and altitudes, compared to when only photosynthesis limits growth. Other relevant developments include the incorporation of nutrient cycling in DGVMs, with the potential to constrain sink strength. For example, the HYBRID4.1 (Friend and White 2000) and O-CN models (Zaehle and Friend 2010) simulate the dynamics of a labile plant N pool, which then constrains tissue growth through stoichiometric limits (Friend et al. 1997). Therefore, available N has the potential to limit growth, with major impacts on predicted responses to increasing atmospheric CO₂ (Cramer et al. 2001; Zaehle et al. 2010). However, these developments do not explicitly consider growth processes, with growth still the outcome of carbon balance.

While not DGVMs, Functional-Structural Plant Models treat sink activity explicitly. The L-PEACH model of Allen et al. (2005), for example, includes a number of features directly relevant to modelling source-sink dynamics. Photosynthesis is inhibited by the accumulation of carbohydrate in the leaf due to inadequate sink strength, the flow of carbohydrates around the plant is based on concentration gradients across resistances (Thornley 1972), storage compartments are included as sinks and sources, and the uptake of carbohydrates by sinks is a function of the local sugar concentration in the phloem and the degree of water stress. However, these models focus on the simulation of plant form (e.g., branching structure), and have not been used to address the significance of sink-limited growth *per se*, as far as we know, and their detailed consideration of small stem segments makes them unsuitable for global modelling. We therefore conclude that there is a need for a new process-based methodology simulating plant growth within DGVMs, with a core element being the explicit treatment of sink processes and their controls.

2 A way forward: xylogenesis

The need to better understand climate-growth relationships in dendroecology has led to the development of xylogenesis models. As these explicitly consider wood growth, they are promising frameworks for incorporating sink activity in DGVMs. Perhaps the best known is the Vaganov-Shashkin (VS) simulation model (Vaganov et al. 2006), which aims to go beyond previous statistical frameworks (e.g., Fritts et al. 1971) in providing a mechanistic tool for addressing questions such as details of climatic controls on the

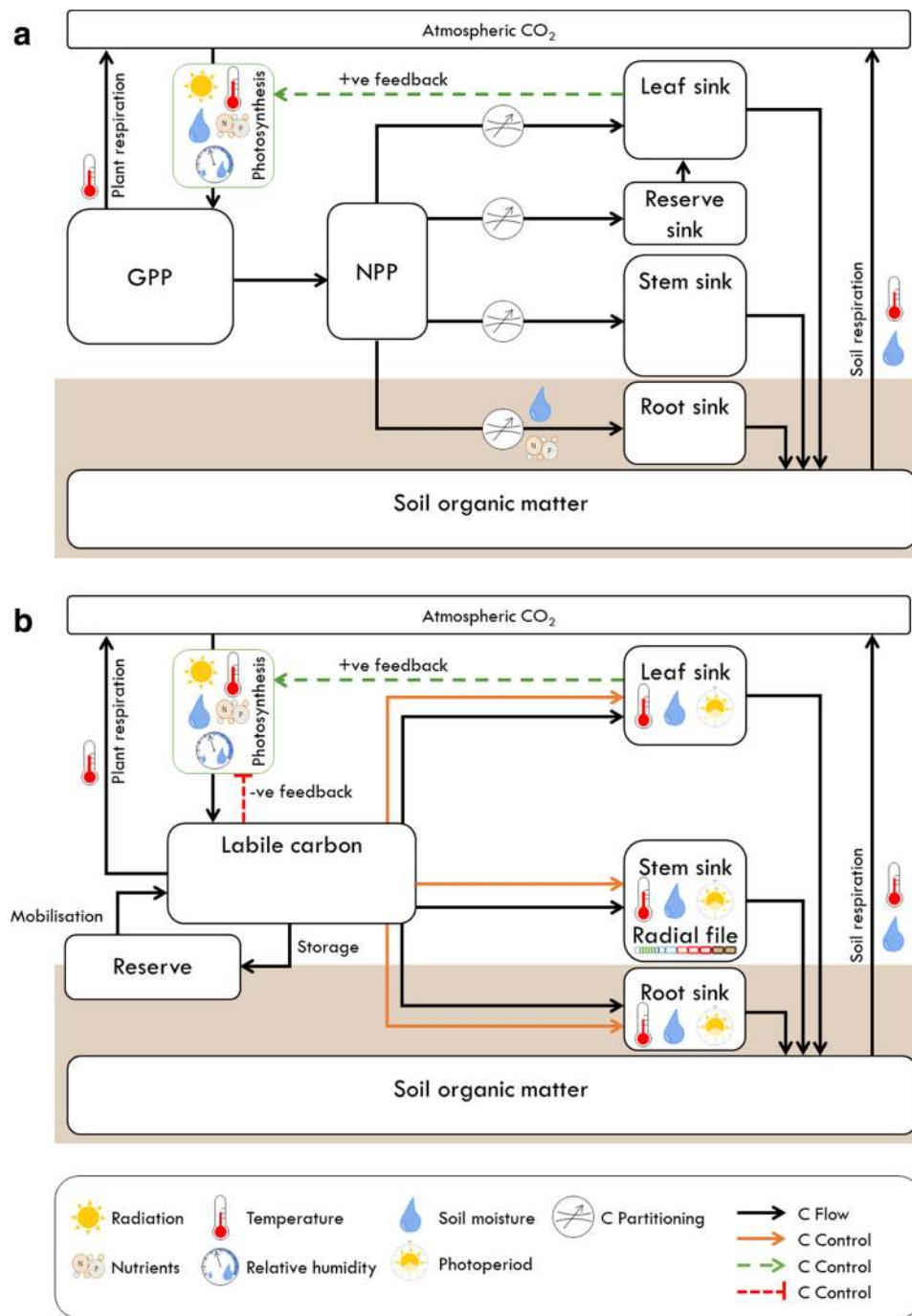

Fig. 1 **a** Schematic representation of carbon flows and controls in a generic DGVM. Photosynthesis is under strong environmental control, resulting in gross uptake of carbon (GPP, gross primary productivity), from which respiration is subtracted to give net primary productivity (NPP). This NPP is then partitioned to various sinks, with relative proportions determined by allometric coefficients (e.g., fixed or based on goal-seeking/optimisation assumptions), or based on passive filling in the case of a reserve pool. Here, we indicate that the prime purpose of the reserve pool is to replenish the foliage following complete leaf loss such as during winter in a cold deciduous tree, as for example, in the ORCHIDEE model (Krinner et al. 2005). Turnover of structural sinks is incorporated into soil organic matter, which decays back to atmospheric CO₂. The positive feedback from the leaf sink

to photosynthesis is due to the dependency of radiation interception on leaf area. **b** Schematic representation of a proposed growth- and source/sink feedback-enabled DGVM. A labile carbon pool of sugars receives carbon from photosynthesis and, potentially, storage reserves, and loses it to respiration and flows to various sinks. The sink strengths are explicitly modelled, and therefore the flows to them (and their growth) are the outcomes of their activities, rather than the rate of photosynthesis. The activities of the sinks are under their own environmental and internal controls, including signalling effects from the size of the labile pool itself (orange arrows). The labile pool also affects photosynthetic capacity through negative feedback. The dynamics of the labile pool thereby ensure coordination between growth and photosynthesis

formation of conifer tree rings in dry, cold, and temperate regions. The dynamics of cambial cell production, and subsequent cell enlargement, wall thickening, and eventual death of xylem cells are treated, with dependencies on temperature and soil water content. Xylogenesis models such as these point the way to how sink activity in trees can be modelled as they explicitly consider the dynamics of volume and mass increases at the cellular level, and how they are driven by environmental factors. However, the VS model is not mechanistically tied to the whole tree, and so does not provide a complete framework for inclusion of growth in a DGVM. Moreover, these models have not yet been validated at the scale of the processes they are representing, for example using wood formation monitoring data.

Fatichi et al. (2014) recommended a series of processes that should be implemented in DGVMs in order for them to realistically simulate growth, or at least “C allocation”. However, their list includes components that would be very challenging to implement efficiently in a global model. Moreover, they do not explicitly discuss wood growth, whereas this is the process whereby the majority of carbon is sequestered into long-lived plant material, and so needs to be central to any DGVM representation of growth processes.

Here, we outline a possible approach for building a balanced source-sink treatment of growth in DGVMs, based on a representation of xylogenesis, scaled to the whole tree in terms of total carbon balance, with links to tree size and shape. While we focus on the process of wood formation as this represents the dominant carbon sink on land, much of the approach is relevant to all higher plant life forms.

We do not advocate a completely sink- or source-driven approach, but one in which these two controls are coupled. Plants grow as integrated wholes, and must achieve a balance between carbon uptake, storage, and growth (Smith and Stitt 2007). A model of coupled source- and sink-controls on tree growth therefore needs to include both an explicit treatment of wood formation and a link between growth and photosynthesis. Storage pools are required to buffer supply and demand on different timescales, and growth processes need to be simulated on a sufficiently short time-step to allow for the influence of climatic variability. The whole-plant carbon balance also requires treatments of respiration and non-wood sinks such as reproduction. A proposal for such a scheme is presented in Fig. 1b. Whether this scheme is applied at the individual or stand scale will depend on the overall structure of the model, but an individual-scale implementation allows resolution of those features that are size- (e.g., Bennett et al. 2015), age- (e.g., Hayat et al. 2017), and shape-dependent. As a tree grows, the relative proportions of its different components can change, affecting the mass, volume, and area ratios between source and sink tissues, with important consequences for controls on wood formation and growth (Stephenson et al.

2014; Hayat et al. 2017; Hartmann et al. 2018), making an individual-based approach desirable. Such an approach also allows for the treatment of successional dynamics and competition (e.g., Friend et al. 1997).

Two key features of this scheme will require innovations that go beyond current dynamic global vegetation models: (1) explicit wood formation and (2) associated dependencies and feedback between sink- and source-activities in order to achieve coordinated uptake and growth. Below, we outline a possible approach to achieve this, discuss how such changes might alter model behaviour, and suggest how future research might fill critical remaining knowledge gaps.

3 Developing an explicit wood growth model for incorporation into DGVMs

A mechanistic approach to the incorporation of explicit internal carbon sink processes into a DGVM will need to treat the influences of environmental factors, such as temperature and the supply of water and nutrients, on xylem formation. Carbon supply through photosynthesis and/or from reserves will also affect xylem formation, either directly as a substrate for growth and associated energetic requirements, and/or, as evidence suggests, indirectly as a signal metabolite (Smith and Stitt 2007).

As mentioned, wood formation consists of the differentiation of secondary xylem and associated cell developmental phases, often described as “xylogenesis”, during which xylem precursors divide, enlarge, undergo secondary wall thickening, and finally succumb to programmed cell death (see Fig. 2). Modelling this process mechanistically is challenging due to complex interactions between environmental conditions and internal signalling pathways linked to physiological and developmental factors. Moreover, periods of volume growth and mass increment occur at different times and in different cell developmental phases (Cuny et al. 2015). Despite this complexity, we believe that there is now sufficient knowledge concerning the basic processes of xylem differentiation and how they respond to environmental and developmental factors, at least in conifers (Rathgeber et al. 2016), to build a model suitable for testing hypotheses and as a basis for a treatment of whole-tree growth for insertion into a DGVM.

During the growing season, the vascular cambium produces, at most, one new xylem cell per radial file per day, which then takes 1–2 months to mature (Rathgeber et al. 2016). This suggests that a suitable approach would be to simulate division and differentiation of the cells in a radial file on a daily time-step. Each cell would be classed as either cambial (i.e., an initial or mother xylem cell still capable of division), enlarging (i.e., a primary cell-walled differentiating xylem cell no longer capable

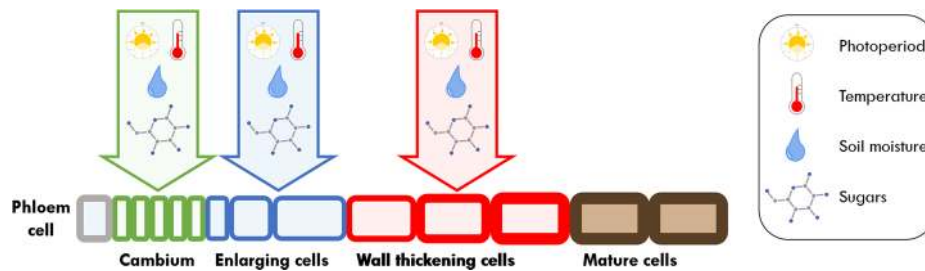

Fig. 2 A radial file of developing tracheids, including dividing cells in the cambium, and enlarging, wall thickening, and mature cells in the forming xylem. By including each developmental phase, the model can

be compared in detail with observations. External and internal factors are assumed to act directly on the differentiating cells, influencing the rates and/or the duration of cell differentiation

of division), wall thickening (i.e., a secondary-cell-walled maturing xylem cell), or mature (i.e., a dead but fully functional xylem cell). Transitions between these cell developmental phases can be computed on a daily basis, as can be the amount of enlargement and cell wall deposition for the appropriate cell developmental phases. Xylogenesis consumes carbon through respiration and the deposition of wall materials, thus providing a major sink for internal carbohydrates. Xylogenesis not only determines the amount of carbon sequestered, but also shapes the morphology (i.e., lumen size and wall thickness) of the xylem cells. This morphology in turn determines the tree's water transport capacity (which limits foliage area and stomatal conductance) and safety (which can determine mortality), and also its mechanical properties (which affect height growth and branching pattern).

While the sequence of secondary xylem differentiation in conifers is well-known, details of the controls on the rates and timings of division, enlargement, cell wall thickening, and eventual death are not yet fully understood (Hartmann et al. 2017). Factors believed to be important for rates include cambial temperature, xylem cell turgor, and internal signals (e.g., auxins, peptide ligands, sucrose). Durations within cell development phases are related to cell age, cell size, and internal signals (both positional and related to season and environmental conditions). External signals such as wind speed can also affect tree growth; while the mechanisms are not well understood and have not been incorporated into growth models of the type discussed here, recent work suggests an approach for doing so in relation to both primary and secondary growth (Mouliat et al. 2015).

Despite our lack of knowledge concerning many of these controls, understanding has recently greatly benefited from measurements of the seasonal dynamics of wood formation using microcores, extracted at weekly intervals during the growing season (e.g., Cuny et al. 2014, 2019; Balducci et al. 2016; Cuny and Rathgeber 2016). To date, these measurements have mainly been made on conifers with their relatively simple wood anatomy. Our modelling approach is therefore initially focused on these species. However, we

aim to model angiosperm species as well, and indeed extend our approach to non-woody plants.

A dynamic model of cellular differentiation along a single radial file can be separated into two conceptual components. The first is a spatially explicit representation of a linear radial file of cells with particular identities, which determine their potentials for division, enlargement, thickening, and death, and the sequential dynamic transitions between those identities. This component is an unchangeable computational framework as it mirrors how xylogenesis actually occurs (although increased complexity will be necessary to treat woody angiosperm anatomies). The second component is a representation of the controls on these rates and transitions (including onset and cessation), which are in many cases uncertain and must therefore be included as hypotheses to be tested through consistency with observations.

4 Key data sources

Two important types of observational data are available with which to test hypotheses and determine parameter values, kinetic and anatomical. The recent development of a tracheid differentiation kinetics approach is providing data and results that can be directly used to test mechanistic wood formation model hypotheses and calibrate parameter values (Cuny et al. 2013). These kinetic data quantify the temporal course of cellular dynamics, such as the number of cells per developmental zone (e.g., the cell enlargement zone), the characteristics of those cells (e.g., size and cell wall thicknesses), and the timings of their transitions (e.g., the beginning and end dates for cells in a given phase during the growing season). This approach is based on the statistical analysis of wood formation monitoring data, and is associated with quantitative wood anatomy data. Wood formation monitoring data consist of weekly counts of cell number in the four differentiation zones (i.e., cambium, enlarging, wall thickening, and mature). From these data, the duration spent by each forming cell in each

differentiation zone can be estimated (Wodzicki 1971; Rossi et al. 2006; Cuny et al. 2013).

In contrast, quantitative anatomical data concern the cells within the tree ring at the end of the growing season, and provide measurements of tracheid dimensions (e.g., cell wall thicknesses and lumen diameters). Knowing the time a cell spent in each differentiation stage from kinetic data, and the result in terms of morphology from end-of-season anatomy, it is possible to compute the rate of change for the different processes (see Fig. S2 of Cuny et al. (2019) for a graphical explanation). For example, an earlywood cell that spent 15 days in enlargement for a final cell lumen diameter of 30 μm , enlarged at a rate of 2 $\mu\text{m}/\text{day}$. The rates of the cell differentiation processes, and the cell differentiation phase durations, will both be represented in the mechanistic wood formation model and so can be used for its parameterisation as well as its validation.

We also suggest that once a basic model has been developed using tracheid differentiation kinetics data, the model could be tested and further developed at larger temporal and spatial scales using new data sets from quantitative wood anatomy which are being produced (e.g., Castagneri et al. 2017; Ziaco et al. 2016). Tree-ring microdensitometric profiles are an additional source of data for the relationship between wood anatomy and wood density (Cuny et al. 2014).

Finally, while wood formation studies to date span a relatively limited amount of time (e.g., up to 13 years in Rossi et al. 2016; up to 7 years in Cuny et al. 2019), anatomical data can be obtained after wood formation has ceased and so can be extended over many years, or even centuries, into the past. This increases the range of responses to environmental conditions that can be analysed, including to climatic variability, CO_2 concentration, and successional stage. For example, an 87-y cellular anatomy dataset was used to study climatic controls on tracheid development in *Picea abies* along an altitudinal gradient (Castagneri et al. 2017), and Fonti et al. (2013) investigated the relationship between temperature and tracheid anatomy using a 312-y tree-ring chronology from a southern Siberian larch forest. These types data are potentially very useful additional sources of information for the xylogenesis model envisaged here, and, moreover, the model could be used to interpret these data types mechanistically.

5 Scaling to the whole tree

While it is relatively easy to code controls due to fundamental environmental factors such as temperature and soil water (e.g., through the rate of cell cycling for temperature and rate of cell expansion for local turgor), a representation of signalling pathways is harder to devise. A

sensible approach is therefore to implement these as simply as possible, such that they are adequate to explain first-order observed responses, for example using simple spatial gradients in growth substances (e.g., Hartmann et al. 2017). A key dependency that needs to be represented is the effect of the concentration of carbohydrate substrate: is this to be treated only as a substrate pool for cell wall thickening (e.g., with Michaelis-Menten kinetics), or does it also, or mainly, affect wood growth through a signalling pathway which controls sink activity (e.g., cambial division)?

Smith and Stitt (2007) provide evidence that growth is directly regulated by carbohydrate supply in order to avoid carbon starvation. This is achieved through an effect of carbon availability on the synthesis of proteins responsible for growth processes, controlling both cell proliferation (through controls on the cell cycle) and cell wall synthesis. This suggests that a model of xylogenesis should include direct regulation of growth activity by carbon supply (and potentially by other growth regulators such as phytohormones) as a signalling pathway, thus providing a mechanism for coordination between supply and demand, rather than regulation only through a substrate-limited growth response. As Smith and Stitt (2007) suggest, this is consistent with a regulatory framework in which resources are conserved when carbon availability is limited. They provide evidence for rapid “acute” and acclimatory regulatory responses. Interestingly, genes involved in the cell cycle have transcript levels that decrease during the night, suggesting that diurnal cycles in growth, and potentially phenological responses on seasonal timescales, provide additional constraints that need to be considered. The extent to which these processes occur in trees is yet to be determined, but studies such as Etchells et al. (2015) indicate a strong regulatory control of wood growth.

The regulation of C source activity (i.e., photosynthetic rate) by sink demand in plants is well-known (Paul and Foyer 2001), although the exact mechanism is unclear (Yan et al. 2013). There is good evidence for its occurrence in trees (e.g., Iglesias et al. 2002), and appears to be mediated by the accumulation of phloem sugars at the source sites in leaves (Franck et al. 2006; Ainsworth and Bush 2011). Ainsworth and Bush (2011) describe how phloem loading plays a key role in balancing carbon source activity with sink utilisation in apoplastic loaders; loading can increase sugar concentrations against a gradient of 2 or 3 orders of magnitude. An increase in mesophyll sugar levels when sink strength is reduced in active loaders must therefore be the result of downregulation of phloem loaders in response to accumulation of phloem sugars, rather than as a purely physical effect. The resulting increases in mesophyll sugars can cause reductions in photosynthetic capacity (e.g., Krapp and Stitt 1995; Paul and Foyer 2001). A model approach can therefore be envisaged, applicable to both active and passive

loaders, in which photosynthetic capacity is regulated in response to the concentrations of labile sugars, whether at the tissue or whole-plant level.

Taken together, there exists therefore a good theoretical basis for the development of a whole-plant regulatory framework linking sources and sinks mediated by the concentrations of labile sugars, with sinks being driven by the production and differentiation of meristematic cells and sources by leaf photosynthesis.

As well as treating the activities of sink and source processes and the feedback between them, a model of whole-tree growth needs to scale the growth dynamics of the radial file, photosynthesis, and internal carbohydrate dynamics to the whole tree. This can be achieved by treating both the overall structure of the tree (canopy height, stem diameter, rooting depth, leaf area, crown area, etc.), as well as the internal dynamics of carbon, and potentially nutrients such as N and P as well as water. The coordinated nature of secondary cellular differentiation throughout the tree cambium means that the primary environmental influences on wood growth can be captured in a single radial file, making the problem of whole-tree growth dynamics eminently computable. Volume and mass growth of the stem can thus be treated as a function of the dynamics of a single radial file at some location on the stem, scaled to the whole tree using the summed stem, branches, and root surface areas to represent the entire secondary meristem. Apical meristems provide height and coarse root depth growth, and can use a similar approach as the secondary radial file to compute cellular differentiation. Other sinks, such as foliage and fine roots, can be included using approaches such as the pipe model. A parsimonious approach to scaling the radial file and an apical meristem to the whole-tree structure with internal labile carbon dynamics was described and tested by Hayat et al. (2017), with the ratio of apical to secondary meristem activity controlled by leaf canopy shading. This approach used single undifferentiated volumes for the meristems, but could easily be extended to represent daily xylogenesis along a radial file.

Assumptions regarding scaling of physiological feedback to the whole-tree level can be equally parsimonious as a first step. As discussed, these need to treat the influence of both C source supply on xylem differentiation and the feedback of growth on photosynthesis. The simplest mechanism to achieve this, and one consistent with physiological understanding (e.g., Smith and Stitt 2007), is to include one or more dynamic C reserve pools, which buffer supply and demand, and provide information on internal carbon status to source and sink processes. High levels of C reserves cause downregulation of photosynthesis and, potentially, upregulation of growth, depending on phenological and/or other controls. Key uncertainties are the precise relationships to use, the controls on reserve

dynamics (Dietze et al. 2014; Hartmann et al. 2018), and how feedback might interact with any internal dynamics of N and P and external factors such as soil water and incident light. However, as for the details of controls on xylogenetic processes, feedback processes can be represented as a set of first-order hypotheses and tested against a range of data sources (e.g., Würth et al. 2005; Furze et al. 2019; Smith et al. 2018).

There is clearly a need for more information on relationships between carbon supply and wood growth. However, elevated/reduced CO₂ experiments are difficult and expensive, and responses of seedlings in growth chambers may not reflect those in large mature trees. But there are other ways to manipulate C supply to radial meristems. These include girdling, phloem compression, and phloem chilling (Rademacher et al. 2019). In experiments on mature trees at Harvard Forest, for example, we are manipulating the supply of photoassimilates to stem sinks through phloem chilling, phloem compression, and girdling in order to investigate the response of xylogenesis (through weekly microcores) and NSC dynamics to variable carbon supply. The outcomes of these manipulations will be extremely informative for developing a model of whole-tree source-sink dynamics as envisaged here.

6 Implications for vegetation models

Inclusion of explicit wood growth and feedback on photosynthesis in trees is likely to have profound influences on the behaviour of DGVMs, especially their forecasts of future carbon uptake into durable biomass. The actual degree of influence will depend on the extent to which limitations to growth are stronger than those on photosynthesis, and over what timescales. At a minimum, it is likely that such an approach, if carefully implemented, will help reconcile model-data biases such as those due to lag effects (Keenan et al. 2012), which invoke temporal separations between source and sink processes (Seftigen et al. 2018; Rocha et al. 2006; Teets et al. 2018; Richardson et al. 2013). An additional important aspect is the distinction between volume and mass growth. Inventory-type assessments of tree productivity use volume changes to estimate mass changes, usually assuming fixed, species-specific values for wood density, carbon content, and allometric relationships. Model predictions of (carbon-based) NPP dynamics are then compared with these volume-derived observations. However, wood density varies significantly within and between growth rings, and between individuals of the same species, and moreover, there is very good evidence that significant reductions in wood density have occurred at large scales in recent decades due to environmental changes (Pretzsch et al. 2018). Furthermore,

wood carbon content is known to significantly vary from the widely used 50% of dry mass (e.g., Martin et al. 2018). A model which includes explicit xylogenesis, of the type envisaged here, will be capable of reproducing divergences between volume and mass changes, and may thus have major implications for the match between model and data more widely (Babst et al. 2018). Moreover, density changes have implications for hydrological functioning (including leaf area, stomatal conductance, and risk of cavitation), and mechanical support (Cannell and Dewar 1994), which can be built into our model approach dynamically (i.e., environmental factors can influence wood structure, which affects hydrodynamics and risk of breakage). In addition, explicit consideration of the stoichiometric requirements of secondary cell walls in the model could allow for the variation in carbon content to be taken into account.

However, we believe the implications of our approach will go beyond these issues, potentially challenging the current interpretation of historical C sinks on land and having major impacts on future forecasts. For example, the seeming inconsistencies between the top-down constraint of a large land C sink, and local observations of little, if any, increased plant growth, could be resolved by such an approach (Fatichi et al. 2019). Moreover, if a mechanistic yet relatively simple model of tree growth can be shown to have a major effect on DGVM behaviour, reconciling model-data biases and changing forecasts, then the role of photosynthesis in these models is greatly reduced. DGVMs tend to treat photosynthesis and the canopy light environment with great complexity, including vertical canopy gradients in physiology and radiation, and complex biochemical functions with demanding computational numerics to balance the supply and demand of CO₂ within leaves. This is far more detail than envisaged in our approach to growth processes, and therefore a balanced treatment of sources and sinks will make these models simpler as well as more realistic.

7 Key remaining gaps in knowledge and future developments

As mentioned, details of the relationship between the supply of photosynthate and the activity of differentiating xylem is critical yet remains poorly understood. Even in *Arabidopsis*, while considerable knowledge exists concerning the metabolic pathways involved in the conversion of sucrose to cell wall material, understanding the regulation of cell wall synthesis is still rudimentary (Verbančič et al. 2018). While synthesis is inhibited at low rates of sugar supply, the range over which this occurs, and the controls when C supply is saturating, remain unclear. More broadly, controls on cell wall synthesis include signalling

pathways and the regulation of genetic expression (Verbančič et al. 2018), which are largely outside the scope of DGVMs. However, observations in trees suggest influences from temperature and plant water content, which could be implemented empirically to allow characterisation of C sink strength at a cellular level (e.g., Antonova and Stasova 1997; Ziaco et al. 2014; Cuny and Rathgeber 2016; Björklund et al. 2017). Both the rate of synthesis and its duration are important, with the determination of the end of the maturation phase a key factor. Interestingly, this usually occurs before environmental conditions deteriorate to levels that would be expected to limit growth, implying strong phenological signalling. Implementing such controls mechanistically in a model of wood growth might be challenging, but is clearly of great importance, especially in the context of decoupling growth from source activity. Other features of wood anatomy to consider, but not discussed here, are the determination of cell types such as parenchyma and fibre cells, and the formation of heartwood.

Xylogenetic studies have largely focused on conifers, with their relatively simple wood structure, and therefore an important objective will be to extend this balanced source-sink model approach to other species. Indeed, tropical trees contain the majority of plant carbon (Houghton et al. 2009), and so future work needs to develop representations of wood development across a range of tree types and environmental conditions. The responses of wood development to future conditions, particularly with respect to hydraulic properties, will be a major determinant of the performance of individuals (cf., Pretzsch et al. 2018). Therefore, representing differences in wood formation and resulting anatomical structures between tree types and species (e.g., Spicer and Groover 2010) will be key for predicting future community dynamics. The complexity of angiosperm wood anatomy likely makes the level of detail possible in modelling conifer xylogenesis difficult to achieve across all species. We are therefore exploring approaches that treat zones of cells types, rather than individual cells, based on microcore observations of weekly growth dynamics in *Quercus rubra* and *Acer rubrum* at Harvard Forest, in combination with phloem chilling and compression treatments.

8 Conclusions

We have identified a need to explore the implications of explicit representation of wood growth processes in DGVMs and have outlined an approach for doing this. Our approach is to compute the daily growth of an individual tree based on a treatment of xylogenesis along a radial file, with dependencies on external and internal factors, and feedback on photosynthesis through labile carbon

contents. Scaling to the whole tree assumes this radial file represents all secondary growth, with tree size and shape determining the total meristem mass through simple allometric relationships. A key uncertainty concerns the response of xylem differentiation to carbon supply. Both wood formation dynamics and anatomical data from tree rings, especially where carbon supply is manipulated and labile concentrations measured, can be used to develop and test hypotheses. We anticipate that when scaled-up globally, a mechanistic representation of growth processes has the potential to significantly alter our interpretation of the historical carbon sink on land and greatly improve constraints on its likely future dynamics.

Acknowledgements ADF thanks numerous people for discussions around the ideas expressed here, in particular Flurin Babst, Soumaya Belmecheri, Henri Cuny, David Frank, Andrew Hackett-Pain, Christian Körner, Ben Poulter, and Valerie Trouet.

Funding ADF, PF, TTR, ADR, and RHT acknowledge support from the Natural Environment Research Council—National Science Foundation International Collaboration programme, under grants nos. NE/P011462/1 and DEB-1741585. ADR is also supported by NSF grant no. DEB-1237491. The UMR 1434 Silva is supported by a grant overseen by the French National Research Agency (ANR) as part of the “Investissements d’Avenir” programme (ANR-11-LABX-0002-01, Lab of Excellence ARBRE). PF acknowledges the project LOTFOR (Nr. 150205), supported by the Swiss National Foundation.

Data Availability Data sharing not applicable to this article as no datasets were generated or analysed during the current study.

Compliance with ethical standards

Conflict of interest The authors declare that they have no conflicts of interest.

Open Access This article is distributed under the terms of the Creative Commons Attribution 4.0 International License (<http://creativecommons.org/licenses/by/4.0/>), which permits unrestricted use, distribution, and reproduction in any medium, provided you give appropriate credit to the original author(s) and the source, provide a link to the Creative Commons license, and indicate if changes were made.

References

- Ainsworth EA, Bush DR (2011) Carbohydrate export from the leaf: a highly regulated process and target to enhance photosynthesis and productivity. *Plant Physiol* 155:64–69. <https://doi.org/10.1104/pp.110.167684>. <http://www.plantphysiol.org/cgi/doi/10.1104/pp.110.167684>
- Allen MT, Prusinkiewicz P, DeJong TM (2005) Using L-systems for modeling source-sink interactions, architecture and physiology of growing trees: the L-PEACH model. *New Phytol* 166:869–880. <https://doi.org/10.1111/j.1469-8137.2005.01348.x>. <http://doi.wiley.com/10.1111/j.1469-8137.2005.01348.x>

- Antonova GF, Stasova VV (1997) Effects of environmental factors on wood formation in larch (*Larix sibirica* Ldb.) stems. *Trees* 11:462–468. <https://doi.org/10.1007/PL00009687>. <http://link.springer.com/10.1007/PL00009687>
- Arora VK, Boer GJ, Friedlingstein P, Eby M, Jones CD, Christian JR, Bonan G, Bopp L, Brovkin V, Cadule P, Hajima T, Ilyina T, Lindsay K, Tjiputra JF, Wu T (2013) Carbon–concentration and carbon–climate feedbacks in CMIP5 Earth System Models. *J Clim* 26:5289–5314. <https://doi.org/10.1175/JCLI-D-12-00494.1>. <http://journals.ametsoc.org/doi/abs/10.1175/JCLI-D-12-00494.1>
- Babst F, Bodesheim P, Charney N, Friend AD, Girardin MP, Klesse S, Moore DJ, Seftigen K, Björklund J, Bouriaud O, Dawson A, DeRose RJ, Dietze MC, Eckes AH, Enquist B, Frank DC, Mahecha MD, Poulter B, Record S, Trouet V, Turton RH, Zhang Z, Evans ME (2018) When tree rings go global: Challenges and opportunities for retro- and prospective insight. *Quat Sci Rev* 197:1–20. <https://doi.org/10.1016/j.quascirev.2018.07.009>. <https://linkinghub.elsevier.com/retrieve/pii/S027379118300891>
- Balducci L, Cuny HE, Rathgeber CBK, Deslauriers A, Giovannelli A, Rossi S (2016) Compensatory mechanisms mitigate the effect of warming and drought on wood formation. *Plant Cell Environ* 39:1338–1352. <https://doi.org/10.1111/pce.12689>. <http://doi.wiley.com/10.1111/pce.12689>
- Bennett AC, McDowell NG, Allen CD, Anderson-Teixeira KJ (2015) Larger trees suffer most during drought in forests worldwide. *Nature Plants* 1:15,139. <https://doi.org/10.1038/nplants.2015.139>. <http://www.nature.com/articles/nplants2015139>
- Björklund J, Seftigen K, Schweingruber F, Fonti P, von Arx G, Bryukhanova MV, Cuny HE, Carrer M, Castagneri D, Frank DC (2017) Cell size and wall dimensions drive distinct variability of earlywood and latewood density in Northern Hemisphere conifers. *New Phytol* 216:728–740. <https://doi.org/10.1111/nph.14639>. <http://doi.wiley.com/10.1111/nph.14639>
- Cannell MGR, Dewar RC (1994) Carbon allocation in trees: a review of concepts for modelling. In: *Advances in Ecological Research*, vol 25. Elsevier, pp 59–104. [https://doi.org/10.1016/S0065-2504\(08\)60213-5](https://doi.org/10.1016/S0065-2504(08)60213-5). <https://linkinghub.elsevier.com/retrieve/pii/S0065250408602135>
- Castagneri D, Fonti P, von Arx G, Carrer M (2017) How does climate influence xylem morphogenesis over the growing season? Insights from long-term intra-ring anatomy in *Picea abies*. *Annals of Botany* 119:1011–1020. <https://doi.org/10.1093/aob/mcw274>. <https://academic.oup.com/aob/article-lookup/doi/10.1093/aob/mcw274>
- Cramer W, Bondeau A, Woodward FI, Prentice IC, Betts RA, Brovkin V, Cox PM, Fisher V, Foley JA, Friend AD, Kucharik C, Lomas MR, Ramankutty N, Sitch S, Smith B, White A, Young-Molling C (2001) Global response of terrestrial ecosystem structure and function to CO₂ and climate change: results from six dynamic global vegetation models. *Glob Chang Biol* 7:357–373. <https://doi.org/10.1046/j.1365-2486.2001.00383.x>. <https://doi.org/10.1046/j.1365-2486.2001.00383.x>
- Cuny HE, Rathgeber CBK (2016) Xylogenesis: coniferous trees of temperate forests are listening to the climate tale during the growing season but only remember the last words! *Plant Physiology* 171:306–317. <https://doi.org/10.1104/pp.16.00037>. <http://www.plantphysiol.org/lookup/doi/10.1104/pp.16.00037>
- Cuny HE, Rathgeber CBK, Kiessé TS, Hartmann FP, Barbeito I, Fournier M (2013) Generalized additive models reveal the intrinsic complexity of wood formation dynamics. *J Exp Bot* 64:1983–1994. <https://doi.org/10.1093/jxb/ert057>. <http://jxb.oxfordjournals.org/lookup/doi/10.1093/jxb/ert057>
- Cuny HE, Rathgeber CBK, Frank D, Fonti P, Fournier M (2014) Kinetics of tracheid development explain conifer tree-ring structure. *New Phytol* 203:1231–1241. <https://doi.org/10.1111/nph.12871>. <http://doi.wiley.com/10.1111/nph.12871>

- Cuny HE, Rathgeber CBK, Frank D, Fonti P, Mäkinen H, Prislan P, Rossi S, del Castillo EM, Campelo F, Vavřík H, Camarero JJ, Bryukhanova MV, Jyske T, Gričar J, Gryc V, De Luis M, Vieira J, Čufar K, Kirjyanov AV, Oberhuber W, Trembl V, Huang JG, Li X, Swidrak I, Deslauriers A, Liang E, Nöjd P, Gruber A, Nabais C, Morin H, Krause C, King G, Fournier M (2015) Woody biomass production lags stem-girth increase by over one month in coniferous forests. *Nature Plants* :15160. <https://doi.org/10.1038/nplants.2015.160>. <http://www.nature.com/articles/nplants2015160>
- Cuny HE, Fonti P, Rathgeber CBK, von Arx G, Peters RL, Frank DC (2019) Couplings in cell differentiation kinetics mitigate air temperature influence on conifer wood anatomy. *Plant, Cell & Environment* 42:1222–1232. <https://doi.org/10.1111/pce.13464>. <http://doi.wiley.com/10.1111/pce.13464>
- Dawes MA, Philipson CD, Fonti P, Bebi P, Hättenschwiler S, Hagedorn F, Rixen C (2015) Soil warming and CO₂ enrichment induce biomass shifts in alpine tree line vegetation. *Glob Chang Biol* 21:2005–2021. <https://doi.org/10.1111/gcb.12819>. <http://doi.wiley.com/10.1111/gcb.12819>
- Dietze MC, Sala A, Carbone MS, Czimeczik CI, Mantooth JA, Richardson AD, Vargas R (2014) Nonstructural carbon in woody plants. *Annu Rev Plant Biol* 65:667–687. <https://doi.org/10.1146/annurev-arplant-050213-040054>. <http://www.annualreviews.org/doi/abs/10.1146/annurev-arplant-050213-040054>
- Ellsworth DS, Anderson IC, Crous KY, Cooke J, Drake JE, Gherlenda AN, Gimeno TE, Macdonald CA, Medlyn BE, Powell JR, Tjoelker MG, Reich PB (2017) Elevated CO₂ does not increase eucalypt forest productivity on a low-phosphorus soil. *Nat Clim Change* 7:279–282. <https://doi.org/10.1038/nclimate3235>. <http://www.nature.com/articles/nclimate3235>
- Ethchells JP, Mishra LS, Kumar M, Campbell L, Turner SR (2015) Wood formation in trees is increased by manipulating PXY-regulated cell division. *Curr Biol* 25:1050–1055. <https://doi.org/10.1016/j.cub.2015.02.023>. <http://linkinghub.elsevier.com/retrieve/pii/S0960982215001621>
- Fatichi S, Leuzinger S, Körner C (2014) Moving beyond photosynthesis: from carbon source to sink-driven vegetation modeling. *New Phytol* 201:1086–1095. <https://doi.org/10.1111/nph.12614>. <http://doi.wiley.com/10.1111/nph.12614>
- Fatichi S, Pappas C, Zscheischler J, Leuzinger S (2019) Modelling carbon sources and sinks in terrestrial vegetation. *New Phytologist* 221:652–668. <https://doi.org/10.1111/nph.15451>. <http://doi.wiley.com/10.1111/nph.15451>
- Fonti P, Bryukhanova MV, Myglan VS, Kirjyanov AV, Naumova OV, Vaganov EA (2013) Temperature-induced responses of xylem structure of *Larix sibirica* (Pinaceae) from the Russian Altay. *Am J Bot* 100:1332–1343. <https://doi.org/10.3732/ajb.1200484>. <http://doi.wiley.com/10.3732/ajb.1200484>
- Franck N, Vaast P, Génard M, Dauzat J (2006) Soluble sugars mediate sink feedback down-regulation of leaf photosynthesis in field-grown *Coffea arabica*. *Tree Physiol* 26:517–525. <https://doi.org/10.1093/treephys/26.4.517>. <https://academic.oup.com/treephys/article-lookup/doi/10.1093/treephys/26.4.517>
- Friedlingstein P, Meinshausen M, Arora VK, Jones CD, Anav A, Liddicoat SK, Knutti R (2014) Uncertainties in CMIP5 climate projections due to carbon cycle feedbacks. *J Clim* 27:511–526. <https://doi.org/10.1175/JCLI-D-12-00579.1>. <http://journals.ametsoc.org/doi/abs/10.1175/JCLI-D-12-00579.1>
- Friend AD, Stevens AK, Knox RG, Cannell MGR (1997) A process-based, terrestrial biosphere model of ecosystem dynamics (Hybrid v3.0). *Ecol Model* 95:249–287. [https://doi.org/10.1016/S0304-3800\(96\)00034-8](https://doi.org/10.1016/S0304-3800(96)00034-8). <http://linkinghub.elsevier.com/retrieve/pii/S0304380096000348>
- Friend AD, White A (2000) Evaluation and analysis of a dynamic terrestrial ecosystem model under preindustrial conditions at the global scale. *Glob. Biogeochem Cycles* 14:1173–1190. <https://doi.org/10.1029/1999GB900085>. <https://doi.org/10.1029/1999GB900085>
- Friend AD, Lucht W, Rademacher TT, Keribin R, Betts R, Cadule P, Ciais P, Clark DB, Dankers R, Falloon PD, Ito A, Kahana R, Kleidon A, Lomas MR, Nishina K, Ostberg S, Pavlick R, Peylin P, Schaphoff S, Vuichard N, Warszawski L, Wiltshire A, Woodward FI (2014) Carbon residence time dominates uncertainty in terrestrial vegetation responses to future climate and atmospheric CO₂. *Proc Natl Acad Sci* 111:3280–3285. <https://doi.org/10.1073/pnas.1222477110>. <http://www.pnas.org/lookup/doi/10.1073/pnas.1222477110>
- Fritts HC, Blasing TJ, Hayden BP, Kutzbach JE (1971) Multivariate techniques for specifying tree-growth and climate relationships and for reconstructing anomalies in paleoclimate. *J Appl Meteorol* 10:845–864. [https://doi.org/10.1175/1520-0450\(1971\)010<0845:MTFSTG>2.0.CO;2](https://doi.org/10.1175/1520-0450(1971)010<0845:MTFSTG>2.0.CO;2)
- Furze ME, Huggett BA, Aubrecht DM, Stolz CD, Carbone MS, Richardson AD (2019) Whole-tree nonstructural carbohydrate storage and seasonal dynamics in five temperate species. *New Phytologist* 221:1466–1477. <https://doi.org/10.1111/nph.15462>. <http://doi.wiley.com/10.1111/nph.15462>
- Guillemot J, Francois C, Hmimina G, Dufrêne E, Martin-StPaul NK, Soudani K, Marie G, Ourcival JM, Delpierre N (2017) Environmental control of carbon allocation matters for modelling forest growth. *New Phytol* 214:180–193. <https://doi.org/10.1111/nph.14320>. <http://doi.wiley.com/10.1111/nph.14320>
- Hajima T, Kawamiya M, Watanabe M, Kato E, Tachiiri K, Sugiyama M, Watanabe S, Okajima H, Ito A (2014) Modeling in Earth system science up to and beyond IPCC AR5. *Progress in Earth and Planetary Science* 1:29. <https://doi.org/10.1186/s40645-014-0029-y>. <http://www.progearthplanetosci.com/content/1/1/29>
- Hartmann FP, K Rathgeber CB, Fournier M, Moulia B (2017) Modelling wood formation and structure: power and limits of a morphogenetic gradient in controlling xylem cell proliferation and growth. *Ann For Sci* 74 :14. <https://doi.org/10.1007/s13595-016-0613-y>. <http://link.springer.com/10.1007/s13595-016-0613-y>
- Hartmann H, Adams HD, Hammond WM, Hoch G, Landhäusser SM, Wiley E, Zaehle S (2018) Identifying differences in carbohydrate dynamics of seedlings and mature trees to improve carbon allocation in models for trees and forests. *Environ Exp Bot* 152:7–18. <https://doi.org/10.1016/j.envexpbot.2018.03.011>. <https://linkinghub.elsevier.com/retrieve/pii/S0098847218303915>
- Hayat A, Hackett-Pain AJ, Pretzsch H, Rademacher TT, Friend AD (2017) Modeling tree growth taking into account carbon source and sink limitations. *Frontiers in Plant Science* 8:182. <https://doi.org/10.3389/fpls.2017.00182>. <http://journal.frontiersin.org/article/10.3389/fpls.2017.00182/full>
- Hoch G (2015) Carbon reserves as indicators for carbon limitation in trees. In: Lüttge U, Beyschlag W (eds) *Progress in Botany*, vol 76. Springer International Publishing, Cham, pp 321–346. https://doi.org/10.1007/978-3-319-08807-5_13. http://link.springer.com/10.1007/978-3-319-08807-5_13
- Houghton RA, Hall F, Goetz SJ (2009) Importance of biomass in the global carbon cycle. *J Geophys Res Biogeosci* 114:G00E03. <https://doi.org/10.1029/2009JG000935>. <http://doi.wiley.com/10.1029/2009JG000935>
- Hsiao TC (1973) Plant responses to water stress. *Annu Rev Plant Physiol* 24:519–570. <https://doi.org/10.1146/annurev.pp.24.060173.002511>. <http://www.annualreviews.org/doi/10.1146/annurev.pp.24.060173.002511>

- Iglesias DJ, Lliso I, Tadeo FR, Talon M (2002) Regulation of photosynthesis through source: sink imbalance in citrus is mediated by carbohydrate content in leaves. *Physiol Plant* 116:563–572. <https://doi.org/10.1034/j.1399-3054.2002.1160416.x>. <http://doi.wiley.com/10.1034/j.1399-3054.2002.1160416.x>
- Jones C, Robertson E, Arora V, Friedlingstein P, Shevliakova E, Bopp L, Brovkin V, Hajima T, Kato E, Kawamiya M, Liddicoat S, Lindsay K, Reick CH, Roelandt C, Segschneider J, Tjiputra J (2013) Twenty-first-century compatible CO₂ emissions and airborne fraction simulated by CMIP5 Earth system models under four representative concentration pathways. *J Clim* 26:4398–4413. <https://doi.org/10.1175/JCLI-D-12-00554.1>. <http://journals.ametsoc.org/doi/abs/10.1175/JCLI-D-12-00554.1>
- Keenan TF, Williams CA (2018) The terrestrial carbon sink. *Annu Rev Environ Resour* 43:219–243. <https://doi.org/10.1146/annurev-environ-102017-030204>. <https://www.annualreviews.org/doi/10.1146/annurev-environ-102017-030204>
- Keenan TF, Baker IC, Barr A, Ciais P, Davis K, Dietze M, Dragoni D, Gough CM, Grant R, Hollinger D, Hufkens K, Poulter B, McCaughey H, Raczka B, Ryu Y, Schaefer K, Tian H, Verbeeck H, Zhao M, Richardson AD (2012) Terrestrial biosphere model performance for inter-annual variability of land-atmosphere CO₂ exchange. *Glob Chang Biol* 18:1971–1987. <https://doi.org/10.1111/j.1365-2486.2012.02678.x>. <http://doi.wiley.com/10.1111/j.1365-2486.2012.02678.x>
- Kirschbaum MU (2011) Does enhanced photosynthesis enhance growth? Lessons learned from CO₂ enrichment studies. *Plant Physiol* 155:117–124. <https://doi.org/10.1104/pp.110.166819>
- Krapp A, Stitt M (1995) An evaluation of direct and indirect mechanisms for the “sink-regulation” of photosynthesis in spinach: Changes in gas exchange, carbohydrates, metabolites, enzyme activities and steady-state transcript levels after cold-girdling source leaves. *Planta* 195:313–323. <https://doi.org/10.1007/BF00202587>. <http://link.springer.com/10.1007/BF00202587>
- Krinner G, Viovy N, de Noblet-Ducoudré N, Ogée J, Polcher J, Friedlingstein P, Ciais P, Sitch S, Prentice IC (2005) A dynamic global vegetation model for studies of the coupled atmosphere-biosphere system. *Global Biogeochemical Cycles* 19:GB1015. <https://doi.org/10.1029/2003GB002199>. <http://doi.wiley.com/10.1029/2003GB002199>
- Körner C (2015) Paradigm shift in plant growth control. *Curr Opin Plant Biol* 25:107–114. <https://doi.org/10.1016/j.pbi.2015.003>. <http://linkinghub.elsevier.com/retrieve/pii/S1369526615000540>
- Le Quéré C, Andrew RM, Friedlingstein P, Sitch S, Pongratz J, Manning AC, Korsbakken JI, Peters GP, Canadell JG, Jackson RB, Boden TA, Tans PP, Andrews OD, Arora VK, Bakker DCE, Barbero L, Becker M, Betts RA, Bopp L, Chevallier F, Chini LP, Ciais P, Cosca CE, Cross J, Currie K, Gasser T, Harris I, Hauck J, Haverd V, Houghton RA, Hunt CW, Hurtt G, Ilyina T, Jain AK, Kato E, Kautz M, Keeling RF, Klein Goldewijk K, Körtzinger A, Landschützer P, Lefèvre N, Lenton A, Lienert S, Lima I, Lombardozzi D, Metz N, Millero F, Monteiro PMS, Munro DR, Nabel JEMS, Si Nakaoka, Nojiri Y, Padin XA, Peregon A, Pfeil B, Pierrot D, Poulter B, Rehder G, Reimer J, Rödenbeck C, Schwinger J, Séférian R, Skjelvan I, Stocker BD, Tian H, Tilbrook B, Tubiello FN, van der Laan-Luijckx IT, van der Werf GR, van Heuven S, Viovy N, Vuichard N, Walker AP, Watson AJ, Wiltshire AJ, Zaehle S, Zhu D (2018) Global carbon budget 2017. *Earth Syst Sci Data* 10:405–448. <https://doi.org/10.5194/essd-10-405-2018>. <https://www.earth-syst-sci-data.net/10/405/2018/>
- Leuzinger S, Manusch C, Bugmann H, Wolf A (2013) A sink-limited growth model improves biomass estimation along boreal and alpine tree lines. *Glob Ecol Biogeogr* 22:924–932. <https://doi.org/10.1111/geb.12047>. <http://onlinelibrary.wiley.com/doi/10.1111/geb.12047/abstract>
- Lloyd J, Farquhar GD (1996) The CO₂ dependence of photosynthesis, plant growth responses to elevated atmospheric CO₂ concentrations and their interaction with soil nutrient status. I. General principles and forest ecosystems. *Funct Ecol* 10:4–32. <https://doi.org/10.1046/j.1365-2435.1999.00350.x>
- Lovenduski NS, Bonan GB (2017) Reducing uncertainty in projections of terrestrial carbon uptake. *Environ Res Lett* 12:044020. <https://doi.org/10.1088/1748-9326/aa66b8>
- Martin AR, Doraisami M, Thomas SC (2018) Global patterns in wood carbon concentration across the world’s trees and forests. *Nat Geosci* 11:915–920. <https://doi.org/10.1038/s41561-018-0246-x>. <http://www.nature.com/articles/s41561-018-0246-x>
- Millard P, Sommerkorn M, Grelet GA (2007) Environmental change and carbon limitation in trees: a biochemical, ecophysiological and ecosystem appraisal. *New Phytol* 175:11–28. <https://doi.org/10.1111/j.1469-8137.2007.02079.x>. <http://doi.wiley.com/10.1111/j.1469-8137.2007.02079.x>
- Mouliat B, Coutand C, Julien JL (2015) Mechanosensitive control of plant growth: bearing the load, sensing, transducing, and responding. *Front Plant Sci* 6:52. <https://doi.org/10.3389/fpls.2015.00052>
- Muller B, Pantin F, Génard M, Turc O, Freixes S, Piques M, Gibon Y (2011) Water deficits uncouple growth from photosynthesis, increase C content, and modify the relationships between C and growth in sink organs. *J Exp Bot* 62:1715–1729. <https://doi.org/10.1093/jxb/erq438>. <https://academic.oup.com/jxb/article-lookup/doi/10.1093/jxb/erq438>
- Parent B, Turc O, Gibon Y, Stitt M, Tardieu F (2010) Modelling temperature-compensated physiological rates, based on the co-ordination of responses to temperature of developmental processes. *J Exp Bot* 61:2057–2069. <https://doi.org/10.1093/jxb/erq003>. <https://academic.oup.com/jxb/article-lookup/doi/10.1093/jxb/erq003>
- Paul MJ, Foyer CH (2001) Sink regulation of photosynthesis. *J Exp Bot* 52:1383–1400. <https://doi.org/10.1093/jexbot/52.360.1383>. <https://academic.oup.com/jxb/article-lookup/doi/10.1093/jexbot/52.360.1383>
- Pretzsch H, Biber P, Schütze G, Kemmerer J, Uhl E (2018) Wood density reduced while wood volume growth accelerated in Central European forests since 1870. *For Ecol Manag* 429:589–616. <https://doi.org/10.1016/j.foreco.2018.07.045>. <https://linkinghub.elsevier.com/retrieve/pii/S0378112718310600>
- Quetin GR, Swann ALS (2018) Sensitivity of leaf area to interannual climate variation as a diagnostic of ecosystem function in CMIP5 carbon cycle models. *J Clim* 31:8607–8625. <https://doi.org/10.1175/JCLI-D-17-0580.1>. <http://journals.ametsoc.org/doi/10.1175/JCLI-D-17-0580.1>
- Rademacher TT, Basler D, Eckes-Shephard AH, Fonti P, Friend AD, Le Moine J, Richardson AD (2019) Using direct phloem transport manipulation to advance understanding of carbon dynamics in forest trees. *Front For Glob Change*. <https://doi.org/10.3389/ffgc.2019.00011>. <https://www.frontiersin.org/articles/10.3389/ffgc.2019.00011/abstract>
- Rathgeber CBK, Cuny HE, Fonti P (2016) Biological basis of tree-ring formation: a crash course. *Frontiers in Plant Science* 7:734. <https://doi.org/10.3389/fpls.2016.00734>. <http://journal.frontiersin.org/Article/10.3389/fpls.2016.00734/abstract>
- Richardson AD, Carbone MS, Keenan TF, Czimczik CI, Hollinger DY, Murakami P, Schaberg PG, Xu X (2013) Seasonal dynamics and age of stemwood nonstructural carbohydrates in temperate forest trees. *New Phytol* 197:850–861. <https://doi.org/10.1111/nph.12042>. <http://doi.wiley.com/10.1111/nph.12042>
- Rocha AV, Goulden ML, Dunn AL, Wofsy SC (2006) On linking inter-annual tree ring variability with observations of whole-forest CO₂ flux. *Glob Chang Biol* 12:1378–1389. <https://doi.org/10.1111/j.1365-2486.2006.01179.x>. <http://doi.wiley.com/10.1111/j.1365-2486.2006.01179.x>

- Rossi S, Deslauriers A, Anfodillo T (2006) Assessment of cambial activity and xylogenesis by microsampling tree species: an example at the alpine timberline. *IAWA J* 27:383–394. <https://doi.org/10.1163/22941932-90000161>. <http://booksandjournals.brillonline.com/content/journals/10.1163/22941932-90000161>
- Rossi S, Anfodillo T, Čufar K, Cuny HE, Deslauriers A, Fonti P, Frank D, Gričar J, Gruber A, Huang JG, Jyske T, Kašpar J, King G, Krause C, Liang E, Mäkinen H, Morin H, Nöjd P, Oberhuber W, Prislán P, Rathgeber CB, Saracino A, Swidrak I, Treml V (2016) Pattern of xylem phenology in conifers of cold ecosystems at the Northern Hemisphere. *Global Change Biology* 22:3804–3813. <https://doi.org/10.1111/gcb.13317>. <http://doi.wiley.com/10.1111/gcb.13317>
- Seftigen K, Frank DC, Björklund J, Babst F, Poulter B (2018) The climatic drivers of normalized difference vegetation index and tree-ring-based estimates of forest productivity are spatially coherent but temporally decoupled in Northern Hemispheric forests. *Global Ecology and Biogeography* 27:1352–1365. <https://doi.org/10.1111/geb.12802>. <http://doi.wiley.com/10.1111/geb.12802>
- Sellers PJ, Randall DA, Collatz GJ, Berry JA, Field CB, Dazlich DA, Zhang C, Collelo GD, Bounoua L (1996) A revised land surface parameterization (SiB2) for atmospheric GCMS. Part I: model formulation. *J Clim* 9:676–705. [https://doi.org/10.1175/1520-0442\(1996\)009<0676:ARLSPF>2.0.CO;2](https://doi.org/10.1175/1520-0442(1996)009<0676:ARLSPF>2.0.CO;2)
- Sitch S, Smith B, Prentice IC, Arneeth A, Bondeau A, Cramer W, Kaplan JO, Levis S, Lucht W, Sykes MT, Thonicke K, Venevsky S (2003) Evaluation of ecosystem dynamics, plant geography and terrestrial carbon cycling in the LPJ dynamic global vegetation model. *Glob Chang Biol* 9:161–185. <https://doi.org/10.1046/j.1365-2486.2003.00569.x>. <http://doi.wiley.com/10.1046/j.1365-2486.2003.00569.x>
- Smith AM, Stitt M (2007) Coordination of carbon supply and plant growth. *Plant Cell Environ* 30:1126–1149. <https://doi.org/10.1111/j.1365-3040.2007.01708.x>. <http://doi.wiley.com/10.1111/j.1365-3040.2007.01708.x>
- Smith MG, Miller RE, Arndt SK, Kasel S, Bennett LT (2018) Whole-tree distribution and temporal variation of non-structural carbohydrates in broadleaf evergreen trees. *Tree Physiol* 38:570–581. <https://doi.org/10.1093/treephys/tpx141>. <https://academic.oup.com/treephys/article/38/4/570/4587990>
- Spicer R, Groover A (2010) Evolution of development of vascular cambium and secondary growth. *New Phytol* 186:577–592. <https://doi.org/10.1111/j.1469-8137.2010.03236.x>. <http://doi.wiley.com/10.1111/j.1469-8137.2010.03236.x>
- Stephenson NL, Das AJ, Condit R, Russo SE, Baker PJ, Beckman NG, Coomes DA, Lines ER, Morris WK, Rüger N, Álvarez E, Blundo C, Bunyavechewin S, Chuyong G, Davies SJ, Duque Á, Ewango CN, Flores O, Franklin JF, Grau HR, Hao Z, Harmon ME, Hubbell SP, Kenfack D, Lin Y, Makana J-R, Malizia A, Malizia LR, Pabst RJ, Pongpattananurak N, Su S-H, Sun I-F, Tan S, Thomas D, van Mantgem PJ, Wang X, Wiser SK, Zavala MA (2014) Rate of tree carbon accumulation increases continuously with tree size. *Nature* 507:90–93. <https://doi.org/10.1038/nature12914>. <http://www.nature.com/articles/nature12914>
- Teets A, Fraver S, Hollinger DY, Weiskittel AR, Seymour RS, Richardson AD (2018) Linking annual tree growth with eddy-flux measures of net ecosystem productivity across twenty years of observation in a mixed conifer forest. *Agric For Meteorol* 249:479–487. <https://doi.org/10.1016/j.agrformet.2017.08.007>. <https://linkinghub.elsevier.com/retrieve/pii/S0168192317302630>
- Thornley JHM (1972) A model to describe the partitioning of photosynthate during vegetative plant growth. *Ann Bot* 36:419–430. <https://doi.org/10.1093/oxfordjournals.aob.a084601>. <https://academic.oup.com/aob/article/19/1039/A>
- Vaganov EA, Hughes MK, Shashkin AV (2006) Growth dynamics of conifer tree rings: images of past and future environments. No 183 in *Ecological studies*. Springer, Berlin
- Verbančič J, Lunn JE, Stitt M, Persson S (2018) Carbon supply and the regulation of cell wall synthesis. *Mol Plant* 11:75–94. <https://doi.org/10.1016/j.molp.2017.10.004>
- Wang YP, Law RM, Pak B (2010) A global model of carbon, nitrogen and phosphorus cycles for the terrestrial biosphere. *Biogeosciences* 7:2261–2282. <https://doi.org/10.5194/bg-7-2261-2010>. <http://www.biogeosciences.net/7/2261/2010/>
- Wodzicki TJ (1971) Mechanism of xylem differentiation in *Pinus sylvestris* L. *J Exp Bot* 22:670–687. <https://doi.org/10.1093/jxb/22.3.670>. <https://academic.oup.com/jxb/article-lookup/doi/10.1093/jxb/22.3.670>
- Woodward FI (2002) Potential impacts of global elevated CO₂ concentrations on plants. *Curr Opin Plant Biol* 5:207–211. [https://doi.org/10.1016/S1369-5266\(02\)00253-4](https://doi.org/10.1016/S1369-5266(02)00253-4)
- Würth MKR, Peláez-Riedl S, Wright SJ, Körner C (2005) Non-structural carbohydrate pools in a tropical forest. *Oecologia* 143:11–24. <https://doi.org/10.1007/s00442-004-1773-2>. <http://link.springer.com/10.1007/s00442-004-1773-2>
- Yan BF, Duan W, Liu GT, Xu HG, Wang LJ, Li SH (2013) Response of bean (*Vicia faba* L.) plants to low sink demand by measuring the gas exchange rates and chlorophyll *a* fluorescence kinetics. *PLoS ONE* 8:e80770. <https://doi.org/10.1371/journal.pone.0080770>. <https://dx.plos.org/10.1371/journal.pone.0080770>
- Zaehle S, Friend AD (2010) Carbon and nitrogen cycle dynamics in the 2-CN land surface model: 1. Model description, site-scale evaluation, and sensitivity to parameter. *Global Biogeochem Cycles* 24:GB1005. <https://doi.org/10.1029/2009GB003521>. <http://doi.wiley.com/10.1029/2009GB003521>
- Zaehle S, Friedlingstein P, Friend AD (2010) Terrestrial nitrogen feedbacks may accelerate future climate change. *Geophys Res Lett* 37:L01401. <https://doi.org/10.1029/2009GL041345>. <http://doi.wiley.com/10.1029/2009GL041345>
- Ziaco E, Biondi F, Rossi S, Deslauriers A (2014) Climatic influences on wood anatomy and tree-ring features of Great Basin conifers at a new mountain observatory. *Appl Plant Sci* 2:1400054. <https://doi.org/10.3732/apps.1400054>. <http://doi.wiley.com/10.3732/apps.1400054>
- Ziaco E, Biondi F, Heinrich I (2016) Wood cellular dendroclimatology: testing new proxies in Great Basin bristlecone pine. *Frontiers in Plant Science* 7:1602. <https://doi.org/10.3389/fpls.2016.01602>. <http://journal.frontiersin.org/article/10.3389/fpls.2016.01602/full>
- Zuidema PA, Poulter B, Frank DC (2018) A wood biology agenda to support global vegetation modelling. *Trends Plant Sci* 23:1006–1015. <https://doi.org/10.1016/j.tplants.2018.08.003>. <https://linkinghub.elsevier.com/retrieve/pii/S1360138518301699>

Publisher's note Springer Nature remains neutral with regard to jurisdictional claims in published maps and institutional affiliations.

Affiliations

Andrew D. Friend¹  · Annemarie H. Eckes-Shephard¹ · Patrick Fonti² · Tim T. Rademacher^{3,4,5} · Cyrille B. K. Rathgeber⁶ · Andrew D. Richardson^{3,4} · Rachael H. Turton^{7,8}

- ¹ Department of Geography, University of Cambridge, Downing Place, Cambridge CB2 3EN, UK
- ² Swiss Federal Institute for Forest, Snow and Landscape Research, CH-8903 Birmensdorf, Switzerland
- ³ School of Informatics, Computing, and Cyber Systems, Northern Arizona University, Flagstaff, AZ 86011, USA
- ⁴ Center for Ecosystem Science and Society, Northern Arizona University, Flagstaff, AZ 86011, USA
- ⁵ Department of Organismic and Evolutionary Biology, Harvard University, Cambridge, MA, 02138, USA
- ⁶ Université de Lorraine, AgroParisTech, INRA, Silva, F-54000 Nancy, France
- ⁷ Scott Polar Research Institute, University of Cambridge, Lensfield Road, Cambridge, CB2 1ER, UK
- ⁸ British Antarctic Survey, Natural Environment Research Council, Madingley Road, Cambridge, CB3 0ET, UK