

# Online Research @ Cardiff

This is an Open Access document downloaded from ORCA, Cardiff University's institutional repository: <http://orca.cf.ac.uk/2878/>

This is the author's version of a work that was submitted to / accepted for publication.

Citation for final published version:

Hosoda, Takamichi and Disney, Stephen Michael 2006. On variance amplification in a three-echelon supply chain with minimum mean square error forecasting. *Omega* 34 (4) , pp. 344-358. 10.1016/j.omega.2004.11.005 file

Publishers page:

Please note:

Changes made as a result of publishing processes such as copy-editing, formatting and page numbers may not be reflected in this version. For the definitive version of this publication, please refer to the published source. You are advised to consult the publisher's version if you wish to cite this paper.

This version is being made available in accordance with publisher policies. See <http://orca.cf.ac.uk/policies.html> for usage policies. Copyright and moral rights for publications made available in ORCA are retained by the copyright holders.



# On variance amplification in a three-echelon supply chain with minimum mean square error forecasting

Takamichi Hosoda<sup>†</sup>, and Stephen M. Disney

## Abstract

We analyse a three echelon supply chain model. First-order autoregressive end consumer demand is assumed. We obtain exact analytical expressions for bullwhip and net inventory variance at each echelon in the supply chain. All of the three supply chain participants employ the order-up-to policy with the minimum mean square error forecasting scheme. After demonstrating that the character of the stochastic ordering process observed at each level of the supply chain is mathematically tractable, we show that the upper stream participants have complete information of the market demand process. Then we quantify the bullwhip produced by the system, together with the amplification ratios of the variance of the net inventory levels. Our analysis reveals that the level of the supply chain has no impact upon the bullwhip effect, rather bullwhip is determined by the accumulated lead-time from the customer and the local replenishment lead-time. We also find that the conditional variance of the forecast error over the lead-time is identical to the variance of the net inventory levels and that the net inventory variance is dominated by the local replenishment lead-time.

## Index Terms

Bullwhip effect; order-up-to policy; inventory variance; information sharing; supply chain management; minimum mean square error forecast.

## I. INTRODUCTION

The bullwhip effect, a well known phenomena in supply chain management was first popularised by Forrester [1], and various ways of quantifying bullwhip have been suggested. Chen *et al.* [2] suggest using  $\sigma_O^2/\sigma_D^2$ , where  $\sigma_D^2$  denotes the variance of demand and  $\sigma_O^2$  refers to the variance of orders placed by a retailer. Simply, this equation represents the ratio of the input variance to the output variance. Because of its simplicity and understandability, many researchers have adopted this equation to describe the magnitude of bullwhip (e.g. [3], [4], [5]). However, Disney and Towill [6] argue that this equation is only one half of the bullwhip problem as the replenishment rule

<sup>†</sup> Corresponding author. The authors are with the Logistics Systems Dynamics Group, Cardiff Business School, Cardiff University, Aberconway Building, Colum Drive, Cardiff CF10 3EU, Wales, UK (email: hosodat@cardiff.ac.uk; disneysm@cardiff.ac.uk) Tel: +44(0)29 2087 6083; Fax: +44(0)29 2087 4301

also influences the inventory dynamics. They suggest that  $\sigma_{NS}^2/\sigma_D^2$ , where  $\sigma_{NS}^2$  denotes the variance of the net inventory levels should also be considered. The net inventory is the on-hand inventory, that is, the stock actually you have, minus any backorders.

Inspired by Lee *et al.*'s [7] model structure, we investigate a sequential three echelon supply chain in which the demand in a market place follows a first-order autoregressive (AR(1)) process. The participants in the supply chain are the retailer, the distributor and the manufacturer. Moreover, we assume that each participant adopts the order-up-to (OUT) policy with a minimum mean square error forecasting (MMSE) scheme (Fig. 1). Our research herein is concerned with how the structure of the stochastic demand process evolves as the orders move up the supply chain. We measure the magnitude of the bullwhip effect using  $\sigma_O^2/\sigma_D^2$  to quantify order variance and  $\sigma_{NS}^2/\sigma_D^2$  to quantify net inventory variance. The net inventory variance measure is of importance as it allows us to determine the necessary safety stock level to achieve a required service level such as a fill-rate or availability target.

It is well recognised that the information sharing has an impact on the dynamics of a supply chain. A number of research papers assume that the retailer uses an exponential weighted moving average (EWMA) forecasting method even though an AR(1) demand process is assumed in their models (e.g. [8], [9]).<sup>1</sup> Here, a natural question arises: Does the benefit of information sharing still exist, if the retailer adopts the MMSE forecasting scheme? Lee *et al.* [7] use the MMSE scheme in a one retailer and one manufacturer supply chain model. An AR(1) demand process and order-up-to policy with an MMSE forecasting scheme at retailer is assumed. Under the constraint that the manufacturer employs only the latest order from the retailer, they suggest that there is a value of demand information sharing. On the other hand, Raghunathan [10] argues that without up-to-date information sharing, the manufacturer can still forecast the orders placed by the retailer correctly because the manufacturer already has enough information; it is all contained in historical ordering data.

In addition, some researchers (e.g. [3], [11]) recognise that for the ordering policy presented in Lee *et al.* [7], the replenishment order placed by the retailer follows an ARMA(1,1) process, whose specification is a function of the autoregressive parameter of demand and the replenishment lead-time. The most significant difference between these pioneering papers and this contribution is that we consider not only the transformation of the demand process and the order variance amplification (bullwhip), but also the amplification of the net inventory variance in a three echelon supply chain model without making an approximation, as it is common. The quantified net inventory variance at each echelon enables us to recognise the relationship between the demand pattern, the lead-time, the number of echelons to the end consumer, the forecast error, and the variance of the net inventory levels.

Remarking upon our methodology, we will use a combination of statistical approaches, discrete control theory and simulation. Using these approaches together we will achieve some understanding of a fairly complex model. The statistical approach is very useful for gaining insight into the structure of the ordering process as it moves up the supply chain. However the statistical approach will become rather unmanageable when we consider the

<sup>1</sup>From practical point of view, this assumption of exponential smoothing forecast methods seems reasonable because in the real business world the exponential smoothing forecast method is widely used as it is computationally efficient, mathematically tractable and readily understood.

net inventory variance as the expressions for the covariances between the states of the system are very complex. However, with control theory techniques, these intractable expressions are avoided altogether. Simulation will also play an important role<sup>2</sup>; quickly verifying our model and its workings.

Our paper is organised as follows. In the next two sections, the demand model and the ordering policy model are introduced. We will then introduce our three echelon supply chain model. In Section V, we analyse the bullwhip ratio in the supply chain. The measurement of net inventory variance amplification ratio is derived by using a control engineering methodology. We conclude in Section VII.

## II. THE DEMAND MODEL

Let us assume the demand pattern faced by the retailer is an AR(1) process. The AR(1) demand process assumption is common when autocorrelation exists among the demand process. Many researchers employ this assumption (e.g. [2], [3], [5], [7], [8], [9], [12], [13], [14], [15]). The formulation of AR(1) process is given by

$$D_t = d + \rho D_{t-1} + \varepsilon_t, \quad (1)$$

where  $D_t$  is the demand at time period  $t$ ,  $\rho$  is the autoregressive (AR) parameter,  $-1 < \rho < 1$ , and  $\varepsilon_t$  is a i.i.d. white noise process with mean zero and variance  $\sigma_\varepsilon^2$ . We note that this white noise processes can be drawn from any continuous distribution, e.g. normal, log-normal, gamma, exponential *etc.* We may set  $d = 0$  without loss of generality, thus the long term mean of the demand rate is zero. This has the advantage of not having an initial transient response. The general expression for the variance of the AR(1) process is

$$\sigma_{\text{AR}(1)}^2 = \frac{\sigma_\varepsilon^2}{1 - \rho^2}.$$

## III. THE ORDERING POLICY MODEL

Vassian [16] shows the ordering policy represented by (2) minimises the variance of the net inventory levels over time,

$$O_t = \hat{D}_t^l - \text{WIP}_t - \text{NS}_t, \quad (2)$$

where  $O_t$  is the order quantity placed at time period  $t$ ,  $\hat{D}_t^l$  is the conditional estimate of the total demand over the lead-time,  $l$ ,  $\text{WIP}_t$  is the total orders which are already placed but not yet received, and  $\text{NS}_t$  is the net inventory level at the end of period  $t$ .  $\text{WIP}_t$  can be expressed by;

$$\text{WIP}_t = \begin{cases} 0 & \text{if the lead-time is } 1, \\ \sum_{i=1}^{l-1} O_{t-i} & \text{otherwise.} \end{cases} \quad (3)$$

Since the net inventory is the on-hand inventory minus backorders,  $\text{NS}_t$  can be negative. Under the condition that a review period and the lead-time are constant,  $\text{NS}_t$  can be described as

$$\text{NS}_t = \text{NS}_{t-1} + O_{t-l} - D_t. \quad (4)$$

<sup>2</sup>Interested readers may visit to our web-site and experience the variance amplification using a simple supply chain simulation model at <http://www.bullwhip.co.uk>.

This equation assumes that  $O_{t-l}$ , which is received at the beginning of time period  $t$ , fulfils the demand at time period  $t$ .

#### A. Order-up-to Policy

The OUT policy can be represented with two equations;

$$O_t = D_t + (S_t - S_{t-1}), \quad (5)$$

$$S_t = \hat{D}_t^l + k\hat{\sigma}_t, \quad (6)$$

where  $S_t$  is the OUT level at time period  $t$ , and  $\hat{\sigma}_t$  is a conditional estimate of the standard deviation of the forecast error over the lead-time. This policy allows  $O_t$  to be negative, in which case we assume that excess inventory is returned without penalty as commonly assumed (see, [2], [3], [12], [13], [14] for example).  $k$  is a chosen constant to meet a desired service level such as the fill-rate or availability objective. Note that the OUT policy expressed as (5) and (6) has been used in several papers (e.g. [3], [5], [7]). Interestingly, (2) and (5) are identical (The proof is provided in Appendix I). In this section, we use (5) because of its simplicity. (2) is used to generate the block diagram in Fig. 8.

#### B. The Relationship Between the Net Inventory Variance and the Forecast Error over the Lead-time

The OUT policy ensures that the variance of net inventory levels and the variance of forecast error over the lead-time are equal. This fact originates in [16]. We may restate (4) as

$$NS_t = \hat{D}_{t-l}^l - \sum_{i=1}^l D_{t-l+i},$$

as shown in Appendix I. The RHS of the above equation clearly represents the forecast error over the lead-time. This result means that the forecast error made at time period  $t-l$  is the same as the net stock inventory at time period  $t$ . Therefore, when the time horizon is infinite, the variance of the net inventory levels is equal to the variance of forecast error over the lead-time. Vassian [16] also shows that if an order is placed according to the policy described by (2), the variance of the net inventory levels is minimised for the forecasting policy employed. Therefore, the ordering policy represented by (2) or (5) ensures the variance of the net inventory levels is both minimised and identical to the variance of the forecast error over the lead-time. This fact allows us to compute the variance of the forecast errors over the lead-time instead of computing the variance of the net inventory levels directly (for example, see [17]). This result also highlights that an MMSE forecast scheme is an essential ingredient to minimise inventory in supply chains.

### IV. OUR THREE ECHELON SUPPLY CHAIN MODEL

The sequence of events in any period at any echelon is as follows: the order placed earlier is received, and the demand is fulfilled at the beginning of the period, the inventory level is reviewed and ordering decision is made at the end of the period. We will now describe the three echelon supply chain model where each echelon uses

the OUT policy with the MMSE forecasting scheme. In this paper, we assume a periodic review period but do not assume a specific length of the review period. All of the results here are consistent whichever review period is adopted (day, week, month, *etc.*). Note that in the case of a single echelon supply chain, this OUT policy has been shown to be optimal by Johnson and Thompson [18] for a zero lead-time and linear inventory holding and stockout costs for the lost sales case. However, the optimal policy for a multi echelon supply chain is not yet well understood. We will use the subscript  $n$  ( $n = 1, 2, 3$ ) to represent the echelon level.

#### A. The Retailer's Ordering Policy ( $n = 1$ )

In an OUT policy,  $O_{t,1}$ , the order placed by the retailer at the end of time period  $t$ , can be expressed as;

$$O_{t,1} = D_t + (S_{t,1} - S_{t-1,1}), \quad (7)$$

$$S_{t,1} = \hat{D}_t^{l_1} + k_1 \hat{\sigma}_{l_1}^2. \quad (8)$$

$NS_{t,1}$ , the net inventory level of the retailer at the beginning of the period  $t$ , is given by

$$NS_{t,1} = NS_{t-1,1} + O_{t-l_1} - D_t.$$

It is well known that the MMSE forecast is provided by the conditional expectation [19, pp.133-135]. With an MMSE scheme,  $\hat{D}_t^{l_1}$  and  $\hat{\sigma}_{l_1}^2$  become;

$$\hat{D}_t^{l_1} = E\left(\sum_{i=1}^{l_1} D_{t+i} \mid \tau_t\right) = \frac{\rho(1-\rho^{l_1})}{1-\rho} D_t = \rho \Lambda_{l_1} D_t, \quad (9)$$

$$\begin{aligned} \hat{\sigma}_{l_1}^2 &= \text{Var}\left(\sum_{i=1}^{l_1} \hat{D}_{t+i} \mid \tau_t\right) = \sum_{j=1}^{l_1} \left\{ \sum_{i=0}^{j-1} \rho^i \right\}^2 \sigma_\varepsilon^2 \\ &= \frac{\sigma_\varepsilon^2}{(1-\rho)^2} \sum_{i=1}^{l_1} (1-\rho^i)^2 \end{aligned} \quad (10)$$

$$= \frac{\left( l_1(1-\rho^2) + \rho(1-\rho^{l_1})(\rho^{l_1+1} - \rho - 2) \right)}{(1-\rho)^2(1-\rho^2)} \sigma_\varepsilon^2, \quad (11)$$

where  $\Lambda_{l_1} = (1-\rho^{l_1})/(1-\rho)$ , and  $\tau_t = \{D_t, D_{t-1}, D_{t-2}, \dots\}$ , the set of all observed demand. Thus, from (7), (8), and (9), the retailer's order at time period  $t$  can be expressed as

$$O_{t,1} = D_t + \rho \Lambda_{l_1} (D_t - D_{t-1}). \quad (12)$$

Using (1) and (12), we have the retailer's order quantity for the period  $t + 1$ ,

$$O_{t+1,1} = \rho O_{t,1} + (1 + \rho \Lambda_{l_1}) \varepsilon_{t+1} - \rho \Lambda_{l_1} \varepsilon_t. \quad (13)$$

Note that (13) is a scaled ARMA(1,1) process which has been previously reported by [11], where the general expression is given by

$$O_{t+1,1} = \rho O_t + \varepsilon_{t+1} - \theta_1 \varepsilon_t.$$

Here  $\theta_1$  is the moving average (MA) parameter of the retailer's ordering process. Let us introduce an error term expressed as

$$\varepsilon_{t,1} = (1 + \rho\Lambda_{l_1})\varepsilon_t.$$

We may then rewrite (13) as

$$O_{t+1,1} = \rho O_{t,1} + \varepsilon_{t+1,1} - \frac{\rho\Lambda_{l_1}}{1 + \rho\Lambda_{l_1}}\varepsilon_{t,1}, \quad (14)$$

which represents an ARMA(1,1) process with  $\theta_1 = (\rho\Lambda_{l_1})/(1 + \rho\Lambda_{l_1})$ , and  $\Lambda_{l_1} = (1 - \rho^{l_1})/(1 - \rho)$ . (14) shows that the retailer's order contains all the information contained in the demand process, that is the values of  $\rho$  and  $\varepsilon_t$ . The general expression of variance of the ARMA(1,1) process is

$$\sigma_{\text{ARMA}(1,1)}^2 = \frac{1 + \theta^2 - 2\theta\rho}{1 - \rho^2} \sigma_\varepsilon^2,$$

where  $\theta$  is an MA parameter, and  $\sigma_\varepsilon^2$  is the variance of the error term. Appendix II details our control engineering methodology for calculating variance ratios. Appendix III applies it to the long-run variance of an ARMA(1,1) demand process.

### B. The Distributor's Ordering Policy ( $n = 2$ )

$O_{t,2}$ , the order placed by the distributor at the end of time period  $t$ , and  $NS_{t,2}$ , the net inventory level of the distributor at the beginning of the period  $t$  can be expressed as;

$$O_{t,2} = O_{t,1} + (S_{t,2} - S_{t-1,2}), \quad (15)$$

$$S_{t,2} = \hat{O}_{t,1}^{l_2} + k_2 \hat{\sigma}_{l_2}, \quad (16)$$

$$NS_{t,2} = NS_{t-1,2} + O_{t-l_2,2} - O_{t,1}.$$

Consider an MMSE forecasting scheme. We can express  $\hat{O}_{t,1}^{l_2}$  and  $\hat{\sigma}_{l_2}^2$  as;

$$\hat{O}_{t,1}^{l_2} = E\left(\sum_{i=1}^{l_2} O_{t+i,1} \mid \tau_{t,1}\right) = \Lambda_{l_2} \hat{O}_{t+1,1}, \quad (17)$$

$$\begin{aligned} \hat{\sigma}_{l_2}^2 &= \text{Var}\left(\sum_{i=1}^{l_2} \hat{O}_{t+i,1} \mid \tau_{t,1}\right) \\ &= \frac{\sigma_\varepsilon^2}{(1 - \rho)^2} \sum_{i=l_1+1}^{l_1+l_2} (1 - \rho^i)^2 \\ &= \frac{\left(l_2(1 - \rho^2) + \rho^{l_1+1}(1 - \rho^{l_2})(\rho^{l_1+1} + \rho^{l_1+l_2+1} - 2\rho - 2)\right)}{(1 - \rho)^2(1 - \rho^2)} \sigma_\varepsilon^2, \end{aligned} \quad (18)$$

where  $\Lambda_{l_2} = (1 - \rho^{l_2})/(1 - \rho)$ ,  $\hat{O}_{t+1,1} = E(O_{t+1,1} \mid O_{t,1}, \varepsilon_t) = \rho O_{t,1} - \rho\Lambda_{l_1}\varepsilon_t$ , and  $\tau_{t,1} = \{O_{t,1}, O_{t-1,1}, O_{t-2,1}, \dots\}$ , the set of all observed orders placed by the retailer. We can obtain from (15) - (17) the following expression for the distributor's ordering process,

$$O_{t,2} = O_{t,1} + \Lambda_{l_2}(\hat{O}_{t+1,1} - \hat{O}_{t,1}). \quad (20)$$

Now, we can find the distributor's order quantity for the period  $t + 1$  with (13) and (20),

$$\begin{aligned} O_{t+1,2} &= \rho O_{t,2} + (\rho \Lambda_{l_2} + \rho^2 \Lambda_{l_1} \Lambda_{l_2} - \rho \Lambda_{l_1} \Lambda_{l_2} + \rho \Lambda_{l_1} + 1) \varepsilon_{t+1} \\ &\quad - (\rho \Lambda_{l_2} + \rho^2 \Lambda_{l_1} \Lambda_{l_2} - \rho \Lambda_{l_1} \Lambda_{l_2} + \rho \Lambda_{l_1}) \varepsilon_t. \end{aligned} \quad (21)$$

(21) can be rewritten as

$$O_{t+1,2} = \rho O_{t,2} + \varepsilon_{t+1,2} - \frac{\rho \Lambda_{l_2} + \rho^2 \Lambda_{l_1} \Lambda_{l_2} - \rho \Lambda_{l_1} \Lambda_{l_2} + \rho \Lambda_{l_1}}{\rho \Lambda_{l_2} + \rho^2 \Lambda_{l_1} \Lambda_{l_2} - \rho \Lambda_{l_1} \Lambda_{l_2} + \rho \Lambda_{l_1} + 1} \varepsilon_{t,2}, \quad (22)$$

where

$$\varepsilon_{t,2} = (\rho \Lambda_{l_2} + \rho^2 \Lambda_{l_1} \Lambda_{l_2} - \rho \Lambda_{l_1} \Lambda_{l_2} + \rho \Lambda_{l_1} + 1) \varepsilon_t.$$

Interestingly, (22) is also an ARMA(1,1) process with

$$\theta_2 = \frac{\rho \Lambda_{l_2} + \rho^2 \Lambda_{l_1} \Lambda_{l_2} - \rho \Lambda_{l_1} \Lambda_{l_2} + \rho \Lambda_{l_1}}{\rho \Lambda_{l_2} + \rho^2 \Lambda_{l_1} \Lambda_{l_2} - \rho \Lambda_{l_1} \Lambda_{l_2} + \rho \Lambda_{l_1} + 1} = \frac{\mathcal{Y}}{\mathcal{X}}, \quad (23)$$

where  $\theta_2$  is MA parameter for the distributor's ordering process,  $\mathcal{X} = \rho \Lambda_{l_2} + \rho^2 \Lambda_{l_1} \Lambda_{l_2} - \rho \Lambda_{l_1} \Lambda_{l_2} + \rho \Lambda_{l_1} + 1$ , and  $\mathcal{Y} = \rho \Lambda_{l_2} + \rho^2 \Lambda_{l_1} \Lambda_{l_2} - \rho \Lambda_{l_1} \Lambda_{l_2} + \rho \Lambda_{l_1}$ .

### C. Manufacturer's Ordering Policy ( $n = 3$ )

The manufacturer's order and net inventory level at the end of time period  $t$ , are given by;

$$O_{t,3} = O_{t,2} + (S_{t,3} - S_{t-1,3}), \quad (24)$$

$$S_{t,3} = \hat{O}_{t,2}^{l_3} + k_3 \hat{\sigma}_{l_3}, \quad (25)$$

$$NS_{t,3} = NS_{t-1,3} + O_{t-1,3} - O_{t,2}.$$

We find  $\hat{O}_{t,2}^{l_3}$  and  $\hat{\sigma}_{l_3}^2$ , considering an MMSE forecasting scheme;

$$\hat{O}_{t,2}^{l_3} = E \left( \sum_{i=1}^{l_3} O_{t+i,2} \mid \tau_{t,2} \right) = \Lambda_{l_3} \hat{O}_{t+1,2}, \quad (26)$$

$$\begin{aligned} \hat{\sigma}_{l_3}^2 &= \text{Var} \left( \sum_{i=1}^{l_3} \hat{O}_{t+i,2} \mid \tau_{t,2} \right) \\ &= \frac{\sigma_{\varepsilon}^2}{(1-\rho)^2} \sum_{i=l_1+l_2+1}^{l_1+l_2+l_3} (1-\rho^i)^2 \end{aligned} \quad (27)$$

$$= \frac{\left( l_3 (1-\rho^2) + \frac{\rho^{l_1+l_2+1} (1-\rho^{l_3}) (\rho^{l_1+l_2+1} + \rho^{l_1+l_2+l_3+1} - 2\rho - 2)}{(1-\rho)^2 (1-\rho^2)} \right)}{(1-\rho)^2 (1-\rho^2)} \sigma_{\varepsilon}^2, \quad (28)$$

where  $\Lambda_{l_3} = (1-\rho^{l_3})/(1-\rho)$ ,  $\hat{O}_{t+1,2} = E(O_{t+1,2} \mid O_{t,2}, \varepsilon_t) = \rho O_{t,2} - \mathcal{Y} \varepsilon_t$ , and  $\tau_{t,2} = \{O_{t,2}, O_{t-1,2}, O_{t-2,2}, \dots\}$ , the set of all observed orders placed by the distributor.  $\mathcal{Y}$  is described in (23). Referring to (24) - (26), we find that  $O_{t,3}$  can be expressed as

$$O_{t,3} = O_{t,2} + \Lambda_{l_3} (\hat{O}_{t+1,2} - \hat{O}_{t,2}). \quad (29)$$



Substituting (21) into (29), we obtain the following,

$$O_{t+1,3} = \rho O_{t,3} + (\bar{\varepsilon} + \rho \Lambda_{l_3} \bar{\varepsilon} - \Lambda_{l_3} \gamma) \varepsilon_{t+1} - (\gamma + \rho \Lambda_{l_3} \bar{\varepsilon} - \Lambda_{l_3} \gamma) \varepsilon_t. \quad (30)$$

Incorporating

$$\varepsilon_{t,3} = (\bar{\varepsilon} + \rho \Lambda_{l_3} \bar{\varepsilon} - \Lambda_{l_3} \gamma) \varepsilon_t,$$

into (30), and after some simplification, we find that

$$O_{t+1,3} = \rho O_{t,3} + \varepsilon_{t+1,3} - \frac{\gamma + \rho \Lambda_{l_3} \bar{\varepsilon} - \Lambda_{l_3} \gamma}{\bar{\varepsilon} + \rho \Lambda_{l_3} \bar{\varepsilon} - \Lambda_{l_3} \gamma} \varepsilon_{t,3}. \quad (31)$$

Again, interestingly, we obtain an ARMA(1,1) ordering process (31) with an MA parameter of

$$\theta_3 = \frac{\gamma + \rho \Lambda_{l_3} \bar{\varepsilon} - \Lambda_{l_3} \gamma}{\bar{\varepsilon} + \rho \Lambda_{l_3} \bar{\varepsilon} - \Lambda_{l_3} \gamma}. \quad (32)$$

Applying (23), (32) can be rewritten as

$$\theta_3 = \frac{\theta_2 + \rho \Lambda_{l_3} - \Lambda_{l_3} \theta_2}{1 + \rho \Lambda_{l_3} - \Lambda_{l_3} \theta_2}.$$

We find that not only is the order process faced by distributor an ARMA(1,1) process, but also that the order process faced by the manufacturer follows an ARMA(1,1) process; furthermore both can be expressed in terms of the parameters of the market demand process. Therefore, the manufacturer will have, as the distributor does, complete information of the market demand process with the MMSE scheme. Fig. 2 summarises how the original AR(1) demand process is changed by the OUT policy with the MMSE scheme as it proceeds up the supply chain. Disney *et al.* [20] have observed that the ARMA(1,1) demand model matched real world demand patterns within the consumer goods industry. Within the OUT policy with the MMSE scheme, when an ARMA(1,1) process is assumed as the market demand process, we will observe that an ARMA(1,1) ordering process also occurs at the higher levels of the supply chain. Details are shown in Appendix IV. Thus the ARMA(1,1) process is, in a sense, “absorbing”.

## V. BULLWHIP IN A THREE ECHELON SUPPLY CHAIN

Let the variance amplification ratio (bullwhip) of orders ( $VR_{order}$ ) be given by;

$$\begin{aligned} VR_{order}[\text{Retail}] &= \frac{\sigma_{O_1}^2}{\sigma_D^2}, \\ VR_{order}[\text{Distri}] &= \frac{\sigma_{O_2}^2}{\sigma_D^2}, \\ VR_{order}[\text{Manu}] &= \frac{\sigma_{O_3}^2}{\sigma_D^2}, \end{aligned}$$

where  $\sigma_D^2$ ,  $\sigma_{O_1}^2$ ,  $\sigma_{O_2}^2$ , and  $\sigma_{O_3}^2$  are the variances of  $D_t$ ,  $O_{t,1}$ ,  $O_{t,2}$ , and  $O_{t,3}$  over an infinite time horizon respectively. Each variance can be described as;

$$\sigma_D^2 = \frac{\sigma_\varepsilon^2}{1 - \rho^2}, \quad (33)$$

$$\sigma_{O_1}^2 = \frac{\left( (1 - \rho^{l_1+1})^2 + \rho^2 (1 - \rho^{l_1})^2 - 2\rho^2 (1 - \rho^{l_1+1})(1 - \rho^{l_1}) \right)}{(1 - \rho)^2(1 - \rho^2)} \sigma_\varepsilon^2, \quad (34)$$

$$\sigma_{O_2}^2 = \frac{\left( (1 - \rho^{l_1+l_2+1})^2 + \rho^2 (1 - \rho^{l_1+l_2})^2 - 2\rho^2 (1 - \rho^{l_1+l_2+1})(1 - \rho^{l_1+l_2}) \right)}{(1 - \rho)^2(1 - \rho^2)} \sigma_\varepsilon^2, \quad (35)$$

$$\sigma_{O_3}^2 = \frac{\left( (1 - \rho^{l_1+l_2+l_3+1})^2 + \rho^2 (1 - \rho^{l_1+l_2+l_3})^2 - 2\rho^2 (1 - \rho^{l_1+l_2+l_3+1})(1 - \rho^{l_1+l_2+l_3}) \right)}{(1 - \rho)^2(1 - \rho^2)} \sigma_\varepsilon^2. \quad (36)$$

(34) - (36) reveal that when  $l_1 + l_2$  or  $l_1 + l_2 + l_3$  is constant, the value of the  $\sigma_{O_2}^2$  or  $\sigma_{O_3}^2$  keeps its original value. Thus, the following insight is revealed.

*Insight 1:* When each participant in supply chain uses the OUT policy with the MMSE forecasting scheme, it is the sum of the accumulation of all downstream replenishment lead-times (or the echelon lead-time) and the local replenishment lead-time that influences the variance of order rates in a supply chain and not the number of echelons.

*Proof:* For convenience, let us use  $L_e$ , where  $L_e$  represents the sum of the accumulation of all downstream lead-times and the local replenishment lead-time in a supply chain. We will then have a general expression for the variance of order,

$$\frac{\left( (1 - \rho^{L_e+1})^2 + \rho^2 (1 - \rho^{L_e})^2 - 2\rho^2 (1 - \rho^{L_e+1})(1 - \rho^{L_e}) \right)}{(1 - \rho)^2(1 - \rho^2)} \sigma_\varepsilon^2,$$

which has no information on the number of echelons in a supply chain. ■

Combining the variance expressions surrenders the variance ratio of order;

$$\begin{aligned} VR_{order}[\text{Retail}] &= 1 + \frac{2\rho(1 - \rho^{l_1})(1 - \rho^{l_1+1})}{1 - \rho}, \\ VR_{order}[\text{Distri}] &= \frac{\left( (1 - \rho^{l_1+l_2+1})^2 + \rho^2 (1 - \rho^{l_1+l_2})^2 - 2\rho^2 (1 - \rho^{l_1+l_2+1})(1 - \rho^{l_1+l_2}) \right)}{(1 - \rho)^2}, \\ VR_{order}[\text{Manu}] &= \frac{\left( (1 - \rho^{l_1+l_2+l_3+1})^2 + \rho^2 (1 - \rho^{l_1+l_2+l_3})^2 - 2\rho^2 (1 - \rho^{l_1+l_2+l_3+1})(1 - \rho^{l_1+l_2+l_3}) \right)}{(1 - \rho)^2}. \end{aligned}$$

We have plotted  $VR_{order}$  under the condition that  $-1 < \rho < 1$  with four patterns of lead-time settings constrained to  $l_1 + l_2 + l_3 = 15$  in Fig. 3. From this figure, we will find that:

- bullwhip effect does not occur when  $\rho \leq 0$ . The proof is provided in Appendix V.

In the case of  $\rho > 0$ , we can see that:

- The  $VR_{order}$  are almost identical when  $\rho$  is relatively small (e.g.  $\rho < |0.2|$ ).
- $VR_{order}[\text{Manu}]$  is not affected by the values of  $l_1$ ,  $l_2$ , or  $l_3$ . As we expect, it keeps the same shape under the constraint that  $l_1 + l_2 + l_3$  is constant.
- The condition  $VR_{order}[\text{Retail}] \leq VR_{order}[\text{Distri}] \leq VR_{order}[\text{Manu}]$  is observed for all lead-time settings.

## VI. THE NET INVENTORY VARIANCE AMPLIFICATION RATIO IN A THREE ECHELON SUPPLY CHAIN

From our description in Section II and IV, we may now develop a block diagram of the three echelon supply chain with the MMSE forecasting. The block diagram is shown in Fig. 8. The transfer function of the net inventory levels can be found from this block diagram and from this we may derive the variance of the net inventory levels;

$$\sigma_{NS_1}^2 = \frac{\left( l_1 (1 - \rho^2) + \rho (1 - \rho^{l_1}) (\rho^{l_1+1} - \rho - 2) \right)}{(1 - \rho)^2 (1 - \rho^2)} \sigma_\varepsilon^2, \quad (37)$$

$$\sigma_{NS_2}^2 = \frac{\left( l_2 (1 - \rho^2) + \rho^{l_1+1} (1 - \rho^{l_2}) (\rho^{l_1+1} + \rho^{l_1+l_2+1} - 2\rho - 2) \right)}{(1 - \rho)^2 (1 - \rho^2)} \sigma_\varepsilon^2, \quad (38)$$

$$\sigma_{NS_3}^2 = \frac{\left( l_3 (1 - \rho^2) + \rho^{l_1+l_2+1} (1 - \rho^{l_3}) (\rho^{l_1+l_2+1} + \rho^{l_1+l_2+l_3+1} - 2\rho - 2) \right)}{(1 - \rho)^2 (1 - \rho^2)} \sigma_\varepsilon^2. \quad (39)$$

where  $\sigma_{NS_1}^2$ ,  $\sigma_{NS_2}^2$ , and  $\sigma_{NS_3}^2$ , are the variance of the net inventory levels at the retailer, the distributor, and the manufacturer, respectively. Comparing (37) - (39) to (11), (19), and (28), we can recognise that the net inventory variance is identical to the variance of forecast error over the lead-time, as we expect. Here, we have the following two insights:

*Insight 2:* When each participant uses the OUT policy with the MMSE forecasting scheme, it is the local replenishment lead-time that dominates the variance of the net inventory levels and not the accumulation of the downstream replenishment lead-time, if the value of  $\rho$  is close to zero, and/or at least one of  $\{L_{down} + 1, L_{down} + l_{local}\}$  is large enough.

*Proof:* As an expression of the variance of the net inventory levels, we can use (10), (18), and (27) instead of (37), (38), and (39) because the variance of net inventory is equal to the variance of forecast error over the lead-time. For convenience, we use  $L_{down}$  and  $l_{local}$  to represent the accumulation of the downstream replenishment lead-times and the local replenishment lead-time, respectively. Note that  $L_{down} = 0$  for the

first echelon. This will yield a new general expression for the variance of the net inventory level,

$$\frac{\sigma_{\varepsilon}^2}{(1-\rho)^2} \sum_{i=L_{down}+1}^{L_{down}+l_{local}} (1-\rho^i)^2.$$

And this can be rewritten as

$$\sigma_{\varepsilon}^2 \sum_{i=L_{down}+1}^{L_{down}+l_{local}} \left( \frac{1-\rho^i}{1-\rho} \right)^2.$$

Here, the value of  $\sigma_{\varepsilon}^2$  is constant. Since  $|\rho| < 1$  is assumed, we have

$$\lim_{i \rightarrow \infty} \left( \frac{1-\rho^i}{1-\rho} \right)^2 = \left( \frac{1}{1-\rho} \right)^2.$$

Now, if we exploit this relationship, we have the approximation of the variance of the net inventory levels,

$$\sigma_{\varepsilon}^2 \sum_{i=L_{down}+1}^{L_{down}+l_{local}} \left( \frac{1-\rho^i}{1-\rho} \right)^2 \approx \sigma_{\varepsilon}^2 \left( \frac{1}{1-\rho} \right)^2 \times l_{local}. \quad (40)$$

This is the case that the  $l_{local}$  has a dominant impact on the the variance of net inventory levels. This relationship (40) is valid if:

- 1) the value of  $\rho$  is close to zero, regardless of the value of  $L_{down}$  or  $l_{local}$ , and/or
- 2) at least one of  $\{L_{down} + 1, L_{down} + l_{local}\}$  is large enough, regardless of the value of  $\rho$ .

■

The second condition is not critical as it may be seen in terms of the dominance of  $l_{local}$ . Fig. 4 shows the distributor's variances of the net inventory levels in the cases that case 1:  $l_{local} = 1$  and case 2:  $l_{local} = 2$  under the constraint  $L_{down} + l_{local} = 3$ . Even when the total replenishment lead-times for each case are equal and small, the dominance of  $l_{local}$  is clearly shown in Fig. 4; the variance of net inventory levels for case 1 is always bigger than that for case 2; at any value of  $\rho$ .

*Insight 3:* When each participant uses the OUT policy with the MMSE forecasting scheme, the variance of the total net inventory,  $\sigma_{NS_1}^2 + \sigma_{NS_2}^2 + \sigma_{NS_3}^2$ , can be expressed as the variance of forecast error over the accumulated replenishment lead-time and is independent from the number of echelons to the end consumer.

*Proof:* Again, we will use (10), (18), and (27). The sum of the variance of the net inventory level in the supply chain can be obtained as;

$$\begin{aligned} \sigma_{NS_1}^2 + \sigma_{NS_2}^2 + \sigma_{NS_3}^2 &= \\ &= \frac{\sigma_{\varepsilon}^2}{(1-\rho)^2} \left( \sum_{i=1}^{l_1} (1-\rho^i)^2 + \sum_{i=l_1+1}^{l_1+l_2} (1-\rho^i)^2 + \sum_{i=l_1+l_2+1}^{l_1+l_2+l_3} (1-\rho^i)^2 \right) \\ &= \frac{\sigma_{\varepsilon}^2}{(1-\rho)^2} \sum_{i=1}^{l_1+l_2+l_3} (1-\rho^i)^2 \\ &= \frac{\sigma_{\varepsilon}^2}{(1-\rho)^2} \sum_{i=1}^{L_e} (1-\rho^i)^2. \end{aligned} \quad (41)$$

where  $L_e = l_1 + l_2 + l_3$ . (41) does not contain information on the number of echelons any more, but does contain information on the accumulated replenishment lead-time in the supply chain. ■

We now obtain the net inventory variance amplification ratio ( $VR_{inv}$ ), which is given by;

$$VR_{inv}[\text{Retail}] = \frac{\sigma_{NS_1}^2}{\sigma_D^2},$$

$$VR_{inv}[\text{Distri}] = \frac{\sigma_{NS_2}^2}{\sigma_D^2},$$

$$VR_{inv}[\text{Manu}] = \frac{\sigma_{NS_3}^2}{\sigma_D^2}.$$

Using the results in this section,  $VR_{inv}$  is expressed as;

$$VR_{inv}[\text{Retail}] = \frac{\left( l_1(1 - \rho^2) + \rho(1 - \rho^{l_1})(\rho^{l_1+1} - \rho - 2) \right)}{(1 - \rho)^2}, \quad (42)$$

$$VR_{inv}[\text{Distri}] = \frac{\left( l_2(1 - \rho^2) + \rho^{l_1+1}(1 - \rho^{l_2})(\rho^{l_1+1} + \rho^{l_1+l_2+1} - 2\rho - 2) \right)}{(1 - \rho)^2}, \quad (43)$$

$$VR_{inv}[\text{Manu}] = \frac{\left( l_3(1 - \rho^2) + \rho^{l_1+l_2+1}(1 - \rho^{l_3})(\rho^{l_1+l_2+1} + \rho^{l_1+l_2+l_3+1} - 2\rho - 2) \right)}{(1 - \rho)^2}. \quad (44)$$

We have plotted  $VR_{inv}$  under the condition that  $-1 < \rho < 1$ , with four patterns of lead-time settings, constrained to  $l_1 + l_2 + l_3 = 15$  in Fig. 5. From this figure, we will find that:

- The net inventory variance is also affected by the value of  $\rho$ .
- Even when  $\rho$  is negative, we will find that the net inventory may still vary more than demand.
- In contrast to  $VR_{order}$ , the affect of the local lead-time can be clearly seen. In the case of  $l_1 = 12$ , even though the retailer takes the closest position to the market, the net inventory variance is bigger than the distributor's and the manufacturer's net inventory variance. Furthermore, the level of supply chain has less impact on  $VR_{inv}$ , as we expect from *Insight 2*.

## VII. CONCLUSION

We have investigated a three echelon supply chain, constituting of a retailer, a distributor, and a manufacturer, using a combination of statistical methods and control theory. We assume the demand process follows an AR(1) stationary process and each supply chain participant adopts the OUT policy with the MMSE forecasting scheme.

The OUT policy minimises the variance of the net inventory levels with a given forecasting method and that the minimised variance of the net inventory levels is equal to the variance of the forecast error over the lead-time. This interesting characteristic can be applied to an evaluation of inventory performance in the real business. Simple comparison of the variance of net inventory levels and the variance of forecast error over the lead-time yields useful insights on the inventory performance. For example, if the variance of net inventory levels is greater than that of the forecast error over the lead-time, there might be room to improve inventory turn over. However, if both values

of variances are (nearly) equal, inventory management is under control and one way to improve your inventory turn over is to increase the forecast accuracy.

The AR(1) demand process is transformed into an ARMA(1,1) process as it moves up supply chain. The autoregressive parameter keeps its original value, although the moving average parameter is changed at every each echelon. The value of the moving average parameter is a function of the autoregressive parameter, the accumulated downstream lead-time, and the local replenishment lead-time for the echelon in question.

As the ordering process contains complete information of market demand, the upstream supply chain participants may exploit an ARMA(1,1) model to estimate both the autoregressive and the moving average parameters to create the MMSE forecasts. Then, with knowledge of the accumulated lead-time and the demand process, each participant may estimate the quantity of its demand over the lead-time. Thus, with the set of assumptions in this paper, and as suggested in Raghunathan [10], there is no benefit of information sharing in terms of the forecast accuracy among supply chain participants. This result leads us to a practical insight. Before thinking about information sharing with your downstream customer, it might be better to identify the demand process you face and the ordering policy the customer uses. If the demand process follows ARMA(1,1), and your customer employs the OUT policy with the MMSE forecasting method, you might already have full information of the demand in the market place.

To describe the character of a three echelon supply chain, we used two measurement methods;  $VR_{order}$ , and  $VR_{inv}$ . In terms of  $VR_{order}$ , the number of stages in the supply chain does not affect the value of  $VR_{order}$ . Only the accumulated lead-time has an impact upon  $VR_{order}$ . Also, we find that the local lead-time has the dominant impact on the variance of the net inventory levels, if the value of  $\rho$  is close to zero, and/or at least one of  $\{L_{down} + 1, L_{down} + l_{local}\}$  is large enough. Therefore, reducing a local lead-time will allow all upstream suppliers to reduce their local order related costs, but it will also have a large positive effect on local inventory holding costs. Via simulation, we have shown that  $VR_{inv}[\text{Retail}]$  may be greater than  $VR_{inv}[\text{Manu}]$ , even when  $VR_{order}[\text{Retail}]$  is smaller than  $VR_{order}[\text{Manu}]$ .

Finally, we have also extended Vassian's [16] finding that the conditional variance of forecast error over the lead-time is identical to the variance of the net inventory levels to a multi echelon supply chain setting. We have shown that the variance of the *total* net inventory levels can be expressed as the variance of forecast error over the accumulated replenishment lead-time. To estimate the variance of the total net inventory level, it is sufficient to conduct an analysis of a single echelon model with the accumulated replenishment lead-time ( $L_e$ ), instead of a multi echelon model, and calculate the variance of the net inventory levels or the forecast error over the lead-time.

## APPENDIX I

### ANALYSIS OF OUR ORDERING POLICY MODEL

First, we consider the case that lead-time is greater than one. Without loss of generality, we assume  $k = 0$ , thus  $S_t = \hat{D}_t'$ . Using (4),  $O_t$  can be written as

$$O_t = NS_{t+l} - NS_{t+l-1} + D_{t+l}. \quad (45)$$

Substituting the above equation into (3), we will have another expression of  $WIP_t$ ,

$$WIP_t = NS_{t+l-1} - NS_t + \sum_{i=1}^{l-1} D_{t+i}. \quad (46)$$

Then, (2) can be rewritten as;

$$\begin{aligned} O_t &= \hat{D}_t^l - WIP_t - NS_t \\ &= S_t - \left( NS_{t+l-1} - NS_t + \sum_{i=1}^{l-1} D_{t+i} \right) - NS_t \\ &= S_t - \left( NS_{t+l-1} + \sum_{i=1}^{l-1} D_{t+i} \right). \end{aligned}$$

By using (2), (45), and (46), the second expression on the right hand side of the above equation can be written as

$$NS_{t+l-1} = \hat{D}_{t-1}^l - \sum_{i=1}^l D_{t-1+i}.$$

This yields the required expression for  $O_t$ ;

$$\begin{aligned} O_t &= \hat{D}_t^l - WIP_t - NS_t \\ &= S_t - \left( NS_{t+l-1} + \sum_{i=1}^{l-1} D_{t+i} \right) \\ &= S_t - \left( \hat{D}_{t-1}^l - \sum_{i=1}^l D_{t-1+i} + \sum_{i=1}^{l-1} D_{t+i} \right) \\ &= \left( \sum_{i=1}^l D_{t-1+i} - \sum_{i=1}^{l-1} D_{t+i} \right) + S_t - \hat{D}_{t-1}^l \\ &= D_t + (S_t - S_{t-1}), \end{aligned}$$

which is identical to (5). To obtain the last equation, we use  $\sum_{i=1}^l D_{t-1+i} - \sum_{i=1}^{l-1} D_{t+i} = D_t$ . Following the same steps as above, yields the same conclusion for the case of unit lead-time where  $WIP_t = 0$ .

## APPENDIX II

### ARRIVING AT VARIANCE EXPRESSIONS WITH CONTROL THEORY

From a verbal description it is easy to develop block diagrams that represent a supply chain in z-transform notation. We refer readers to Nise [21] for an introduction to block diagrams.

The block diagram may be manipulated with simple techniques to yield transfer functions. From the transfer function the required expressions for the variance amplification ratios may be determined using Cauchy's contour integral, see (47), where  $F(z)$  is the transfer function relating the input to the output of the system [22].

$$VR = \frac{\sigma_{Output}^2}{\sigma_{Input}^2} = \frac{1}{2\pi\sqrt{-1}} \oint F(z)F(z^{-1})z^{-1} dz. \quad (47)$$

The contour integral may be evaluated easily using a technique due to Åström *et al.* [23] that was further refined by Jury [22]. Let us present the approach of Jury to derive our variance expressions. We refer readers to Jury [22] for any required proof of his approach. Let the following form,

$$F(z) = \frac{B(z)}{A(z)} = \frac{\sum_{i=0}^n b_i z^i}{\sum_{i=0}^n a_i z^i},$$

describe the transfer function relating input to output of the variance ratio we require. The coefficients  $a_i$  and  $b_i$  obviously depend on the transfer function in question. Next construct 2 matrices,  $\mathbf{X}_{n+1}$  and  $\mathbf{Y}_{n+1}$  of the coefficients of  $A(z)$  as follows;

$$\mathbf{X}_{n+1} = \begin{bmatrix} a_n & a_{n-1} & a_{n-2} & \dots & a_0 \\ 0 & a_n & a_{n-1} & \dots & a_1 \\ 0 & 0 & a_n & \dots & a_2 \\ \vdots & \vdots & \vdots & \vdots & \vdots \\ 0 & 0 & 0 & 0 & a_n \end{bmatrix}, \mathbf{Y}_{n+1} = \begin{bmatrix} 0 & 0 & \dots & 0 & a_0 \\ 0 & \dots & & & \vdots \\ \vdots & 0 & a_0 & \dots & a_{n-2} \\ 0 & a_0 & a_1 & \dots & a_{n-1} \\ a_0 & a_1 & a_2 & \dots & a_n \end{bmatrix}.$$

Jury shows that the variance ratio is given by

$$VR = \frac{|\mathbf{X}_{n+1} + \mathbf{Y}_{n+1} \mathbf{b}|}{a_n |\mathbf{X}_{n+1} + \mathbf{Y}_{n+1}|},$$

where  $[\mathbf{X}_{n+1} + \mathbf{Y}_{n+1}] \mathbf{b} = [\mathbf{X}_{n+1} + \mathbf{Y}_{n+1}]$  with the last row replaced by  $[2b_n b_0, 2 \sum b_i b_{i+n-1}, \dots, 2 \sum b_i b_{i+1}, 2 \sum_{i=0}^n b_i^2]$ .

Thus, a simple algebraic process will construct a variance ratio expression.

### APPENDIX III

#### DERIVING THE VARIANCE RATIO EXPRESSIONS

By way of introduction, let us first consider the simple case of calculating the variance of the AR(1) demand. It is easy to see from (1) that the block diagram of the AR(1) process is as shown in Fig. 6.

Without loss of generality, we assume  $d = 0$ . Rearranging the block diagram we arrive at the following transfer function,

$$\frac{D(z)}{\varepsilon(z)} = \frac{1}{1 - \rho z^{-1}}.$$

This transfer function has the following constant coefficients;

$$b_0 = 0, \quad a_0 = -\rho.$$

and

$$b_1 = 1, \quad a_1 = 1.$$



Arranging these coefficients into the  $\mathbf{X}_{n+1}$  and  $\mathbf{Y}_{n+1}$  matrices yields;

$$\mathbf{X}_{n+1} = \begin{bmatrix} a_1 & a_0 \\ 0 & a_1 \end{bmatrix} = \begin{bmatrix} 1 & -\rho \\ 0 & 1 \end{bmatrix},$$

$$\mathbf{Y}_{n+1} = \begin{bmatrix} 0 & a_0 \\ a_0 & a_1 \end{bmatrix} = \begin{bmatrix} 0 & -\rho \\ -\rho & 1 \end{bmatrix}.$$

Thus the  $[\mathbf{X}_{n+1} + \mathbf{Y}_{n+1}]$  and  $[\mathbf{X}_{n+1} + \mathbf{Y}_{n+1}]_{\mathbf{b}}$  matrices are;

$$[\mathbf{X}_{n+1} + \mathbf{Y}_{n+1}] = \begin{bmatrix} 1 & -2\rho \\ -\rho & 2 \end{bmatrix},$$

$$[\mathbf{X}_{n+1} + \mathbf{Y}_{n+1}]_{\mathbf{b}} = \begin{bmatrix} 1 & -2\rho \\ 2b_0b_1 & 2(b_0^2 + b_1^2) \end{bmatrix} = \begin{bmatrix} 1 & -2\rho \\ 0 & 2 \end{bmatrix}.$$

The determinants of these two matrices are;

$$|\mathbf{X}_{n+1} + \mathbf{Y}_{n+1}| = 2(1 - \rho^2),$$

$$|\mathbf{X}_{n+1} + \mathbf{Y}_{n+1}|_{\mathbf{b}} = 2.$$

Assuming that the variance of the random shock is unity, we may determine the variance of the AR(1) demand as;

$$\sigma_{\text{AR}(1)}^2 = \frac{|\mathbf{X}_{n+1} + \mathbf{Y}_{n+1}|_{\mathbf{b}}}{a_1 |\mathbf{X}_{n+1} + \mathbf{Y}_{n+1}|} = \frac{2}{2(1 - \rho^2)} = \frac{1}{1 - \rho^2}.$$

The ARMA(1,1) demand pattern is also very easy to determine using the same approach. Let us illustrate our procedure once more. The block diagram is shown in Fig.7. The transfer function of  $D_t$  is given by

$$\frac{D(z)}{\varepsilon(z)} = \frac{z - \theta}{z - \rho}.$$

Then we can see the following constant coefficients;

$$b_0 = -\theta, \quad a_0 = -\rho.$$

and

$$b_1 = 1, \quad a_1 = 1.$$

Arranging these coefficients into the  $\mathbf{X}_{n+1}$  and  $\mathbf{Y}_{n+1}$  matrices yields;

$$\mathbf{X}_{n+1} = \begin{bmatrix} a_1 & a_0 \\ 0 & a_1 \end{bmatrix} = \begin{bmatrix} 1 & -\rho \\ 0 & 1 \end{bmatrix},$$

$$\mathbf{Y}_{n+1} = \begin{bmatrix} 0 & a_0 \\ a_0 & a_1 \end{bmatrix} = \begin{bmatrix} 0 & -\rho \\ -\rho & 1 \end{bmatrix}.$$

Thus the  $[\mathbf{X}_{n+1} + \mathbf{Y}_{n+1}]$  and  $[\mathbf{X}_{n+1} + \mathbf{Y}_{n+1}]_{\mathbf{b}}$  matrices are;

$$[\mathbf{X}_{n+1} + \mathbf{Y}_{n+1}] = \begin{bmatrix} 1 & -2\rho \\ -\rho & 2 \end{bmatrix},$$

$$[\mathbf{X}_{n+1} + \mathbf{Y}_{n+1}]_{\mathbf{b}} = \begin{bmatrix} 1 & -2\rho \\ 2b_0b_1 & 2(b_0^2 + b_1^2) \end{bmatrix} = \begin{bmatrix} 1 & -2\rho \\ -2\theta & 2(\theta^2 + 1) \end{bmatrix}.$$

The determinants of these two matrices are;

$$|\mathbf{X}_{n+1} + \mathbf{Y}_{n+1}| = 2(1 - \rho^2),$$

$$|\mathbf{X}_{n+1} + \mathbf{Y}_{n+1}|_{\mathbf{b}} = 2(\theta^2 + 1) - 4\theta\rho.$$

Assuming that the variance of the random shock is unity, we may determine the variance of the ARMA(1,1) demand as;

$$\sigma_{\text{ARMA}(1,1)}^2 = \frac{|\mathbf{X}_{n+1} + \mathbf{Y}_{n+1}|_{\mathbf{b}}}{a_1 |\mathbf{X}_{n+1} + \mathbf{Y}_{n+1}|} = \frac{2(1 + \theta^2 - 2\theta\rho)}{2(1 - \rho^2)} = \frac{1 + \theta^2 - 2\theta\rho}{1 - \rho^2}.$$

Now let us turn our attention to the three echelon supply chain model. It is easy to develop the following block diagram (Fig. 8) of our supply chain. From Fig. 8 we may identify the system transfer functions that relate the net inventory levels and order rates at each echelon of the supply chain to the white noise process. Here, we provide the transfer functions of the retailer's order process and the net inventory level;

$$\frac{O_1(z)}{\varepsilon(z)} = \frac{\rho - z + (z - 1)\rho^{l_1+1}}{(z - \rho)(\rho - 1)},$$

$$\frac{NS_1(z)}{\varepsilon(z)} = \frac{z^{1-l_1}(-z(1 + z^{l_1}(\rho - 1)) + \rho + (z - 1)\rho^{l_1+1})}{(z - 1)(z - \rho)(\rho - 1)}.$$

From these transfer functions we may use Jury's Inners approach to determine the variance ratios (Note that we also have to divide this by the variance of the demand). We have omitted these results here as there are rather lengthy, although they are available upon request for interested readers.

Interestingly, we note that an alternative block diagram (Fig. 9) may be derived that is dynamically equivalent to Fig. 8. From here it is obvious that there is no value of information sharing in this traditional supply chain, as market place information is clearly, already shared and exploited in this model.

#### APPENDIX IV

##### DERIVATION OF RETAILER'S ORDERING PROCESS WITH ARMA(1,1) DEMAND PROCESS

ARMA(1,1) demand process can be expressed as

$$D_{t+1} = \rho D_t + \varepsilon_{t+1} - \theta \varepsilon_t, \quad (48)$$

where  $\rho$  is AR parameter,  $\theta$  is MA parameter, and  $\varepsilon_t$  is a i.i.d. white noise process with mean zero and variance  $\sigma_\varepsilon^2$  at time period  $t$ . With the MMSE forecasting scheme,  $\hat{D}_t^{l_1}$  becomes;

$$\hat{D}_t^{l_1} = E\left(\sum_{i=1}^{l_1} D_{t+i} \mid \tau_t\right) = \frac{(1 - \rho^{l_1})}{1 - \rho} \hat{D}_{t+1} = \Lambda_{l_1} \hat{D}_{t+1}, \quad (49)$$

where  $\Lambda_{l_1} = (1 - \rho^{l_1})/(1 - \rho)$ ,  $\hat{D}_{t+1} = \rho D_t - \theta \varepsilon_t$ , and  $\tau_t = \{D_t, D_{t-1}, D_{t-2}, \dots\}$ .  $\tau_t$  is the set of all observed demands. Thus, from (7), (8), and (49), the retailer's order at time period  $t$  is expressed as

$$O_{t,1} = D_t + \Lambda_{l_1}(\hat{D}_{t+1} - \hat{D}_t). \quad (50)$$

Incorporating (48) into (50), we have the retailer's order quantity for period  $t + 1$

$$O_{t+1,1} = \rho O_{t,1} + (1 + \Lambda_{l_1}\rho - \Lambda_{l_1}\theta)\varepsilon_{t+1} - (\theta + \Lambda_{l_1}\rho - \Lambda_{l_1}\theta)\varepsilon_t. \quad (51)$$

If we introduce an error term which is expressed as

$$\varepsilon_{t,1} = (1 + \Lambda_{l_1}\rho - \Lambda_{l_1}\theta)\varepsilon_t,$$

then we may rewrite (51) as

$$O_{t+1,1} = \rho O_{t,1} + \varepsilon_{t+1,1} - \frac{\theta + \Lambda_{l_1}\rho - \Lambda_{l_1}\theta}{1 + \Lambda_{l_1}\rho - \Lambda_{l_1}\theta} \varepsilon_{t,1},$$

which represents a scaled ARMA(1,1) process with the converted new MA parameter

$$\frac{\theta + \Lambda_{l_1}\rho - \Lambda_{l_1}\theta}{1 + \Lambda_{l_1}\rho - \Lambda_{l_1}\theta}.$$

#### APPENDIX V

##### BULLWHIP DOES NOT OCCUR IF $-1 < \rho \leq 0$

Let  $L_e$  represent the accumulated replenishment lead-time. Thus, the expression of the variance ratio of order will be

$$VR_{order} = \frac{\left( (1 - \rho^{L_e+1})^2 + \rho^2 (1 - \rho^{L_e})^2 - 2\rho^2 (1 - \rho^{L_e+1})(1 - \rho^{L_e}) \right)}{(1 - \rho)^2}.$$

After some algebraic simplification, we have

$$VR_{order} = 1 + \frac{2\rho}{(1 - \rho)^2} (-\rho^{2L_e+2} + \rho^{2L_e+1} + \rho^{L_e+2} - \rho^{L_e} - \rho + 1).$$

To show the bullwhip will not occur, it is enough to describe that the second term of the above equation is negative, which will make the  $VR_{order} \leq 1$ . However, since  $-1 < \rho \leq 0$  and  $\frac{2\rho}{(1-\rho)^2} \leq 0$ , it is sufficient to show that;

$$-\rho^{2L_e+2} + \rho^{2L_e+1} + \rho^{L_e+2} - \rho^{L_e} - \rho + 1 \geq 0. \quad (52)$$

Case 1:  $L_e$  is even.

Since  $-1 < \rho \leq 0$  and  $L_e$  is positive integer, we can see that

$$\begin{aligned} \rho^{L_e+2} - \rho^{2L_e+2} &\geq 0, \\ -\rho^{L_e} - \rho &\geq 0, \\ \rho^{2L_e+1} + 1 &\geq 0. \end{aligned}$$

Thus, the sum of the all left hand expressions in (52) is positive.

Case 2:  $L_e$  is odd.

Similarly, but with a little modification, we will have;

$$\begin{aligned}\rho^{L_e+2} - \rho &\geq 0, \\ -\rho^{2L_e+2} - \rho^{L_e} &\geq 0, \\ \rho^{2L_e+1} + 1 &\geq 0.\end{aligned}$$

Again, the sum of the all left hand expressions of (52) is positive.

#### REFERENCES

- [1] J. Forrester, *Industrial Dynamics*. Cambridge, MA: MIT Press, 1961.
- [2] Y. F. Chen, Z. Drezner, J. K. Ryan, and D. Simchi-Levi, "Quantifying the bullwhip effect in a simple supply chain: The impact of forecasting, lead times, and information," *Management Science*, vol. 46, no. 3, pp. 436–443, 2000.
- [3] L. C. Alwan, J. J. Liu, and D. Yao, "Stochastic characterization of upstream demand process in a supply chain," *IIR Transactions*, vol. 35, pp. 207–219, 2003.
- [4] J. Dejonckheere, S. M. Disney, M. R. Lambrecht, and D. R. Towill, "The impact of information enrichment on the bullwhip effect in supply chains: A control engineering perspective," *European Journal of Operational Research*, vol. 153, pp. 727–750, 2004.
- [5] X. Zhang, "The impact of forecasting methods on the bullwhip effect," *International Journal of Production Economics*, vol. 88, pp. 15–27, 2004.
- [6] S. M. Disney and D. R. Towill, "On the bullwhip and inventory variance produced by an ordering policy," *OMEGA, International Journal of Management Science*, vol. 31, pp. 157–167, 2003.
- [7] H. L. Lee, K. C. So, and C. S. Tang, "The value of information sharing in a two-level supply chain," *Management Science*, vol. 46, no. 5, pp. 626–643, 2000.
- [8] K. Xu, Y. Dong, and P. T. Evers, "Towards better coordination of the supply chain," *Transportation Research Part E*, vol. 37, no. 1, pp. 35–54, 2001.
- [9] H. Kim and J. K. Ryan, "The cost impact of using simple forecasting techniques in a supply chain," *Naval Research Logistics*, vol. 50, pp. 388–411, 2003.
- [10] S. Raghunathan, "Information sharing in a supply chain: A note on its value when demand is nonstationary," *Management Science*, vol. 47, no. 4, pp. 605–610, 2001.
- [11] K. Gilbert, "An ARIMA supply chain model." Working paper, Management Science Program, University of Tennessee: Available[Online] <http://bus.utk.edu/mgmtsci/oldsite/gilbert/>, 2002.
- [12] Y. F. Chen, J. K. Ryan, and D. Simchi-Levi, "The impact of exponential smoothing forecasts on the bullwhip effect," *Naval Research Logistics*, vol. 47, pp. 269–286, 2000.
- [13] J. A. Kahn, "Inventories and the volatility of production," *American Economic Review*, vol. 77, pp. 667–679, 1987.
- [14] H. L. Lee, V. Padmanabhan, and S. Whang, "Information distortion in a supply chain: The bullwhip effect," *Management Science*, vol. 43, no. 4, pp. 546–558, 1997.
- [15] Y. Aviv, "Gaining benefits from joint forecasting and replenishment processes: The case of auto-correlated demand," *Manufacturing & Service Operations Management*, vol. 4, no. 1, pp. 55–74, 2002.
- [16] H. J. Vassian, "Application of discrete variable servo theory to inventory control," *Journal of the Operations Research Society of America*, vol. 3, no. 3, pp. 272–282, 1955.
- [17] T. Hosoda and S. M. Disney, "The role of an ordering policy as an inventory and cost controller." In proceedings of Logistics Research Network Annual Conference, Dublin, Ireland, 2004, pp. 268–275.

- [18] G. D. Johnson and H. E. Thompson, "Optimality of myopic inventory policies for certain dependent demand processes," *Management Science*, vol. 21, no. 11, pp. 1303–1307, 1975.
- [19] G. E. Box, G. M. Jenkins, and G. C. Reinsel, *Time Series Analysis: Forecasting and Control*, 3rd ed. Englewood Cliffs, NJ: Prentice Hall, 1994.
- [20] S. M. Disney, I. Farasyn, M. Lambrecht, D. R. Towill, and W. Van de Velde, "Creating win-win scenarios from the bullwhip problem ~ by design not accident," EUROMA POMS Conference, Como Lake, Italy, 2003.
- [21] N. S. Nise, *Control Systems Engineering*. CA: The Benjamin Cummings Publishing Company, Inc., 1995.
- [22] E. I. Jury, *Inners and Stability of Dynamic Systems*. London: John Wiley & Sons, 1974.
- [23] K. J. Åström, E. I. Jury, and R. G. Agniel, "A numerical method for the evaluation of complex integrals," *IEEE Transactions on Automatic Control*, vol. 15, no. 4, pp. 468–471, 1970.

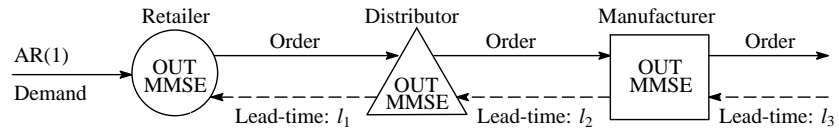

Fig. 1. Three echelon supply chain model

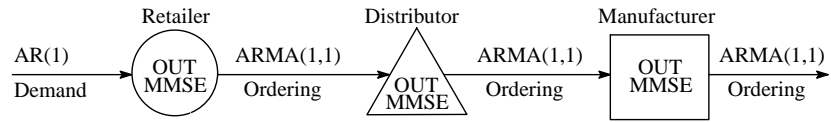

Fig. 2. Transition of the market demand

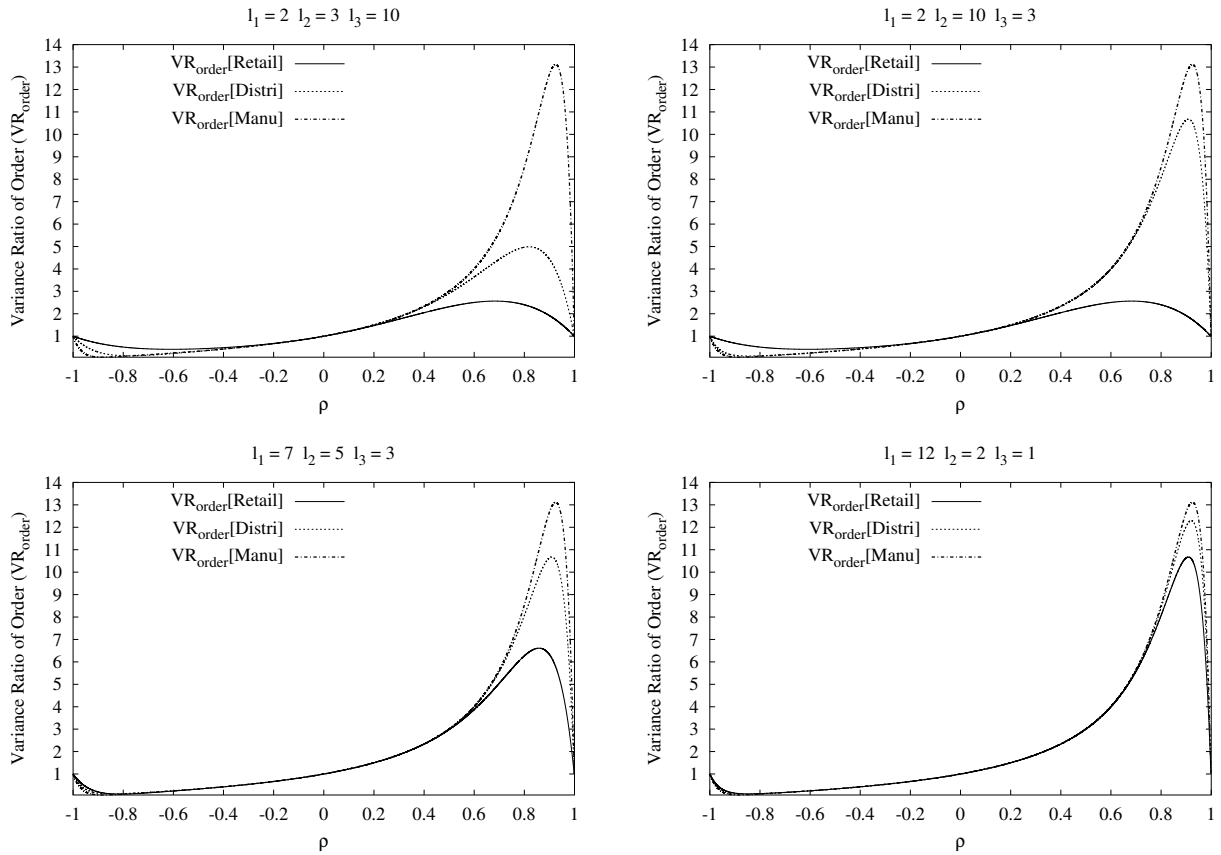

Fig. 3. Impact of value of  $\rho$  on the bullwhip ratios when  $l_1 + l_2 + l_3 = 15$

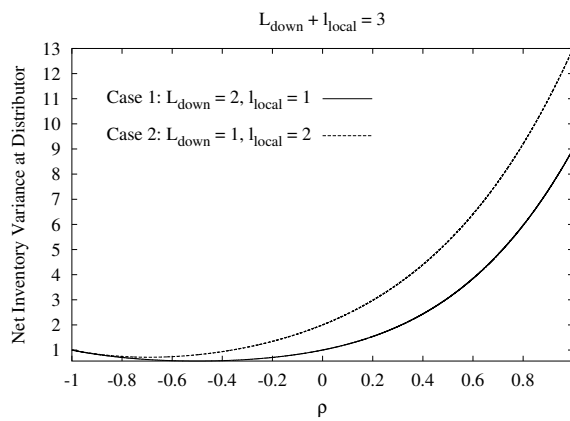

Fig. 4. Impact of  $l_{local}$  on the net inventory variance when  $L_{down} + l_{local} = 3$

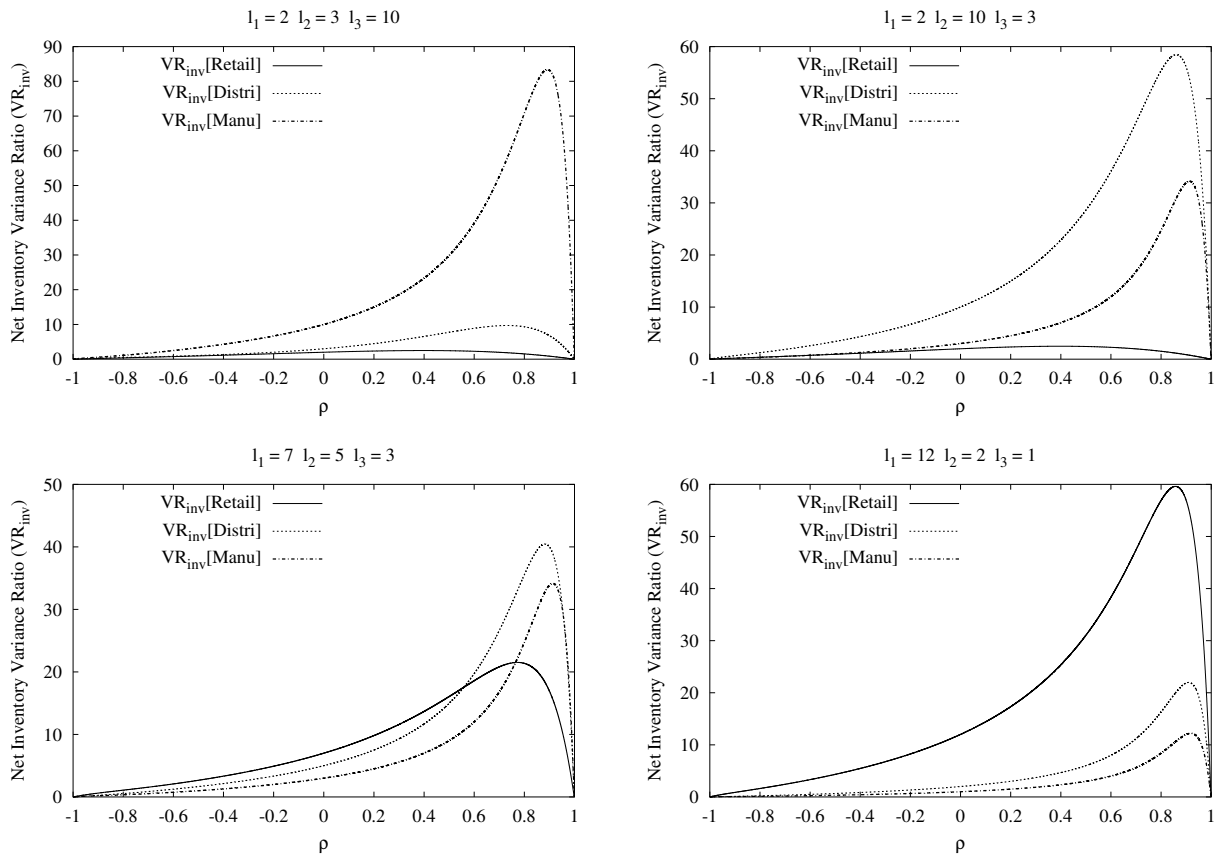

Fig. 5. Impact of value of  $\rho$  on the net inventory variance amplification ratio when  $l_1 + l_2 + l_3 = 15$

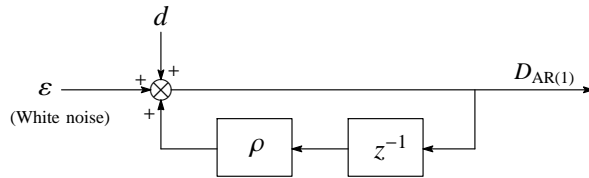

Fig. 6. Block diagram of AR(1) process

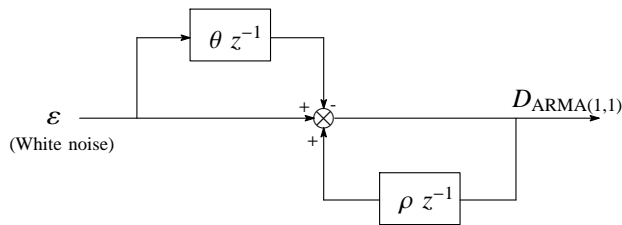

Fig. 7. Block diagram of ARMA(1,1) process



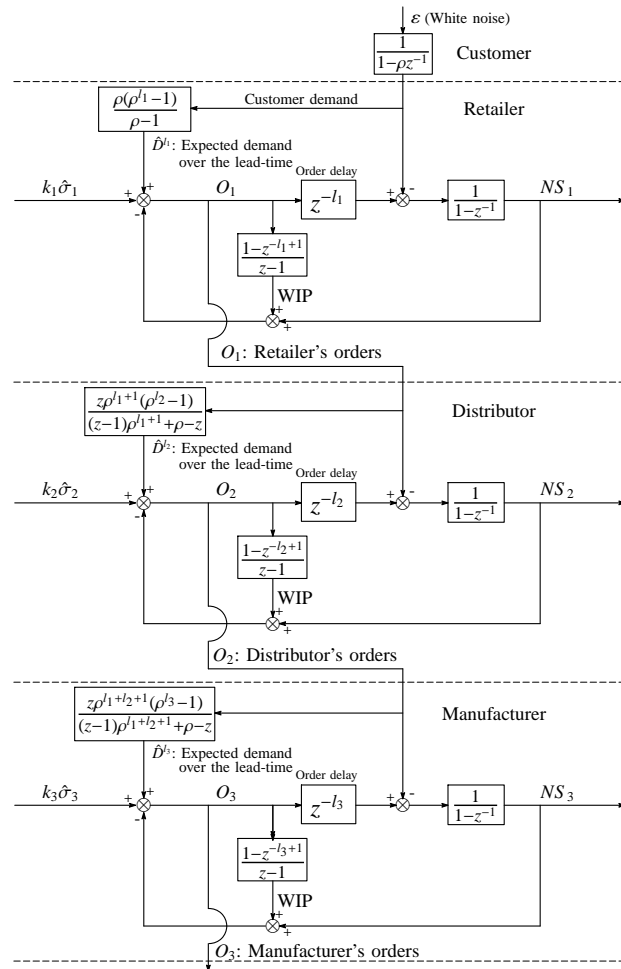

Fig. 8. Block diagram of three echelon supply chain with an OUT policy based on (2) with MMSE forecasting

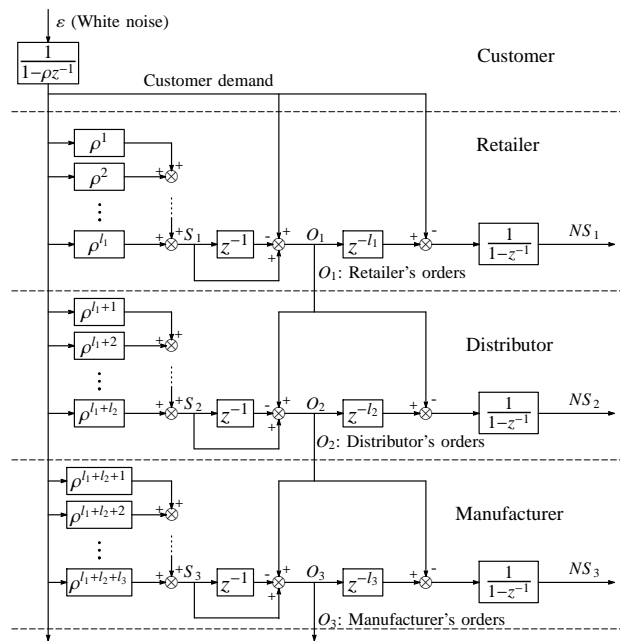

Fig. 9. Equivalent block diagram of our supply chain model