



AALBORG UNIVERSITY
DENMARK

Aalborg Universitet

Open Loop Transmit diversity solutions for LTE-A Uplink

Berardinelli, Gilberto; Sørensen, Troels Bundgaard; Mogensen, Preben; Pajukoski, Kari

Published in:
Proceedings of the European Signal Processing Conference

Publication date:
2010

Document Version
Early version, also known as pre-print

[Link to publication from Aalborg University](#)

Citation for published version (APA):
Berardinelli, G., Sørensen, T. B., Mogensen, P., & Pajukoski, K. (2010). Open Loop Transmit diversity solutions for LTE-A Uplink. *Proceedings of the European Signal Processing Conference*.

General rights

Copyright and moral rights for the publications made accessible in the public portal are retained by the authors and/or other copyright owners and it is a condition of accessing publications that users recognise and abide by the legal requirements associated with these rights.

- Users may download and print one copy of any publication from the public portal for the purpose of private study or research.
- You may not further distribute the material or use it for any profit-making activity or commercial gain
- You may freely distribute the URL identifying the publication in the public portal -

Take down policy

If you believe that this document breaches copyright please contact us at vbn@aub.aau.dk providing details, and we will remove access to the work immediately and investigate your claim.

OPEN LOOP TRANSMIT DIVERSITY SOLUTIONS FOR LTE-A UPLINK

Gilberto Berardinelli ⁽¹⁾, Troels B.Sørensen ⁽¹⁾, Luis Ángel Maestro Ruiz de Temiño ⁽²⁾,
Preben Mogensen ⁽¹⁾, Kari Pajukoski ⁽³⁾

⁽¹⁾ Department of Electronic Systems, Aalborg University, Denmark (e-mail: gb@es.aau.dk)

⁽²⁾ Nokia-Siemens Networks Innovation Center, Madrid, Spain

⁽³⁾ Nokia-Siemens Networks, Oulu, Finland

ABSTRACT

Transmit diversity (TD) techniques are expected to be included in the uplink of the upcoming Long Term Evolution - Advanced (LTE-A) systems to boost the user performance in low Signal-to-Noise Ratio (SNR) conditions. In this paper, several open loop TD solutions based on both space frequency coding (SFC) and space time coding (STC) are evaluated in a Single Carrier Frequency Division Multiplexing (SC-FDM) system with the aim of discussing their suitability for the upcoming standard. Traditional SFC is shown to increase the Peak-to-Average Power Ratio (PAPR) of the SC-FDM signal but it also outperforms STC for high speed and high order modulation and coding schemes (MCSs). Moreover, STC suffers from reduced flexibility in the time domain encoding. Starting from the single carrier sequences in the time domain, a SFC solution keeping low PAPR is derived; it is shown to be a valid option for low delay spread channels and small amount of data to be transmitted.

1. INTRODUCTION

The 3rd Generation Partnership Project (3GPP) is currently standardizing the Long Term Evolution - Advanced (LTE-A) systems [1]. The ambitious peak data rates that LTE-A aims at (1 Gbit/s in the downlink and 500 Mbit/s in the uplink) foresee the usage of advanced Multiple Input Multiple Output (MIMO) antenna techniques as well as a wide spectrum allocation (100 MHz and more). Orthogonal Frequency Division Multiplexing (OFDM) has been agreed as the downlink modulation scheme because of its flexibility for scheduling as well as its capability to efficiently cope with multipath [3]. Single Carrier Frequency Division Multiplexing (SC-FDM) has been selected for the uplink because of its advantageous low Peak-to-Average Power Ratio (PAPR) [4], which translates in lower power derating in the transmitter. This property allows a better power added efficiency in the User Equipment (UE) and improved coverage.

In the previous LTE Release 8 [2], MIMO solutions were standardized only for the downlink. The ambitious target of LTE-A, however, makes the use of MIMO mandatory even for the uplink. While MIMO spatial multiplexing schemes aim to improve the upper data rate by sending several data streams over multiple antennas in good channel conditions, transmit diversity (TD) techniques improve the coverage by enhancing the reliability of the data transmission. This makes TD solutions particularly suitable for UEs experiencing low Signal-to-Noise Ratio (SNR), e.g., UEs at the cell edge.

In this paper, we focus on open loop TD techniques for the uplink of LTE-A. Several solutions based on the well

known Alamouti principle [5] on both time and frequency domain are discussed and evaluated in terms of link performance as well as the PAPR. Our aim is obtaining useful insights on the suitability of the discussed techniques for the upcoming LTE-A standard, taking into account realistic impairments as channel estimation error as well as the low PAPR constraint of the SC-FDM technology.

The paper is structured as follows. Section II introduces the system model. Traditional Space Frequency Coding (SFC) and Space Time Coding (STC) algorithms are presented in Section III and IV, respectively. Section V deals with the derivation of SFC solutions starting from the time domain single carrier signals. The performance results are shown in Section V. Finally, Section VI presents the conclusions.

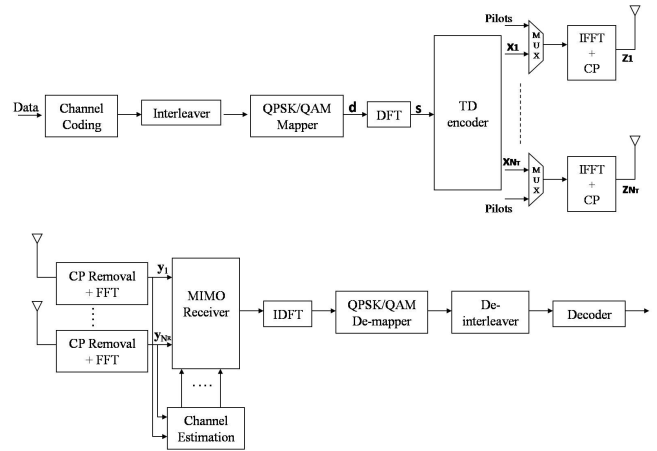

Figure 1: Simplified SC-FDM block diagram.

2. SYSTEM MODEL

A simplified baseband model of a MIMO SC-FDM transceiver chain with one codeword (CW), N_T transmit antennas and N_R receive antennas is depicted in Fig.1. On the transmitter side, the information bits are independently encoded, interleaved, and finally mapped to QPSK/M-QAM symbols, yielding the vector \mathbf{d} . Then, a Discrete Fourier Transform (DFT) is performed, spreading each data symbol over all the subcarriers, obtaining the vector \mathbf{s} . The complex symbols \mathbf{s} are then fed to the TD encoder block, which performs spatial transformation of the input symbols giving as an output the encoded MIMO symbols \mathbf{x} . Next, pilot symbols are inserted in predefined positions to enable channel

estimation at the receiver. Finally, an inverse fast Fourier transform (IFFT) is applied and a Cyclic Prefix (CP) is inserted to avoid the intersymbol interference (ISI). Assuming that the channel response is static over the duration of a SC-FDM symbol and that the CP is long enough to cope with the maximum excess delay of the channel [3], the received signal after CP removal and fast Fourier transform (FFT) can be written as follows:

$$\mathbf{y}[k] = \mathbf{H}[k]\mathbf{x}[k] + \mathbf{w}[k] \quad (1)$$

where $\mathbf{w}[k] = [w_1(k), w_2(k), \dots, w_{N_R}(k)]^T$ is the additive white Gaussian noise (AWGN) vector with $E[w_i(k)w_i(k)^*] = \sigma_w^2$ and

$$\mathbf{H}[k] = \begin{bmatrix} h_{11}(k) & \dots & h_{1N_T}(k) \\ \vdots & \ddots & \vdots \\ h_{N_R1}(k) & \dots & h_{N_RN_T}(k) \end{bmatrix} \quad (2)$$

is the channel transfer function matrix at subcarrier k . $h_{ij}(k)$ denotes the complex channel gain from the transmit antenna j to the receive antenna i .

The signal \mathbf{y} is then fed to the MIMO receiver block which performs equalization of the received symbols to compensate for the amplitude and the phase distortions introduced by the channel. To do so, an estimate of the channel transfer function is provided by the channel estimation block. The rest of the receiver chain performs the reverse operations of the transmitter side. Note that, in a SC-FDM system, an estimate of the data symbols is obtained after the Inverse Discrete Fourier Transform (IDFT) operation.

3. SPACE FREQUENCY CODING (SFC)

SFC Alamouti scheme provide redundancy by exploiting both frequency and space domains. The output of the TD encoder in the two neighbouring subcarriers $(i, i+1)$ can be written as follows:

$$\begin{bmatrix} x_1(i) & x_1(i+1) \\ x_2(i) & x_2(i+1) \end{bmatrix} = \frac{1}{\sqrt{2}} \begin{bmatrix} s_i & s_{i+1} \\ -s_{i+1}^* & s_i^* \end{bmatrix} \quad (3)$$

for i odd and with subindices on x referring to the two antennas ($N_T = 2$).

Note that the signal sent over antenna 1 is unmodified by the encoding. Assuming that the channel remains constant over the two neighbouring subcarriers, an estimate of the transmit frequency samples can be obtained according to the Maximal Ratio Combining (MRC) principle [5], as follows:

$$\tilde{s}_u = \sqrt{2} \frac{\sum_{m=1}^{N_R} [\tilde{h}_{m1}^*(u)y_m(u) + \tilde{h}_{m2}(u)y_m^*(v)]}{\sum_{m=1}^{N_R} [|\tilde{h}_{m1}(u)|^2 + |\tilde{h}_{m2}(u)|^2]} \quad (4)$$

$$\tilde{s}_v = \sqrt{2} \frac{\sum_{m=1}^{N_R} [-\tilde{h}_{m2}(u)y_m^*(u) + \tilde{h}_{m1}^*(u)y_m(v)]}{\sum_{m=1}^{N_R} [|\tilde{h}_{m1}(u)|^2 + |\tilde{h}_{m2}(u)|^2]} \quad (5)$$

with $u = i$, $v = i+1$, and i odd, where M is the number of subcarriers per SC-FDM symbol.

Since the TD encoder scrambles the order of the frequency samples to be transmitted by the second antenna, the low PAPR property of SC-FDM can be affected. Fig.2 shows the Complementary Cumulative Distribution Function (CCDF) of the PAPR of both Single Input Single Output (SISO) and SFC for different modulation schemes. OFDM SISO results are also included for the sake of comparison. It has to be mentioned that, for OFDM, the PAPR remains the same regardless of the modulation or encoding scheme [6]. SFC leads to a PAPR penalty of around 0.5 dB in the second antenna with respect to SISO; however, even for 64QAM a gain of around 1.5 dB over OFDM is still preserved.

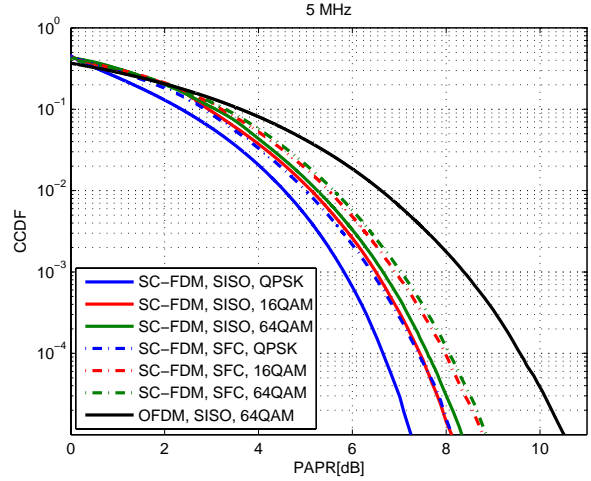

Figure 2: PAPR performance of SFC vs. SISO.

4. SPACE TIME CODING (STC)

In the STC scheme, symbols are coded in both space and time to add redundancy. Since in a SC-FDM system the space coding is still done in frequency domain, the Alamouti scheme is applied to the whole subcarriers' set to emulate a time-domain Alamouti operation. In our system, the dimension of the set corresponds to the DFT size. The output of the encoder for the first two sets of subcarriers can be expressed as:

$$\begin{bmatrix} x_1(0) & x_1(1) & \dots & x_1(2M-1) \\ x_2(0) & x_2(1) & \dots & x_2(2M-1) \end{bmatrix} = \frac{1}{\sqrt{2}} \begin{bmatrix} s_0 & \dots & s_{M-1} & -s_M^* & \dots & -s_{2M-1}^* \\ s_M & \dots & s_{2M-1} & s_0^* & \dots & s_{M-1}^* \end{bmatrix} \quad (6)$$

Note that each group of M subcarriers forms a SC-FDM symbol after IFFT operation. Of course, the PAPR of the signals over both antennas is not modified by the encoding since the conjugating operation is performed over the whole subcarriers' set.

The MRC detector aiming at retrieving the information in the same subcarrier over two adjacent time symbols can be expressed as in Eq.(4) and Eq.(5) assuming $u = i$, $v = i+M$, with $i = 0, \dots, M-1$. Again, the MRC detector works with the assumption that the channel remains constant over the two adjacent time symbols which are paired by the Alamouti encoding.

Note that STC requires an even number of time symbols in the SC-FDM frame: this reduces the flexibility of this scheme since in a real system some of the time symbols may be occupied by sounding reference signals (SRSs) instead of data [2].

5. DERIVATION OF LOW PAPR SFC SCHEMES

In the previous sections the most known approaches to perform Alamouti encoding across time or frequency domains have been presented. SFC results to be more flexible than STC since it does not require any assumption on the number of time symbols in a frame. However, the low PAPR of the transmit signals is compromised since their single carrier property is lost. Note that a time domain sequence can be considered as a *single carrier sequence* if the power amplitude of each sample corresponds to the one of a known symbol constellation.

In this section, we elaborate on the design of space frequency coding solutions starting from the single carrier sequences in the time domain. Our aim is to obtain a scheme which does not compromise the low PAPR property of the uplink signals. In order to facilitate the discussion, let us define the following two criteria:

- *Alamouti criterion.* Given two complex sequences $\mathbf{a} = [a_0, a_1, \dots, a_{\bar{N}-1}]$ and $\mathbf{b} = [b_0, b_1, \dots, b_{\bar{N}-1}]$, we claim that they fulfill the Alamouti criterion if and only if $\forall i \in \{0, 1, \dots, \bar{N} - 1\}$ there is always $j \in \{0, 1, \dots, \bar{N} - 1\} - \{i\}$ so that the matrix

$$\begin{bmatrix} a_i & a_j \\ b_i & b_j \end{bmatrix} \quad (7)$$

is an orthogonal matrix.

- *Contiguity criterion.* Given the previously defined complex sequences \mathbf{a} and \mathbf{b} , we claim that they fulfill the contiguity criterion if and only if

$$b_i = a_{(\bar{N}-i-q) \bmod \bar{N}}^* e^{j\phi(i)}, \quad \text{for } i = 0, \dots, \bar{N} - 1 \quad (8)$$

or

$$b_i = a_{(i-\bar{N}-q) \bmod \bar{N}}^* e^{j\phi(i)}, \quad \text{for } i = 0, \dots, \bar{N} - 1 \quad (9)$$

where $\phi(i)$ is a linear function of i and q is a generic integer number. It is worth to notice that in Eq.(8) the samples b_i conjugate and revert the order of the samples a_i , while in Eq.(9) the samples b_i conjugate and cyclically shift the positions of a_i .

Of course, space frequency coding can be performed over frequency sequences fulfilling the Alamouti criterion. It can be shown that, given the two time domain single carrier sequences \mathbf{d} and $\tilde{\mathbf{d}}$, the necessary condition so that the corresponding frequency domain sequences respect the Alamouti criterion is that \mathbf{d} and $\tilde{\mathbf{d}}$ follow both the Alamouti and the contiguity criteria. If \mathbf{d} corresponds to a vector of data symbols, according to the contiguity criterion the sequence $\tilde{\mathbf{d}}$ is simply a conjugate, sample and phase shifted version of \mathbf{d} .

In the following, we elaborate on the sequence $\tilde{\mathbf{d}}$ which in our framework represents the generated time domain sequence over the second antenna, while the sequence \mathbf{d} over

the first antenna is unmodified. We assume that the sequence $\tilde{\mathbf{d}}$ has length M , hence corresponding to the equivalent pre-DFT signal (see Fig.1). However, the effective time domain signal sent over the air is simply an oversampled version of this sequence, thus not altering its low PAPR property.

According to Eq.(8) and Eq.(9), let us consider the following two cases:

- *Conjugated cyclically reverted samples.* In this case, the generic element of the sequence $\tilde{\mathbf{d}}$ can be written as:

$$\tilde{d}_i = d_{(M-i-q) \bmod M}^* e^{j\phi(i)} \quad (10)$$

for $i = 0, \dots, M - 1$. It can be easily verified that, by assuming $\phi(i) = \pi(i + 1 + 2\frac{iP}{M})$, with P integer, the sequences \mathbf{d} and $\tilde{\mathbf{d}}$ also respect the Alamouti criterion. The equivalent frequency domain samples on the second antenna, obtained by applying a DFT operation over $\tilde{\mathbf{d}}$, are given by:

$$\tilde{s}_k = (-1)^{M-q+1} e^{j\frac{2\pi}{M}(P-k)(M-q)k} s_{(k-\frac{M}{2}-P) \bmod M}^* \quad (11)$$

for $k = 0, \dots, M - 1$. It can be noticed that the position of the frequency samples on the second antenna does not depend on the value q of the time domain shift, which is absorbed in a phase term. Furthermore, the sequences \mathbf{s} and $\tilde{\mathbf{s}}$ respect the Alamouti criterion only for $P = zM$, with $z \geq 0$. As a consequence, the Alamouti coding in the frequency domain results to be applied over samples having constant distance equal to $M/2$ subcarriers. This can severely affect the performance of the MRC detector in case of a frequency selective channel.

- *Conjugated cyclically shifted samples.* The generic element of the sequence $\tilde{\mathbf{d}}$ can in this case be expressed as:

$$\tilde{d}_i = u_{(i-M-q) \bmod M}^* e^{j\phi(i)} \quad (12)$$

for $i = 0, \dots, M - 1$. The Alamouti criterion between sequences \mathbf{d} and $\tilde{\mathbf{d}}$ is fulfilled by assuming $\phi(i) = \pi\left(M - P + 1 + 2\frac{i(M-P)}{M}\right)$. The equivalent frequency domain sequence is given by:

$$\tilde{s}_k = (-1)^{M-P+1} e^{j\frac{2\pi}{M}(M+q)(M-P-k)} s_{(M-P-k)}^* \quad (13)$$

for $k = 0, \dots, M - 1$. Here, the sequences \mathbf{s} and $\tilde{\mathbf{s}}$ always fulfill the Alamouti criterion. It is worth to notice that, by selecting $P = M/2 + 1$, we obtain the lowest average distance between the frequency samples where the Alamouti principle is applied. The frequency distance is indeed comprised between 1 to $M/2 - 1$ samples, thus in any case lower than in Eq.(11). By further assuming $q = M/2$, we obtain the following compact expression for the sequence $\tilde{\mathbf{s}}$:

$$\tilde{s}_k = (-1)^{k+1} s_{(\frac{M}{2}-k-1) \bmod M}^* \quad (14)$$

In the numerical evaluation we will only consider the solution in Eq.(14) as low PAPR SFC scheme because of its lower average distance between coupled Alamouti frequency samples. The output of the MRC detector can be written as for SFC assuming $u = (o-1)\frac{M}{2} + i, v = o\frac{M}{2} - i - 1$, with $o = 1, 2$ and $i = 1, \dots, \frac{M}{4} - 1$.

Table 1: Simulation parameters

Carrier frequency	2 GHz
Sampling frequency	15.36 MHz
Subcarrier spacing	15 KHz
FFT size	1024
CP length	$5.2^a/4.68^b \mu s$
Frame duration	1 ms
SC-FDM symbols per Frame	14
MCS settings	QPSK: 1/6, 1/3, 1/2, 2/3 16QAM: 1/2, 2/3, 3/4 64QAM: 2/3, 4/5
Channel Coding	3GPP Rel.8 Turbo code

^a 1st, 8th SC-FDM symbol in a frame.

^b 2th – 7th, 9th – 14th SC-FDM symbol in a frame.

6. PERFORMANCE EVALUATION

The proposed TD schemes were evaluated with an LTE-compliant MATLAB simulator. The main simulation parameters are shown in Table I. Two different channel models are considered: typical urban 6 paths (TU06) and urban micro spatial channel model (SCMD), with coherence bandwidths of 200 kHz and 1 MHz, respectively [7]. Each data frame has a duration of 1 ms, and is formed by 14 SC-FDM time symbols. It is assumed that the 4th and the 11th symbol carry the pilots which enable the channel estimation at the receiver.

In Fig.3, SFC and STC are compared with single transmit antenna, for TU06 and a transmission bandwidth of 5 MHz. It is further assumed 16QAM with coding rate 2/3, low speed (3kmph) and full channel knowledge (full chKnol) at the receiver. Note that a transmission bandwidth of 5 MHz corresponds in the LTE numerology to 300 subcarriers, i.e. 25 Resource Blocks (RBs). The additional diversity gain provided by SFC with respect to 1x2 and 1x4 configurations is evident from the slope of the Packet Error Rate (PER) curves. The gain over single transmit antenna schemes is up to 2.5 dB in 2x2 case and 1.5 dB in 2x4 case. No relevant performance difference is visible between SFC and STC, since the frequency separation between adjacent subcarriers is much lower than the coherence bandwidth of the TU06 channel, and at low speed the channel does not change significantly between adjacent time symbols. The MRC detector can therefore work properly for both SFC and STC schemes. For high speed (150 kmph), SFC outperforms STC in the 2x2 case (see Fig.4) by around 0.5 dB as the channel response changes significantly between adjacent time symbols. However, when real channel estimation is considered, the performance gap between SFC and STC schemes turns out to be negligible. For channel estimation based on Robust Wiener (RW) filtering [8] in the frequency domain and linear interpolation in the time domain (between the responses obtained from the 4th and the 11th time symbols), the error due to estimation in frequency direction at high speeds results to be more critical than the error in the time direction. This is because of the incurring of Inter-Carrier Interference (ICI). This explains the higher losses for SFC compared to STC when real channel estimation is considered (RW). Note

that in 2x4 case both schemes perform equivalently thanks to the higher diversity gain of the 4 receive antennas.

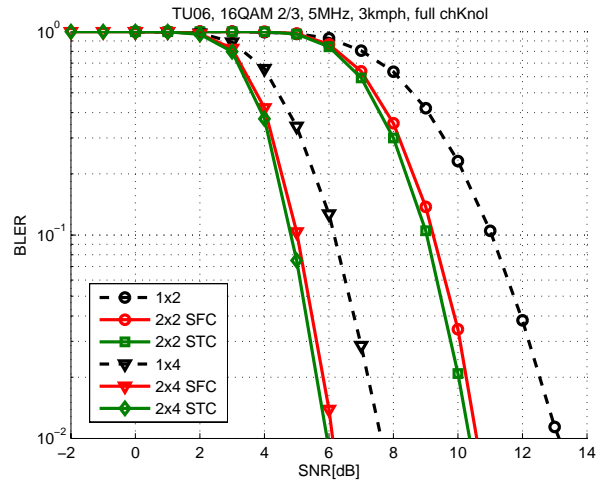

Figure 3: SFC/STC performance for low speed.

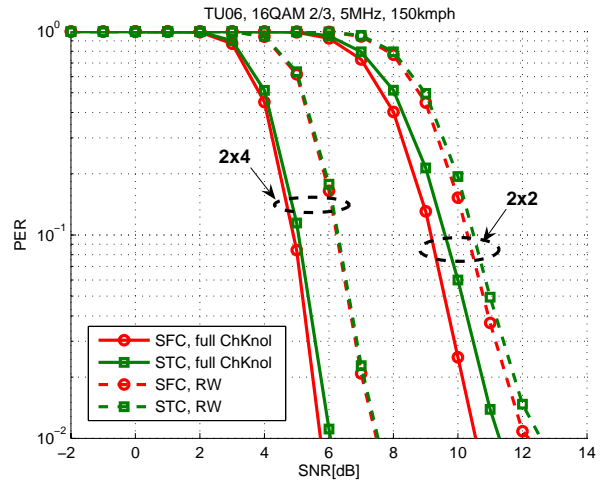

Figure 4: SFC/STC performance for high speed: full chKnol vs. RW.

The performance results over the whole SNR range are shown in Fig.5 in terms of link adaptation curves, obtained as the envelope of the spectral efficiency curves for several modulation and coding schemes (MCSs). The high speed leads to some performance loss at high SNR region because of the sensitivity of the high order MCSs to ICI, but, as expected, STC performs worse than SFC. However, both transmit diversity solutions are effective in low-medium SNR region, where these techniques are more likely to be used. Furthermore, the increase of diversity in the 2x4 configuration allows to reduce the gap with the 3kmph case, and at the same time makes the two techniques have the same performance. In the TU06 scenario low PAPR SFC fails completely (PER equal to 1 over the whole SNR range). This is a result of the frequency separation (up to 150 subcarriers) between the pair of samples being encoded in the Alamouti TD operation, a frequency separation which is much wider than the

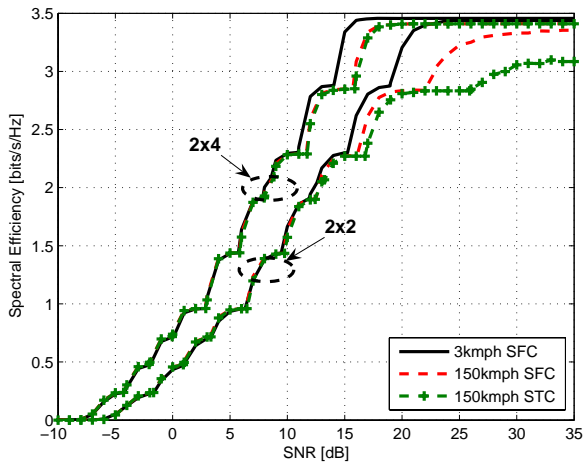

Figure 5: Link adaptation curves for 2x2 and 2x4 configurations.

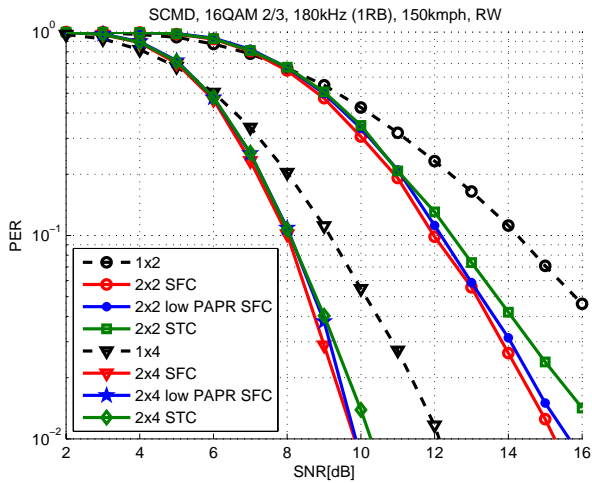

Figure 6: SFC, STC and low PAPR SFC performance with SCMD and 1 RB.

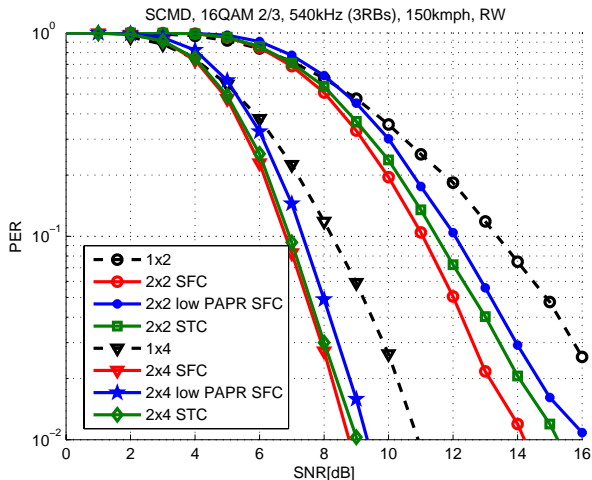

Figure 7: SFC, STC and low PAPR SFC performance with SCMD and 3 RBs.

coherence bandwidth of the TU06 channel. The suitability of low PAPR SFC is therefore evaluated with SCMD and assuming a very small user bandwidth to reduce the frequency separation between the paired subcarriers. Fig.6 shows the results obtained assuming the UE moving at 150 kmph and transmitting over 1 RB (12 subcarriers). In this scenario low PAPR SFC slightly overcomes STC in a 2x2 configuration. For an UE transmitting over 3 RBs (see Fig.7), STC turns to overcome low PAPR SFC, even though their gap is below 0.4 dB. Note that a gain up to 1.8 dB over 1x2 and 1x4 is preserved. Therefore, low PAPR SFC can still provide additional diversity gain with respect to single transmit antenna solutions without incurring a PAPR penalty and avoiding the STC's constraint of having an even number of time symbols.

7. CONCLUSIONS

In this paper, we have discussed the suitability of a few open loop TD solutions for the uplink of the upcoming LTE-A systems. Both SFC and STC approaches are considered. SFC suffers from a PAPR penalty, whereas STC has reduced flexibility for the time domain encoding. Both approaches have about the same performance at low speed. At high speed SFC overcomes STC in a 2x2 antenna configuration, and especially for high order MCSs, but with increased diversity (2x4) their performance is again the same. The PAPR penalty of SFC can be avoided by using a modified allocation of the frequency samples; this solution results to be valid for UEs transmitting a small amount of data over a low frequency selective channel.

REFERENCES

- [1] "Requirements for further advancements for E-UTRA (LTE-Advanced)", 3rd Generation Partnership Project, Tech. Rep. TR 36.913, V8.0.0, 2008.
- [2] "LTE Physical Layer - General Description (Release 8)", 3rd Generation Partnership Project, Tech. Rep. TS 36.201, V8.1.0, Nov. 2007.
- [3] L. Hanzo, M. Munster, B. Choi, and T. Keller, *OFDM and MC-CDMA for Broadband MultiUser Communications, WLANs and Broadcasting*. John Wiley - IEEE Press, 2003.
- [4] H. Myung, J. Lim, and D. Goodman, "Single carrier FDMA for uplink wireless transmission", *Vehicular Technology Magazine*, IEEE, vol. 2, no. 3, pp. 30-38, September 2006.
- [5] S. Alamouti, "A simple transmit diversity technique for wireless communications", *IEEE Journal on Selected Areas in Communications*, vol. 16, no. 8, pp. 1451-1458, October 1998.
- [6] B. Priyanto, G. Berardinelli, and T.B. Sørensen, *Single Carrier Transmission for UTRA LTE Uplink*, Long Term Evolution : 3GPP LTE Radio and Cellular Technology Handbook, CRC Press.
- [7] "Physical layer aspects for evolved Universal Terrestrial Radio Access (UTRA)", 3rd Generation Partnership Project, Tech. Rep. TS 25.814, V7.1.0, 2006.
- [8] O. Edfors, M. Sandell, J. van de Beek, and S. Wilson, "OFDM channel estimation by singular value decomposition", *IEEE Transactions on Communications*, vol. 46, no. 7, pp. 931-939, July 1998.