

# Operation and Control of Space-Based Solar Energy Power Plants With CCGT Using Helium as a Working Medium

A. SUTSCH

Institute for Computer-Assisted  
Research in Astronomy  
Alterswil, Switzerland

## ABSTRACT

The features of a Space-based Solar Energy Power Plant for electric power generation with a closed cycle gas turbine running on Helium are discussed. The system is intended for generating both electricity and process heat for industrial manufacturing processes in a large space station. A system overview for operation and control of such a plant is presented.

## NOMENCLATURE

AI	artificial intelligence
BERAL	beryllium-aluminium coating
CCD	charge coupled device sensor
CCGT	closed cycle gas turbine
D	diameter
Dish	collector of parabolic shape
F	focal length
F/D	focal length to diameter ratio
HCCGT	Helium Closed Cycle Gas Turbine
LPDS	Large Parabolic Dish System
PCU	power conversion unit
PV	photo-voltaic
SEPP	Solar Energy Power Plant
SSEPP	Space-based Solar Energy Power Plant
UV	ultra-violet spectrum

## INTRODUCTION

The recent flights of the Space Shuttle have demonstrated the feasibility of using space as a production environment for industrial processes that cannot be carried out on earth due to gravity or the necessity of an absolute vacuum in such areas as electronics (purity of materials), bio-chemistry, medical research, gene technology, etc.

Besides the use of space stations for research and military bases, the industrial use of space as a manufacturing platform will become an important aspect of special economic value in the near future. The go-ahead has been given recently for the design of a large space station by the USA to be launched within the next decade; the USSR has been operating a space station of moderate size for several years.

Space stations as an industrial production environment require large amounts of energy, electricity, process heat, as well as heating for personnel working inside the station.

This paper is attempting to show the technological and economic feasibility of using large parabolic dish systems equipped with a helium driven closed cycle gas turbine (HCCGT) utilizing solar energy for electricity and process heat production coupled to a large space station: the electricity consumption is considered to fall within the range of 50 MW and 300 MW for such space stations in an industrial production environment. An equal to slightly larger amount of thermal energy can be extracted from a HCCGT for industrial process heat applications to bring total plant efficiency exceeding 70 % of the input primary energy.

The experience gained in West-Germany operating closed cycle gas turbines over the past 25 years and in particular the design and operation of the Oberhausen Helium Turbine plant permit the transfer of this technology to the space environment. The Oberhausen Helium Turbine plant heating the gas with conventional fuel was intended as a test for commercial power plant use of the helium technology for the high temperature reactor using helium as a cooling fluid.

Operation of a large parabolic dish system equipped with a helium closed cycle gas turbine differs from earth-bound installations considerably; space offers features for the HCCGT that are worth studying, like:

- external pressure is zero,
- outside temperature is near absolute zero K,
- compressor inlet temperatures can be extremely low and thus yield excellent Carnot cycle performances for the HCCGT,
- constant solar radiation as direct radiation at 1353 Watts per square meter for any 24 hour period permits running the HCCGT always at the design point,
- large parabolic dish acts as a protective radiation shield for the space station and its personnel against hard UV and X-rays.

This paper is intended to give a collective overview of the possibilities of SSEPP with HCCGT technology.

Further applications of this concept can be found in micro wave transmission of electric energy to earth, as studied under the SPS - Solar Power Satellite concept [1], as well as military applications like the use for electricity generation under SDI.

#### HISTORICAL REVIEW

In 1923 Oberth published "The Rocket into Interplanetary Space [2] which besides laying the ground for the design of interplanetary rockets mentions on page 87 under "Future Aspects" a large space mirror to direct solar energy in the form of concentrated light towards earth; his later work "Man into Space" [3] 1925 goes into great constructional detail (Chapter 5: The Space Mirror) of such a large space mirror. He discusses a mirror with 100 km diameter - with the technology available at that time! The applications then do not include the use of turbines as they had not been invented yet.

In the early sixties six CCGTs were designed and installed in Germany [4]; the HCCGT was commissioned in 1974 [5] and is still in operation today. Bammert has reported on these installations on various occasions [4]. Of these CCGT installations, the Coburg CCGT Power Plant is still running today having accumulated more than 150'000 running hours, an excellent record by any standard!

The total aggregate experience in running hours of CCGTs in Germany over the years exceeds 600'000 hours; it is this record of accumulated experience that allows us to apply this technology to space based systems for power generation systems in conjunction with solar energy technology; the components are very similar: the receiver in a solar power plant of the Large Parabolic Dish Type - LPDS is the radiation part of the heater in a CCGT.

When the author conceived SEPP - Solar Energy Power Plant in 1976, he intended a helium turbine to be used as a prime mover; after the contact with Bammert in 1977, it was clear that earth-bound systems of small power ratings of SEPP's did not allow the design of such small helium turbines for practical and economic reasons (power range 250 kw - 2000 kw)[6]. With space-based large solar power stations, this concept becomes a viable solution. An overview of the advantages and a layout of a Large Parabolic Dish System for solar power generation has been given in [7] and [8].

#### SYSTEM DESCRIPTION

In space stations that run industrial processes, an electric power output of 50 MW with the use of another 60 MW (thermal) is assumed in the example discussed in this paper; some figures for a larger station of 300 MW (electric) are mentioned as a guide line to scaling the properties of the system. Table 1 shows comparative figures on the SSEPP system concept.

#### PARABOLIC DISH CONCEPT

SSEPP is based on the high energy concentration factor of a parabolic dish to concentrate the incident solar radiation onto the focal area; this volume of extremely high temperature is located inside the receiver, where the radiation energy is transferred through the use of high quality alloy tubing to the working medium of the cycle in the form of thermal energy, in the case discussed here: helium.

TABLE 1  
COMPARATIVE FIGURES SSEPP SYSTEM

SSEPP generating capacity	50 MW(el)
Parabolic dish diameter	374 m
Parabolic dish surface	110'100 square meters
F/D ratio	0.6
Concentration ratio	>= 6'000
Solar constant	1353 W per square meter
Positional accuracy on sun disk	<= 1"
Position sensor type	CCD - Charge Coupled Device with sub-pixel resolution
Reflector panel size	2 m x 2 m flat
Reflectivity of foil used	92 % long term
Thickness of reflective foil	app. 10 microns
Receiver opening minimum diameter	3 m
Receiver efficiency (est.)	87 %
Rotational speed of SSEPP	1 < R < 10 [Rpm] variable
Helium replenishment per day	5 kg
Helium turbine inlet temperature	800 degrees Celsius
Heat capacity Helium/Air	20 : 1
Assumed cycle efficiency	42 %
Net electric efficiency at terminals	33.61 %

The working principle of SEPP using air as a working medium in an open cycle gas turbine has been described in the literature [6 - 10]. The basic differences of SEPP and SSEPP are listed in Table 2. Not only does it show that commercial size power stations in the 50 MW range operated in space offer significant advantages over solar power stations on earth, but the conditions for converting solar energy to electricity with thermal power plant units in space can be much more efficient due to the very low compressor inlet temperatures (exterior ambient temperature being close to absolute zero).

Figure 1 shows the principal elements of SSEPP coupled to a space station. The entire solar constant arrives in the form of radiation energy with 1353 W/m<sup>2</sup> on the dish surface (1) consisting of an extremely thin reflective foil glued to the support frames. There are no transmission losses due to front-surface reflection on the foil. Radiation arrives at the receiver (2) without transmission losses due to the absence of an atmosphere; the only loss factor is radiation spillage around the receiver opening due to misalignment of panels; this is encountered by the "trumpet shape factor" of the receiver opening (3). Radiation hits the receiver tubes and walls and transfers its energy onto the receiver tubing (4) through multiple reflections or direct radiation. Reradiation

losses can be kept to a minimum given the correct geometry of the receiver inside. The energy is transferred onto the working medium (helium) driving the turbine (5, 6); via the gearbox (7), the generator (8) is driven producing electric energy.

#### OPTICAL PROPERTIES

The focal length to dish diameter ratio is kept at the maximum value for a usable concentration factor given the mechanical properties of the receiver; in this case a value of F/D = 0.6 is assumed. This results in a rim angle that allows the window opening of the receiver to be small enough to minimize reradiation losses. With this F/D ratio a concentration factor of app. 6'000 can be reached. Mechanical, constructional, and service questions favor the use of a secondary Cassegrainian reflector (9) which allows the power conversion unit to sit closer to the dish vertex and make use of the shaded side of the dish for a radiative heat exchanger (10). This design results in a very deep dish with a strongly aspheric secondary reflector. Due to the absence of gravity, constructional considerations do not disfavor this concept.

The reflective panels consist of a light tubular frame of app. 2 x 2 m sides onto which the extremely thin foil (10 microns) is glued as shown in detail (11) in Fig. 1. The foil is plastic front-surfaced with reflective material of app. 92 % long-term reflectivity (aluminium, BERAL, etc.). The individual panel is a flat surface which results in a minimum receiver opening of 3 m including a nominal amount of optical spillage.

The dish structure with its large surface area of 110'100 m<sup>2</sup> (for 50 MW[el]) is placed in front of the space station and thus offers a radiation shield against the intense UV and X-ray radiation emanating from the sun.

Optical sensors transmitting positional information to the control computer systems are coupled to small firing jets using conventional hydrozine fuel to keep the dish assembly locked to the solar dish center.

#### POWER CONVERSION UNIT

The entire structure dish and power conversion unit is slowly rotating around its central axis to provide directional stability to the system; the angular momentum is provided by the turbine/generator assembly with counter-rotating stators. Depending on the industrial processes executed inside the space station, the station can be coupled or de-coupled from the artificial gravitational field caused by the rotating SSEPP assembly.

The power conversion unit (PCU) is mounted on the central axis of the paraboloid. The properties of energy conversion and receiver design for parabolic dish system type solar power plants have been described at length in the literature [10], etc. by Bamert et. al. Here, only the differences to conventional design strategies for space-based SSEPP's are mentioned.

The primary difference of SSEPP to earth-based systems is the use of a helium closed cycle gas turbine - HCCGT. Turbines operating in space can only be of the closed cycle design type due to the lack of ambient air or atmosphere.

Helium as a working medium lends itself to the use in SSEPP stations due to its very high heat capacity and being an inert gas it cannot interact with the system components. The high heat capacity value of app. 20 times that of air renders the turbine and compressor construction much smaller and allows higher running speeds due to the very high speed of sound of helium. The diffusion properties of helium are manageable and can be estimated to app. 5 kg of helium per day for a 50 MW(el) plant, as has been experienced in the Oberhausen Helium Turbine Plant over the past 11 years.

The principle cycle diagram for a space-based HCCGT is presented in Figure 2. [5]. Helium is heated to its process temperature (800 degrees C) in the receiver (a), is expanded in the high pressure turbine (b) and the low pressure turbine (c), passes to the recuperator (d) where it transmits a large portion of its energy to the newly compressed gas, then the gas from the turbine enters the coolers (e') and (e'') which are industrial process specific heat exchangers or radiative heat exchangers for space operation that cool the gas to very low temperature values of app. 100 degrees K, from there the cold gas flows into the low pressure compressor (f), then enters a radiative intercooler (g) where the partially compressed gas is again cooled down to very low temperature levels either by radiative coolers in the space environment or for extracting process heat needed, then flows through the high pressure compressor (h) from where it is heated in the recuperator (d) and then enters the receiver (a) again to close the cycle. Auxiliary equipment for adding helium to the cycle and bringing it up to the required pressure, as well as bypass valves are also shown in the diagram.

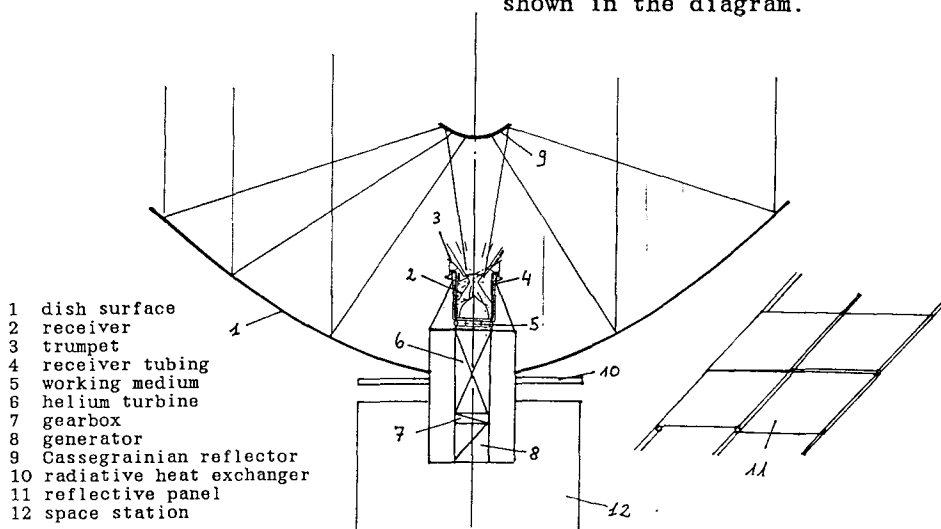
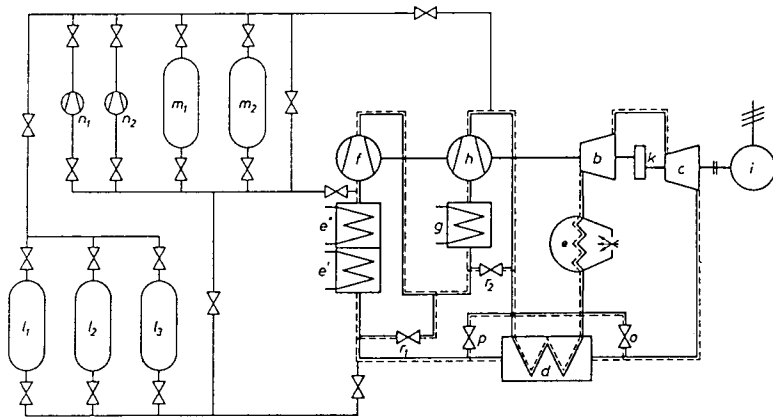

Figure 1 - Principle Elements of SSEPP





- a receiver
- b high pressure turbine
- c low pressure turbine
- d recuperator
- e' precooler - heating part
- e'' precooler - cooling part
- f low pressure compressor
- g intercooler
- h high pressure compressor
- i generator
- k gearbox
- l1, l2, l3 control containers
- m1, m2 storage containers
- n1, n2 charge compressor
- o control valve
- p fast opening valve
- r1, r2 bypass

Figure 2 - Helium Turbine Cycle Diagram

sophisticated hard- and software with its 5 onboard computers that check each other.

SSEPP takes a similar approach on a more modern basis: complex systems such as a space station's energy consumption and power generation station can be best monitored and checked continuously by an artificial intelligence system coupled to a suitable computer and sensor system.

In contrast to the conventional approach for monitoring sensor inputs and reacting if certain levels have been exceeded and then detecting or preventing a malfunction because of early warning levels, an artificial intelligence (AI) system constantly compares complex states and combinations and calculates reliable deductions and probabilities from changing sensor inputs in accordance with its internal rule structure; the mere database approach only serves as a raw input device: the system with AI comes to its own conclusions and acts accordingly without human interaction and without any preprogrammed conditions.

Hardware and software have to be used in a redundant form: several AI systems always monitor the entire installation and compare results for their probability before initiating a request for change or human service interaction.

This type of approach provides a more secure operation; multiple sensors for a given condition or state give their input into the systems; the computers can detect themselves whether a sensor is reading a correct value or transmitting its own faulty state.

Optical sensors of the CCD array type keep the dish always locked to the sun's center for optimum efficiency; motion control for the entire assembly is achieved by small jets (conventional hydrazine fuel). The rotation of the dish system is checked via angular motion detectors in comparison with prominent star image positions for varying loads on the turbine.

### ECONOMIC CONSIDERATIONS

Providing energy for a space station at the levels discussed can be achieved with three systems:

1. Nuclear reactor
2. Photovoltaic system
3. SSEPP

The nuclear reactor represents a viable solution on the basis of the gas-cooled high temperature reactor (helium cooling); to date there is no commercial operating experience with this type of reactor so that operation in space seems to be not appropriate.

A photovoltaic system for the amount of electric power required would have gigantic dimensions: at the present efficiency ratio of app. 10 percent for affordable solar cells (1986), a field of 370'300 m<sup>2</sup> would be required or more than 3.3 times the size of the dish surface. This would only provide electricity without any process heat possibility in the system so that an additional system for process heat application would have to be installed; if this was to be achieved in the form of solar cells, the additional field size would account for another 440'000 m<sup>2</sup>. These figures clearly speak against the advantage of almost attendance free PV systems as they are being used in satellites today. The mass for lifting these dimensions into space and connecting them electrically counteracts the advantages.

The SSEPP system remains the only alternative at present for producing large quantities of energy in space; space stations of the size envisaged always have personnel for service and repair besides the normal operating personnel for industrial production processes. A maintenance crew for the SSEPP can be a very small team due to the autonomous system design and control philosophy of the entire plant (Artificial Intelligence).

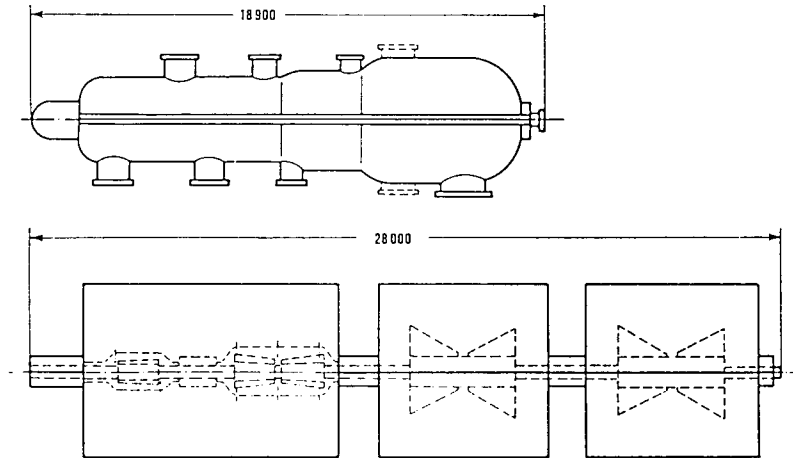

Figure 3 - Comparative Sizes of 300 MW(El) Helium and Steam Turbo Set

CONCLUSION

With the advent of space as an industrial production environment, power plants to provide energy for large space stations have to be developed. Among the possible alternatives, the Space-based Solar Energy Power Plant - SSEPP presents the best solution from a technological and economic point of view.

The principal features of a Space-based Solar Energy Power Plant - SSEPP for producing electricity and industrial process heat for large space stations for industrial production facilities has been presented. The large parabolic dish concept utilizing a closed cycle gas turbine running with helium as a working medium presents a viable solution for this application [12].

More than 600'000 operating hours of CCGTs and the experience gained with the helium Turbine in Oberhausen / Germany permits the transfer of this technology to space-based operations. The advantages of SSEPP in comparison with earth-based stations have been enumerated: continuous direct solar radiation at the solar constant level, the extremely low mass requirements for the large dish structure due to the absence of gravity, to only mention a few.

A new approach in plant control with Artificial Intelligence computer systems keeps human interaction with the process to a minimum and can provide a widely autonomous system.

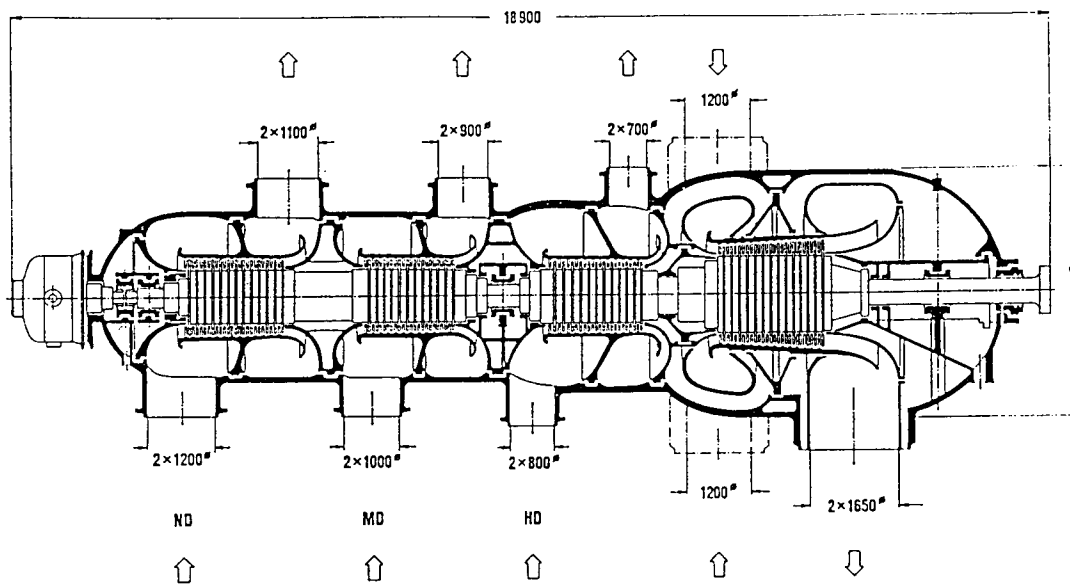

Figure 4 - Longitudinal Section Helium Plant Turbo Set 300 MW

## REFERENCES

- [1] Glaser, P.E.: Progress in Solar Power Satellite Development. Abstracts Solar World Forum, Brighton, England, 23-28 August 1981, Pergamon Press, pp. 634.
- [2] Oberth, H.: The Rocket into Interplanetary Space. Part III, Chapter 17, pp.87, Muenchen und Berlin 1923, Verlag R. Oldenburg (in German).
- [3] Oberth, H.: Man into Space. Chapter 5, pp. 125, Econ-Verlag, Duesseldorf, 1954 (in German).
- [4] Bammert, K.: Twenty-Five Years of Operating Experience with the Coal Fired Closed-Cycle Gas Turbine Cogeneration Plant at COBURG. Transactions of the ASME, Vol. 105 (1983), No.4, pp. 806/815.
- [5] Bammert, K., Deuster, G.: Das Helium-turbinen-Kraftwerk Oberhausen. Energie und Technik, No. 1/1974, pp. 1-6, L.A. Klepzig Verlag, Duesseldorf (in German).
- [6] Sutsch, A.G.: SEPP - Solar Energy Power Plant. Institute for Computer-assisted Research in Astronomy, December 1979.
- [7] Sutsch, A.G.: Advantages of Large Parabolic Dish Systems for Power Generation. Solar World Forum, Brighton, England, 23-28 August 1981, Pergamon Press, pp. 2951.
- [8] Bammert, K., Sutsch, A.G.: Electricity, Process Heat and Communication with Large Parabolic Dish Systems. Centro Euratom, Ispra, Italy, Contract 2080-83-03 ED ISP CH, 1983.
- [9] Bammert, K., Sutsch, A.G., Simon, M., Mobarak, A.: Small Gas Turbine with Large Parabolic Dish Collectors, ASME 81-GT-201.
- [10] Bammert, K., Seifert, P.: Design parameters for tube cavity receivers in solar power plants. Atomkernenergie/Kerntechnik, Bd.39, Nr.3 (1981) 163-173. Verlag Karl Thiernig, Muenchen.
- [11] Bammert, K., Twardziok, W.: Kernkraftwerke mit Heliumturbinen fuer grosse Leistungen. Atomkernenergie, 12.Jg (1967), Heft 9/10, Verlag Karl Thiernig, Muenchen (in German).
- [12] Deuster, G.: Die geschlossene Gasturbine - historische Entwicklung und zukuenftige Bedeutung. Atomkernenergie (ATKE), Bd. 32 (1978), Lfg.4, Verlag Karl Thiernig, Muenchen (in German).