

# NASA Technical Memorandum 80046

(NA A-TM-80046) OPERATIONAL BENEFITS FROM  
THE TERMINAL CONFIGURED VEHICLE (NASA) 57 p  
HC A04/NF A31 CSCI 01C

N79-17827

Unclass

G3/03 16311

## Operational Benefits from the Terminal Configured Vehicle

John P. Reeder, Robert A. Schmitz,  
and Leonard V. Clark

JANUARY 1979



**NASA**

National Aeronautics and  
Space Administration

Langley Research Center  
Hampton, Virginia 23060

**OPERATIONAL BENEFITS FROM THE TERMINAL CONFIGURED VEHICLE**

by

**JOHN P. REEDER, ROBERT A. SCHMITZ, and LEONARD V. CLARK**

**TERMINAL CONFIGURED VEHICLE PROGRAM OFFICE**

**NASA LANGLEY RESEARCH CENTER**

**HAMPTON, VIRGINIA 23665**

**ABSTRACT**

The NASA Terminal Configured Vehicle is a flying laboratory used to conduct research and development on improved airborne systems (including avionics) and operational flight procedures, with particular emphasis on utilization in the terminal area environment. The objectives of this technology development activity, focused on conventional transport aircraft, are to develop and demonstrate improvements which can lead to increased airport and runway capacity, increased air traffic controller productivity, energy efficient terminal area operations, reduced weather minima with safety, and reduced community noise by use of appropriate procedures. This paper discusses some early results of this activity in addition to defining present efforts and future research plans.

## INTRODUCTION

The NASA Terminal Configured Vehicle (TCV) Program is an advanced technology activity focused on improved operations of Conventional Takeoff and Landing (CTOL) aircraft in high density terminal areas with reduced weather minima. The purpose of the program is to address the improvement of airborne equipment and procedures in future high density terminal areas, considering advanced flight systems (primarily controls and displays) coupled with improved navigation, communication, and landing guidance. Part of this program is to assess the impact and interaction of these improvements with the air traffic system. The TCV Program is managed by the NASA Langley Research Center, and in cooperation with DOT/FAA and other NASA centers, is developing technology for advanced airborne systems and flight procedures to improve terminal area operations in the future ATC environment.

The urgency for improvement in terminal area operations is illustrated by the air fleet growth projections shown in figure 1 from (ref. 1). One of the major constraints on capacity is the delay and congestion in the terminal area, and this situation will only worsen if the fleet growth occurs as shown in the figure. An actual data point is shown on the chart which indicates a larger fleet than predicted in the 1970 forecast. Conservative estimates indicate a doubling of the air fleet by 1995.

Withington of Boeing (ref. 2) estimates that a 5% reduction in delay (or flight time) is equivalent, in terms of direct operating costs (DOC), to a 5% reduction in drag. Figure 2 illustrates this point, with an approximate 3.5% change in DOC associated with drag and a 3.2% change in DOC associated with flight time reduction.

Considering the cost of delays, let us examine the lower part of figure 3, which is discussed in more detail in (ref. 3). The schedule time of an airline flight of average stage length is shown, including the various components (shaded) that add to the time required for a direct flight with no delays. Although the passenger is not aware of any delays, the average delays due to non-direct routing (current airway routes vs direct routes), holding and path stretching to obtain aircraft separation, non-optimum altitudes, weather delays, etc., are included in the airline scheduled flight times. In this particular case, 25% of the time is built-in for delays. It is estimated that a 20% reduction in scheduled time for a Boeing 727 of the stage length illustrated could be realized through improvement in airspace utilization of the type the TCV Program is investigating. This equates to approximately a 13% reduction in DOC. A more disturbing illustration of deteriorating airspace usage is presented in the upper part of figure 3 where a current jet time

schedule is compared with an earlier turboprop flight time. The schedule time for the jet, which always follows Instrument Flight Rules (IFR) and procedures, is 42% greater than the slower Lockheed Electra using a direct routing under Visual Flight Rules (VFR). An objective of the TCV Program is to improve future systems to approach the VFR-type of operation in Instrument Meteorological Conditions (IMC).

A more alarming trend is shown in figure 4. This shows as a function of time the number of major air carrier airports in the United States that have reached or will reach practical capacity (15 minutes peak-hour delay) in IMC if nothing is done to improve the air traffic system. Note that in 1974 nine airports had already reached practical capacity. The number of such airports is forecast to increase rapidly until about 1984, and then increase at a lesser rate, reaching 24 such airports by the year 2000. If this is allowed to happen, the growth of air transportation will become seriously inhibited. Major improvements will require extensive research and development and a long lead time to implement.

This lead time in the past has been considerable. To emphasize this point, let us examine in detail figure 5. It can be readily seen that it has been almost 50 years since Doolittle made his blind landing, and 34 years since the first successful automatic landing in a transport aircraft. Today, CAT III operations (approaching zero visibility) carrying fare-paying passengers, has barely begun in this country while CAT II is not yet implemented fleet wide. Figure 5, overlaid by figure 4 shows that on a calendar time basis the MLS development and implementation is late with regard to overcoming IMC capacity limitations. Also, the development of new airborne equipment and procedures to take full advantage of the MLS, as well as other planned new airspace systems, may well lag behind the airspace systems development. It will be a miracle if such advanced ground and airborne systems are functioning operationally on a broad basis before 20 years have elapsed, unless an intensive and continuing effort is made toward necessary improvements.

The NASA Langley Research Center, in cooperation with the FAA, is pursuing research and technology development for airborne systems and procedures that can provide needed improvements for the anticipated air traffic problems. The concept of this program, the Terminal Configured Vehicle (TCV) Program, is illustrated in figure 6. The future terminal is envisioned as one in which arrivals may be scheduled to outer fixes from which metering and spacing to the runway is accomplished in terms of time.

This paper discusses the TCV Program, including the TCV aircraft facility, and the operational benefits measured by research experiments as well as demonstrations of the U.S. Time Reference Scanning Beam Microwave Landing System (TRSB MLS). Other research activities, present and future, are also discussed.

### THE TCV PROGRAM

It is recognized that to take advantage of new air traffic systems to solve the problems they are intended to solve, a similar advance in the airborne systems and flight procedure capability must be achieved. The airborne system is considered to be the basic airframe and equipment, the flight-control systems (automatic and piloted modes), the displays for pilot monitoring or control, and the crew as manager and operator of the system. Because of the urgent need to develop the required airborne system capability, the NASA Langley Research Center has implemented a long-term research effort known as the Terminal Configured Vehicle Program, first described in (ref. 4). The TCV Program purpose is to identify aircraft system and flight management technology that will benefit terminal area operations of conventional aircraft. The major research objectives to achieve this goal are:

- (1) Improve Terminal Area Capacity and Efficiency
  - a. Systems and procedures for ATC evolution
  - b. Systems and procedures for runway capacity
  - c. Profiles and procedures for fuel conservation
- (2) Improve Approach and Landing Capability in Adverse Weather
  - a. Human factor elements for effective flight management
  - b. Systems and information to minimize wind-shear hazard
  - c. Airborne sensors for weather penetration
- (3) Reduce Noise Impact through Operating Procedures (Profiles and Configurations for Noise Reduction)

In order to accomplish the Program objectives and goal, a balanced flight system is required with research activities being conducted in automatic controls, displays, and airframe characteristics. Displays and controls are considered essential for full participation of the pilot in the navigation and control of the aircraft in the terminal environment. Automatic control is considered as augmenting the piloting functions in the execution of safe and efficient flight.

## TERMINAL AREA IMPROVEMENTS

Operational goals of the TCV Program are illustrated in figure 6. A microwave landing system providing precision navigation signals throughout a large volume of airspace is considered an important element of the advanced airspace system. As seen in this figure, operations in the MLS environment can, with proper controls, displays, and airframe characteristics, enable more effective airspace utilization. This can lead to alleviation of noise over heavily-populated areas, and to a reduction in flight time and fuel consumption. Also, on-board precision navigation and guidance systems, with displays, will allow 2-dimensional (2-D), 3-dimensional (3-D), and 4-dimensional (4-D, which includes time) navigation for closer sequencing and lateral runway spacing for simultaneous instrument approaches. Finally, programmed turnoffs at relatively high speeds are required to clear the runway to allow operations to proceed with perhaps 40 to 45 seconds between aircraft, assuming alleviation of vortex wake problems and greatly reduced touchdown dispersions. Research on displays and controls is underway with the intent of achieving more efficient operations in lower visibility conditions with sufficient confidence that they become routine.

The primary facility used in the flight research is a highly modified Boeing 737 aircraft (figure 7) equipped with all-digital, integrated navigation, guidance, control, and display systems which can be readily reprogrammed for research purposes. A simplified block diagram of the flight control system that now exists is illustrated in figure 8.

## THE TCV B-737 AIRCRAFT

A cut-away view of the aircraft, shown in figure 9, illustrates the palletized installation of the avionics, and depicts a second cockpit for research (aft flight deck, AFD). Research is enhanced by several notable design features:

- (1) The system functions are controllable and variable through software.
- (2) The hardware is easily removed, modified, repaired, and installed.
- (3) Flight station changes are readily accomplished in the research cockpit, which has a fly-by-wire implementation for control of the aircraft.

The arrangement of the AFD is shown in the photograph of figure 10. The center area of the cockpit is seen to resemble a conventional B-737 cockpit, whereas the area immediately in front of the pilot and co-pilot have been opened up by removing the wheel and column and replacing them with "brolly handle" controllers. These "brolly handles" allow control of the aircraft from the AFD through either one of the two "fly-by-wire" control wheel steering (CWS) modes. The open area between the "brolly handles" has been utilized for locating advanced electronic displays.

The displays illustrated in figure 10 consist of an electronic attitude director indicator (EADI) at the top, the electronic horizontal situation indicator (EHSI) in the middle and the navigation control display unit (NCDU) at the bottom, one set for each pilot. A control mode select panel is shown located at the top of the instrument panel and centered between the two pilots. This panel allows selection of CWS control modes, or 2-D, 3-D, or 4-D automatic flight. The NCDU is used to enter preplanned routes and profiles, to call up route and flight profile information for review and/or for entering new or revised information. Also, flight progress information can be called up on the NCDU for review.

The EADI instrument provides basic attitude and vertical path information to control the aircraft. The EADI symbology is explained in figure 11. The EHSI, illustrated in figure 12, is a pictorial navigation display to provide the pilot with accurate aircraft situation information relative to the guidance path desired (either INS or MLS RNAV derived), flight plan waypoints, and geographic points of interest such as airfields, mountains, and VORTAC's. The dotted track select line is a tentative new track and becomes solid when acquired in manual flight or accepted through the NCDU for automatic flight. In the illustration the desired horizontal flight path is displayed as a solid line connecting waypoints. The curved trend vector shown emanating from the nose of the aircraft symbol consists of 3 dashes indicating future position at 30, 60, and 90 second intervals. Only a 30-second trend vector is displayed with the 1 n. mi. scale. A rectangular box, just beyond the waypoint SOUND, indicates the scheduled along-path position during 4-D operations, with the dots ahead of it indicating future scheduled positions at 30, 60, and 90 seconds. The time box location in figure 12 provides the pilot with an indication of his scheduled time and flight path position errors.

Magnetic track is indicated at the top of the EHSI. The operating modes of the two EHSI's (pilot and first officer) are independent; i.e., one may be operated in the north-up mode (for route visualization) and the other in track-up (preferred for navigation); they may also be operated with different map scales or options. The six map scales provided are 1, 2, 4, 8, 16, and 32 n. mi./inch, and the one selected is

displayed in the lower left corner of the EHSI. The altitude/range symbol, an option when in the track-up mode, consists of an arc some distance ahead of the aircraft symbol which represents where the aircraft would reach the reference altitude, selected via the control mode select panel, if the current flight path angle is maintained. In the lower right corner of the EHSI are displayed the ground speed (GS) in knots, the mode of navigation (in this case inertial with single DME update, IDX), and the wind direction and velocity. When in the MLS RNAV mode the letters AMX (for air data, MLS update) would appear in the lower right corner.

Complete flight from takeoff through landing can be accomplished from the AFD.

#### U. S. MICROWAVE LANDING SYSTEM

In April 1978 the International Civil Aviation Organization (ICAO) All-Weather Operations Division is scheduled to vote for selection of a new international standard approach and landing guidance system that will replace both the current instrument landing system (ILS) at civil airports and the ground controlled approach (GCA) at military airports. An All-Weather Operations Panel selected by the ICAO All-Weather Operations Division evaluated candidate microwave landing systems (MLS) submitted by Australia, the United Kingdom, France, West Germany and the United States. This panel recommended for international adoption the U.S. Time Reference Scanning Beam (TRSB) MLS. All candidate systems operate at microwave frequencies and are designed to serve the needs of all aircraft for operations in all-weather conditions.

The U.S. candidate TRSB MLS basically transmits three time-reference scanning fan-shaped radio beams from the runway, as illustrated in figure 13. The azimuth beam scans from side to side of the runway center  $\pm 60$  degrees or  $\pm 40$  degrees, depending on configuration, at a rate of  $13\frac{1}{2}$  times per second to provide azimuth (Az) referencing. The second beam scans up to 20 degrees and down to a reference plane parallel to the runway surface at a rate of 40 times per second to provide basic glide path guidance (EL1). The third beam, which scans up  $7\frac{1}{2}$  degrees and down to the same plane parallel to the runway at a rate of 40 times per second, is used for flare guidance (EL2). A fourth nonscanning fan-shaped beam transmitted from a distance measuring equipment (DME) site provides ranging information. This DME beam is transmitted at a rate of 40 times per second and has an angular coverage of 120 degrees in azimuth and 20 degrees in elevation. Time reference means that receiving equipment on board the aircraft will measure the time difference between successive



"to" and "fro" sweeps of the scanning beams to determine aircraft position relative to the runway centerline and to a preselected glide path. This time difference measurement technique gives rise to designation of the U.S. MLS as a Time Reference Scanning Beam MLS.

### NASA SUPPORT OF FAA IN MLS TEST/DEMONSTRATIONS

Early in the TCV Program, a joint NASA/FAA agreement recognized the long-term objectives of the NASA Program, and NASA agreed to provide use of the TCV aircraft for support of specific FAA system evaluations, including that of the MLS. In July 1975, at the request of the FAA, NASA agreed to participate in a flight test/demonstration of the U.S. TRSB MLS capabilities to the All Weather Operations Panel (AWOP) of ICAO at the FAA's National Aviation Facilities Experimental Center (NAFEC) in May 1976. The ground rules adopted for the demonstration were:

- (1) Fly 3-D automatic curved, descending approaches using the originally implemented navigation control laws for the curved-path portions and using MLS guidance instead of inertial platform (INS) guidance when within the MLS coverage.
- (2) Make transition from curved-path portions to short, straight final approaches and land with the original autoland laws modified to use MLS guidance substituted for INS and ILS guidance. (This implies delivery by the area navigation (RNAV) system {using MLS} into a narrow wings-level window aligned with the final straight-in course to permit "capture" by the autoland system.)
- (3) Perform flares using EL2 and/or radio altimeter signals.
- (4) Perform roll out using MLS guidance.
- (5) Modify the electronic displays to accept MLS derived information. These displays include (a) horizontal situation, (b) curved trend vector, and (c) centerline and glide path deviations.

All the capabilities implied by the ground rules were to be tested and demonstrated in an automatic mode without use of the inertial smoothing technique which is a basic part of the original configuration in the TCV aircraft. The FAA asked that no acceleration signals be used to augment the MLS data, if possible. However, the FAA stated that the use of body-mounted accelerometers or direct measurement of INS acceleration signals were permissible if parameters of this type were needed for the basic control system. The FAA also stated that the use of attitude data

from the INS was permissible, in lieu of attitude from additional high-quality vertical and directional attitude reference systems, for control/display purposes. The philosophical approach taken by Langley Research Center was to make minimum modification in the existing navigation, guidance, and control systems and to derive all necessary parameters from the MLS data for interface with these systems.

Following the NAFEC tests/demonstrations in May 1976, the FAA, in early September 1977, requested further test/demonstration support of NASA with the TCV aircraft. The tests/demonstrations were to be at Buenos Aires, Argentina, during October - November 1977; New York's Kennedy Airport in November - December 1977; Montreal, Canada, in March - April 1978; and NAFEC again on a more relaxed schedule during early summer 1978. The latter is to be in the context of research experiments with the use of back azimuth and C-band flare antennas as new experiments.

Although improvements have been made during the course of these tests/ demonstrations to the automatic mode performance, and to the longitudinal control and EADI display for piloted Control Wheel Steering (CWS) operations, the basic avionic configuration for utilization of the MLS signals has remained the same. At this time the tests/demonstrations at Buenos Aires, New York, and Montreal have been completed successfully.

#### AVIONICS CONFIGURATION FOR ICAO TEST/DEMONSTRATION

The basic configuration of the TCV B-737 flight control system was shown in figure 8. The flight critical sensors and computers for the autoland system are triplicated for redundancy, similar to those that would be suitable for an operational system. Other components were intended to be dualized, but have not been in the current research system. The TRSB MLS integration with the TCV aircraft flight control system is illustrated in figure 14 from (ref. 5). As noted, the original avionics system was not configured to use MLS data for navigation, guidance, or control.

The principal task to which NASA addressed its efforts was the integration of the MLS signals into the navigation, guidance and control laws and display symbology of the original system that had been designed to use INS, DME, ILS, and radio altimeter data. The major development efforts involved with the configuration, as shown in figure 14, were directed at aircraft antenna design and location, interface of the MLS receiver with the experimental system, and design of the MLS guidance signal processor. Wherever possible, the functions of this signal processor were designed to permit integration of MLS derived navigation,

guidance and control parameters with existing laws of the navigation and guidance computer and the flight control (autoland) computer with minimal modifications to these computers. Minor changes were made to the existing display formats with features added to indicate validity of MLS signals and to improve the perspective runway format.

### FLIGHT PROFILES SELECTED

The flight profiles selected for the 1976 ICAO tests/demonstrations are shown in figure 15 superimposed on a photograph of the NAFEC area. The two profiles shown in this figure are designated as a 130-degree azimuth capture and an S-turn azimuth capture. Each flight profile contains a 3 n.mi. straight final approach representative of many VFR approaches being flown at the present time at congested airports near heavily populated areas. These profiles, which can be used to provide alleviation of noise over populated areas, are also illustrative of the types of curved paths that have potential for increasing airport capacity in an advanced ATC environment.

A more detailed description of flight events along the demonstration profiles is given in figures 16 and 17. As seen in figure 16, for the 130-degree azimuth capture, takeoff was from runway 04 with the aircraft controlled manually from the front cockpit where a control wheel steering (CWS) mode was selected by the AFD pilot. Prior to encountering the first waypoint, the AFD pilot selected a 3-D automatic RNAV mode for aircraft control. This control mode used inertially smoothed DME/DME (IDD) as the source of guidance information. Altitude was maintained at 1220 m (4000 ft) until the waypoint indicated by "Begin 3-degree "Descent" was reached. From this point the aircraft continued descending at 3 degrees until flare was initiated. After crossing the MLS Az boundary and approximately 15 seconds after crossing the EL1 boundary, the pilot received an indication of valid MLS data, at which time he selected the MLS RNAV mode which used MLS data as the source of guidance information. This latter event is noted as "MLS Enable" in figure 16. Just prior to entering the final turn, the pilot switched to "Land Arm". The aircraft continued to fly under the MLS RNAV mode until both selected glide path and lateral path were acquired; then the control of the aircraft automatically switched to autoland, which then controlled the aircraft along the 3 n.mi. final approach. At an altitude consistent with the sink rate and altitude criteria of the flare laws in the flight control system, flare was initiated. Flare was executed using EL2 and DME data as the source of vertical guidance information on most of the touchdowns. On a few flights during the demonstration, a radio altimeter was used as the source of vertical guidance information for comparison purposes.

100 events along the S-turn profile are very similar to the events of the 130-degree azimuth capture profile, as shown in figure 17. It may be noted that the S-turn profile resulted in greater time period of MLS RNAV than did the 130-degree profile. On touch-and-go approaches, control was switched from aft flight deck automatic control to front flight deck manual control for the takeoff portion of repeat flights. On landings that continued to a full stop, roll out was conducted in an automatic mode that used the Az beam for runway centerline guidance information.

## FLIGHT RESULTS

During the development, test/demonstration, and post-demonstration data-collection flights in the NAFEC MLS environment, 208 automatic approaches and 205 automatic flares were flown. These flares were terminated in touch-and-go maneuvers and full-stop landings that included automatic roll out operations. During these flights, final approaches of 3 n. mi. were achieved. Following the formal demonstration, shorter-final automatically controlled approaches of 2 n. mi. were flown using acceleration data from body-mounted accelerometers instead of from the INS. No degradation in performance was noted. Manually controlled flights from the AFD, conducted after the formal demonstration, included 41 approaches with final segments of 3, 1.5 and 1 n. mi.

During these flights, the NAFEC phototheodolite tracking system was employed to optically track the aircraft during the final approach phases. Position information in an orthogonal coordinate system with origin located at the center of the MLS azimuth antenna array was derived from tracking elevation and azimuth angles from at least two, and usually three, phototheodolite tracking towers. These data were digitally filtered to reduce the noise level of the position information. The sample rate of the theodolite data is 10 position samples per second. The accuracy of position determined from the theodolite system was considered to be about 1 m at 3 n. mi., and about 0.3 m at the runway threshold.

Statistical summary plots from (ref. 6) of vertical and horizontal errors for the final approach measured by theodolite system for the 53 automatic approaches performed during the 1976 formal demonstration are presented in figure 18. The errors at 5 to 6 km from touchdown are those incurred by the navigation system at the end of the final turn before capture by the autoland system. The "jump" in the data at 5 km is due to switching from radar tracking to theodolite tracking.

The mean overshoot error on turning onto final was about 9 m, tapering down to about 3 m at 1 n. mi. The mean vertical error at 1 n. mi. was less than 1.5 m. This accuracy of performance was achieved despite very adverse winds. The winds were strong and gusty and quartering from the left rear, thus providing strong crosswind and tailwind components that were larger than those considered in normal autoland certification. Very strong shears were also experienced at times. A more detailed discussion of the flight performance during these 1976 flights is contained in (ref. 6).

#### DISPLAY UTILIZATION IN PRIMARILY AUTOMATIC FLIGHT

In exploiting the MLS capabilities in an RNAV and MLS environment, and in utilizing profiles such as those demonstrated before the ICAO, it is essential that the flight crew be continually oriented with respect to its flight and navigation situation. Today's aircraft flight instrumentation is not considered operationally adequate, either for monitoring automatic flight or for contingency reversion to manual control in the environment anticipated; that is, close-in, curved, descending, precision approach profiles with very low visibility and close proximity to other traffic. Consequently, the advanced electronic display system has been provided on the aft flight deck of the TCV aircraft with which to explore and develop this all-important interface of the pilot with his environment.

During the formal ICAO demonstrations, the ability to observe the position of the aircraft at all times and its tracking performance by means of the displays was as impressive as the automatic operation itself, as indicated in (ref. 5). After takeoff, the displays permitted the AFD pilots to position the aircraft manually for a smooth, maneuverless transition to 3-D automatic flight into the first waypoint of the automatic profile. Also, during the development flights prior to the demonstration, numerous interruptions in flying the profiles were encountered. Several diversions due to intrusion of traffic were encountered, and there were many programming errors and malfunctions of various kinds that led the pilot to take over. The displays, in combination with control wheel steering, resulted in effortless navigation during reprogramming or redirected flight and facilitated expeditious maneuvering by the pilots to reenter the desired patterns without lost time or excessive airspace for orientation and without the need for vectoring from the ground. The EADI symbology provided an effective means of monitoring

flight progress on final approach. In particular, the excellent registration of the computer-generated image of the runway with the real runway (as shown by a superimposed TV image of the real runway) established confidence in the potential utility of computer-generated runway symbology for monitoring landing operations.

The implications for the future are clear with respect to automatic flight. Advanced displays will have to be provided to:

- (1) Maintain crew orientation
- (2) Permit manual maneuvering within constraints in airspace, fuel and time in order to cope with diversions due to traffic or weather, or loss of automatic capability.
- (3) Permit continued controlled and accurate navigation when new clearances and/or flight profiles must be defined.

#### MANUALLY CONTROLLED APPROACHES

Upon completion of the automatic flights of the 1976 ICAO demonstration, additional flights were conducted to evaluate display effectiveness for manually controlled flights along the same profiles, since this is considered to be the best way to evaluate display information for monitoring purposes and take-over if necessary. This work is reported in (ref. 7 and 8).

The velocity-vector control mode was used during the approaches. In this mode the pilot commands pitch rate by pulling or pushing the panel-mounted controllers. When the pilot perceives that the desired flight path angle has been reached, he releases the controllers and the system maintains that flight path angle regardless of changing winds or airspeed. The pilot also commands roll rate by rotating the panel-mounted controllers. When he attains the desired track angle relative to the runway, he releases the controllers with wings level and that track angle is maintained until further inputs are made, regardless of varying winds.

First, in the evaluation of the display, comparative performance tests were made between a baseline display format, consisting of the EADI and EHSI, as shown in figure 19 and an integrated display format shown in figure 20. The integrated display concept has a computer-generated perspective runway and relative track information added to the EADI symbology to bring horizontal situation up into one display. This

improves the realism of the display format and reduces the scanning and mental integration required in the two-display arrangement. However, the pilots required 2 or 3 sessions using this display in simulation before learning how to use it effectively.

The task designed for the test consisted of flying a path offset 0.1 n. mi. inside the 130-degree turn approach, as shown in figure 21. At the end of the turn the offset was removed and the pilot had then to acquire and track alignment with the runway in the 3 n. mi. remaining to flare height. Three pilots took part in the test. Figure 22 shows the tracking performance with the baseline format. Note that the pilots did not, in this case, align or stabilize the flight path adequately with respect to the runway before crossing the threshold. Using the integrated display, adequately stabilized alignment was achieved at a comfortable distance from the threshold as shown in figure 23.

Evaluation of the integrated display format was continued with the task of performing the 130-degree profile with final approaches shortened to 1.5 and to 1 n. mi. Four pilots took part in these tests. These were the first such approaches flown by the pilots. Figure 24 shows tracks for a 1.5 n. mi. final and indicates stabilized alignment again at a comfortable distance from the threshold. The large overshoot of about 100 m on one approach was not of concern to the pilot because his situation was clear to him and he proceeded to acquire runway alignment without overshoot or undershoot. Figure 25, for a 1 n. mi. final, indicates that the pilots did not do as well in stabilizing alignment as with longer finals, but probably did an adequate job for suitable landings to be accomplished with visual references.

A summary of the curved approaches, both automatic and manual, accomplished at NAFEC in 1976 are shown in figure 26. Note that for the 130-degree automatic approach a spread of paths is indicated prior to entering the full MLS coverage. This spread is indicative of the errors incurred by the normal RNAV system (INS with DME/DME update, or IDD) before entering the MLS coverage. When MLS guidance is enabled and the INS is replaced by more accurate MLS guidance a transition maneuver is required to acquire the desired MLS path. Should the final approach be reduced to 1 n. mi., as indicated for the manual approach data of figure 26, and particularly, if a 180-degree turn from a downwind leg should be desired (as for VFR flight), the transition maneuver into MLS paths could interfere severely with the turns. Thus, it is obvious that for close-in turning approaches that might be desired in the future the minimum MLS azimuth coverage should be more nearly  $\pm 90$  to  $\pm 120$  degrees than  $\pm 60$  degrees. The RNAV to MLS transition maneuver itself is under study to determine how best to perform such maneuvers in various situations.

## BUENOS AIRES TEST/DEMONSTRATION

The TRSB MLS test/demonstration in Buenos Aires from October 31 through November 7, 1977, was for the attendees of the Inter-American Telecommunications Conference of the Organization of American States (OAS) as well as other invited representatives of the OAS, local Argentine officials and the press.

The test operations were conducted at Aeroparque Jorge Newbery, a single strip downtown airport 4 km from city center) which handles a high volume of short haul and commuter traffic. This airport lies along the shore of the Rio de la Plata.

The MLS configuration the FAA chose for the Aeroparque installation was the Basic Narrow (aperture) with  $\pm 40$  degrees azimuth coverage. This was installed on runway 13. No flare antenna (EL2) was provided. Ground tracking data of the approaches have not been obtained. On-board recorded tracking data have not yet been completely processed.

The two NASA approach patterns (STAR's) chosen for the test, ABE04 and ABE05, are shown in figures 27 and 28. Both patterns began at an altitude of 914 m (3000 ft) over the river at about 5 n. mi. laterally from the touchdown position. The 3-degree descent began at the initial waypoint. ABE04 required a 90-degree turn into a 3 km (1.6 n. mi.) straight final and about  $3\frac{1}{2}$  minutes to complete from the initial waypoint, whereas ABE05 required a 60-degree turn into a 2 km (1.1 n. mi.) final and  $3\frac{1}{4}$  minutes to complete from the initial waypoint. The logic for the patterns chosen can be deduced by noting in figure 29 that these approaches are over the river until the end of the final turn, thus minimizing noise exposure to heavily populated areas that lie under the long straight-in ILS approach. During all flights an FAA controller manned the tower and handled communication with the TCV aircraft. Flight periods were scheduled between 11 a.m. and 5:30 p.m., for traffic reasons. Generally, two flights per day with 10 observers per flight were conducted. Five approaches were planned per flight, four of ABE04 and one of ABE05, with touch-and-go landings between approaches. On several flights, traffic delays reduced the number of approaches to between one and three since no priority was given the TCV aircraft over airline flights.

After takeoff the aircraft was turned and flown from the AFD using the velocity vector control wheel steering mode and was positioned for the first waypoint and automatic 3-D flight initiated. The 3-degree descent began under automatic control at the first waypoint. As explained earlier, the TCV aircraft RNAV system, in its normal mode, is based on



an inertial system (LTN51) with primary update from DME/DME (dual DME or D-DME). DME's are rare in South America. Only one existed in the area, that at Ezeiza International Airport where the TCV aircraft was based, some 16 n. mi. from Aeroparque. The update had to revert to that of a single DME, a much less accurate mode.

The error accumulated during the described pattern procedures in this update mode was significant by the time the TRSB MLS coverage was entered, resulting in fairly large offsets and vigorous maneuvers to acquire the desired STAR track.

If holding was required, the errors became significantly larger, and could lead to an aborted autoland. With STAR ABE04 there was less than a mile under MLS guidance before the final turn entry with the MLS Az coverage provided. If the error was to the east of the track, the offset corrective maneuver to the right, because of proximity to the final turn, tended to cause the aircraft to overshoot the runway alignment outside of capture limits, followed by slow correction back until capture.

For the formal demonstrations, when holding the pattern was arranged to fly into the MLS coverage on each circuit to obtain the RNAV update. This technique reduced the navigation and offset errors significantly. With the ABE05 STAR, the distance from entrance into the MLS coverage until start of the final turn, was greater than ABE04 so that the RNAV-INS transition maneuver could be completed before entrance to the final turn. Winds during the demonstrations were light to moderate except for one day with about a 35 knot, 45-degree crosswind from the left at ground level. This wind was blowing across tall trees on the approach, and on one approach an abrupt left wing drop of 15 degrees about 30-45 m (100-150 ft) altitude followed immediately by an abrupt right wing drop of 15 degrees. The automatic approach continued, nevertheless, to a successful autoland. Altogether, 56 autolands and automatic roll outs were accomplished at Aeroparque. During actual formal demonstration flights, 42 autolands plus 1 manual takeover landing were performed. The takeover resulted from failure to achieve autoland capture. In time, digital control laws will be developed for use throughout the MLS coverage in the precision autoland mode to avoid this capture problem. As before, the pilot's displays in the AFD impressed the observers most, particularly the pilots, both airline and military. During the development flights and ferry flights from Ezeiza (base airport) to Aeroparque for the demonstrations, the pilots performed a few complete STAR profiles manually from the AFD using the displays. Noteworthy was the fact that three of these were carried through landing and roll out using the integrated display

format discussed earlier and shown in figure 20. One additional landing from the AFD was made using TV camera "imagery" superimposed on the basic symbology (i.e., no computer generated runway). These were all low-rate-of descent, on-centerline landings.

These landings were greatly aided by application of recent TCV research into longitudinal control and display integration. The research program has been conducted through analysis and simulation, treating the longitudinal control and the flight path angle symbology of the vertical situation display (EADI) as a single system. The aircraft longitudinal response time with respect to control column inputs was reduced and damping increased through appropriately tailored elevator rate and displacement using fly-by-wire control and stability augmentation. At the same time, a predictive flight path angle symbology responded immediately to column commands, with actual flight path angle symbology following the predicted value very quickly and without overshoot. Thus pitch control and displays were linked in a quick response, highly damped system which vastly improved the ability to track as well as to fly accurately through a flare maneuver. A report on this work is in preparation. However, judgement of height through the current generated runway symbology is not considered totally adequate for flare in an operational sense. Work to improve such displays is continuing.

A report on the tracking performance of the aircraft in the automatic mode during these tests/demonstrations is in preparation.

#### JFK TEST/DEMONSTRATION

Following the Buenos Aires operation, TRSB MLS test/demonstrations were conducted at J. F. Kennedy (JFK) Airport in New York from December 5 through December 13, 1977. These operations were for airline personnel, local and state aviation officials, congressional observers, international observers, the press and television.

The TRSB MLS configuration provided at JFK was a basic Wide (aperture) with  $\pm 60$  degrees azimuth coverage. The MLS antenna were set up for runway 13L. No flare antenna was provided. No ground based tracking data have been obtained by the NASA at this date.

The Canarsie approach into JFK, an effective noise abatement procedure, is shown as a published approach profile in figure 30. The approach is performed only under visual conditions with a 244 m (800 ft) ceiling and 2 n. mi. visibility minima. The visual portion of this approach is defined by high intensity flashing lead-in lights on the ground which

generally follow Shore Parkway. This approach avoids high density residential areas and saves airspace and time. This approach procedure makes an excellent case for an MLS volumetric coverage precision guidance system to allow similar approaches under instrument meteorological conditions. The significance of being able to perform such close-in patterns during instrument flight conditions is obvious from figure 31 showing the New York terminal area for a typical landing direction. The ILS patterns for the several airports overlies one another's control zones (shown by dashed outlines).

There is no usable airspace between the control zones in this case. If one could use Canarsie-type approach patterns as depicted, under IMC, the approach patterns could be contained within the individual control zones, thus freeing airspace for short-haul or other traffic use between control zones and alleviating some of the traffic conflict and capacity problems of the major airports.

The test/demonstration profile chosen was an overlay of the published Canarsie approach to runway 13L shown in figure 30. Figure 32 shows the TRSB MLS approach in detail from Canarsie VOR (CRI) inbound. A constant 3-degree glide path was followed. The dashed line indicates the MLS azimuth coverage provided. The turn is a constant radius of 4,500 m and requires a very shallow average bank angle of about 8 degrees. The straight-in portion was only 0.44 n. mi to the displaced threshold.

It is of interest that, particularly during the development period prior to the demonstrations, local ATC controllers from the common IFR room and the tower at JFK were carried on each flight. The controllers, as a result, became enthusiastic in support of the advanced experiment. The displayed situation information, particularly, impressed the controllers. FAA personnel with ATC experience from Washington Headquarters and NAFEC were also assigned to the common IFR room and tower to advise and assist local personnel during the JFK flights. Having enlisted the enthusiasm of the local controllers, a departure/arrival RNAV pattern, shown in figure 33, was mutually agreed on that was expeditious and predictable in terms of time, and was specific and accurate in terms of track. The navigation after takeoff was thereafter left up to the NASA crew, with radar following. The aircraft capability and ATC cooperation, after the controllers became familiar with the program and equipment, greatly expedited the demonstration flights. Generally, because of traffic, landings were full stop with takeoff in the opposite direction on runway 31R.

Strong tailwinds of the order of 20 knots or more occurred on 5 of the 8 demonstration days. A total of 45 autolands were accomplished during the whole exercise. Thirty approaches performed during the formal demonstration flights resulted in successful autolands, which was considered very successful under the circumstances. Eight approaches required takeover for manual landings. These results are attributed to the strong northwest winds at 20-30 knots, changing from a crosswind to a tailwind during the final turn, combined with the narrow autoland capture limits very close to the threshold. This illustrates the limitations of the ILS-type capture techniques currently implemented. Examples of on-board recorded tracking data from typical approaches are illustrated in figures 34 and 35. It is apparent that MLS RNAV lateral tracking errors generally did not exceed 12 m during the turn onto final approach, and were reduced to 3 m or less in the autoland mode. The vertical path errors in the MLS RNAV mode were about 6 m prior to autoland capture and about 3 m after capture. A report on aircraft automatic tracking performance during these flights is in preparation.

During the early development flights at JFK one manual approach using CWS was performed from the AFD. The pilot wished to assess the adequacy of the computer generated runway symbology for close-in runway alignment. The pilot overshot the runway centerline so that a successful recovery maneuver for landing could not be comfortably accomplished using the displays. The forward flight deck pilot took over for a successful maneuver and landing. However, the pilot who attempted the manual approach from the AFD believes the difficulty lay with the lateral control system characteristics and to a lesser degree, with the display itself. It is planned in the near future to improve the lateral control system for more precise use of the display system capabilities, such as was done for the pitch axis.

#### SUMMARY OF CURVED APPROACHES WITH TRSB MLS

A summary of the flight profiles flown under automatic control as well as in manual control modes during the NAFEC, Buenos Aires and New York operations is shown in figure 36. The approaches were, in the order listed above, increasingly more difficult in that the curved paths were carried closer to the runway before alignment. The accuracy of the MLS was high, and the aircraft performance good, considering the unfavorable winds encountered and the lack of full development of the automatic control techniques and control laws for utilization of MLS.

## PILOT/OBSERVER REACTION TO MLS PROFILES

During the course of the TRSB MLS development flights and demonstrations with the TCV B-737 aircraft over 400 automatic landings and roll outs from curved approach paths have been performed. Also, more than 700 observers have been carried during the actual demonstrations. The large majority of those coming off the flights appeared impressed and enthusiastic about the displays in particular, and the observations of the profiles from the front cockpit as well as the cabin seats. The profiles flown have all been generally acceptable and comfortable from the pilots' and observers' standpoint and have drawn no unfavorable comments. The MLS profiles have actually involved milder maneuvers than those experience in visual flight. The most vigorous maneuvers encountered to date have been those immediately following "MLS enable" at which time transition from normal RNAV to MLS RNAV occurs. These have not been abrupt, but are surprising, and their magnitude depends on the RNAV error incurred. These maneuvers do have to be prompt, necessarily, to eliminate the flight path error before it becomes critical for the final approach.

### 4-D TEST/DEMONSTRATION

In the future, 4-D (time controlled) flights will be required for controlling the arrival and landing of traffic at major airports in a sequence that will expedite the flow of traffic for maximum capacity. It seems probable that 4-D control, the basis for strategic control concepts, will be exercised from takeoff through landing with adjustments to arrival times being made en route and with fine tuning being applied in the metering and spacing to the runway threshold. The latter phase, from cruise through descent to the runway, is discussed in the following paragraphs on Metering and Spacing.

Limited flight tests have been made over a demanding one-hour test pattern using radar tracking to determine the magnitude of errors with the navigation system, including the time axis. These tests are described and some results for the automatic mode published in (ref. 9). For the normal mode of navigation with the inertial system using dual DME update, the results indicate that the mean time error to be expected at any way point (where ground speed has been specified), including the outer marker on arrival (or equivalent), is 1.4 seconds with a 0.7 second standard deviation. Further, 4-D flights to landing have shown typical errors of 3-5 seconds, the difference from the test pattern errors quoted being due to the fact that the final approach, being controlled

with respect to airspeed, is subject to wind effects. Errors at low elevations may also increase due to loss of dual DME update in some areas.

In the summer of 1977 a 4-D flight demonstration was performed by NASA for a small group of visiting Air Force (WADC), airline, Congressional staff and magazine personnel. The flight was from Langley into North Carolina and return for an ILS landing at Norfolk, a total distance of 259 n. mi. The flight had a scheduled landing time. Immediately after takeoff from Langley the aircraft was placed under 4-D automatic control. The major portion of the flight was accomplished automatically except for a maneuver to illustrate manual control capability in the 4-D mode as discussed in (ref. 10). During the flight leg from waypoint LVL to RMT, as illustrated in figure 37, a 6-minute delay in scheduled arrival time was simulated. Using the velocity-vector CWS mode (holds track and path angle) the pilot manually entered a holding pattern, shown in figure 38, then recalled the appropriate flight plan page when on the "outbound" track and entered the new arrival time at RMT in the navigation computer. This change "rippled" backward and forward through all flight legs and reset the time box (current scheduled position). Since the EHSI shows only magnetic track it can be seen in figure 38 that the velocity vector CWS mode held track very well against the existing 90 kt direct crosswind from the west. It is obvious that during the turns considerable drift occurred, necessitating an intercept angle inbound. Although this was the first such maneuver for the pilot, he was able to make use of the predictive trend vector ahead of his aircraft symbol (the forward ends of the dashes represent 30, 60 and 90 seconds ahead), and the rescheduled time box with the 30, 60, and 90 second time dots ahead of it, to judge the start of his in-bound turn and the maneuver to re-acquire the time box. Other aids to the pilot for time control are a dashed and displaced flight path acceleration command bar (see label Flight Path Acceleration on figure 11) for use of throttles, and a readout of time error and time error per minute, separation or closure, on the NCDU display shown in figure 10. Figure 38 shows that the pilot was able to close on the inbound track only 5 seconds behind the time box. He continued closing until he again coupled with the automatic mode 1.5 seconds behind the time box. The aircraft arrival at touchdown (rescheduled) was within 5 seconds of that planned.

Consideration is being given to revising the predictive vector dashes to represent one and two minute intervals, which may be more convenient for use in performing standard rate turns (2 minutes per 180 degrees). Indeed, the predictive information could well have several alternative representations and scalings, such as distance or time for a metering and spacing environment.

An important conclusion is that the displays and CWS modes give the pilot an alternative method of accurate navigation and control, which permits him quick reaction time for an occasion such as the change in arrival time requested, or avoiding a threat. The track angle hold mode gave him time on the outbound leg to reprogram the computer to the readjusted time for further automatic flight. Without the displays he would not have been able to execute this type of re-positioning pattern with any degree of expediency or precision on his own. It is felt that this control/ display capability is very necessary for the wide spread success of RNAV/4-D navigation in the future environment.

#### OTHER RESEARCH ACTIVITIES

Additional research activities, presently being focused or planned as future efforts, are required to accomplish the TCV objectives and to address the many operational aspects of the terminal area operation as previously outlined in figure 6. These areas of research are: metering and spacing, local flow management/profile descent, curved path guidance for both automatic and manual flight, wind shear hazard alleviation, landing displays, landing and turnoff operations and cockpit display of traffic information. The extent of research accomplished or planned in each of these areas varies from feasibility studies or benefit analyses, to simulations, and to flight tests for verification and demonstration. Each of these areas of research are discussed below.

**METERING AND SPACING** - Metering and spacing (M & S) is an initial time-based control concept for controlling aircraft from the metering fix to the runway. A fixed path speed control concept (of M & S) currently under study is one in which the ATC aids an aircraft to achieve a scheduled landing time by issuing air speed commands to the pilot at preselected locations in the airspace.

A joint NASA/FAA study has been implemented to evaluate application of the microwave landing system (MLS) to an automated terminal area metering and spacing concept. Present efforts include considering more fully the interactions between multiple aircraft in the terminal area. In addition, it is necessary to determine if theoretical results will be confirmed with human pilots in the control loop. Also, it is necessary to determine if the maneuvers for path stretching and speed control are acceptable to the pilots.

Figure 39 illustrates the control procedures necessary for the metering and spacing concept being evaluated and is discussed further in (ref. 11). A tentative schedule and estimated time of arrival (ETA) is computed upon entry of the aircraft into the terminal area and the schedule is adjusted as indicated on the figure during the approach maneuver. The final schedule adjustment is done using a direct-course-error (DICE) readout technique. This technique determines the error at the runway which occurs if an aircraft turns immediately to predetermined points on the path. For this research it is assumed that all aircraft have the capability for utilizing the MLS and 2-D area navigation.

The terminal area traffic simulation has been integrated with the TCV cockpit simulator. The simulations are being conducted to determine statistics on delivery error to the runway threshold and other specified points along the approach path.

LOCAL FLOW MANAGEMENT AND PROFILE DESCENT - Local flow management (LFM) is a term used to describe a system of matching the demand on an airport to that airport's capacity by using time control at the metering fixes. A separate but closely related technique used with the LFM is profile descent (PD), an uninterrupted descent from cruising altitude/level to interception of a glide slope or minimum altitude specified for the initial approach segment. Figure 40 illustrates a typical LFM/PD. FAA circulars A.C. No. 90-71 and 90-73 describe the procedures for the PD and LFM, respectively. The LFM is a time base metering scheme to systematically control traffic prior to delivery to the Approach Control and the profile descent allows a clean descent at or near flight idle from en route cruise altitude to the final approach. Initially, these two techniques are being introduced at the Dallas-Fort Worth and Denver airports.

It is planned to evaluate the utility of the TCV Program EHSI displays for execution of profile descents. The TCV aircraft system is capable of predicting speed or time at a way point ahead based on the instantaneous conditions while simultaneously making good a desired profile. The task to be performed is to follow the profile in a precise manner to meet the ATC constraints on speed, altitude and time, and still achieve a fuel efficient descent. Utilizing the EHSI display with range and speed or time symbology, assuming sufficient control and typical wind conditions, the predefined profile for the terminal area will be flown in simulation and in flight test.

Measurements shall be taken to provide information on the following areas of research interest: performance with respect to time and speed, fuel efficiency, pilot and controller workload, and communication loading.



GENERALIZED CURVED PATH GUIDANCE AND CONTROL FOR AUTOMATIC FLIGHT - Earlier in this paper it has been pointed out that, to date, automatic flight with the TCV B-737 within MLS coverage has used, as an expedient, an ILS capture technique. During curved path portions of the approach the RNAV system uses MLS signals through its normal control laws to deliver the aircraft to the final straight-in portion of the approach. Delivery must be within narrow limits of displacement and cross-track velocity with respect to the extended runway centerline and with wings essentially level laterally. When these conditions are satisfied and "land arm" has been selected automatic transfer of control to the more precise autoland mode occurs in which the flight control computers control the aircraft through the landing and roll out. Elements of the displays which are driven by MLS are also affected by this transfer.

This capture technique has resulted in several approaches where strong and changing cross and tailwind components have resulted in captures too late to achieve a reasonably acceptable automatic landing. A more satisfactory technique would be to fly throughout the MLS coverage in the autoland mode without the need for the ILS-type capture. In order to accomplish this the development of digital control laws and algorithms for general curved path guidance throughout the MLS coverage through landing and roll out is under study. These laws will be applicable to both automatic guidance and to display information for monitoring or for manual control.

CURVED PATH GUIDANCE FOR MANUAL FLIGHT - As pointed out in the section describing the manually controlled approaches at NAFEC in 1976, it was not feasible for the pilots to perform the close-in curved approaches to the runway satisfactorily when it was necessary to divide attention between the EHSI and the EADI. The added information on the integrated display greatly aided the task of alining with the runway as long as enough time is available for accurate track adjustment during alinement. Experience indicates that with the integrated display for the paths flown, the minimum length for a straight-in final approach should be 1 to 1.5 n. mi. to provide the needed time for track adjustment.

Some of the limitations of the integrated display for this task may be attributed to the need to shift attention to the track angle pointer to aid alinement, the limited display "look angle" of 20 degrees with which to acquire the computer generated runway symbology in a turn (the angular coverage of the EADI is  $\pm 15$  degrees vertically and  $\pm 20$  degrees horizontally), and the magnification ratio which is only 0.32. A possible improvement in the display might be the addition of sufficient texture or character in the ground plane of the depicted runway to aid in the "sensing" of alinement, which might alleviate the need to shift attention to the track angle pointer so often.

Considering these limitations, it is felt that concepts such as path-way-in-the-sky or tunnel-in-the-sky for large-angle, close-in curved paths should be investigated. These concepts would provide continuous curved path guidance as well as tracking and predictive information throughout the turn. Consequently a pathway-in-the-sky has been designed and explored in a preliminary simulation (ref. 12). Tunnel-in-the-sky and other concepts also will be explored at Langley. In addition, Langley is sponsoring work for development of aiding symbology for runway alignment in combined situation and predictive format (ref. 3).

The work described is aimed toward providing the pilot with adequate information for confident monitoring of the progress of the aircraft toward the ground on the advanced profiles now possible, and for takeover at any stage of the approach for completion or other contingency action.

**WIND SHEAR SENSING AND DISPLAY** - A recent series of aircraft crashes attributable to severe wind shear have focused attention on the shear hazard and have led to the establishment of a large program for research on means to alleviate the hazard. It is felt that no matter how well one estimates shear from a comparison of ground speed and airspeed, or from sensors near ground level, the pilot needs immediate information on shear encounters on his primary displays with which he can instinctively take the proper course and degree of action. It was decided to explore wind shear instrumentation using the EADI in the TCV B-737 since this is the primary approach instrument. The EADI of the TCV B-737, in its normal format, presents instantaneous flight path aiming point, derived from the inertial system, with a pair of separated wedges (see figure 11), which move up and down with respect to the horizon for climb or dive, and left and right from the airplane symbol to indicate lateral drift. They remain parallel to the horizon at all times. To the left of the wedges is a bar representing acceleration along the flight path, or potential flight path angle. When this bar is aligned with the wedges the airplane is in stabilized flight with respect to ground speed.

To adapt the EADI to shear detection the potential flight path angle bar was mechanized to separate from alignment with the flight path wedges in response to airspeed error, related to a selected "bug" speed, and airspeed error rate.

The bar moved above the wedges if speed were high and below if speed were low. The bar thus became a thrust command when misaligned with the wedges. The flight path wedges retained their normal function. The pilot, when encountering shear, would correct changes in the flight path angle, as indicated by the wedges, with elevator input and would correct airspeed changes, indicated by the thrust command bar, with

throttle use in the same sense as for speed control. The pilots found this display very effective in coping with shear of the normal varieties. The display will be investigated for effectiveness in severe thunderstorm shears, definition of which have recently been obtained for implementation in the simulation. These studies will be reported when the evaluation of the display effectiveness with the severe shears is completed. So far, current autopilot systems have not been able to prevent short landings with some of these severe shears.

New automatic control laws for the final approach are being developed to anticipate wind shear and provide lead information for improved control. The wind shear is anticipated from ground speed and airspeed differences along the approach path compared with anticipated ground speed at touchdown derived from known ground winds. Ground speeds in flight can be determined from sources such as an MLS guidance system, ILS co-located DME, Inertial or Doppler navigation system etc. It remains to be seen if such anticipatory automatic systems can cope successfully with the severe storm shears.

In addition to display concepts, a new total energy probe (ref. 13) is being evaluated for application as a wind shear sensor on the TCV B-737. It senses a pressure change of  $-1q$ , a combination of static and dynamic pressures, throughout the required speed range. This measurement is insensitive to sideslip and angle of attack through large ranges, considering only the probe itself. An analysis of how to use this sensor for wind shear detection and display application is underway. The output of the sensor should read a constant value with constant thrust and configuration under constant air mass conditions regardless of flight path angle variations. A change in wind direction and/or velocity, however, will cause a change in flight path angle, correctable by application of longitudinal control, and/or a change in airspeed which will be sensed to derive an appropriate thrust command to compensate for the airspeed change.

LANDING DISPLAYS - Air transportation has become indispensable as a major transportation system in the conduct of national and international affairs. Schedule reliability and safety in the landing approach in low visibility must be improved for future operations. An obvious step toward this capability is required for future systems in order to:

- (1) Improve schedule reliability with regard to weather (ref. 14), not for "airline economics" solely, but for the benefit of industry, military, and the traveling public (national economic welfare).

- (2) Reduce accident potential present in "See-to-Land" concepts in all reduced visibilities, CAT I & II included.
- (3) Reduce landing aborts to the minimum possible because of the impact on an already congested traffic situation.

CAT III conditions (in an "effective" sense) also occur in conditions other than fog with light winds, such as in strong crosswinds with blowing and drifting snow, for example. Thus, CAT III systems must be designed with wider operational envelopes (headwinds, turbulence, shear, crosswinds, tailwinds) than they are today. To add pilot confidence and acceptance to a truly operational CAT III System, it is felt that situation information approaching an "absorb-at-a-glance" format must be available to the pilot. The display must be informative, accurate and compelling enough that the pilot does not feel the need to look elsewhere for flight control information. It must be adequate for the pilot to do something about his situation if it is not to his liking - not simply to execute an abort to cause more problems, unless necessary. In CAT III - like conditions it is considered unlikely that a pilot can concentrate on transient, distorted and inadequate outside references for judgement of the critical landing maneuver and make use of skeletonized HUD information at the same time, except to tell him where to look. Considering these factors it is, therefore, reasoned that head-down-display (HDD) development is necessary in achieving safe and reliable operations in all visibility conditions. Recent European developments tend to substantiate this reasoning (ref. 15).

It is felt that if the display is good enough to give the pilot the information and confidence for monitoring an automatic approach, regardless of outside visibility, it may very well be adequate for manual landing, assuming some form of augmented control system. If this were true, then pilots would be able to retain currency by executing landings with it in normal as well as low visibility operations.

This is not to say that the head-up-display (HUD) should not be used. It is thought that the pilot monitoring the approach should stay on a basic HDD throughout approach and landing. The overall approach and landing manager should, perhaps, have a HUD for whatever information he can obtain with it and outside visual references. Also, the HUD may be a useful backup against failure of the HDD in the eventual system.

It is felt that an operational CAT III "landing" display should be pursued on a long range basis. Today, such a display does not exist in an operational sense. However, Langley is sponsoring research and development of landing display technology. Computer-generated images of terrain and airport features and runway texture and markings are being

evaluated with respect to contributions to approach and, particularly, landing performance. A modest range of color, shading and a spread of magnification ratio are being investigated, all in a head-up position as though looking through the windshield in this case. An oculometer is being used also to obtain look points for different pilots with the differing display formats. The data are being analyzed to see if an understanding can be obtained of what information the pilot is seeking and using. The pilots being evaluated include research, airline, instructor and executive types. No conclusions have been drawn as yet as the program is ongoing.

**LANDING AND TURNOFF OPERATIONS** - Increased efficiency and capacity of operations in the terminal area are considered important TCV research objectives. As en route, descent, and approach operations improve, the landing and runway occupancy time will become the major constraint in achieving overall capacity increases.

As illustrated in figure 41, (ref. 16), the potential increase in capacity resulting from a reduction in spacing is significant. In the study of (ref. 16) a traffic mix of only two types of aircraft was used, a large aircraft with a final approach speed of 127 knots, and a heavy aircraft with a final approach speed of 137 knots. When compared to current vortex separation standards the gain in capacity with a 3 n. mi. separation goes up appreciably with the increase in percentage of heavy aircraft (due to speed) as shown in the figure. This is a significant factor as more heavy aircraft go into service. Also noteworthy is the significant capacity gain due to increased delivery accuracy at the runway in terms of time. There is thus an urgent requirement for better performance of the future traffic control systems in terms of time. The curves for 2 n. mi. separation illustrate what may be achieved with further alleviation of the vortex hazard and a reduction of runway occupancy times.

Efficient operation resulting in high capacity cannot be achieved unless aircrafts can land and consistently exit the runway in minimum time. This must be accomplished even in very low visibility conditions.

To achieve this objective, better aircraft control is required to consistently land at a more precise point on the runway. After touchdown, the aircraft must quickly exit, so as to allow for the safe approach and landing of trailing aircraft. Runway exits which will allow much higher exit speeds must be designed for optimum operations, considering also safety, tire wear, and passenger comfort.

The TCV Program is performing research in a number of areas in an attempt to solve these problems. New autoland control laws which include the flare and improved autothrottle action, with and without direct lift control, are being developed to cope with shear and the effects of ground winds in improving the precision of touchdown.

Coupled with this activity is the necessity for pilot display development to allow monitoring or control of landing roll out deceleration and turnoff.

An angled exit concept is being studied which will provide information on exit speeds, turnoff design, distance and time from touchdown to exit, and other parameters. Control laws have been developed for automatic high speed turnoff considering a magnetic leader cable for guidance. Such a system is ready for ground test. A runway turnoff is to be built at the NASA Wallops Flight Center for flight evaluation of pertinent parameters and control and display concepts.

**COCKPIT DISPLAY OF TRAFFIC INFORMATION (CDTI)** - The concept of providing traffic information to the aircrew through the use of advanced displays is one that has been explored for a number of years. Research in this area has been conducted by several groups and there still remains an issue as to the role and application of the CDTI in the future ATC process.

Potential benefits of the CDTI fall into the general areas of improved capacity, efficiency, and safety. Proponents of the CDTI believe its application in the ATC process can improve terminal area capacity by allowing for reduced aircraft separation, efficient merging, and general improvement in aircraft traffic control and crew execution. Simulation studies addressing these issues are reported in (ref. 17).

In addition, a display of the traffic situation can provide to the aircrew a better awareness of the traffic environment in order to operate with an acceptable level of confidence and of safety. By providing sufficient information, collisions may be avoided by providing advanced indications of traffic conflicts wherein the controller and aircrew can make course changes to resolve the conflict. The display may also serve as a backup for certain ATC system failures.

Concerns for the use of the CDTI are that it may result in less efficient operations, with the aircrew challenging the air controller, increasing workload and possibly unilateral action resulting in less control and safety. The effect of CDTI usage on the air traffic controller and aircrew operational procedures and workload must be determined to judge its utility in the ATC system.

One of the major issues is the role of the CDTI in the overall ATC process. Should its use be passive as in a monitor role, where its application is to provide the aircrew with independent information on traffic for providing assurance and an error detection capability? Or, alternatively, can the CDTI be applied in an active role, utilizing the traffic display to control in-trail spacing and lateral separation and to resolve traffic conflicts, etc? Ultimately, if the CDTI is a useful approach for improving the ATC operations, its application may be a compromise between the two roles described above. The aircrew will be able to utilize the CDTI to execute certain functions that are best controlled from the air, with knowledge of the controller, who has the overall ATC responsibility.

In an attempt to answer the above and related questions, the NASA Langley Research Center is participating in a joint program with the FAA and NASA Ames to evaluate the capabilities, benefits, and liabilities of the CDTI in the future ATC environment. Items to address are the means for providing data of sufficient accuracy and frequency, the role of aircrew and controllers in the ATC process, evaluation of performance and accuracies to determine effects on capacity, controller and aircrew workload, and effects on safety.

Excellent previous work has been done in this area, as reflected in a number of reports (ref. 17 and 18). The approach being taken in this joint effort is to use the previous research effort as a base and to pursue a rigorous program to explore the concept of CDTI in various roles in the future ATC system, culminating in a series of flight tests to verify the results.

The NASA Langley Research Center with its unique simulation and advanced aircraft (TCV B-737) capability. will particularly address the operational aspects of the CDTI in the terminal area. CDTI will be evaluated in a total system concept, considering CTOL aircraft of varying capability, using the advanced systems described earlier in this paper. Both simulation and flight programs on the addition of traffic to the present Electronic Horizontal Situation (EHSI) map display are being pursued, with the full range of display and control capability available on the TCV aircraft.

One possible application of the traffic to the EHSI map is illustrated in figure 42. Ownship aircraft (B-737) is shown in the middle of the screen with pertinent traffic in the approach shown within 10 n. mi. of ownship. This figure includes waypoints, terrain symbology, flight plan, aircraft identification, speed, altitude and other symbols. Several options, including predictive vectors for all aircraft, are

being pursued to enhance display symbology and format to define an effective display. In this scenario ownship is landing after a DC-9 and is being followed in order by a B-727 and a B-727S. The position of ownship relative to the time box indicates that ownship is proceeding on schedule.

NASA and FAA are developing test scenarios to address the various roles and application of CDTI in projected ATC environments to the year 2000. Flight tests with the TCV aircraft are planned at the NASA Wallops Flight Center (WFC) and FAA National Aviation Facilities Experimental Center (NAFEC).

#### CONCLUDING REMARKS

1. Accurate 4-D flights over long distance for control of arrival times are readily feasible. Accurate control of threshold arrival times can result in large increases in capacity, particularly if longitudinal spacing of aircraft can be reduced.
2. Instrumentation for 4-D fuel efficient descents is feasible, simulations have been performed, and it is planned to explore its use in a terminal area environment soon, working with FAA air traffic personnel.
3. The TRSB MLS provides very precise guidance that an automatic system can follow accurately for close-in curved paths, approaching VMC operational capability, through landing and roll out. Through use of advanced electronic displays the pilot, using CWS modes, can also fly equivalent curved paths manually with overshoots of 50 m or less, generally, during alignment with the runway as close as one mile, even with very little practice. The paths can save time and airspace on arrival, as well as provide merge capability from several directions. Because of the reduced possibility of significant overshoot, more closely spaced runways for simultaneous approaches in IMC seem feasible.
4. Alleviation of noise impact on the ground through use of avoidance paths is feasible and has been well demonstrated.
5. In order to take advantage of improved displays the controls and displays must be considered together in design as a single system to assure quick and precise corrections and maneuvers.



6. CRT displays in combination with appropriate sensors for providing advanced information enable the crew to navigate and control the aircraft manually with precision and safety in 4-D flight in lieu of automatic control or in any combination of automatic and manual control. The displays also provide redundancy for the automatic modes, permit piloted contingency action, and permit instant response to ATC directives without reprogramming the flight computers.
7. Display of pertinent traffic on the navigation displays, particularly in the terminal area, would seem to be very important for crew assurance, at least, in closely spaced traffic, even in visual conditions. With additional display enhancement it may prove feasible for the crew to establish and maintain its own separation, or to take threat avoidance action when required. Early flight experiments with these concepts are planned.
8. Distributed control is a viable concept for the future, particularly with advanced displays for the pilot, and has been illustrated during TRSB MLS demonstrations in Buenos Aires, New York and Montreal.
9. In retrospect, pilots found curved approach paths to runways both acceptable and comfortable (as for VFR), and passengers offered no adverse comments (700 passengers) as long as the maneuver to correct the transition error from RNAV to MLS guidance is moderate.
10. It cannot be over emphasized that the TCV Program, as well as some other NASA programs, must work hand-in-hand with FAA to accelerate the application, exploitation and integration of promising research results into the air traffic system toward needed major improvements. This applies to research on-going in navigation, guidance, communications and airborne systems, as well as operating techniques and procedures.

#### REFERENCES

1. AATMS Program Office, "Advanced Air Traffic Management System Study - Technical Summary." Final Report, DOT-TSC-OST-75-6, March 1975.
2. H. W. Withington, "Commercial Air Transportation Developments in the Next Three Decades." Conventional Takeoff and Landing Conference, NASA Langley Research Center, February 28-March 3, 1978.

3. S. Salmirs and S. A. Morello, "Flight Experiments to Improve Terminal Area Operations." Conventional Takeoff and Landing Conference, NASA Langley Research Center, February 28-March 3, 1978.
4. J. P. Reeder, R. T. Taylor, and T. M. Walsh, "New Design and Operating Techniques for Improved Terminal Area Compatibility." Air Transportation Meeting, Dallas, Texas, SAE Paper No. 7404, April 30-May 2, 1974.
5. T. M. Walsh, S. A. Morello, and J. P. Reeder, "Review of Operational Aspects of Initial Experiments Utilizing the U.S. MLS." Aircraft Safety and Operating Problems Conference, October 18-20, 1976.
6. T. M. Walsh and E. F. Weener, "Automatic Flight Performance of a Transport Airplane on Complex Microwave Landing System Paths." AGARD 25th GCP Symposium, Dayton, Ohio, October 17-20, 1977.
7. G. G. Steinmetz, S. A. Morello, C. E. Knox, and L. H. Person, Jr., "A Piloted-Simulation Evaluation of Two Electronic Display Formats for Approach and Landing." NASA Technical Note, TN D-8183, April 1976.
8. S. A. Morello, "Recent Flight Test Results Using an Electronic Display Format on the NASA B-737." AGARD 25th GCP Symposium, Dayton, Ohio, October 17-20, 1977.
9. C. E. Knox, "Experimental Determination of the Navigation Error of the 4-D Navigation, Guidance, and Control Systems on the NASA B-737 Airplane." AGARD 25th GCP Symposium, Dayton, Ohio, October 17-20, 1977.
10. S. A. Morello and L. H. Person, Jr., "Terminal Area Flight Experience with the NASA Terminal Configured vehicle." Flight Safety Foundation 23rd Corporate Avionics Safety Seminar, Arlington, VA April 10-12, 1978.
11. C. L. Britt, Jr. and L. Credeur, "Research in Ground-Based Near-Terminal Area 4-D Guidance and Control." Paper presented at the Tenth ICAS Congress, No. 76-59, October 3-8, 1976.
12. C. E. Knox, J. Leavitt, "Description of Path-in-the-Sky Contact Analog Piloting Display." NASA Technical Memorandum 74057, October 1977.
13. O. W. Nicks, "A Single Total Energy Sensor." NASA TMX 73928, March 1976.

14. C. A. Collin, H. Unvoas, "Category III Landing Minima." International Conference on the Future of Aircraft All Weather Operations, London, England, November 23-26, 1976.
15. K. J. Stein, "Export Efforts Seek Turnkey Programs." Aviation Week and Space Technology, pages 281-296, June, 6, 1977.
16. L. Credeur, "Basic Analysis of Terminal Operation Benefits Resulting from Reduced Vortex Separation Minima." NASA Technical Memorandum 78624, October 1977.
17. M. E. Connelly, "Simulation Studies of Airborne Traffic Situation Display Applications -- Final Report." Massachusetts Institute of Technology Report ESL-R-751, May 1977.
18. Boeing Commercial Airplane Company, "Cockpit Displayed Traffic Information Study", Report No. FAA-EM-7718, September 1977.

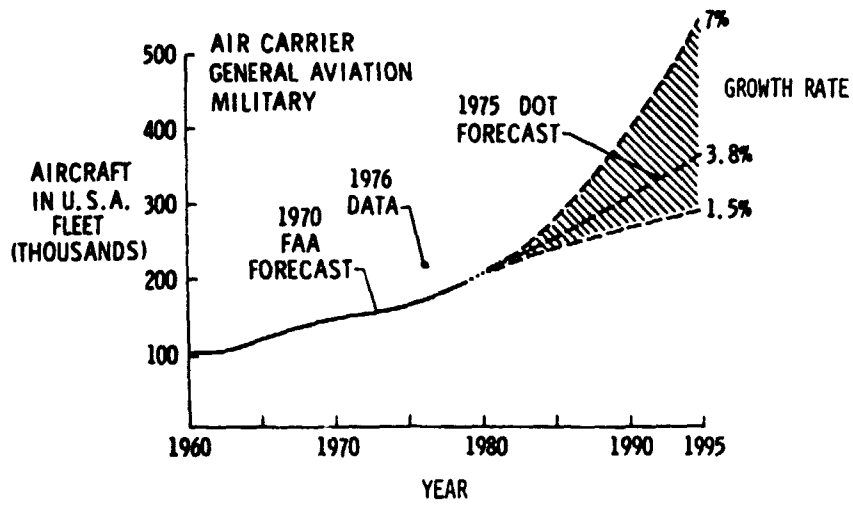

Figure 1. - U.S. Air Fleet Growth Projections

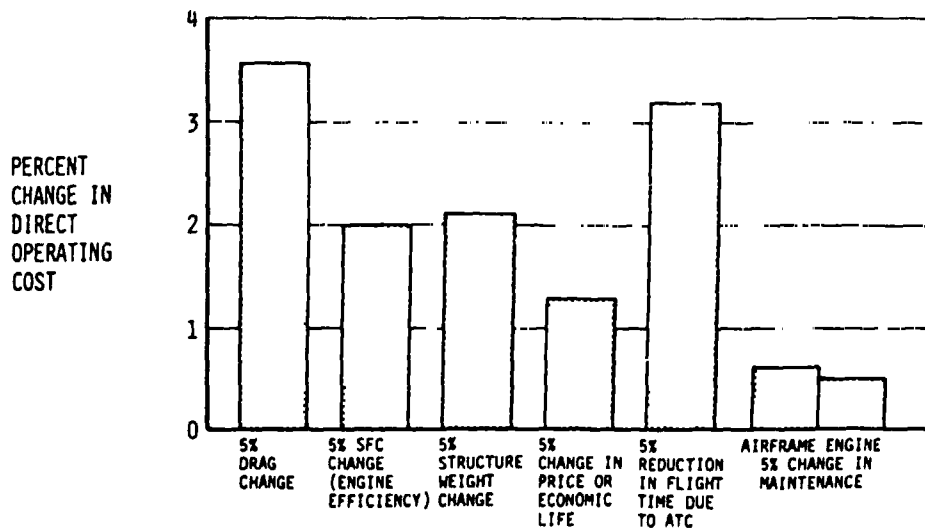

Figure 2. - Effect of Airframe and Operating Changes on Direct Operating Cost (DOC)

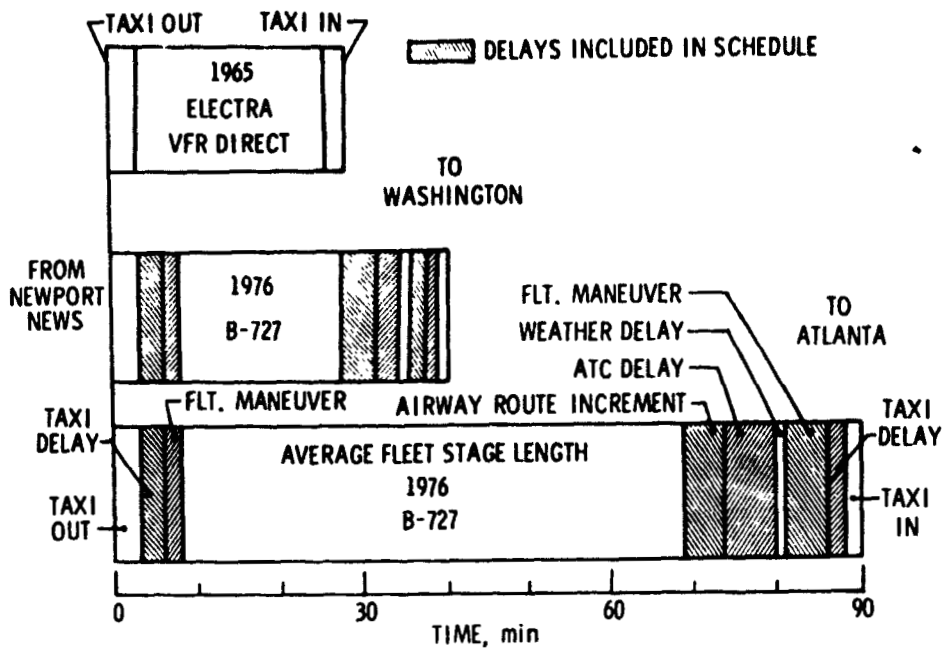

Figure 3. - Airline Schedule Components

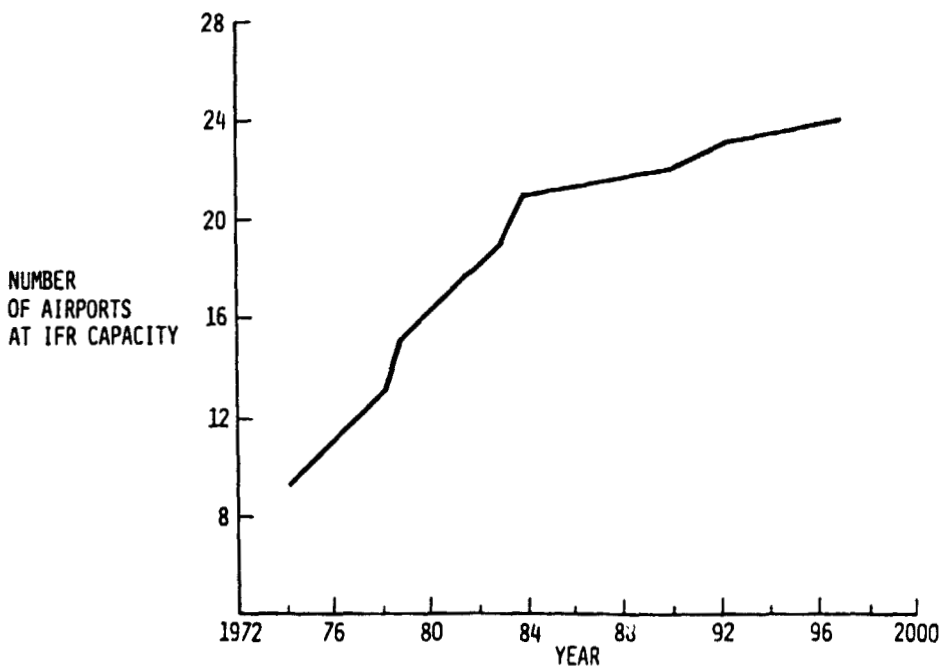

Figure 4. - Airports Reaching IFR Capacity with Present ATC

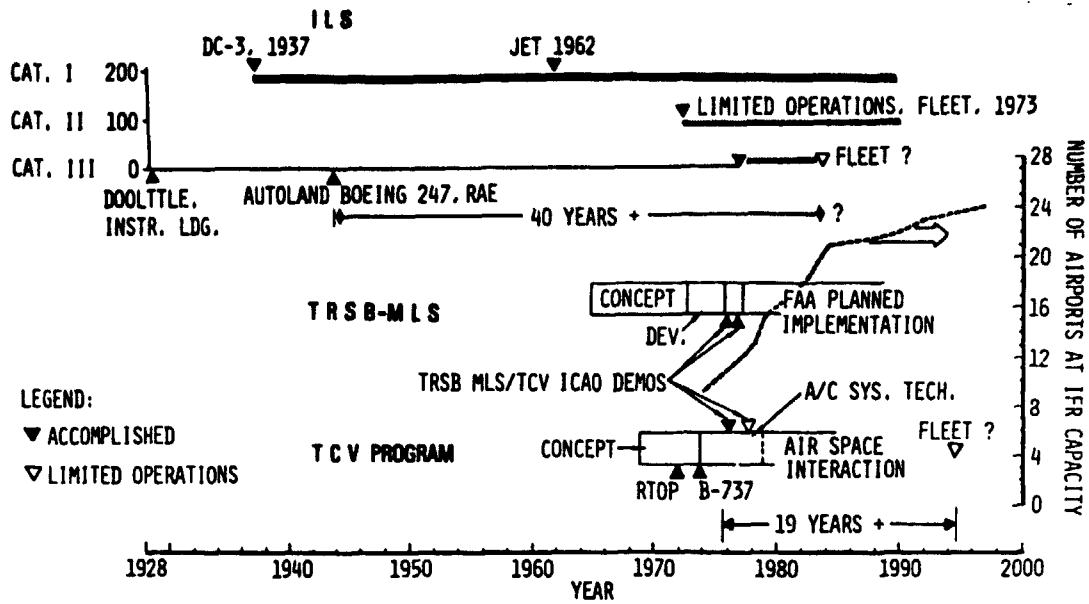

Figure 5. - Summary of Landing System Developments in the U.S.

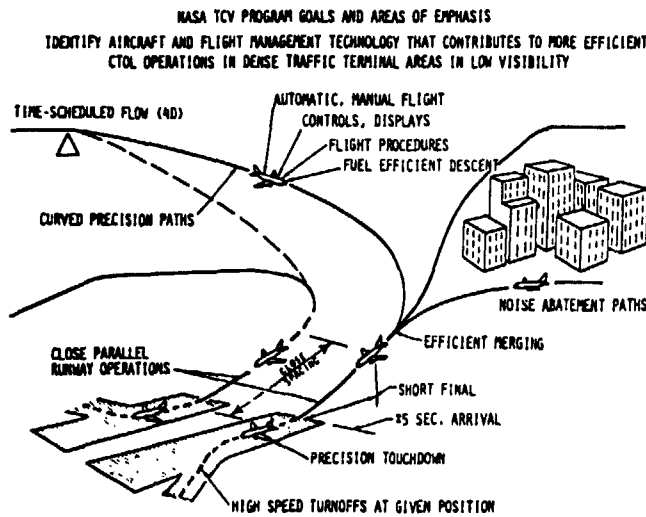

Figure 6. - High Capacity Terminal Area Operations in Low Visibility



Figure 7. - NASA TCV B-737 Research Aircraft

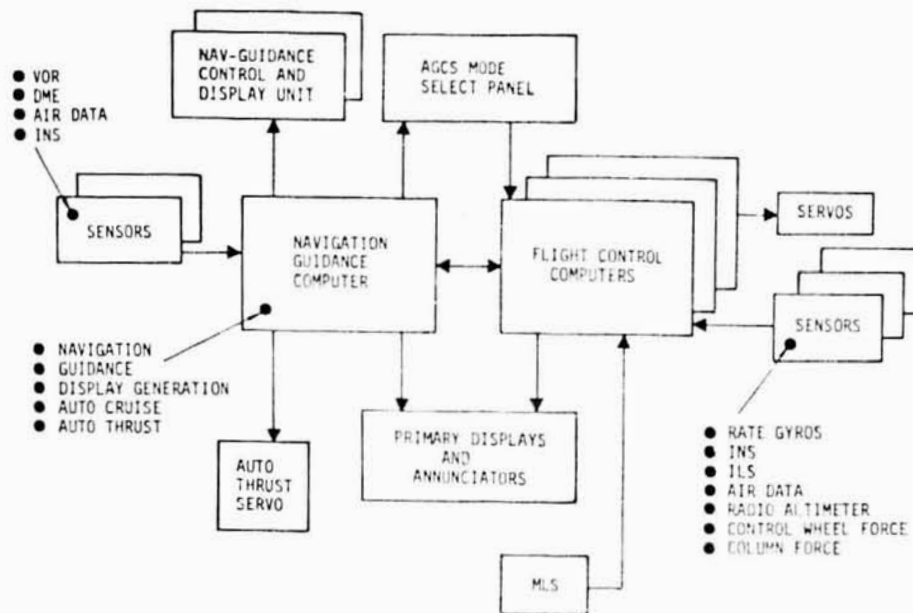

Figure 8. - NASA TCV B-737 Flight Control Configuration

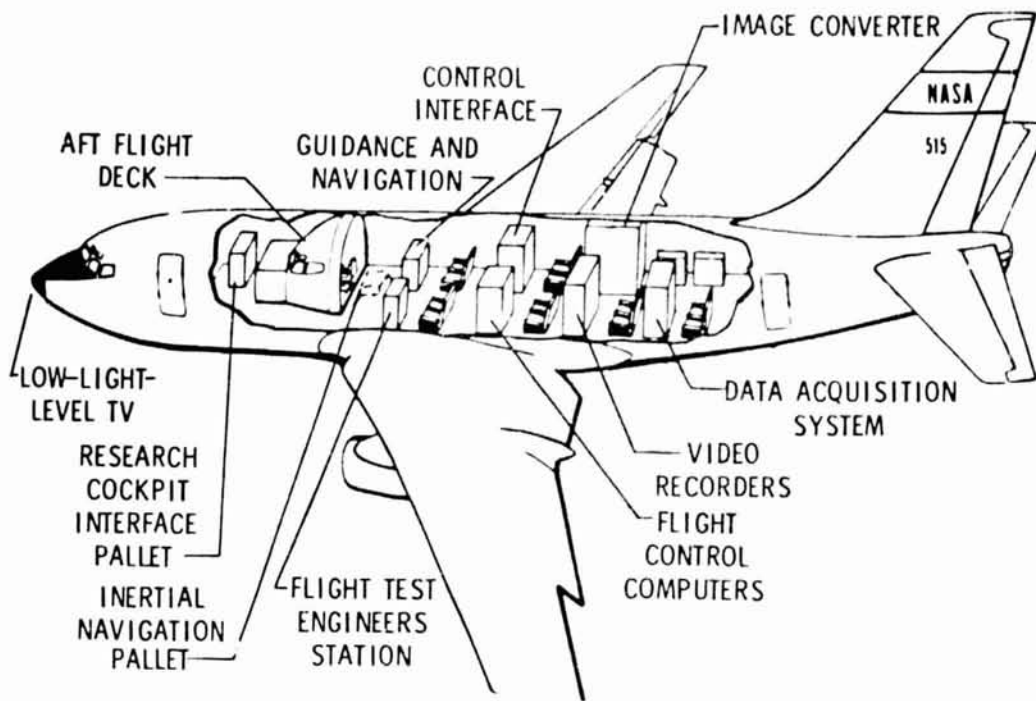

Figure 9. - NASA TCV B-737 Research Aircraft  
(Internal Arrangement)



Figure 10. - Aft Flight Deck Display Arrangement



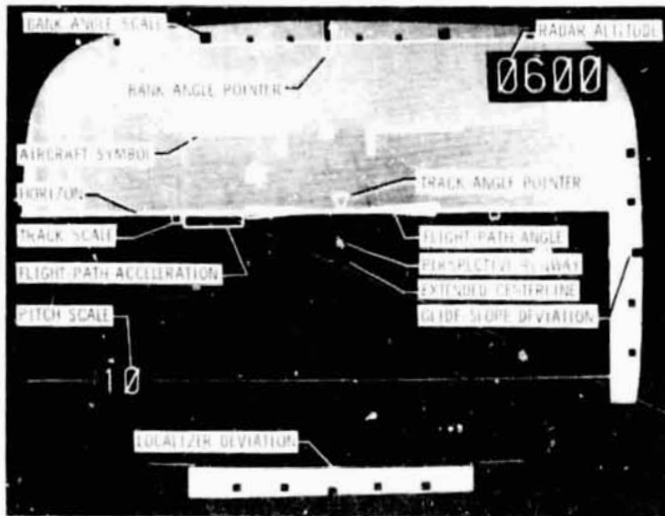

Figure 11. - EADI Display Symbology

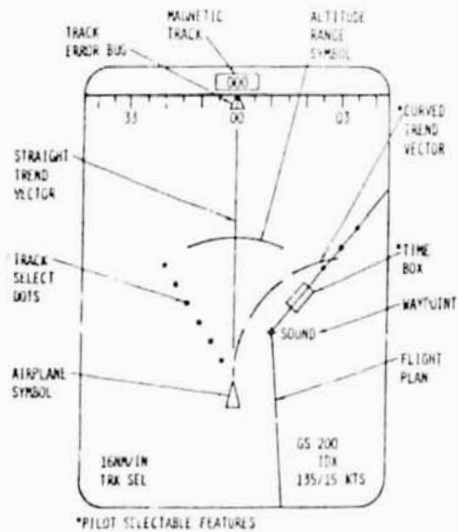

Figure 12. - EHSI Display Symbology

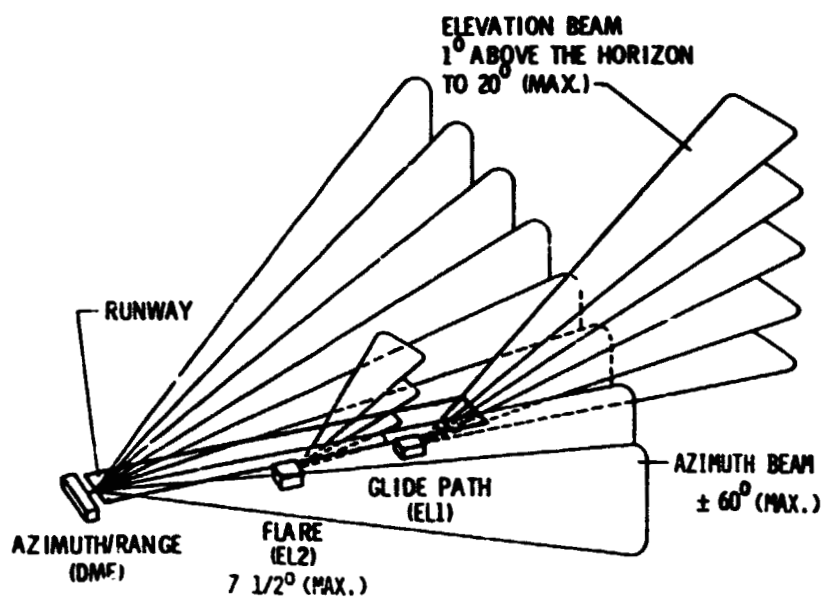

Figure 13. - TRSB Microwave Landing System Scanning Beams

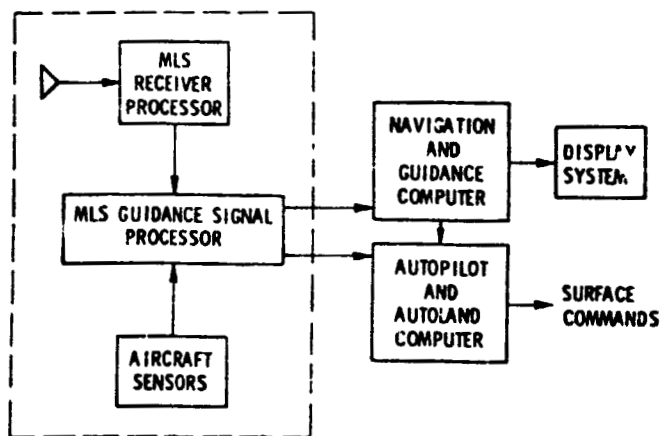

Figure 14. - TRSB Microwave Landing System Integration with NASA B-737 Aircraft

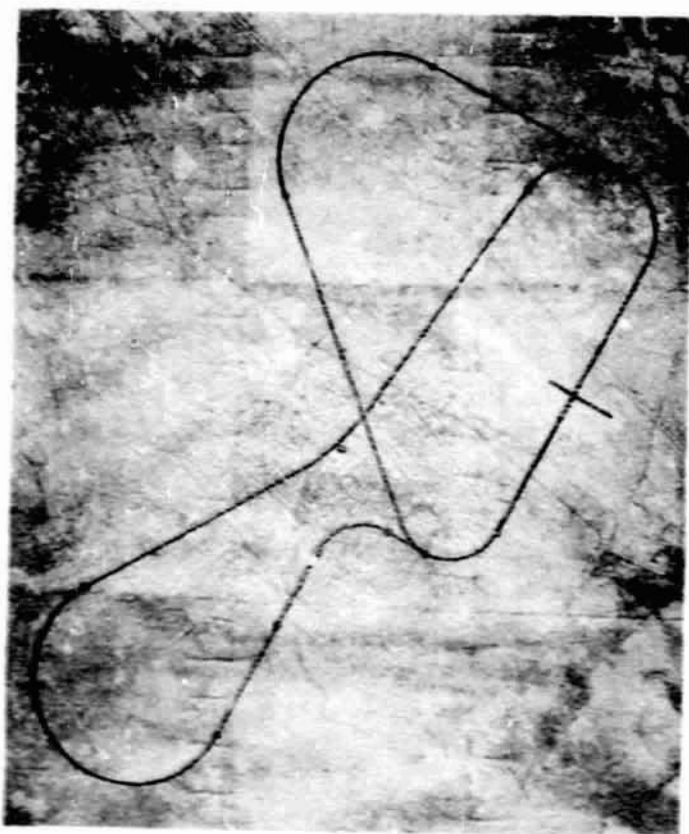

Figure 15. - ICAO Demonstration Paths at NAFEC

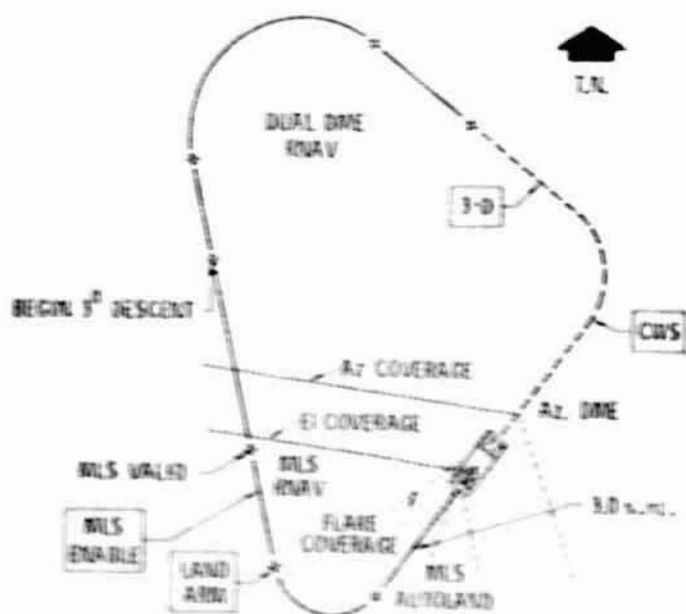

Figure 16. - 130-Degree Turn Azimuth Capture (NAFEC)

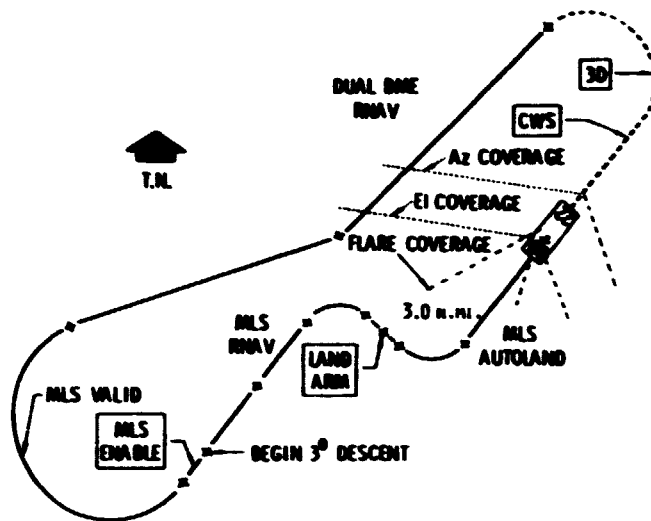

Figure 17. - S-Turn Azimuth Capture (NAFEC)

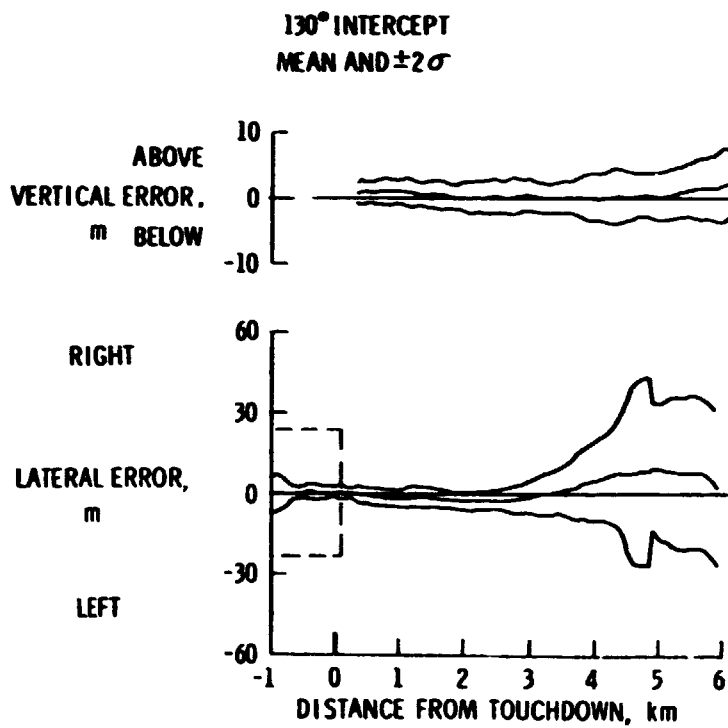

Figure 18. - Summary of Tracking Errors (NAFEC)

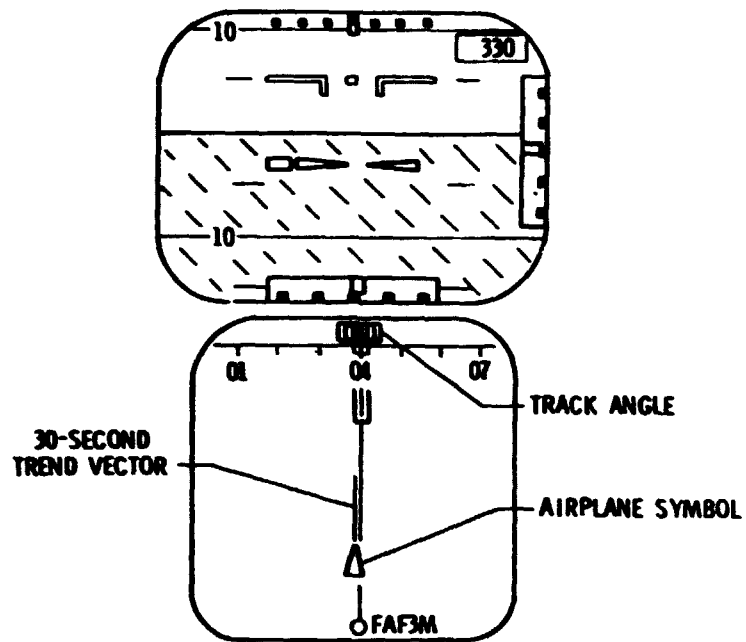

Figure 19. - Baseline Situation Display, EADI and EHSI

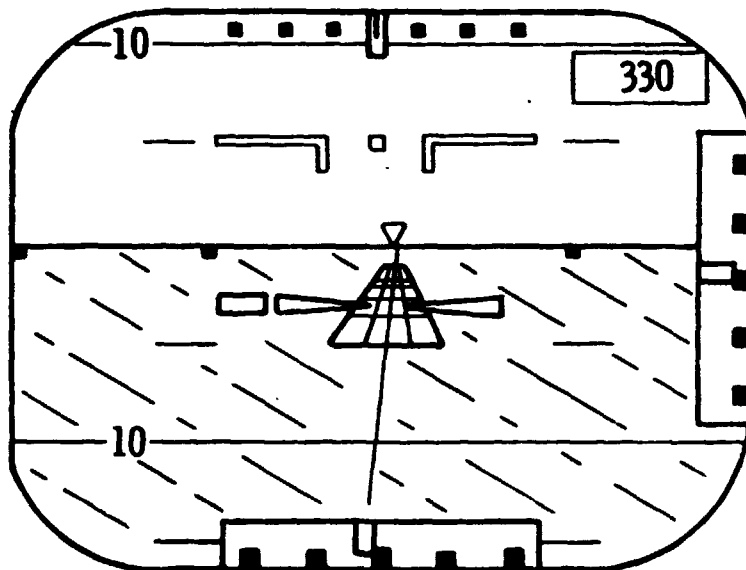

Figure 20. - Integrated Situation Display

ORIGINAL  
OF POOR

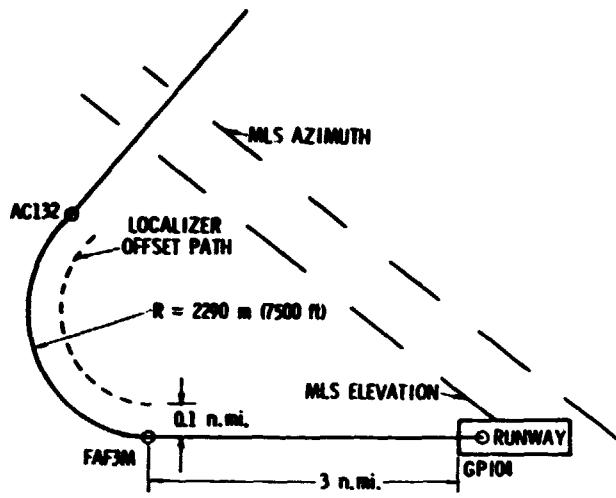

Figure 21. - Approach Pathway to Runway 04 at NAFEC (with offset)

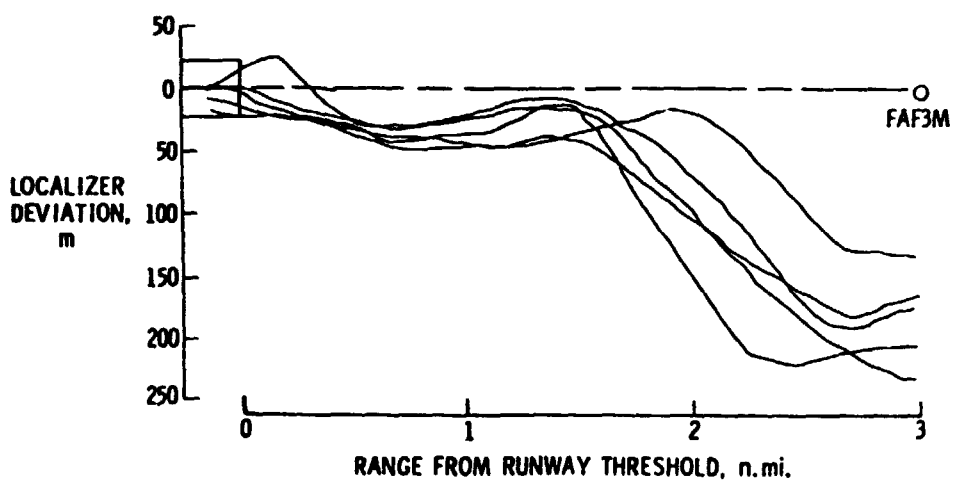

Figure 22. - Runway Alinement Tracking Performance from Offset with Baseline Display

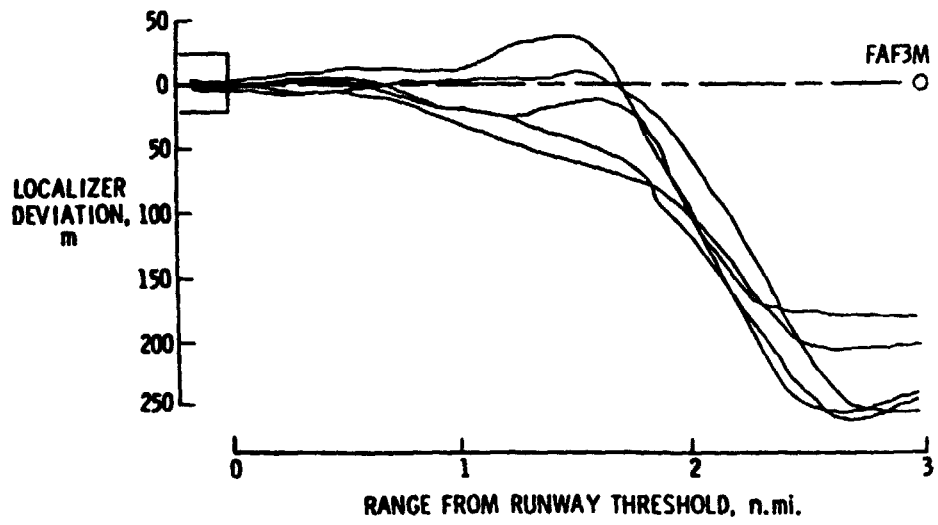

Figure 23. - Runway Alinement Tracking Performance from Offset with Integrated Display

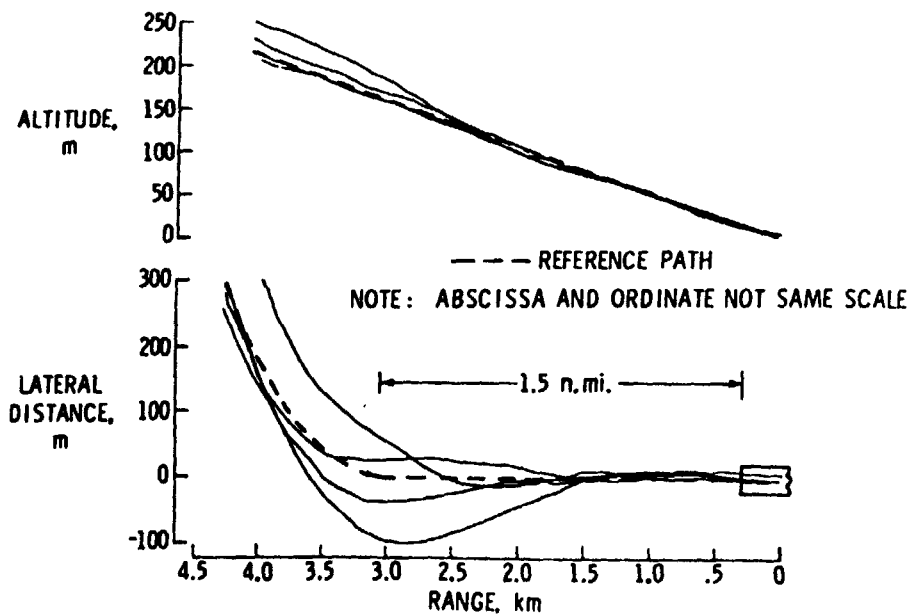

Figure 24. - Runway Alinement from 130-Degree Turn onto 2.78 km (1.5 n.mi.) Final with Integrated Display

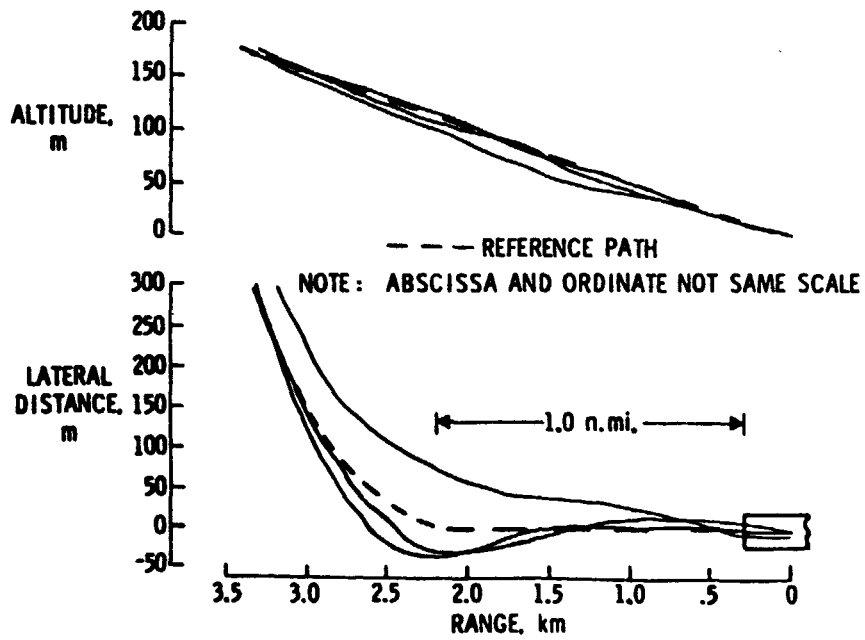

Figure 25. - Runway Alinement from 130-Degree Turn onto 1.85 km (1.0 n.mi.) Final with Integrated Display

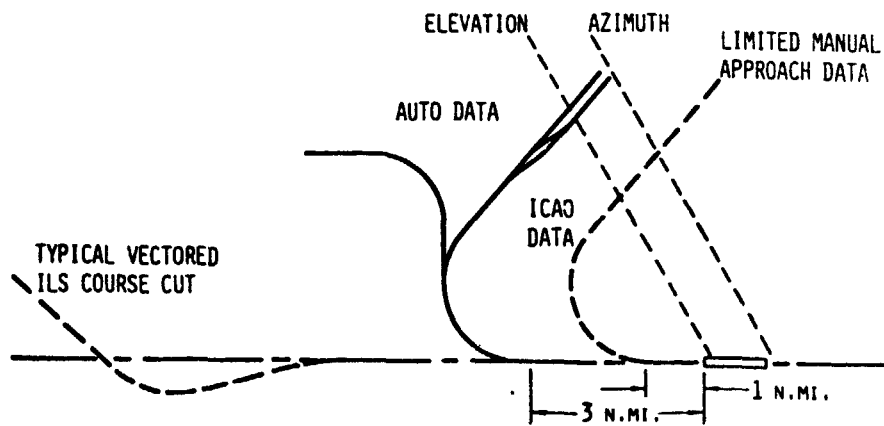

Figure 26. - Summary of Curved Approaches Used at NAFEC, 1976



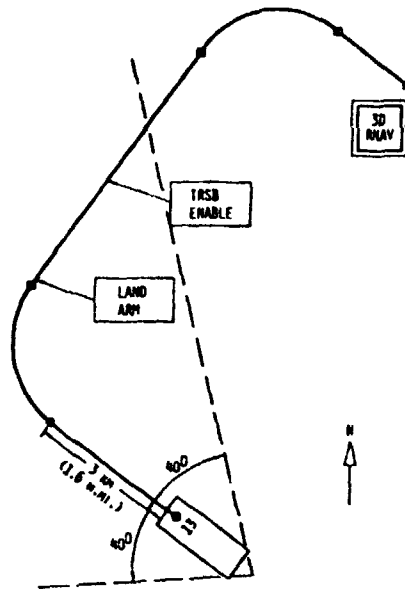

Figure 27. - STAR ABE04, Aeroparque Jorge Newbery

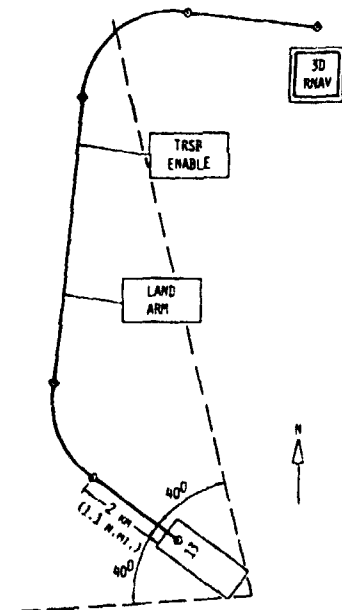

Figure 28. - STAR ABE05, Aeroparque Jorge Newbery

ORIGINAL OF PCCP

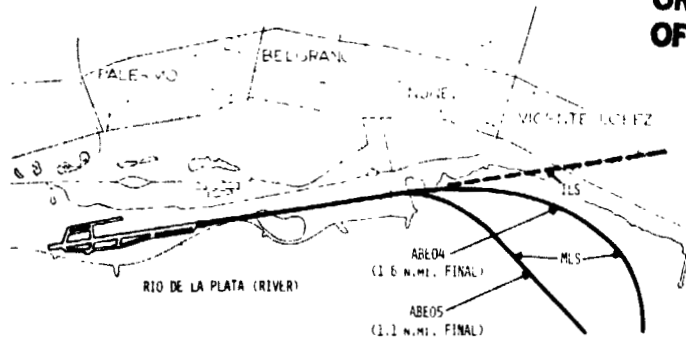

Figure 29. - Approach Paths at Buenos Aires

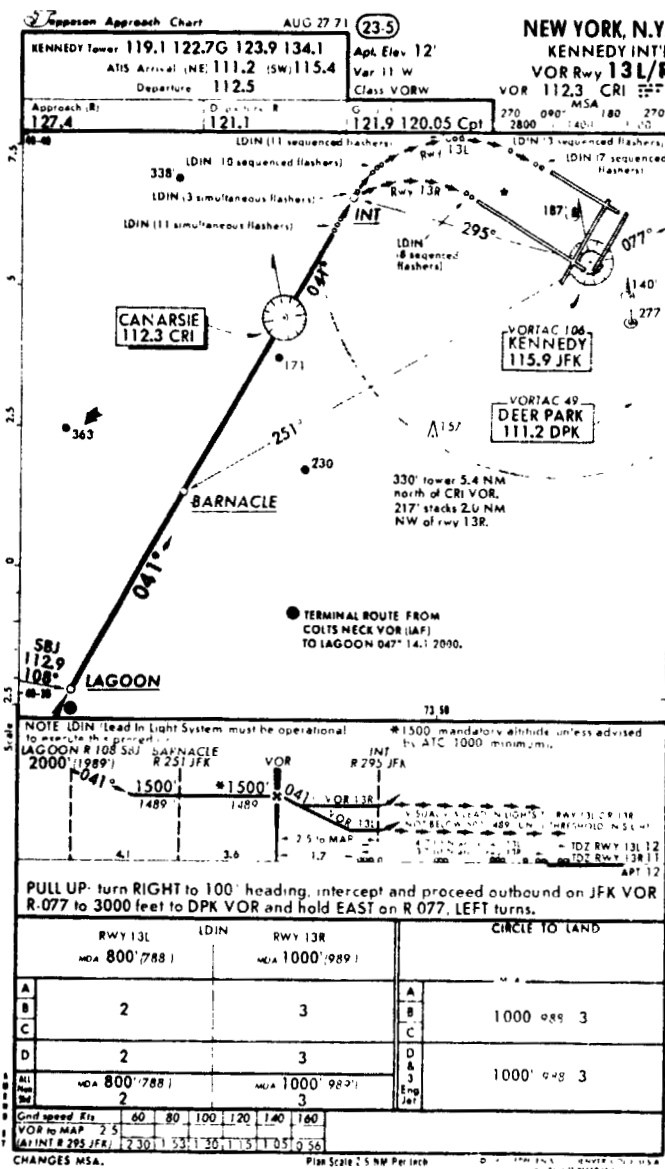

Figure 30. - VOR Runway 13L/13R John F. Kennedy International

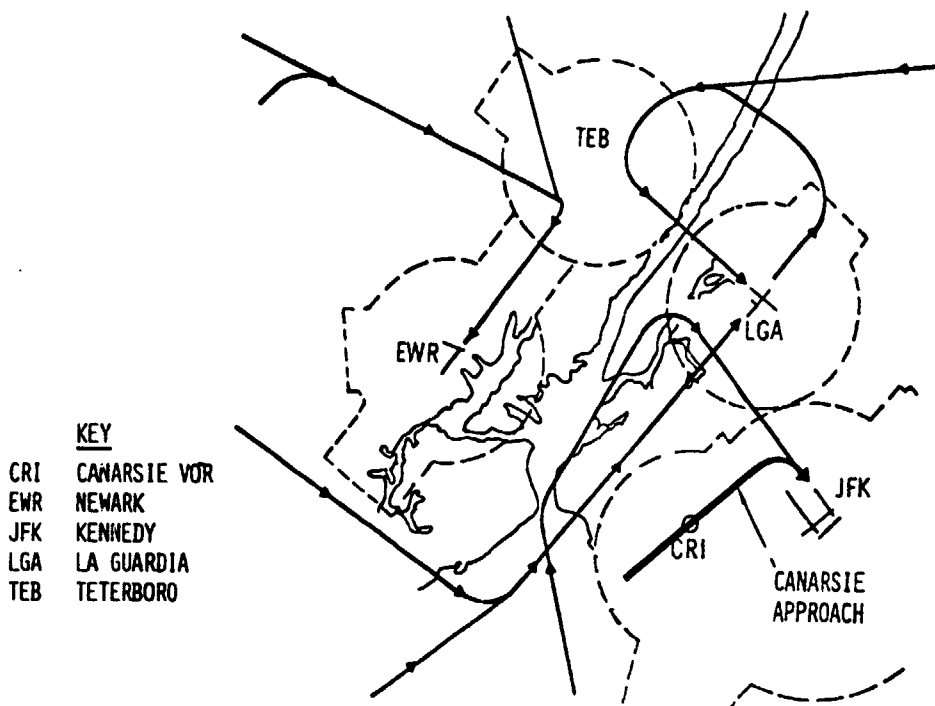

Figure 31. - New York Terminal Area Route Structure

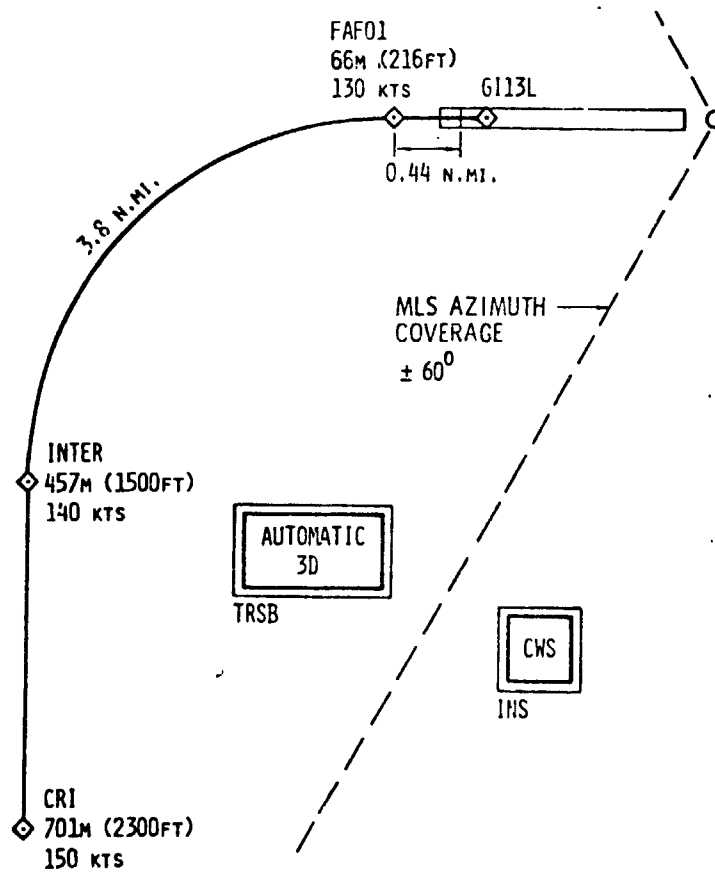

Figure 32. - TRSB Microwave Landing System Approach from Canarsie VOR (CRI)

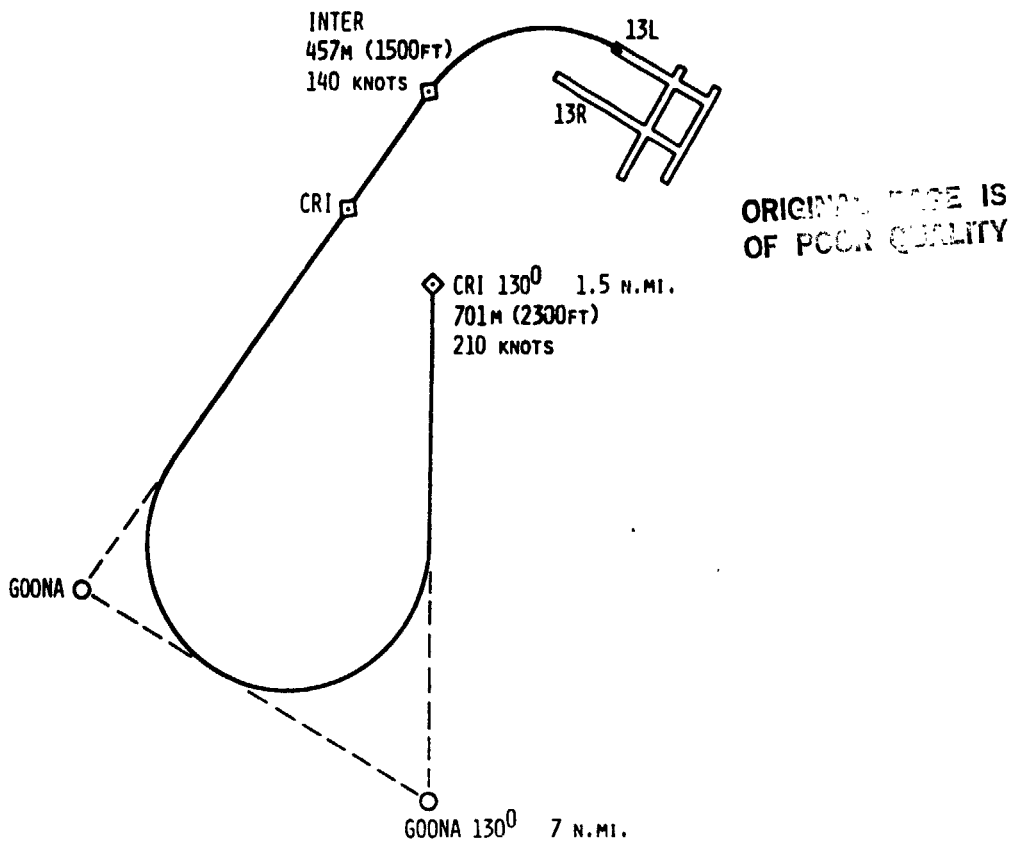

Figure 33. - Entrance Path to Canarsie STAR CAN 01 (JFK)

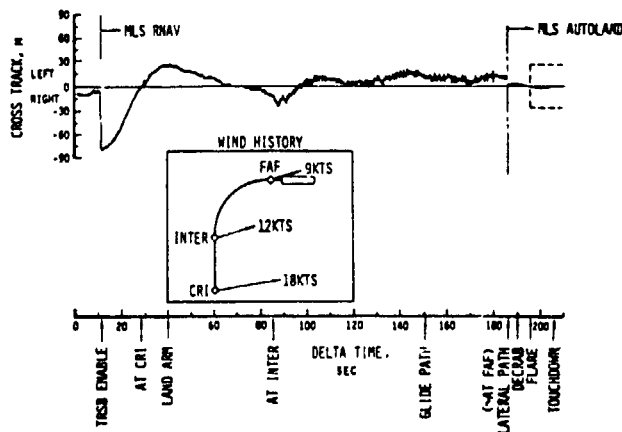

Figure 34. - Lateral Error for Typical Canarsie Approach, Flight 205 Run 8R2

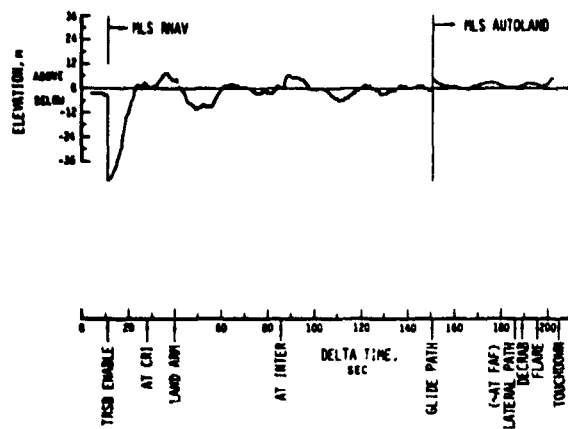

Figure 35. - Vertical Error for Typical Canarsie Approach, Flight 205 Run 8R2

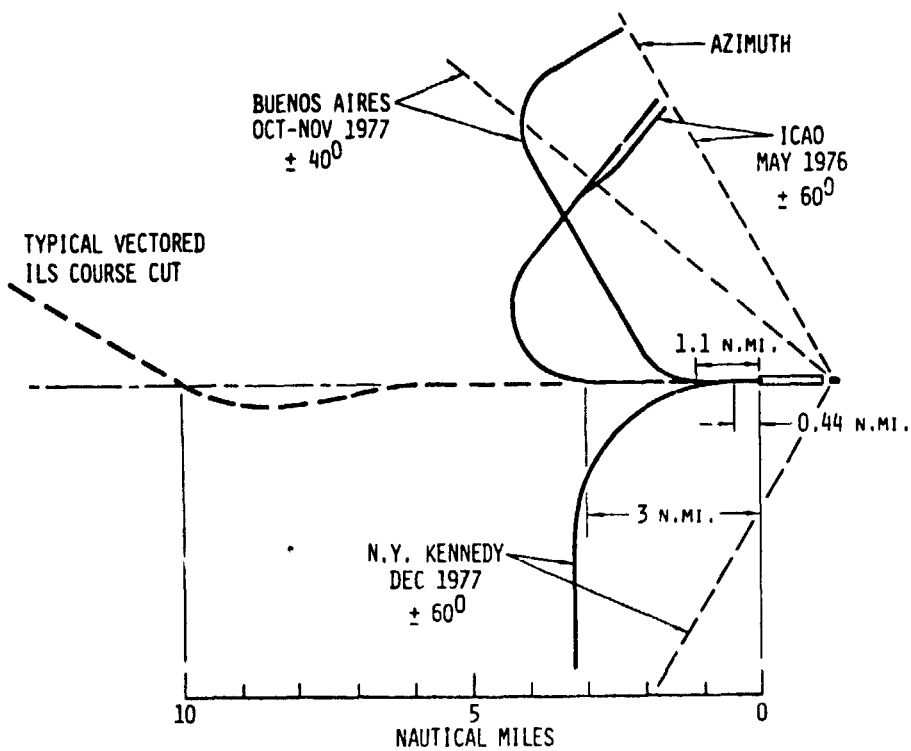

Figure 36. - Summary of Curved Approaches with TRSB MLS

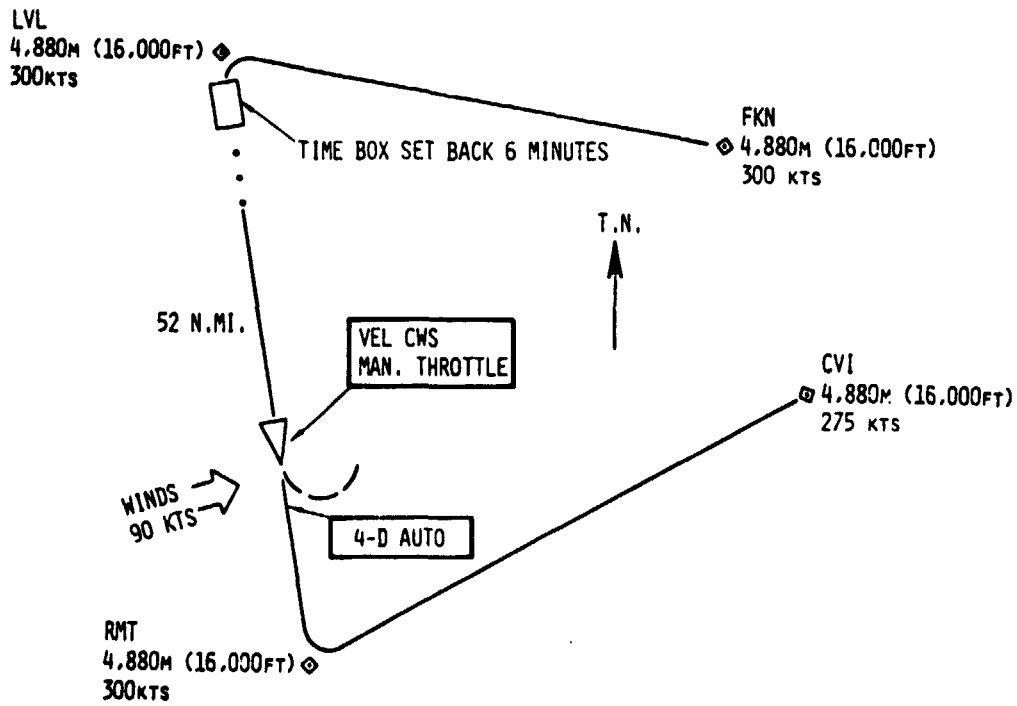

Figure 37. - NASA TCV B-737 4-D Navigation Task

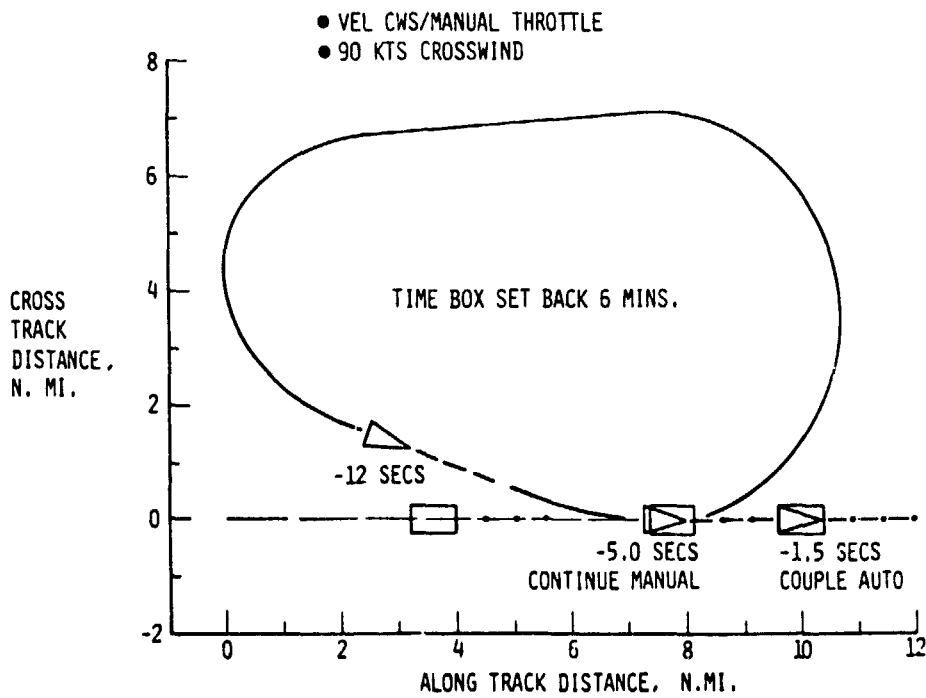

Figure 38. - Hold Pattern, Capture of 4-D Time Box

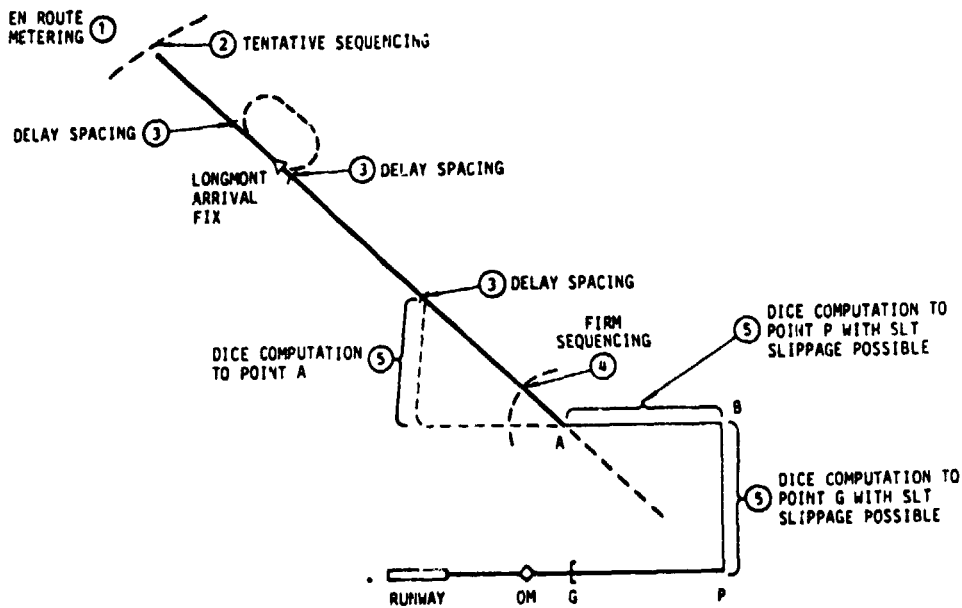

Figure 39. - Current Control Procedures, Metering and Spacing Concept

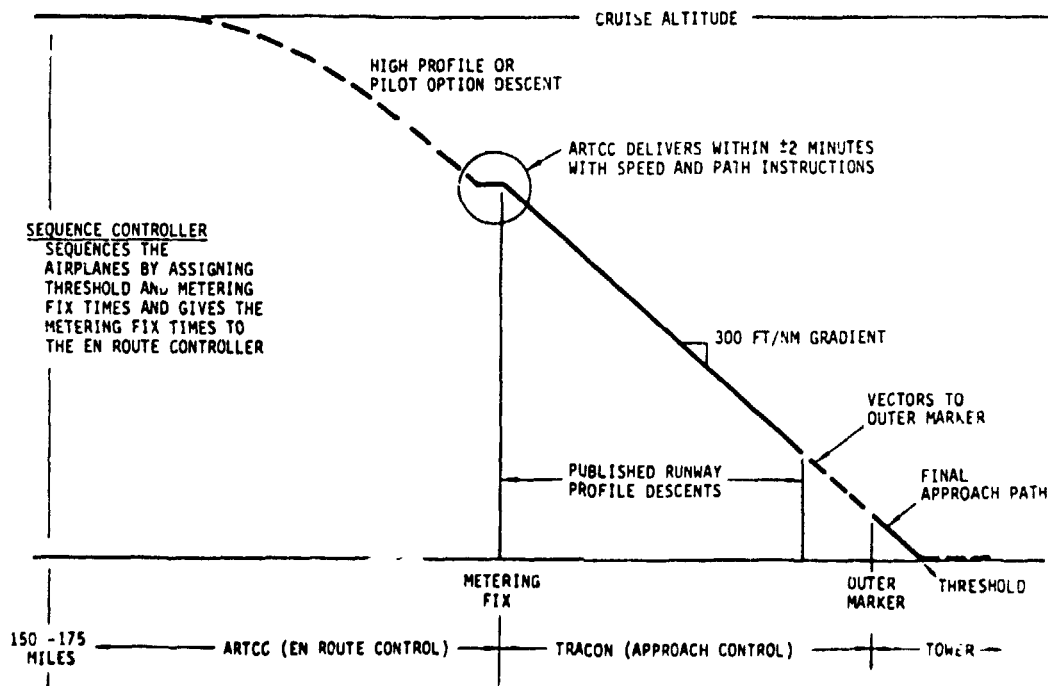

Figure 40. - Current Local Flow Management/Profile Descent Concept

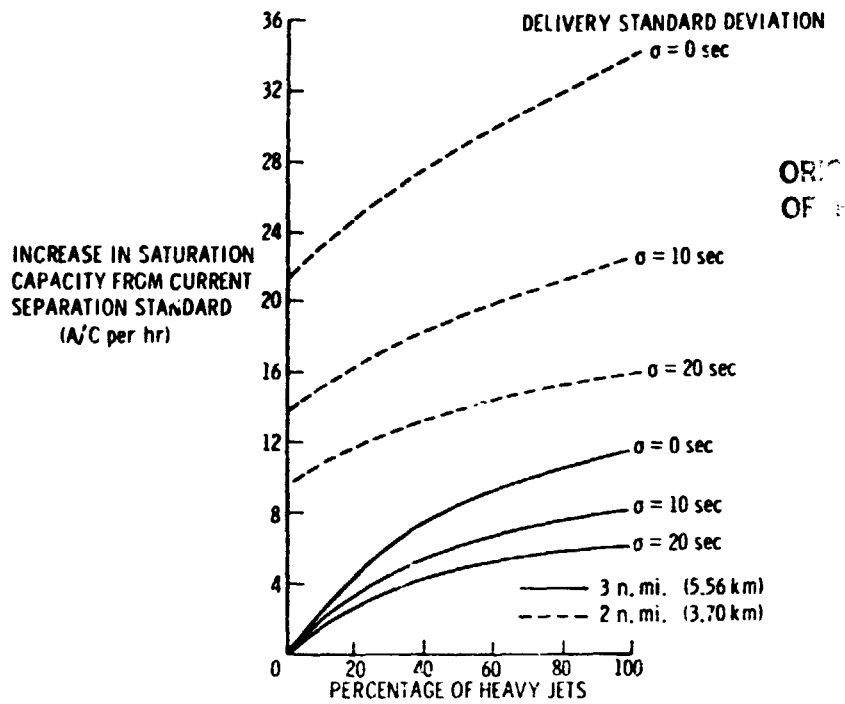

Figure 41. - Capacity Increase Resulting from Reducing Separation to all 2 n. mi. (3.70 km) and to all 3 n. mi. (5.56 km) for Varying Delivery Standard Deviations

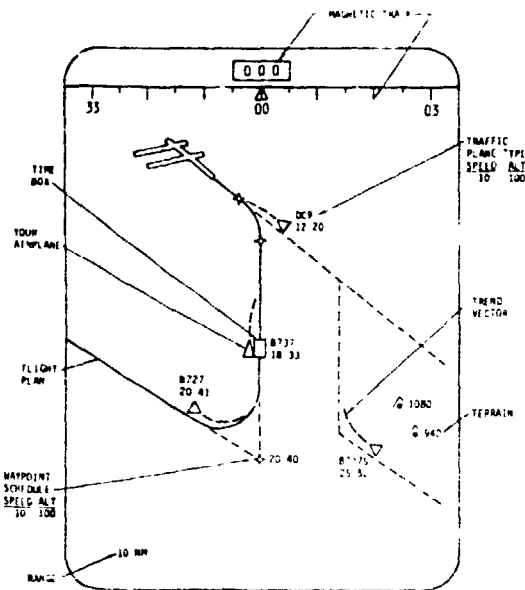

Figure 42. - Traffic Display on EHSI