



## Operational costs induced by fluctuating wind power production in Germany and Scandinavia

**Meibom, Peter; Weber, C.; Barth, R.; Brand, H.**

*Published in:*  
Energy solutions for sustainable development. Proceedings

*Publication date:*  
2007

*Document Version*  
Publisher's PDF, also known as Version of record

[Link back to DTU Orbit](#)

*Citation (APA):*  
Meibom, P., Weber, C., Barth, R., & Brand, H. (2007). Operational costs induced by fluctuating wind power production in Germany and Scandinavia. In L. Sønderberg Petersen, & H. Larsen (Eds.), *Energy solutions for sustainable development. Proceedings* (pp. 196-205). Risø National Laboratory. Denmark. Forskningscenter Risøe. Risøe-R No. 1608(EN)

---

### General rights

Copyright and moral rights for the publications made accessible in the public portal are retained by the authors and/or other copyright owners and it is a condition of accessing publications that users recognise and abide by the legal requirements associated with these rights.

- Users may download and print one copy of any publication from the public portal for the purpose of private study or research.
- You may not further distribute the material or use it for any profit-making activity or commercial gain
- You may freely distribute the URL identifying the publication in the public portal

If you believe that this document breaches copyright please contact us providing details, and we will remove access to the work immediately and investigate your claim.



## **Risø International Energy Conference 2007**

### **Energy Solutions for Sustainable Development**

#### **Presentations**

##### **Session 1 - Future Global Development Options**

Energy Efficiency. Achieving more with less, Stefan Denig, Siemens AG

Energy Implications of Climate Mitigation Policies, Massimo Tavoni, FEEM

Promotion strategies for electricity from renewables in the EU—lessons learned, Reinhard Haas, Vienna University of Technology

##### **Session 2 - Scenarios and Policy Options**

Perspectives of the IDA Energy Year 2006 project, Per Nørgård, Risø National Laboratory, the Technical University of Denmark

Integrated European Energy RTD as part of the innovation chain to enhance renewable energy market breakthrough, Peter Lund, Helsinki University of Technology

Impacts of high energy prices on long-term energy-economic scenarios for Germany, Volker Krey, Dag Martinsen, Peter Markewitz, Research Centre Jülich, Institute of Energy Research - Systems Analysis and Technology, Evaluation (IEF-STE), Jülich, Germany

### **Session 3 – Clean Coal Technologies**

Polygeneration, Thomas Rostrup-Nielsen, HALDOR TOPSOE A/S

### **Session 4 – Bioenergy**

Sustainable bioethanol production combining biorefinery principles and intercropping strategies, Mette Hedegaard Thomsen, Henrik Hauggaard-Nielsen, Anneli Petersson, Anne Belinda Thomsen, Erik Steen Jensen, Risø National Laboratory, the Technical University of Denmark

### **Session 5 - Renewable Energy for the Transport Sector**

Co-ordination of Renewable Energy Support Schemes in the EU, Poul Erik Morthorst and Stine Grenaa Jensen, Risø National Laboratory, The Technical University of Denmark

Bioethanol. Second generation Bio-fuel – close to commercialization. Charles Nielsen, DONG Energy.

Long-term biofuels scenarios: preliminary results from REFUEL –A European Road Map for Biofuels, Henrik Duer, COWI A/S, Denmark

### **Session 6 – Wind**

Upwind. A Wind Research Project under the 6th Framework Programme, Peter Hjuler Jensen, Risø National Laboratory, the Technical University of Denmark

Wind Power Costs in Portugal, Carla Saleiro, Madalena Araújo, Paula Ferreira, Universidade do Minho

Economic and Financial Feasibility of Wind, Energy - Case Study of Philippines, Jyoti Prasad Painuly, UNEP Risø Centre, Risø National Laboratory, the Technical University of Denmark

### **Session 7 – Solar and Wave Energy**

Wave Energy – challenges and possibilities, Per Resen Steenstrup, WaveStar Energy

### **Session 8 – Systems with High Level of Renewable Energy**

Operational costs induced by fluctuating wind power production in Germany and Scandinavia, Peter Meibom, Risø National Laboratory, Technical University of Denmark, Christoph Weber, University Duisburg-Essen, Rüdiger Barth & Heike Brand, IER, University of Stuttgart

### **Session 9 – End Use Technologies and Efficiency Improvements**

A cooling system for buildings using wind energy, Hamid Daiyan, Azad University-Semnan Branch, Iran

Energy Demand Patterns. The Effects Substitution and Productivity, Nico Bauer  
Potsdam Institute for Climate Impact Research (PIK).

### **Session 10 – Systems Aspects – Distributed Production**

STREAM: A Model for a Common Energy Future, Peter Markussen, DONG Energy

Vanadium redox-flow batteries –Installation at Risø for characterisation measurements, Henrik Bindner, Risø National Laboratory, the Technical University of Denmark

Centralised and decentralised control –a power system point of view, Oliver Gehrke and Stephanie Ropenus, Risø National Laboratory, the Technical University of Denmark, Philippe Venne (UQAR)

### **Session 11 - Low Level CO<sub>2</sub> Strategies for Developing Countries**

Assessing the Role of Energy in Development and Climate Policies in Large Developing Countries, Amit Garg and Kirsten Halsnæs, Risø National Laboratory, the Technical University of Denmark

Sustainable Transport Practices in Latin America, Jorge Rogat and Miriam Hinojosa, UNEP Risø Centre, Risø National Laboratory, the Technical University of Denmark

### **Session 12 – Carbon Capture and Storage Contribution to Stabilization**

Environmental Analysis of Coal-based Power Production with Amine-based Carbon Capture, W. Kuckshinrichs, J. Nazarko, A. Schreiber, P. Zapp, Institute of Energy Research, Systems Analysis and Technology Evaluation (IEF-STE), Fuel Cells (IEF3), Forschungszentrum Jülich GmbH

### **Session 13 – Hydrogen Economy**

Solid Oxide Electrolysis for Fuel Production, Sune D. Ebbesen, Anne Hauch, Søren H. Jensen, and Mogens Mogensen, Risø National Laboratory, the Technical University of Denmark

### **Session 14 – Fuel Cells**

Use of Alternative Fuels in Solid Oxide Fuel Cells, Anke Hagen, Risø National Laboratory

Fuel Cell - Shaft Power Packs, Frank Elefsen, Danish Technological Institute

### **Session 15- R&D Priorities**

Overview of U.S. DOE's Coal RD&D Programs, Scott M. Smouse, National Energy Technology Laboratory, Office of Fossil Energy, U.S. Department of Energy

The UK Energy Research Atlas: A Tool for Prioritising and Planning Energy R&D, Jim Skea, Research Director, UKERC

European and global perspectives for CCS, Martine Uytterlinde, Heleen Groenenberg, Energy Research Centre of the Netherlands

Solar Energy, Status and Perspectives, Peter Ahm, Director, PA Energy A/S



# **Energy Efficiency**

## **Achieving more with less**

Risø International Energy Conference  
Roskilde, 22 May 2007

**Stefan Denig, Siemens AG**

# Challenges:

## Climate change is a fact, threatening humans and biosphere

### Climate change and impact

<p><b>Climate change ...</b></p>	<ul style="list-style-type: none"> <li>Anthropogenic <b>greenhouse gas emissions</b> <sup>1)</sup> from fossil fuel burning and land use <b>shift the radiation balance</b> of the earth and cause warming</li> <li>Scientific consensus that doubling of CO<sub>2</sub> from pre-industrial levels (280 ppm) by non-acting till 2035 <b>causes unacceptable global temperature increase</b></li> <li><b>Feedback amplifies warming</b></li> </ul>	<p><b>Effect of greenhouse gases</b></p>										
<p><b>... threatens humans and biosphere</b></p>	<ul style="list-style-type: none"> <li>Melting may cause <b>flooding of &gt;4 million km<sup>2</sup> affecting &gt; 300 million people</b></li> <li><b>Spread of diseases</b> expected (Malaria, Dengue fever etc.)</li> <li>More frequent <b>extreme weather conditions jeopardize crops and living conditions</b></li> <li><b>15-20% of species face extinction</b> at only 2°C warming</li> </ul>	<p><b>Urgent need for action</b></p> <table border="1"> <caption>Temperature change in °C</caption> <thead> <tr> <th>Year</th> <th>Temperature Change (°C)</th> </tr> </thead> <tbody> <tr> <td>1850</td> <td>0</td> </tr> <tr> <td>Today</td> <td>0.6</td> </tr> <tr> <td>2030</td> <td>1.9</td> </tr> <tr> <td>2100</td> <td>5.0</td> </tr> </tbody> </table>	Year	Temperature Change (°C)	1850	0	Today	0.6	2030	1.9	2100	5.0
Year	Temperature Change (°C)											
1850	0											
Today	0.6											
2030	1.9											
2100	5.0											

1) Carbon dioxide, methane, nitrous oxides, etc.

Most likely

# Challenges: Business as usual will be more costly than action

- Long-term cost of inaction (Business as usual) and action

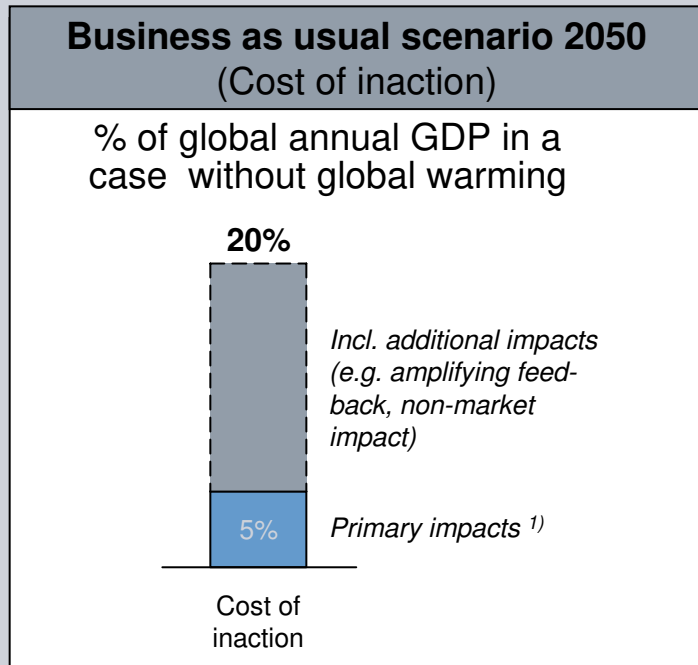

**Climate change has serious impacts on growth and development**

1) Assumes 5°C temperature increase by 2050  
Source: Stern Review

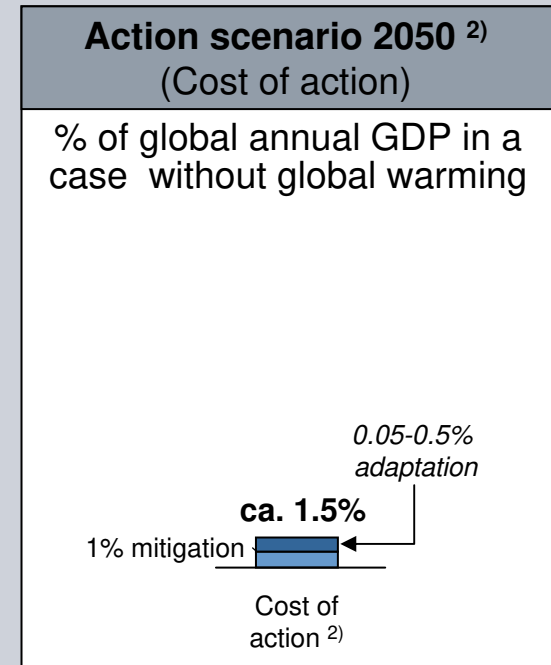

**The costs of stabilizing the climate are significant but manageable**

2) Keep GHG between 500 and 550 CO<sub>2</sub>e ppm

# Challenges: Highest CO<sub>2</sub> emissions in North America and Asia

Population size times average annual per capita emissions. The size of the circles indicates the product of these variables and therefore the region's total CO<sub>2</sub> emissions in 2000 and 2020

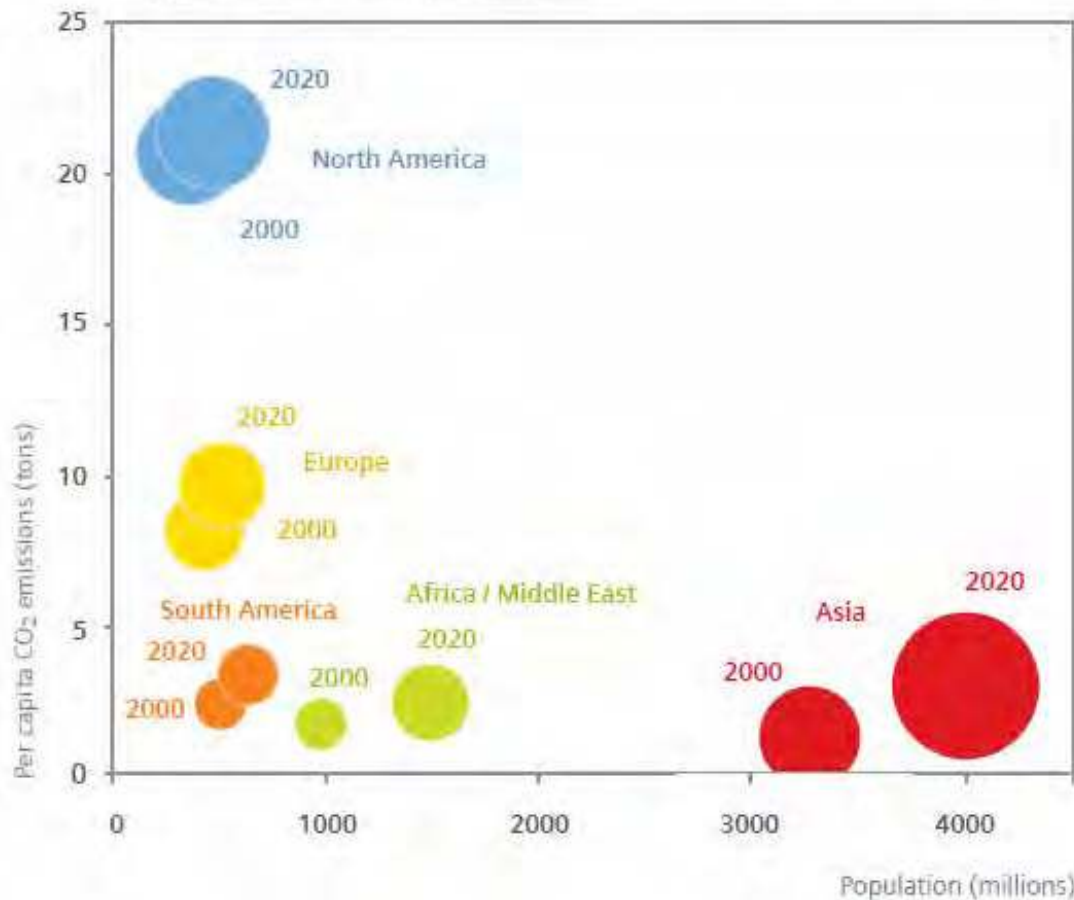

Source: EC 2003

## Development of CO<sub>2</sub> emissions

- GHG emissions – responsible for global warming – will increase
- Level of GHG emissions will remain high in industrialized countries, but will increase particularly in emerging countries

# Challenges:

## Rapidly increasing energy consumption, mainly in BRIC countries

Energy consumption in different world regions, 2002-2025

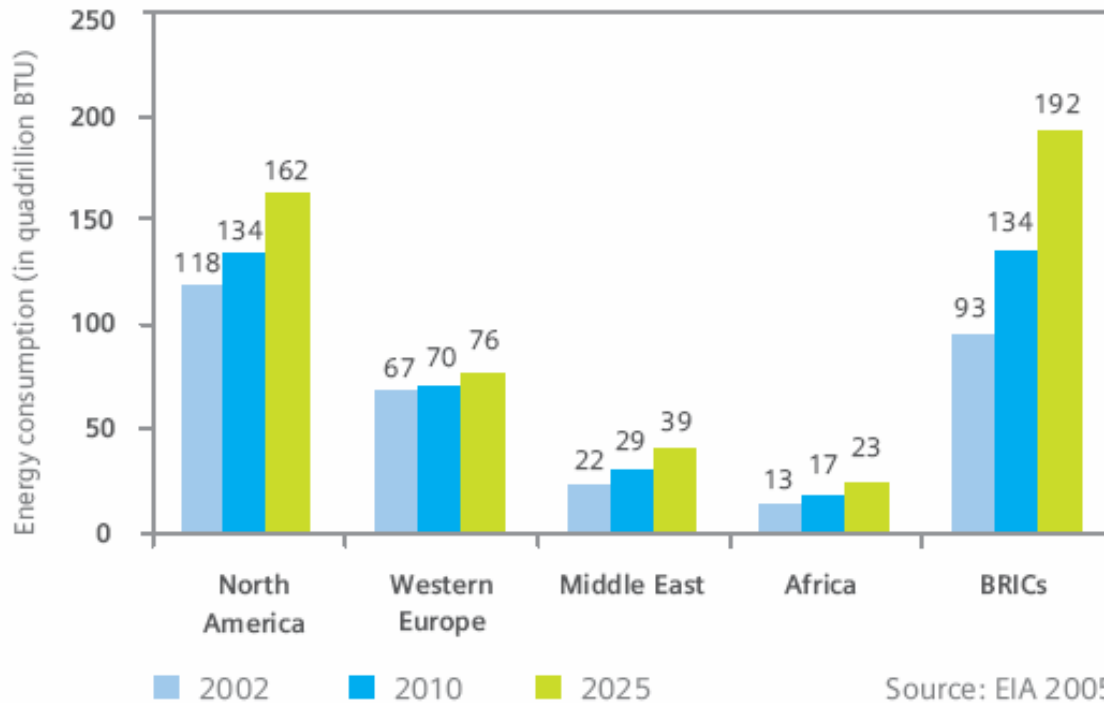

### Most rapid growth expected in non-OECD countries

- Fastest growth evident in BRIC economies
- Growth driven by industrialization and rising per capita consumption, although per capita consumption remains at low level

# Challenges:

## Large growth of world final energy consumption



### Growing consumption of natural resources

- Energy consumption is rising dramatically
- Fossil fuels to remain of vital importance
- Ongoing growth in the demand for oil, gas and coal

# Challenges: Coal will last the longest

Statistical ranges of fossil and nuclear fuels

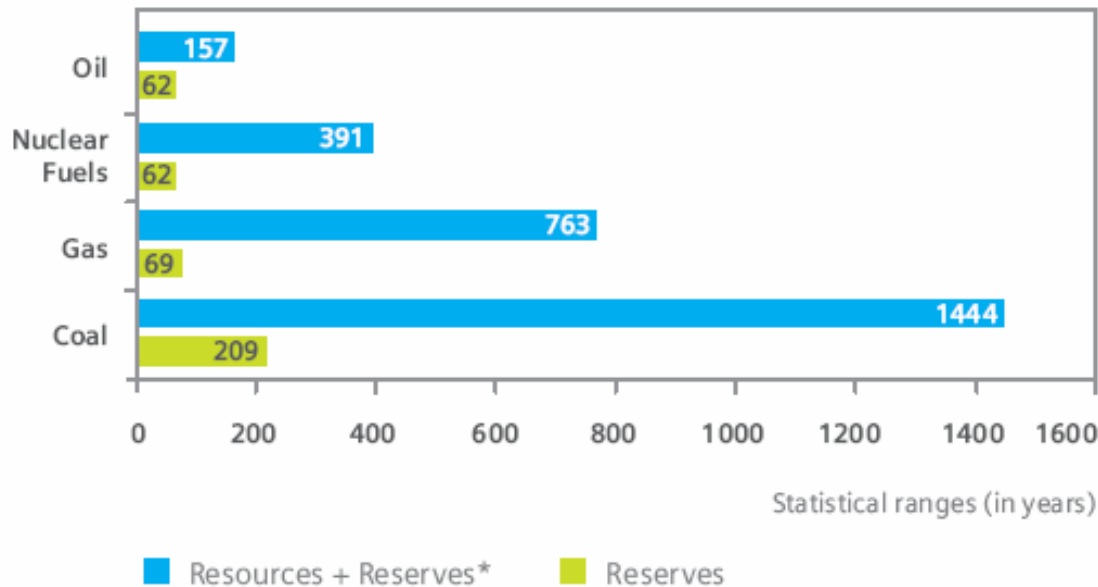

\* Reserves: The amount currently technologically and economically recoverable.

Resources: Quantities technically or economically not (yet) recoverable or not yet proven.

Source: Dresdner Bank 2005

## Ensuring the supply of resources

- Improve production infrastructure in order to assure supply
- Manage political crisis
- Promote diversification in order to guarantee long-term supply
- Promote renewable energy use on individual level

# Challenges:

## Growing relevance of energy security

### Political implications

- Energy supply questions are entering the political agenda:  
Nationalization of energy industries (e.g. in Russia, Bolivia, Venezuela)
- China: Energy supply is vital for economic development (e.g. contracts with Iran to secure supply create dependencies and influence diplomatic behavior)
- Inter-regional trade of energy resources increasingly important (international attention will focus on maintaining the security of sea-lanes and pipelines)

### Managing political conflict

- Challenge of fair resource supply needs to be addressed
- Conflicts have to be prevented





# Challenges:

## Energy diversity will not change fundamentally in the next 10 years

Growth of energy use and percentage shares of energy sources, 2002-2015

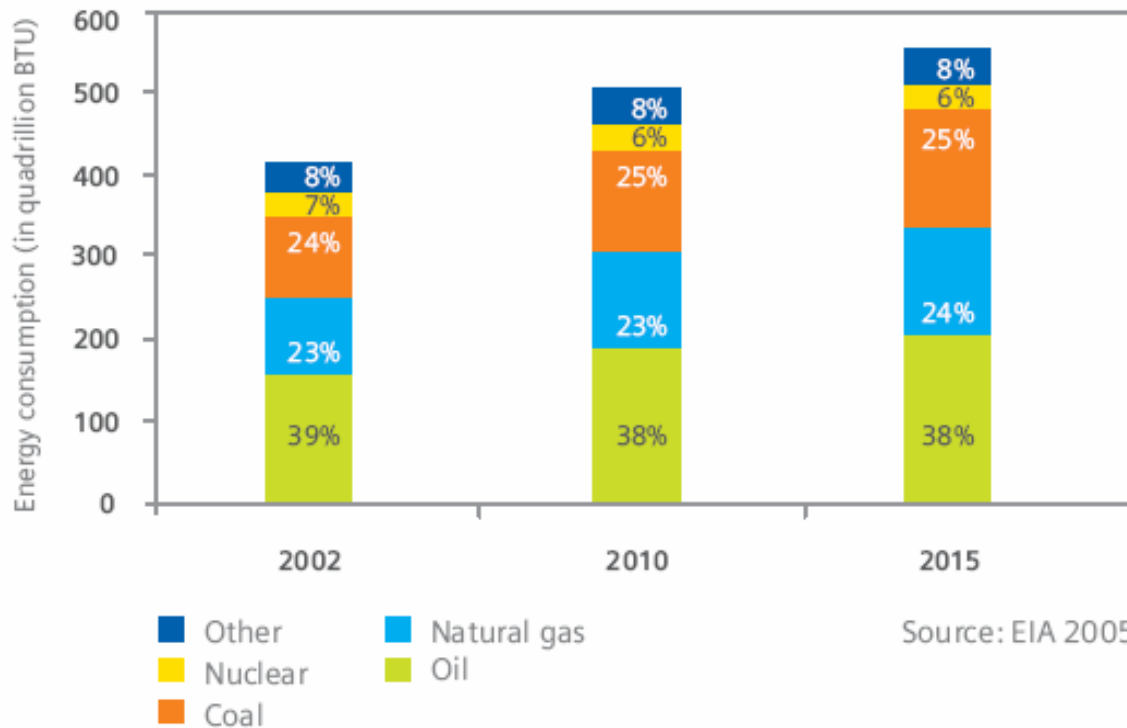

### Increasing importance of energy diversity

- Energy diversity will have to be a more prominent issue on the political agenda
- Use of renewables to expand diversity of supply
- Development of other alternative energy sources

# Solutions: Achieving more with less

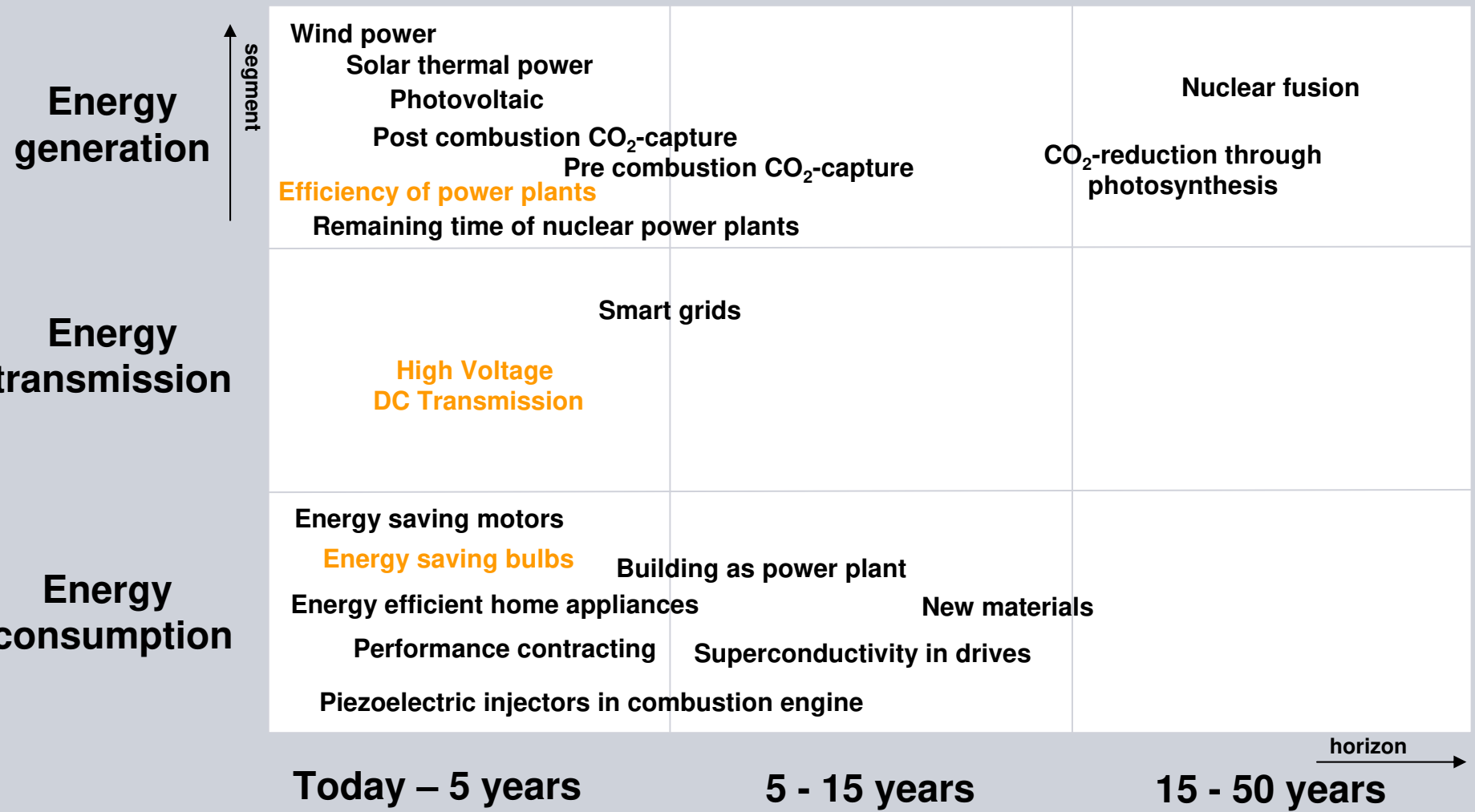

# Solutions:

## Energy generation - Efficiency of up to 60% is possible

### World's largest and most efficient gas turbine:

- Can supply electricity to 620,000 three-person households or a city the size of Barcelona, Spain
- Combined-cycle power plant with this gas turbine will have an efficiency of over 60% – world record
- In comparison with a coal-fired power plant (average efficiency 38%), it saves 2.8 million tons of CO<sub>2</sub> per year – more than Siemens emits



### Shanghai – Efficient coal plant Waigaoqiao:

- China's largest and most modern coal-fired power plant, two 900 MW blocks installed, third in preparation
- Efficiency 42 percent (scheduled to rise to 45), highest of its kind in China (average efficiency of black coal power plants in Germany: 37 percent)
- Sets also new standards in low-level nitrogen oxide and sulfur dioxide emissions



# Solutions:

## Energy transmission – HVDC enables use of remote sources

### Low loss connection of remote power sources:

- Low energy loss in long distance power transmission (e.g. coal and hydro power (e.g. China), offshore wind parks in Europe)
- Opens up large renewable power potential worldwide
- Allows for decoupling of power generation and load centers
- Flexibility in power sourcing and trading

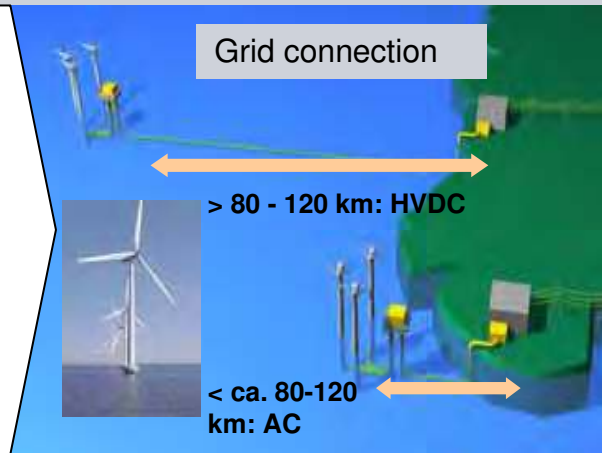

## Solutions:

### Energy consumption – Huge potential for energy savings

#### New Siemens trains use 30% less energy than Oslo's current trains:

- Less energy needed by feeding braking energy back into power grid and by using mostly aluminum for the lightweight body design
- Comprehensive disposal concept: 95% of each train can be utilized (85% through recycling, 10% through burning)
- Over their entire lifecycle the trains burden the environment with just 2.6 grams of CO<sub>2</sub> per kilometer traveled and per ton of vehicle weight – a very low value for metros (2.0 grams for actual train operation, depending on energy mix)



#### Energy saving bulbs use 80% less electricity:

- Lighting accounts for 19% of power demand worldwide
- Life of energy saving bulbs is up to 15 times longer than life of conventional bulbs; LED's life is up to 50 times longer
- Savings per energy saving bulb and LED: several hundred euros p.a. and 0.5 t of CO<sub>2</sub>



# Increasing awareness: Environment in top tier of megacities' infrastructure priorities

## Need for Investment

Average % of "Very High" Across All Cities (522 key decision makers in the 25 largest cities worldwide)

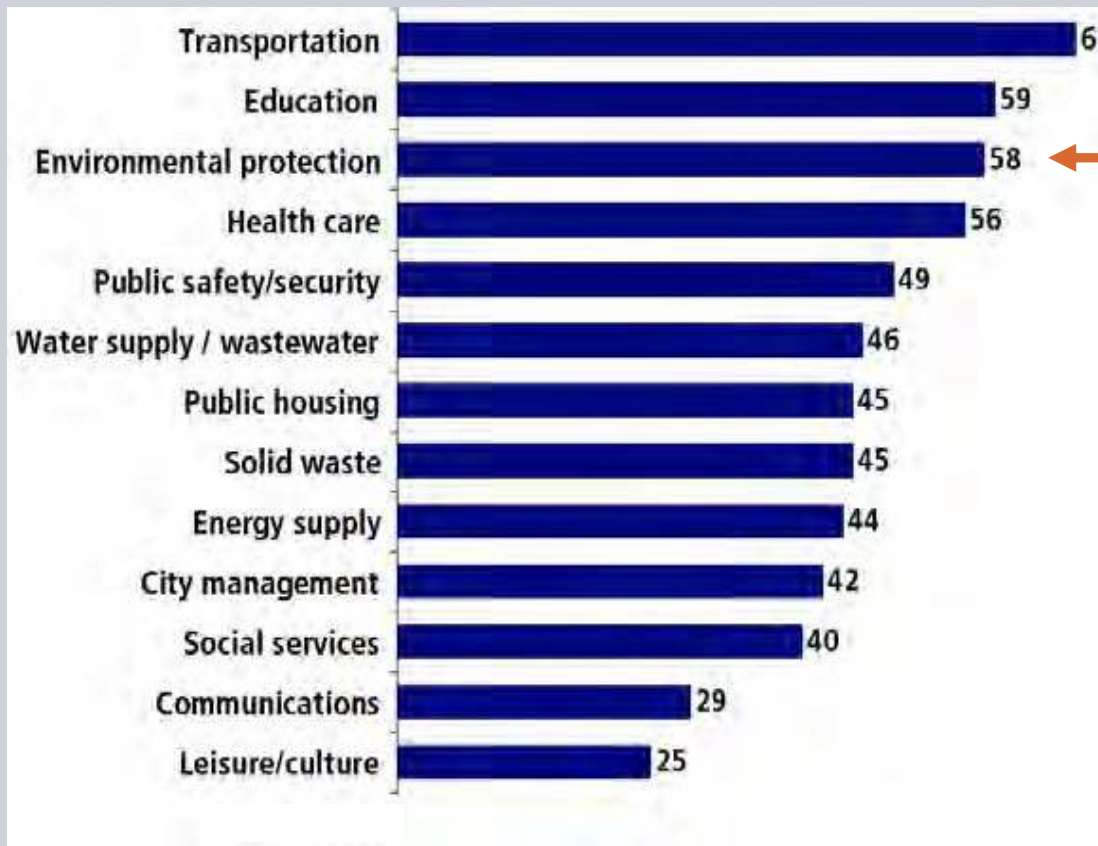

Source: Siemens Megacity Report 2007

Copyright © Siemens AG 2007. All rights reserved.

# Increasing awareness: Environment matters...

## Mass transit is the priority

Predicted by transport experts

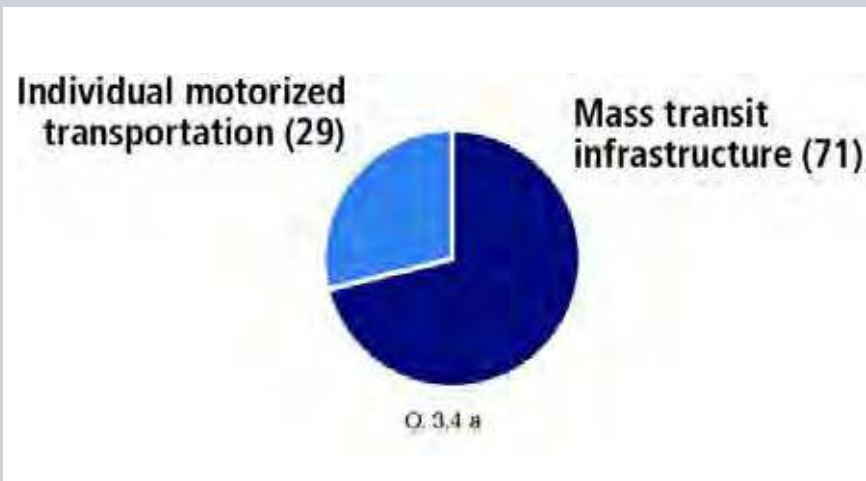

Source: Siemens Megacity Report 2007

## Strong role for renewables

Predicted by electricity experts

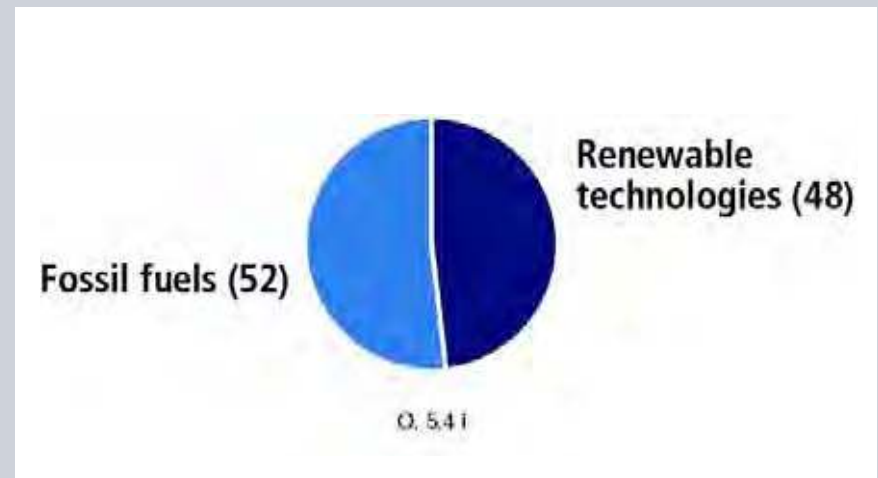

# Increasing awareness: ... but may be sacrificed for growth

Views of knowledgeable stakeholders

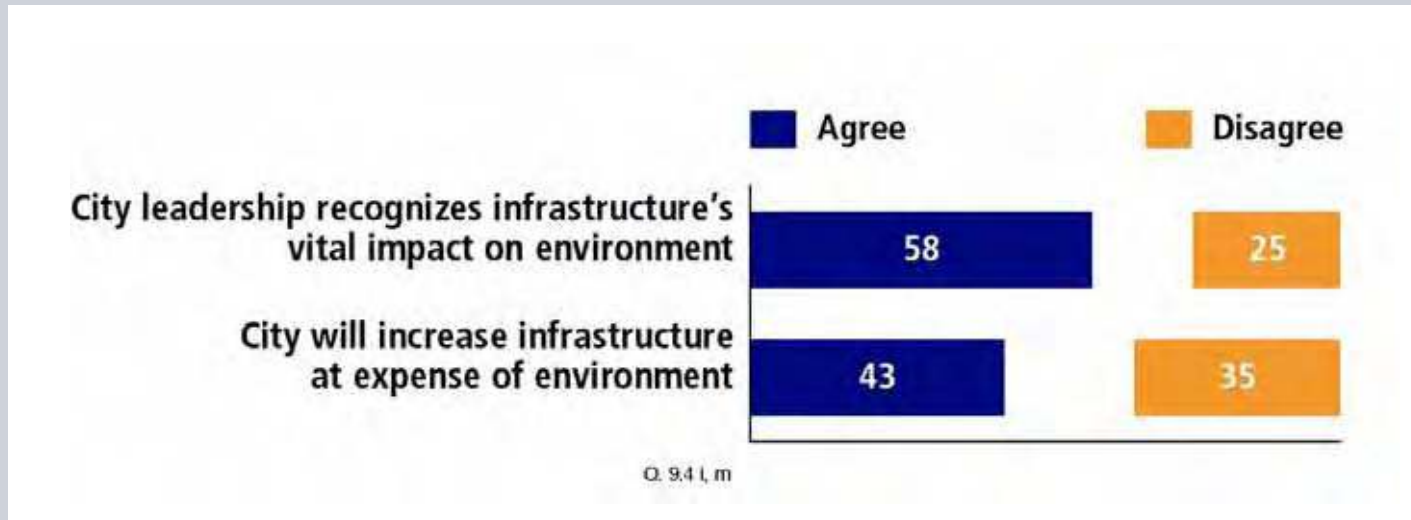

Source: Siemens Megacity Report 2007



# The efficiency champion: How to reduce megacities' energy consumption and CO<sub>2</sub> emissions with technolog. innovations

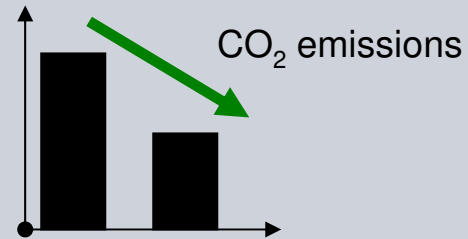
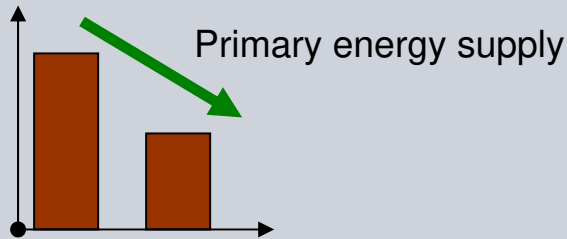

Siemens' total emissions:  
2.7 million tons in 2005

# Energy balance-sheet of a virtual German megacity – What are the levers to reduce energy consumption?

10 million inhabitants, energy data from 2004

Energy-related CO<sub>2</sub> emissions  
106 million tons of CO<sub>2</sub> per year

Total primary energy supply  
1750 PJ per year

Losses during energy generation and distribution as well as consumption in the energy supply chain:  
630 PJ = 36%

Site energy consumption:  
1120 PJ per year

**Industry and business**  
470 PJ = 42%

**Households**  
330 PJ = 29,5%

**Transportation**  
320 PJ = 28,5%



**20% of energy needed as electricity.  
Equals 38% of primary energy!**

**28% of energy needed as motor fuels  
(20% for passenger cars)**

**58% of energy needed for heating!**

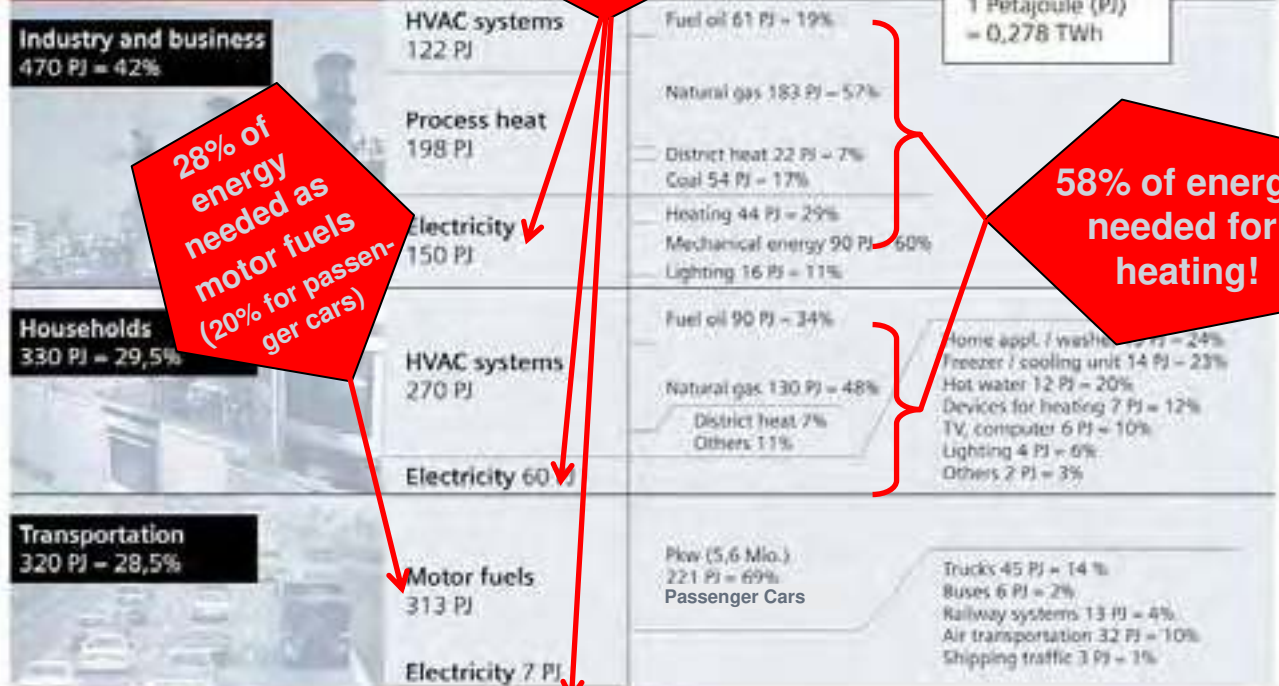

1 Petajoule (PJ)  
= 0,278 TWh

# Possible scenario of tomorrow's megacity

## Virtual German Megacity – tomorrow

Many measures are realized regarding efficiency increase and energy savings

**51% less primary energy consumption, 51% less CO<sub>2</sub> emissions\***

Site energy consumption today: 1120 PJ per year

More efficient and energy-saving systems

Lower losses of primary energy

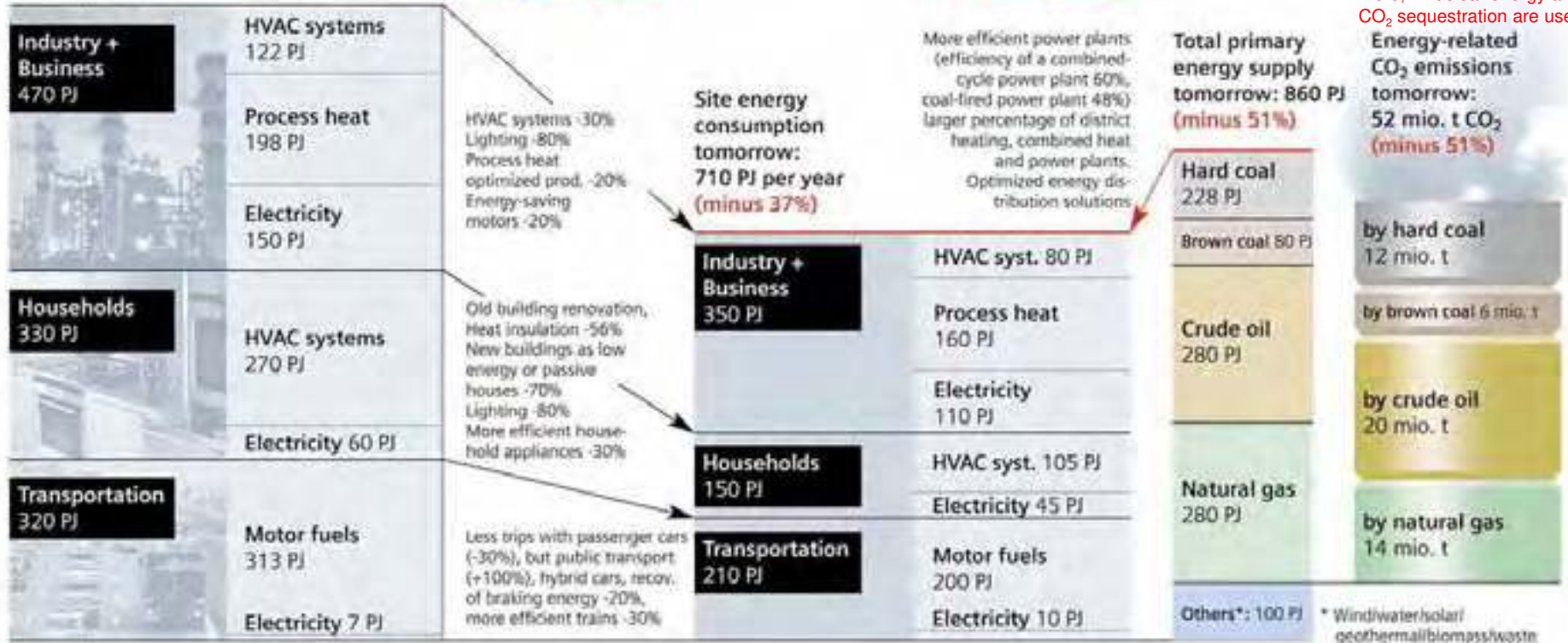

\*can be reduced even more, if nuclear energy and CO<sub>2</sub> sequestration are used.

## **Energy Implications of Climate Mitigation Policies**

Riso International Energy Conference 2007, 22 May 2007

Massimo Tavoni, FEEM

- The WITCH model
- Cost-benefit glimpse
- Climate mitigation policies
  - energy
  - costs vs delaying
  - uncertainty



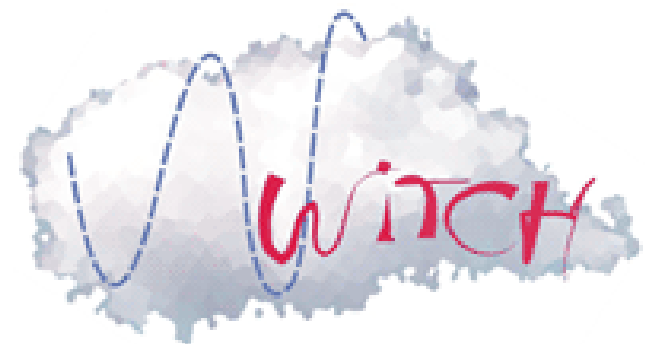

A World Induced Technical Change Hybrid Model

# WITCH

## World Induced Technical Change Hybrid model

Bosetti V., C. Carraro, M. Galeotti, E. Massetti and M. Tavoni, (2006), "WITCH: A World Induced Technical Change Hybrid Model", *The Energy Journal*, Special Issue. Hybrid Modeling of Energy-Environment Policies: Reconciling Bottom-up and Top-down, 13-38.

Hybrid I.A.M.:

- **Economy:** Top-down optimal growth (inter-temporal)
- **Energy:** Energy sector detail (technology scenarios)
- **Climate:** Damage feedback (global variable)

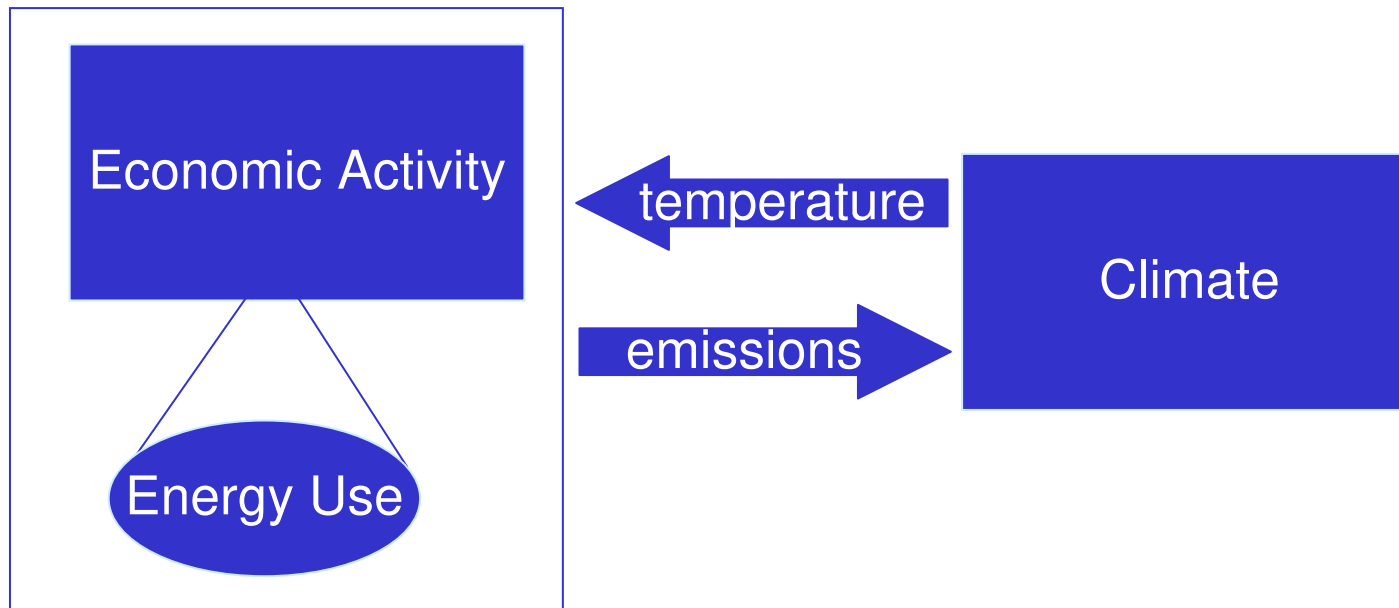

Two solutions:

- **Cooperative** (world best)
- **Non-cooperative** (Nash), interactions among regions on:
  - Environmental externality (carbon)
  - Exhaustible resources (oil, gas, coal, uranium)
  - Technological spillover
  - Trade of emission permits



# C.B.A. non-coop vs coop

# World Carbon Emissions

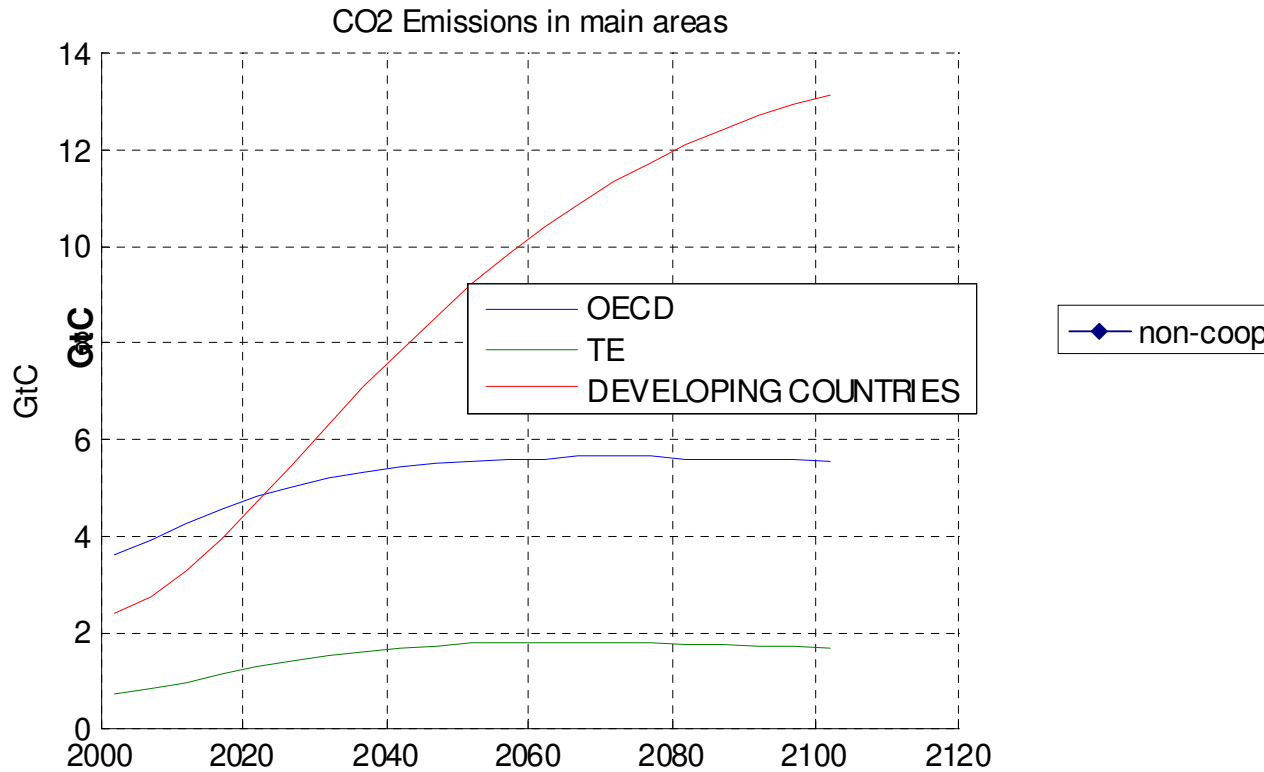

# World Carbon Emissions

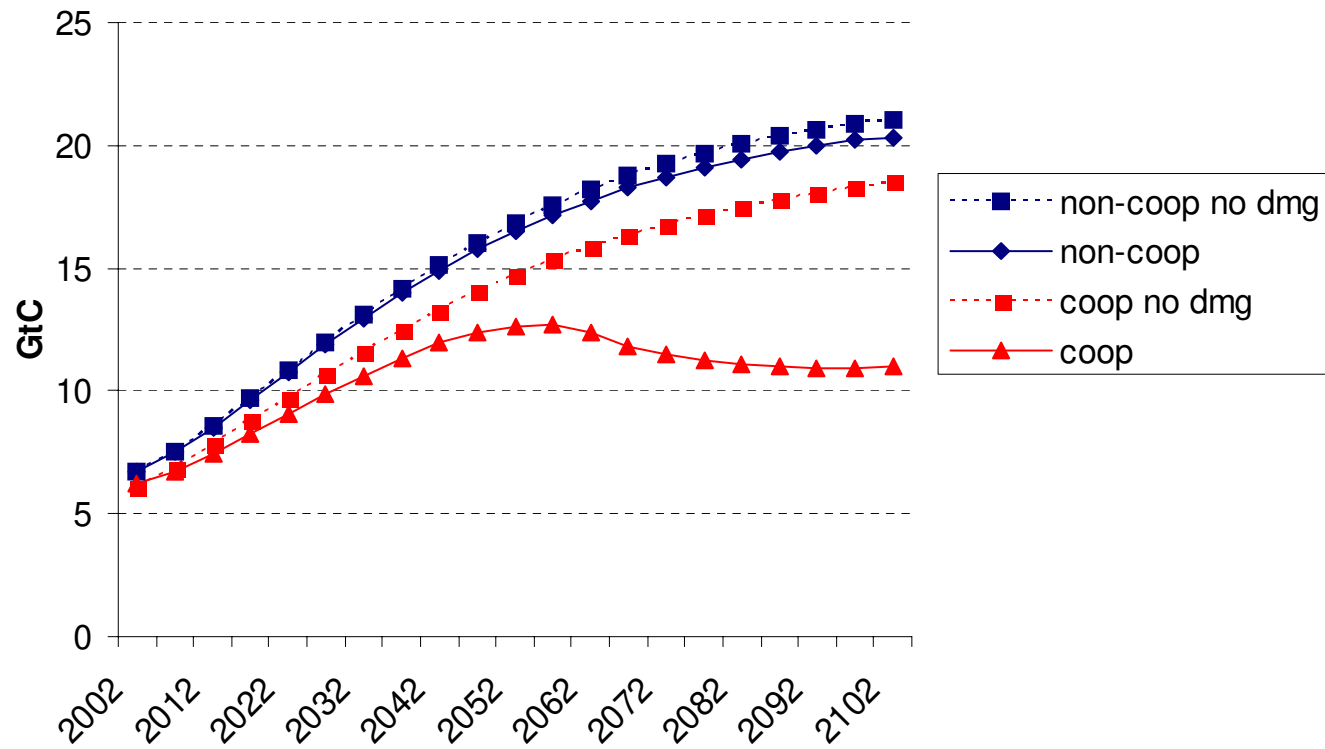

# CO<sub>2</sub> Mitigation: C.E. Analysis

# Mitigation Target: 450 and 550 ppmv

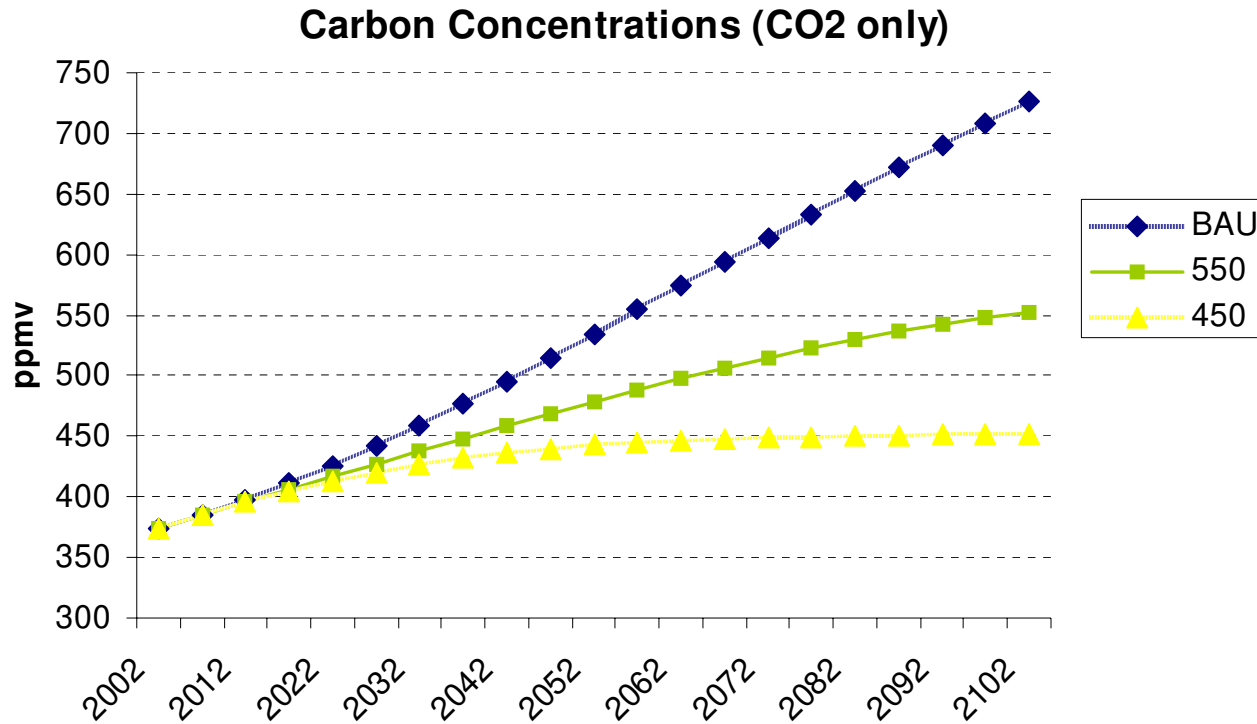

# Mitigation Target: 450 and 550 ppmv

## World Industrial Carbon Emissions (GtC)

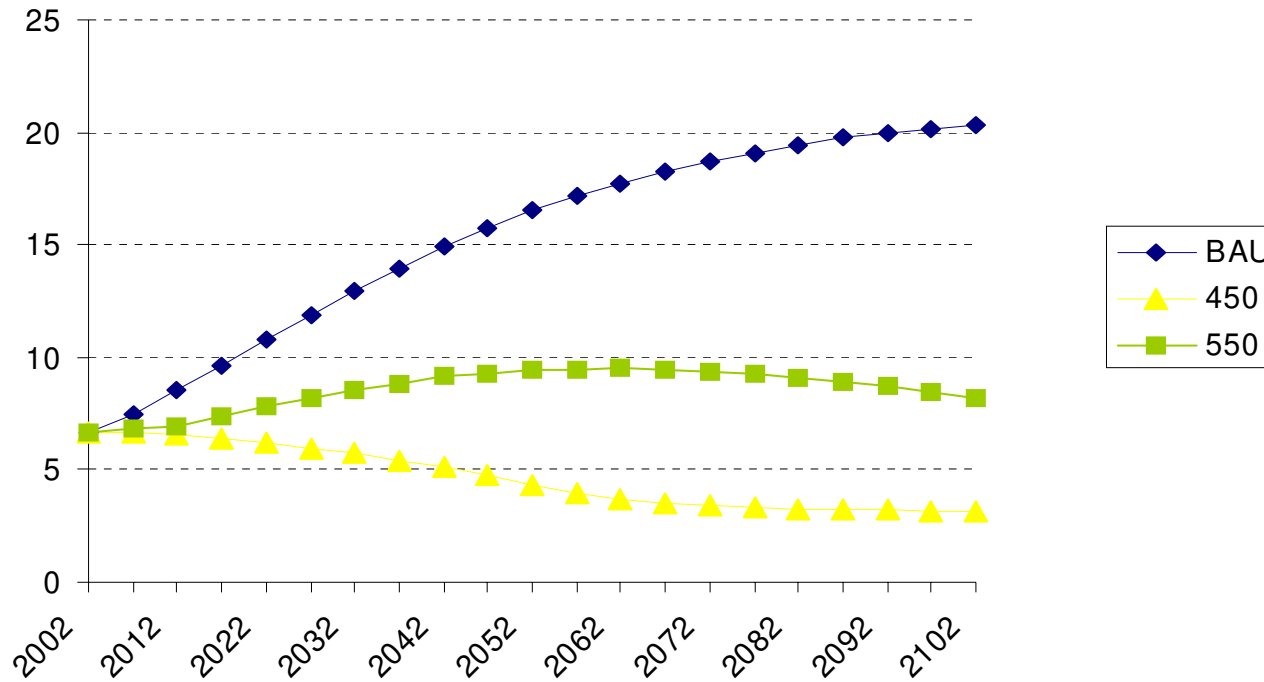

Trajectories in the energy intensity/carbon intensity  
wrt 2002

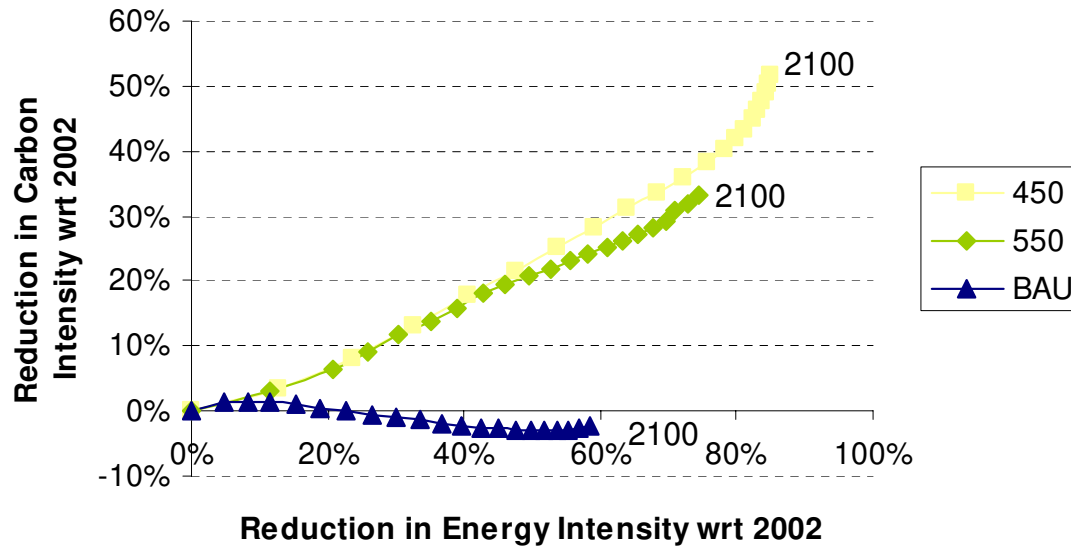

550ppmv

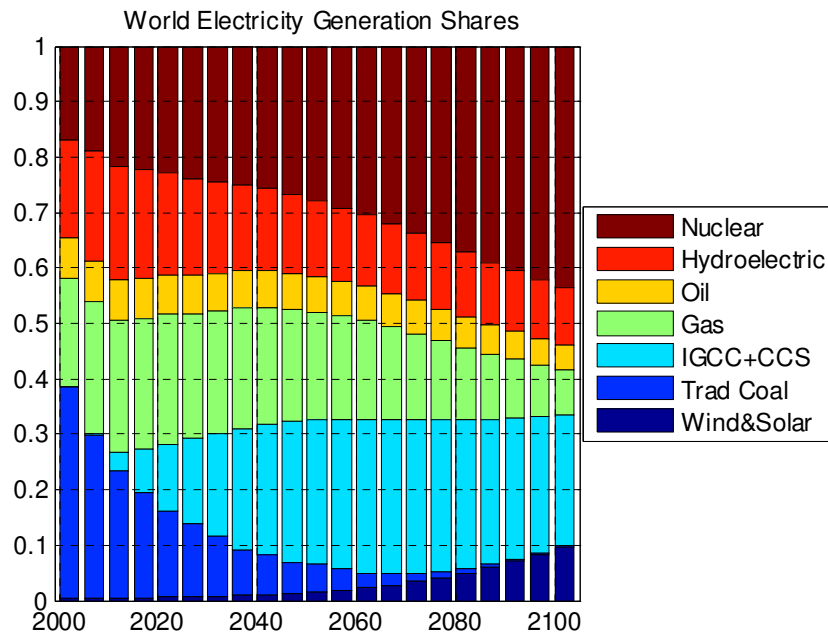

450ppmv

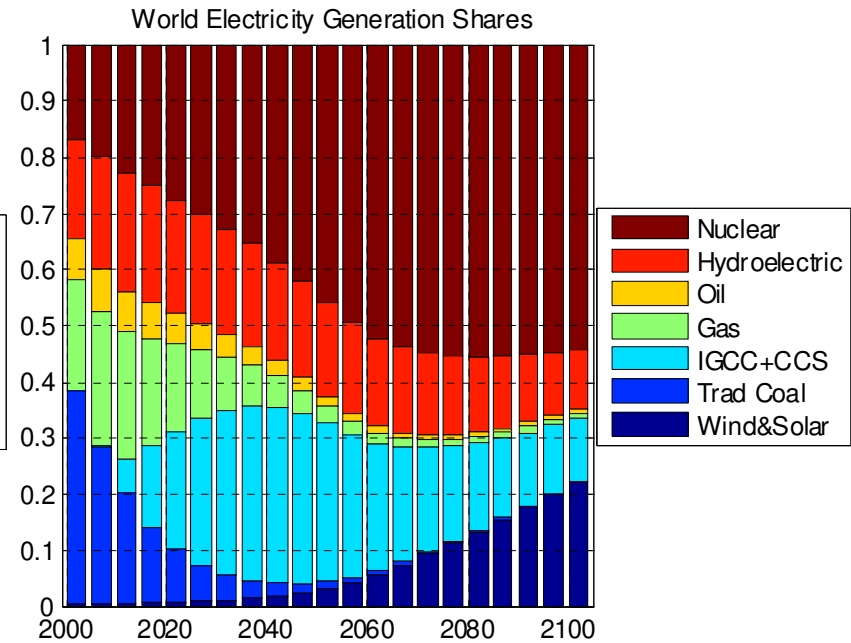



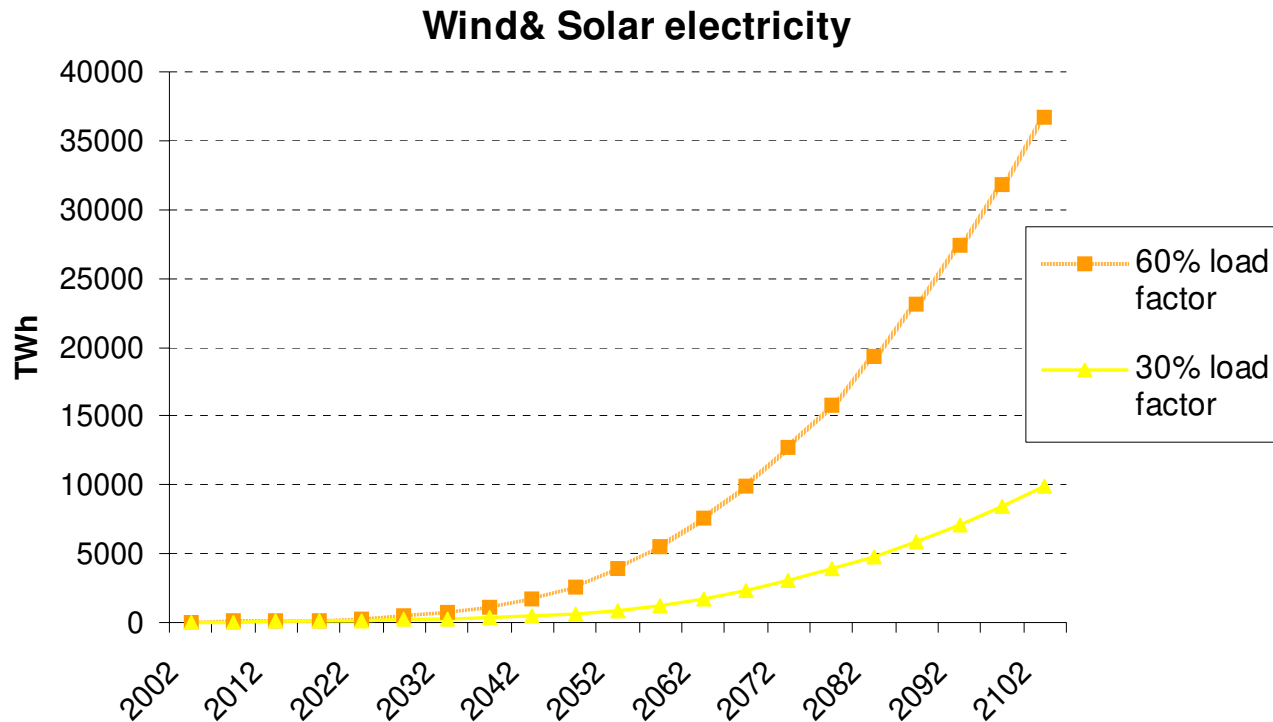

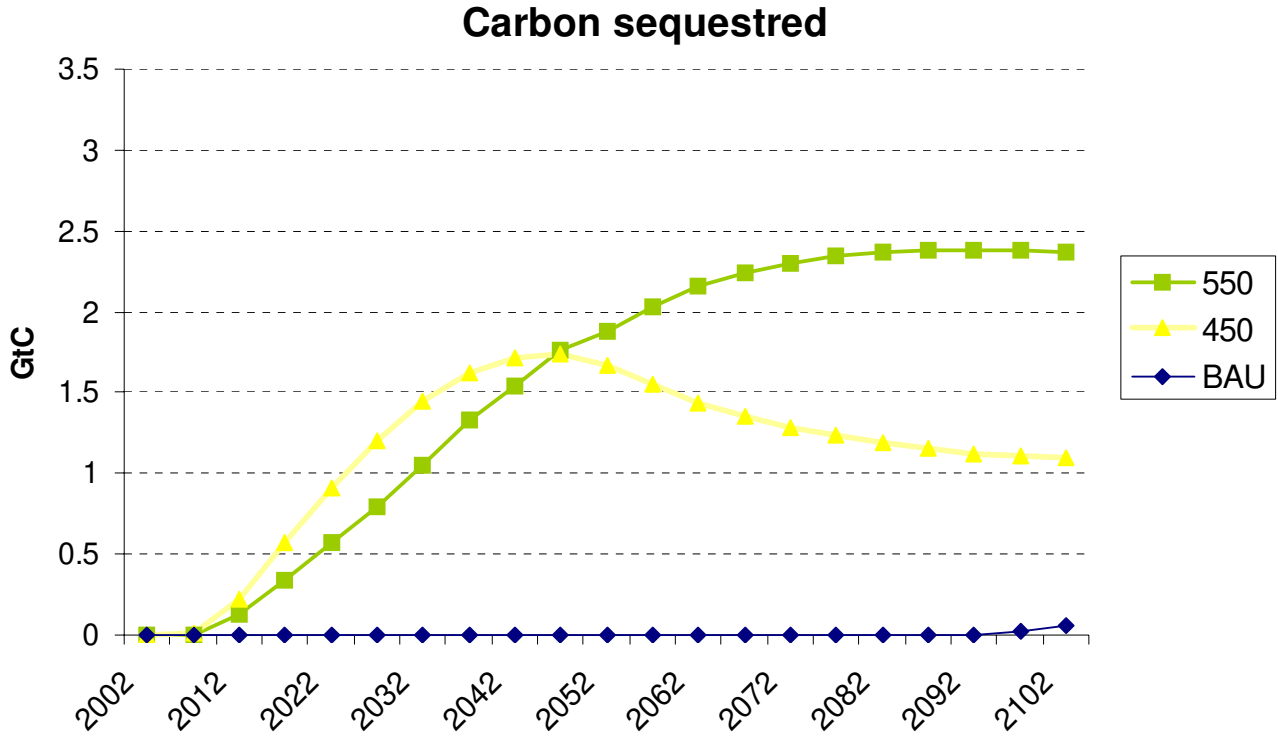

# CCS: effect of capture rate in a 450ppmv

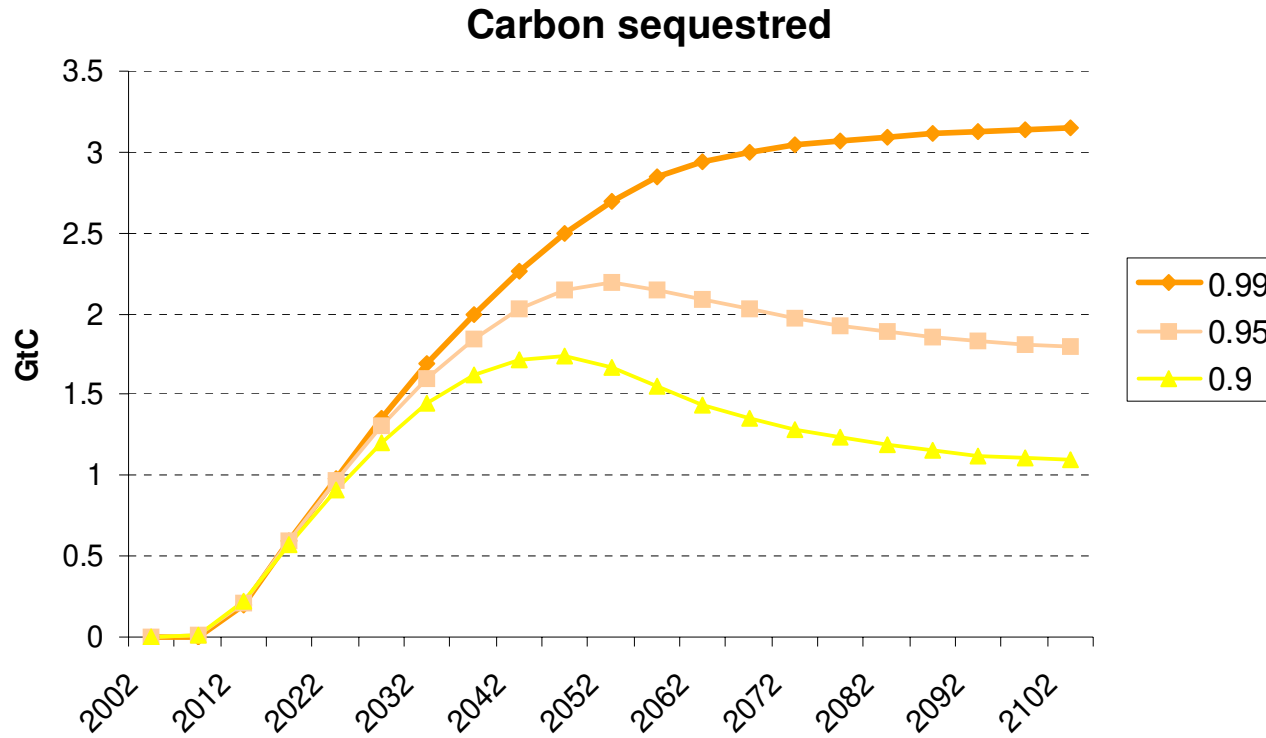

# CCS: effect of leakage rate in a 450ppmv

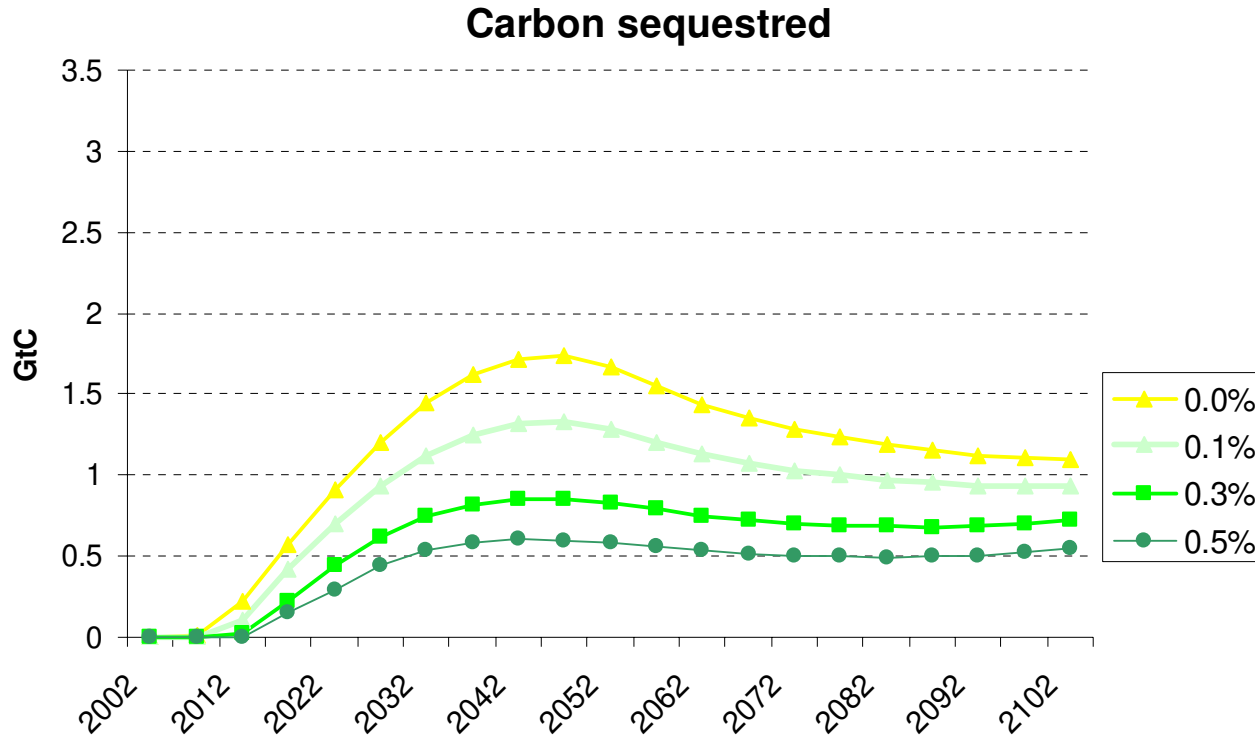

# Endogenous Technical Change

## LbD: Investment cost of wind&solar plants wrt to BAU

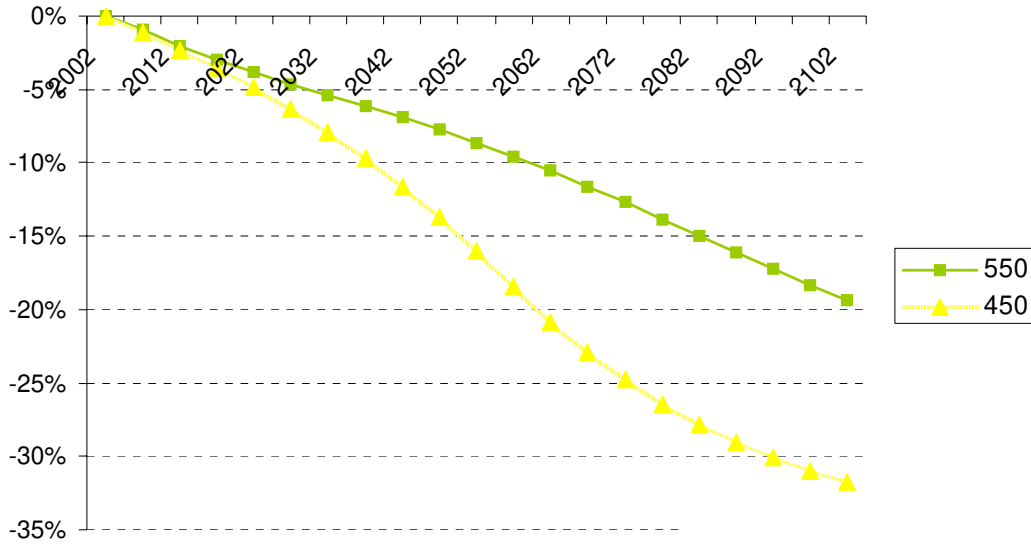

## Energy R&D investments

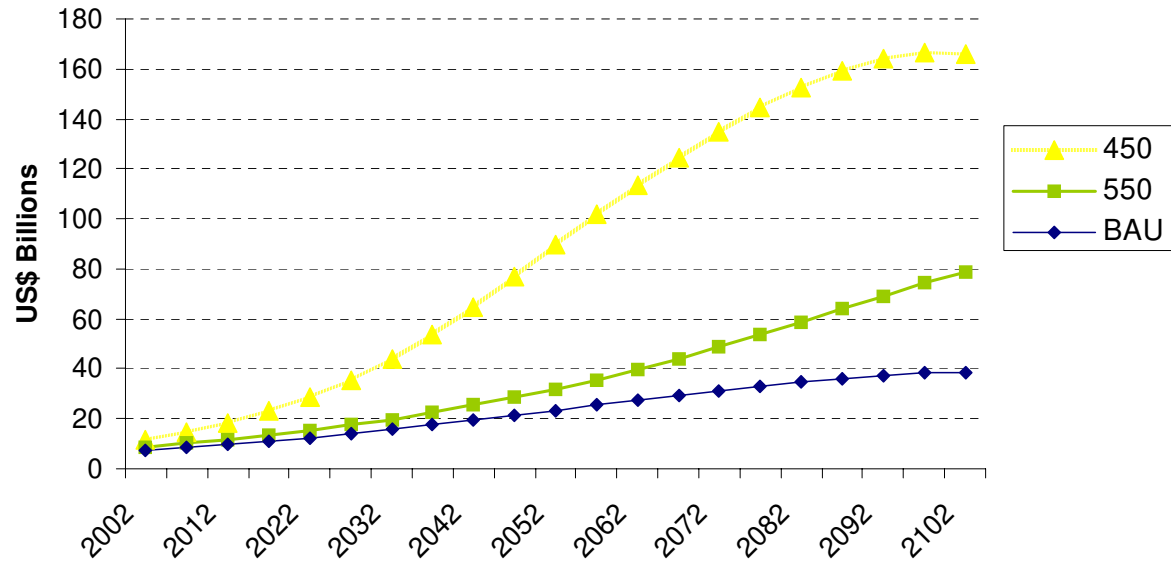

# Policy Costs

Costs of procrastination: 3% discounted

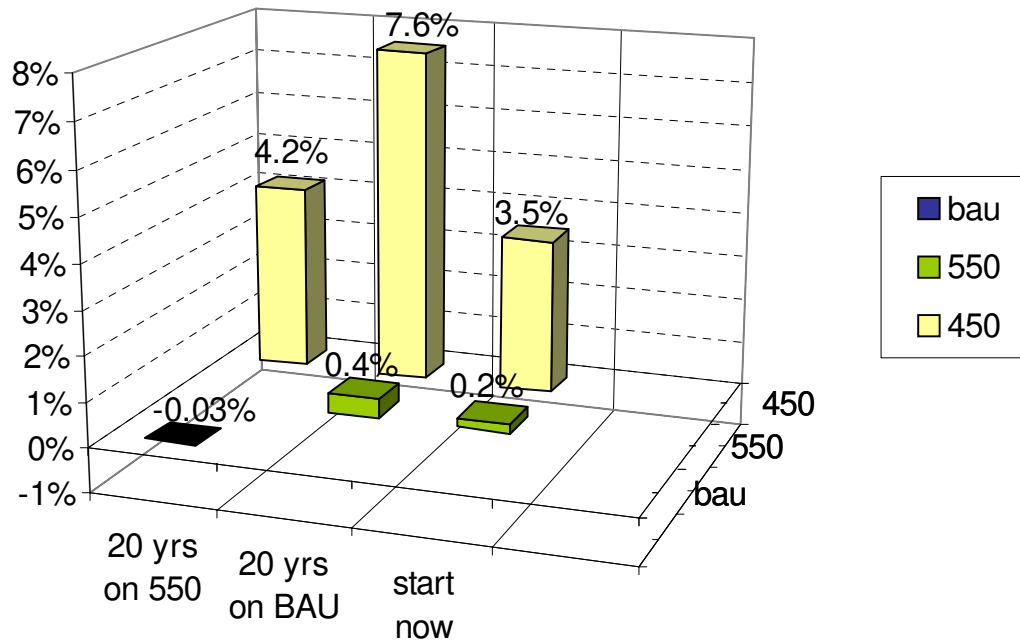

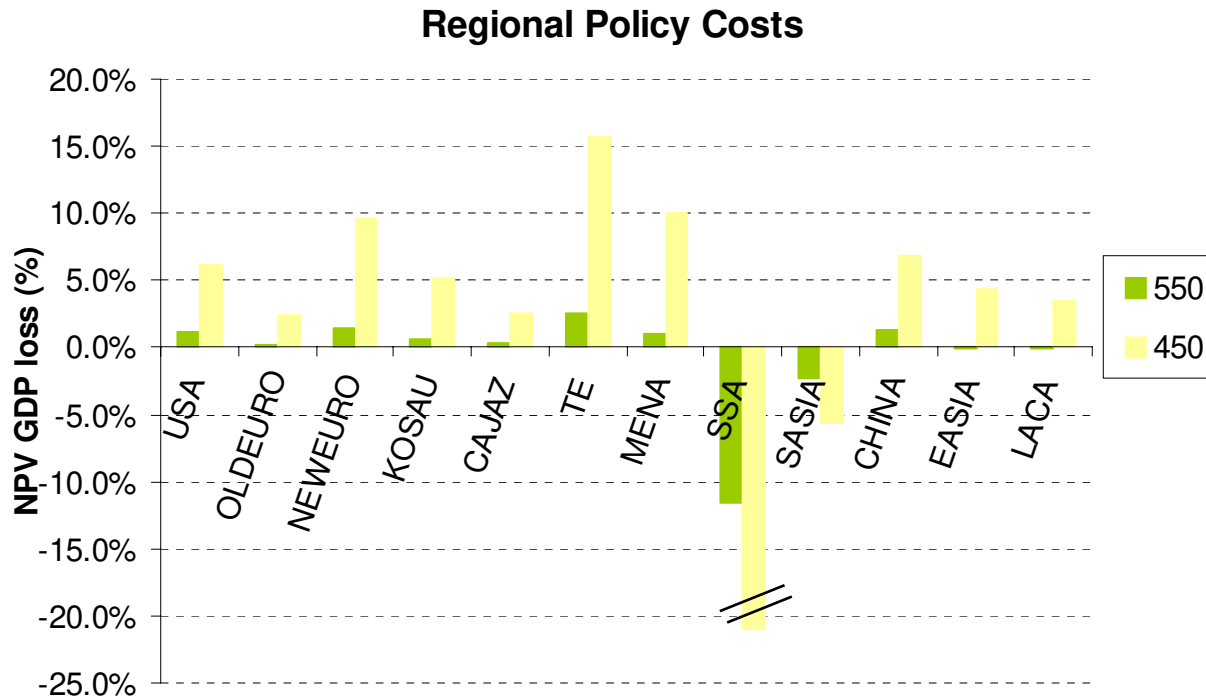



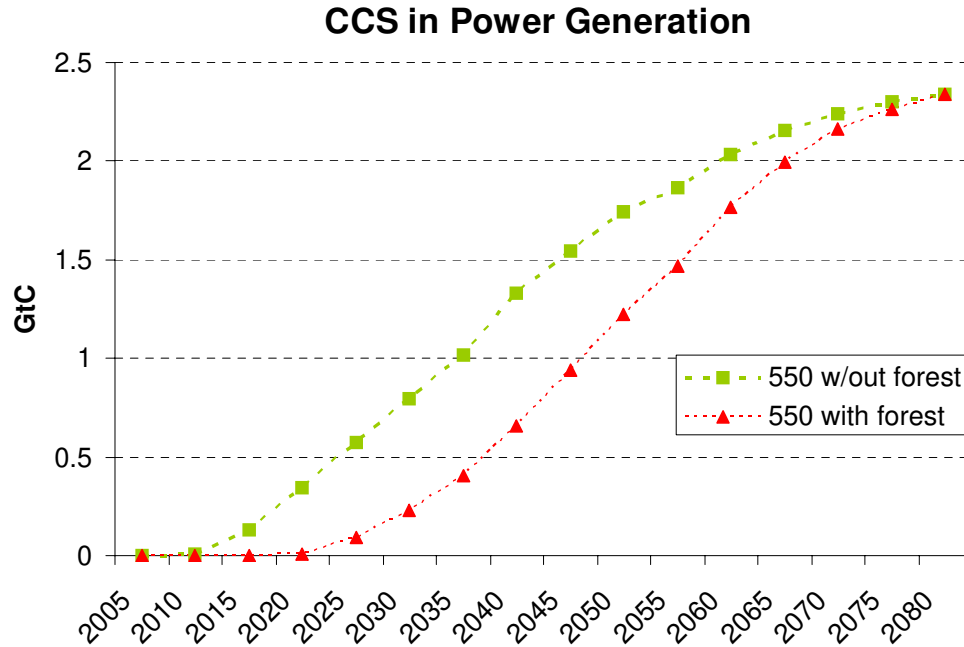

- » halves 550ppmv policy costs
- » achieves 50ppmv extra at no cost
- » delay energy abatement

\* M. Tavoni, B. Songhèn and V. Bosetti (2007) "Forestry and the carbon market response to stabilize climate", FEEM w.p. 15-2007

# Uncertain concentration targets

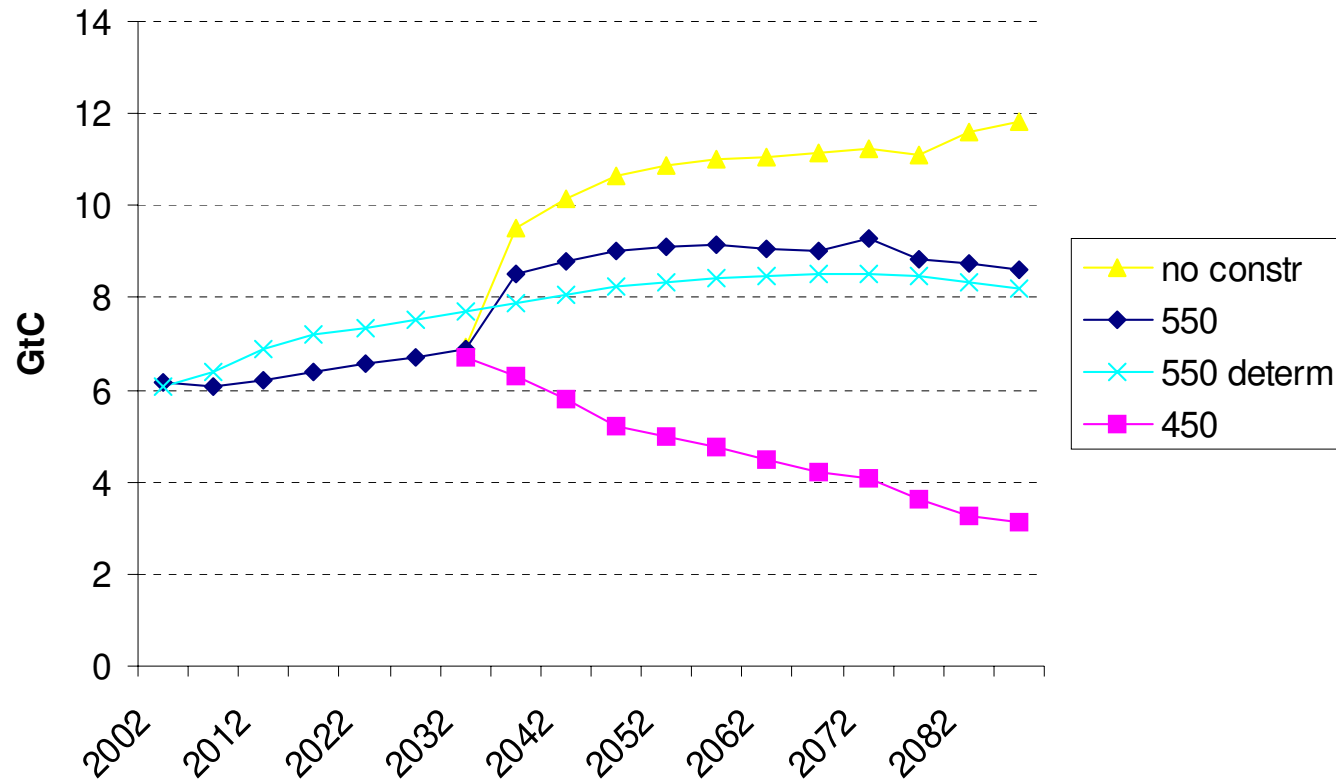

## Optimal abatement (CBA)

- Coop CBA implies lower emissions (600 ppmv at 2100).
- Non-cooperative CBA does not suggest emission levels that scientists might like, mainly because of “global externality” nature of problem.
- Real issue is countries free-riding and how to induce cooperation

## Stabilization Policies (C.E.)

- 550 “cheap” target, 450 tougher (real climate damages, tech. evolution)
- Power sector can do the job but needs Nuclear, CCS and Renewables
- Forestry important mitigation option with a bearing on carbon market/energ abat
- 550 no regret option, 20 yrs on BAU 450 is gone
- Climate uncertainties: more intermediate mitigation/interim conc. targets

[massimo.tavoni@feem.it](mailto:massimo.tavoni@feem.it)

[www.feem-web.it/WITCH](http://www.feem-web.it/WITCH)

## C-E Analysis World GWP loss

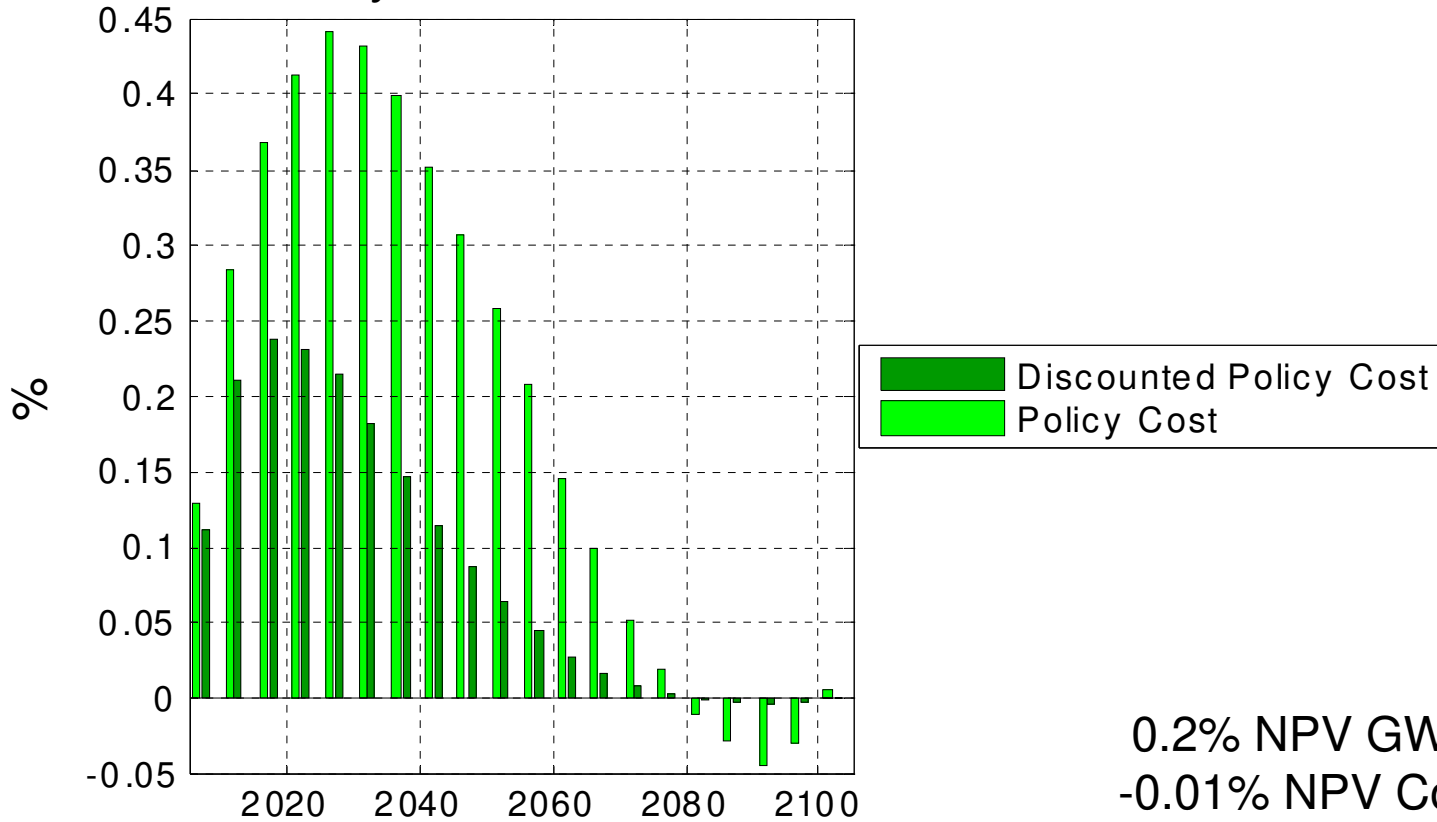

## Distinguishing Features

- Focus on **energy sector**

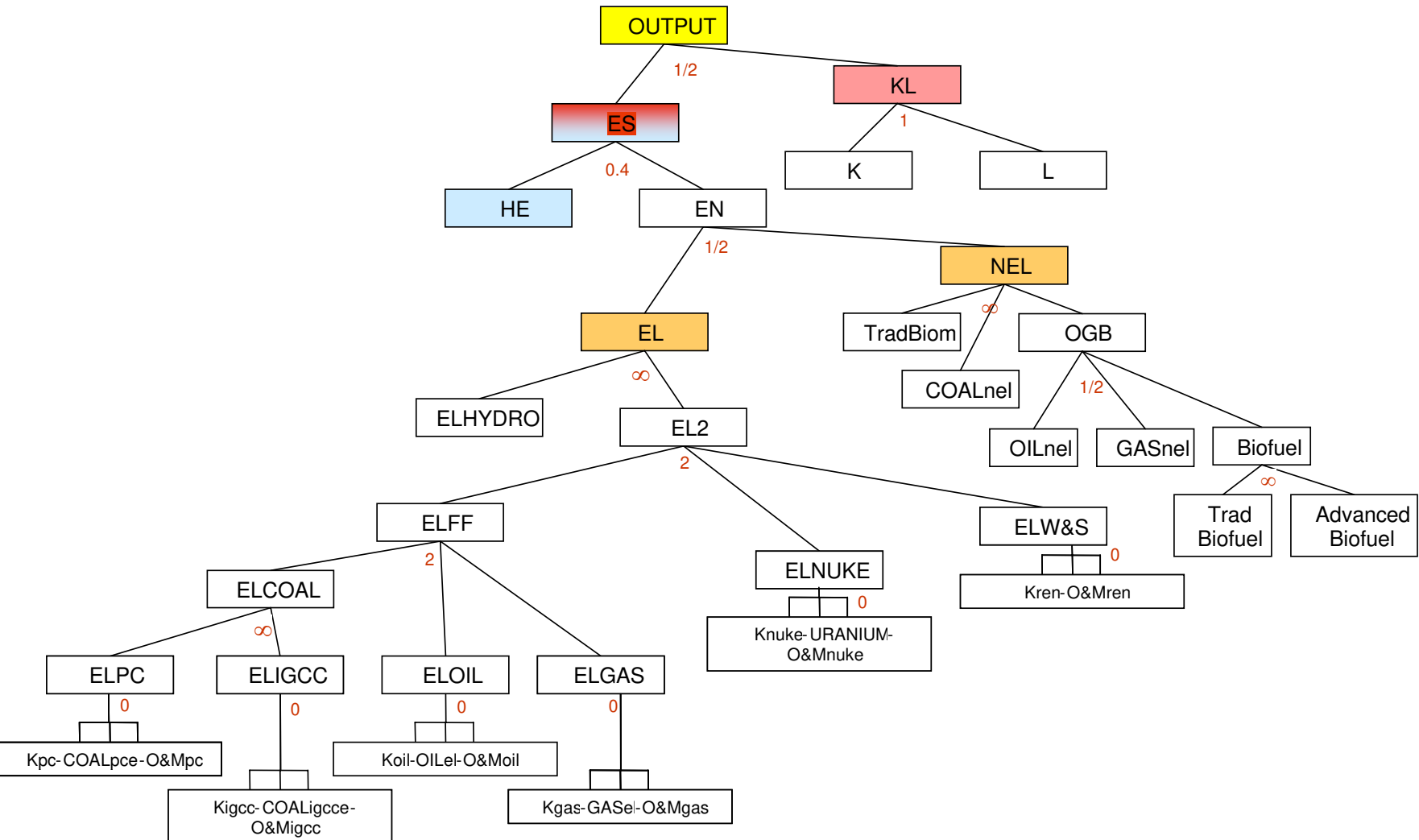

# Algorithm

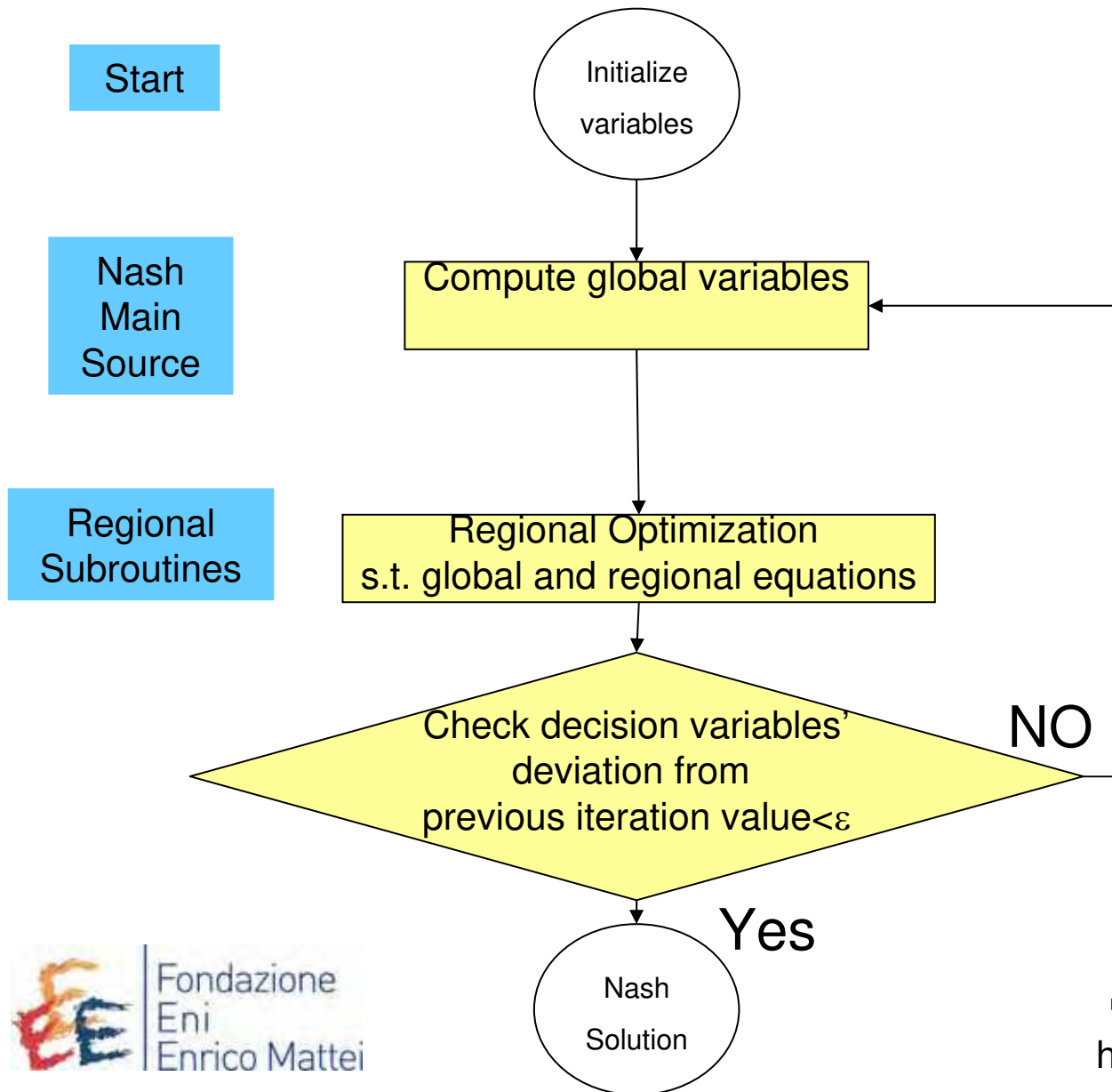

To ease solution searching problem. Each region's problem solved assuming no interactions

To compute Temp, price of resources, W&S capacity installed necessary in each regional optimization problem

$\forall n \in N$



▪The algorithm does not handle global constraints.

Investigating the role of forestry as a stabilization option

**Motivating Issue:**

Missing analysis of carbon market response to forestry mgmt

**General idea:**

Coupling WITCH with a forestry model (Brent Sohngen, Ohio State Univ.)

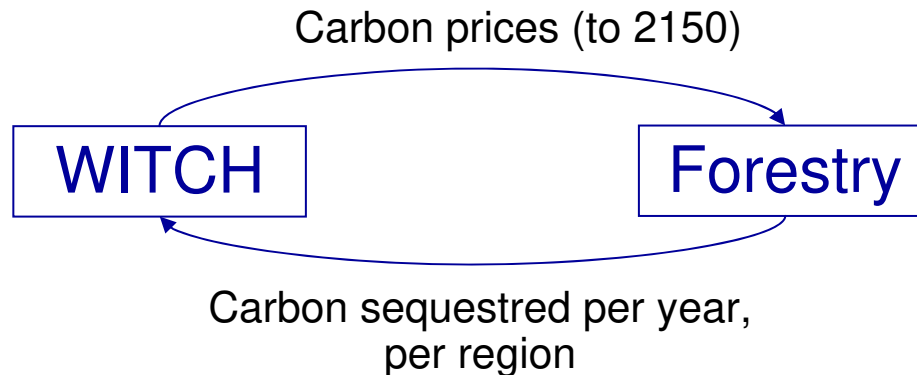



PC

iter 1

**LbD: Investment cost of wind&solar plants wrt to BAU**

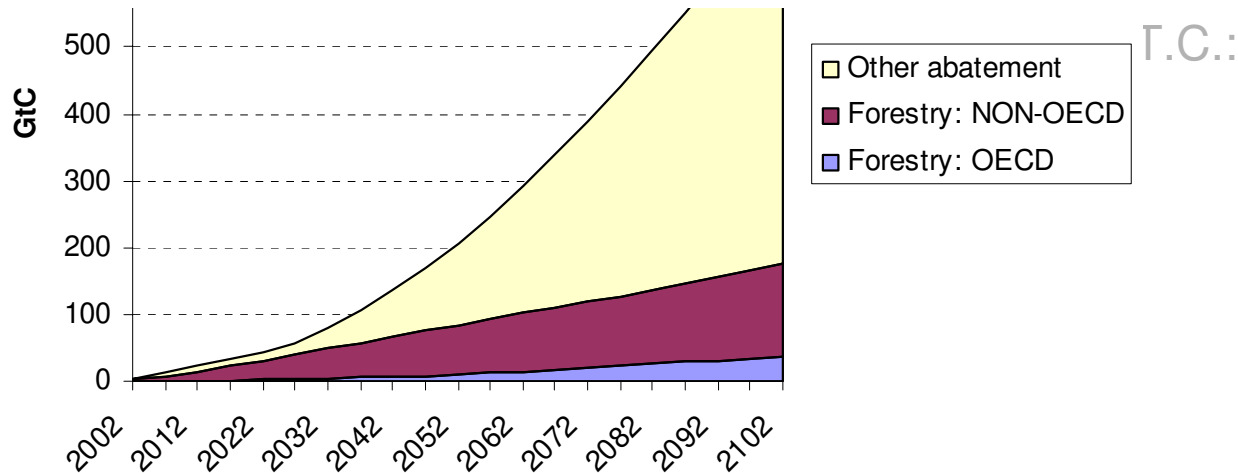
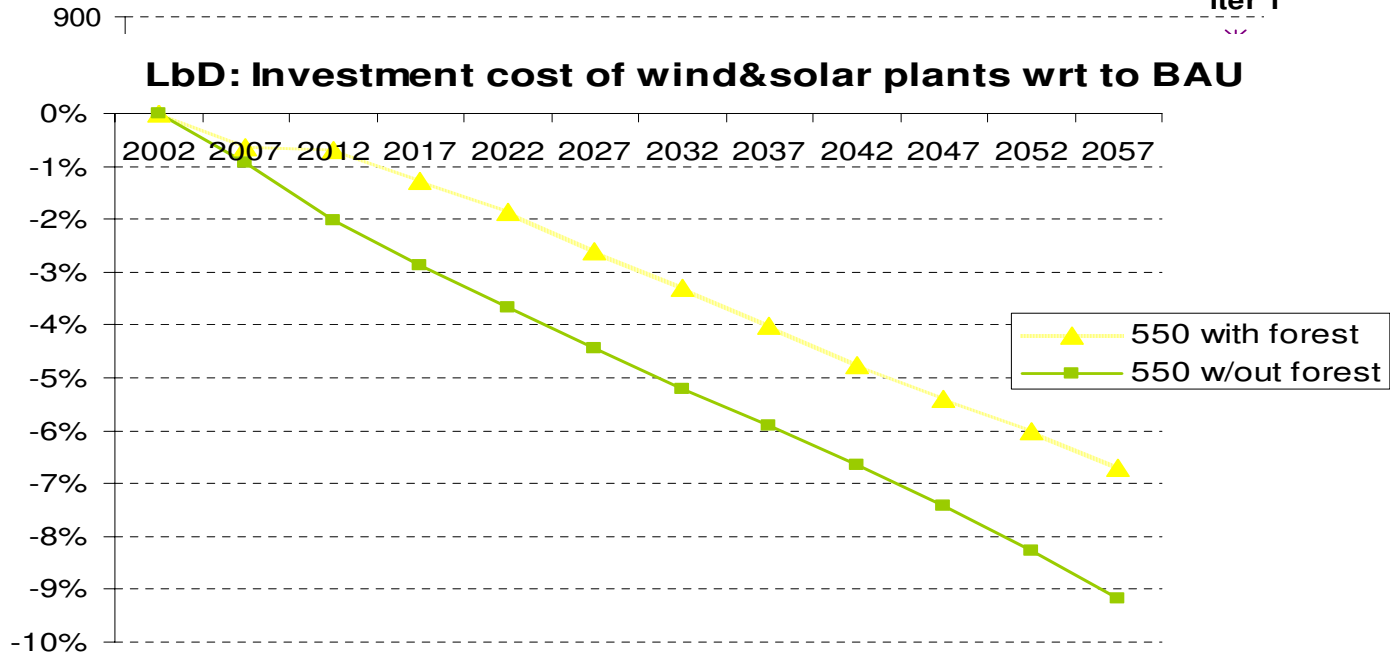

- Cost-Benefit Analysis
- Cost-effectiveness Analysis of climate policies
- Linking Forestry Management to Climate Change Policy
- **Role of Uncertainty in Technological Change Processes**
- Energy Technology Spillovers
- Role of Free Riding
- Role of Discounting

Investigating uncertain effectiveness of innovation in backstop technology

## Motivating Issues:

Literature concentrates on uncertainty of climate damages and costs

1. Some preliminary research on uncertain future arrival of a backstop technology
2. Just few studies (Baker *et al.* 2006) on uncertain effectiveness of R&D

## General idea:

Develop a stochastic version of WITCH and analyze the effect of uncertainty on:

- » optimal levels of investment in R&D fostering the arrival of a carbon-free backstop technology
- » the costs of a stringent climate policy

# Uncertainty Results

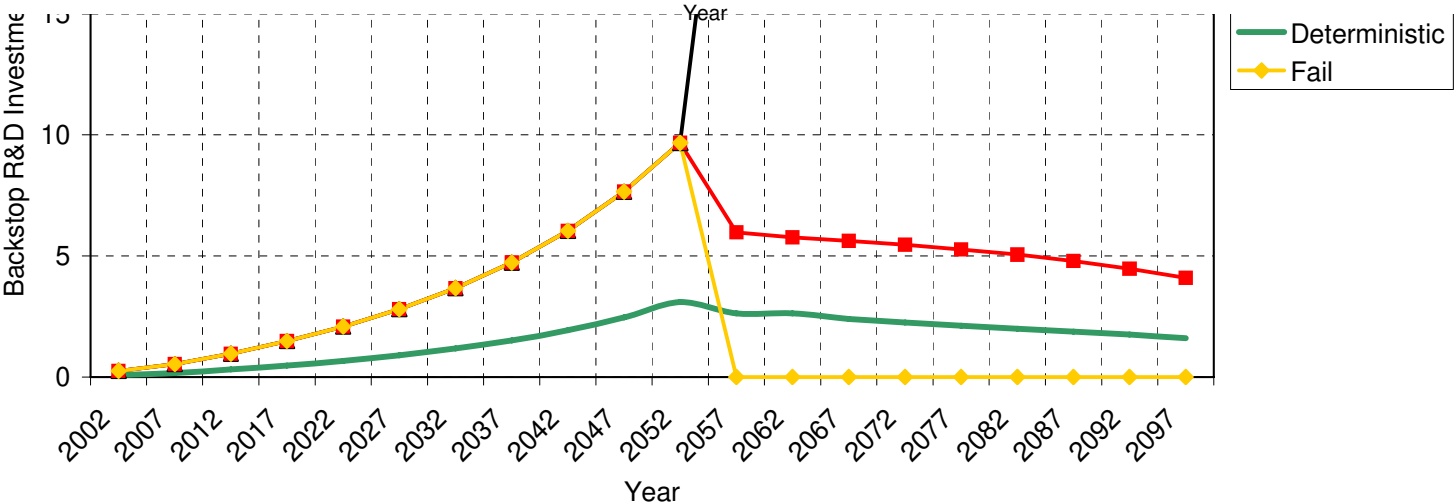
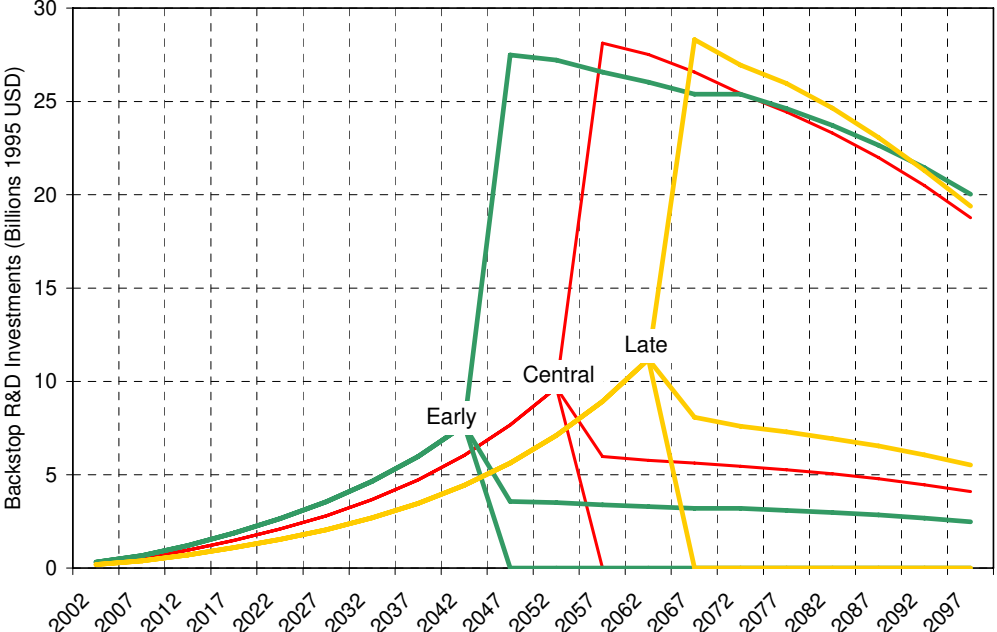

- Interactions between **energy markets** and climate policy
- **Uncertainty** of climate **damages**
- **Spillovers** and **uncertain technological breakthroughs**
- Linking **land use management**-forestry-energy and climate policy
- CDM and **embodied technological spillover**
- Accounting for non-cooperative behaviors in choosing the optimal climate policy instrument under uncertainty
- **Mitigation** vs **Adaptation** strategies

\*Bosetti V., C. Carraro, M. Galeotti, E. Massetti and M. Tavoni, (2006), "WITCH: A World Induced Technical Change Hybrid Model", *The Energy Journal*, Special Issue. Hybrid Modeling of Energy-Environment Policies: Reconciling Bottom-up and Top-down, 13-38.

\*Valentina Bosetti, Carlo Carraro, Emanuele Massetti, Massimo Tavoni (2007) "Optimal Investment Strategies to stabilize GHG Atmospheric Concentrations" FEEM working paper

\*M. Tavoni, B. Songhen and V. Bosetti (2007) "Forestry and the carbon market response to stabilize climate", FEEM working paper

\*V. Bosetti, M. Tavoni (2007) "Uncertain R&D, Backstop Technology and GHG Stabilization", FEEM working paper

[www.feem-web.it/witch](http://www.feem-web.it/witch)

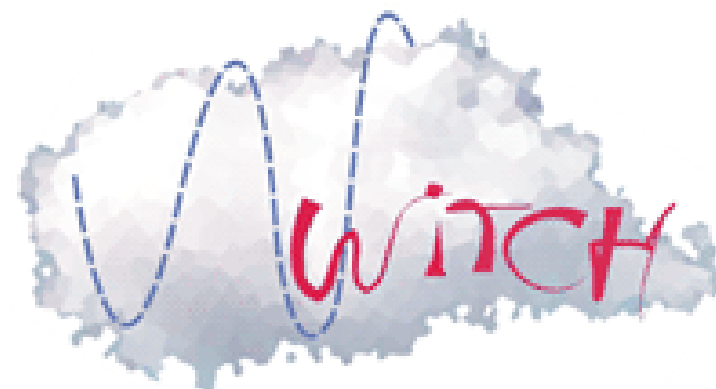

# CO2, energy and income

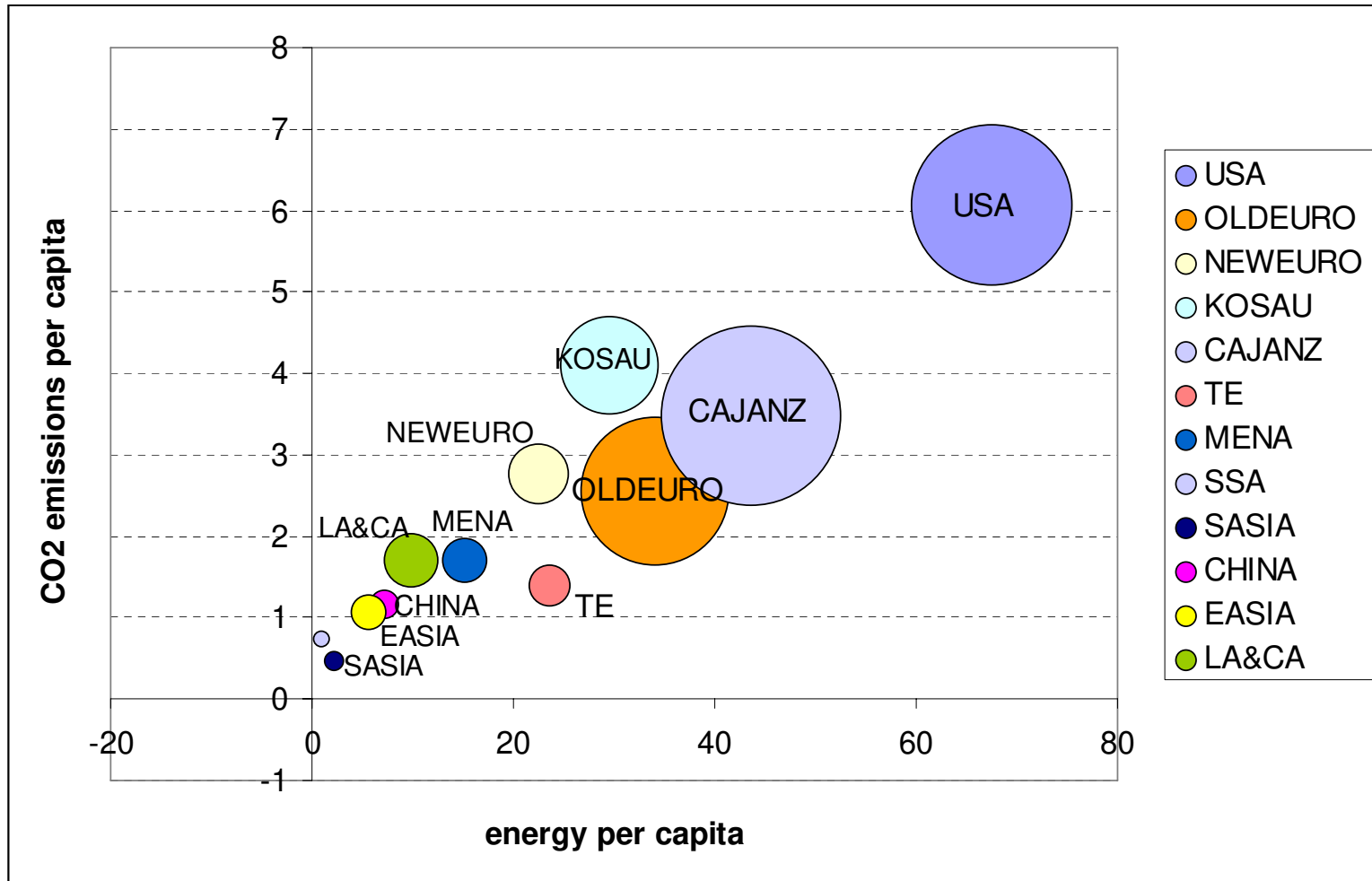

## TOP DOWN

- DICE (Nordhaus) and Entice-BR (Popp) no energy detail nor regional disaggregation.
- DEMETER (Gerlagh), no regional disaggregation nor strategic choice of optimal investment profiles.

## BOTTOM UP

- Energy system models (e.g., Markal, Message), no forward looking nor accounting for strategic behavior and related inefficiencies.

## HYBRID MODELS SOFT LINKED

- MERGE (Richels et al.) stand-alone optimization nor accounting for strategic behavior and related inefficiencies.

## HYBRID MODELS HARD LINKED

- MIND (Edenhofer et al.) no regional disaggregation nor strategic choice of optimal investment profiles. Single fuel.
- **WITCH** (World Induced Technical Change Hybrid model)



# The Objective Function

For each region ( $n$ ) forward-looking central planner maximizes present value of ( $\log$ ) per capita consumption (5-yr time steps):

$$(1) \quad W(n) = \sum_t L(n,t) \{ \log [ c(n,t) ] \} R(t)$$

choosing the optimal path of investment variables simultaneously and strategically with respect to the other decision makers.

Consumption of the single final good obeys to the economy budget constraint:

$$(2) \quad C(n,t) = Y(n,t) - I_C(n,t) - \sum_j I_{R\&D,j}(n,t) - \sum_j I_j(n,t) - \sum_j O\&M_j(n,t) \\ - \sum_f P_f(n,t) X_f(n,t) - P_{CCS}(n,t) CCS(n,t)$$

Final Good
Energy R&Ds
Electricity Generation
Operation & Maintenance

Net fuel expenditures
CCS (Transport and storage costs)

# Output and Climate Damage

Gross output produced via capital, labour (=population) and energy services.

$$(3) \quad Y(n,t) = \frac{TFP(n,t) \left[ \alpha(n) \cdot \left( K_C^{1-\beta(n)}(n,t) L^{\beta(n)}(n,t) \right)^\rho + (1-\alpha(n)) \cdot ES(n,t)^\rho \right]^{1/\rho}}{\Omega(n,t)}$$

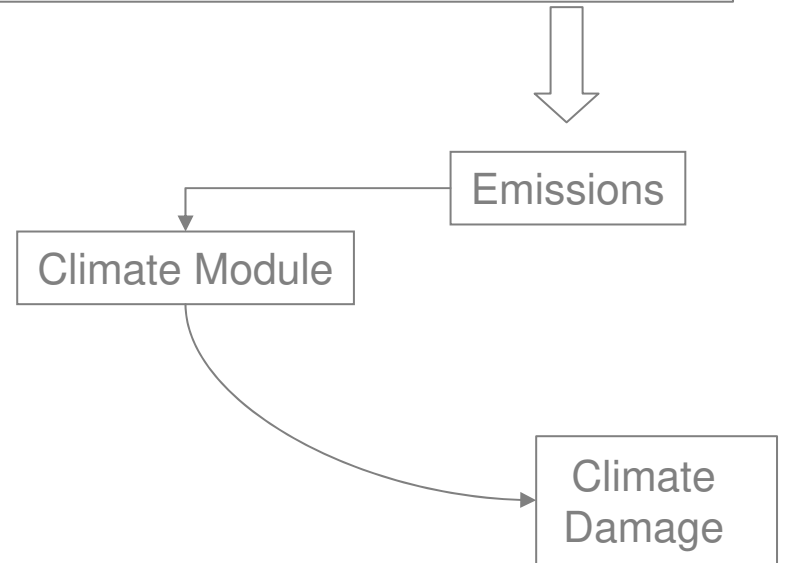

# The Energy Sector

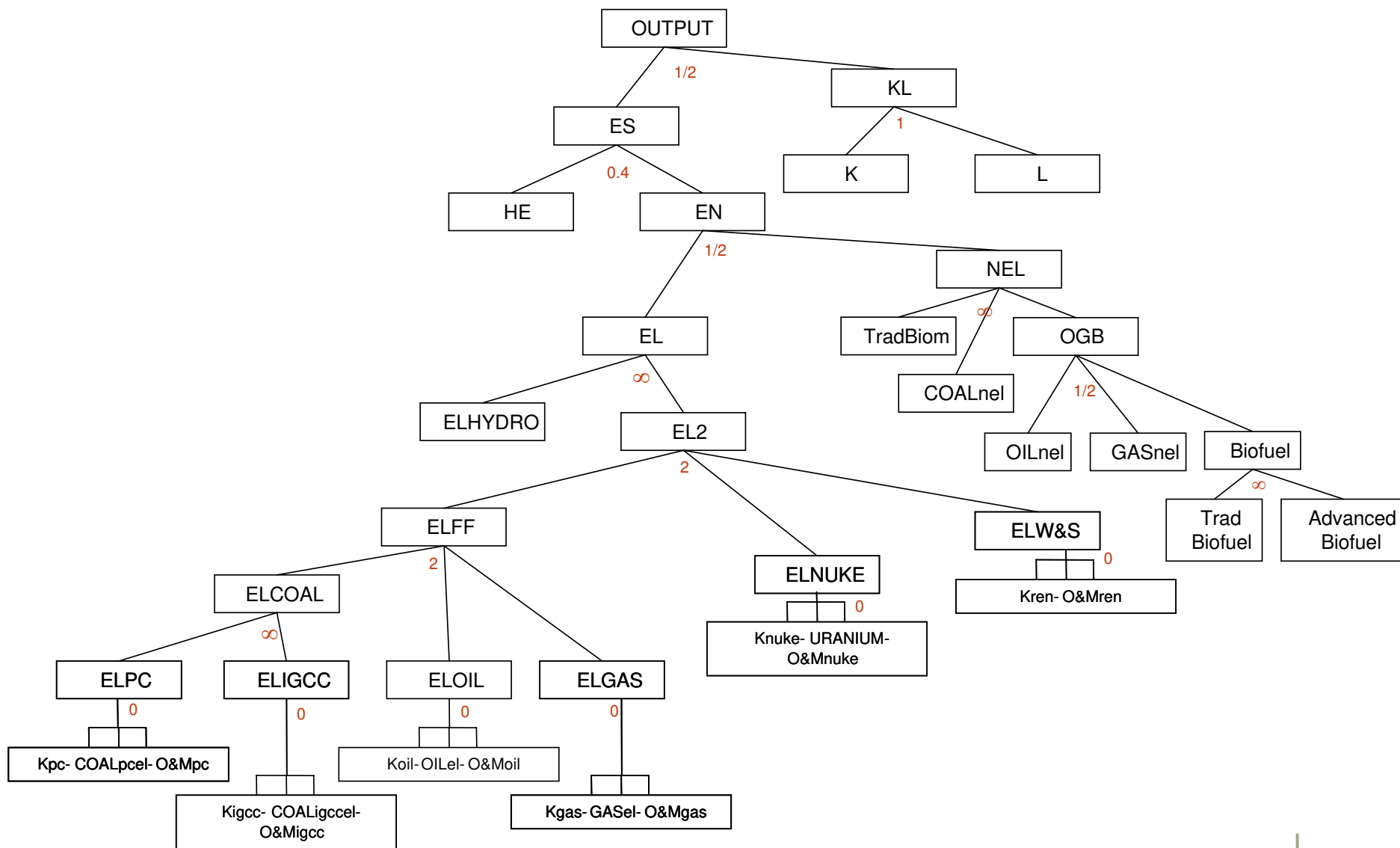

ETC is represented through both *accumulation of experience* and *R&D investment*:

i. **Learning by Doing** via experience curves in power plants investment cost

$$(4) \quad SC_j(n, t) = B_j \sum_n K_j(n, t-1)^{-\log_2 PR_j} + \xi_n$$

world learning, assume technology spillover

ii. **Energy R&D** for increasing **energy efficiency** (Popp)

$$(5) \quad ES(n, t) = \left[ \alpha_H HE(n, t)^\rho + \alpha_{EN} EN(n, t)^\rho \right]^{1/\rho}$$

$$(6) \quad HE(n, t+1) = a I_{R\&D}(n, t)^b HE(n, t)^c + HE(n, t)(1 - \delta_{R\&D})$$



# PROMOTION STRATEGIES FOR ELECTRICITY FROM RENEWABLES IN THE EU – LESSONS LEARNED

**Reinhard Haas**

Energy Economics Group,  
Vienna University of Technology

**ROSKILDE, 22nd May 2007**

## 1. Introduction

## 2. Additional costs for final customers

## 3. A comparison of the success

## 4. Achievements and prospects

## 5. The issue of competition

## 6. Conclusions

**Thanks to the EC (DG RESEARCH,  
DG TREN)**

## CORE MOTIVATION:

**Policy targets for an  
INCREASE of RES-E!**

**(e.g. currently discussed targets of  
20% for 2020)**

## SURVEY ON INSTRUMENTS TO PROMOTE ELECTRICITY FROM RENEWABLES

		REGULATORY	VOLUNTARY
Capacity-driven strategies	Generation-based	<ul style="list-style-type: none"> <li>• RPS</li> <li>• Quota-based TGCs</li> </ul>	<ul style="list-style-type: none"> <li>• National generation targets</li> </ul>
	Investment focused	<ul style="list-style-type: none"> <li>• Bidding/Tendering</li> </ul>	<ul style="list-style-type: none"> <li>• National installation or capacity targets</li> </ul>
Price-driven strategies	Generation-based	<ul style="list-style-type: none"> <li>• feed-in tariffs,</li> <li>• Rate based incentives</li> <li>• Net metering</li> </ul>	<ul style="list-style-type: none"> <li>• Green Power Marketing               <ul style="list-style-type: none"> <li>• Green tariffs</li> </ul> </li> <li>• Solar stock exchange</li> </ul>
	Investment focused	<ul style="list-style-type: none"> <li>• Rebates</li> <li>• Soft loans</li> <li>• Tax incentives</li> </ul>	<ul style="list-style-type: none"> <li>• Contracting</li> <li>• Shareholder progr.</li> <li>• Contribution               <ul style="list-style-type: none"> <li>• Bidding</li> </ul> </li> </ul>
Other		-	<ul style="list-style-type: none"> <li>• NGO-marketing</li> <li>• Selling green buildings               <ul style="list-style-type: none"> <li>• Retailer progr.</li> <li>• Financing</li> </ul> </li> <li>• Public building prog.</li> </ul>



# What is the problem?

## *Which instrument fits best?*

Should an **ambitious RES-E target** be met in the short and long-term?

Should it reflect the external costs?

Should RES-E technologies be promoted on broad scale?

Should it be compatible with the conventional electricity market?

*Answer depends on POLICY OBJECTIVE*

Should the system be implemented on a national or international level?

Is international burden sharing for consumer an important goal?

How should the premium costs / burden for consumer be distributed over time?

## MAJOR PROBLEM:

**Correct design of  
policy**

- **with respect to:**
  - **renewable targets**
  - **Financial incentives**
  - **Credibility for investors**
- **Consideration of external costs?**

# 2 THE ISSUE OF TRANSFER COSTS

***All regulatory promotion schemes  
(Quota-based TGC systems, tendering  
systems, Feed-in tariffs) create an  
artificial market***

***and cause***

***transfer costs (additional costs)***

---

*It is important to minimize  
these additional transfer costs.*

*Why?*

*These additional costs have finally to be  
paid by the electricity customers*

**(regardless which promotion scheme is  
chosen)**

## STATIC COST RESOURCE CURVES

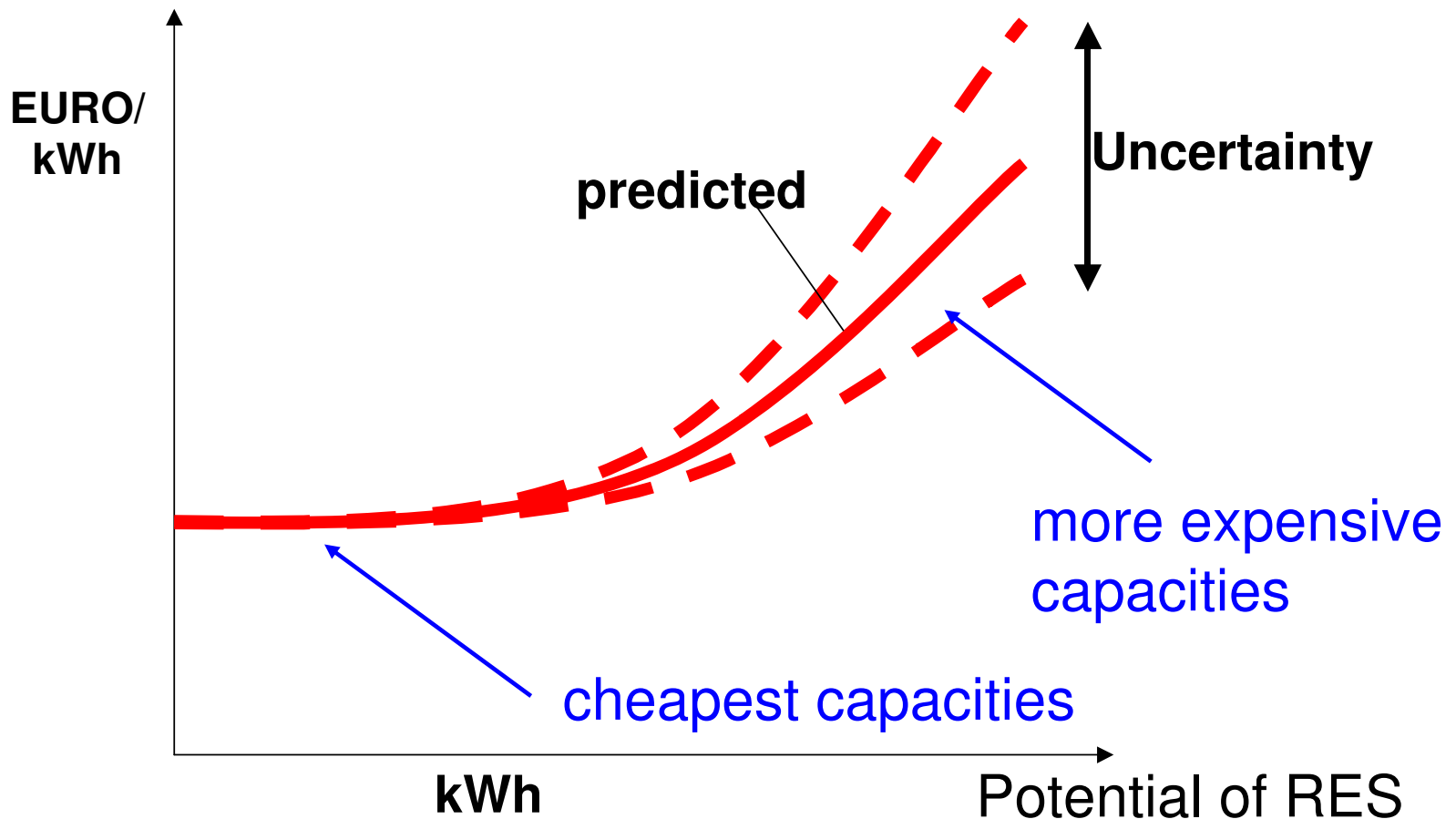

# Method of approach (EU-project GREEN-X)

Minimise additional costs for consumers = **Producer Surplus** + Generation costs - Revenues electricity market

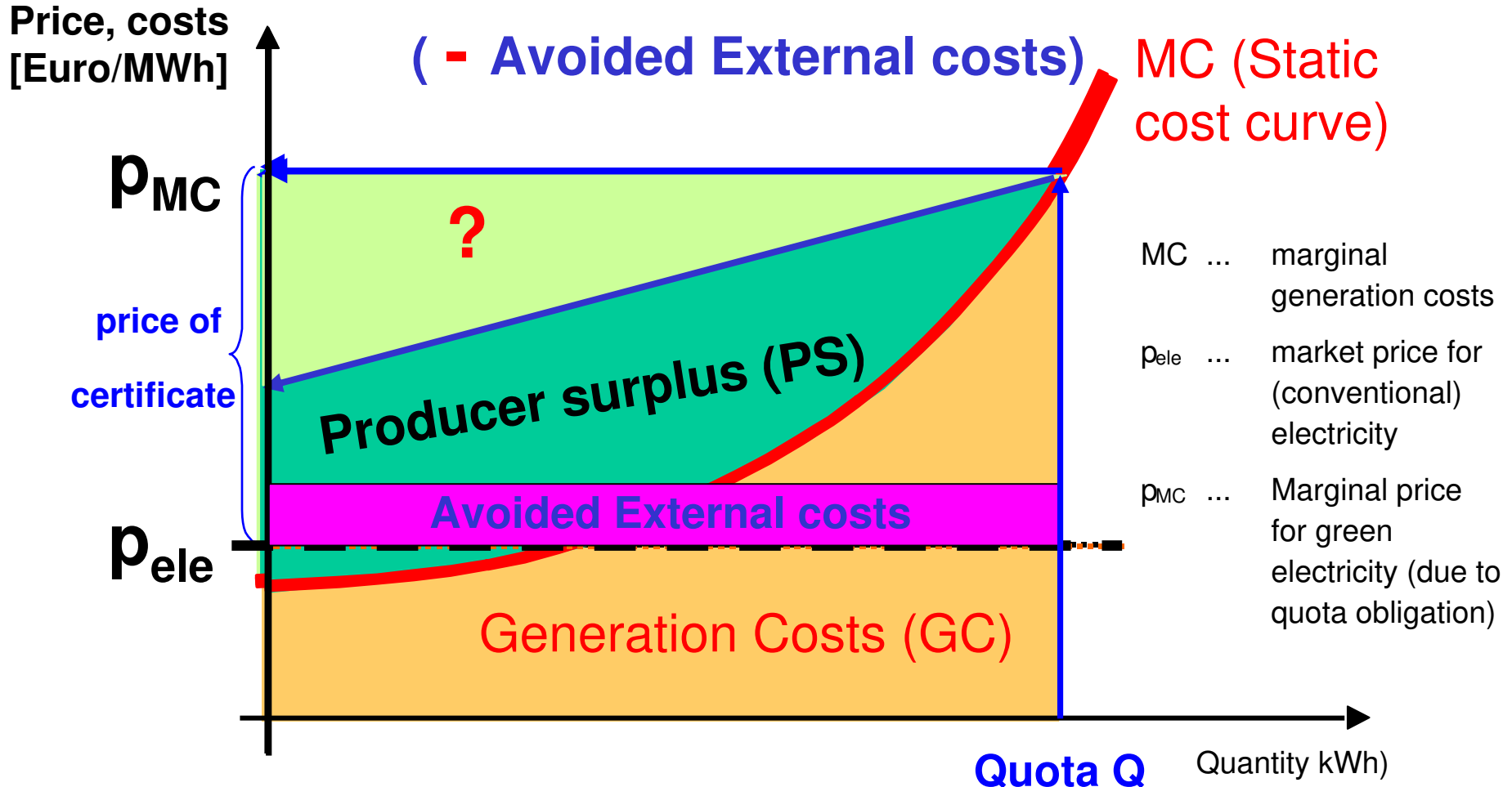

# Transfer costs vs avoided costs

## *Example: Promotion of wind in Germany 2005*

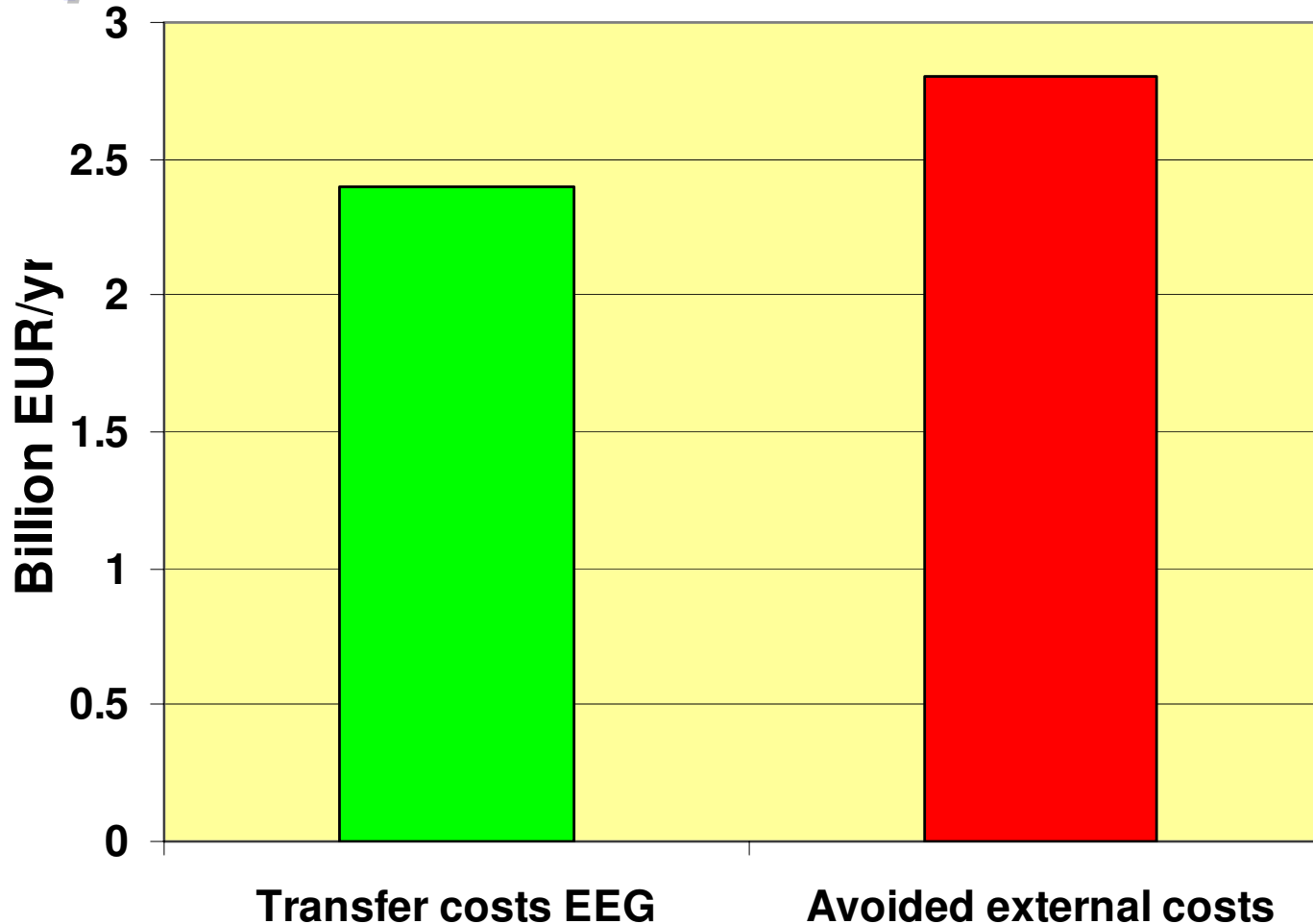

*Source: Krewitt/Schlomann: Externe Kosten ... (2006)*

***The lower the additional costs  
(=transfer costs) are which have  
finally to be paid by electricity  
customers***

***the higher will be public acceptance***

***the larger will be the amount of  
additional electricity generated from  
RES.***



***An example from the conventional electricity market:***

***in several countries (e.g. Germany, Belgium) customers are fed up with the high profits the large incumbent utilities make in the “free” market***

***they request a re-regulation of electricity prices!***

## TO SUCCESSFUL STRATEGIES

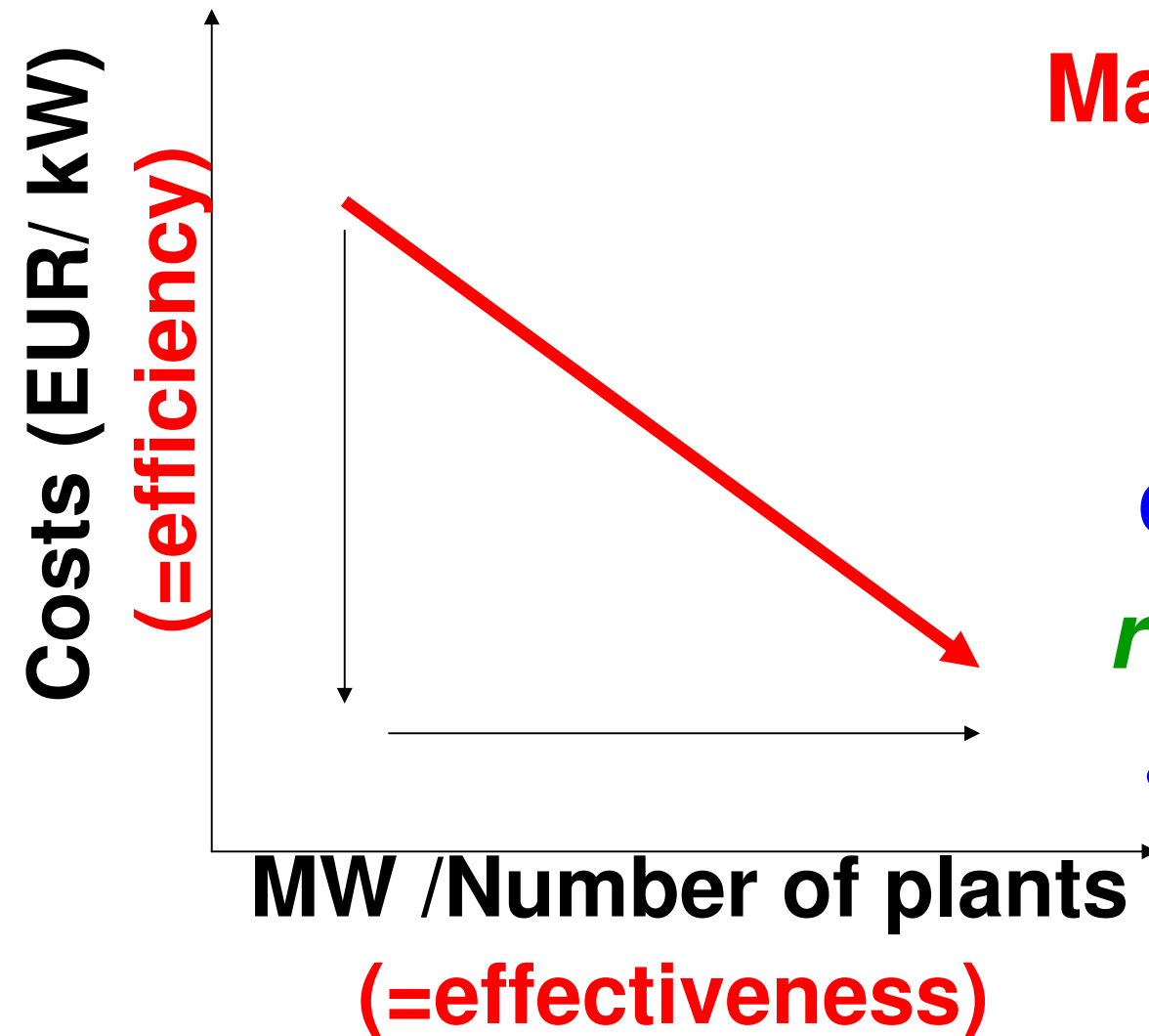

Major objectives:

- increase the amount of electricity from *renewables* and
- reduce costs!

# EFFECTIVENESS VS COSTS

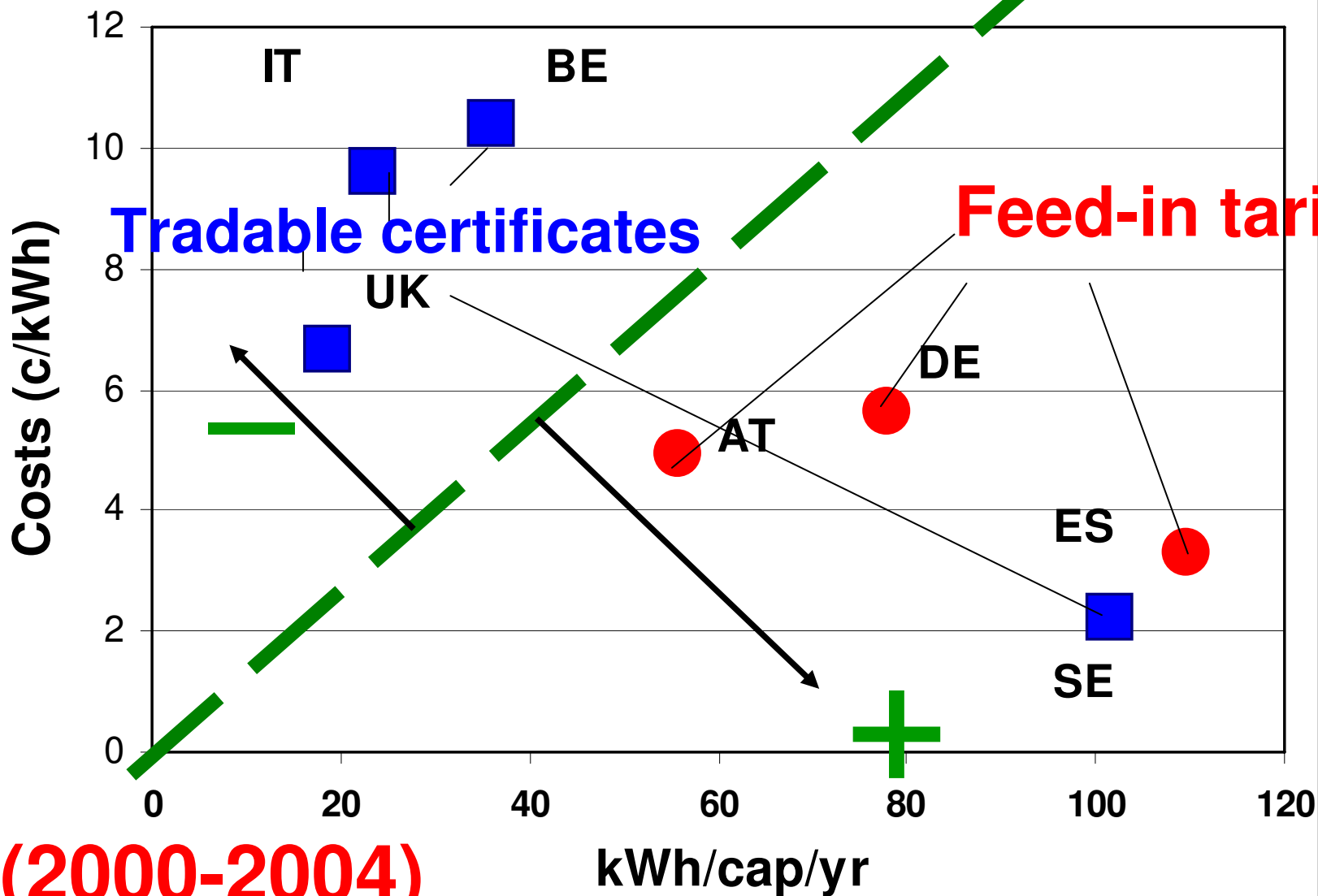

(2000-2004)

# SUCCESS CRITERIA FOR FIT's

1 Use a stepped FIT and calculate starting values carefully

2 Identify ecological bonus

3 Decrease over time, link to

conv. electr.

market prices

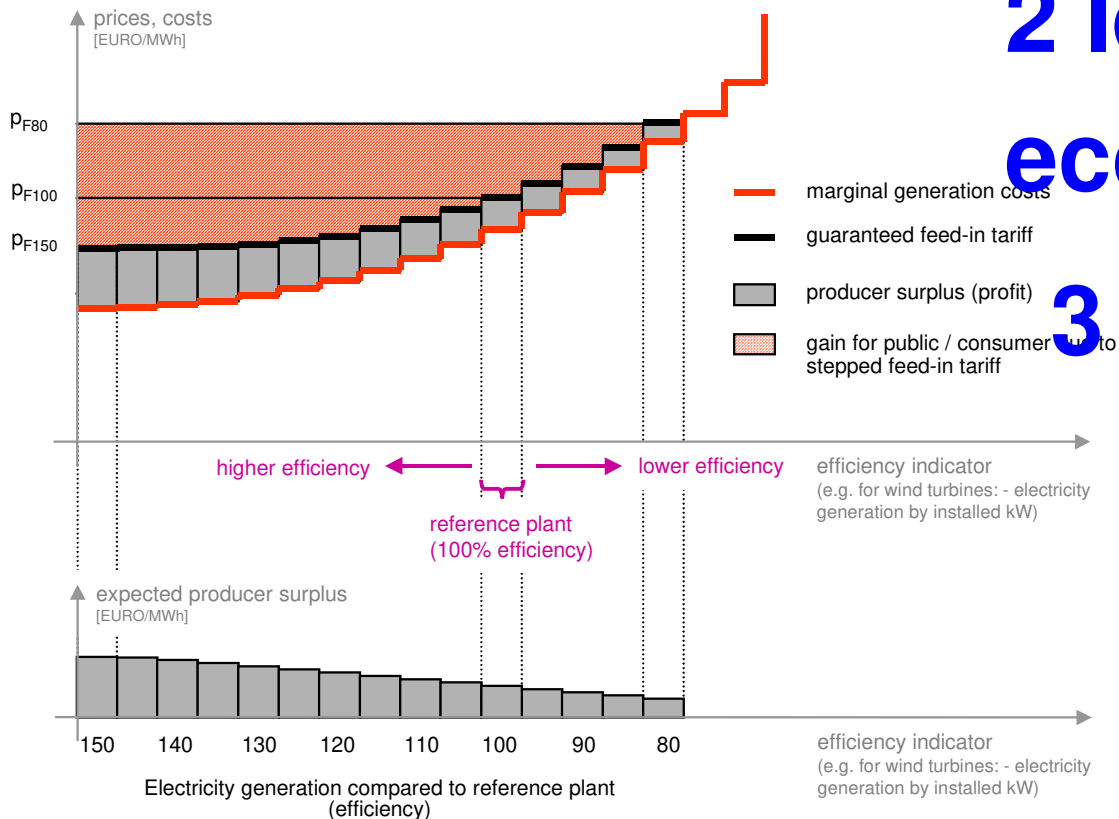

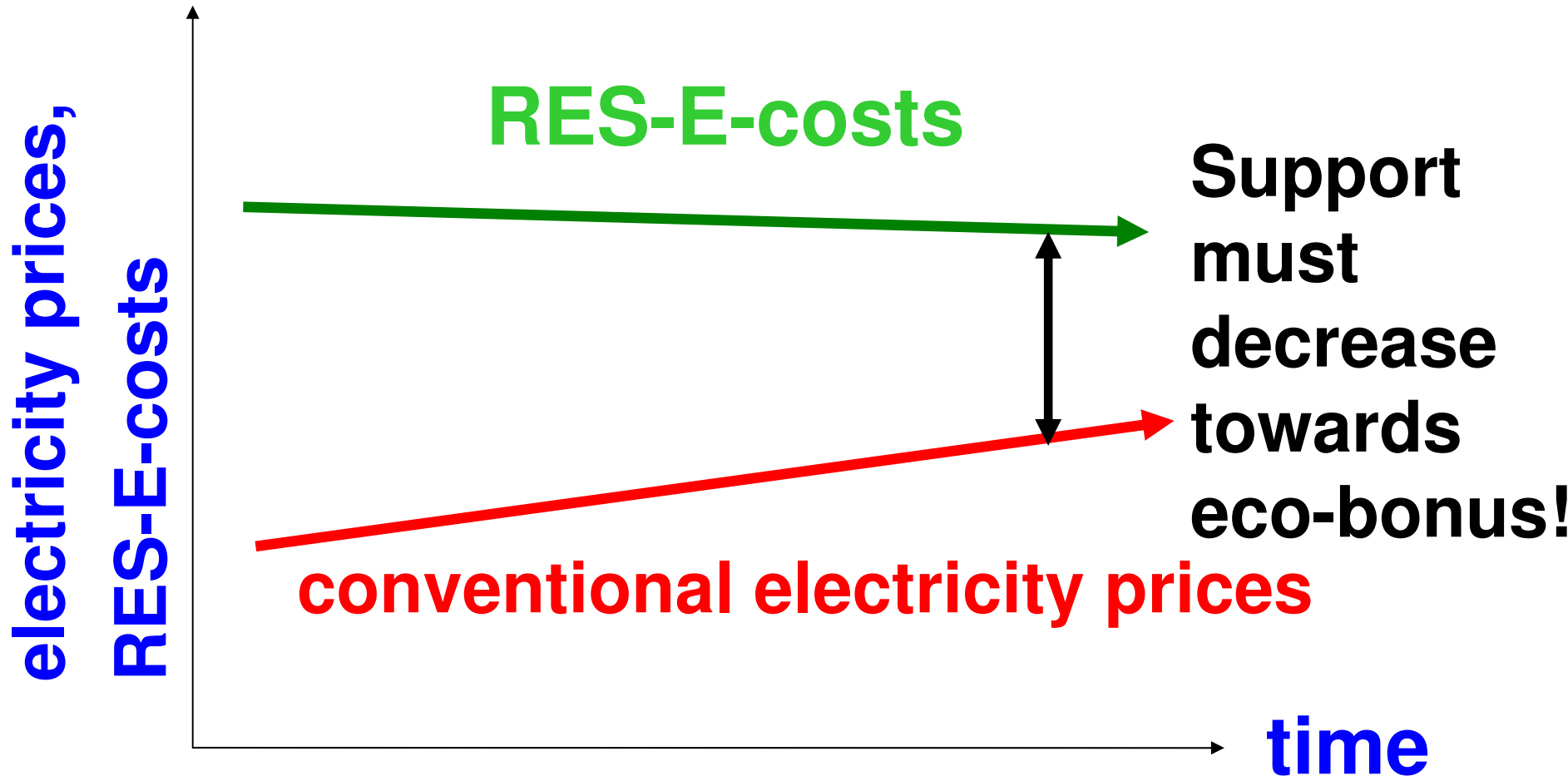

- For FIT/premium: Consider „learning“ by a dynamic component!

# FOR QUOTA-BASED TGC'S

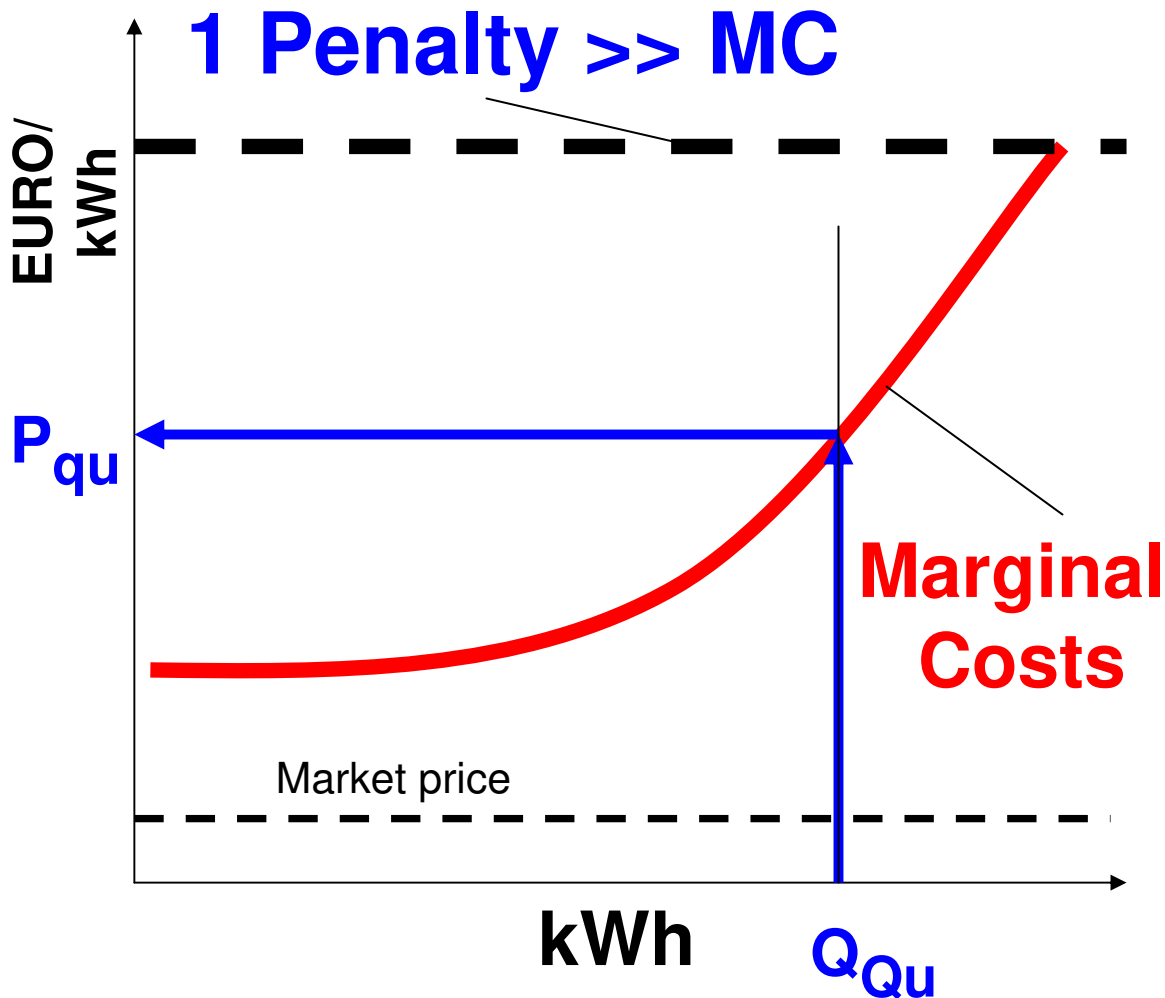

2 Ensure long-term planning horizon!

3 Focus on new plants

4 Allow banking

# MAJOR PITFALLS FOR QUOTA-BASED TGC's

- 1 Market too small: e.g. in a small country for one technology with very limited potential -> Non-Liquid because every single plant is known (e.g. Flanders (BE))**
- 2 Penalty is too low (e.g. UK)**
- 3 Short planning horizon (e.g. UK 2003, Italy)**
- 4 The problem of windfall profits for (existing) capacities (e.g. Flanders (BE), Sweden)**

---

# 4. WHAT HAS BEEN ACHIEVED SO FAR AND WHAT CAN BE EXPECTED FOR THE FUTURE?



# TOTAL ELECTRICITY GENERATION FROM

## RENEWABLES IN EUROPE

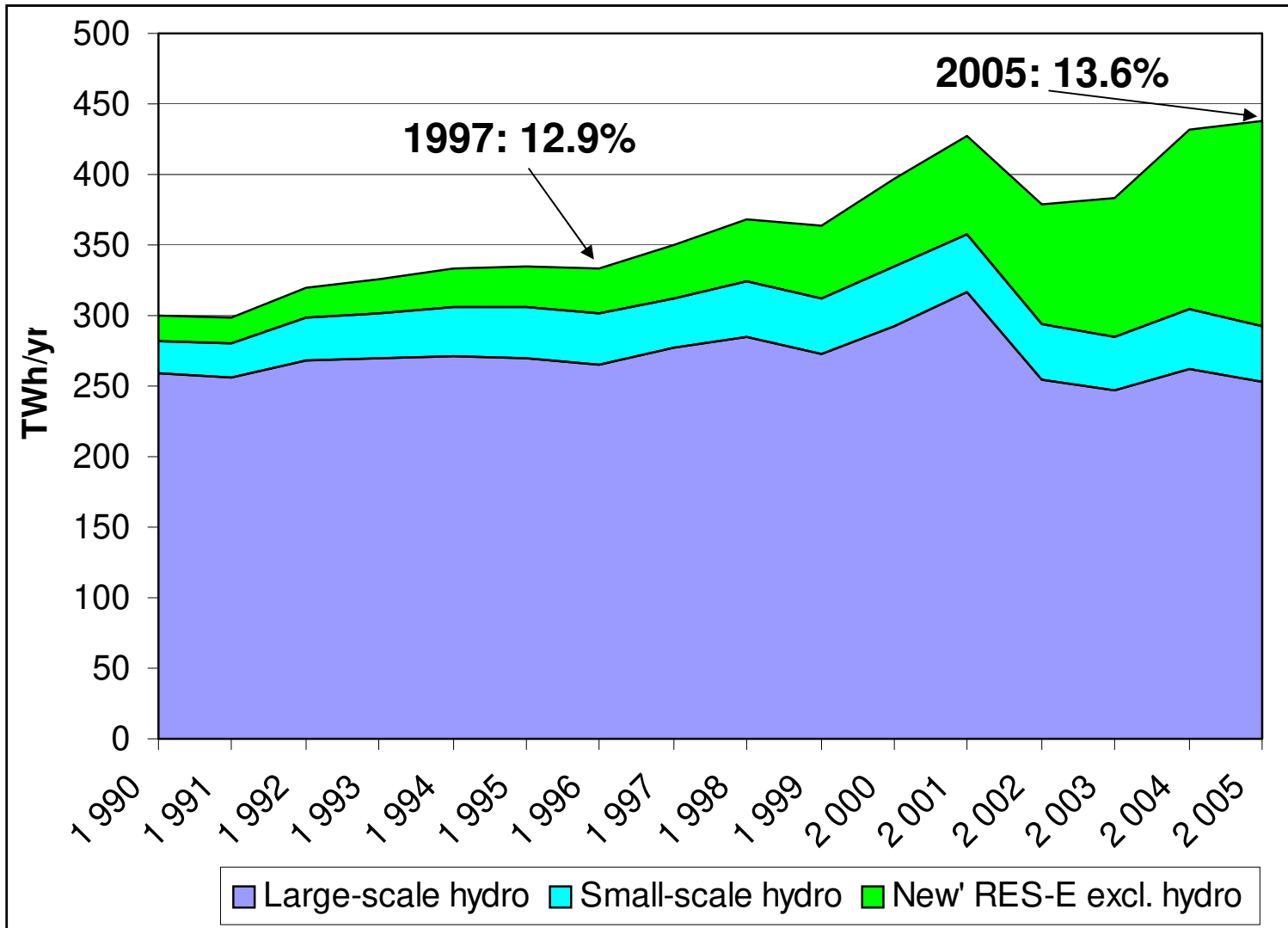

# ELECTRICITY GENERATION FROM „NEW“ RENEWABLES IN EUROPE

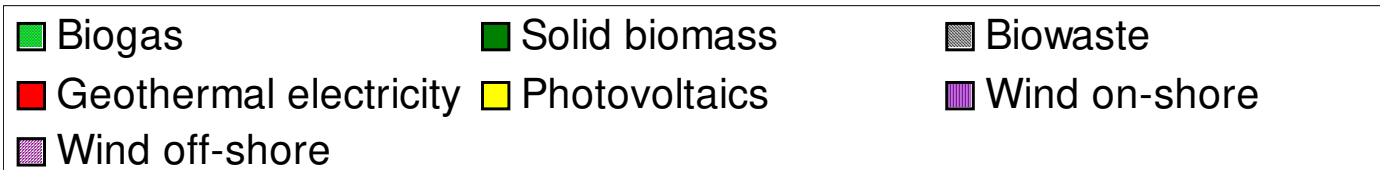
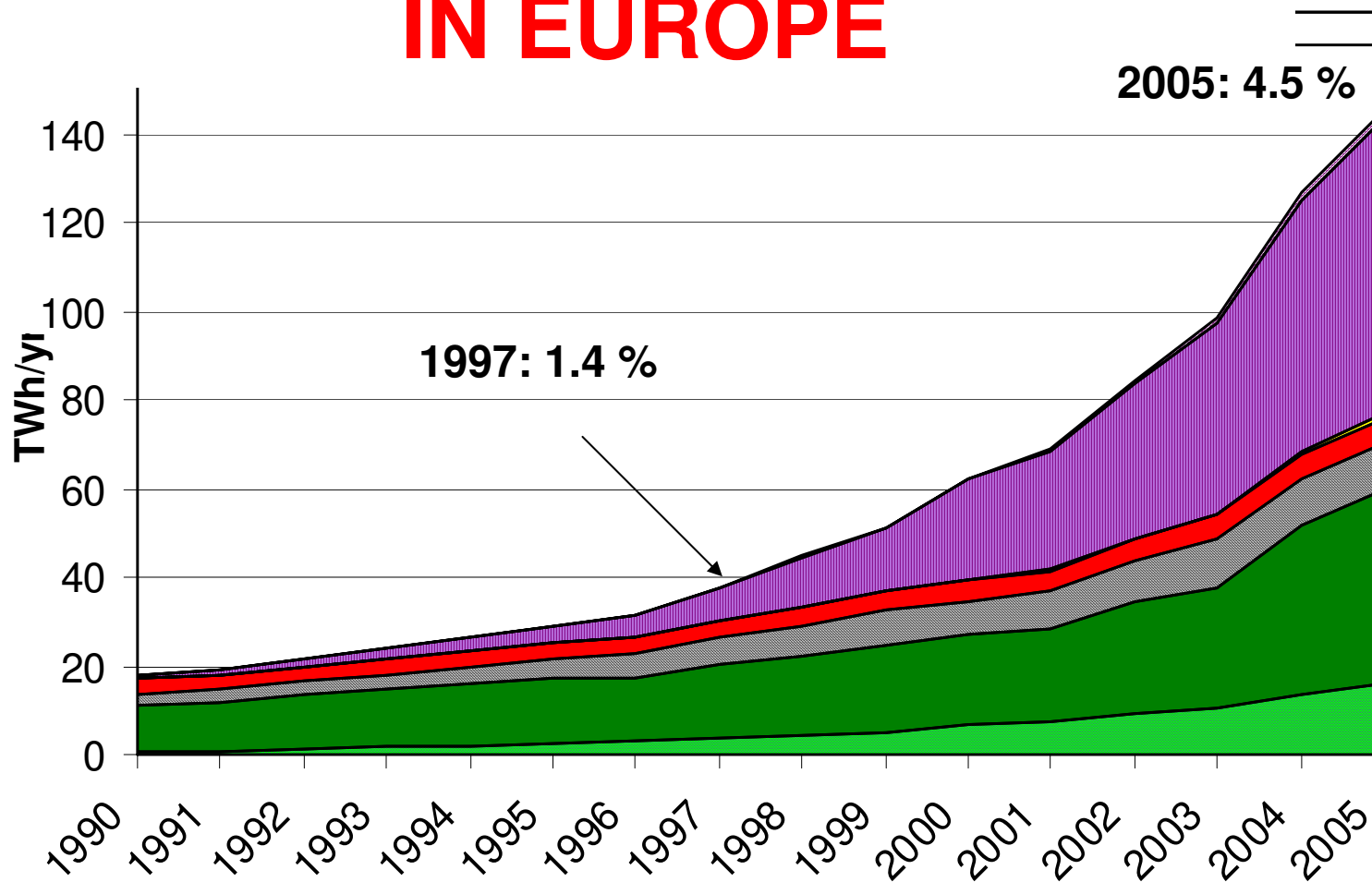

# SOME RESULTS OF GREEN-X: CASE STUDY 2020

Total current electricity consumption: 3200 TWh

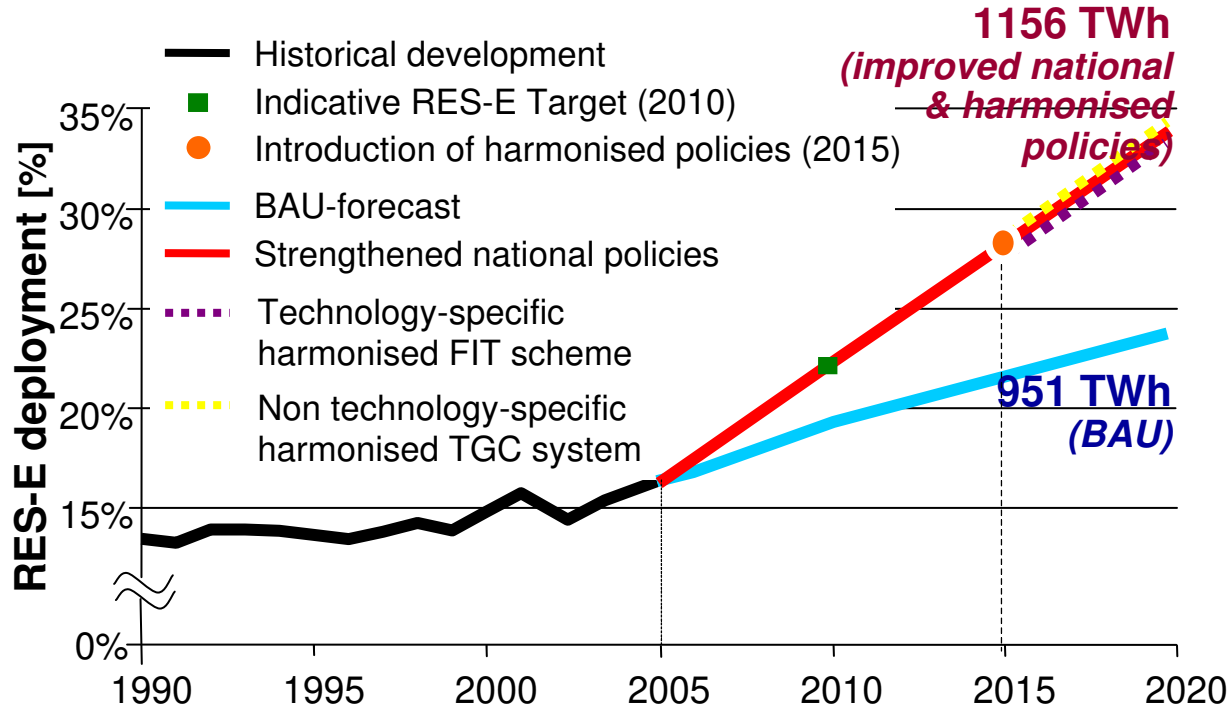

Investigated cases:

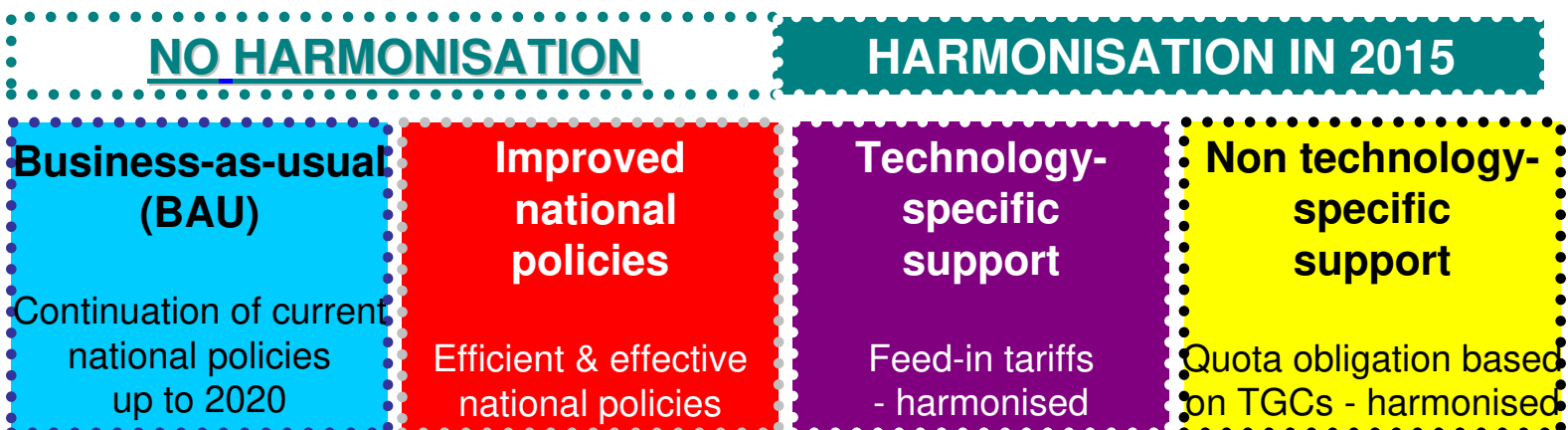

# Total electricity generation from RES (EU25) as share of gross electricity demand

**BAU scenario**

*...how far will we come with current RES policies?*

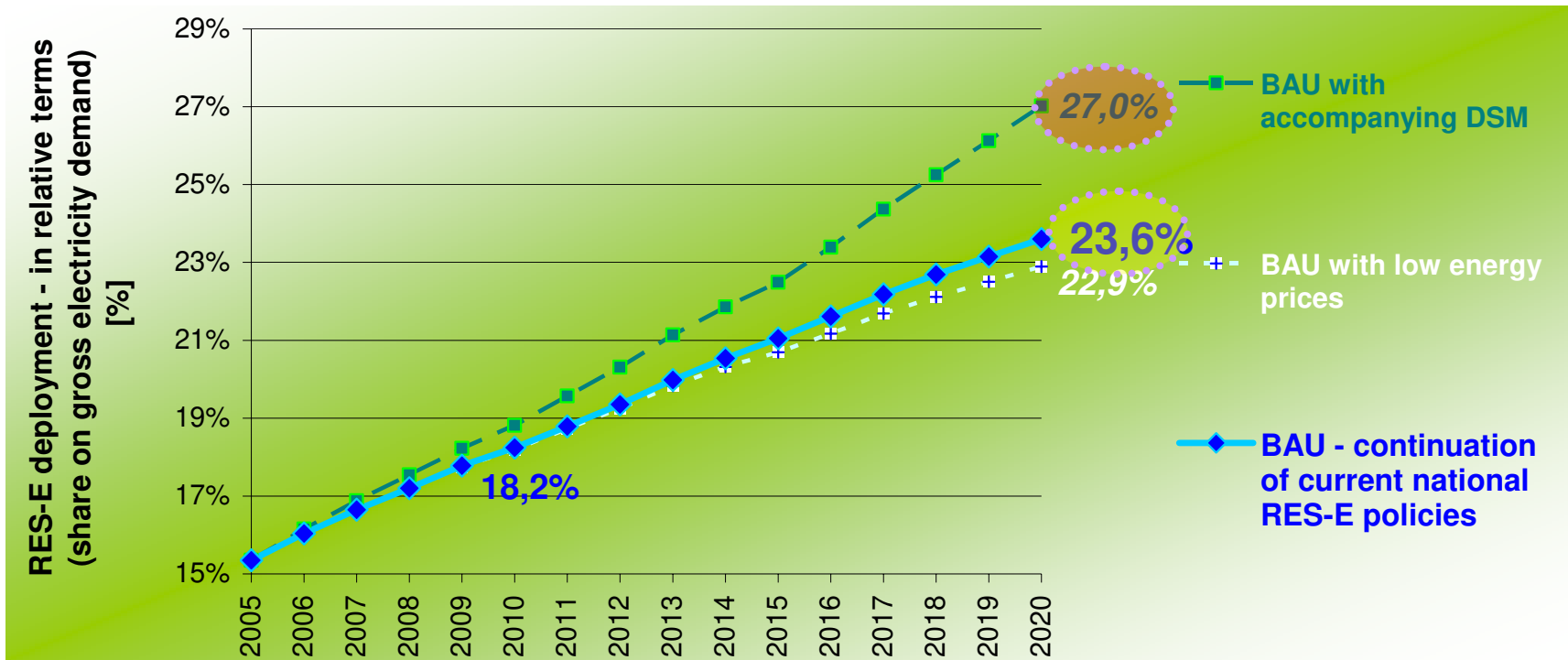

*...the impact of an active DSM policy and conventional energy prices*

## 5. COMPETITION ?

- conventional electricity **market**: To maximize profits utilities merge to avoid **competition**
- hard to imagine that a European-wide TGC market will work disconnected from these large incumbents
- TGC markets: Why should competition work if it does not in the conventional electricity market?
- Utilities/generators are in favour of TGC because they can make much more money and control the market, the construction of new plants much better

- 
- We are far away from an optimal solution but we are on the way!
  - **Careful design of strategies:**  
**by far the most important success criteria!**
  - There should be a clear focus on **NEW capacities!**
  - **To ensure significant RES-E deployment in the long-term, it is essential to promote a broad portfolio of different technologies**
  - **Ensure credibility of the system! Avoid „stop-and-go“ approaches**

- Currently, a well-designed (dynamic) FIT system provides a certain deployment of RES-e fastest

**IMPROVE THE CURRENT SYSTEMS!**

e.g. Feed-in-cooperation DE and ES -> why not a “Club” of TGC – countries (learning from SE)?

## In the long run?

- Re-regulation?
- Priority production from renewables should persist
- Ecological bonus of the magnitude of external cost relief could prevail “eternally” (at least as long as no environmental taxes are introduced)
- However, for sustainable policy -> parallel focus on demand-side conservation of high priority!



# INTERESTED IN FURTHER INFORMATION?

- Download reports from:  
[www . eeg . tuwien . ac . at](http://www.eeg.tuwien.ac.at)  
[www . green-x . at](http://www.green-x.at)  
[www . optres . fhg . de](http://www.optres.fhg.de)

- E-Mail to:

[Reinhard.Haas @ tuwien. ac.at](mailto:Reinhard.Haas@tuwien.ac.at)

The **cost of the cellulosic biofuels**,  $P_{ADV BIO}(n,t)$ , is modeled as decreasing with investments in dedicated R&D through a power formulation:

$$(7) \quad P_{ADV BIO}(n,t) = P_{ADV BIO}(n,0) \cdot (TOT_{R\&D,ADV BIO}(n,t))^{-\eta}$$

where  $\eta$  for the relationship between new knowledge and cost and  $LAG=2$

$$(8) \quad TOT_{R\&D,ADV BIO}(n,t) = \sum_n K_{R\&D,ADV BIO}(n,t - LAG) + \sum_{\tau=t-1}^t I_{R\&D,ADV BIO}(n,\tau)$$

Spillovers: different assumptions on completeness of spillovers (through lag time)

# **Perspectives of the IDA Energy Year 2006 project**

**Per Nørgård  
Risø DTU, Denmark**

**Henrik Lund and Brian Vad Mathiesen  
Aalborg University, Denmark**

# The Danish Society of Engineers' Energy Plan 2030

SUMMARY

# IDA Energy Year 2006 project

## A one-year process

- Involving 1600 professionals

## 2 conferences

- Jan 2006: Opening
- Dec 2006: Concluding

## 40 workshops

- knowledge workshops
- vision workshops
- roadmap workshops

## Energy technologies in 2030

- performance
- price

## 7 themes:

- Buildings
- Transport
- Wind, sun & waves
- Fuel cells, hydrogen, bio & batteries
- Oil & gas
- Industrial processes
- Energy systems

## IDA objectives

### by year 2030

- environment
  - to reduce the CO<sub>2</sub>-emission by 50%
- energy
  - to maintain the security of energy supply
- business
  - to increase the technology export by 200%



# Danish Board of Technology – Energy Combi Scenario

Savings

Energy+

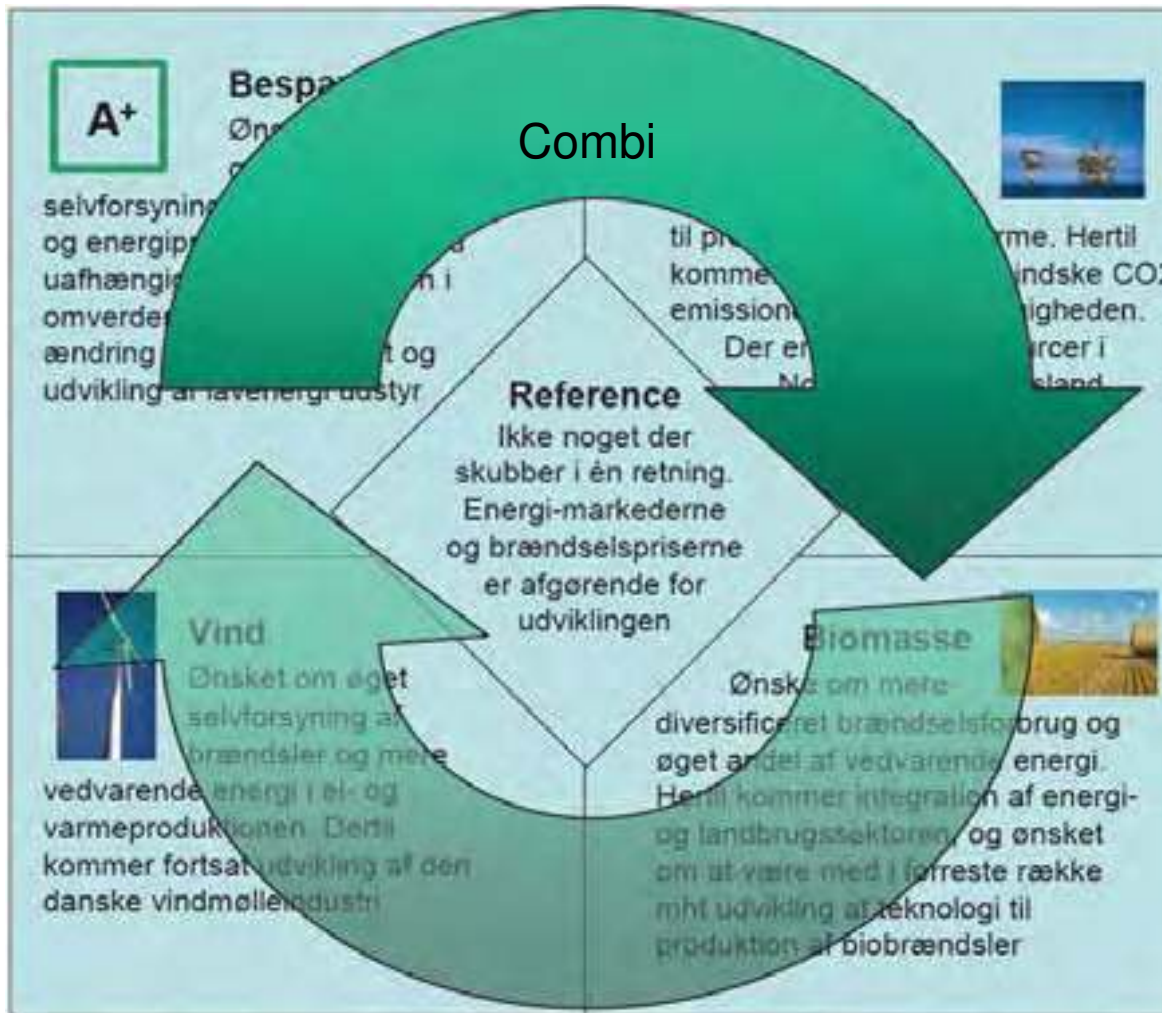

Wind

Bio

## Reference scenario

### DK Energy Strategy 2025

- by The Danish Energy Authority,  
for The Danish Ministry of  
Transport and Energy, 2005
- IDA: 2025 -> 2030

### Energistrategi 2025

Perspektiver frem mod 2025 og

Oplæg til handlingsplan for den  
fremtidige el-infrastruktur





# Reference - DK energy projections

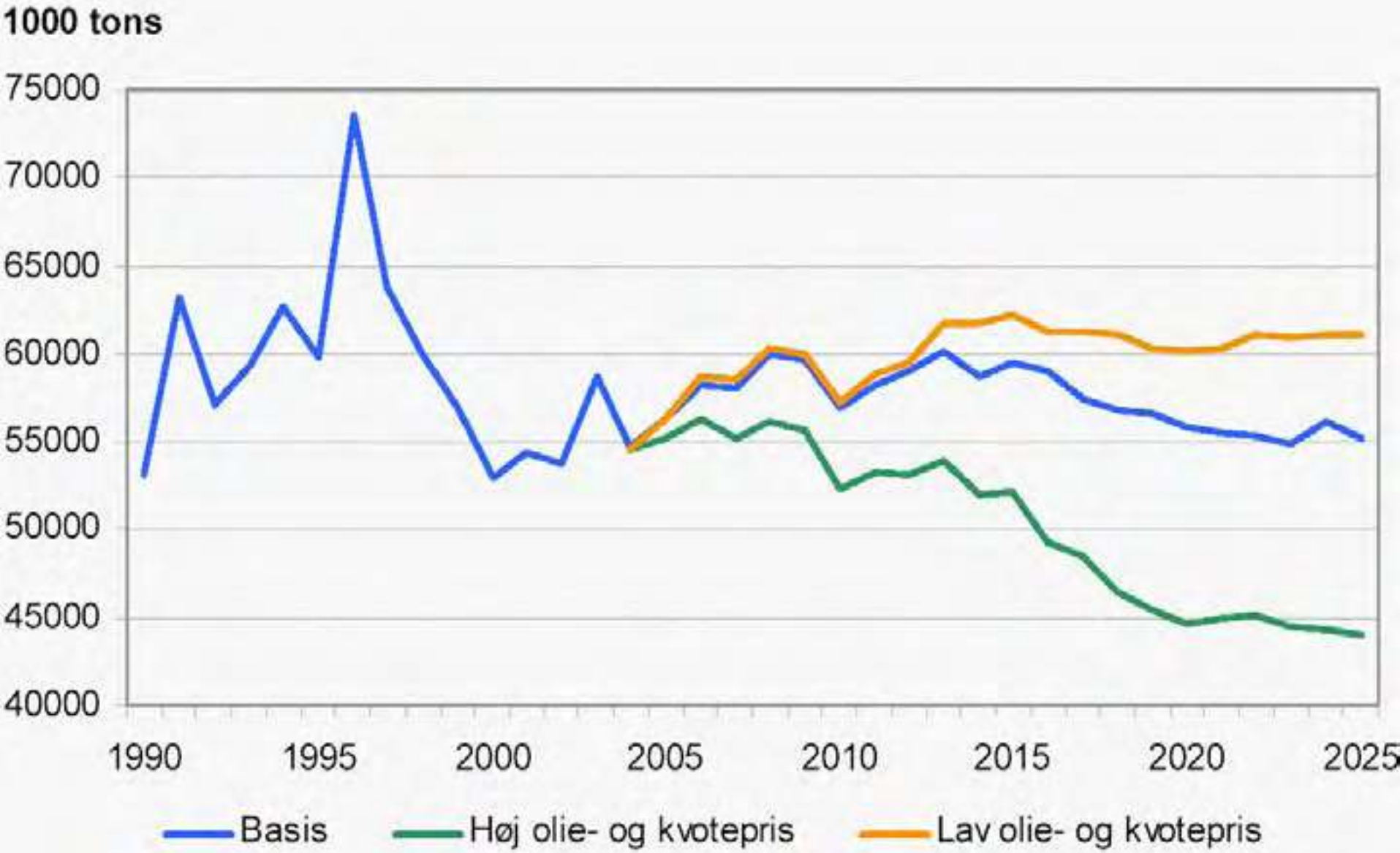

# Reference - DK oil and gas

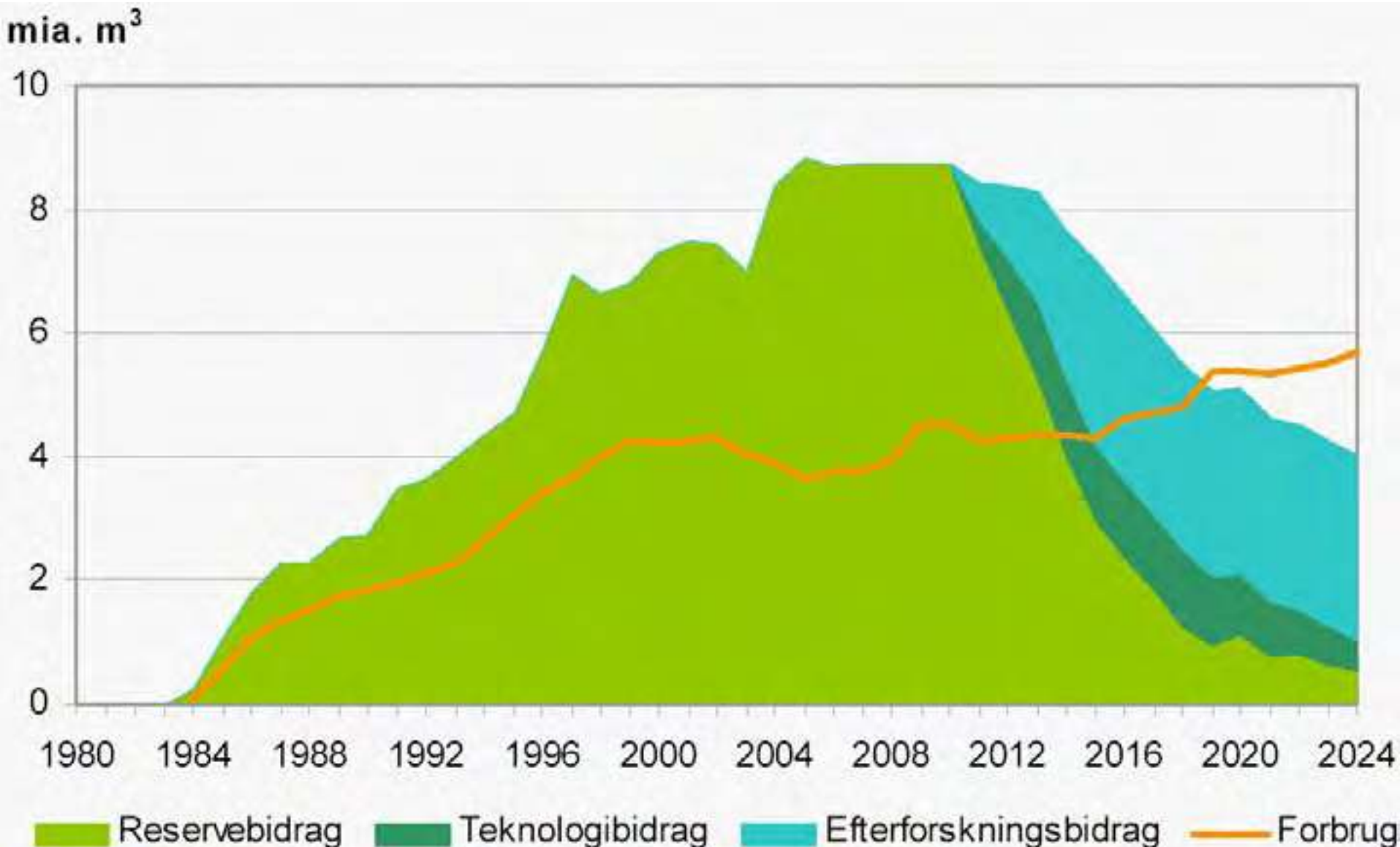

# EnergyPLAN - Energi System Analyse Model

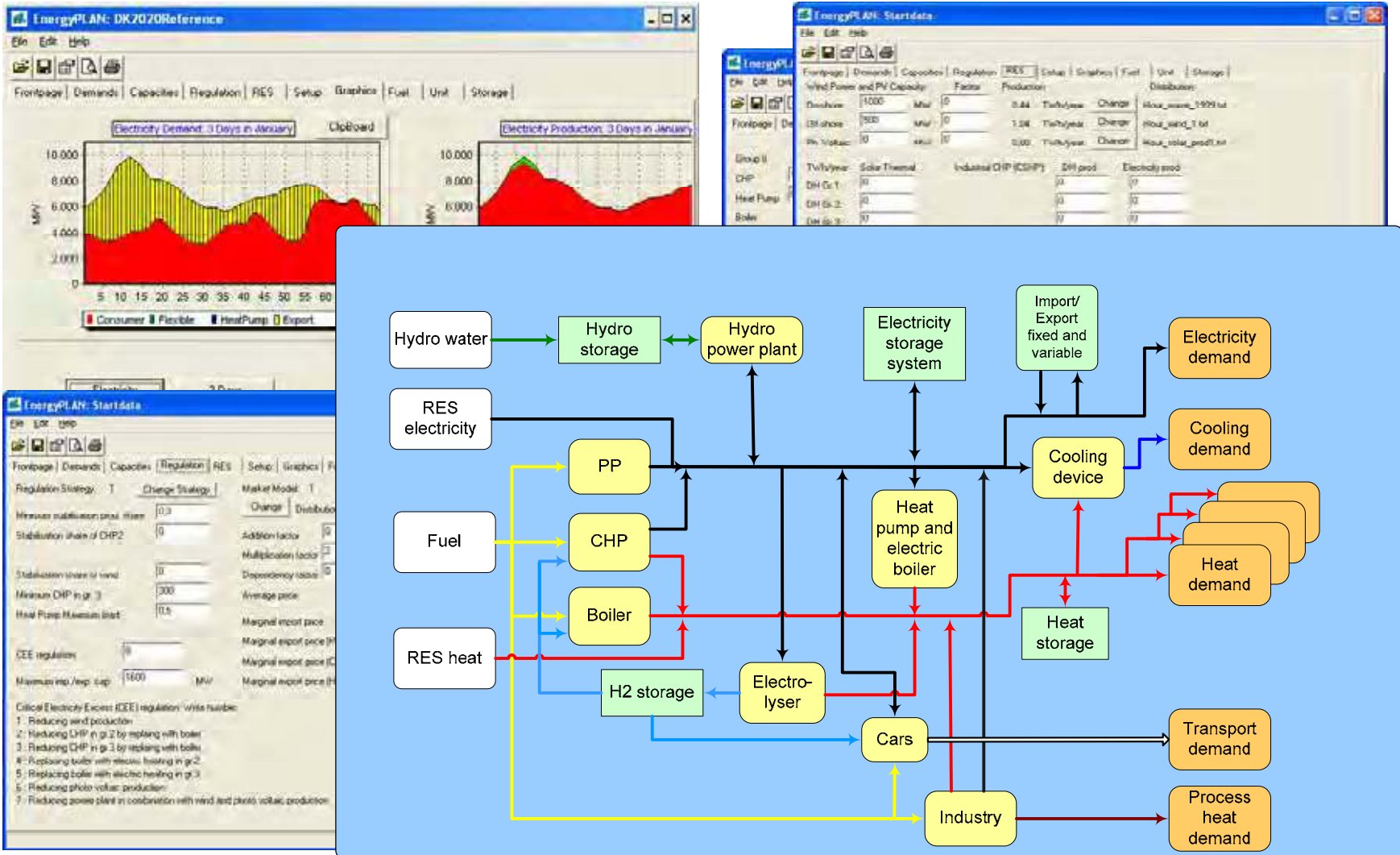

# EnergyPLAN simulation

## EnergyPLAN characteristics:

- Time series analysis on hourly basis
- All energy exchange in one node
- Links between energy sectors
- Include energy storage

## EnergyPLAN simulations include:

- Heat buffer capacity in district heating systems
- Conversion from electricity to heat by heat pumps
- Electricity buffering by electrical cars

## Measures

### Buildings

- Energy for space heating:  
-50 % relative to Ref 2030
- Solar heating:  
30 % of heating
- Electricity consumption:  
-50 % relative to Ref 2030

### Industry

- Fuel consumption:  
-40 % relative to Ref 2030
- Electricity consumption:  
-30 % relative to Ref 2030
- Industrial CHP:  
+20 % electricity
- Biofuels:  
+80 PJ

## Measures

### Wind, sun, wave

- Wind:  
+3000 MW
- Wave:  
5% of electricity in 2030
- Photovoltaic:  
2% of electricity in 2030

### Oil & gas

- North Sea:  
-45 % CO<sub>2</sub> emission

## Measures

### Transport

- Stabilising the total person-transport work
- Air traffic: 50% -> 30% increase (2005 – 2030)
- 20% transport work from road to rail and ship
- Energy efficiency: +30 %
- Biofuels in 2030: 20 %
- Electricity in 2030: 20 %

### Biomass

- In 2030: 30 % of primary



## Results - Primary energy supply

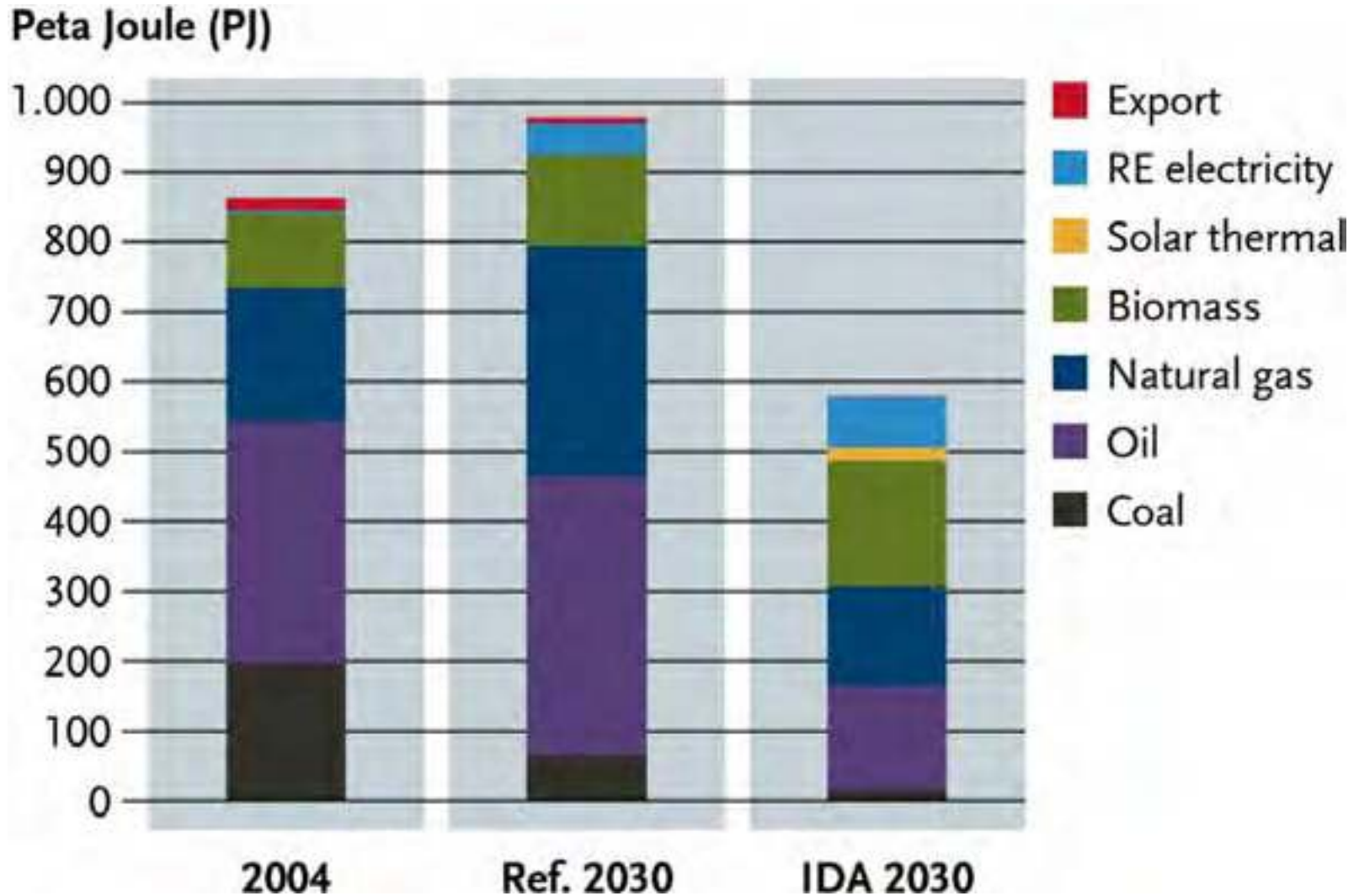



## Results - CO2 emissions

Million ton per year

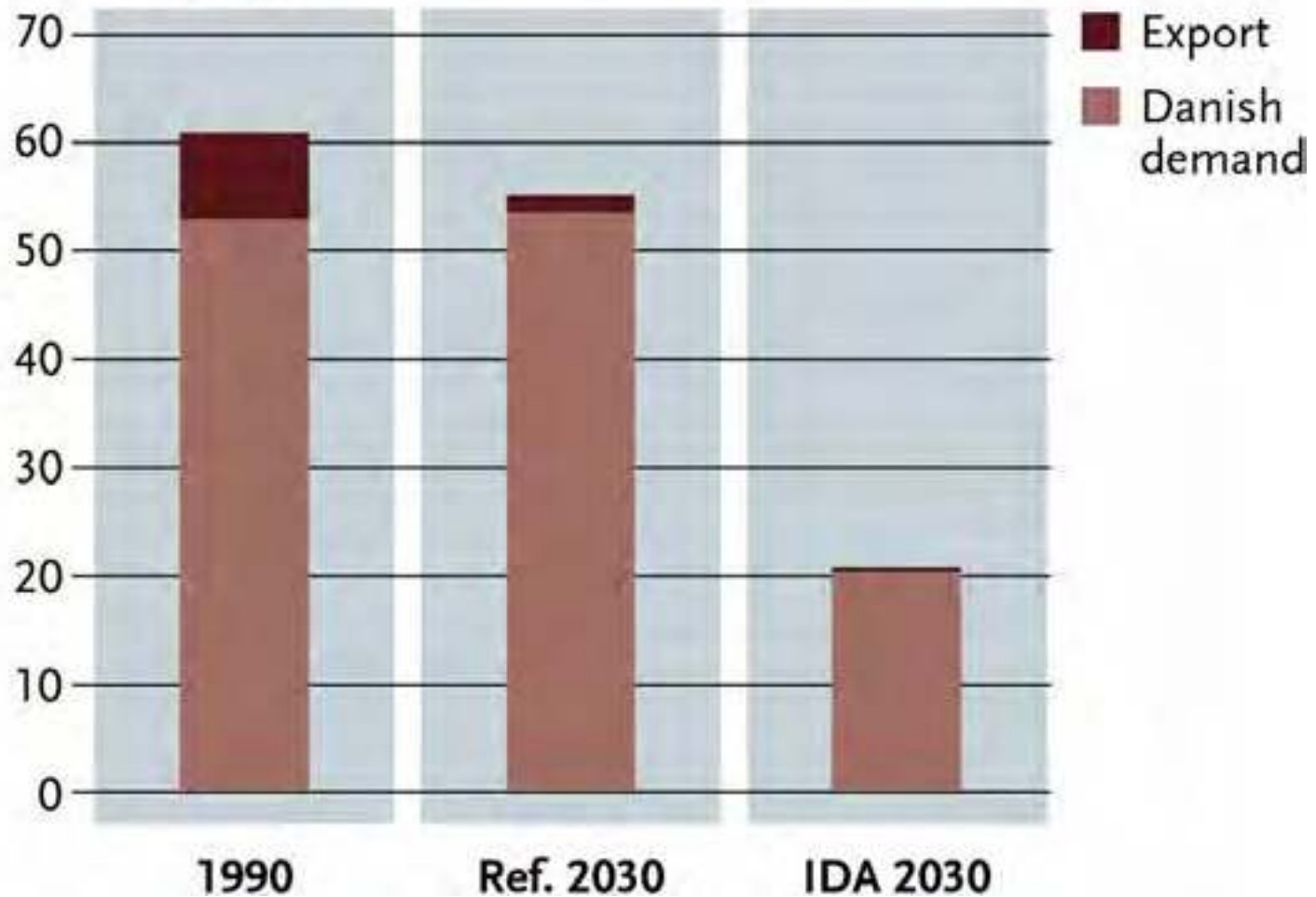

# Results - Business potential

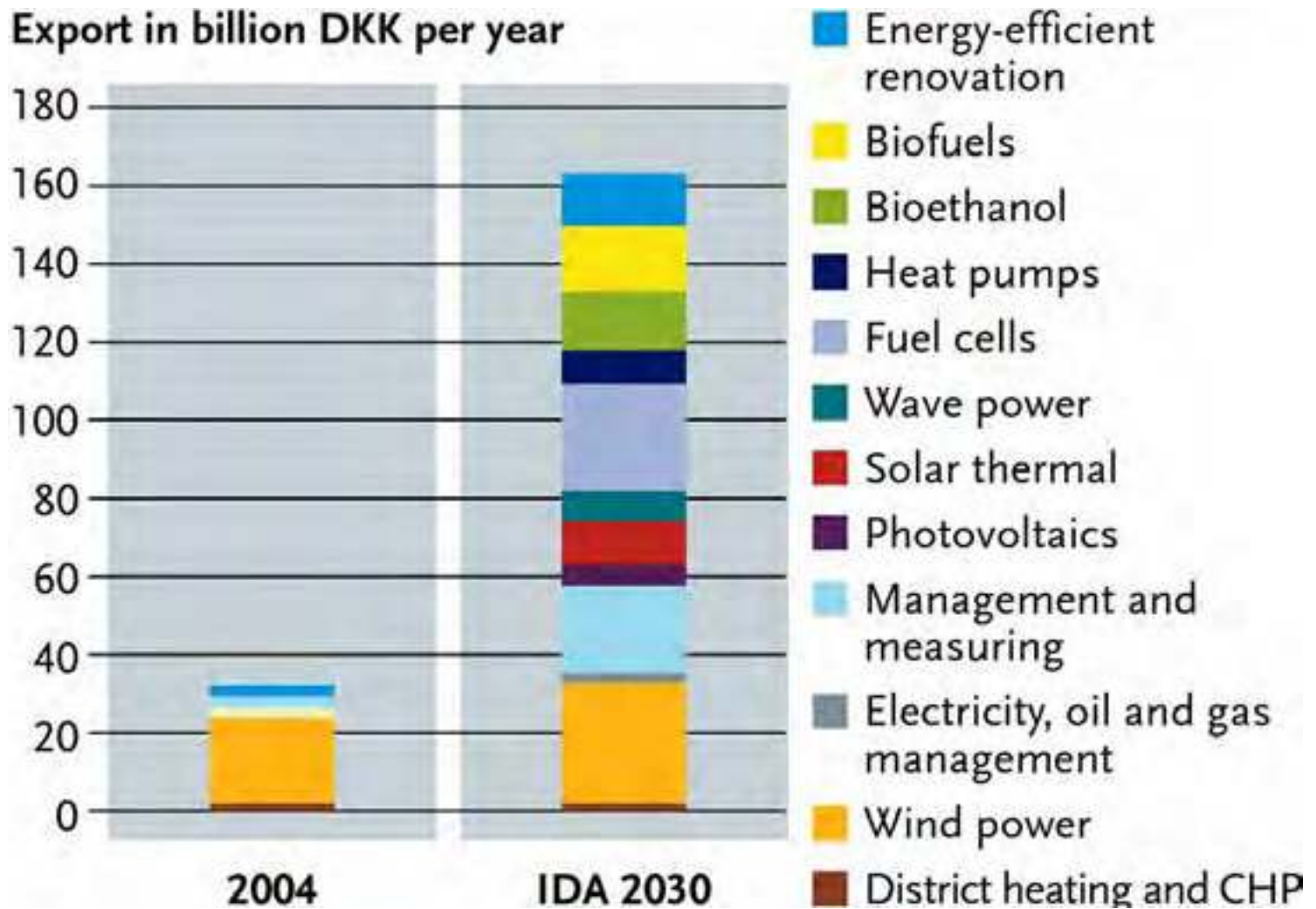

## Results - Economic costs

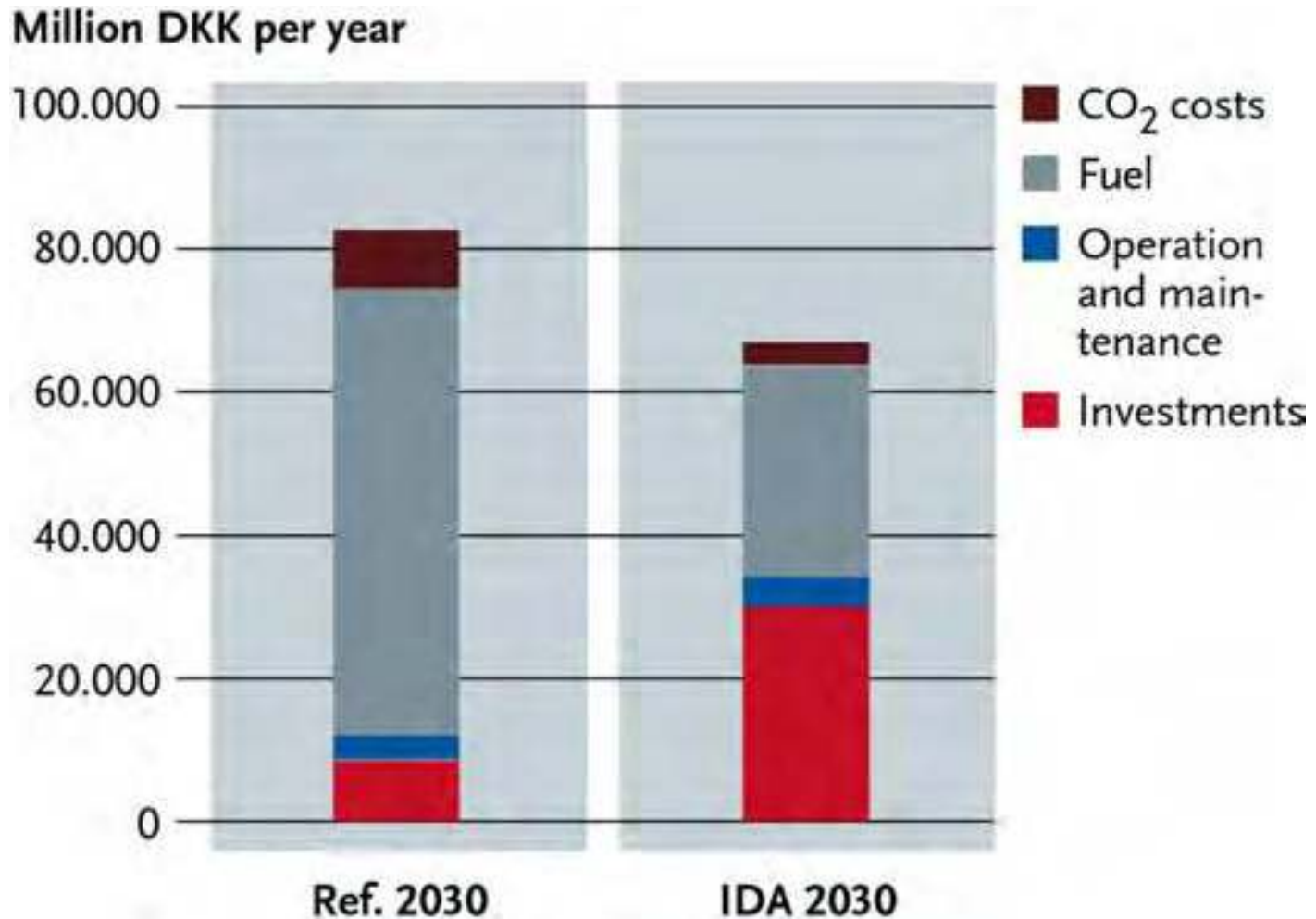

# Sensitivity analysis

Fluctuating oil prices

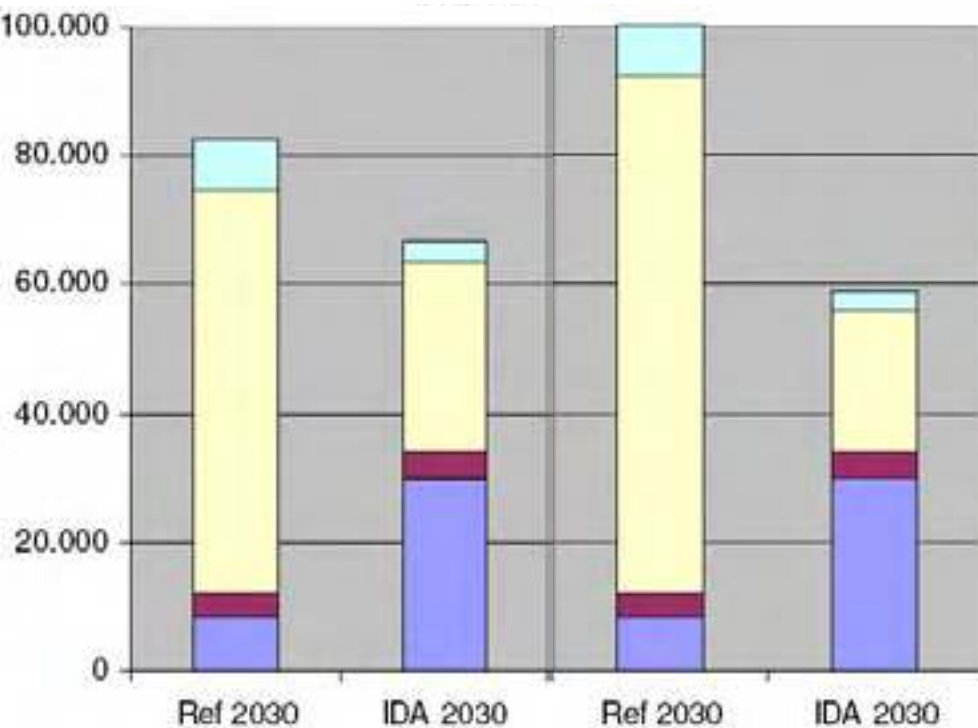

+50% investment costs 6% interest rate

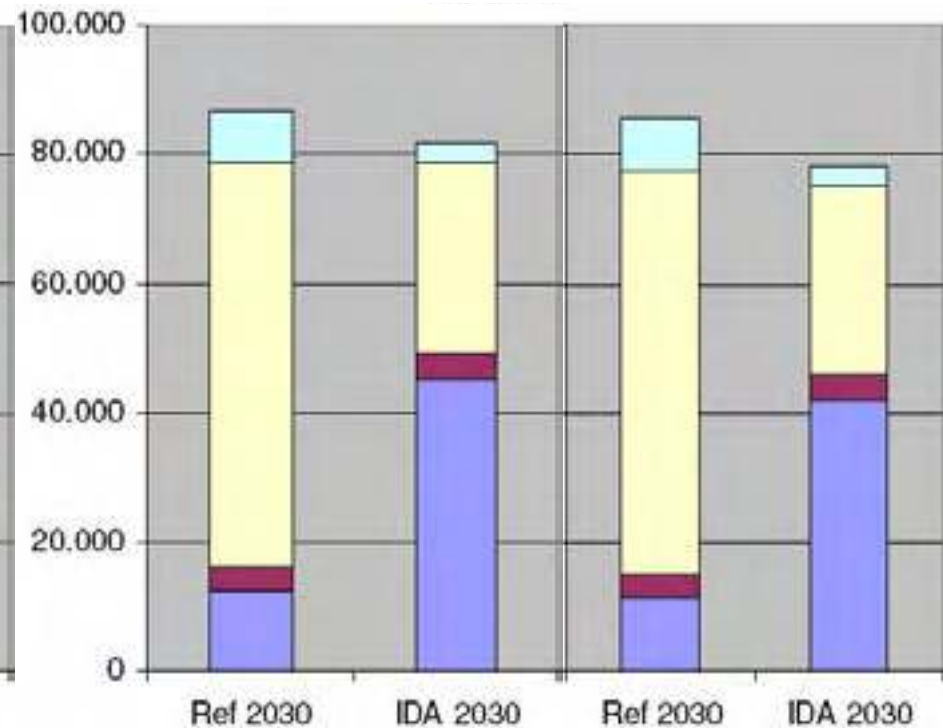

## Conclusion

### The actual figures indicate:

- Energy: -40 %  
Ref 2030: 1000 PJ  
IDA 2030: 600 PJ
- CO<sub>2</sub> emission: -60 %  
1990: 50 mio ton  
IDA 2030: 20 mio ton
- Fossil fuels: -65 %  
Ref 2030: 800 PJ  
IDA 2030: 300 PJ
- Technology export: +500 %  
DKK 30 billion @ 2005  
DKK 160 billion @ 2030
- Costs: -20 %  
Ref 2030: DKK 80 billion  
IDA 2030: DKK 65 billion

### It is both technical possible and economic feasible at the same time in 2030 to achieve:

- less total energy consumption,
- less total CO<sub>2</sub>-emission,
- less fossil fuels consumption and
- increased technology export
- even at reduced economic costs.

### Sustainable solution can only be achieved through:

- Energy conservation
- Energy efficiency
- System solutions
- Flexibility
- Couplings between energy sectors



Millioner kroner pr. år

Dansk Referene 2030

Ingeniørforeningens energiplan 2030

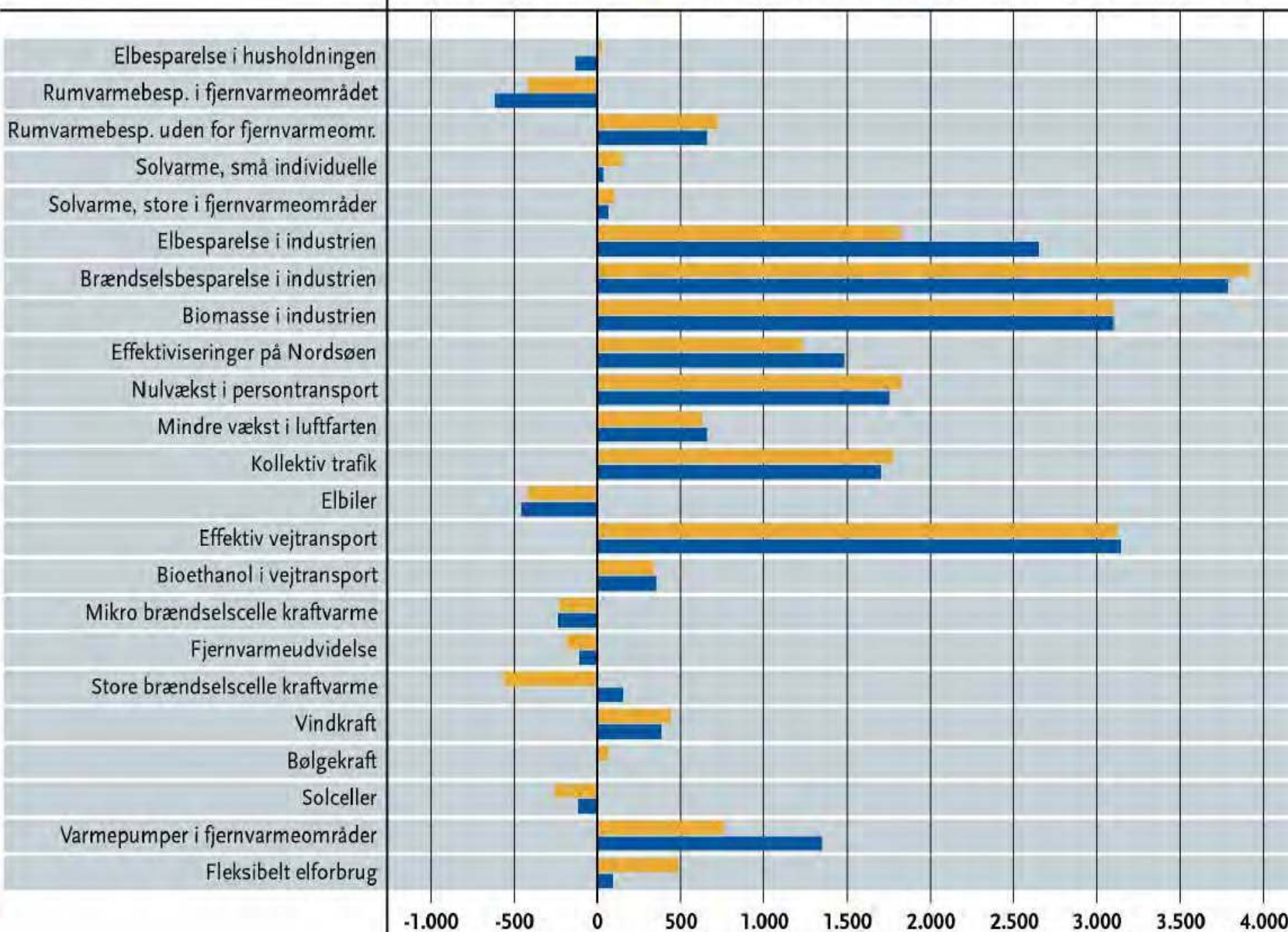

# Example: The IBUS bio-refinery concept

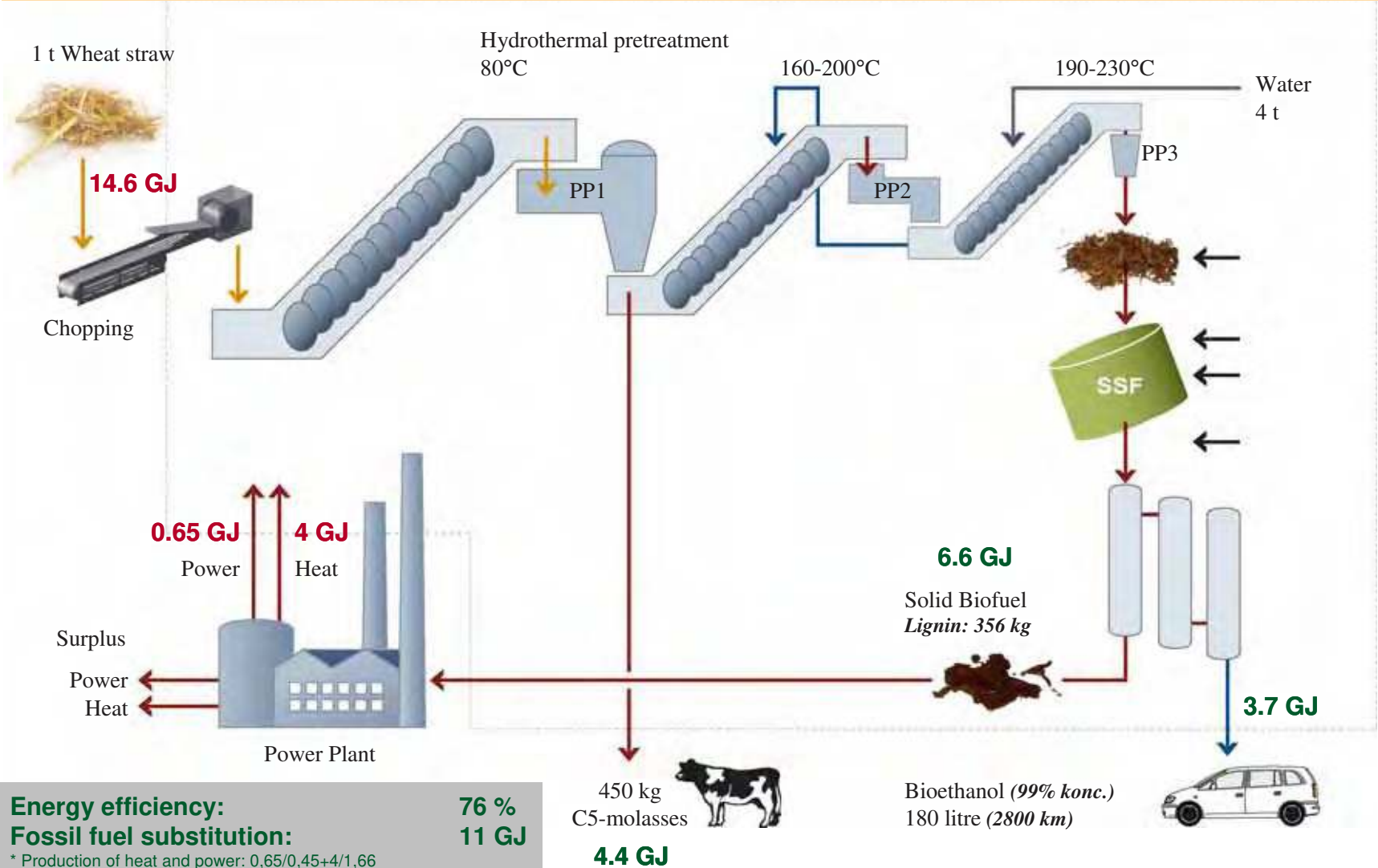



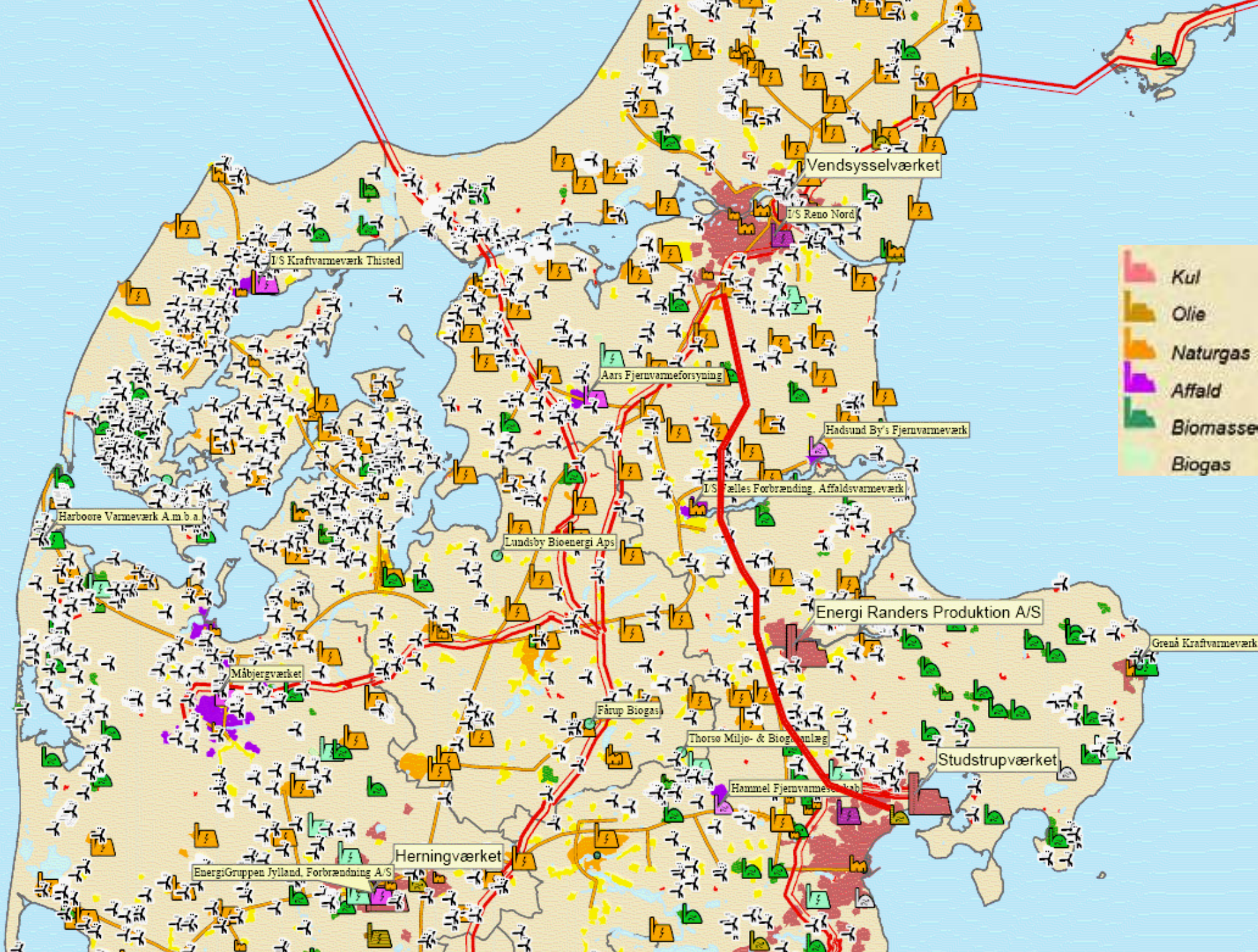

Kul

Olie

Naturgas

Affald

Biomasse

Biogas

Vendsysselværket

I/S Reno Nord

I/S Kraftvarmeværk Thisted

Aars Fjernvarmeforsyning

Hadsund By's Fjernvarmeværk

I/S Sælles Forbrænding, Affaldsvarmeværk

Lundsby Bioenergi Aps

Energi Randers Produktion A/S

Grenå Kraftvarmeværk

Harboøre Varmeværk A.m.b.a.

Måbjergværket

Fårup Biogas

Thorsø Miljø- & Biogas anlæg

Studstrupværket

Hammel Fjernvarmeforsyning

Herningværket

Energi Gruppen Jylland, Forbrændning A/S



## Some of challenging discussions at IDA workshops

### Buildings

- New building energy standards – but 70 % of the buildings in DK in 2030 are from before today
- District heating infrastructure in the future?

### Biomass feedstock is a limited resource

- CO<sub>2</sub>-reduction: CHP
- Independency of oil: transport
- Business: bio fuels technologies
- Biomass for energy -> increased food prices

### Transport sector

- Energy efficient technologies are present – but are not introduced!
- -10 % person road transport -> +50 % rail transport
- Energy and CO<sub>2</sub> related to international transport not included!
- International person transport: alternatives to fly?

## IDA recommendations (€ 1.5 billion / year)

- The existing agreement on **energy savings** should be extended and continued (1.7 % annual reductions in energy consumption).
- An **industry energy savings fund** should be established (€ 100 mio annually).
- A **heat conservation fund** should be established (€ 100 mio annually).
- € 30 billion should be invested in the Danish **rail road system** over the next 30 years.
- The Danish national funds for **research, development and demonstration** should be increased to € 100 mio annually.
- **Innovation markets** for renewable energy technologies should be established by quotas in order to accelerate the development.
- All costs – including **externalities** – should be included in the market prices.
- **Popular engagement** in energy savings and renewable technologies should be supported.
- **CO2 quotas** should be sold through biddings.
- A thorough service control of all **energy taxes** and tariffs should be made.
- 100 % **renewable energy cities** should be established in Denmark.

# IDA 2050 100 % RE – Primary energy supply (PJ)

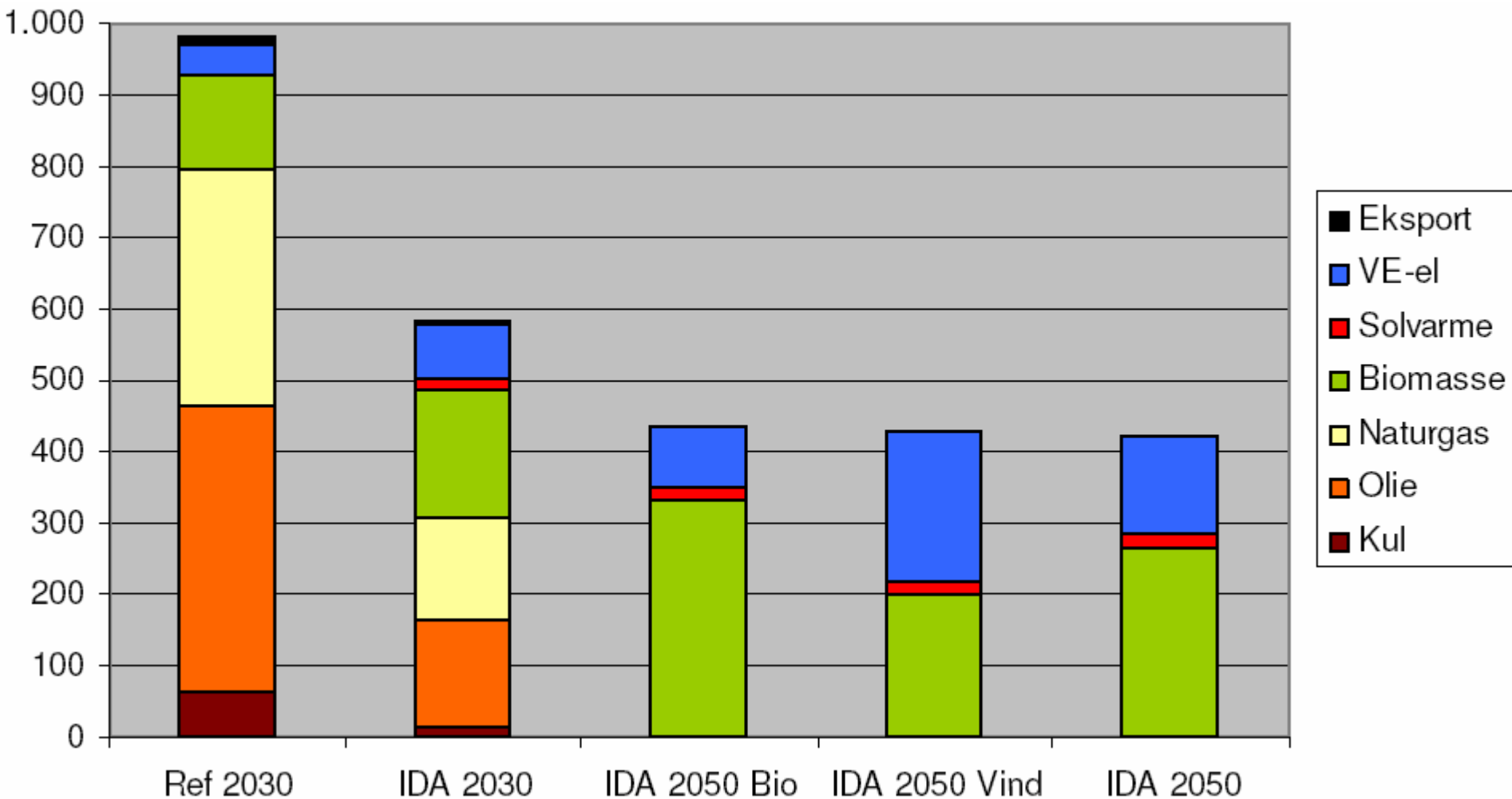

# Follow-up

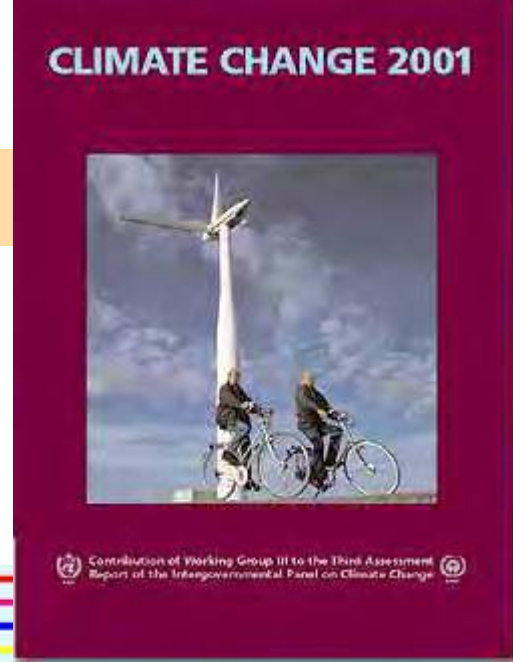

# En visionær dansk energipolitik

Januar 2007

# 2025



**Thanks**

[per.norgaard@risoe.dk](mailto:per.norgaard@risoe.dk)

<http://ida.dk/Netvaerk/Energiaar+2006>



# **Integrated European Energy RTD as part of the innovation chain to enhance renewable energy market breakthrough**

**Professor Peter Lund  
Helsinki University of Technology, Finland  
[peter.lund@tkk.fi](mailto:peter.lund@tkk.fi)**

**Risö International Energy Conference 2007  
22-24 May 2007**

# Observations from the past on market penetration of new energy technologies



- It may take **decades** to reach a noteworthy share on world markets
- The public support required to bring a new major energy source into world-scale may be some **hundred billion dollars** in total

Figure. Penetration of selected energy technologies (MW).

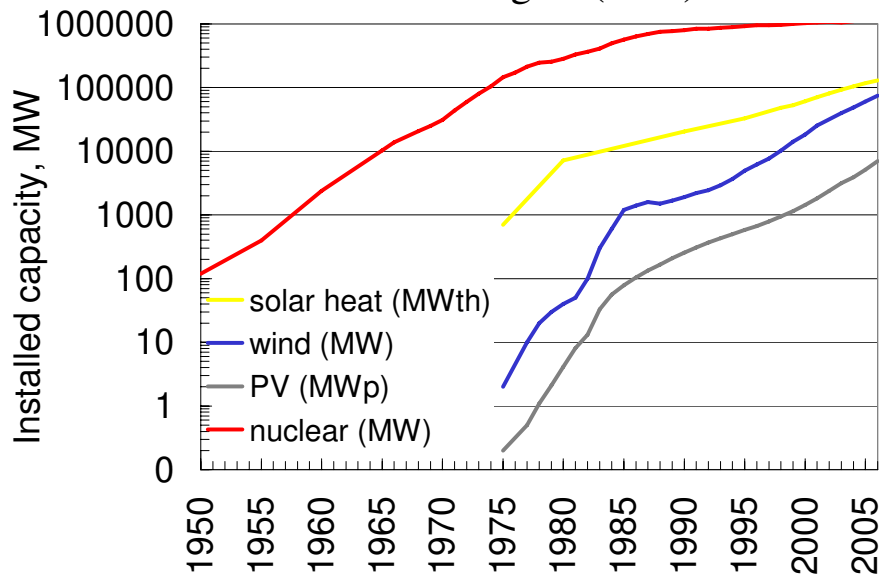

Table . Estimated public support to selected technologies in billion \$ (2003 prices).

Technology	All support 1947-73	Market deployment 1974-2004	R&D 1974-2004	Total 1947-2004
PV	0	10.6	8.3	19.2
Solar th.	0	10.3	3.4	13.7
Wind	0	49.1	4.2	53.3
Nuclear	176.6	0	157	333.6

# Public and private support to energy technology R&D has dropped dramatically



- Public energy R&D support of Member States is <math>< 1/3</math> of the 1980's level; renewables only a small share
- Energy companies invest «0.5% of turnover in R&D
- Energy in EU's 7<sup>th</sup> FP is <math>< 15\%</math> of the budget ; 20 years ago it was 50%
- EU's Advisory Group on Energy (FP6) advised a 4x increase in energy R&D funding

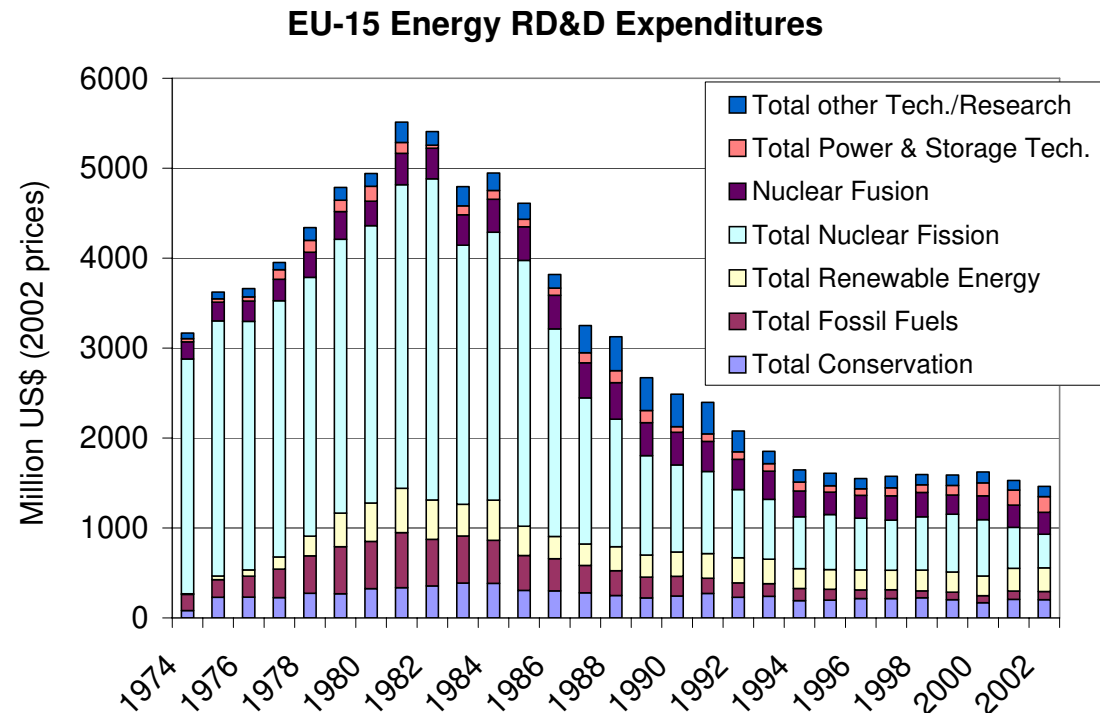

Source: European Commission, IEA



# European Strategic Energy Technology Plan



- “The European Strategic Energy Technology Plan (SET-Plan) calls for a more **integrated approach** to match the most appropriate set of policy instruments to the needs of different technologies at different stages of the development and deployment cycle”. [An Energy Policy for Europe, European Commission, 10 Jan. 2007]
- Key objectives for energy technology: 1) to **lower the cost** of clean energy, 2) to put **EU industry** at forefront of low carbon technology

A vision to match the long term challenge competitively

2020

2030

2050

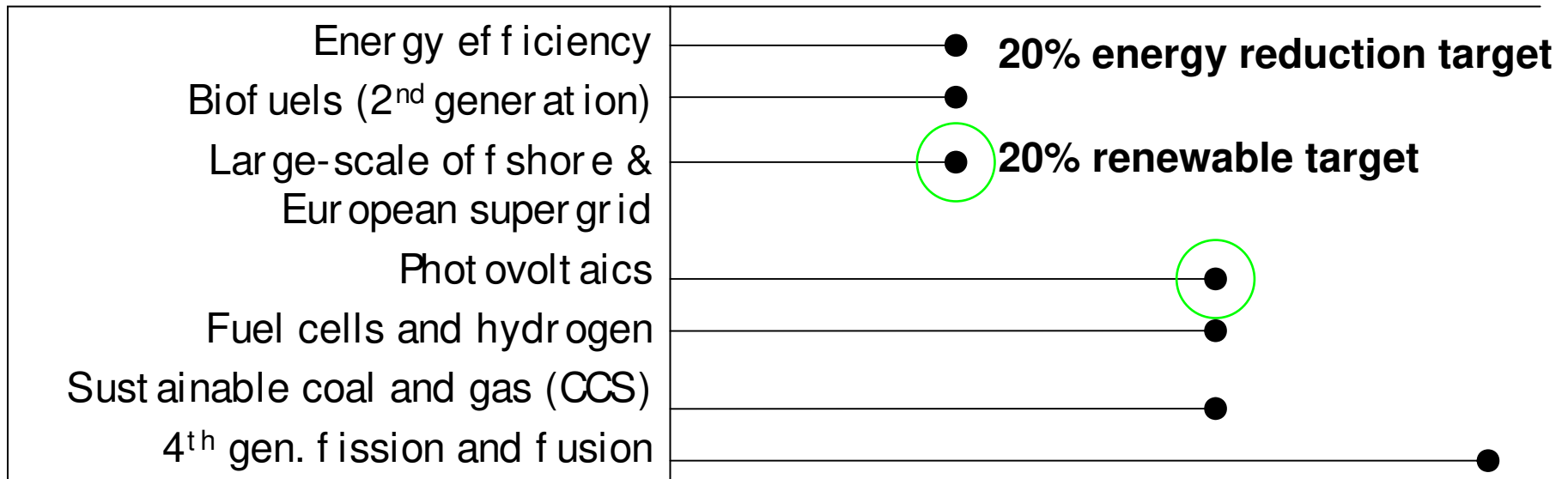



# Outline of the presentation

- Starting point: Advisory Group of Energy's recommendations and concerns on energy R&D from 2006 and the EU's Energy Policy Communication from 2007
- Aim: Investigating future market breakthrough of renewable energy technologies (€ and yrs); key parameter is cost-effectiveness
- Scope: matching policy measures (technology, market support) with specific technology needs over the whole innovation process
- Approach: modeling the commercialization process with links to policy measures

# Three important elements/ aspects in an integrated RTD strategy



## 1. Commercialization process of new innovations or improvements of energy technologies

- precedes the more massive market penetration and is very development intensive and needs strong public support

## 2. Technology diffusion process

- describes the market share of the new technology over time once the 'take-off' has occurred after market introduction and the new technology is becoming competitive against the prevailing ones;

## 3. Policies and instruments

- enhance above processes to enable full commercial market breakthrough
- includes also the overall policy needed to master the whole commercialization process.

# Commercialization process

- The commercialization process involves several stages (non-linear)
- Several endogenous and exogenous factors affect breakthrough
- Distance from market
  - Incremental improvements for existing products << radical innovations without established markets

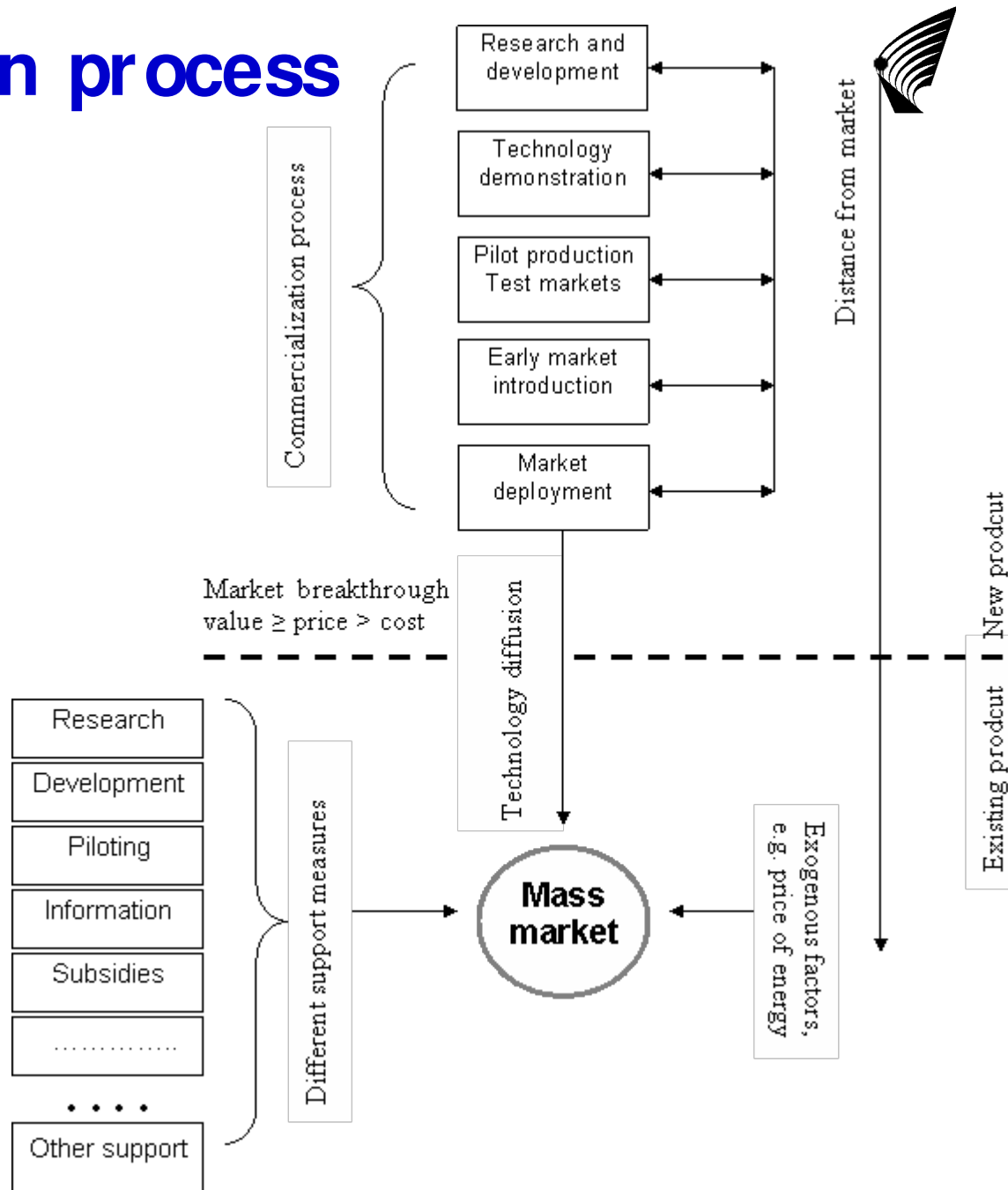



# Technology diffusion

- Boundary between commercialization process and market penetration often overlapping
- Penetration described by diffusion (speed of penetration, inertia)

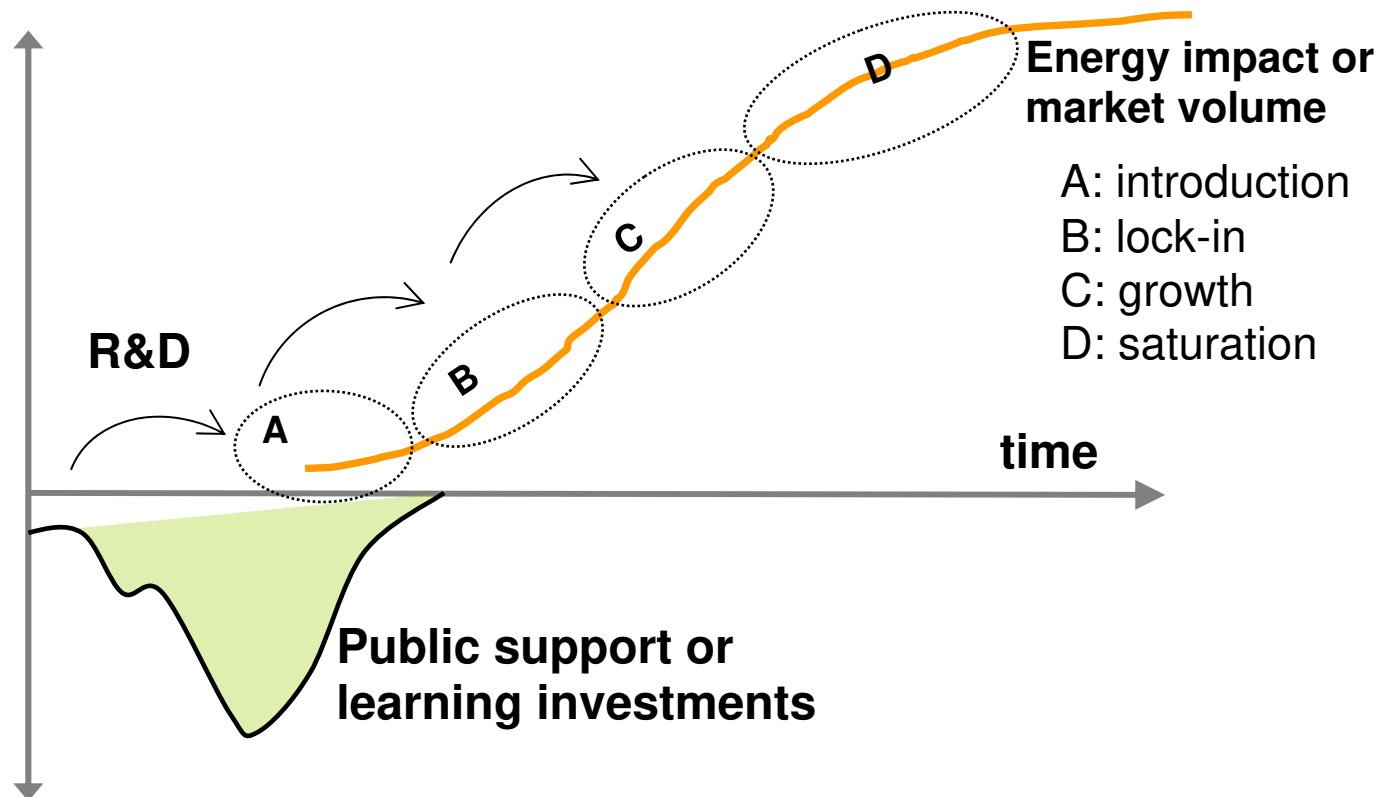

# Policy instruments in an integrated strategy

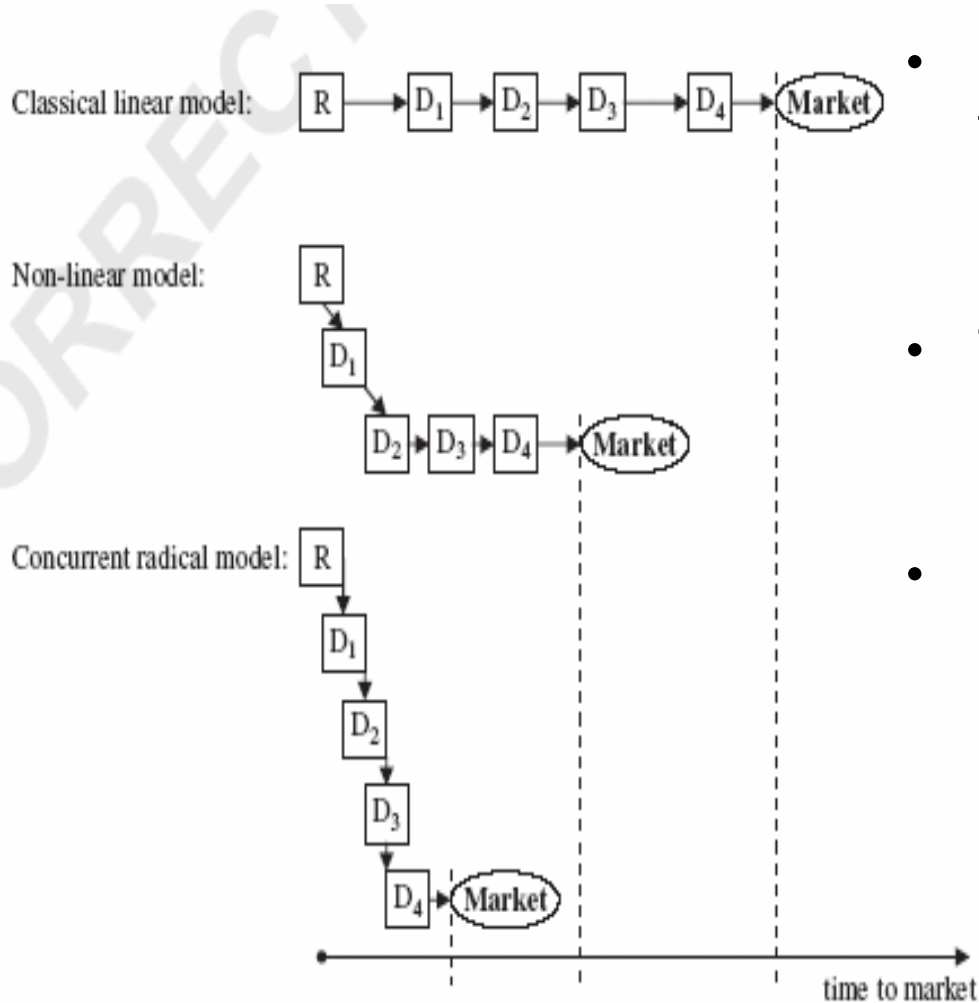

- Here policy instruments consider the whole commercialization process and aim at a full market breakthrough
- Technology push and market pull measures are interlinked and considered in parallel
- Catalyzing measures to boost the commercialization
  - market forces and mechanisms (close cooperation between the different market players)

Examples of different profiles of the innovation chain. R=research, D<sub>1</sub>=development, D<sub>2</sub>=demonstration (pilot production), D<sub>3</sub>=dissemination, D<sub>4</sub>=deployment

# Combined diffusion and learning model



- The tool combines price-conditioned and segmented technology diffusion with an endogenous learning model
- Three interlinked submodels: 1) calculation of the production cost of energy (C), 2) estimation of the market volume increase ( $dV_t$ ) and 3) cost reduction ( $dC_V$ )
- The speed of market penetration is described by a diffusion model
- Cost reductions are described by endogenous learning, i.e. learning by doing and by using and economies of scale.

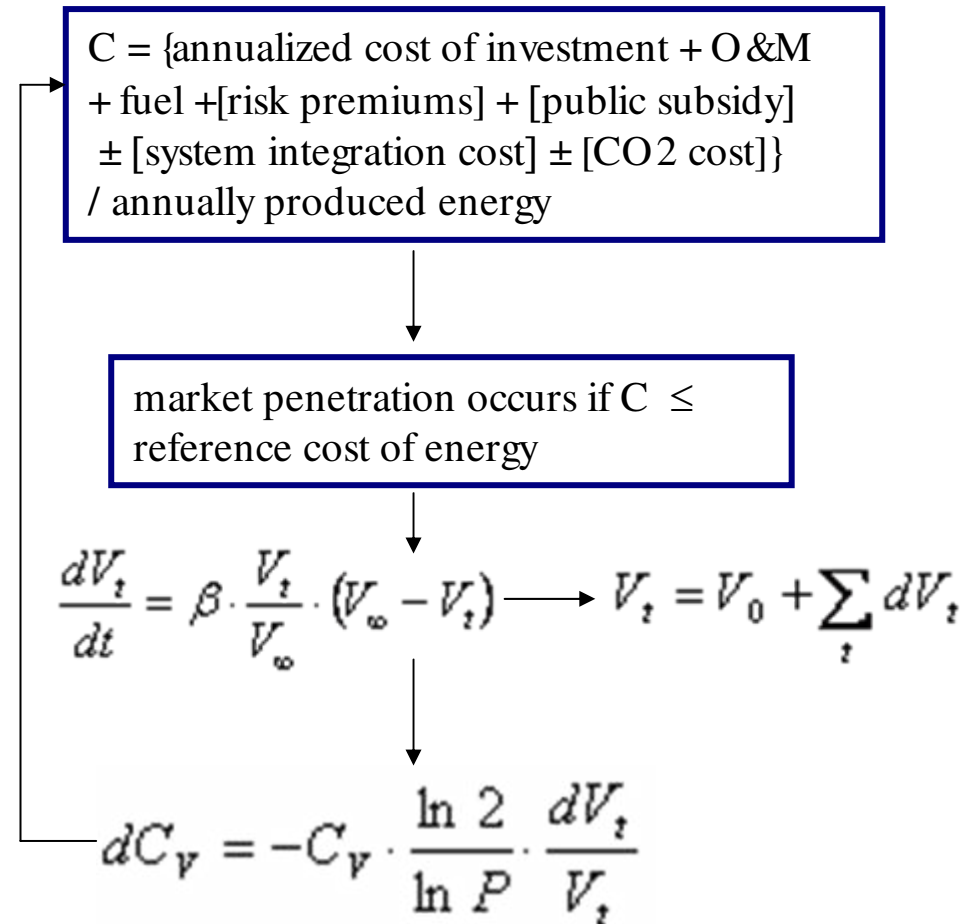

# Linking policies and strategies to the model

- Policy measures improve the economic competitiveness of the new technologies (C) and influence the penetration rate ( $\beta$ ) which leads to increased volume (V)
- Examples on how policies (both RTD and market deployment) may influence the costs of the new technology (a-f)
  - **a: classical learning curve**
  - **b: strong R&D effort**
  - **c: too high subsidies, low competition, bottlenecks**
  - **d: c+ measures**
  - **e: demand >> supply, oversized**
  - **f: e+ measures**

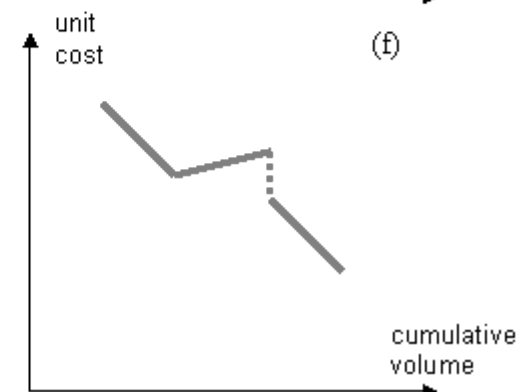
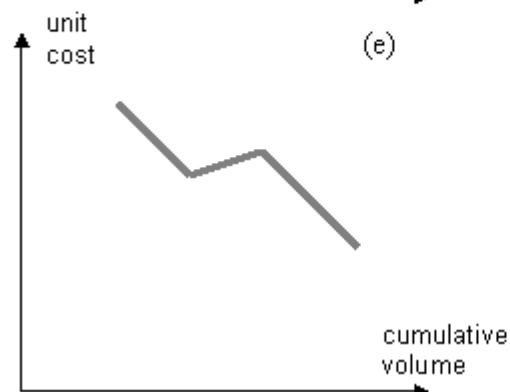
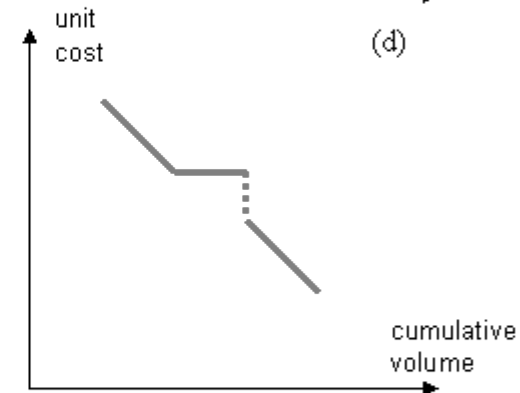
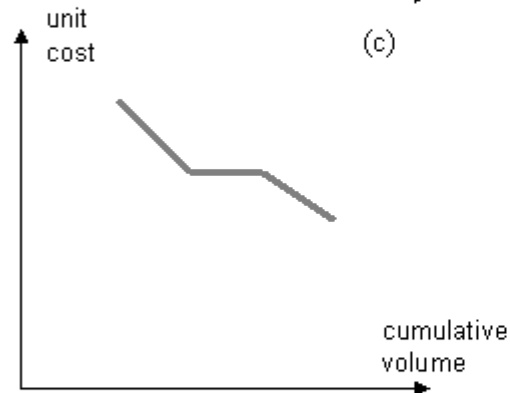
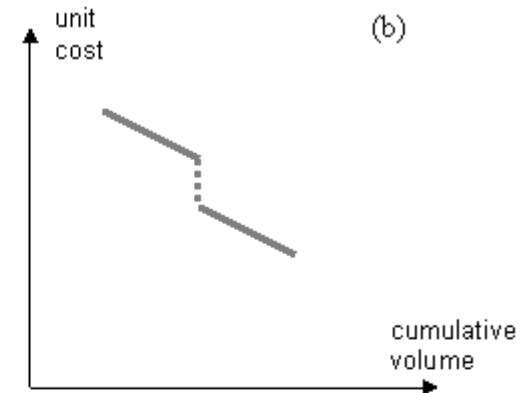
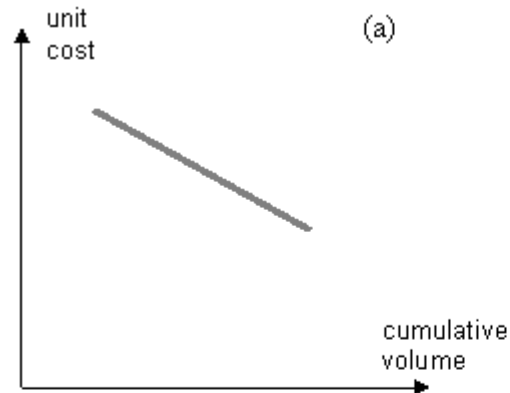



# Examples of the use of the model



- **Case: Photovoltaics – effects of a major R&D effort**
  - PV is marginal but growing fast, 2-4 x more expensive than consumer electricity
  - Base case: feed-in-tariffs are used to ensure competitiveness; Hypothesis: a concerted RTD initiative (JTI) could be justified; a 30% cost reduction possible in 10 years through stronger R&D
- **Case: Wind – impact of possible market disturbance**
  - Wind >1% of world electricity and fast growing, marginally more expensive
  - Base case: feed-in-tariffs are used to ensure competitiveness; Hypothesis: 1) demand for wind >> supply and could cause a short market disturbance, i.e. for 2 years costs a) stagnate and b) +5%/yr 2) in large investments the cost of capital becomes important



# Case PV: penetration results

- **PV ~ 1% of world electricity at t=30 yrs or around 400 TWh**
- **PV becomes fully competitive at t=20 yrs in consumer segments in EU**

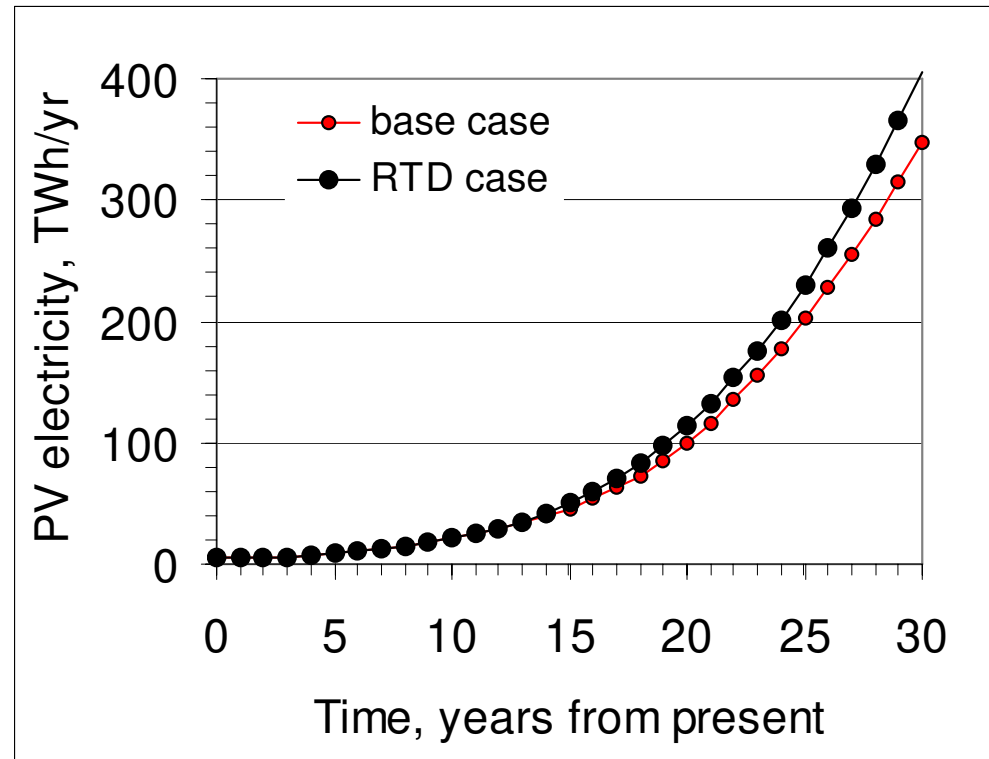



## PV (2): effects of technology jump

- The concerted R&D strategy case could save 150 billion € in investment costs and 33 billion € of public support in investments over the next 30 years

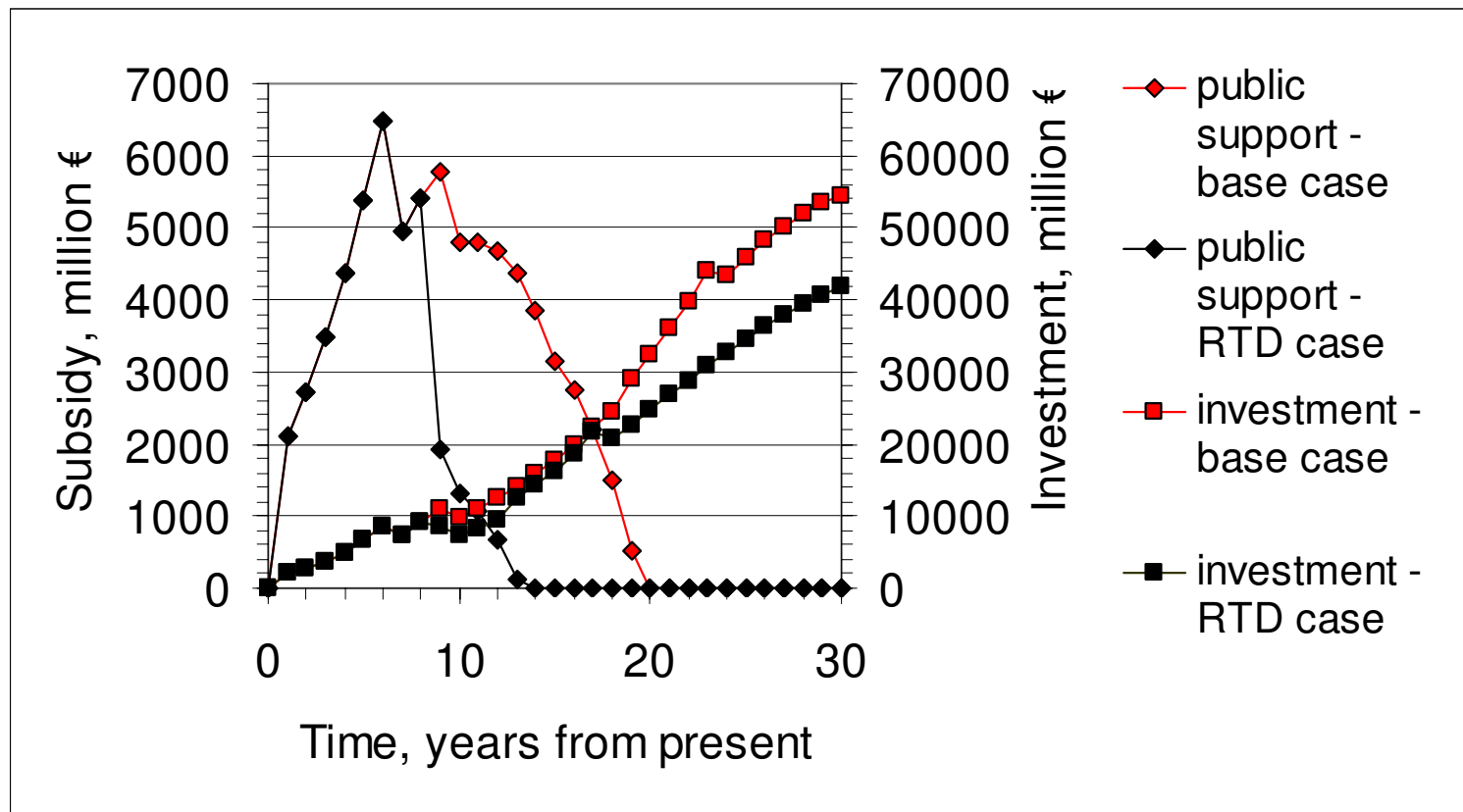



# Case wind: penetration results

- Wind 10% of world electricity at  $t=30$  yrs; 20% in EU
- The cost of wind-electricity is halved in 30 years
- Cost-effective (non-subsidized) penetration starts at  $t=10$  years in EU-onshore and  $t=20$  yrs in EU-offshore segments
- Market saturation in some segments

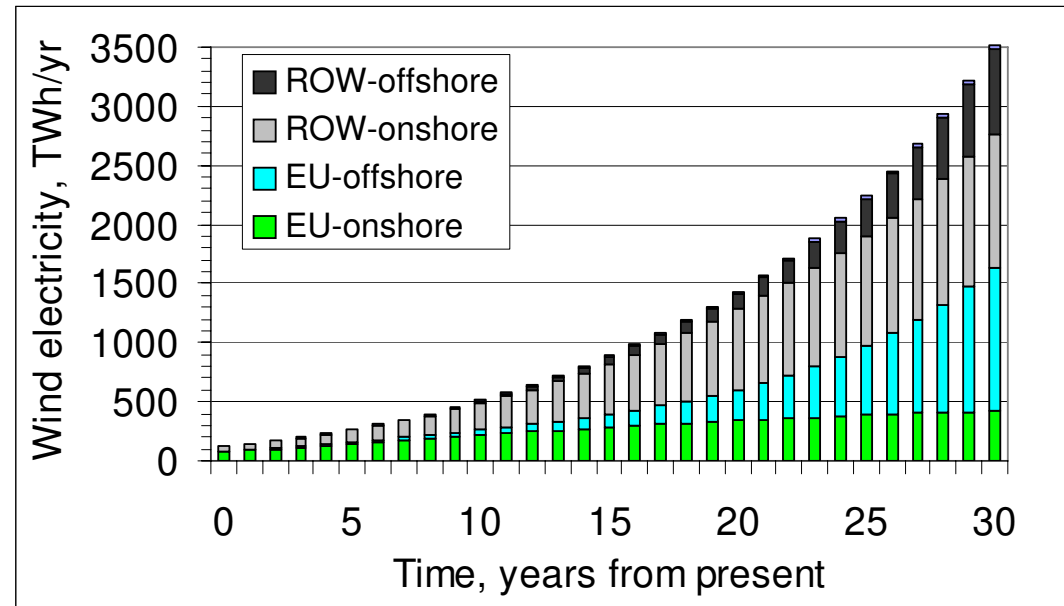



## Wind (2): effects of disturbances

- A market disturbance of 2 years could mean 100 billion € extra investment cost over 30 years; 30 billion € (learning stagnation) – 37 billion € (cost disturbance) more public subsidies
- Advantageous loans could lower the public support needed by 85% and save 70 billion € in the base case

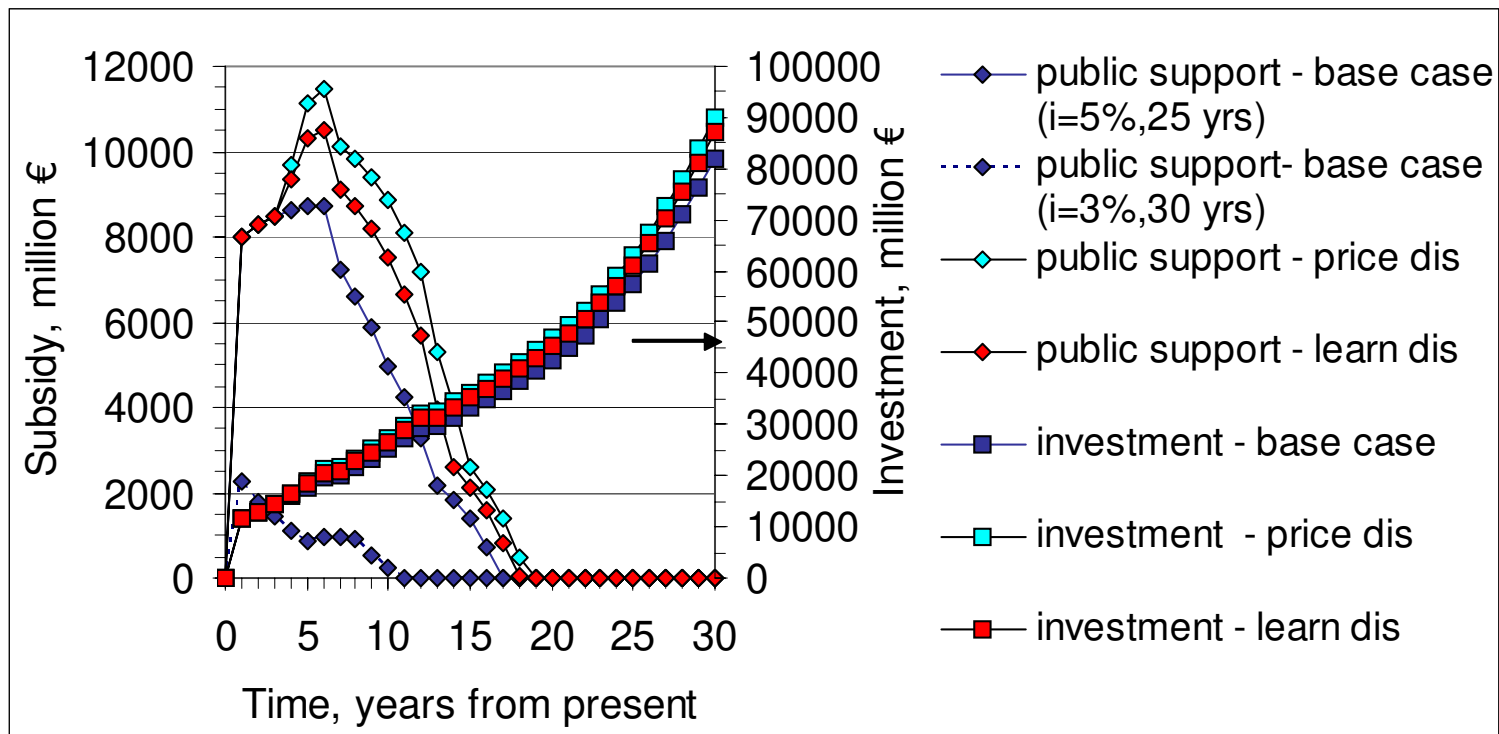

# Observations and conclusions (1)



1. Distance from the cost breakeven point affects the optimal balance between technology push and market pull actions
  - if far away from the commercial breakthrough, focused R&D efforts to enable technology jumps could be more effective than market deployment
  - in case of PV the economic benefits from a strong joint European R&D initiative would be highly motivated
  
2. When reaching higher volumes and exercising strong market pull measures to accelerate market growth even short disturbances in technology cost trends may turn out be costly
  - careful planning of the subsidy levels to balance possible supply/demand bottlenecks is stressed
  - in case of wind a planning of joint European policies could be highly motivated



## Observations and conclusions (2)

3. Full commercialization of new energy technologies needs patient and continuous public support
  - A long time horizon is most likely necessary (10-20 years), public support should be viewed as an investment with long pay-off
  - Several factors may change the total financial support needed
  - Involving European financing bodies in the investments could enable cheaper capital costs

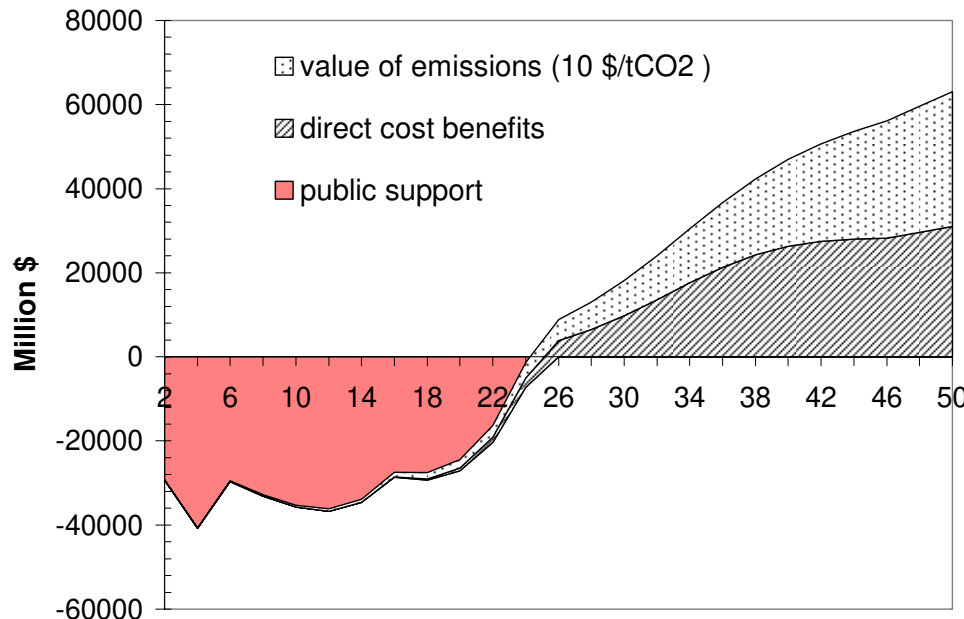

Illustration of the pay-back of public support for PV over 50 years

# Impacts of high energy prices on long-term energy-economic scenarios for Germany

**Volker Krey, Dag Martinsen, Peter Markewitz**

Research Centre Jülich, Institute of Energy Research - Systems Analysis and Technology  
Evaluation (IEF-STE), Jülich, Germany

**Manfred Horn**

DIW Berlin, Berlin, Germany

**Felix Chr. Matthes, Verena Graichen, Ralph O. Harthan, Julia Repenning**

Öko-Institut, Berlin, Germany



# Motivation

- „new“ energy price levels since 2004
- energy-economic scenarios do/did not cover price levels
- compilation of adapted scenarios
- analysis of impacts:
  - supply structures
  - competitiveness of energy-saving measures
  - resulting CO<sub>2</sub>-emissions

# Energy Price Scenarios

## Reference Scenario

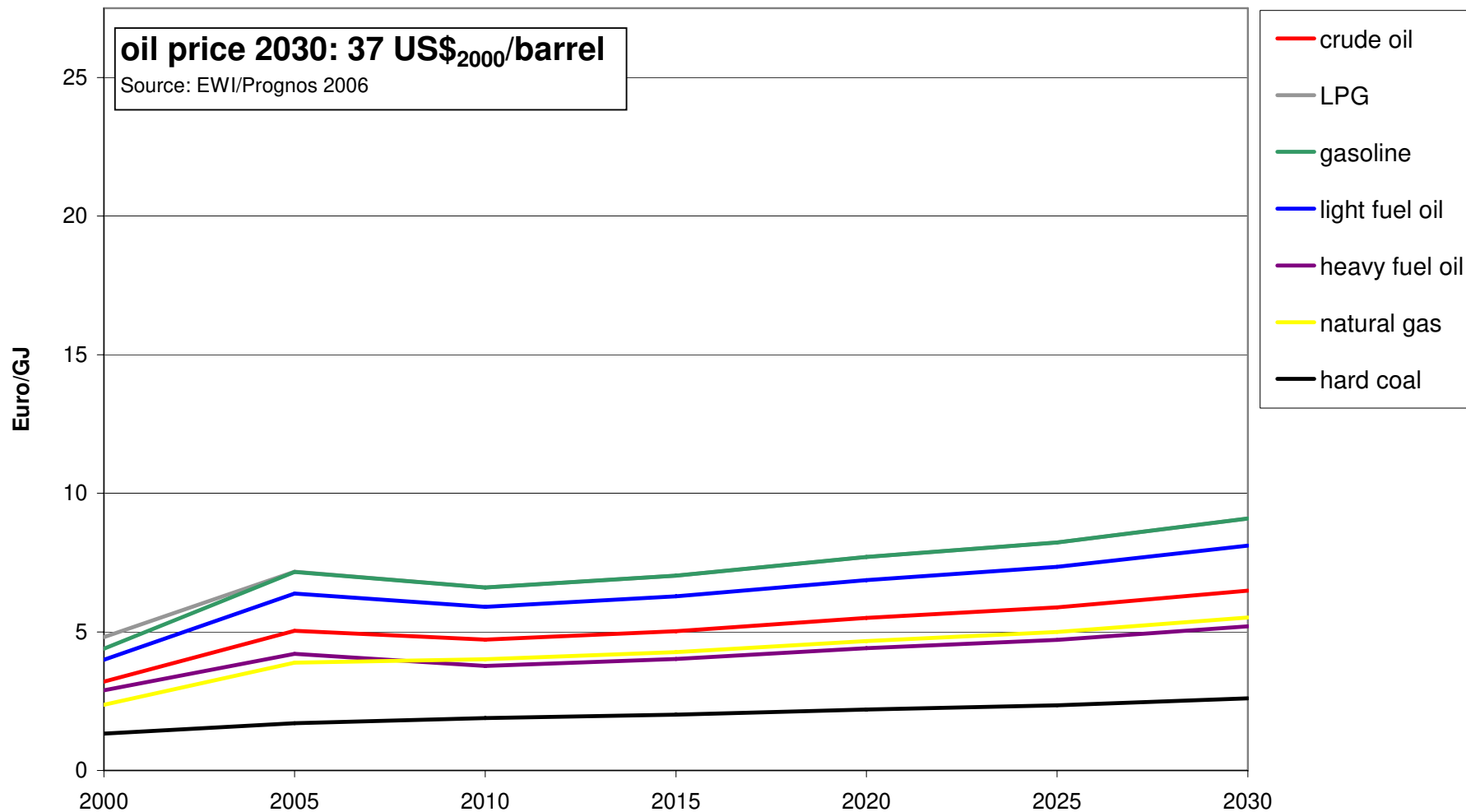



# Energy Price Scenarios

## High Price Scenario

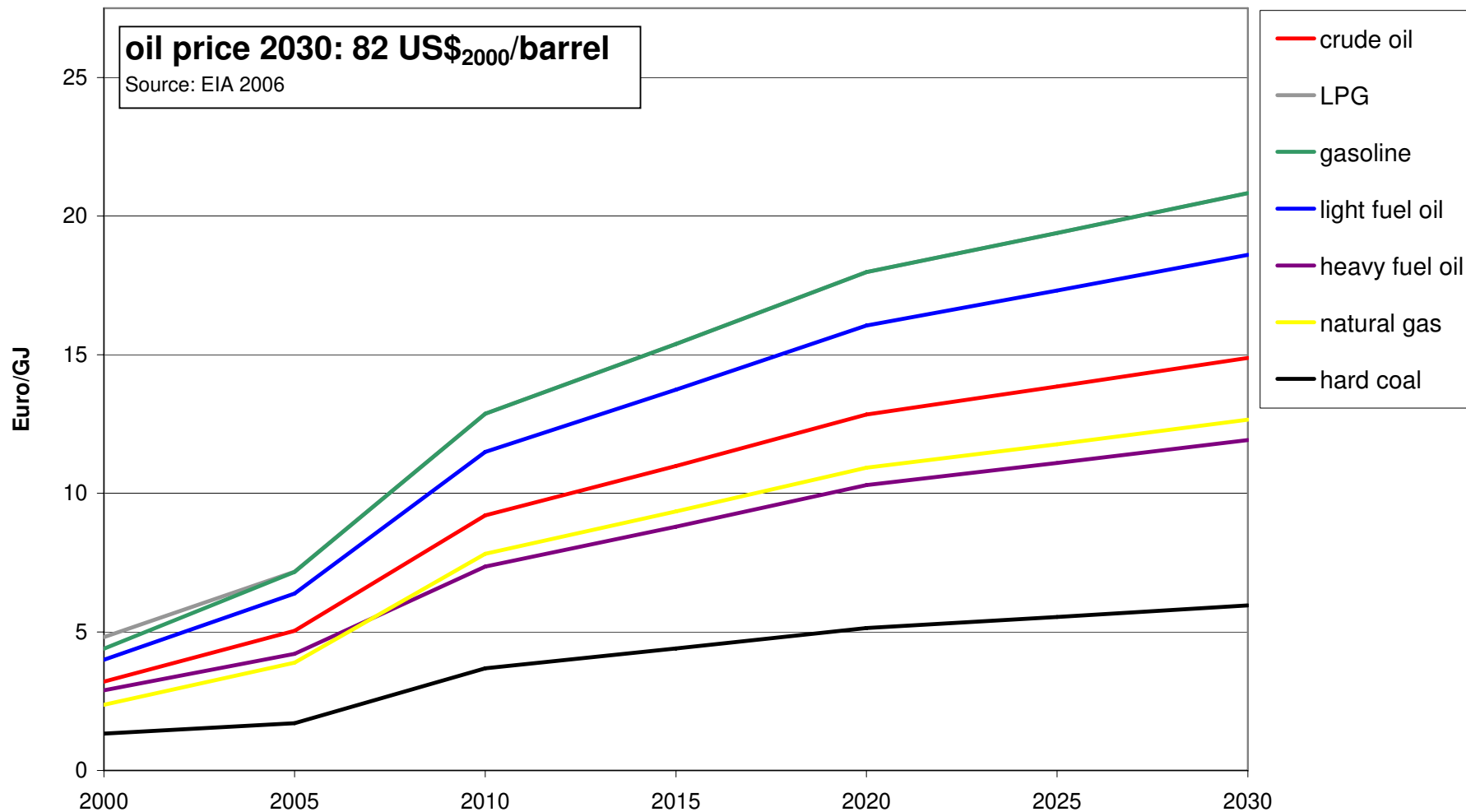

# Energy Price Scenarios

## Price Spike Scenario

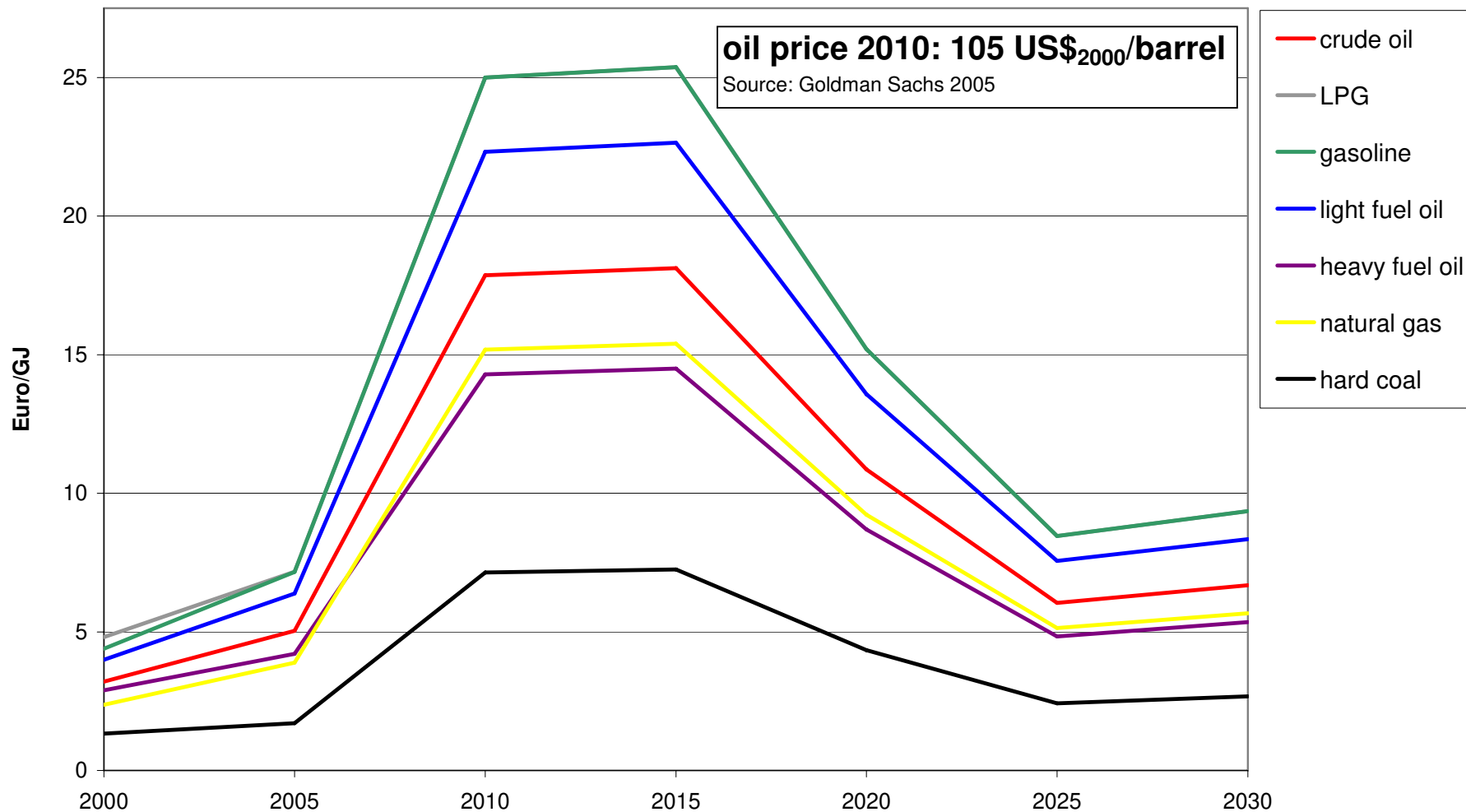

# Analysis

- Energy Systems Model (IKARUS-LP):
  - consistent scenarios
  - impacts on whole energy system (supply and end-use sectors)
- Electricity Sector Model (ELIAS):
  - detailed analysis of electricity generation
  - interaction with carbon emissions trading

# IKARUS-LP Model Structure

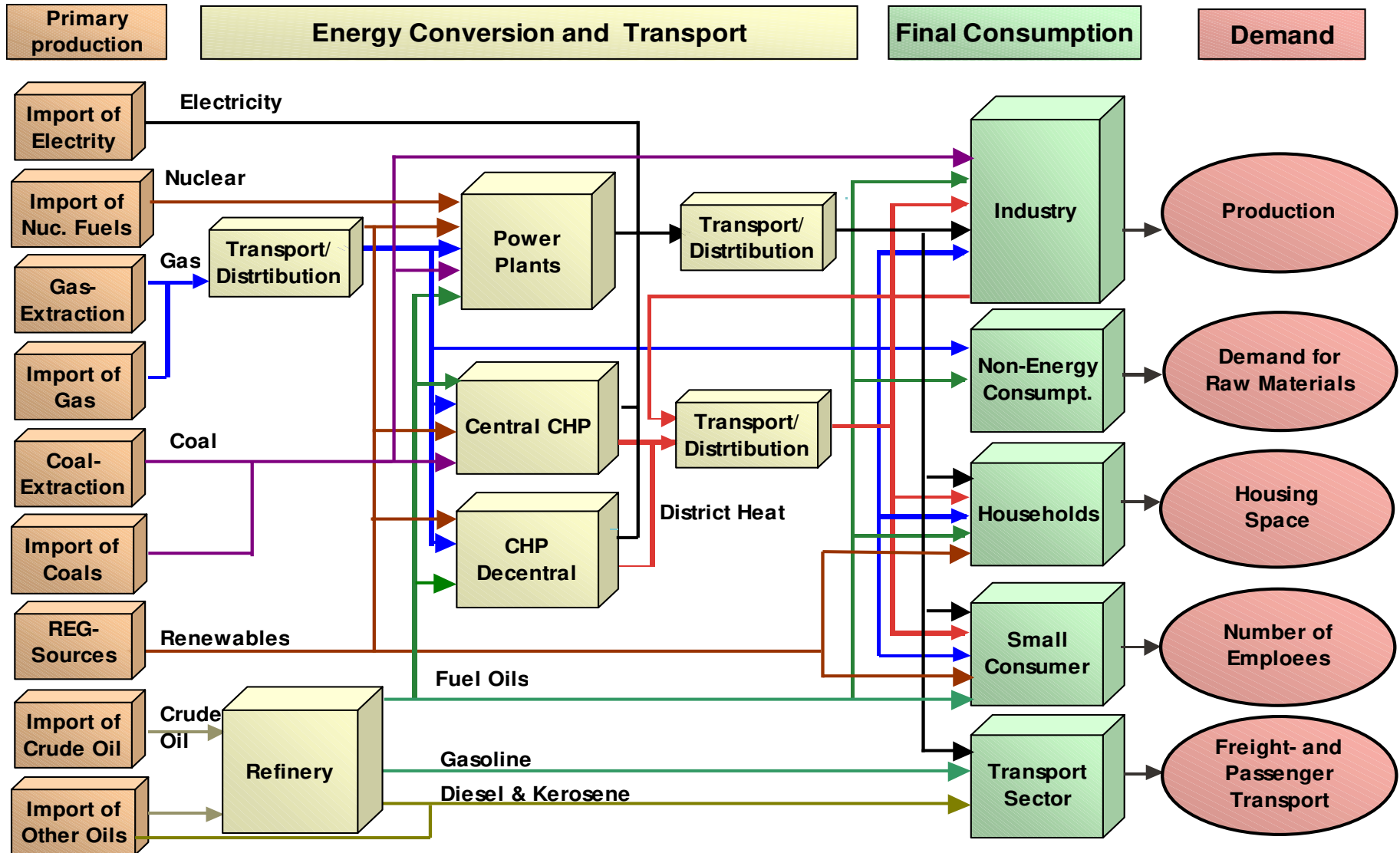

# Modeling Approach

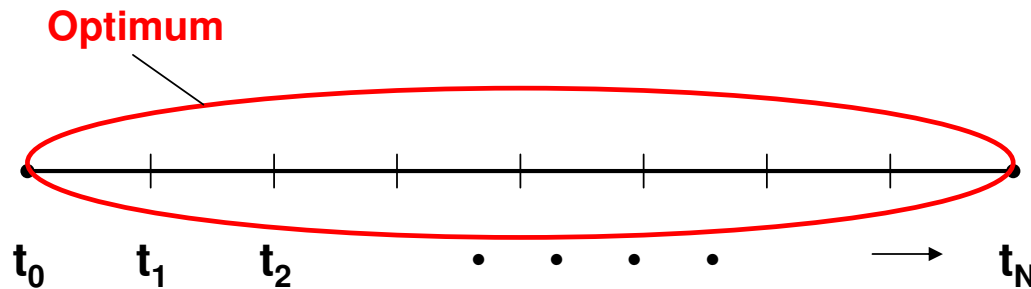

Perfect-Foresight

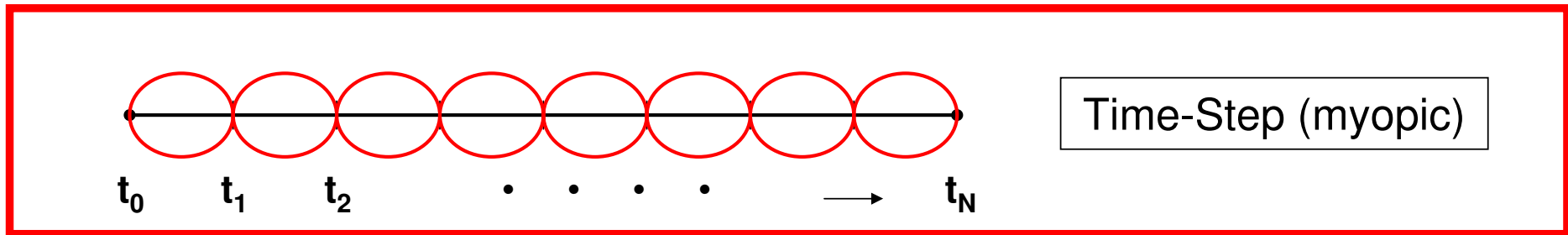

Time-Step (myopic)

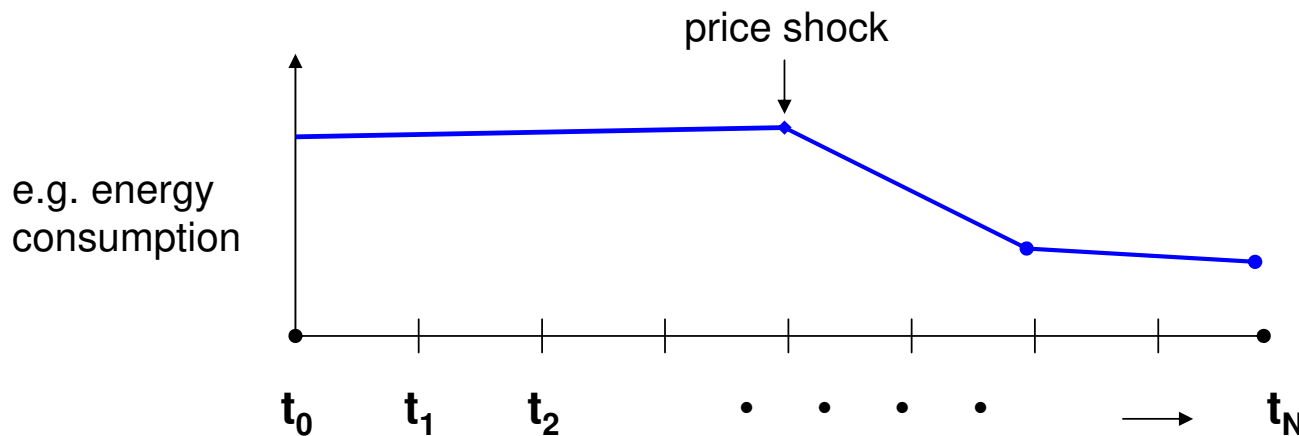

# Total Primary Energy Supply

Reference Scenario

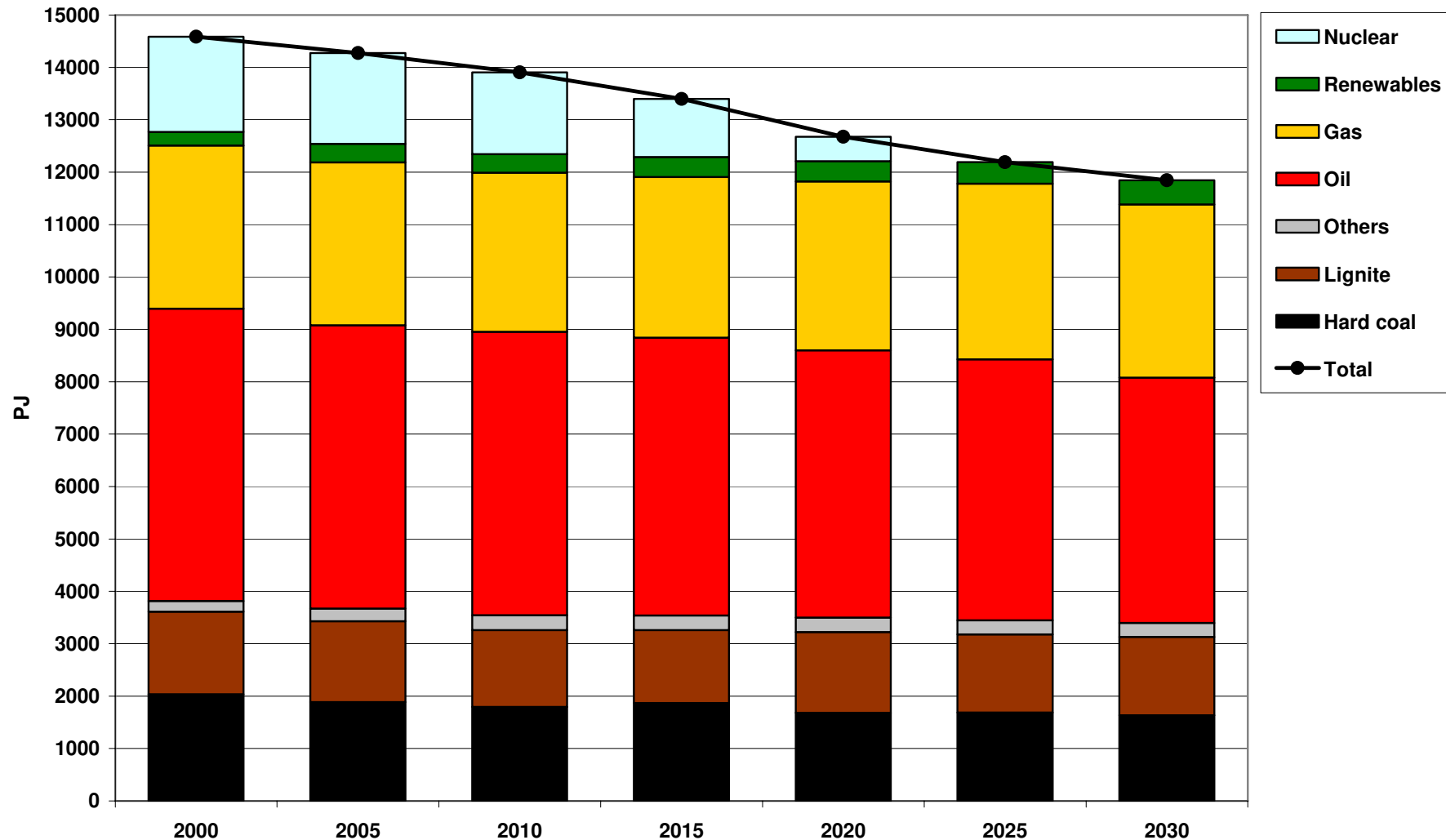



# Total Primary Energy Supply

High Price Scenario

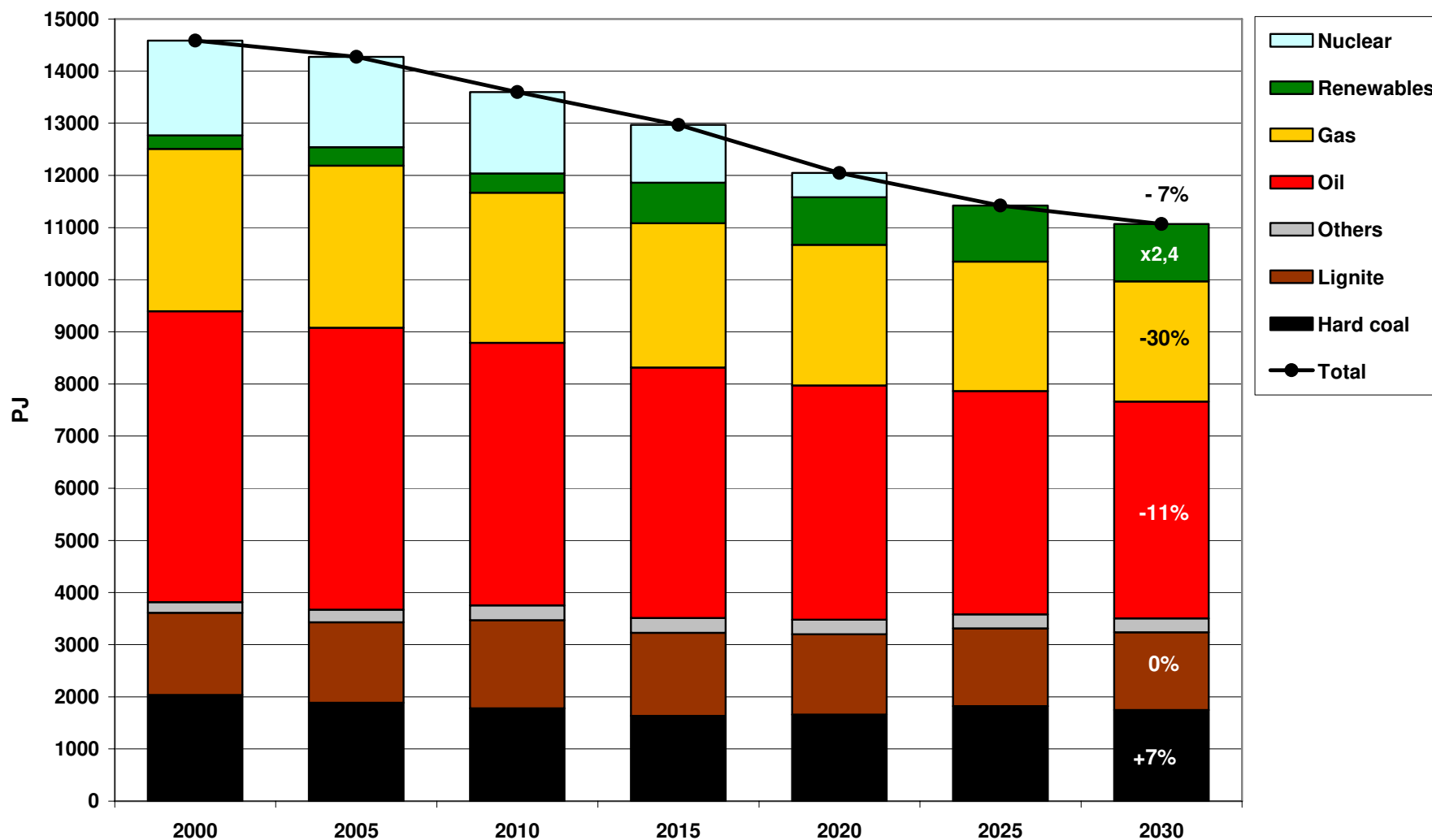

# Total Primary Energy Supply

Price Spike Scenario

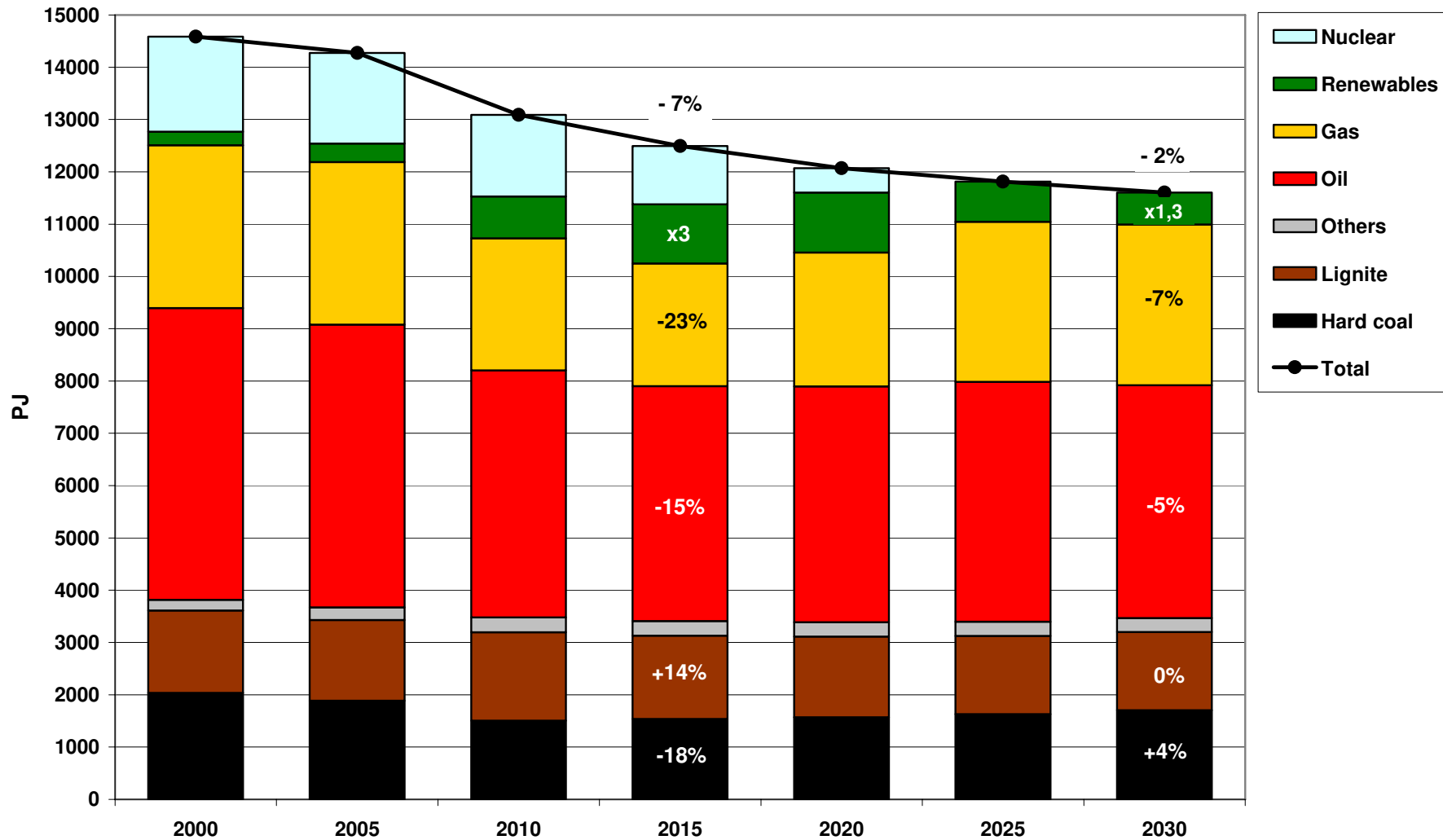

# CO<sub>2</sub>-Emissions

Reference Scenario

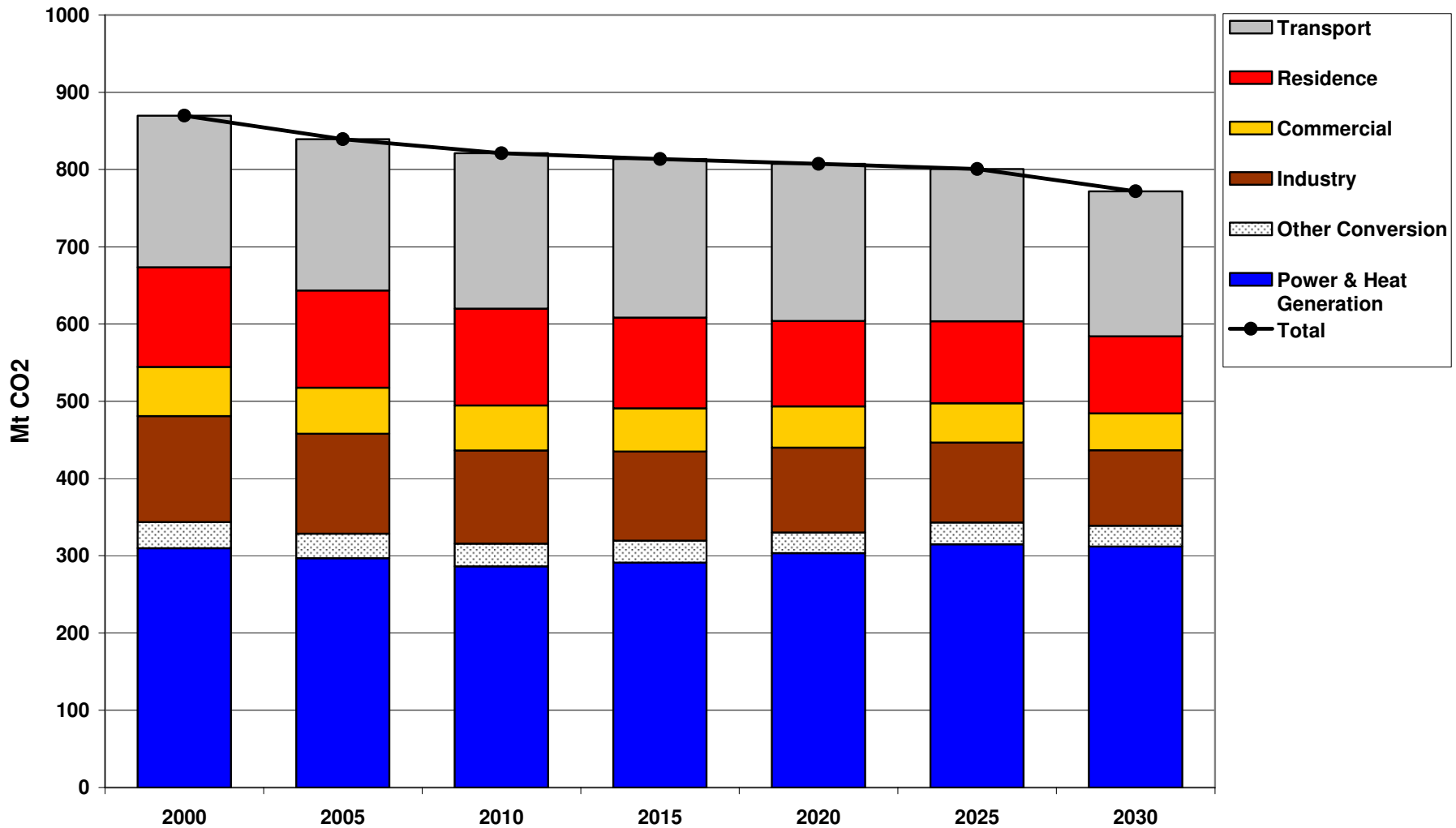

# CO<sub>2</sub>-Emissions

High Price Scenario

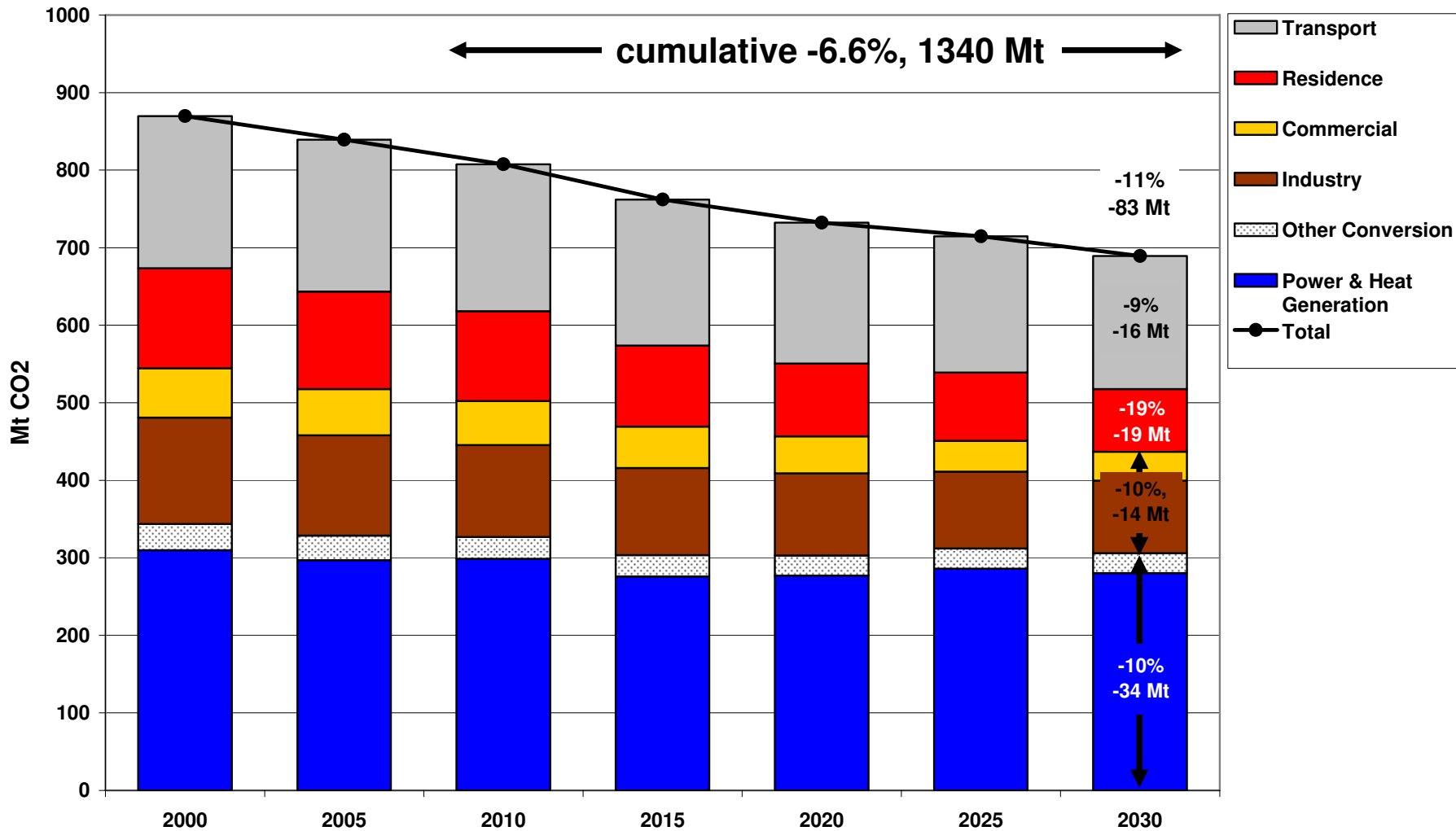

# CO<sub>2</sub>-Emissions

Price Spike Scenario

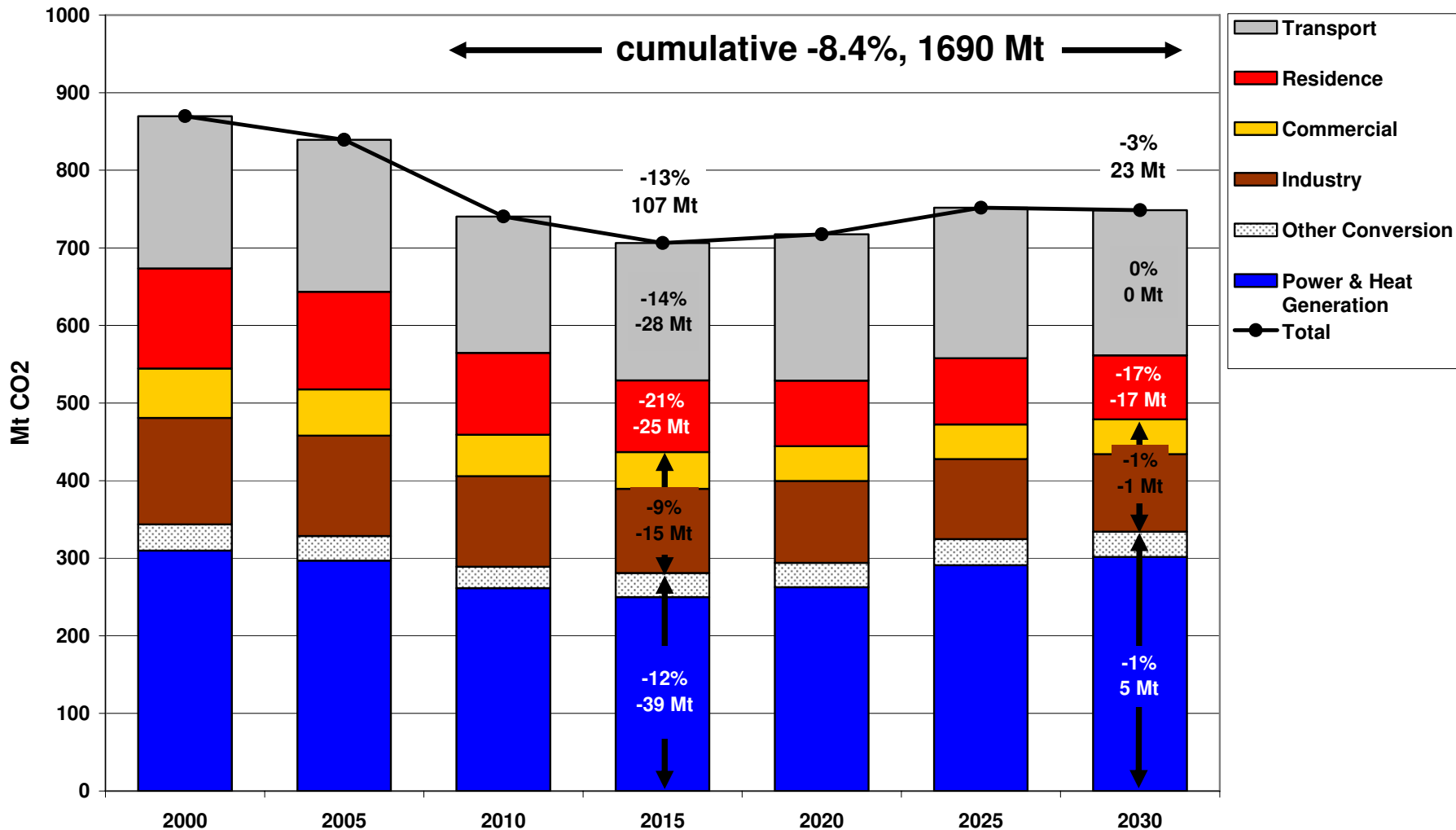

# Final Energy Consumption

Reference Scenario

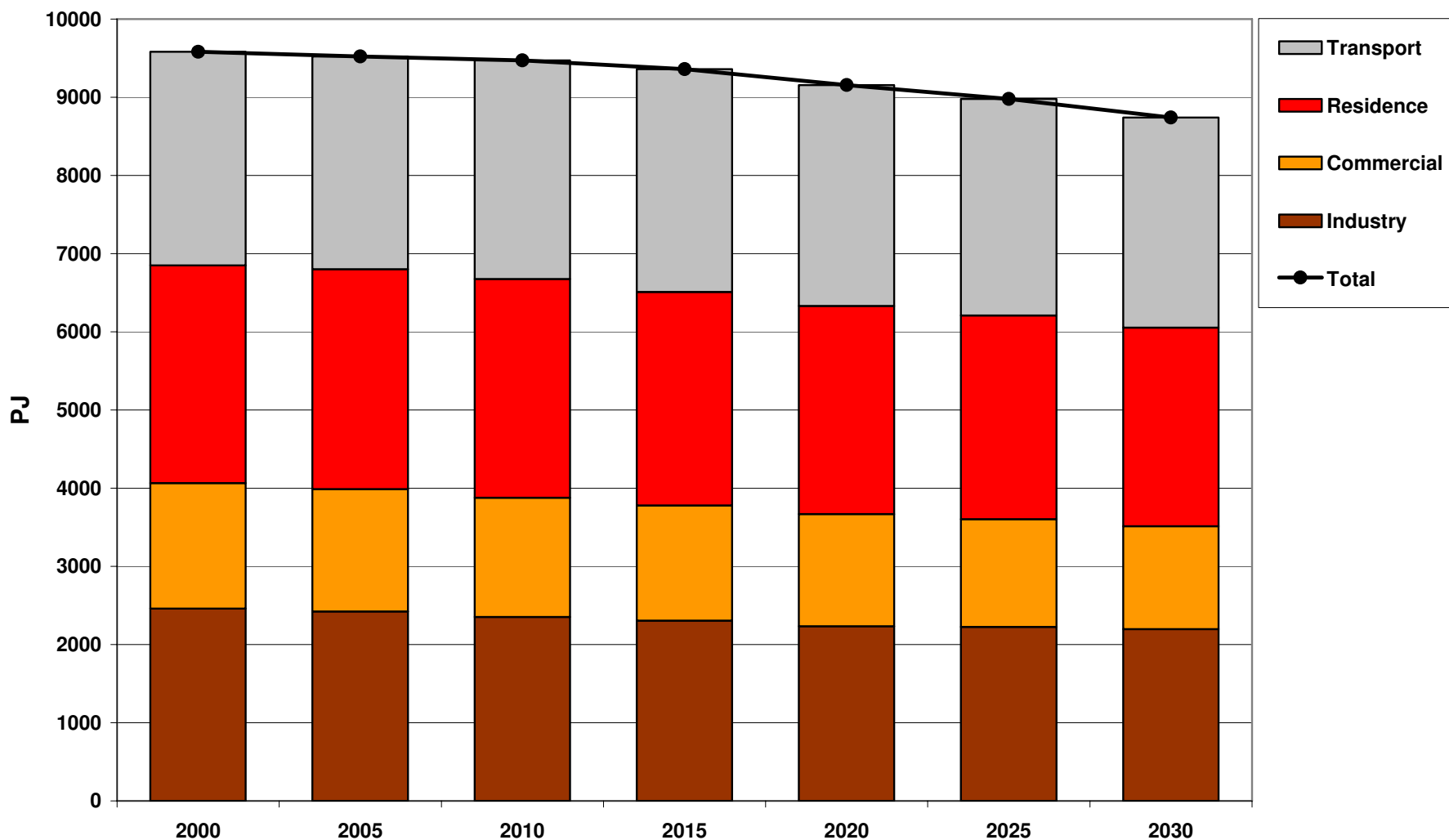

# Final Energy Consumption

High Price Scenario

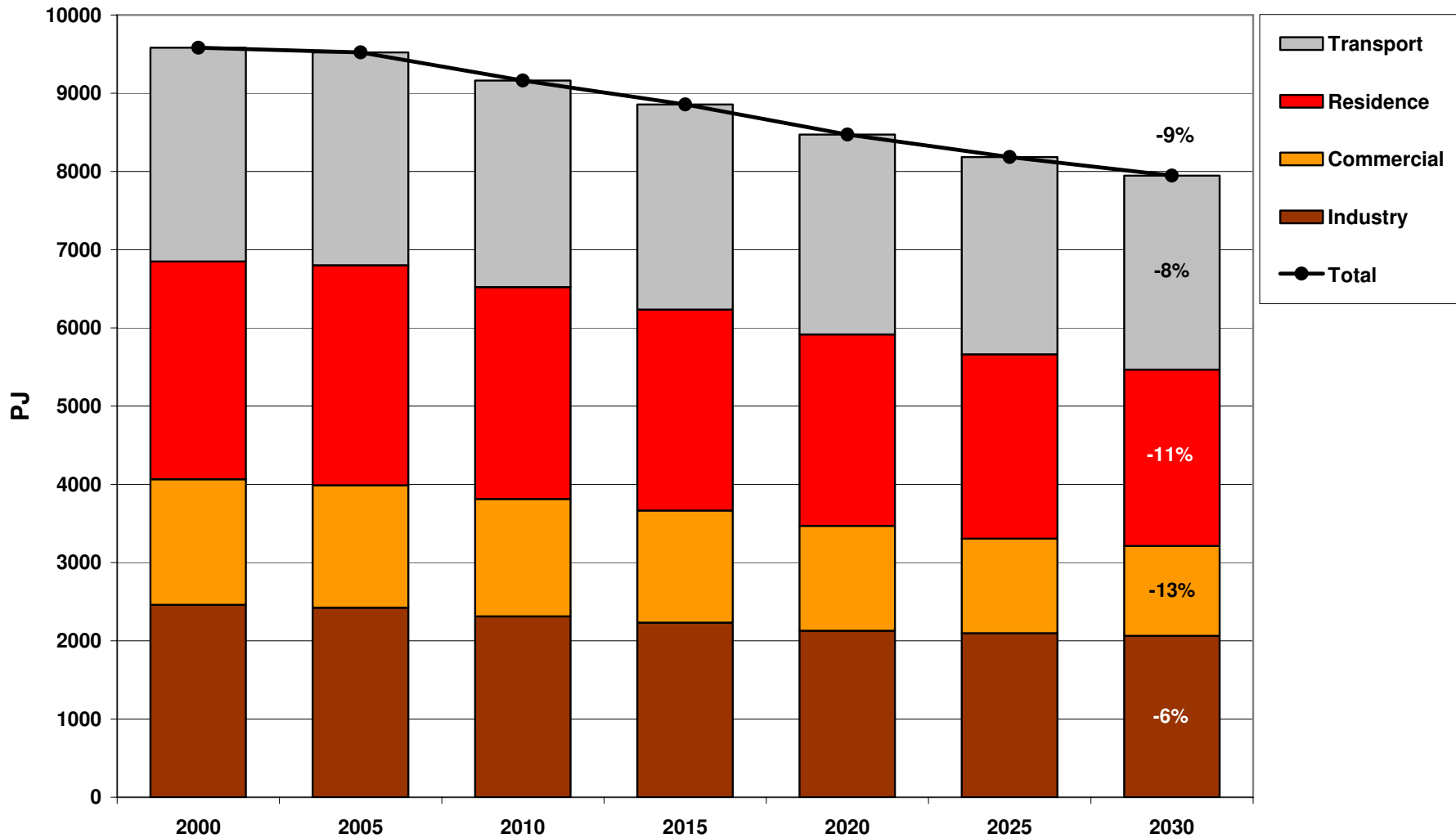

# Final Energy Consumption

Price Spike Scenario

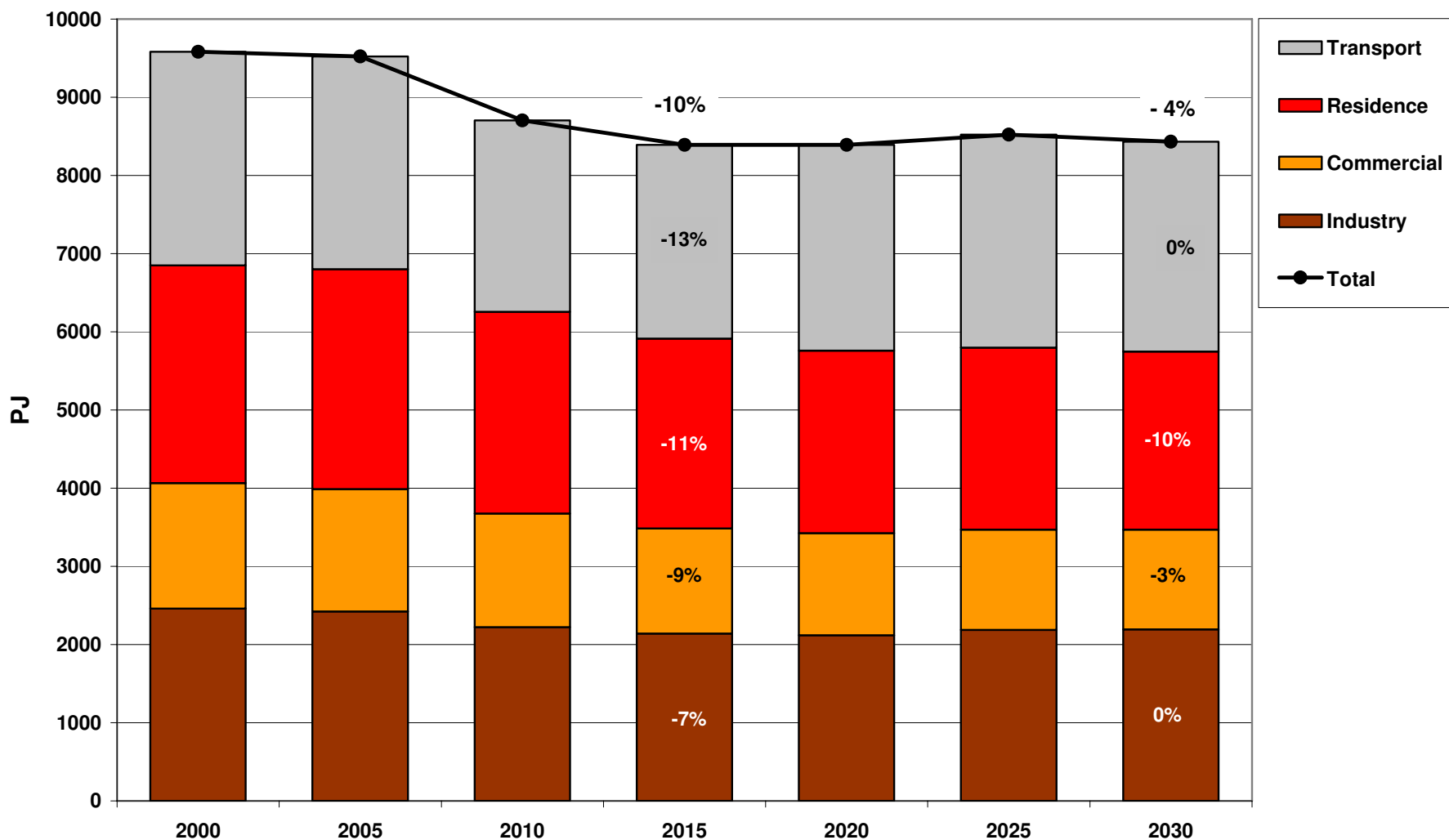



# ELIAS Model Approach

- investments in power generation sector
- utility perspective
- political instruments:
  - taxes
  - feed-in-tariffs for renewables (EEG)
  - promotion of CHP (KWKG)
  - emissions trading scheme/allocation rules

# ELIAS Model Approach

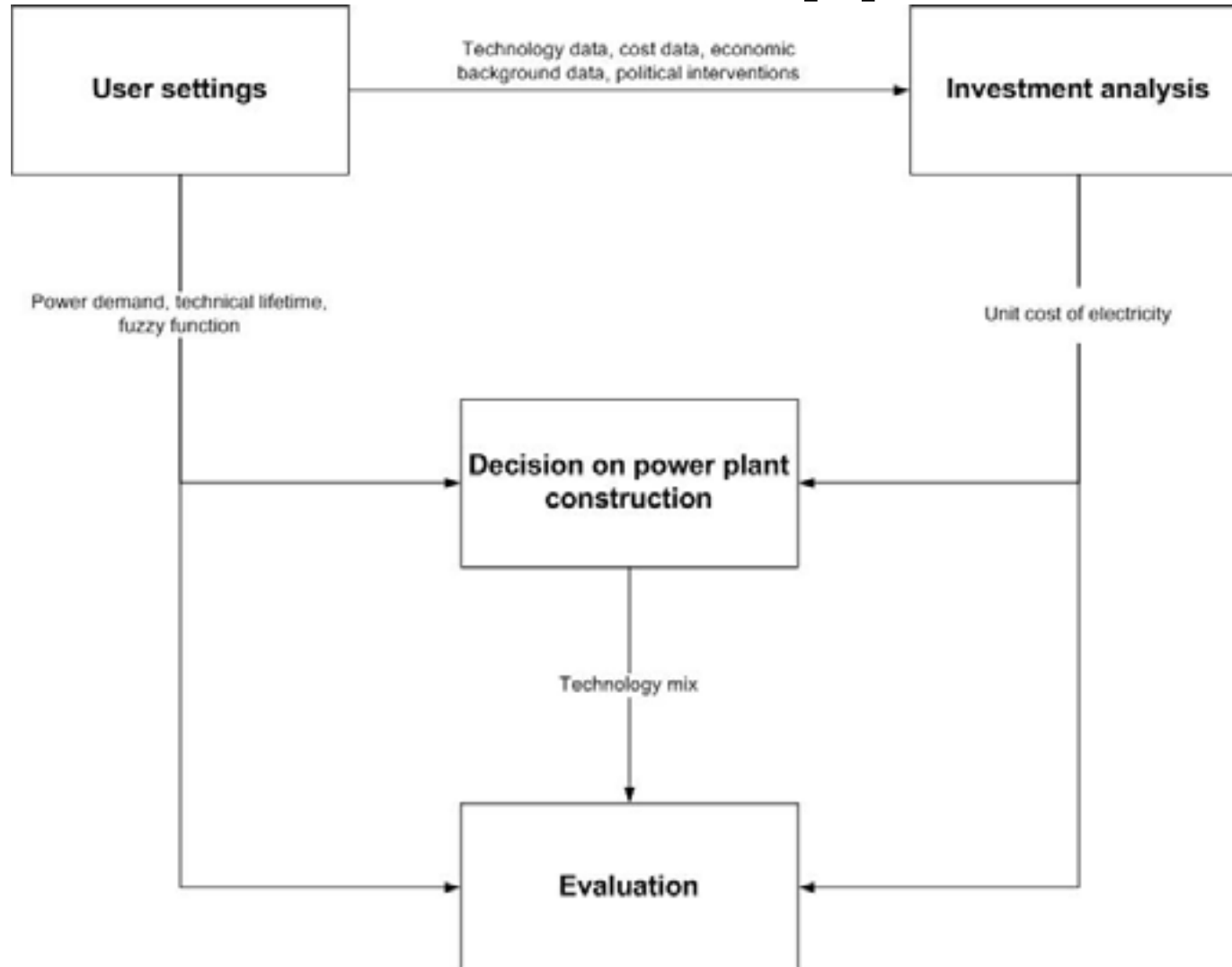

# Electricity Sector – Current Allocation

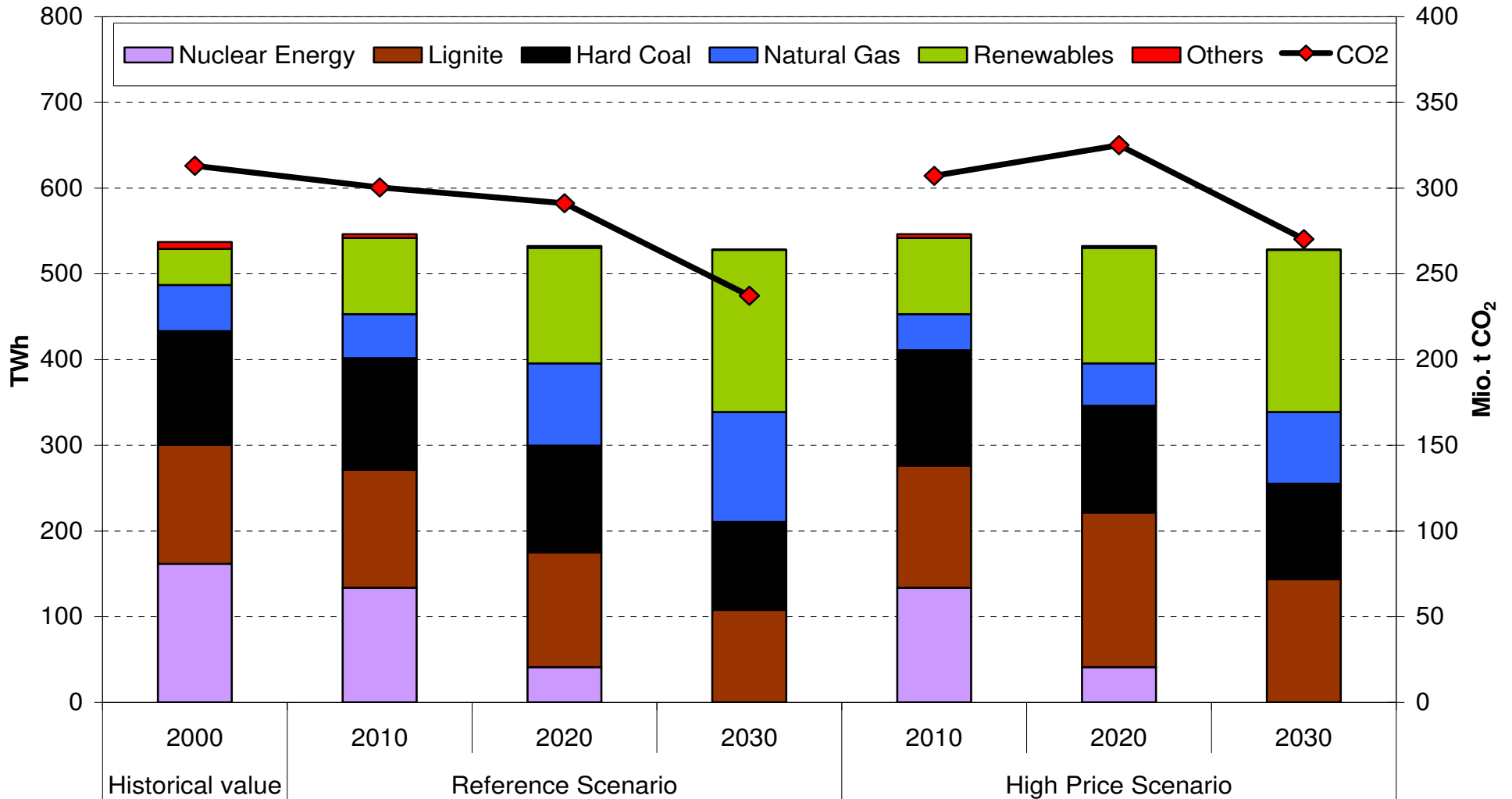

# Electricity Sector – Full Auctioning

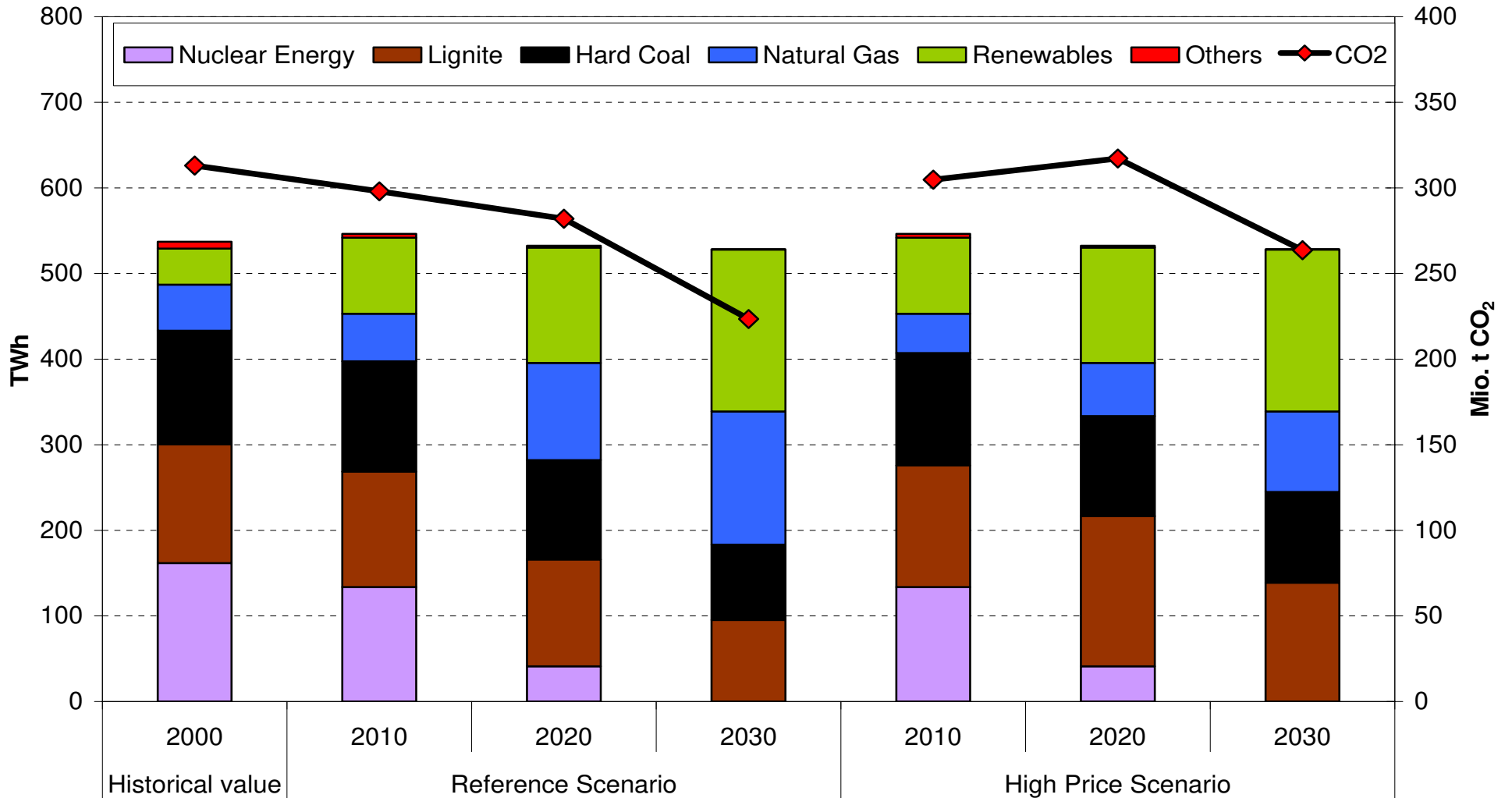

# Conclusions

- energy-savings in end-use sectors  
but: relaxation effects in some sectors
- increased utilization of renewables
- electricity generation: natural gas vs. coal  
(strongly dependent on energy price levels  
and allocation rules)
- domestic hard coal competitive  
coal-to-liquids: > 55 US\$/barrel



Thank You!

# Polygeneration

**Thomas Rostrup-Nielsen**

**HALDOR TOPSOE A/S**

Haldor Topsøe A/S - Risø – May 23 2007



# Outline

- **IGCC and Polygeneration**
- **TIGAS – Topsoe's Integrated Gasoline Synthesis**
- **Integration of IGCC & TIGAS**
  - Process performance
  - Economics
  - Options for CO<sub>2</sub> abatement





- **IGCC and Polygeneration**
- **TIGAS – Topsoe's Integrated Gasoline Synthesis**
- **Integration of IGCC & TIGAS**
  - Process performance
  - Economics
  - Options for CO<sub>2</sub> abatement





# Inflation Adjusted Monthly CRUDE OIL PRICES (1946- Present)

In May 2006 Dollars

© www.InflationData.com

Updated 7/18/06

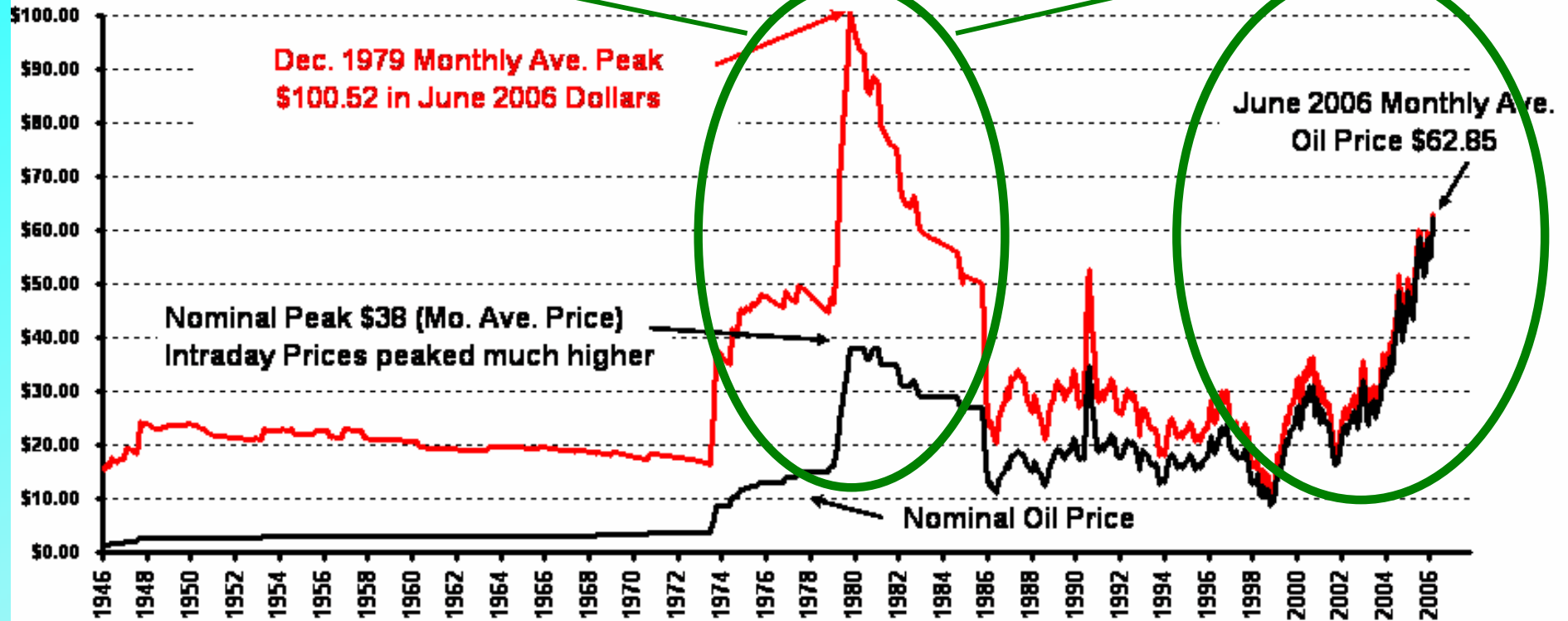

Nominal Monthly Ave. Oil Price

Inflation Adjusted Monthly Average Oil Price

Source of Data:

Illinois Basin Crude Prices- [www.ioga.com/Special/crudeoil\\_Hist.htm](http://www.ioga.com/Special/crudeoil_Hist.htm)

CPI-U Inflation index- [www.bls.gov](http://www.bls.gov)



# Coal as a Raw Material

- **High oil prices & Security of supply**
- **Interesting to generate power from coal**
  - if capable of dealing with CO<sub>2</sub>
- **Interesting to generate chemicals otherwise obtained from oil from coal**
  - E.g. transportations fuels
- **Interesting to use technology which can utilize renewable energy sources**
  - E.g. biomass



# IGCC Plant

Dirty synthesis gas  
 $\text{CO} + \text{H}_2 + \text{CO}_2$

Clean synthesis gas  
 $\text{CO} + \text{H}_2 + \text{CO}_2$   
Ideal for chemicals production

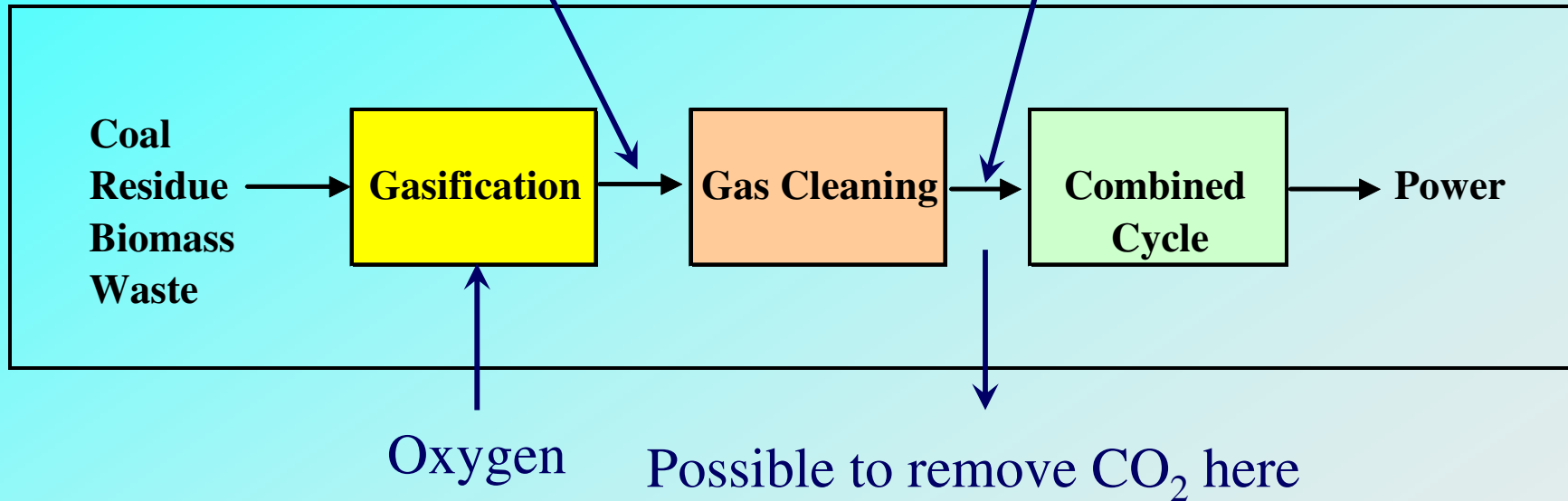

# IGCC & Chemicals Production Polygeneration

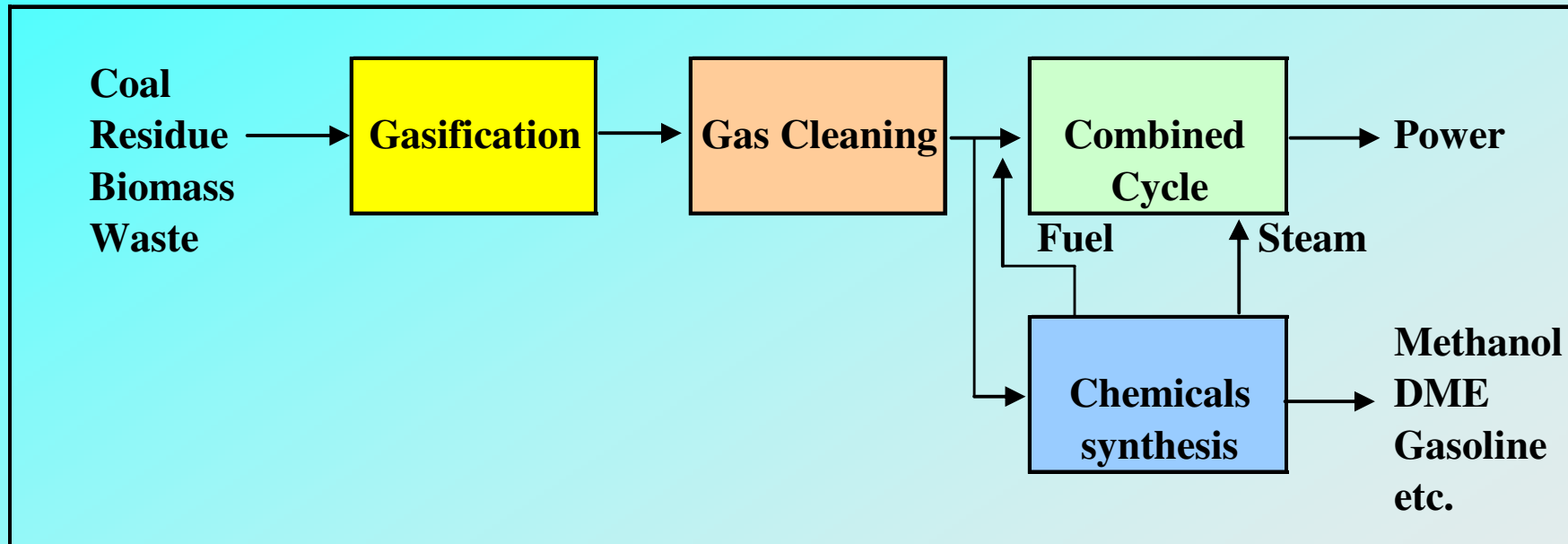

- **IGCC and Polygeneration**
- **TIGAS – Topsoe's Integrated Gasoline Synthesis**
- **Integration of IGCC & TIGAS**
  - Process performance
  - Economics
  - Options for CO2 abatement





# Worlds first Gas to Gasoline Plant – New Zealand – 1986

Gasoline synthesis

MeOH synthesis

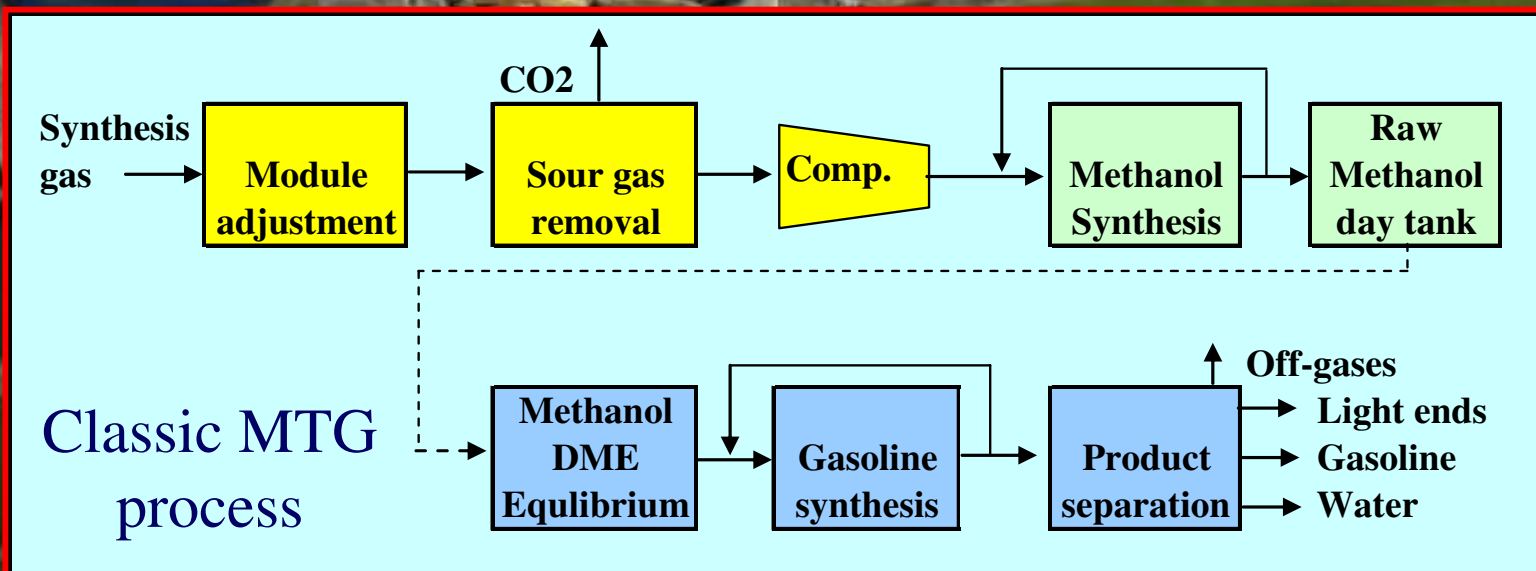

# TIGAS Process

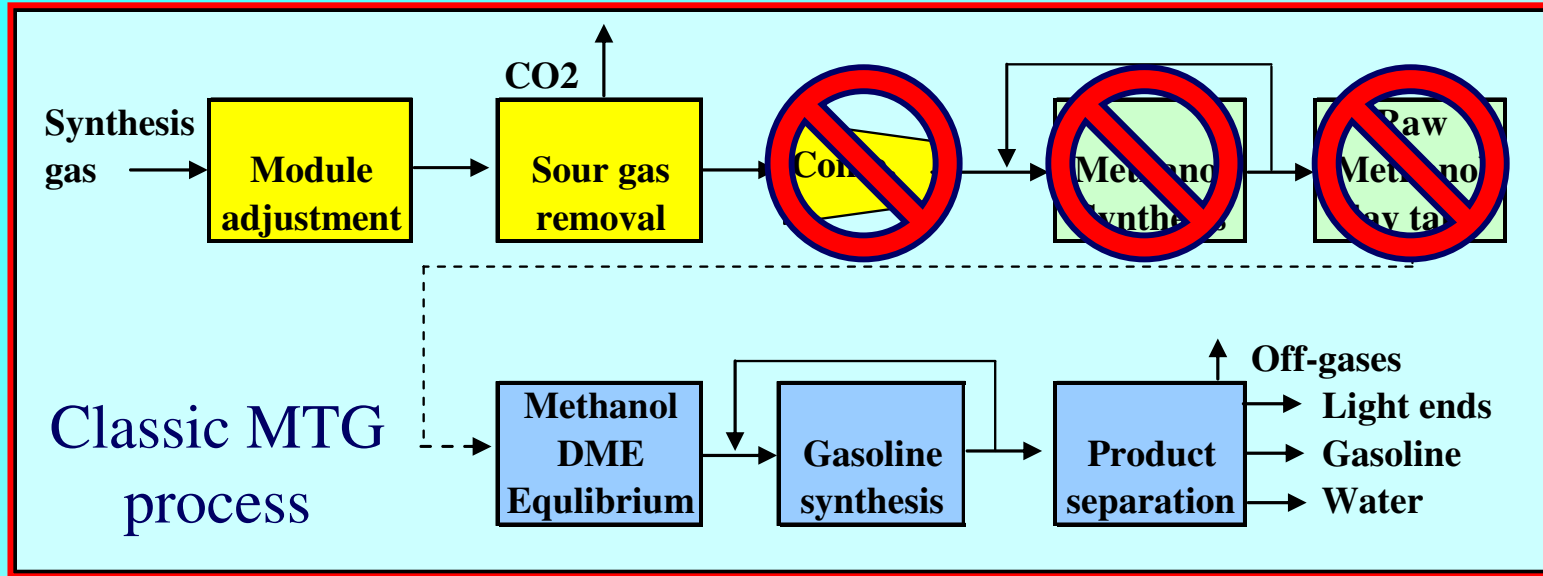

## TIGAS Process

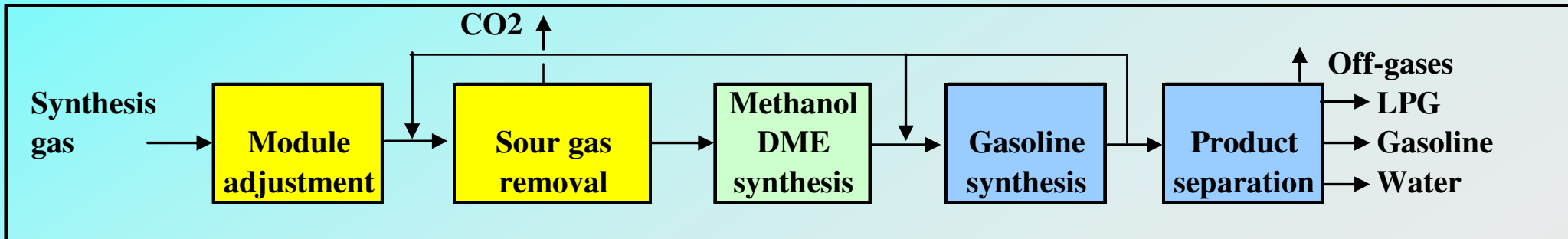



# 1980's Demonstrations from Natural Gas

Houston – 1 ton/day



Frederikssund – few kg/day



- **IGCC and Polygeneration**
- **TIGAS – Topsoe's Integrated Gasoline Synthesis**
- **Integration of IGCC & TIGAS**
  - **Process performance**
  - **Economics**
  - **Options for CO<sub>2</sub> abatement**



# IGCC & TIGAS

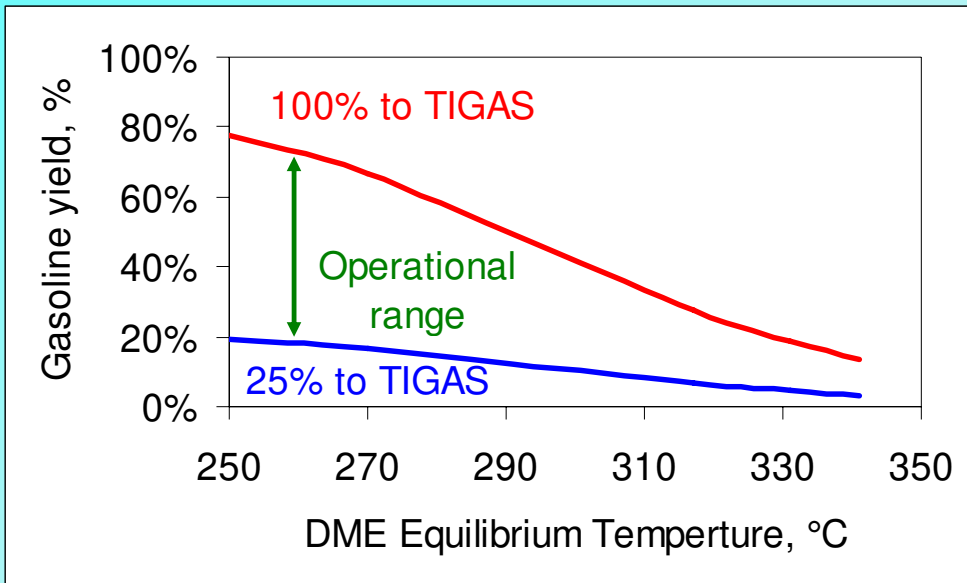
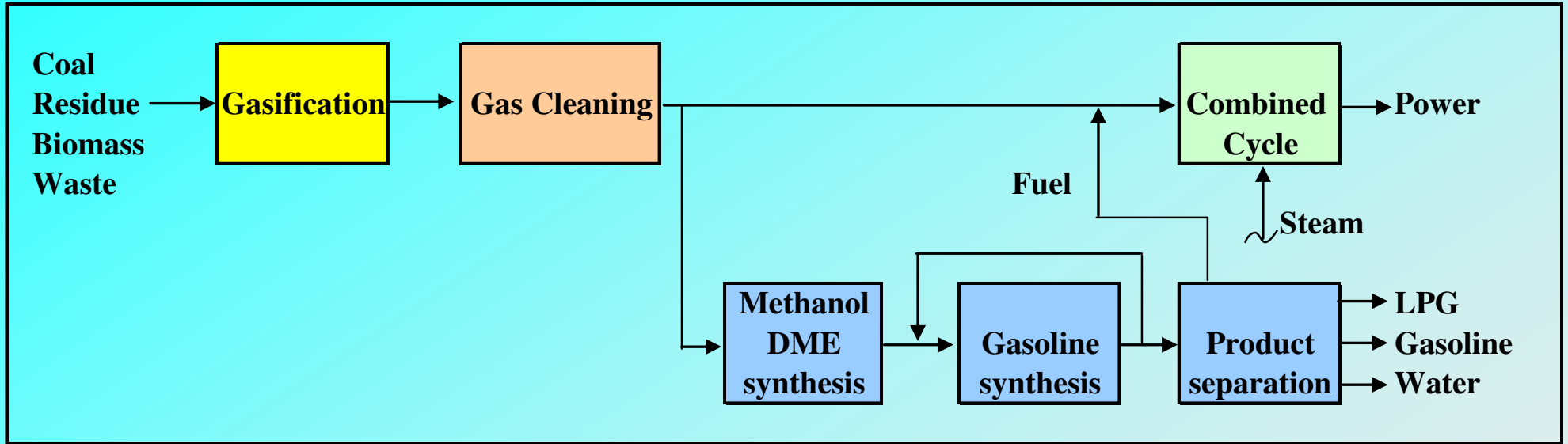

		IGCC	I4	I4
Gas feed to TIGAS	%		100%	25%
Power	MW	1103	524	957
Gasoline	ton/h	0	60	15
	MW	0	723	181
LPG	MW	0	105	26
Total	MW	1103	1352	1164



# Efficiency

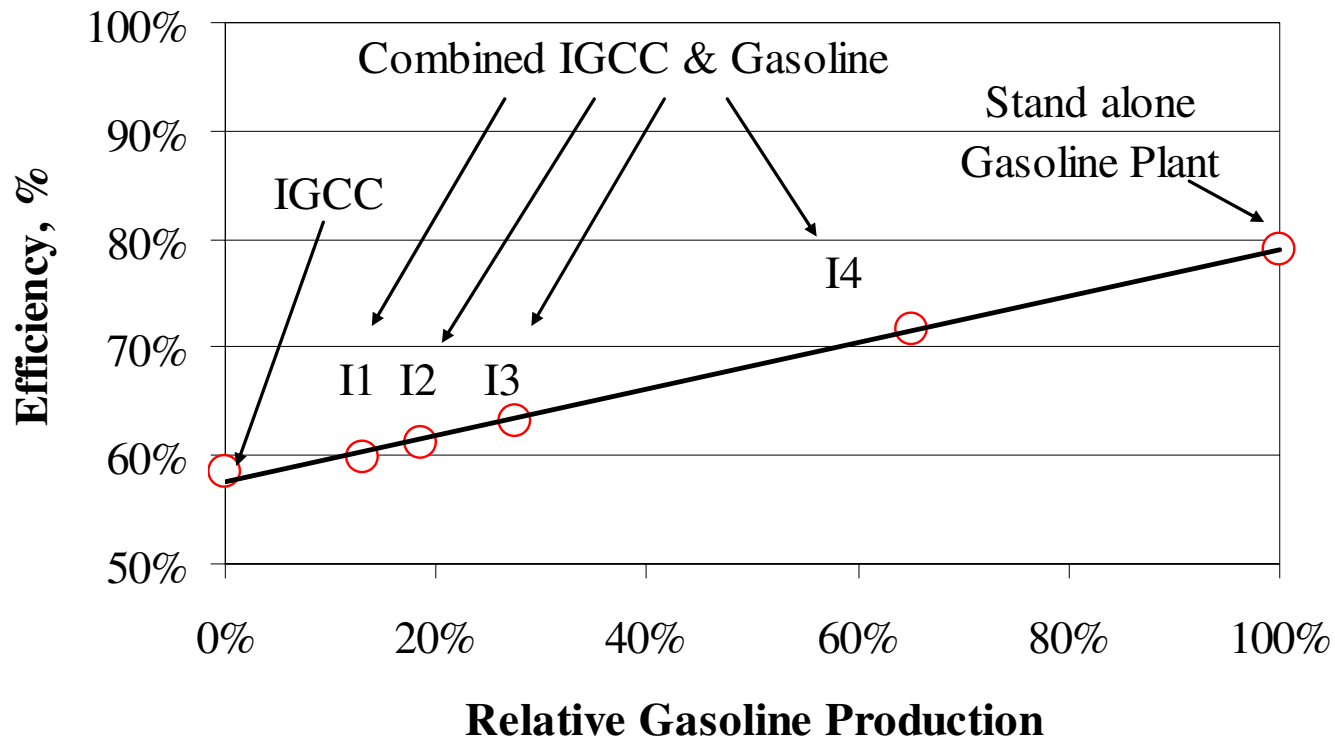
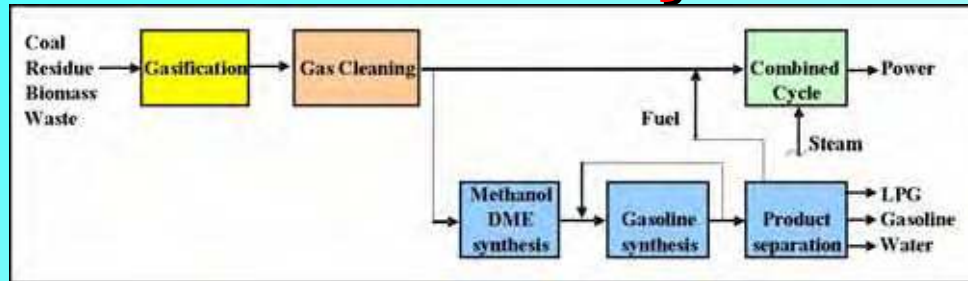

# Economics

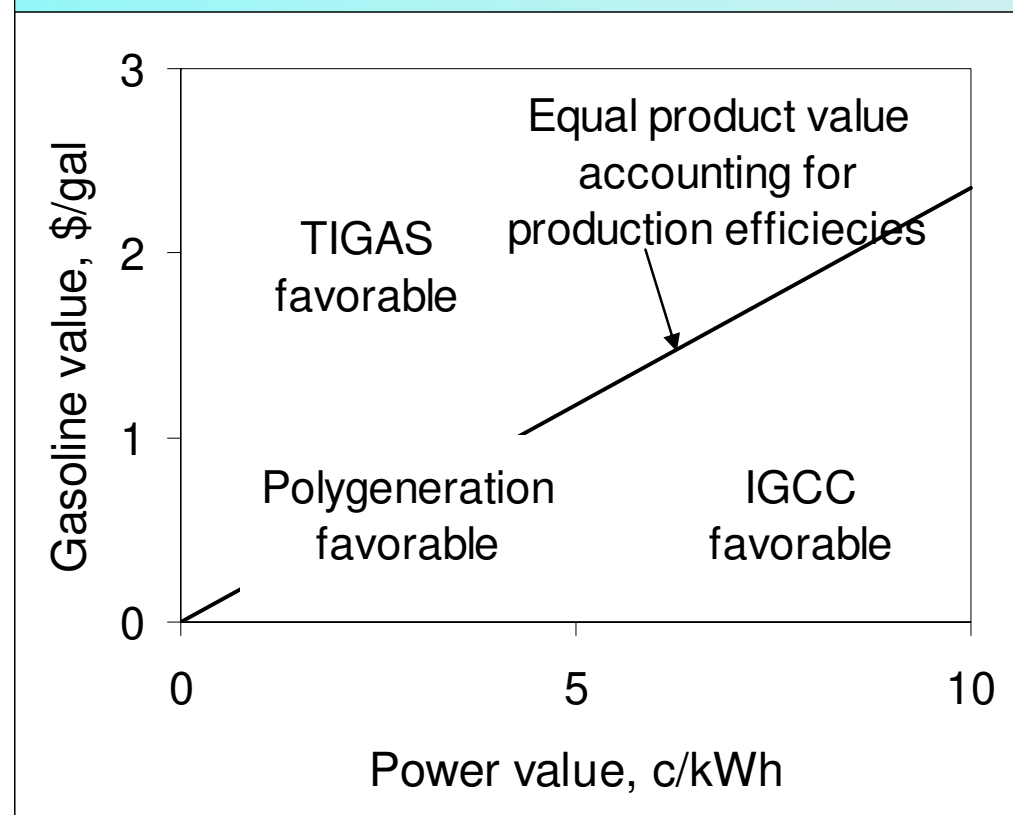
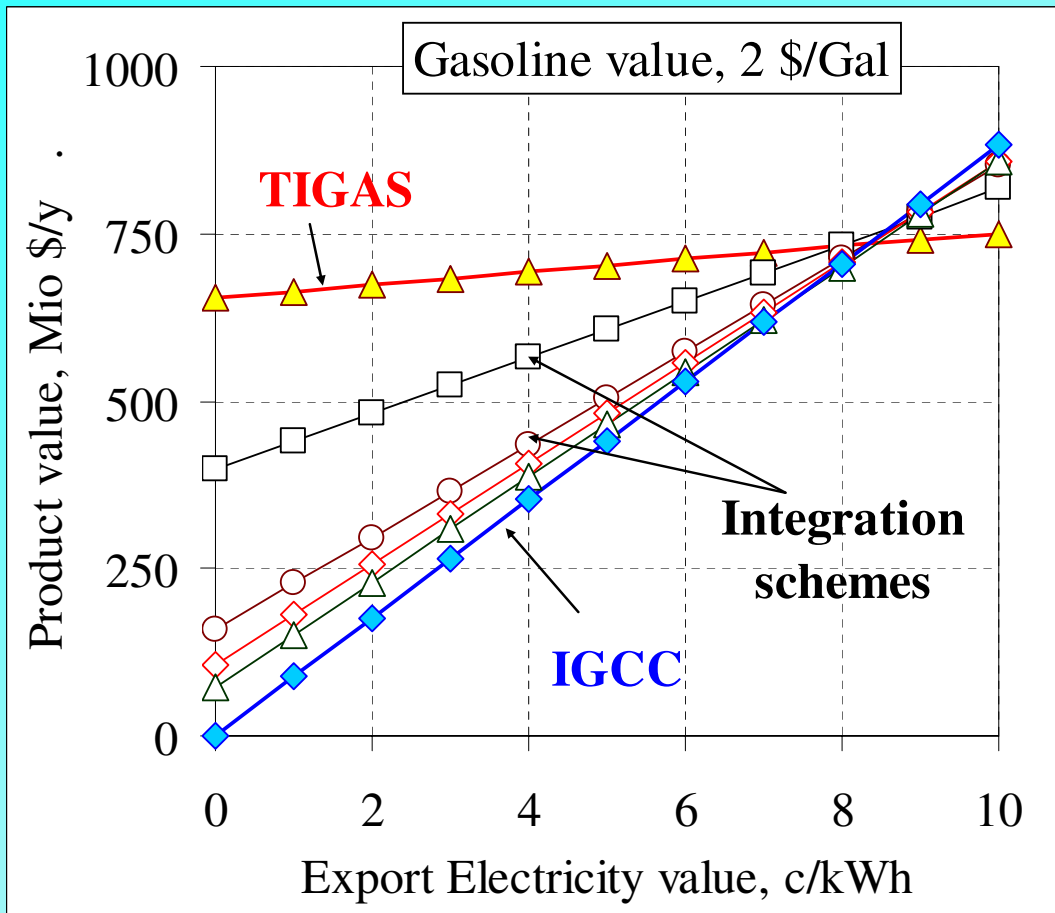
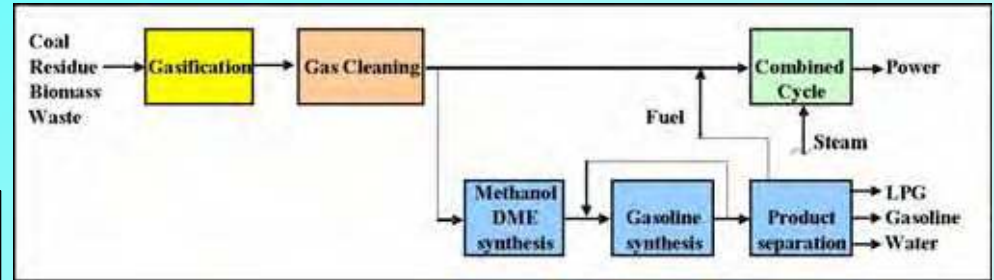

# How good an Investment ?

Assumed investment for TIGAS add-on 10,000 USD/bbl/d

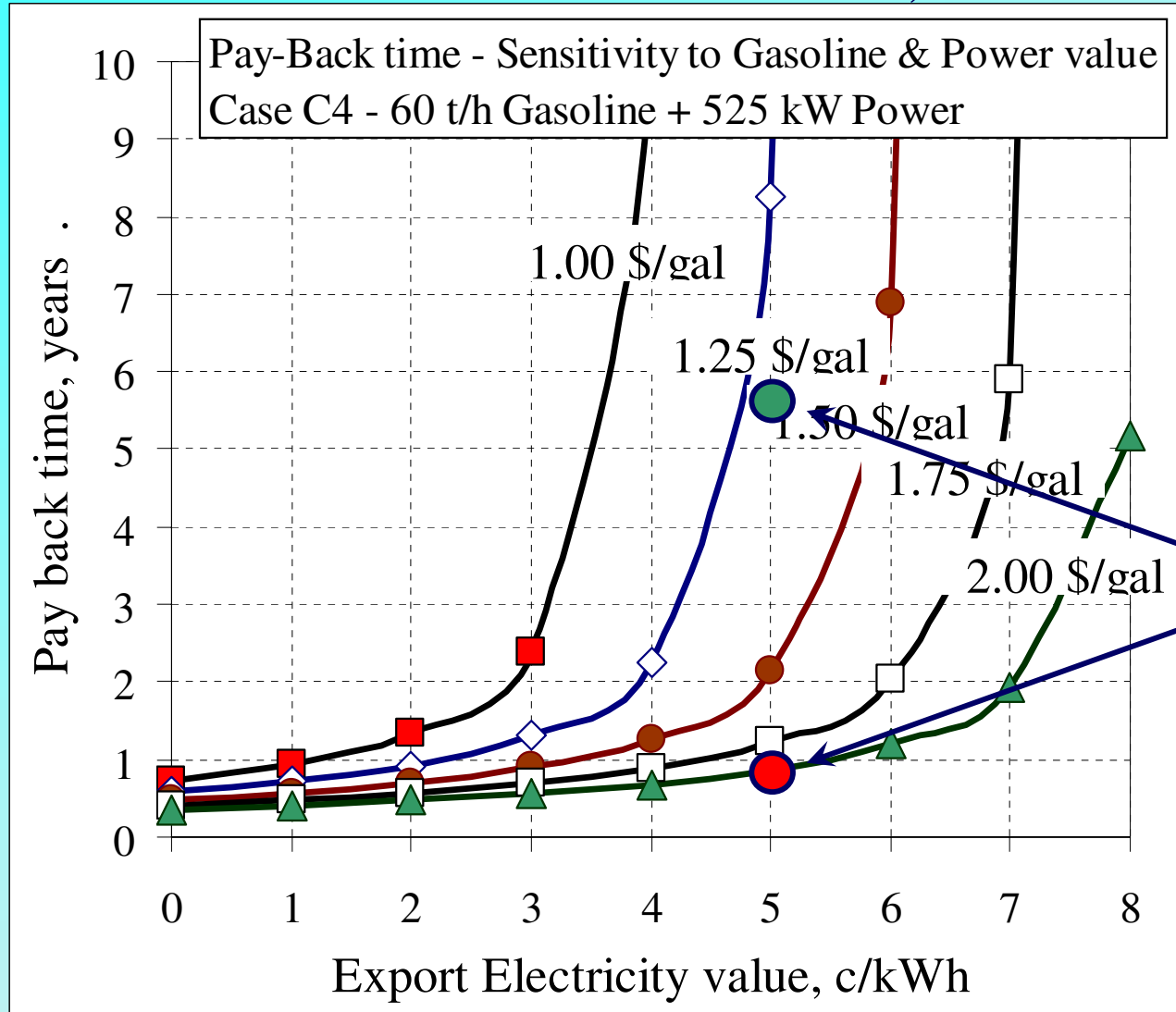

Operational flexibility



# Operational Flexibility

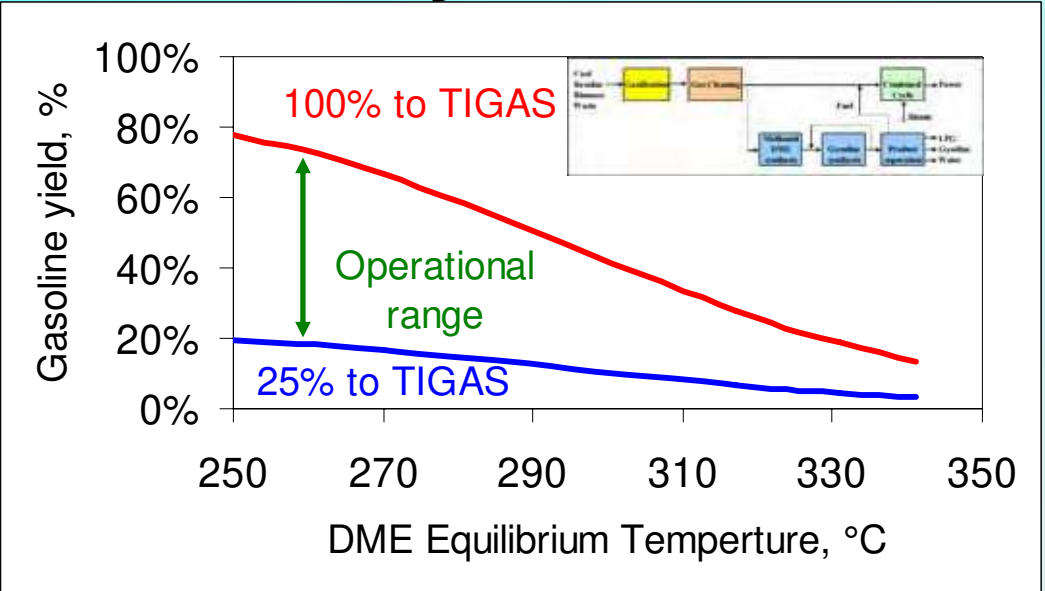
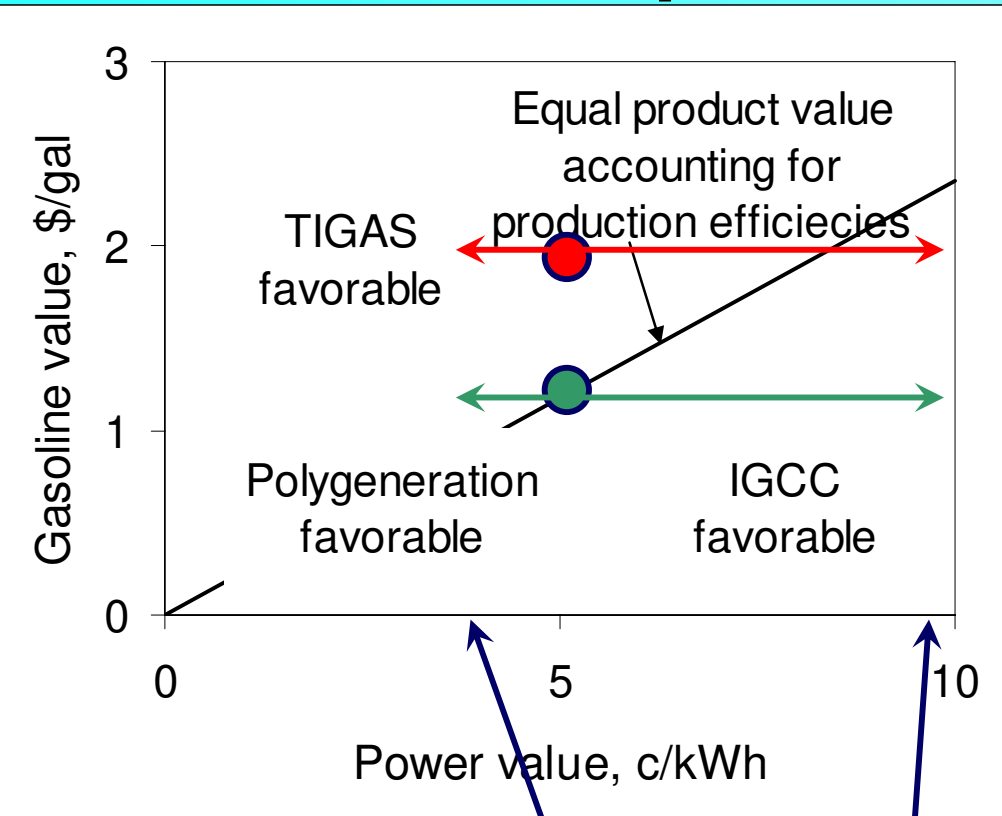

		IGCC	14	14
Gas feed to TIGAS	%		100%	25%
Power	MW	1103	524	957
Gasoline	ton/h	0	60	15

## Pay back time

Gasoline value	\$/gal	1.3	2.0
Max gasoline	years	5,4	0,83
Operational flex.	years	2,5	0,79

		min	average	max
Power value	c/kWh	3,75	5	10
Fraction of time	%	80%	-	20%





# PSO Project

- Project to demonstrate renewable technology for generation of Power and Gasoline
  - HTAS, DONG, Novozymes
  - Gasoline Pilot in connection with existing gasification plant

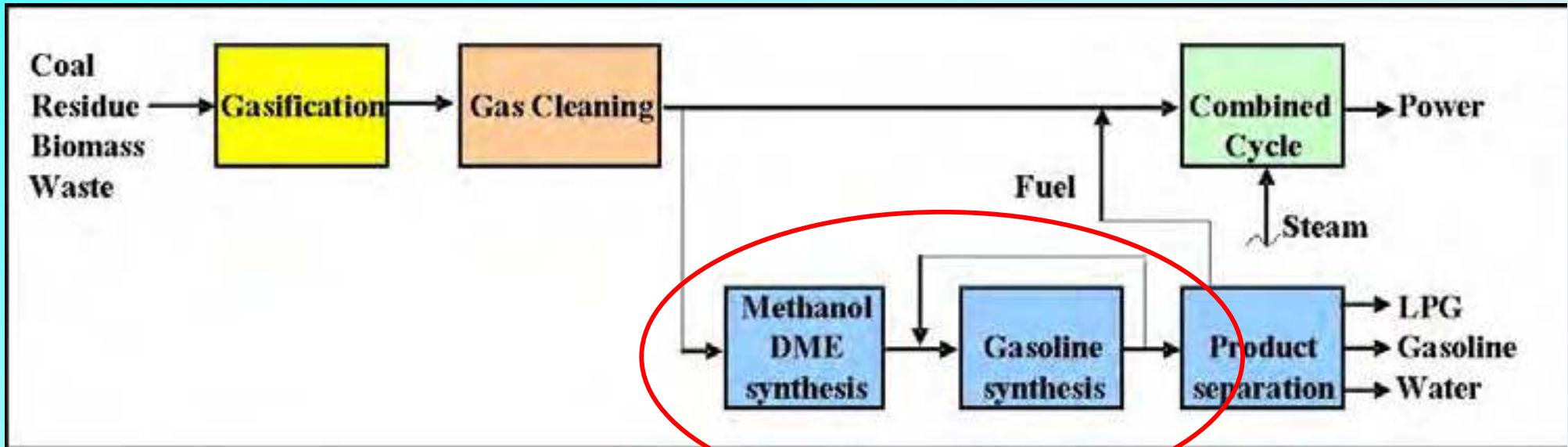



# CO<sub>2</sub> abatement

- Power & Gasoline with CO<sub>2</sub> sequestration

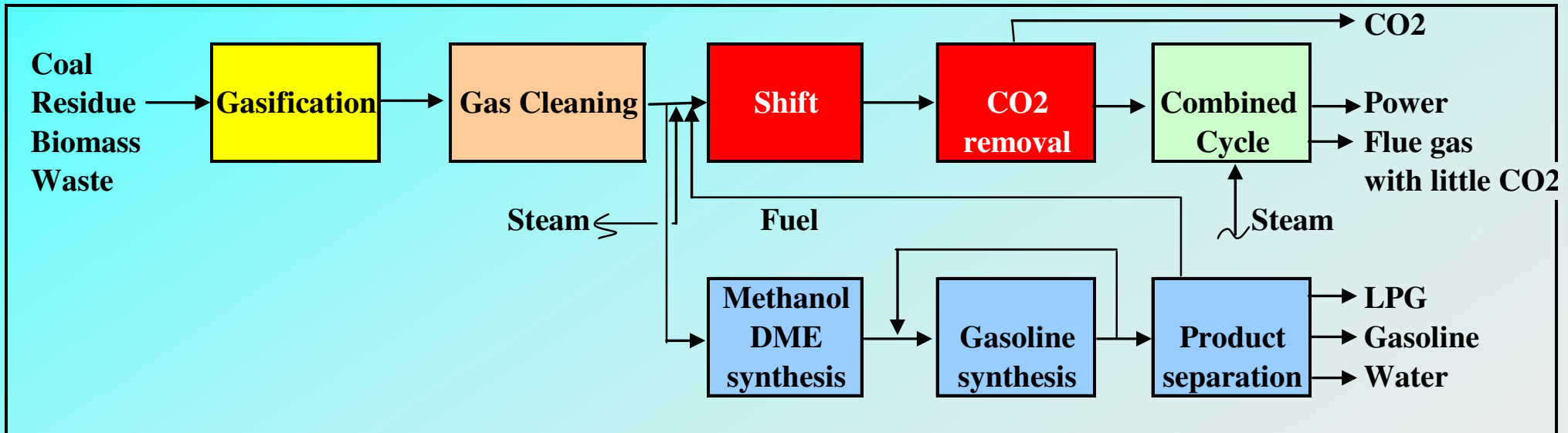

# Conclusions

- **Topsøe's TIGAS process is suitable for polygeneration integrated with an IGCC plant**
  - Based on coal, waste, biomass
- **Fast pay-back times are achieved for the TIGAS unit given realistic power and gasoline values**
- **Operational flexibility offers improved economics**
- **Topsøe is preparing to demonstrate an improved TIGAS process through a Danish government sponsored PSO project**





Risø International Energy Conference 2007, 22 - 24 May

# Sustainable bioethanol production combining biorefinary principles and intercropping strategies

Mette Hedegaard Thomsen  
Henrik Hauggaard-Nielsen  
Anneli Petersson  
Anne Belinda Thomsen  
Erik Steen Jensen

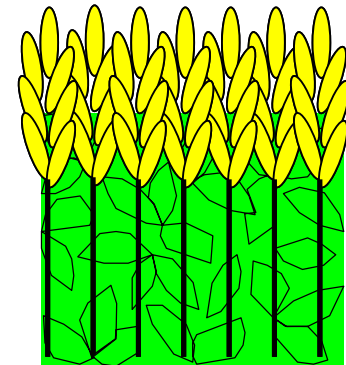
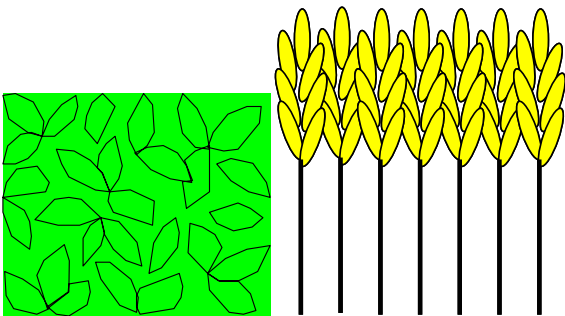

# Bioethanol

## 1. generation Bioethanol:



Substrate: Sugar (sucrose) from sugarcane and starch from corn or wheat.

No chemical/physical pretreatment of biomass before enzymatic hydrolysis.

Optimised, commercial enzymes available

## 2. generation Bioethanol:



Substrate: Lignocellulosic materials (straw, corn stover, wood, waste)

Chemical/physical pretreatment necessary to facilitate enzymatic hydrolysis.

Expensive, non-commercial enzymes

## 2. generation Bioethanol production

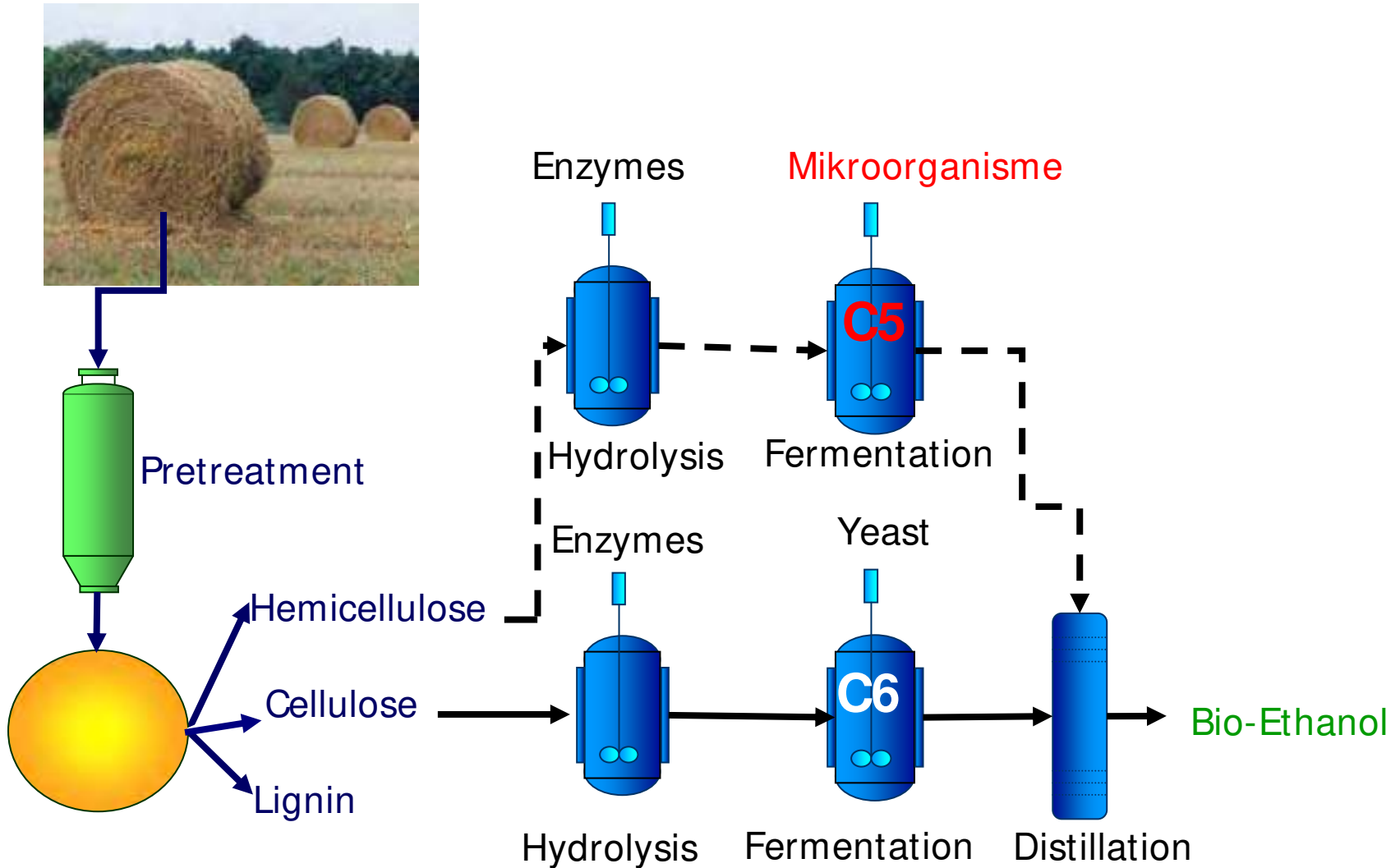



## Wet oxidation



Pre-treatment method most suitable for annual crops such as wheat straw and corn stover.

### Exothermic reaction:

- High temperature
- High pressure
- oxygen
- Reaction time 10-15 min.

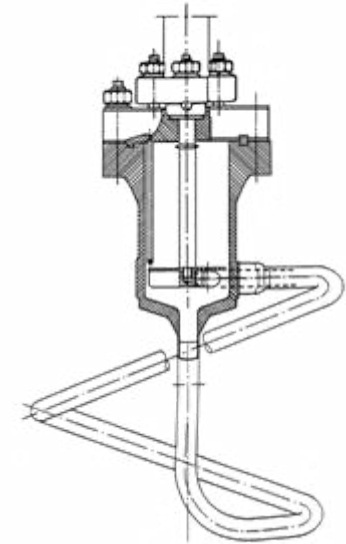

Auto hydrolysis of hemicellulose sugars from the solid fraction because of production of carboxylic acids.

## Choice of biomass resources

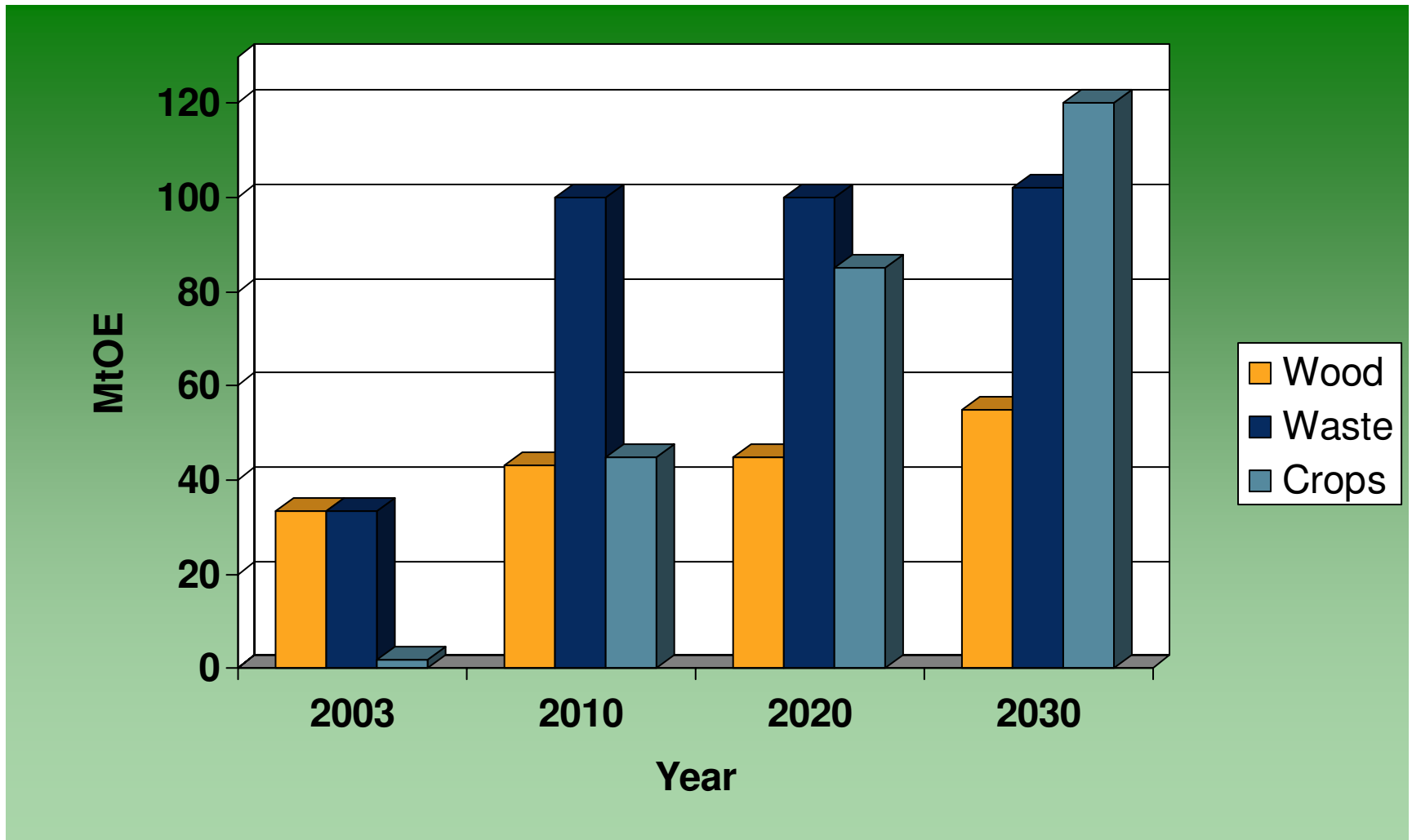



# Choice of crop species and energy consumption

Source: Source ITCF- UNIP (1999)

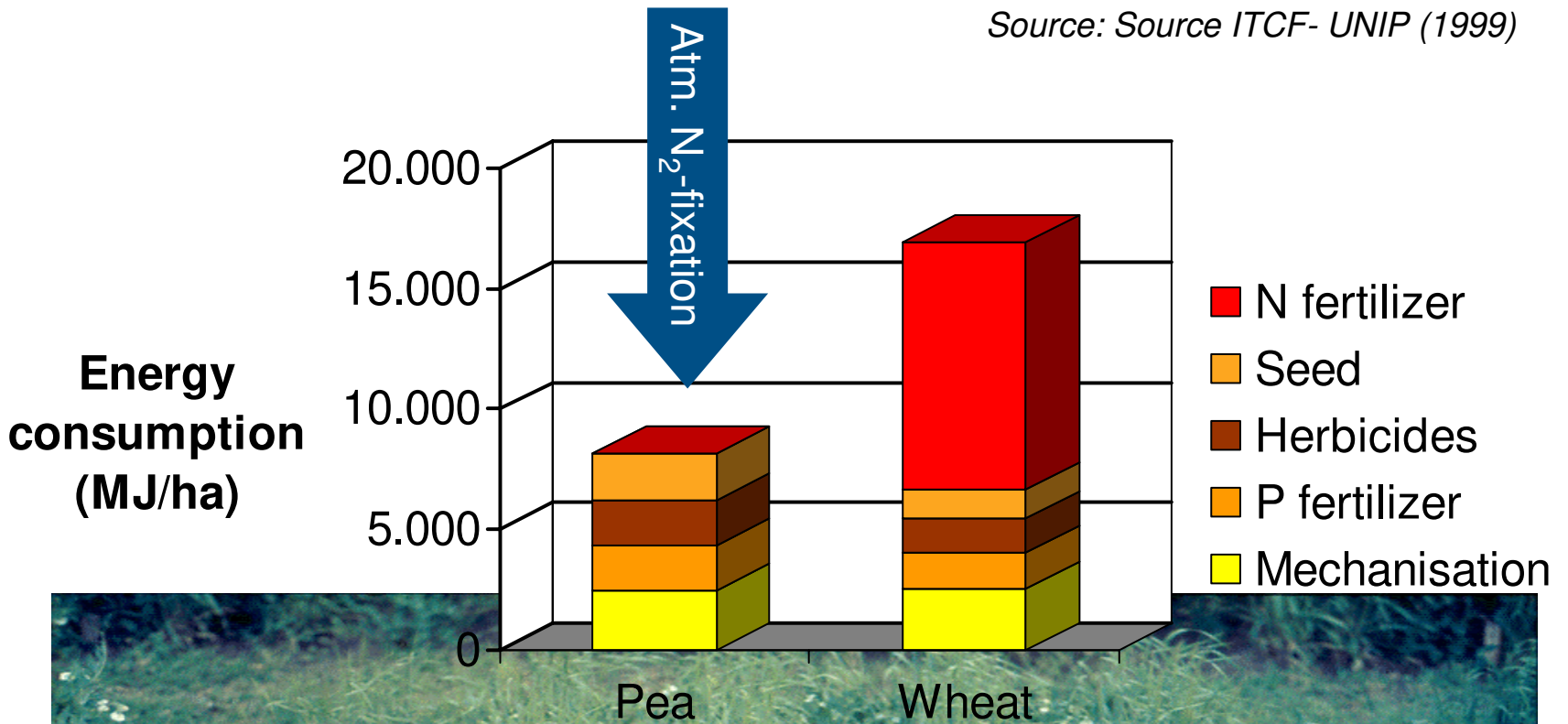

## Criteria to include when producing biomass

- no effect on food production;
- no increase in pressure on biodiversity;
- no increase in environmental pressure;
- no ploughing of previously unploughed permanent grassland;
- a shift towards more environmentally friendly farming
  - agroforestry – local integration and adoption of wood resources
  - perennial energy crops
  - environmental sensitive areas – e.g. groundwater protection

*Source: [http://ec.europa.eu/energy/res/biomass\\_action\\_plan](http://ec.europa.eu/energy/res/biomass_action_plan)*

- It is required to design new cropping methods and multifunctional cropping systems when addressing a "new" issue - **energy**.
  - low-input systems (energy and pesticides)
  - harvest, storage and transportation
  - Win-win solutions energy, environment, and recreation

## Intercropping as an alternative cropping strategy

- Intercropping is defined as the growing of two or more crops in the same piece of land and on the same time - **planned crop diversity**
  - Associated **interspecies interactions** are tools for:
    - improved utilization of resources (light, water nutrients),
    - increased yield stability,
    - control of nutritional quality of grains
    - managing weeds, pest and diseases in low-input systems
- **LEES NEED FOR PESTICIDES AND FERTILIZERS!!!**

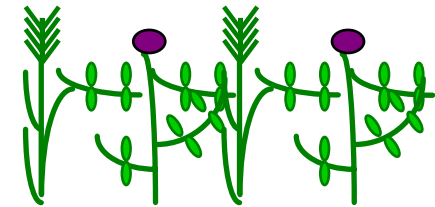

Intercropping

## Complementary use of resources

- Complementarity is implemented in the crop stand when species utilize resources differently

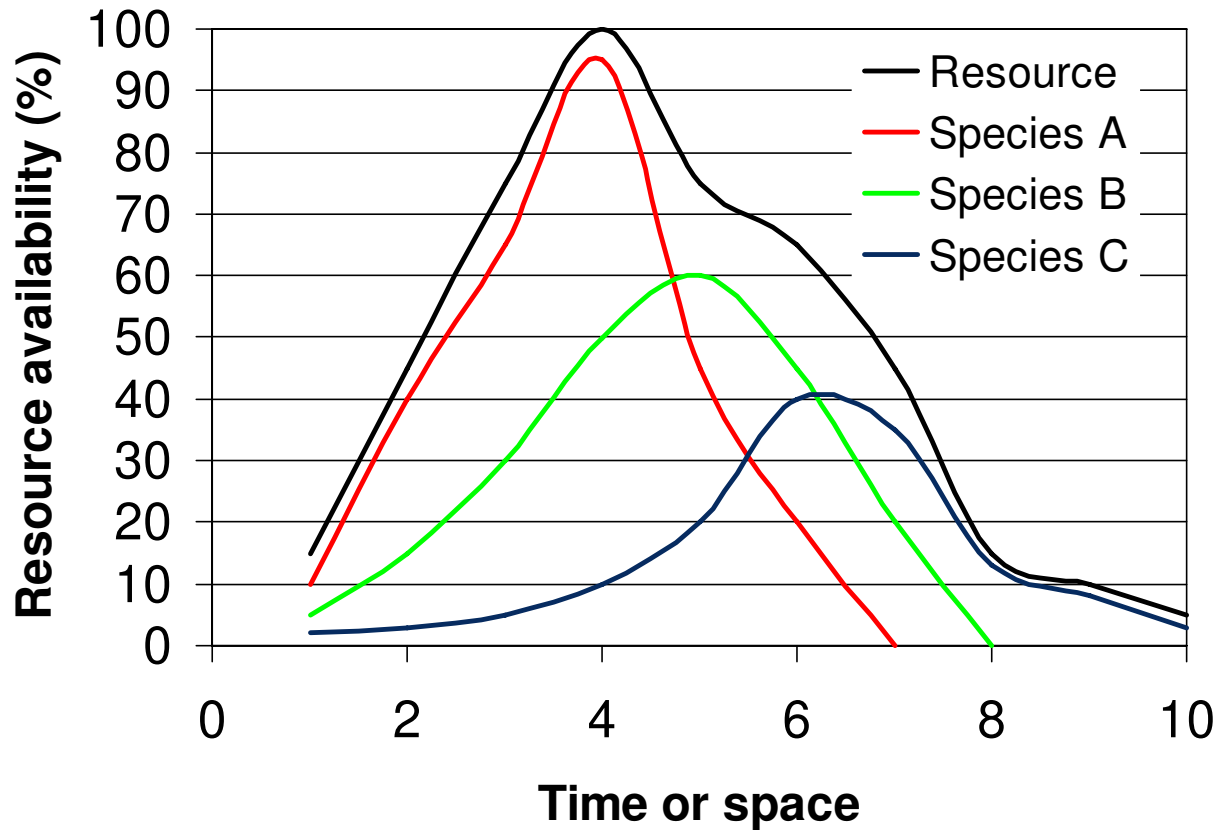

## Clover grass pasture as a potential intercrop raw material

- A mix of white clover (*Trifolium repens* L.) and ryegrass (*Lolium perenne* L.) are important in many agroecosystems today:
  1. high quality feed for livestock
  2. high productivity ( $> 10 \text{ t ha}^{-1} \text{ yr}^{-1}$ ) in unfertilized pastures, with 95% of the N from  $\text{N}_2$  fixing clover (Høgh-Jensen and Schjørring, 1994)
  3. their roots and stubble contain  $60\text{-}110 \text{ kg N ha}^{-1}$  (Hauggaard-Nielsen et al., 1998) reducing N requirements for succeeding crops
  4. integration of pastures diversify the traditional cereal rich rotations
  5. fields with clover grass pastures can be harvested several times a year and the green biomass can be collected and processed to ethanol throughout the year.

## Clover grass as raw material for bioethanol production

- Rich in carbohydrates: cellulose and hemicellulose
- Rich in minerals, especially nitrogen ↓ nutrients for yeast in fermentation



### Question:

Can the sugars in clover grass be converted to ethanol after pretreatment and enzymatic hydrolysis ?????



# Carbohydrate composition



<b>Biomass</b>	<b>Cellulose</b> (g/100 g DM)	<b>Hemicellulose</b> (g/100 g DM)	<b>Ligning</b> (g/100 g DM)
Wheat straw	33.9	23.0	19.1
Clover	16.6	10.5	14.4
Grass	23.9	17.5	12.8

## Clover grass – mineral composition

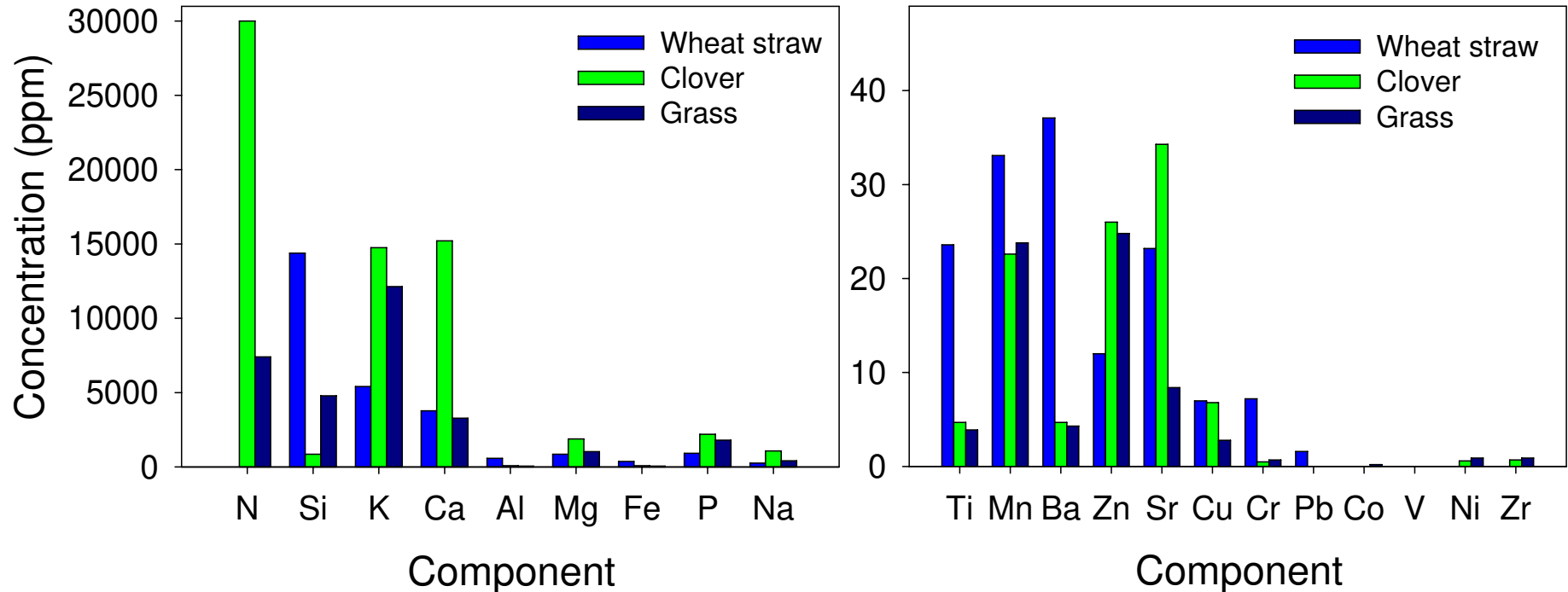

High mineral content  $\Rightarrow$  sufficient nutrients for microbial fermentation  $\Rightarrow$  less fossil energy input in ethanol process



## Pretreatment conditions

- Clover-grass mixture (1:1) were cultivated in the experimental fields of Risø National Laboratory, Denmark.
- Samples of pure clover and grass - and 1:3 clover-grass mixture - was separated by hand.
- The samples were dried at 50°C to constant weight and milled to a size of less than 2 mm prior to pretreatment and further analysis.
- Wet oxidations were performed in the loop autoclave using 6% dry matter (DM) at different process parameters. The pretreated biomass was filtrated into a fiber fraction and a liquid fraction.

Material	Temp. (°C)	Time (min)	O <sub>2</sub> (bar)	Na <sub>2</sub> CO <sub>3</sub> (g/l)
Clover	195	10	12	2
Grass	195	10	12	2
CL-G (1:1)	175	10	3	
CL-G (1:1)	175	10	12	2
Cl-G (1:1)	185	10	3	
Cl-G (1:1)	185	10	12	2
CL-G (1:1)	195	10	3	2
Cl-G (1:1)	195	10	12	
Cl-G (1:1)	195	10	12	2
Cl-G (1:3)	195	10	3	2

# Pretreatment Yields

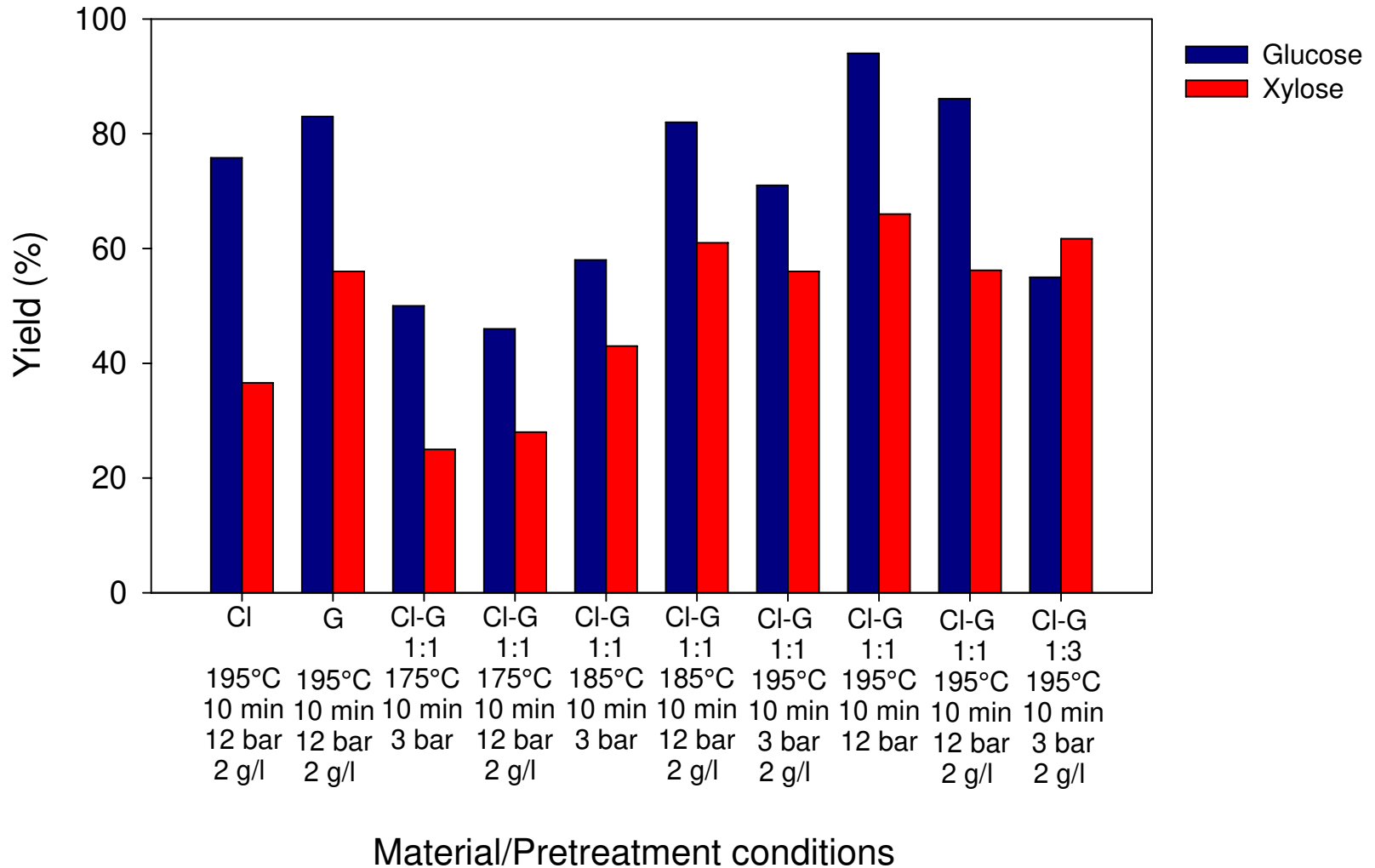

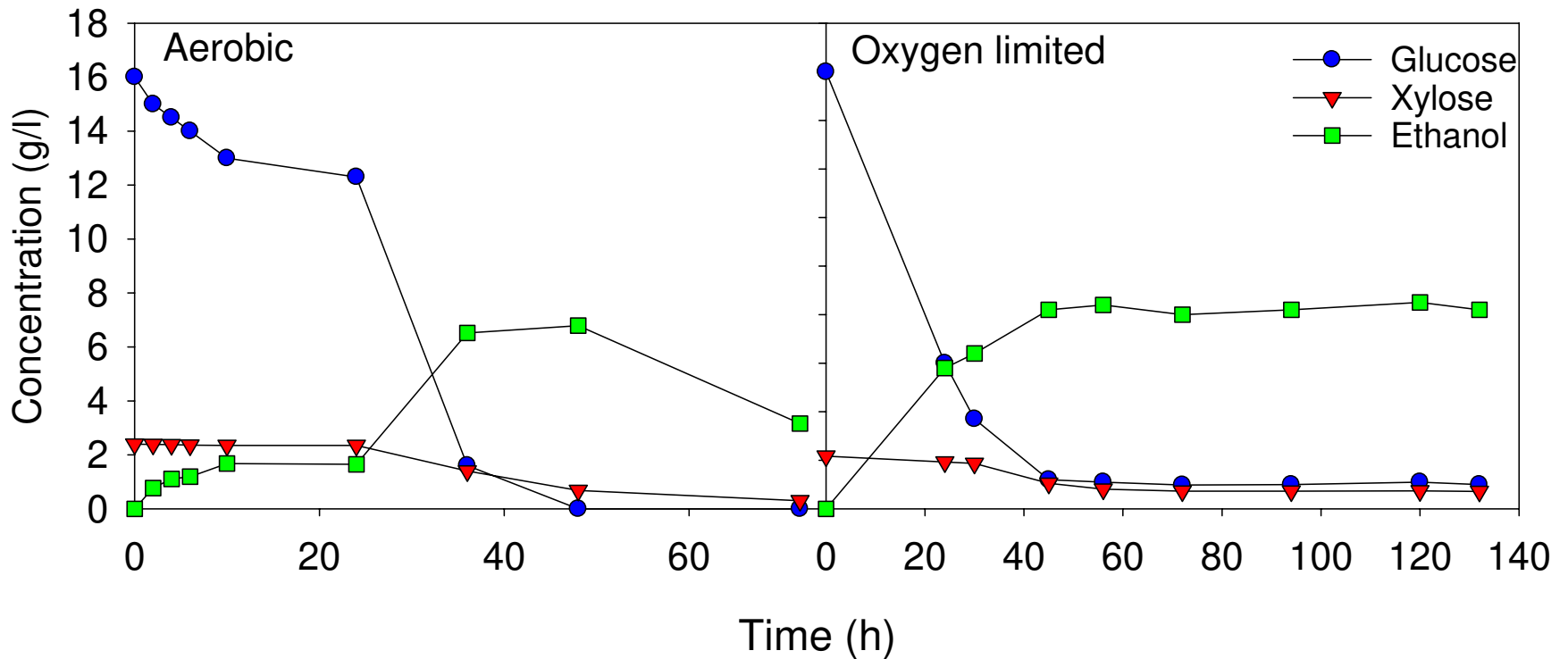
Fermentation of pretreated clover grass with *Mucor indicus*

## Yeast fermentation of **fresh** clover grass

Fructans are polymeric carbohydrates consisting of variable numbers of fructose molecules with terminal sucrose.

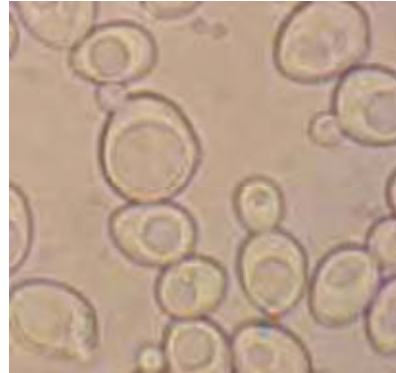

Grass and clover contains significant amount of fructans:

Grass: 166 g/kg DM

Clover: 111 g/kg DM

Plant fructan hydrolases are active at pH 4.5 - 5.5 and temp. 25 - 40°C ⇒

Activity during yeast fermentation at 32°C and pH 4-6.

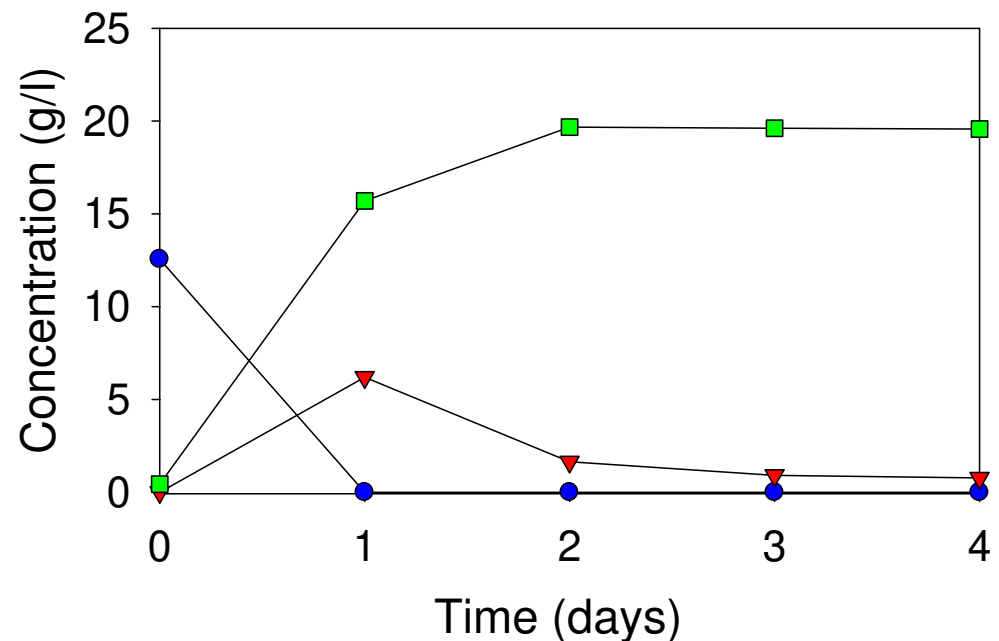

# Biorefinery concept

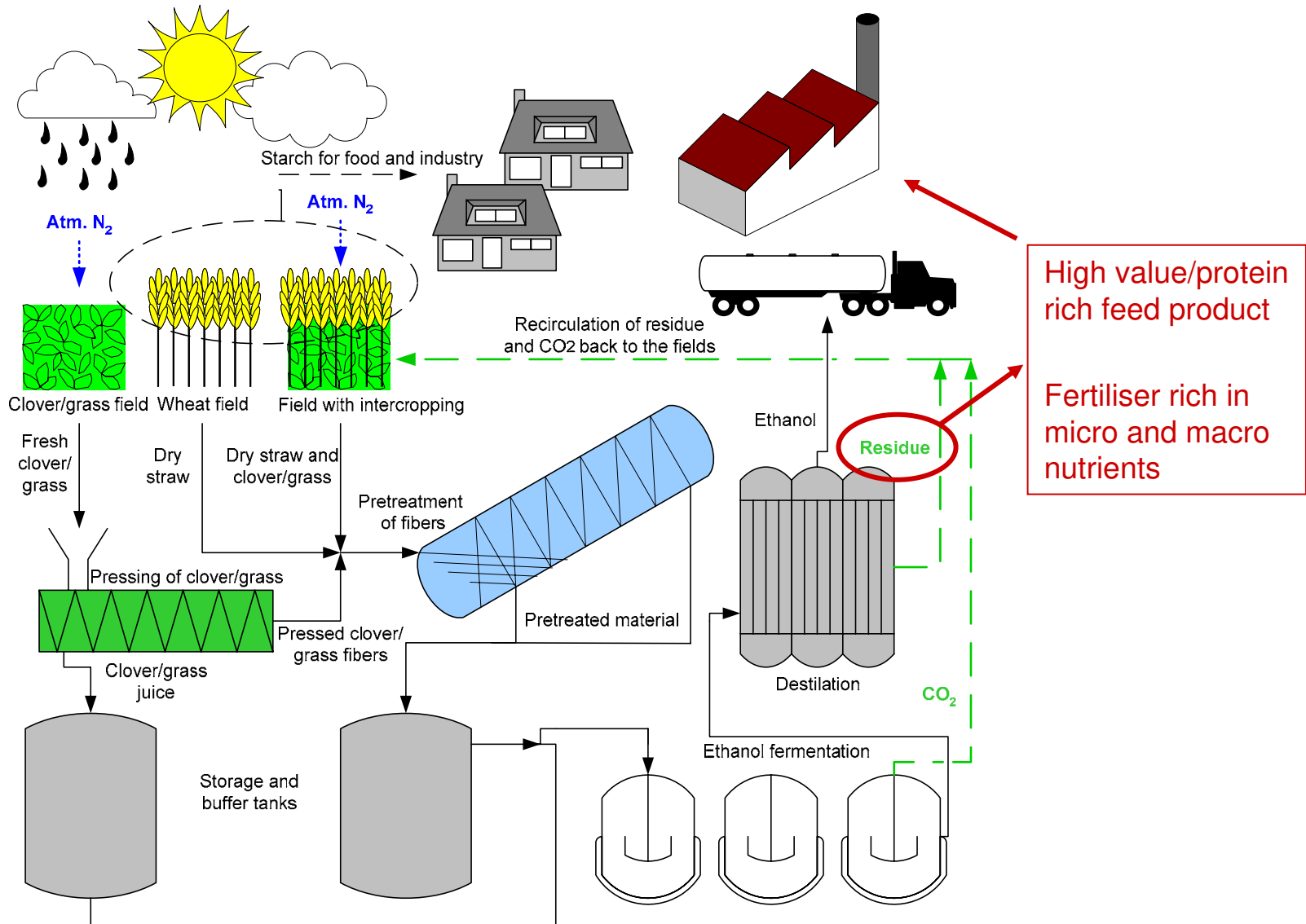

## Theoretical ethanol production

The highest sugar yields were obtained with clover grass pretreated at 195°C for 10 min. using 12 bar O<sub>2</sub> and no Na<sub>2</sub>CO<sub>3</sub>.

$$Y_{\text{cellulose}} = 94 \%$$

$$Y_{\text{hemicellulose}} = 66 \%$$

203 kg cellulose/ton DM clover grass  $\Rightarrow$  107 kg ethanol/ton DM

140 kg hemicellulose/ton DM clover grass  $\Rightarrow$  63.5 kg ethanol/ton DM

138 kg fructan/ton DM clover grass  $\Rightarrow$  ~ 70.6 kg ethanol/ton DM (depending on yield)

**Total: 241 kg ethanol/ ton DM ~ 2.4 ton EtOH/ ha**

Wheat straw: ~ 250 kg ethanol/ton DM ~ 1.25 ton/ha (IBUS treatment)

Clover grass pasture undersown in wheat ~ 964 + 125 kg EtOH/ha = 2.2 ton/ha + **grain for feed**



## Conclusions

- Starch is an important food source, lignocellulose should be the primary raw material for bio-fuel production
- Biomass for bioethanol production should be cultivated using the lowest possible input of fossil energy
- This can be achieved by novel cropping strategies like intercropping combining crop species for food/feed and energy
- Clover grass is a promising raw material for bioethanol production *e.g.* in combination with wheat straw (Thorsted et al. 2006)
- The sugar yields after WO of clover grass were:  $Y_{\text{cellulose}} = 94 \%$ ,  $Y_{\text{hemicellulose}} = 66 \%$  - giving a theoretical ethanol production of 241 kg/ton DM
- All sugars in alternative raw materials like clover grass can be utilised by using the right biorefinery concept

## Perspectives

**Biomass for energy** is considered a key diversification strategy to improve energy supply security and mitigate GHG emissions. However, bioenergy systems are relatively complex, intersectoral and sitespecific. Therefore, solving problems is challenging and requires synergic contribution of various contributors from the **agriculture, forestry, energy industry and environmental sectors** to elucidate the most promising pathway for development.

**Are we able to create such interdisciplinary collaborations?**



**Thank you for your attention!**



# Pretreatment of clover grass

## Carbohydrate composition of fiber fraction

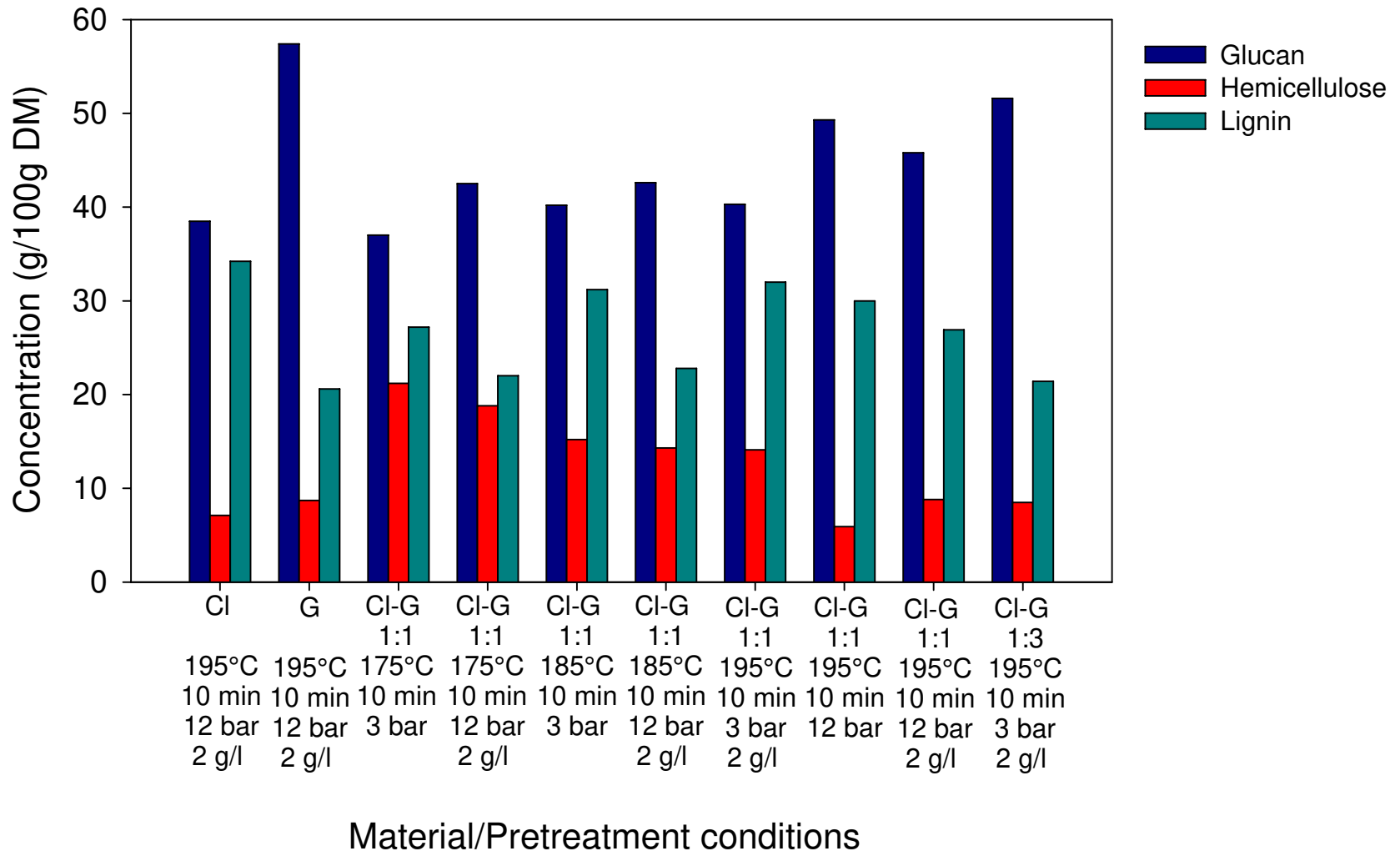

# Pretreatment of clover grass

## Carbohydrate composition of liquid fraction

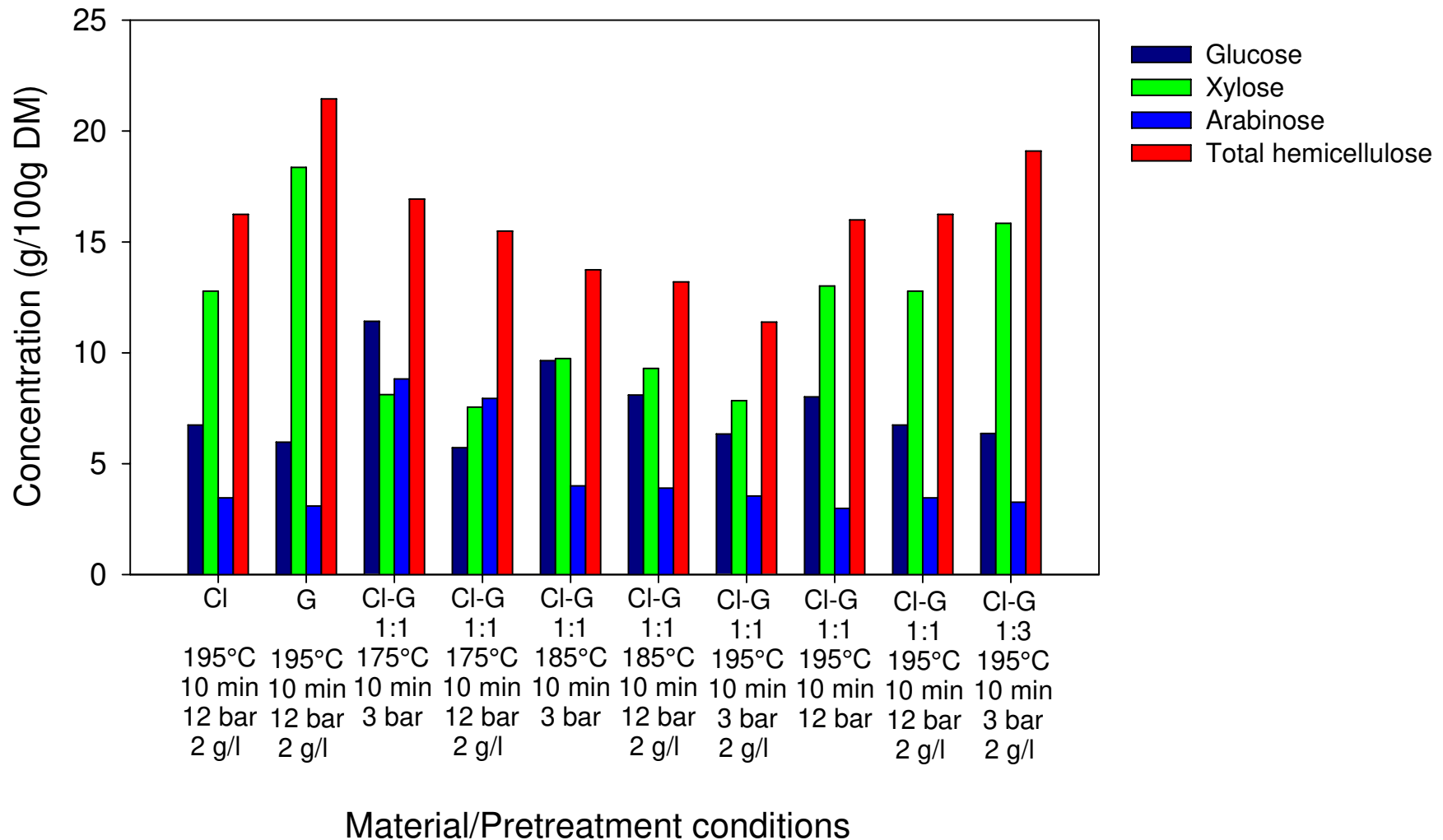

# Co-ordination of Renewable Energy Support Schemes in the EU



**Poul Erik Morthorst and Stine Grenaa Jensen**  
**Risø National Laboratory**  
**The Technical University of Denmark**



## Focus on Renewable Energy technologies

- EU suggests binding targets
  - Greenhouse gases has to be reduced by 20% compared to 1990
  - Renewable energy has to cover 20% of gross energy consumption by 2020 – wind power is expected to have a significant role
  - The existing target for renewable technologies was 12% by 2010 – a share of 8% is expected to be achieved by 2010.
- Burden sharing is to be negotiated
- Ambitious?
  - Anyhow, it is binding

# What happens in Denmark?

## Gross Energy Consumption by Fuel

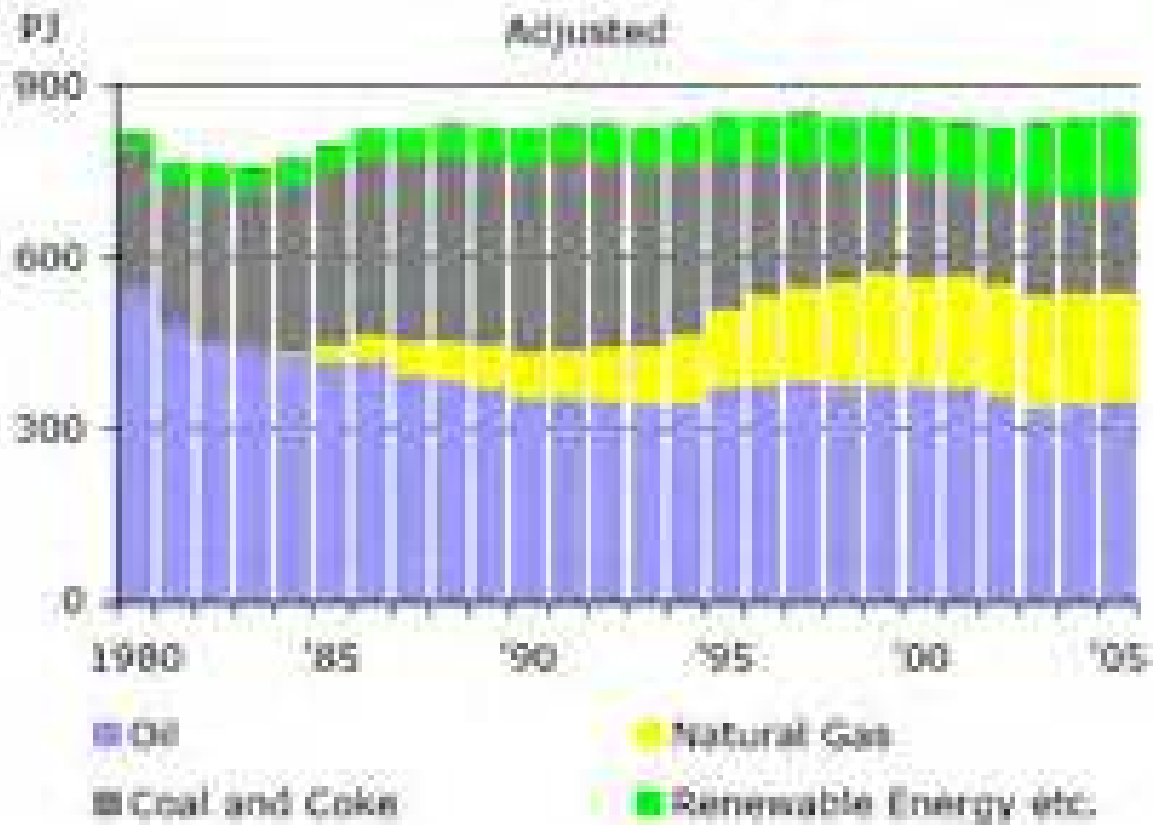

# Constant Energy Consumption in spite of strong growth in GDP

Gross Energy Consumption by Fuel

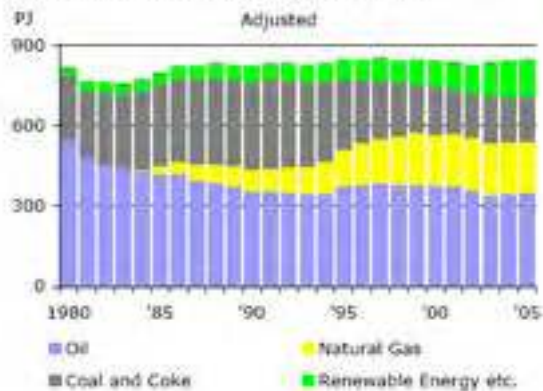

GDP and Gross Energy Consumption

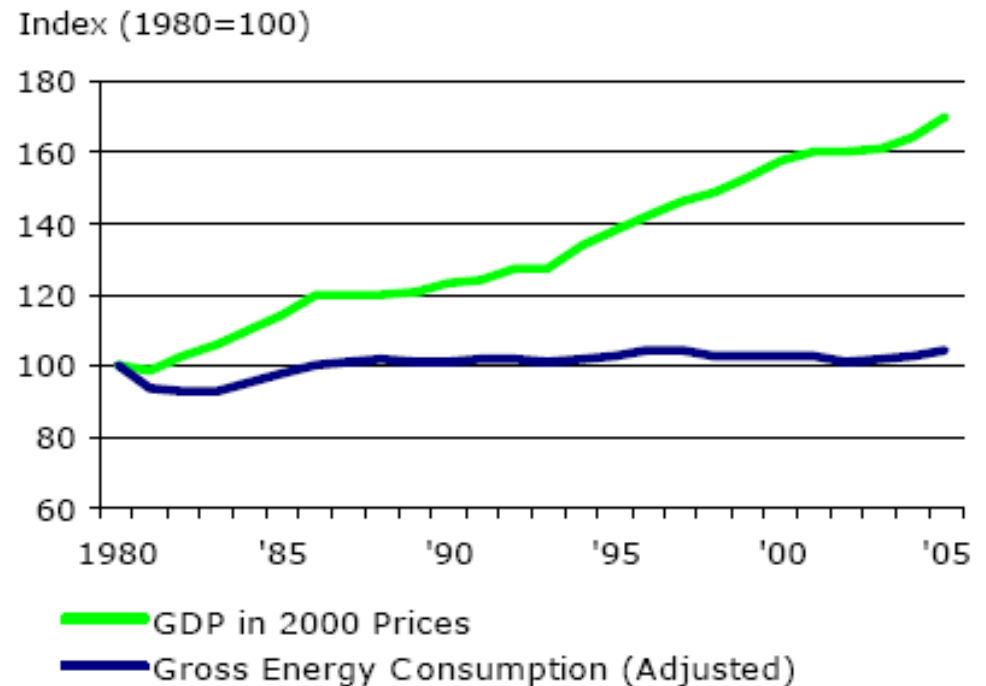

# Strong Increase in Renewables

Gross Energy Consumption by Fuel

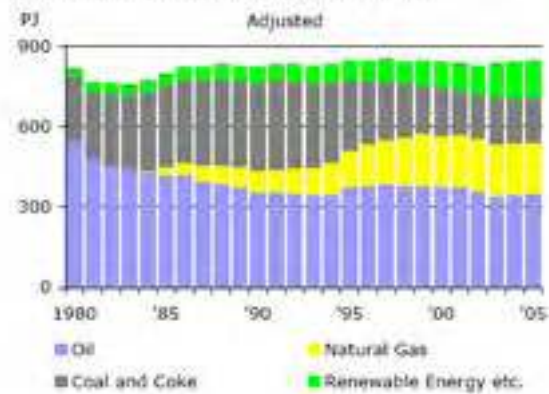

Wind Power - Capacity and Share of Domestic Electricity Supply

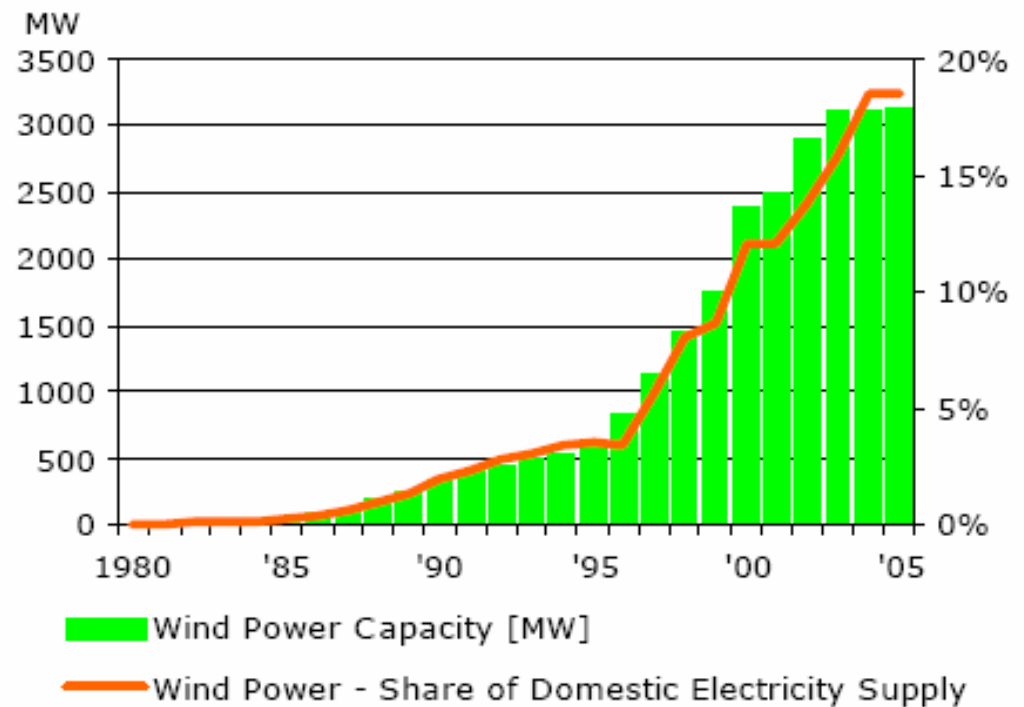



## Strong Increase in Renewables

Wind Power covered approx. 44% of Power consumption in January in Western Denmark

**Wind Power - Capacity and Share of Domestic Electricity Supply**

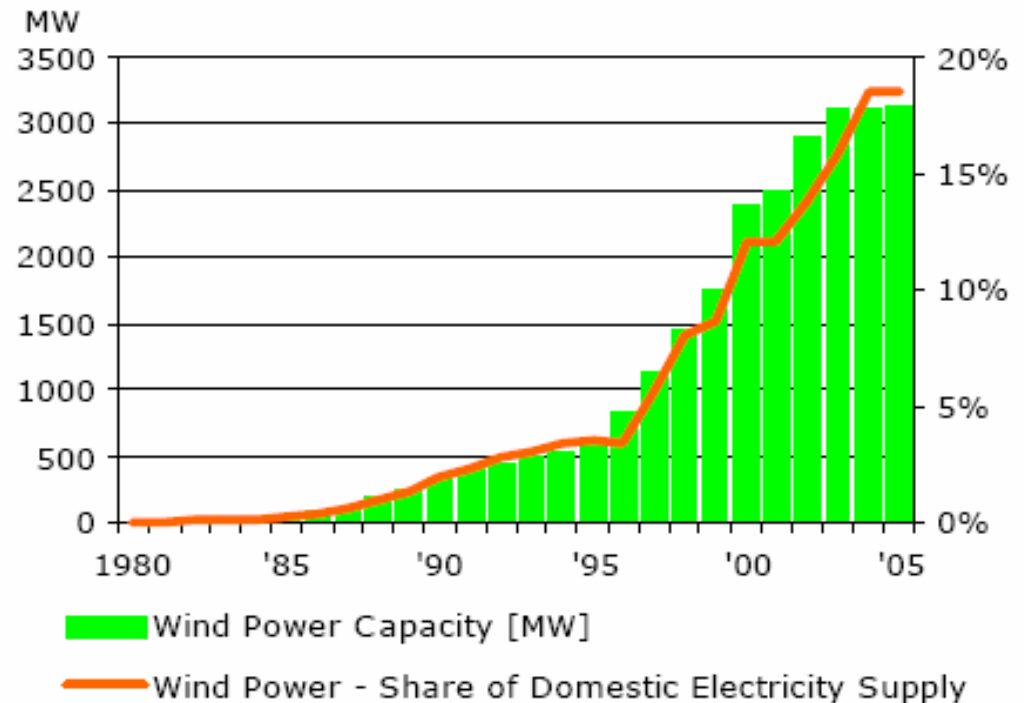

## Strong Increase in Renewables

Wind Power covered approx. 44% of Power consumption in January in Western Denmark

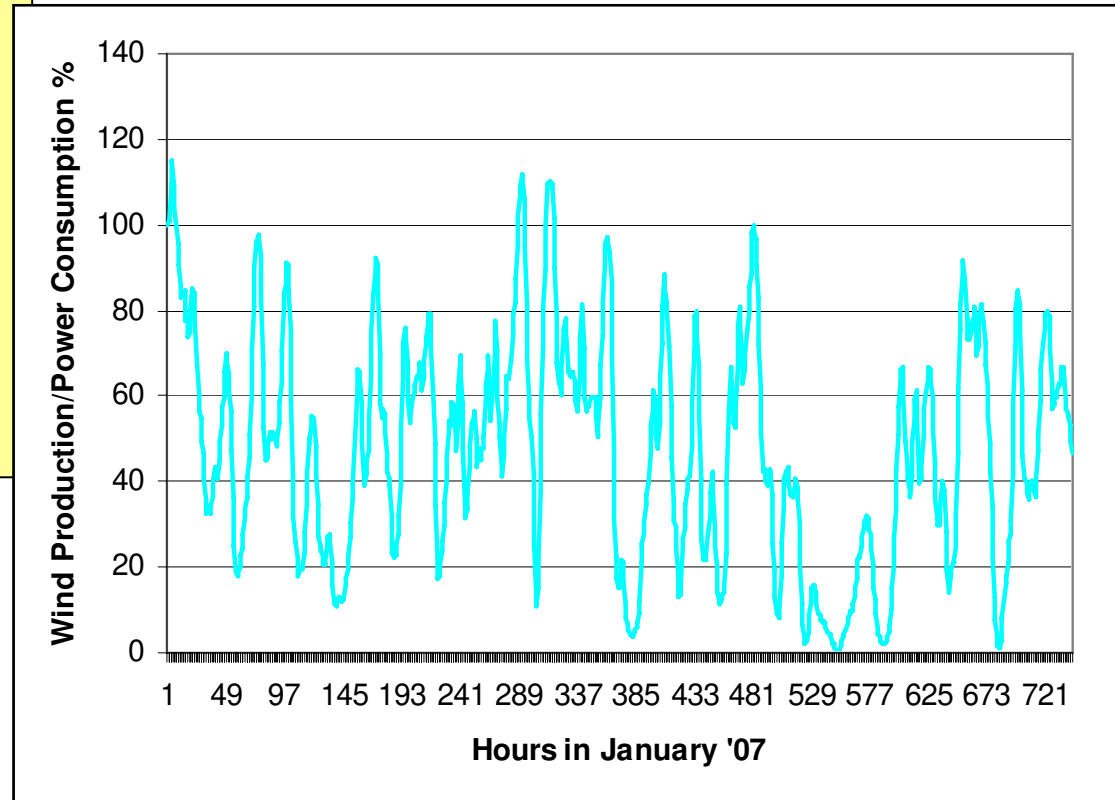

## The New Energy Plan

- Renewables to cover 30% of Gross Energy Consumption in 2025
  - The share is approx. 15% today
- Energy conservation and development of new Energy Technologies
- Wind Power could cover 50% of Danish Power Consumption in 2025

## The New Energy Plan

- Renewables to cover 30% of Gross Energy Consumption in 2025
  - The share is approx. 15% today
- Energy conservation  
Energy Technologies
- Wind Power could cover 30% of Gross Energy Consumption in 2025

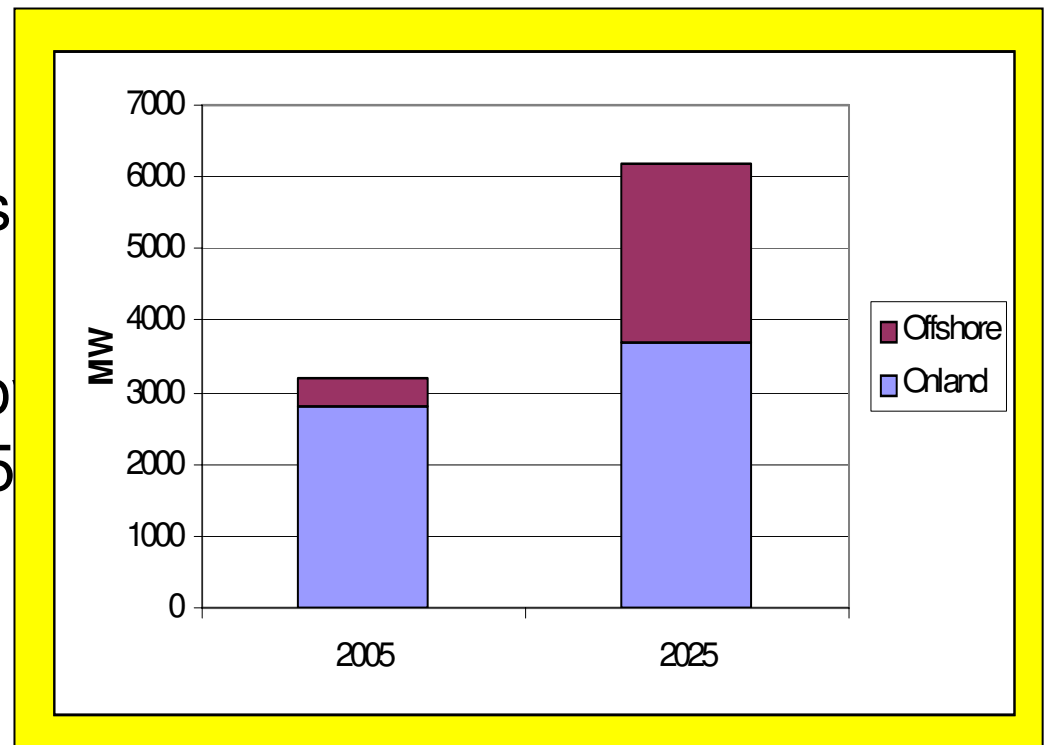

# Support Systems in EU

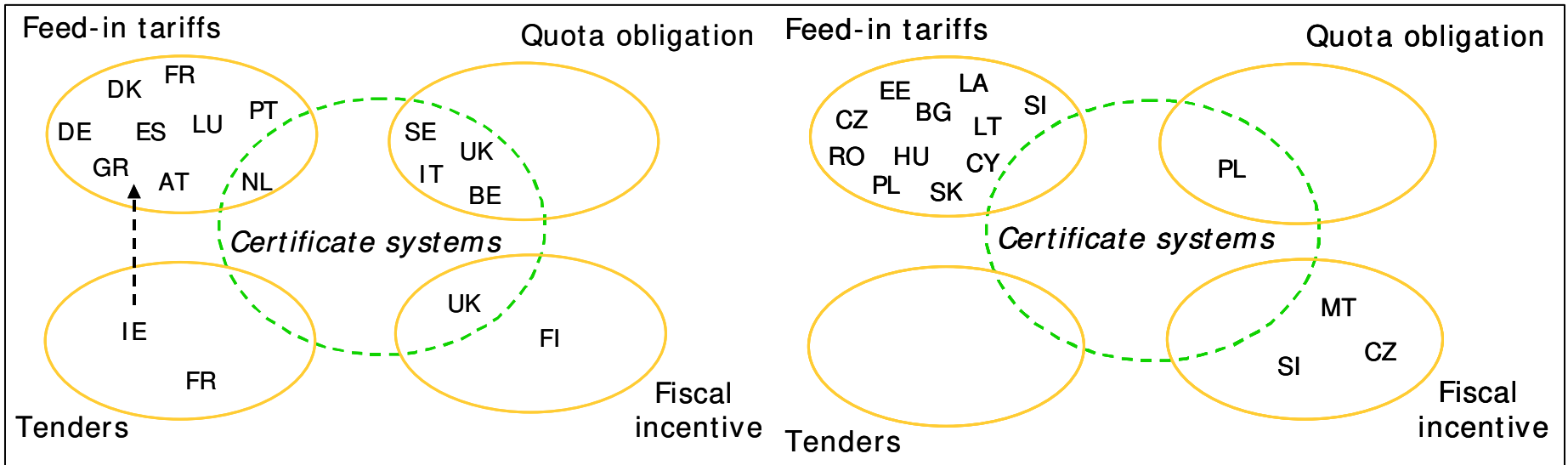

# Support Systems in EU

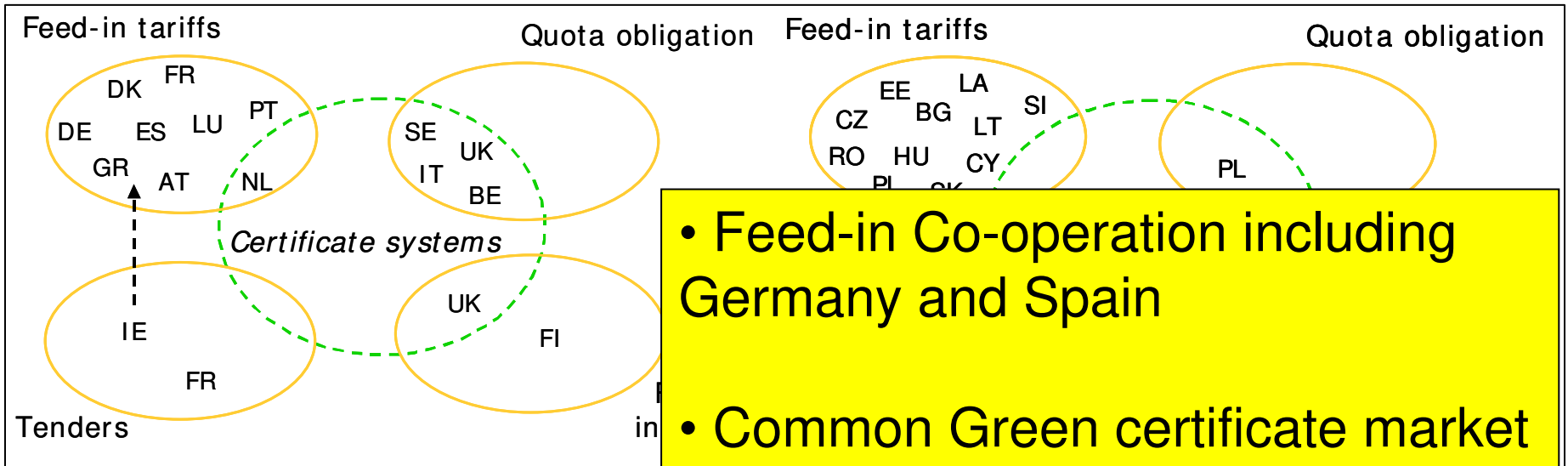

- Feed-in Co-operation including Germany and Spain
- Common Green certificate market including Sweden and Norway
  - **Did not come true!!**

## Future Support Systems and the Internal Market in EU

- **With regard to RES-E, what do we want to achieve in the EU?**
  - An economic and resource efficient siting of renewables
  - A replacement of the most inefficient power plants
  - A reduction of CO<sub>2</sub>-emissions achieved in the most effective and cheapest way
- **Coordination and regionalization**
  - The way forward for RES-E support in the EU
- **Interactions of Power markets and RES support schemes**
  - How can we get the most efficient transition to a coordinated RES-E development in EU?

# Ways to Go – The almost Ideal Case

- Regional power market and regional support system

		<i>Power Market</i>	
		<i>National</i>	<i>Regional</i>
RES-E Support Scheme	<i>National</i>	<b>Case A</b>	<b>Case B</b>
	<i>Regional</i>	<b>Case C</b>	 <b>Case D</b>



**Country A – high wind and efficient system**

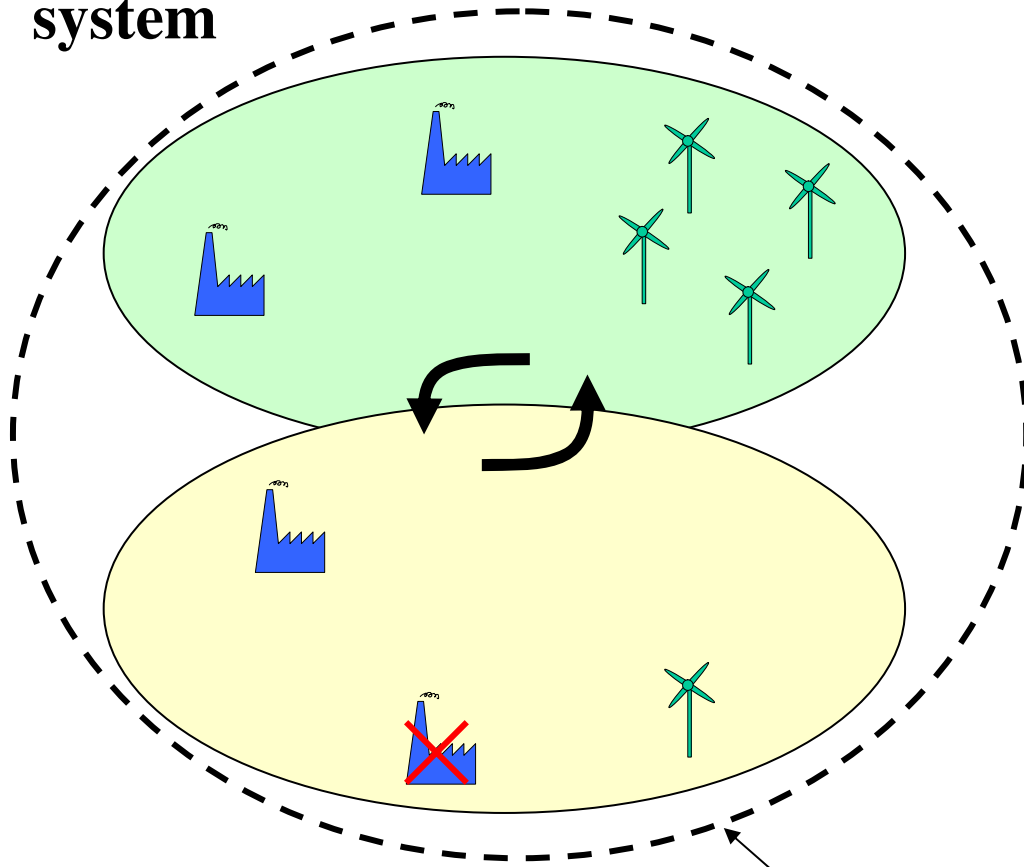

**Country B – low wind and inefficient system**

Common Power Market

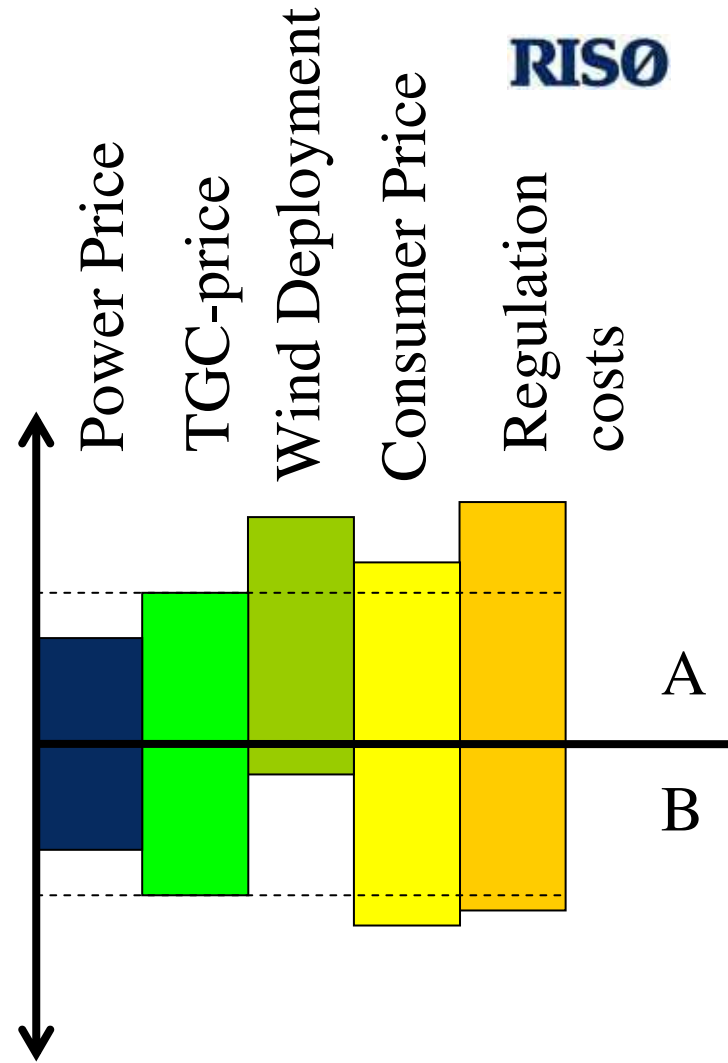

- **Renewables are sited in the most efficient way**
  - Only the wind regime matters
- **Consequences for the Power Market**
  - The most inefficient plants will be replaced by renewables
  - The more different the two countries are the more beneficial will a common TGC-system be
  - Effective reduction of CO<sub>2</sub>, but where the reduction takes place (country A or B) will depend on the marginal conditions at the power market
  - Burden sharing of regulation costs is a problem
- **Comparison to a Feed-in tariff**
  - The burden sharing is implicitly given by the TGC-quotas in each country – thus there is no need for a common fund as will be the case in a feed-in system

## Ways to Go – The troublesome Case

- National Power market and regional support system

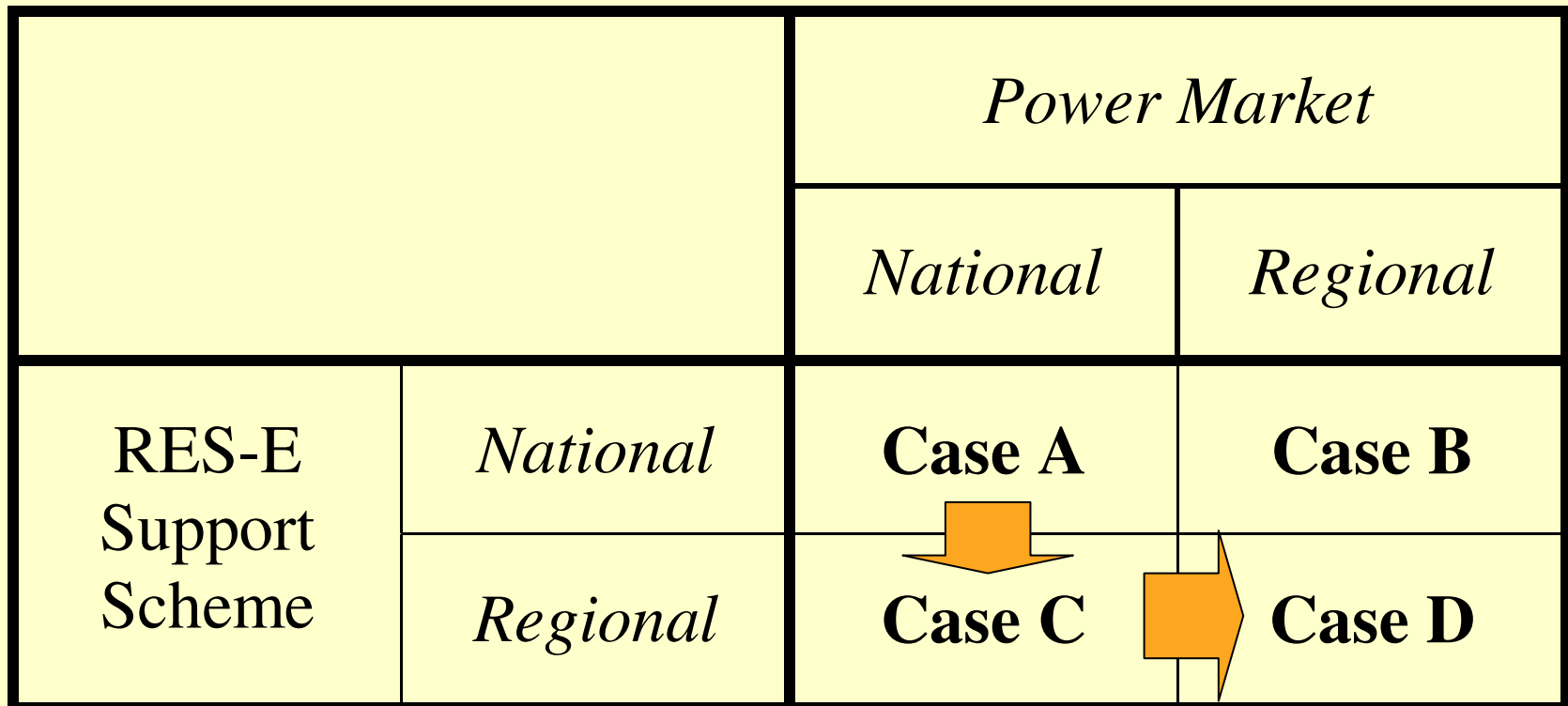

# Tradable Green Certificates - The Troublesome Case

**Country A – high wind and efficient system**

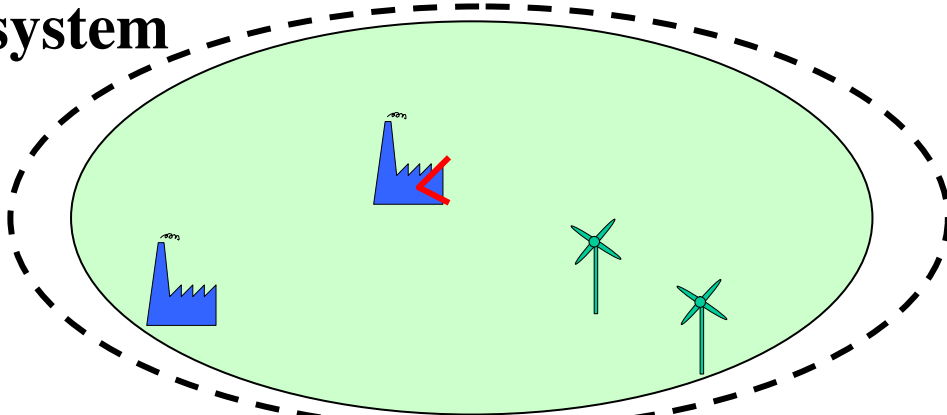

**Country B – low wind and inefficient system**

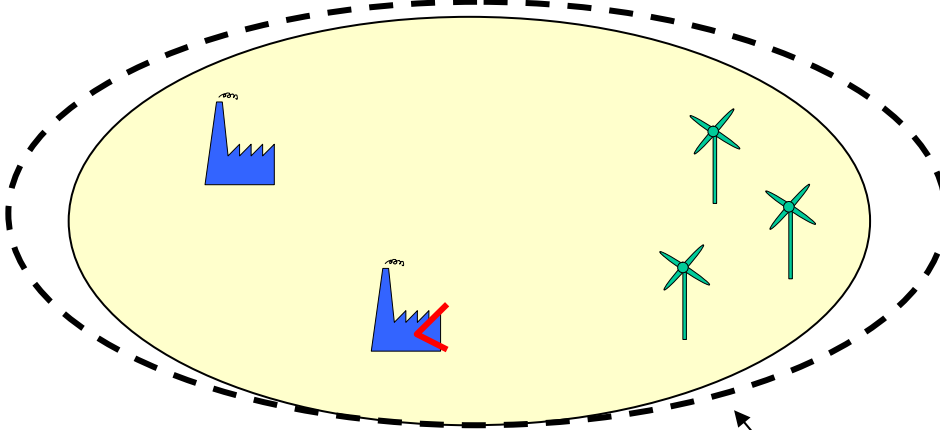

Separate Power Markets

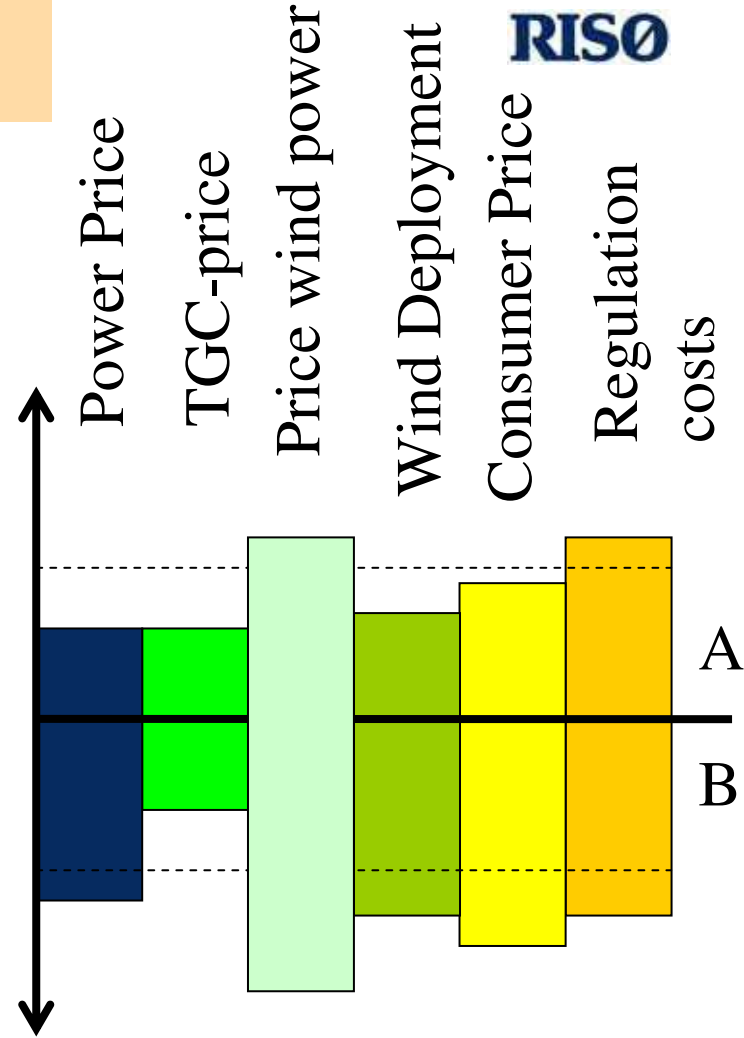

## Green Certificates - Troublesome Case

### *Consequences for renewables and the Power Market*

- Renewables will be sited the most **economic** efficient places, but not the sites with the highest resources
- Renewables will not replace the most inefficient power plants
- CO<sub>2</sub>-reduction in the region will not be efficient implying higher prices for CO<sub>2</sub>-allowances
- Burden sharing of regulation costs is also a problem in this case

### *The Green Certificates system is economically optimal at the given market conditions ..... but*

- **Short term solution** - *If we want to move towards a common power market, a common TGC system does bias both the development of renewables and the conventional power system*

## Conclusions

- A common and efficiently working power market is a prerequisite for an efficient common support system
  - Separate power markets might bias the development of the conventional power system
- But other barriers exist as well
  - Lack of competition (monopolies), weak interconnectors...
- The way forward
  - Co-ordination of support schemes
  - Regionalization

# Bioethanol

## Second generation Bio-fuel – close to commercialisation

Charles Nielsen  
DONG Energy



**IBUS** (Integrated Biomass Utilisation System)

**Inbicon A/S** (new name for **Elsam Biosystems A/S**)  
Integrated Biomass Conversion

Founded 2003 by  
Elsam A/S (now **DONG Energy A/S**) and  
Holm Christensen Biosystemer ApS

for commercialisation of the IBUS concept





# Content

- IBUS technology
- Demonstration
- Commercialisation

# The IBUS concept

## 1. Integrated utilisation of sugar/ starch and lignocellulosic feedstocks

- Most crops comprises both sugar or starch and lignocellulose
- Lower cost from field to plant
- More biomass can be collected within a given area
- Substantial process synergies

# The IBUS concept

## 2. Integrated production of bioethanol and electricity

- Electricity generation loses 55-65 % of the input energy as heat
- Ethanol fermentation loses only 3-5 % of the input energy as heat, but requires a lot of process heat
- The huge loss of heat energy from the global electricity generation can be used to cover the demand for heat energy of the future fuel ethanol production

Co-production is the solution

# The IBUS concept



Surplus steam

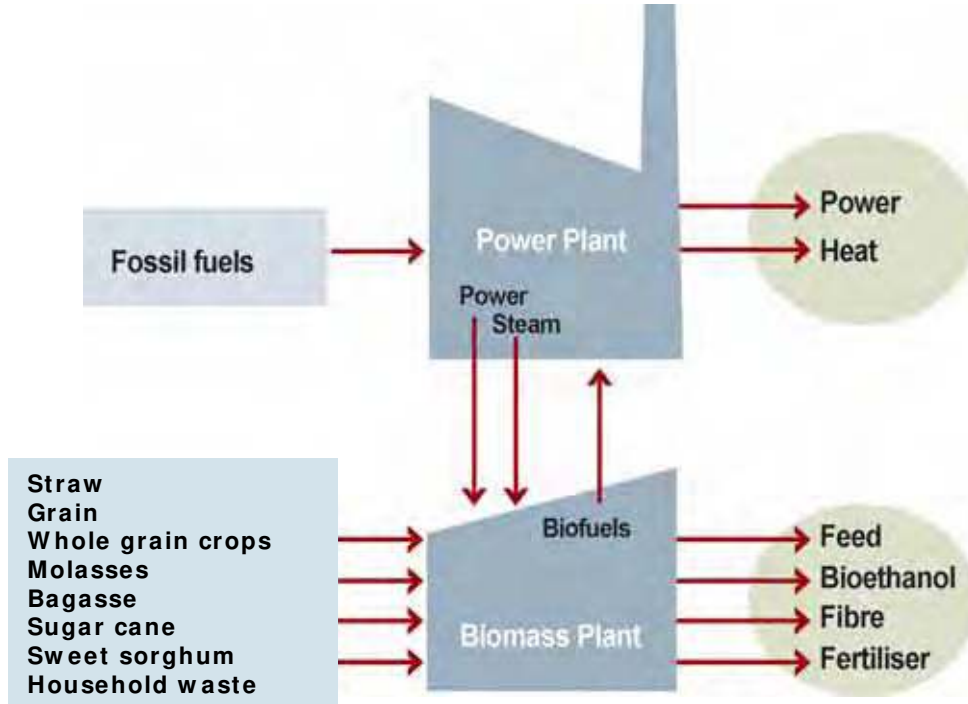

High quality solid biofuel



# The IBUS concept

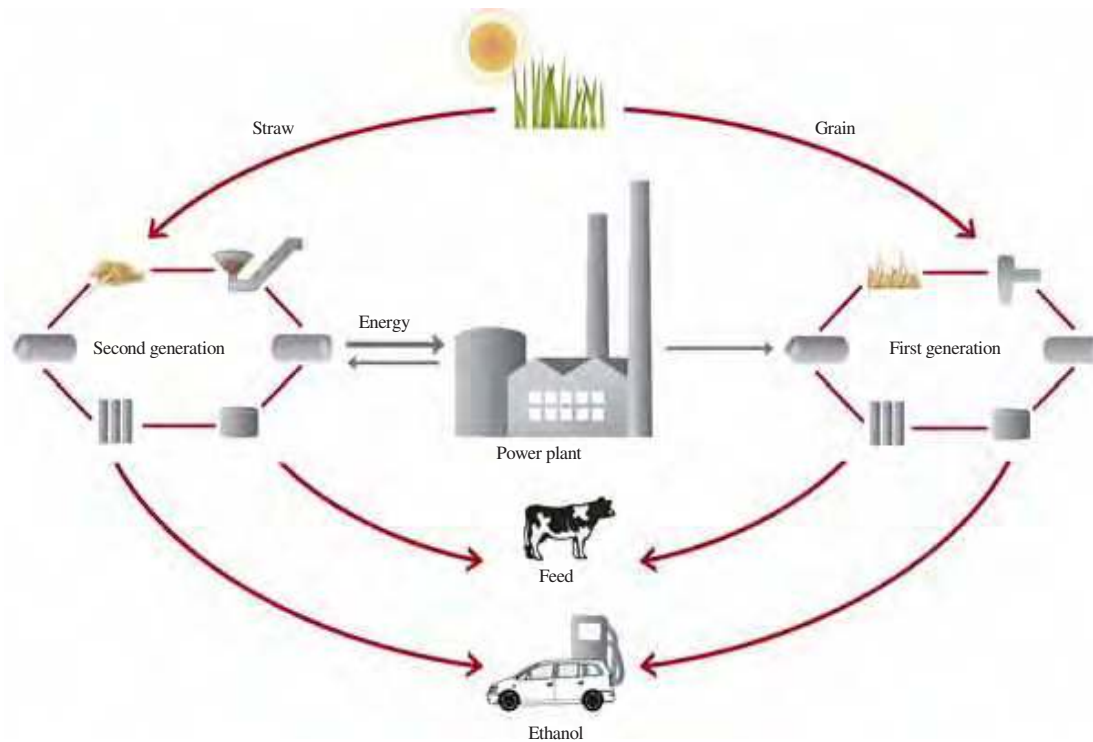

Integration 1. and 2.nd generation technology

Integration with electricity generation and utilization of surplus heat

# The IBUS process

Continued pretreatment

High dry matter content

High energy efficiency

No ligning separation

Recycling of plant nutrients  
(nitrogen, phosphor, potassium,  
and micro minerals)

Integrated water utilization – no  
waste water

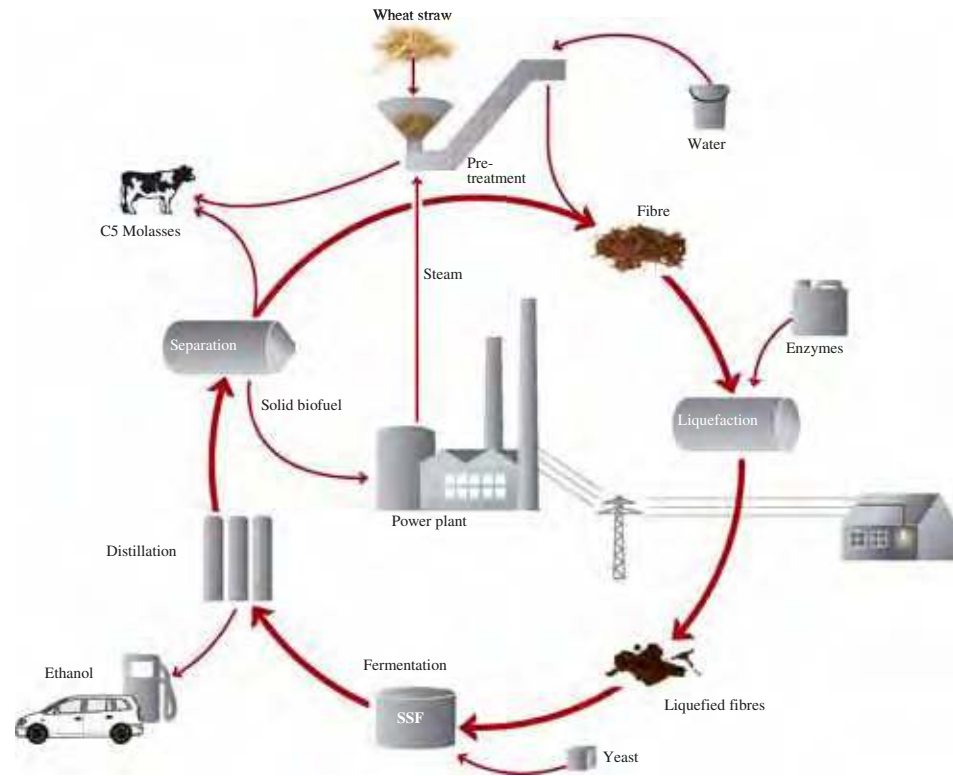

# IBUS results based on wheat straw

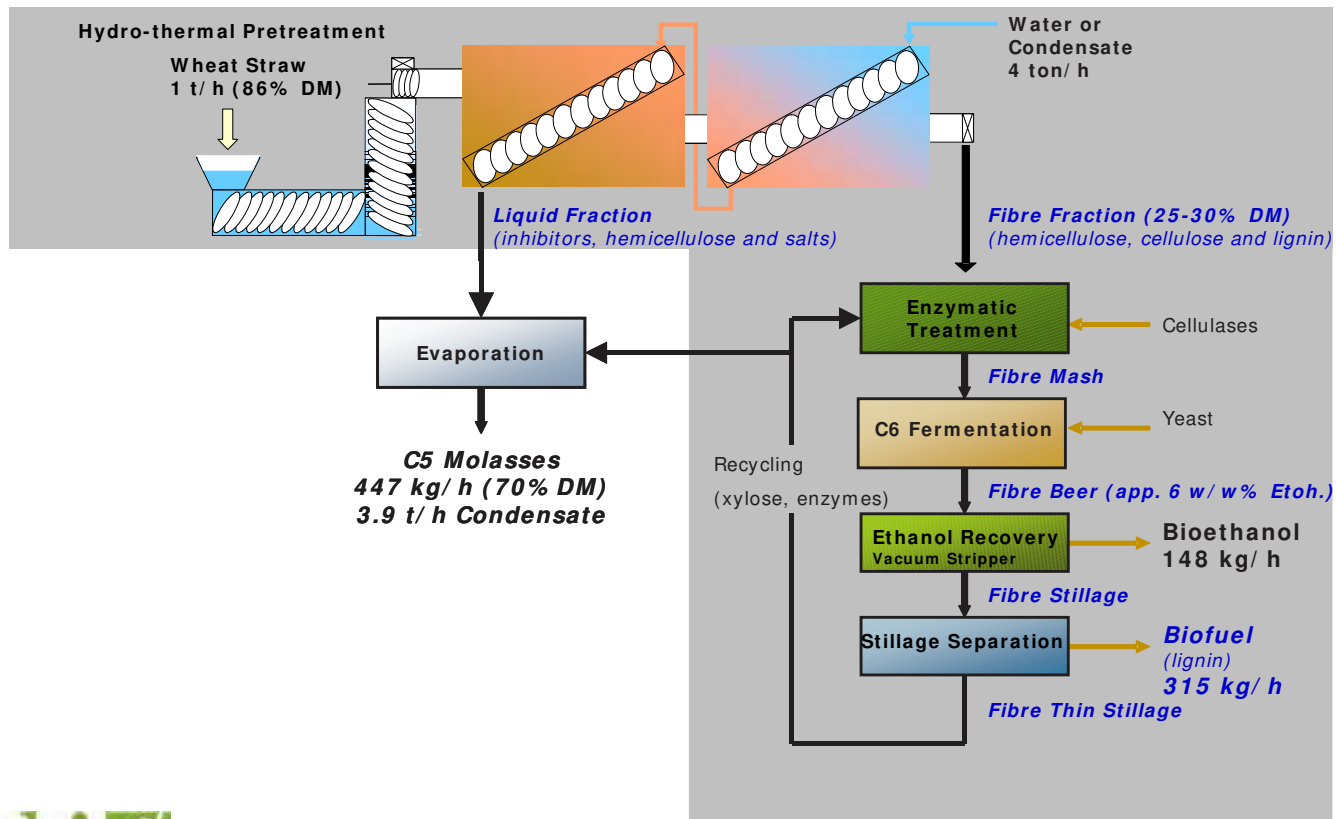

# Pretreatment





# IBUS pretreatment removes lignin as nano-particles

Height Angle Surface Normal Clear Calculator

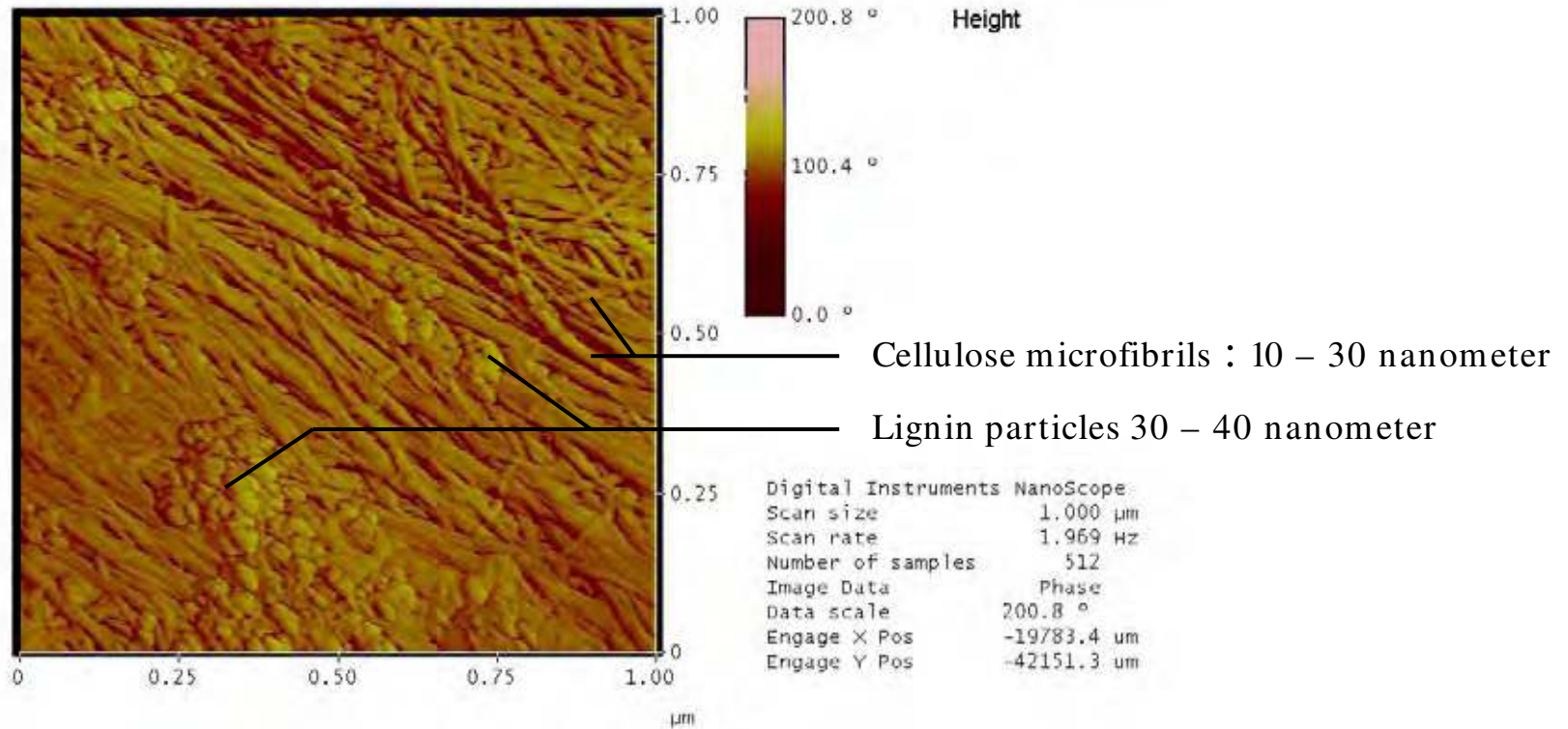

Cellulose microfibrils : 10 – 30 nanometer

Lignin particles 30 – 40 nanometer



Photo:Royal Veterinary and Agricultural University

# Enzymatic liquifaction with high dry matter content



**5 Chamber Liquifaction Reactor**

# Liquifaction with high dry matter content and fermentation (26 % DM)

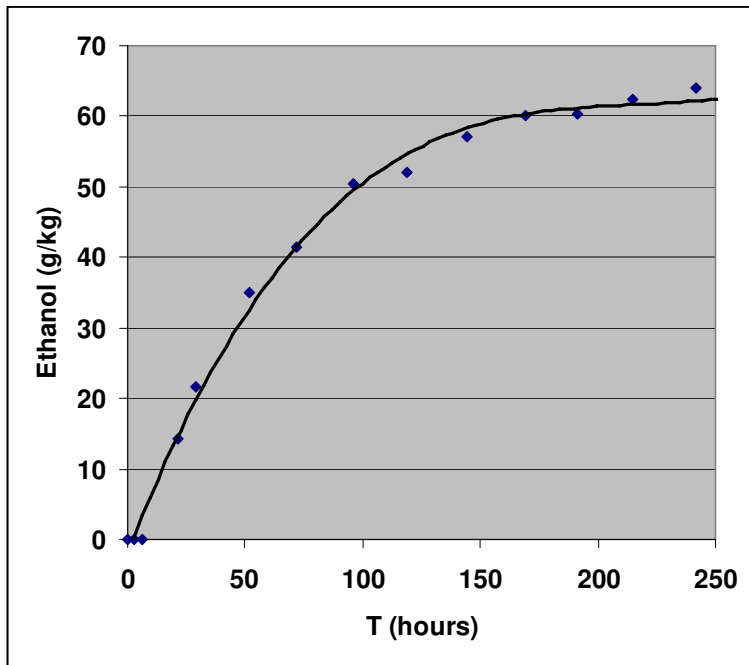

## Ethanol concentration:

- 63 g/kg incl. suspended material
- 83 g/l in the liquid fraction (excl. suspended material)
- 105 ml/l (10,5 vol%) in liquid fraction (excl. suspended material)

# Next step output from the IBUS process

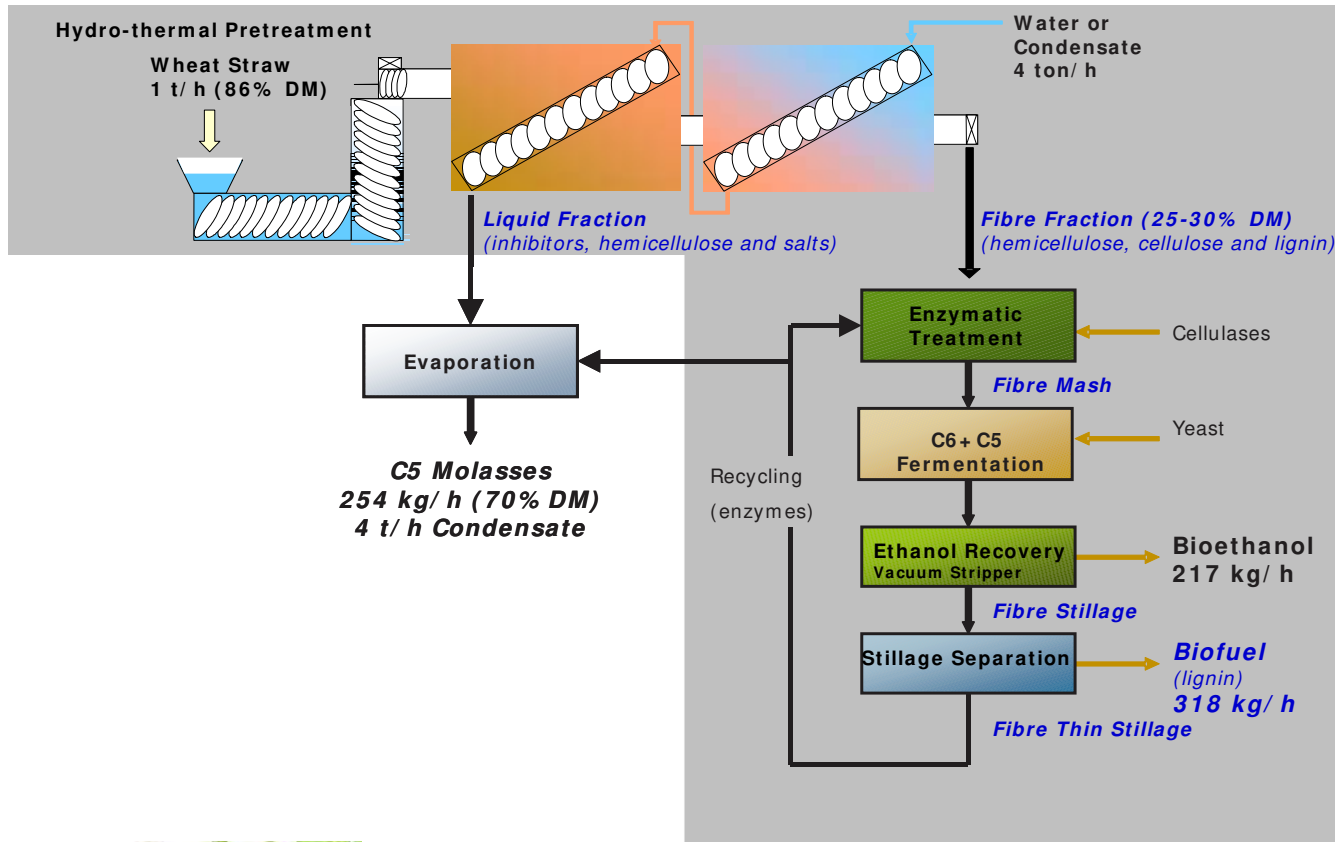

# Actual energy balance (state-of-the-art)

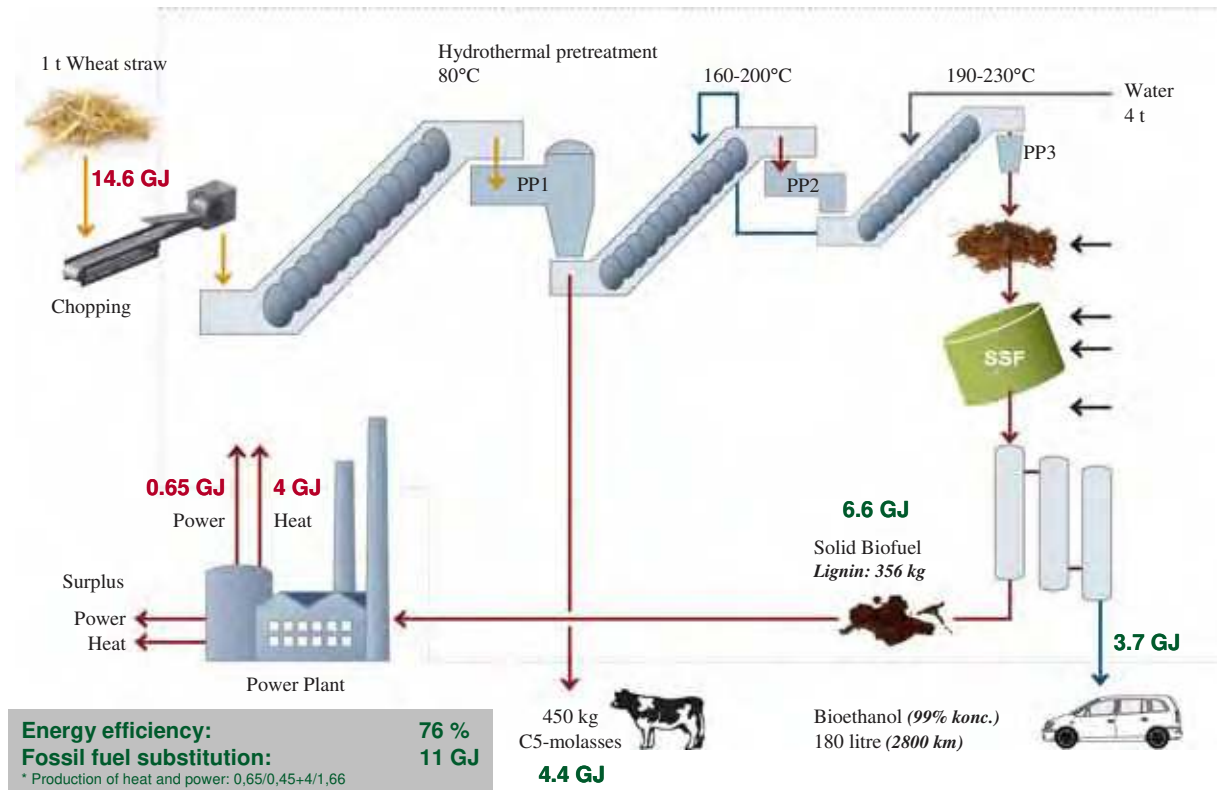

# Main results from the EU project: Co-production of Biofuels

- The IBUS pretreatment can work at high gravity without chemicals
- Fast (5-10 hours), high gravity (30-40 % d.m.) liquefaction at low enzyme concentration (3-4 FPU/ g)
- Effective high gravity fermentation (SSF) of more than 80% of cellulose to ethanol by yeast
- Yeast fermentation can be carried out in the presence of lignin
- See more at [www.bioethanol.info](http://www.bioethanol.info)



# IBUS – Low energy cost

- Low price, 4 bar steam from electricity generation
- High gravity processing reduces steam consumption
- Novel particle generation system saves 50-75% electricity compared to traditional hammer milling
- Novel distillation system energized by heat pumps or 1-2 bar steam, is expected to reduce costs with 50 % compared with traditional systems
- Drying with superheated steam at 3-5 bar generates steam for multistage evaporation recovering about 90% of drying energy
- The lignin fraction can cover the process energy required for conversion of the straw and a similar quantity of grain

# IBUS – long term sustainability

- Use of low pressure steam from electricity generation means energy without CO<sub>2</sub> emission
- Recycling of plant nutrients (nitrogen, phosphorus, potassium and microminerals)
- Recycling of process water and condensates means no waste water
- Drying with superheated steam means no VOC emission



# IBUS – best basis for biorefineries

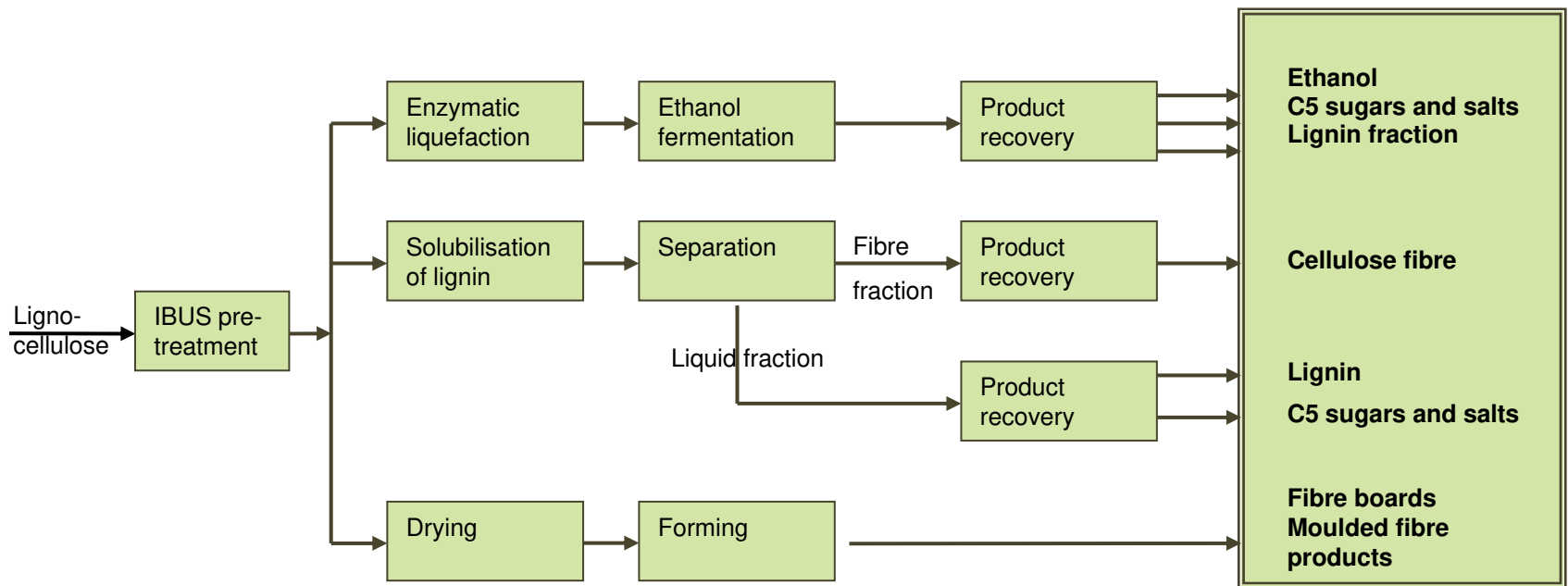

# Stepwise implementation of biorefineries

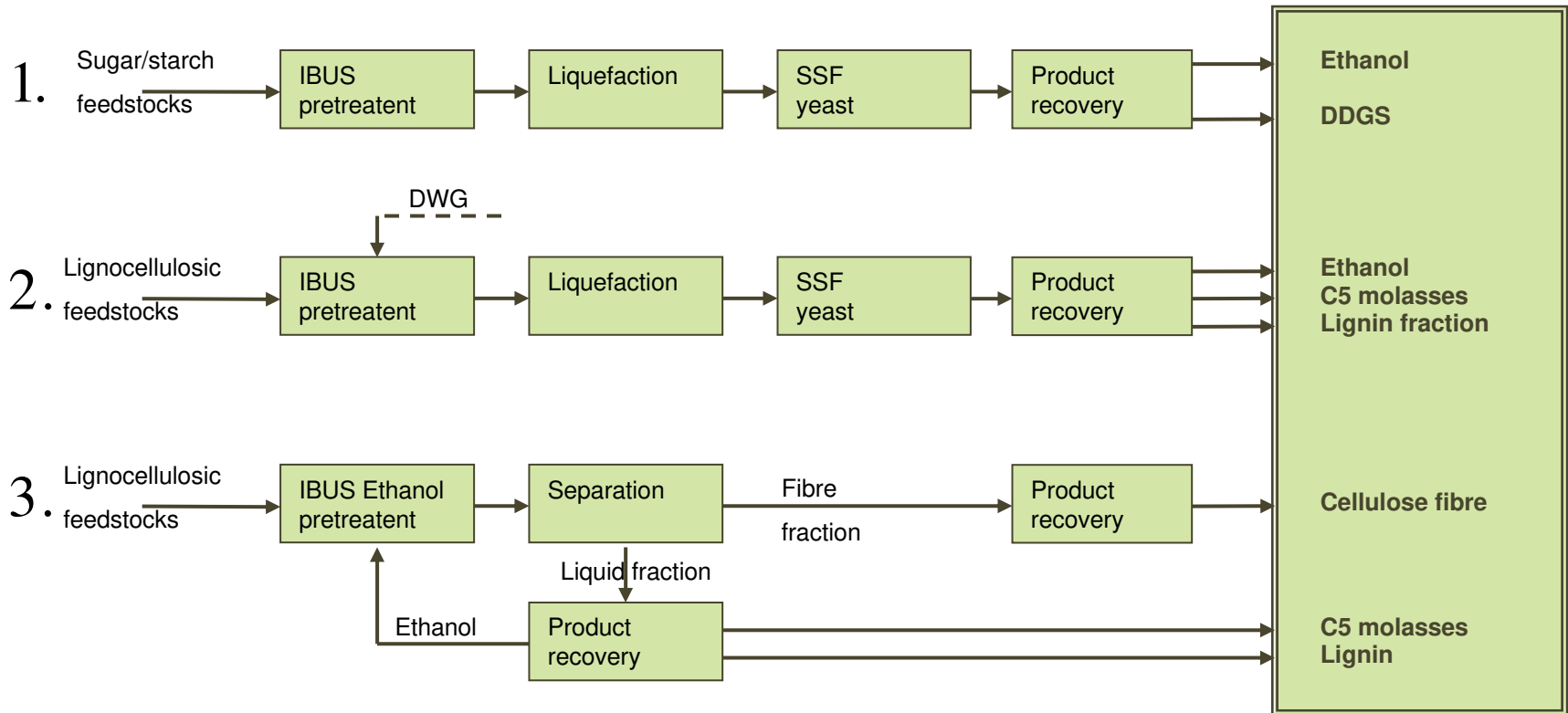

# IBUS – R & D

<b>Lab scale</b> 10 kg/h of straw	Pretreatment	Risoe National Laboratory
	Hydrolysis and fermentation	The Royal Veterinary and Agricultural University
<b>Pilot scale</b> 100 kg/h of straw	Particle generation, pretreatment, liquefaction, fermentation, product recovery	Dong Energy A/S
<b>Pilot scale</b> 1000 kg/h of straw	Particle generation, pretreatment	Dong Energy A/S
<b>Process Innovation</b>	From field to fuel	Holm Christensen Biosystemer ApS
<b>Demonstration plant</b> 4 t/h of straw d.m. + 4 t/h of grain d.m.	Fully integrated IBUS plant located at one of Dong Energy's Power Plants (Kalundborg) Planned start of production: ultimo 2009	Inbicon A/S



# Content

- IBUS technology
- **Demonstration**
- Commercialisation

## Feedstock development

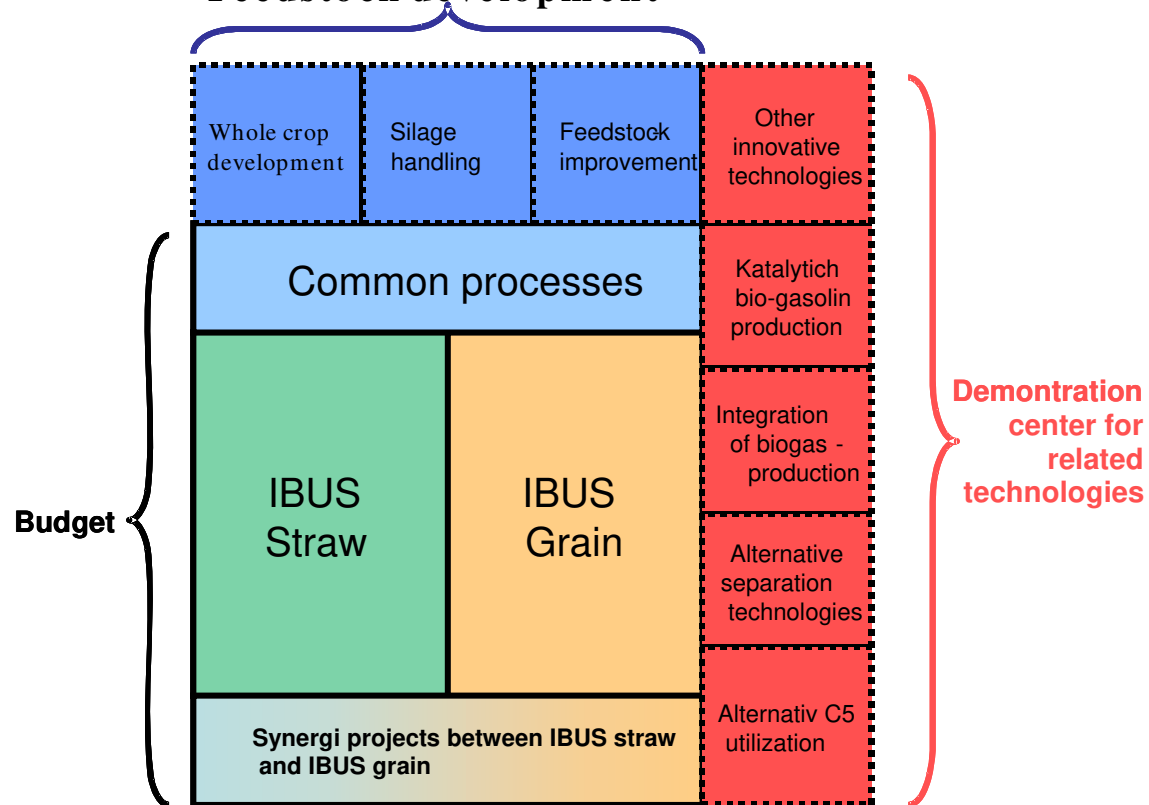

# Demonstration concept

## Synergies between straw and grain

**Large international potential for technology integrating 1. and 2nd generation ethanol**

**Examples of synergies at demo-plant:**

- DWG as feedstock in the straw process
- Surplus of energy from the straw process goes to the grain process
- Water and energy exchange between the two processes
- Optimization of field to ethanol plant (whole crop handling)
- Compound feed production based on DWG and C5 molasses
- Integration of main processes
- Improvement of feedstocks
- Logistic and marketing

# Kalundborgs industrielle symbiose

The existing symbiose is extended with biofuel and by-products

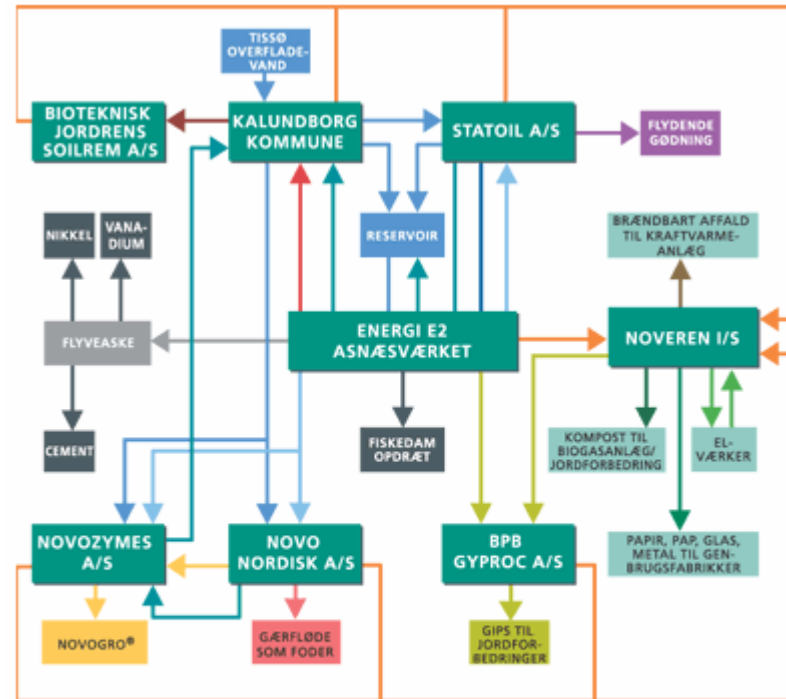

ASKE	VAND	DAMP	KØLE-VAND	SPILDE-VAND	GIPS	FLYDENDE GODNING	REST-VARME	GÆRFLODE
NOVOGRO®	SLAM	ANDET	ØVRIGT AFFALD	PAPIR, PAP, GLAS, METALLER	E.L.	BRÆNDBART AFFALD	KOMPOST BIO-MATERIALE	





# Kalundborg

**Powerplant, refinery and enzyme producer**

Statoil

Asnæs Power Plant

World class demo-center for 2<sup>nd</sup> generation bioethanol

Novo Nordisk  
Novozymes





# Kalundborg New Synergy

Bioethanol til Statoil  
Syngas / H<sub>2</sub> til Statoil

## Asnæsværket

Enzymes from Novozymes

Rawmaterials from  
and feed to DLG

Process steam → - 50% CO<sub>2</sub>-emission  
Solid biofuel → Substitute coal  
Process water to deSO<sub>x</sub>-plant  
District heat to city  
Harbor facilities



# Asnæs PP - Integration

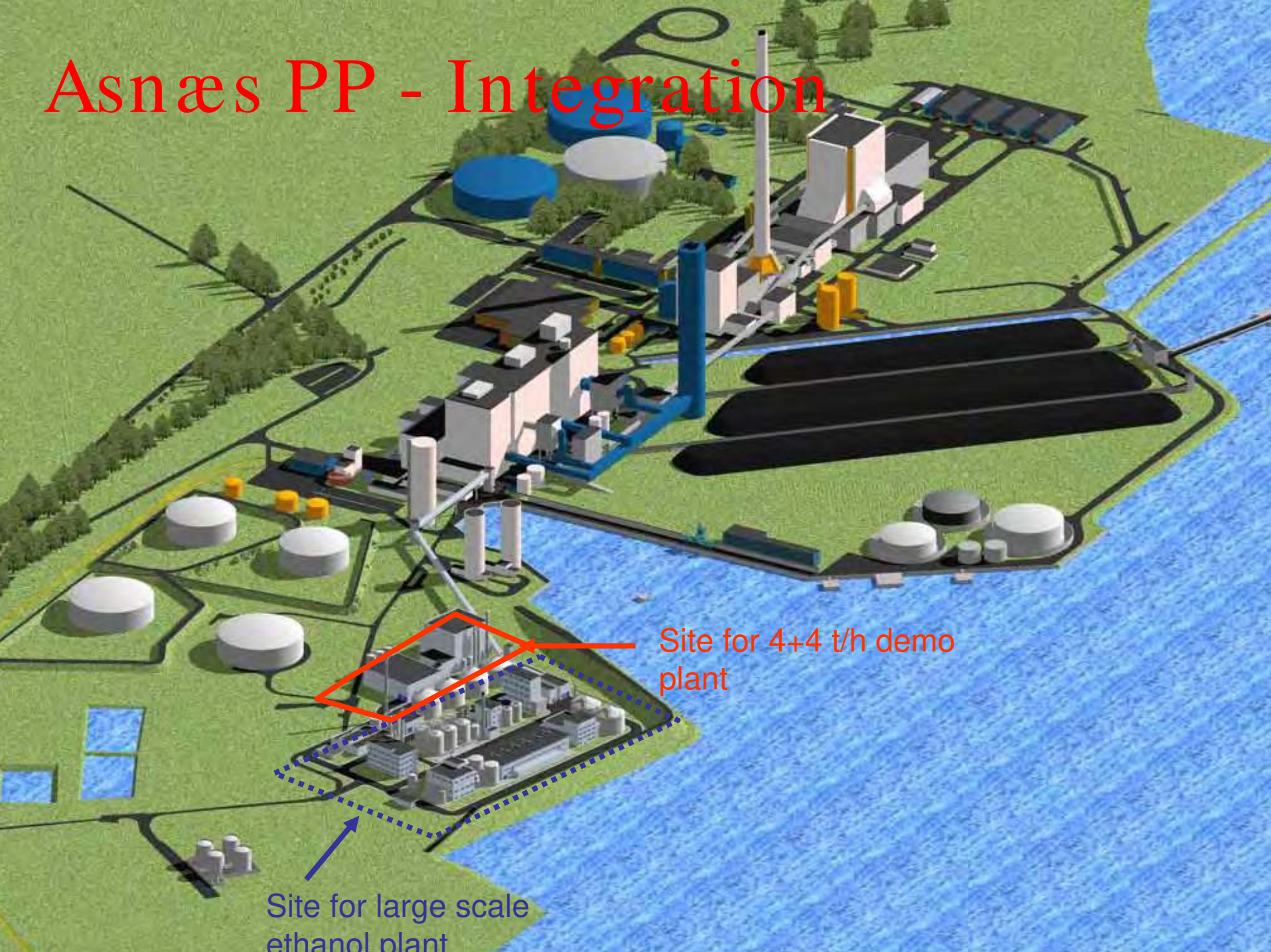

Site for 4+4 t/h demo plant

Site for large scale ethanol plant

# Content

- IBUS technology
- Demonstration
- Commercialisation

# Demo plant

- Goal: Production before UN Copenhagen Climate Summit November 2009
- Capacity: 4 ton straw + 4 ton grain (budget ca. 40 mill US)
- Partners (Inbicon, Dong Energy, Novozymes, Statoil and Danish Farmers COOP)
- Technology: (IBUS technology - integration of 1. and 2. bio ethanol connectd to Power Plant)



# Commercialization

- Technology company – new investors
- Verification of technology (scale-up, reliability, demonstration of yields, environmental impact and feasibility)
- Partners: (North America, China and Brazil)
- Overseas demonstration projects
- Contracts

# Success criteria

- Best economy  
(energy efficiency, enzymes, capital cost and value of by-products)
- Market share  
(the right partners and fast deployment)

Thank you for your attention



# Long-term biofuels scenarios: preliminary results from REFUEL – A European Road Map for Biofuels

Henrik Duer

COWI A/S, Denmark





# Contents

1. Introduction
2. REFUEL objectives
3. Resource base assessment
4. Biofuels mix development
5. Barriers identified
6. Conclusions

# 1. Introduction

## Biofuels production in Europe 1991-2005

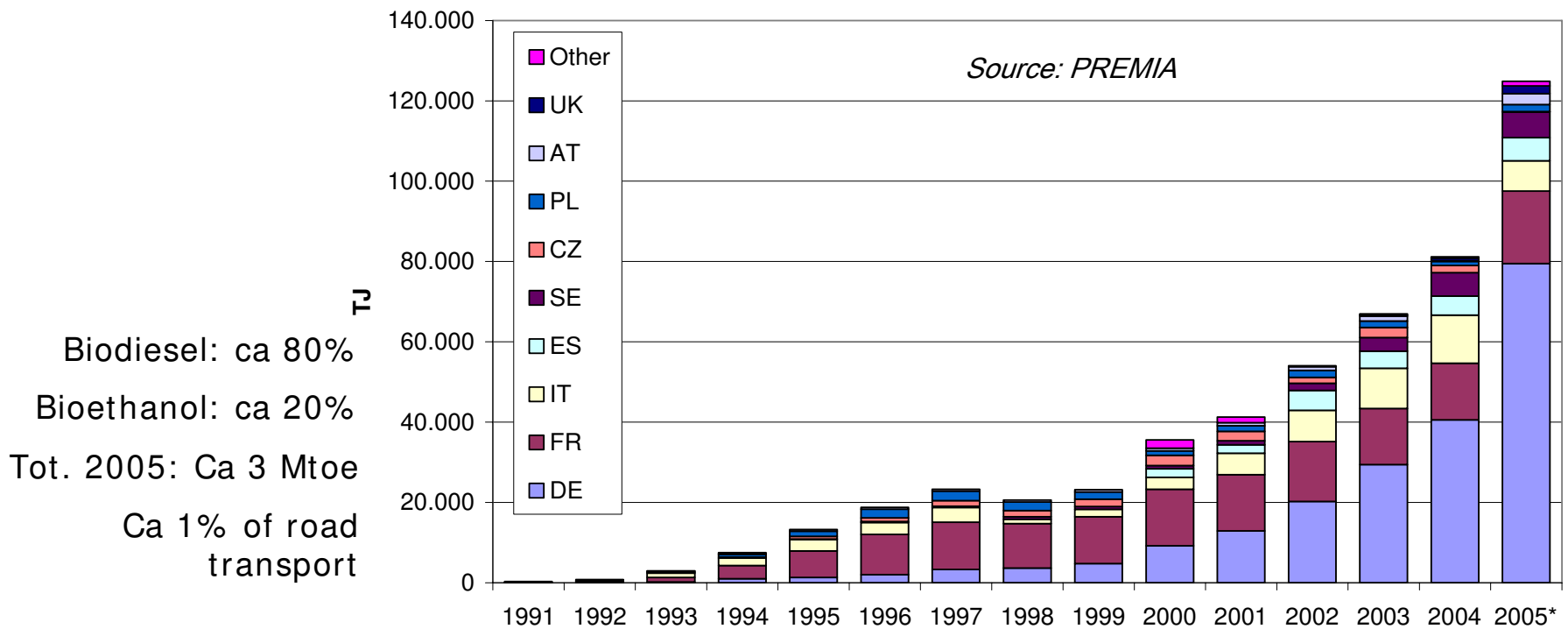

# Development

Now 1<sup>st</sup> generation in rapid deployment:

- Major investments in biodiesel, bioethanol
- Long-term feedstock availability
- Sustainability, GHG performance?

Future biofuels mix:

- Advanced biofuels (FT-diesel, advanced bioethanol)
- Remaining 1<sup>st</sup> generation?

*Central question: what can we expect from biofuels in the long run?*

# Technological learning and land scarcity

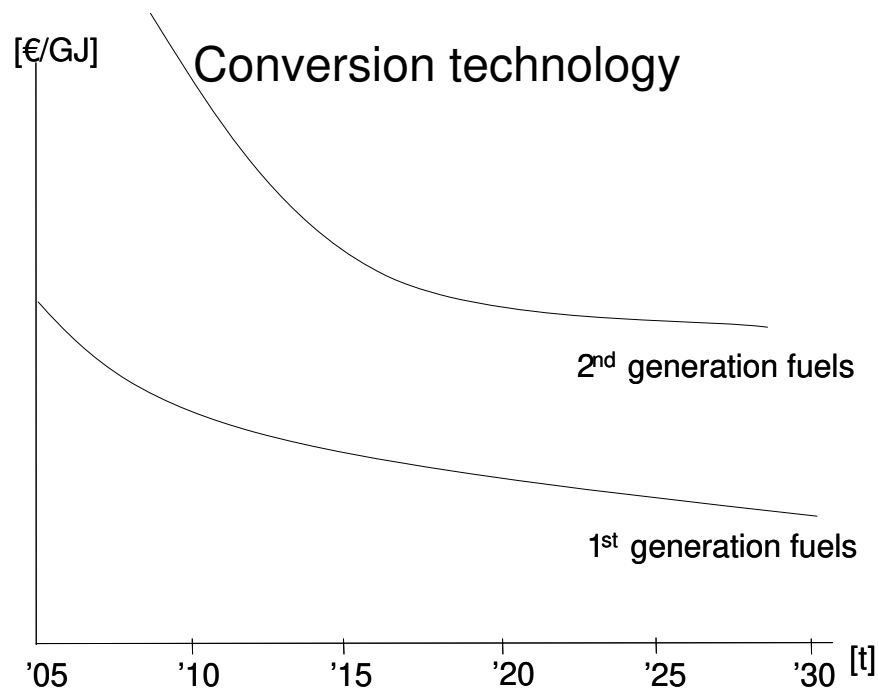
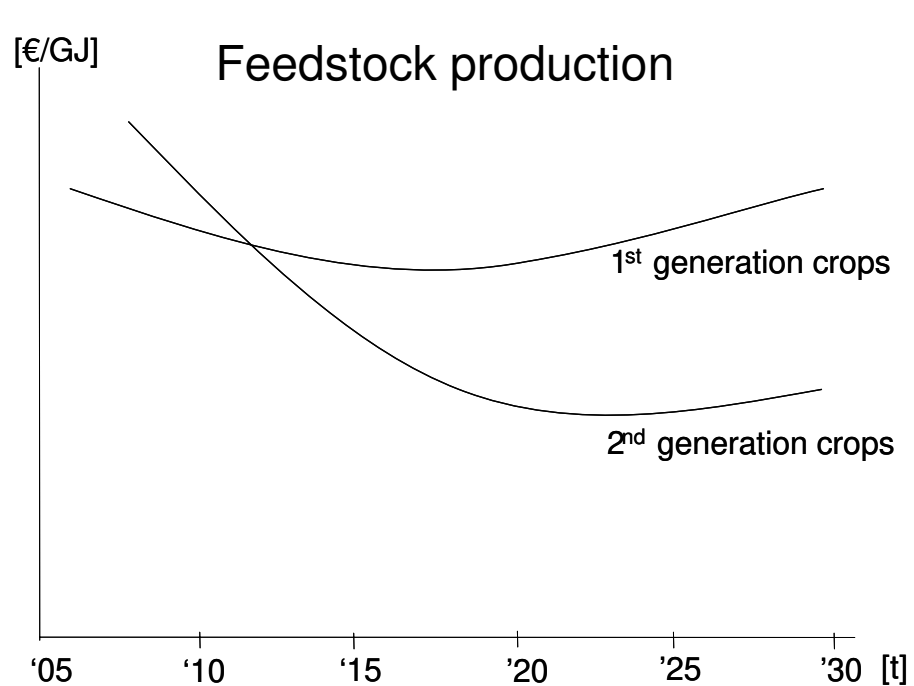

## 2. REFUEL, main objectives

*To develop an ambitious, yet realistic road map  
for an effective deployment of biofuels  
until 2030 in the EU25+*

- ***The destination:*** Ambitious, but realistic biofuels targets
- ***The route:*** the least-cost biofuel mix and biofuel chains
- ***The purpose of the journey:*** impact assessments on GHG, SoS, socio-economics, stationary sector, environment
- ***At the wheel:*** key stakeholders, technological innovation needed, learning, options and barriers
- ***Paving the way:*** related policies on energy, agri, technology, measures (incentives, obligations)...

# 3. Resource assessment

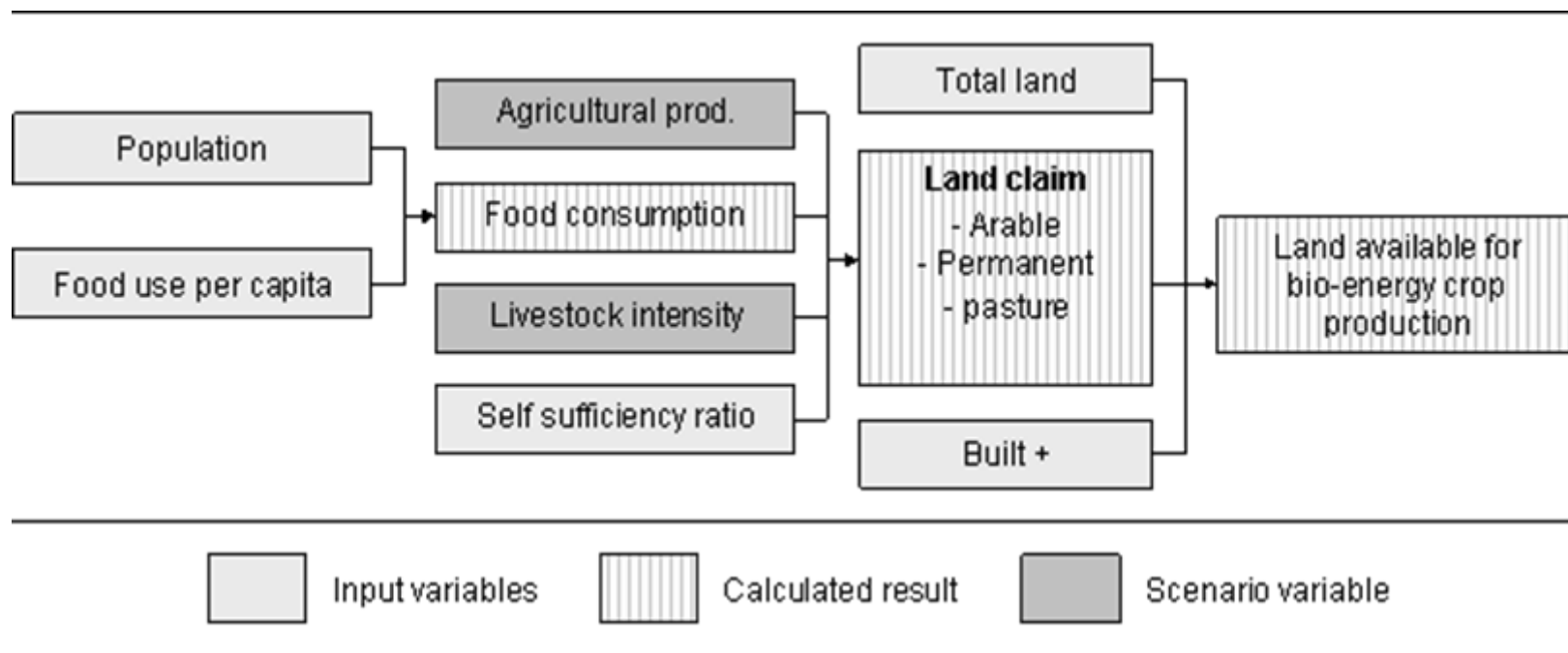



# Land suitability to crops

- Priority for food etc.
  - Demand scenarios
  - Agric. production
  - Natura2000
- No drastic land use changes

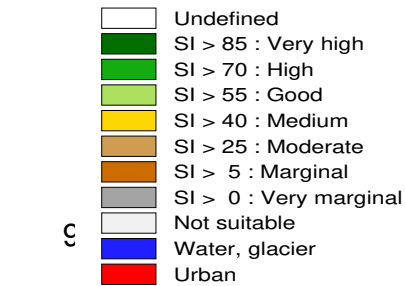

million ha

9  
8  
7  
6  
5  
4  
3  
2  
1

**Land suitability for wheat, sugar beet**

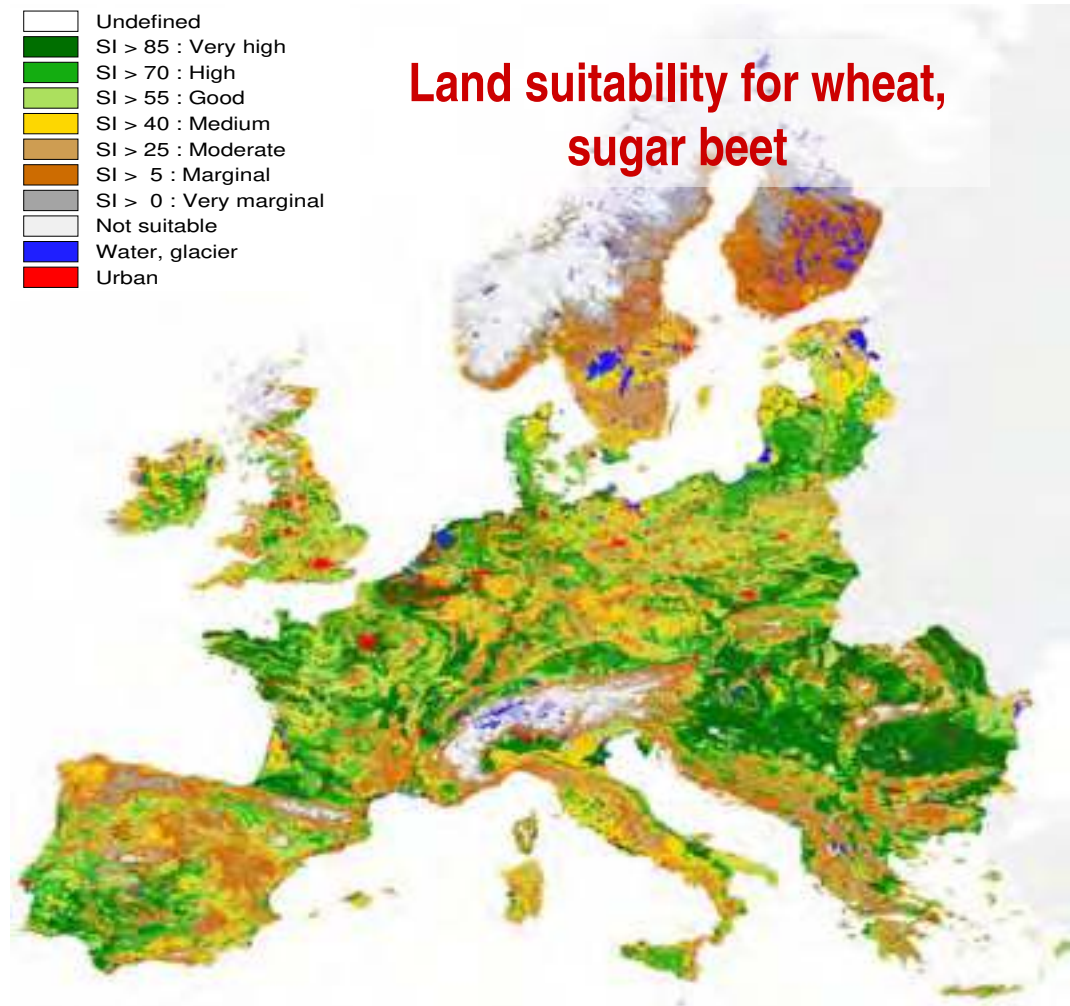

T+

# Some preliminary results: Feedstock

## Total land potential if used for perennial grasses:

EU27:

1/10 of prim. energy demand  
1/3 of gasoline/diesel demand

EU plus Ukraine:

1/6 of EU 2030 prim. energy demand  
Or half of gasoline/diesel dem.

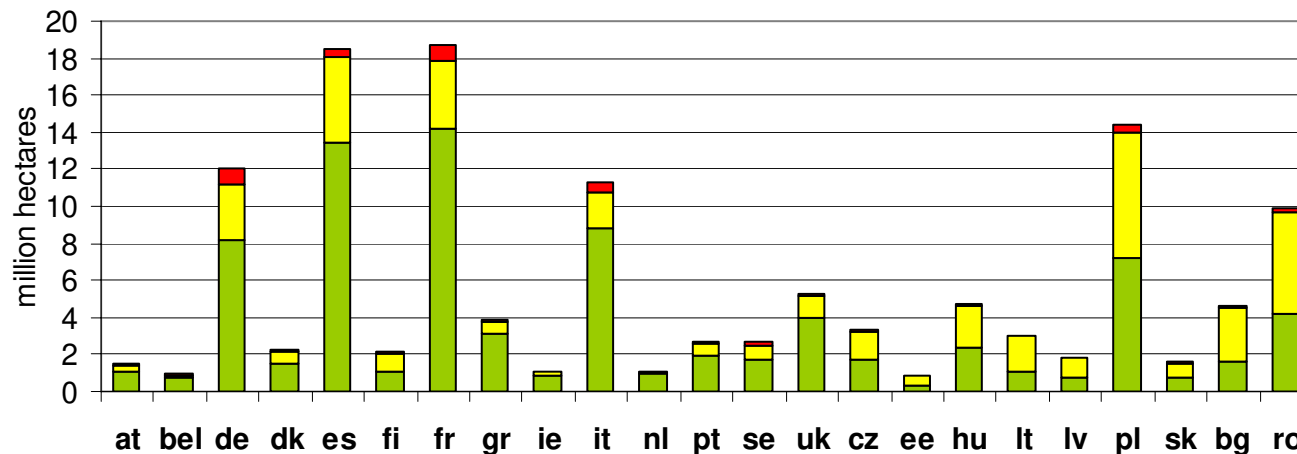
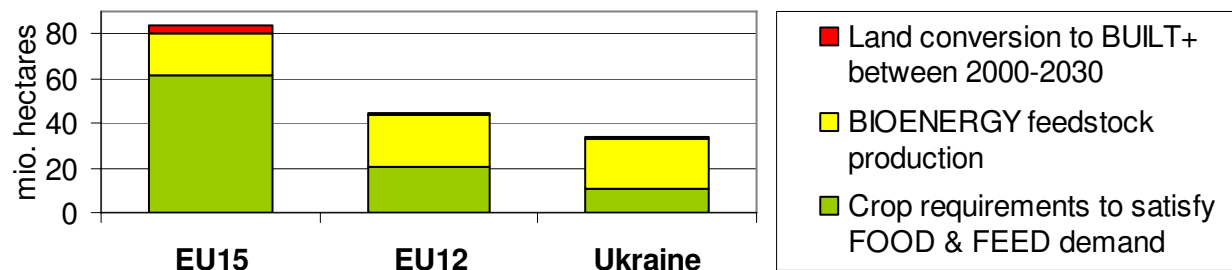



## Sensitivities

More conservative:

- More organic farming
- Less rapid productivity developments in CEEC

*Ca 10% less land potential*

More optimistic:

- GMO's
- Faster convergence in CEEC

*Ca 15% more land potential*

Nota bene:



**Costs, not prices**

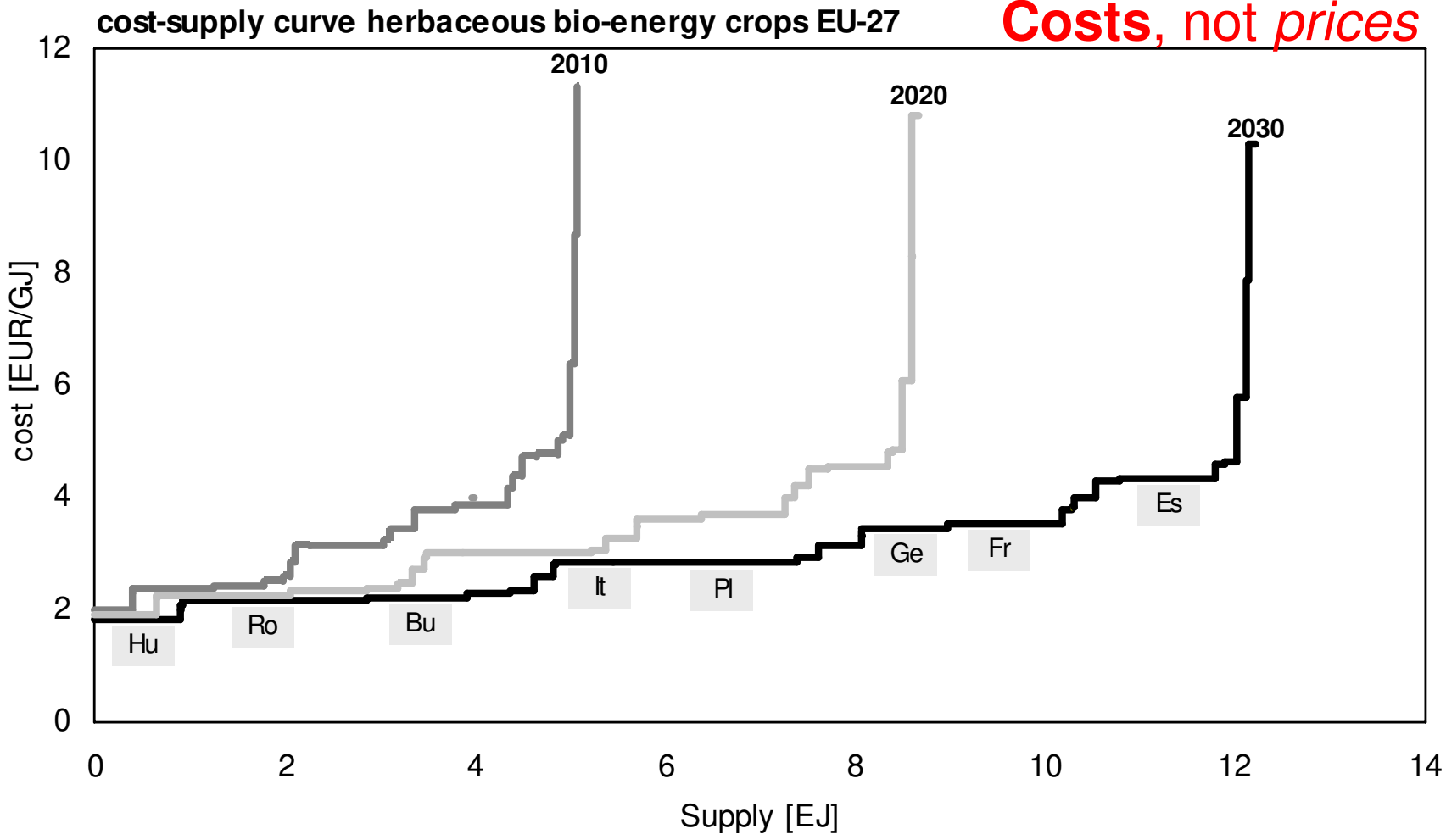

## 4. Biofuel mix assessment

- Least-cost biofuels mix over full chain:  
Production, transport, conversion, distribution, end-use (*Biotrans* model)
- 1<sup>st</sup> and 2<sup>nd</sup> generation biofuels
- Crops, residues etc.
- Within-EU trade, imports
- Key issue: Learning -
  - In feedstock production
  - In conversion

# 2005 biofuel costs built-up in Biotrans

2005

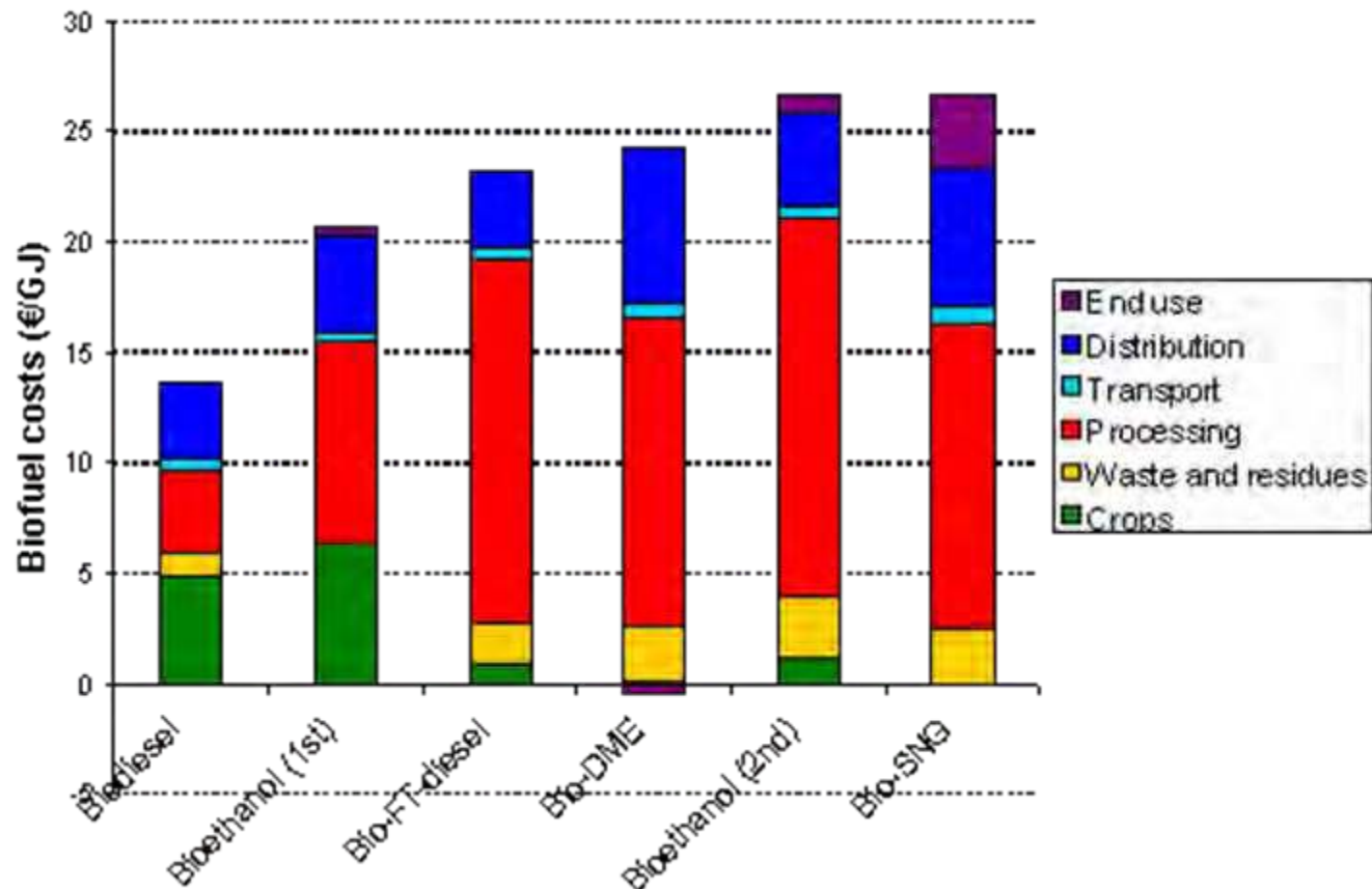

# Preliminary results: Biofuel consumption

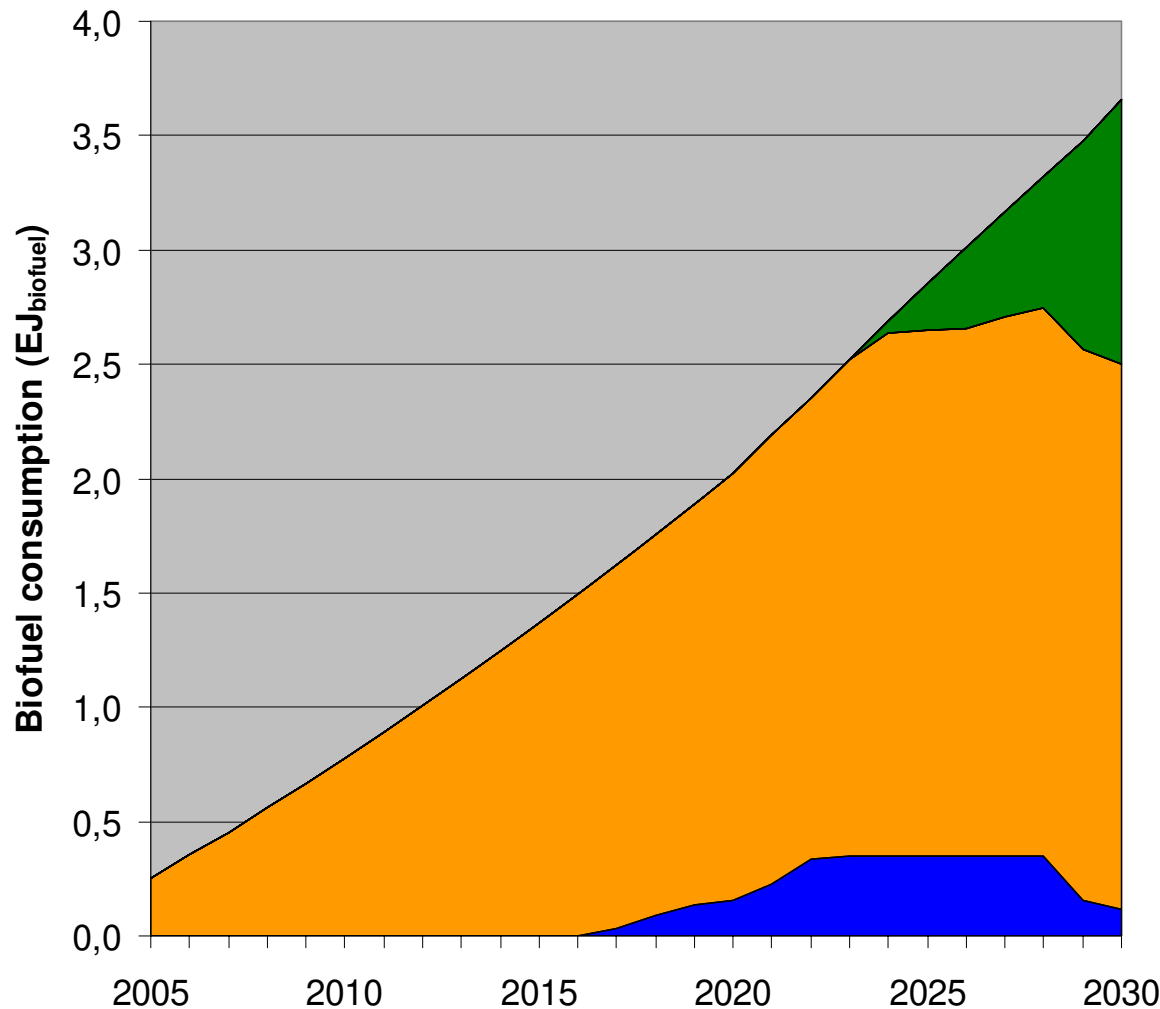

25% target (2030)  
imports allowed

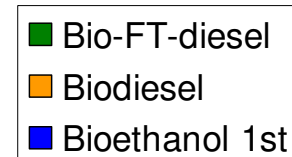

Diesel substitutes  
dominate

Late intro of 2<sup>nd</sup> gen.

Brazilian Ethanol

Avg GHG: 25 kg/GJ

# Preliminary results: Feedstock base

25% target (2030)  
imports allowed

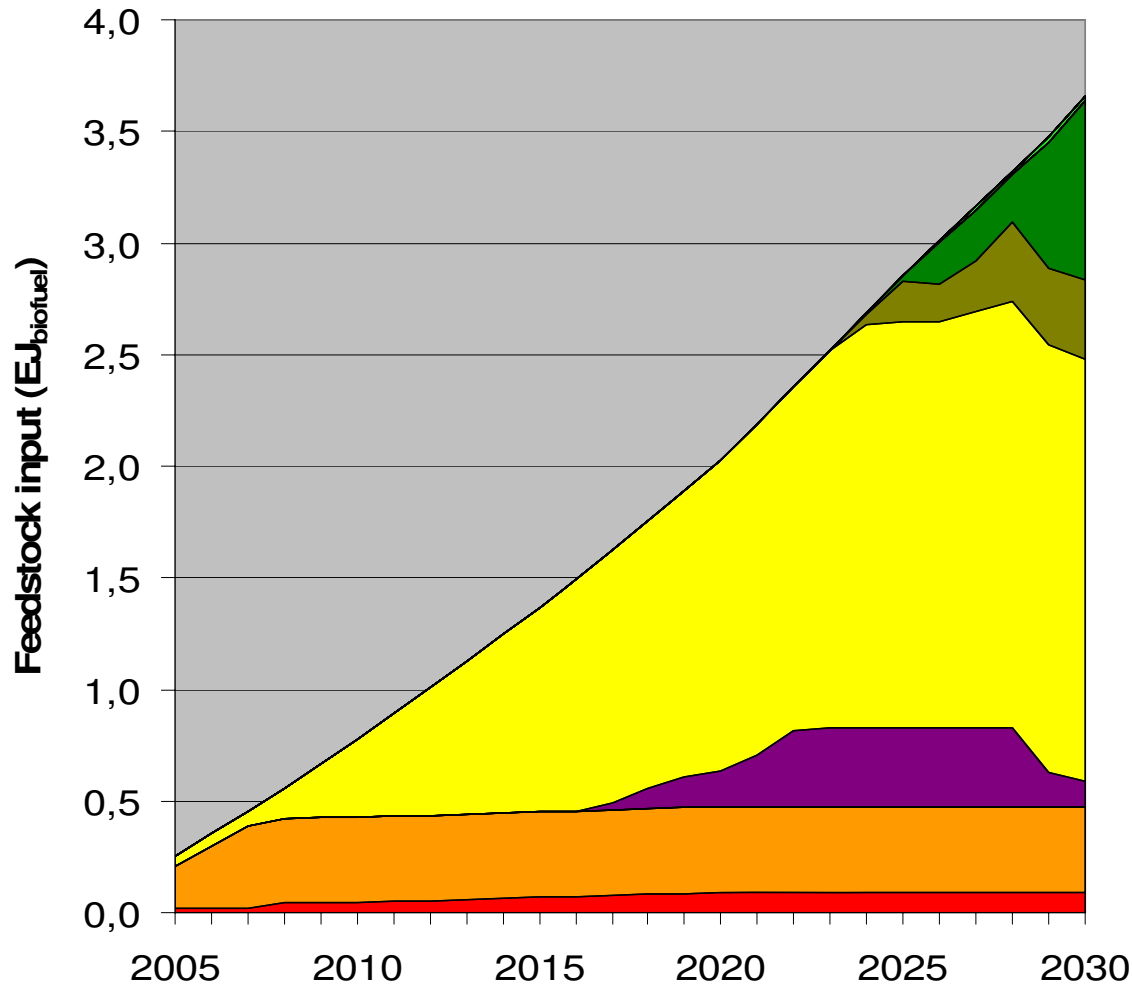

- Grassy crops
- Woody crops
- Wood processing residues
- Oil crops
- Brazilian import ethanol
- Palm oil import
- Used fats/oils

Diesel substitutes  
dominate

Late intro of 2<sup>nd</sup> gen.

Brazilian Ethanol



# Aggregated cost build-up

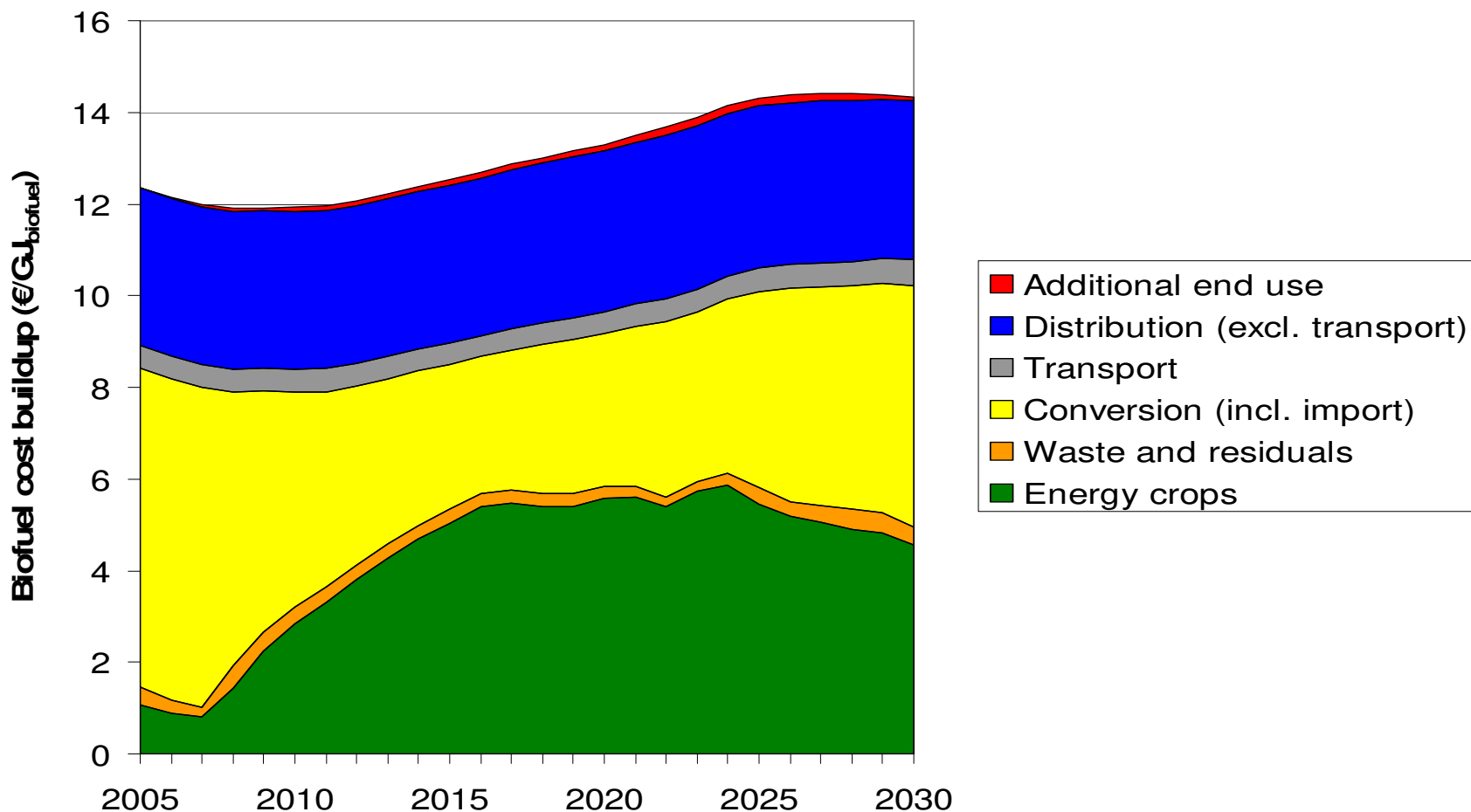

## Other scenarios and policy options:

### *No imports:*

- Earlier introduction of 2nd generation (2013)
- Higher average fuel costs until 2025
- Better GHG profile: < 20 g/MJ biofuel

### *Lower biofuels ambitions (15% in 2030):*

- No introduction of 2nd generation
- Lower average fuel costs
- Worse GHG profile: > 30 g/MJ

### *Impact of 2<sup>nd</sup> generation biofuel obligation by 2020:*

- Higher costs in 2015-2025, lower costs afterwards?
- Better GHG performance



## Further work

### *Assessment of biofuel growth limitations*

- Adoption rates to new crops
- Competition for ligno feedstock
  - RES-Electricity and Heat production
  - CHP is attractive
  - Assessment of potential and effects in Peep model

### *Implications of other policies*

- Specific targets for diesel and gasoline substitutes?
- Active AGRI policy?
- (internal and external) trade policy?

## 5. Barriers identified

Basic fact that:

- the process is politically and not market driven

Four key barriers identified by stakeholders:

1. No clear strategy on how to achieve the biofuel targets
2. There is no common market for biofuels
3. There is no common technical standards
4. Limited resources of land

We address issues related

## 6. Conclusions

- Rapid development of biofuels in EU: need for robust long-term strategy
- Significant land potential available (Central and East)
- Least-cost: 1<sup>st</sup> general may dominate long
- Policy driven
- For development of best GHG-performing biofuels:
  - Specific incentives needed
  - Adequate incentives and policies will be crucial

Thank you

Further information and updates:

[www.refuel.eu](http://www.refuel.eu)

[info@refuel.eu](mailto:info@refuel.eu)

[hdu@cowi.dk](mailto:hdu@cowi.dk)

[londo@ecn.nl](mailto:londo@ecn.nl)

# UpWind

The logo for the UpWind project, featuring a stylized orange wind turbine with three blades and a central hub, positioned to the right of the main title.

*A Wind Research Project under the 6th Framework Programme*

**Program Manager  
Peter Hjuler Jensen  
RISØ National Laboratory  
Technical University of Denmark**



# Outline

1. Background
2. Global development of Wind Energy
3. Presentation of UpWind
4. UpWind - First year results
5. Questions and discussion



# Installed Wind Power in the World

- Annual and Cumulative -

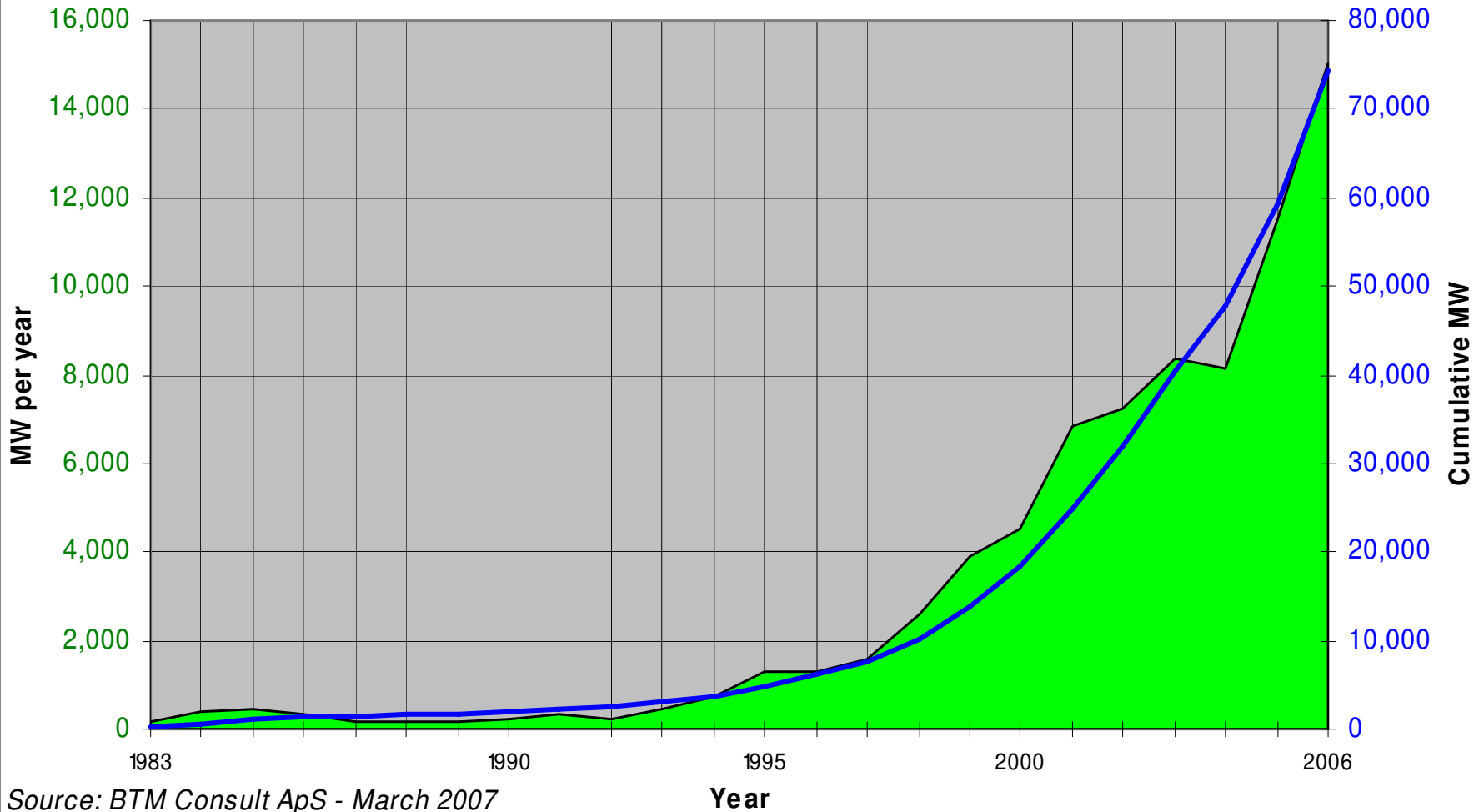

Source: BTM Consult ApS - March 2007



SIXTH FRAMEWORK PROGRAMME



# Global Wind Power Status

Cumulative MW by end of 2000, 2003 & 2006

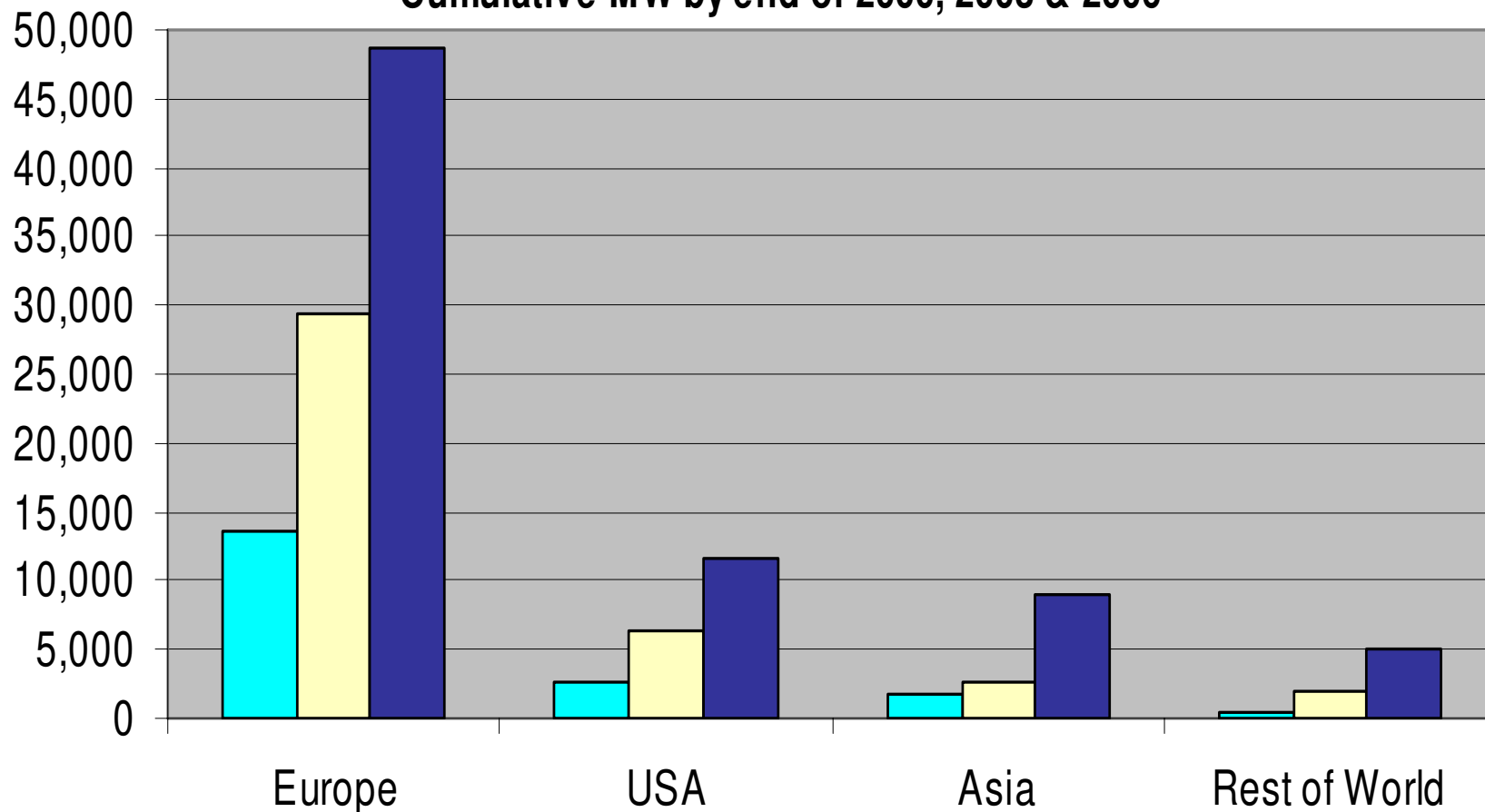

Source: BTM Consult ApS - March 2007

■ 2000 (18,449 MW) ■ 2003 (40,301 MW) ■ 2006 (74,306 MW)





# Installed capacity in 2005 and 2006 (Americas)

	Installed MW 2005	Accu. MW 2005	Installed MW 2006	Accu. MW 2006
Argentina	1	31	0.0	31
Brazil	0	31	199.6	231
Canada	239	683	776	1,459
Costa Rica	0	79	0	79
Mexico	0	3	83	86
USA	2,431	9,181	2,454	11,635
Other Americas	0	54	2	56
<b>Total Americas</b>	<b>2,671</b>	<b>10,062</b>	<b>3,515</b>	<b>13,577</b>

Source: BTM Consult ApS - March 2007



# Installed capacity in 2005 and 2006 (Asia)

	Installed MW 2005	Accu. MW 2005	Installed MW 2006	Accu. MW 2006
P.R. China	498	1,264	1,334	2,588
India	1,388	4,388	1,840	6,228
Taiwan	60	72	46	118
Rest of Asia: Indonesia, N. Korea, Malaysia, Philippines, Thailand, Vietnam, etc.	25	28	0.0	28
<b>Total South &amp; East Asia</b>	<b>1,971</b>	<b>5,753</b>	<b>3,220</b>	<b>8,963</b>

Source: BTM Consult ApS - March 2007



# Installed capacity in 2005 and 2006 (Europe)

	Installed MW 2005	Accu. MW 2005	Installed MW 2006	Accu. MW 2006
Austria	218	820	146	966
Belgium	71	177	45	222
Denmark	22	3,087	14	3,101
Finland	6	85	4	89
France	389	775	810	1,585
Germany	1,808	18,445	2,233	20,652
Greece	118	705	157	862
Ireland (Rep.)	159	498	250	748
Italy	452	1,713	417	2,118
Luxembourg	0	12	0	12
Netherlands	154	1,221	351	1,557
Norway	117	275	53	328
Poland	10	65	105	170
Portugal	502	1,087	629	1,716
Spain	1,764	10,027	1,587	11,614
Sweden	76	554	62	571
Switzerland	3	11	0	11
Turkey	0	20	56	76
UK	447	1,336	631	1,967
Rest of Europe: Other East European and Baltic countries.	57	132.1	130.6	262.7
<b>Total Europe</b>	<b>6,372</b>	<b>41,044</b>	<b>7,682</b>	<b>48,627</b>

Source: BTM Consult ApS - March 2007



# Installed capacity in 2005 and 2006 (Rest of World)

	<b>Installed MW 2005</b>	<b>Accu. MW 2005</b>	<b>Installed MW 2006</b>	<b>Accu. MW 2006</b>
Australia	296	717	79	796
Japan	168	1,159	298	1,457
New Zealand	0	167	3	170
Pacific Islands	0	5	6	11
South Korea	20	89	106	194
<b>Total OECD-Pacific</b>	<b>484</b>	<b>2,137</b>	<b>491</b>	<b>2,628</b>
Egypt	34	180	51	231
Morocco	10	64	58	122
Tunisia	0	28	0	28
Rest of Africa: Algeria, Cape Verde, Ethiopia, Libya, South Africa, etc.	0	6	0	6
<b>Total Africa</b>	<b>44</b>	<b>278</b>	<b>109</b>	<b>386</b>
Middle East: Jordan, Iran, Iraq, Israel, Saudi Arabia, Syria, etc. (excl. Egypt)	0	101	0	101
Transition Economies: incl. Russia, White Russia, Ukraine, Uzbekistan, Kazakstan, etc.	0	23.7	0.0	23.7
<b>Total other continents and areas:</b>	<b>0</b>	<b>124.4</b>	<b>0.0</b>	<b>124.4</b>

Source: BTM Consult ApS - March 2007



# Installed offshore wind power in the World

	Installed MW 2005	Accu. MW 2005	Installed MW 2006	Accu. MW 2006
Country				
Denmark	0	397.9	0	397.9
Ireland	0	25	0	25
The Netherlands	0	18.8	108	126.8
Sweden	0	23.3	0	23.3
UK	90	214	90	304
<b>Total capacity - World</b>	<b>90</b>	<b>679</b>	<b>198</b>	<b>877</b>

Source: BTM Consult ApS - March 2007

## The 10 largest markets in 2006 (Annual MW)

Country	2004	2005	2006	Share %	Cum. Share %
USA	389	2,431	2,454	16.3%	16%
Germany	2,054	1,808	2,233	14.9%	31%
India	875	1,388	1,840	12.3%	43%
Spain	2,064	1,764	1,587	10.6%	54%
P.R. China	198	498	1,334	8.9%	63%
France	138	389	810	5.4%	68%
Canada	123	239	776	5.2%	73%
UK	253	447	631	4.2%	78%
Portugal	274	502	629	4.2%	82%
Italy	357	452	417	2.8%	85%
<b>Total</b>	<b>6,725</b>	<b>9,918</b>	<b>12,711</b>		
Percent of World	82.5%	85.9%	84.7%		

Source: BTM Consult ApS - March 2007



# Growth rates in the Top-10 markets

	Accu. end 2003	Accu. end 2004	Accu. end 2005	Accu. end 2006	Growth rate 2005-2006 %	3 years average %
Country						
Germany	14,612	16,649	18,445	20,652	<b>12.0%</b>	12.2%
USA	6,361	6,750	9,181	11,635	<b>26.7%</b>	22.3%
Spain	6,420	8,263	10,027	11,614	<b>15.8%</b>	21.8%
India	2,125	3,000	4,388	6,228	<b>41.9%</b>	43.1%
Denmark	3,076	3,083	3,087	3,101	<b>0.5%</b>	0.3%
P.R. China	571	769	1,264	2,588	<b>104.7%</b>	65.5%
Italy	922	1,261	1,713	2,118	<b>23.6%</b>	31.9%
UK	759	889	1,336	1,967	<b>47.2%</b>	37.3%
Portugal	311	585	1,087	1,716	<b>57.9%</b>	76.8%
France	274	386	775	1,585	<b>104.6%</b>	79.4%
<b>Total "Ten"</b>	<b>35,431</b>	<b>41,634</b>	<b>51,303</b>	<b>63,203</b>	<b>23.2%</b>	<b>21.3%</b>

Source: BTM Consult ApS - March 2007



# The 10 largest markets by end of 2006 (cumulative MW)

Country	2004	2005	2006	Share %	Cum. Share %
Germany	16,649	18,445	20,652	27.8%	28%
USA	6,750	9,181	11,635	15.7%	43%
Spain	8,263	10,027	11,614	15.6%	59%
India	3,000	4,388	6,228	8.4%	67%
Denmark	3,083	3,087	3,101	4.2%	72%
P.R. China	769	1,264	2,588	3.5%	75%
Italy	1,261	1,713	2,118	2.9%	78%
UK	889	1,336	1,967	2.6%	81%
Portugal	585	1,087	1,716	2.3%	83%
France	386	775	1,585	2.1%	85%
<b>Total</b>	<b>41,634</b>	<b>51,303</b>	<b>63,203</b>		
Percent of World	86.9%	86.4%	85.1%		

Source: BTM Consult ApS - March 2007





# Size of commercial wind turbines at first market introduction

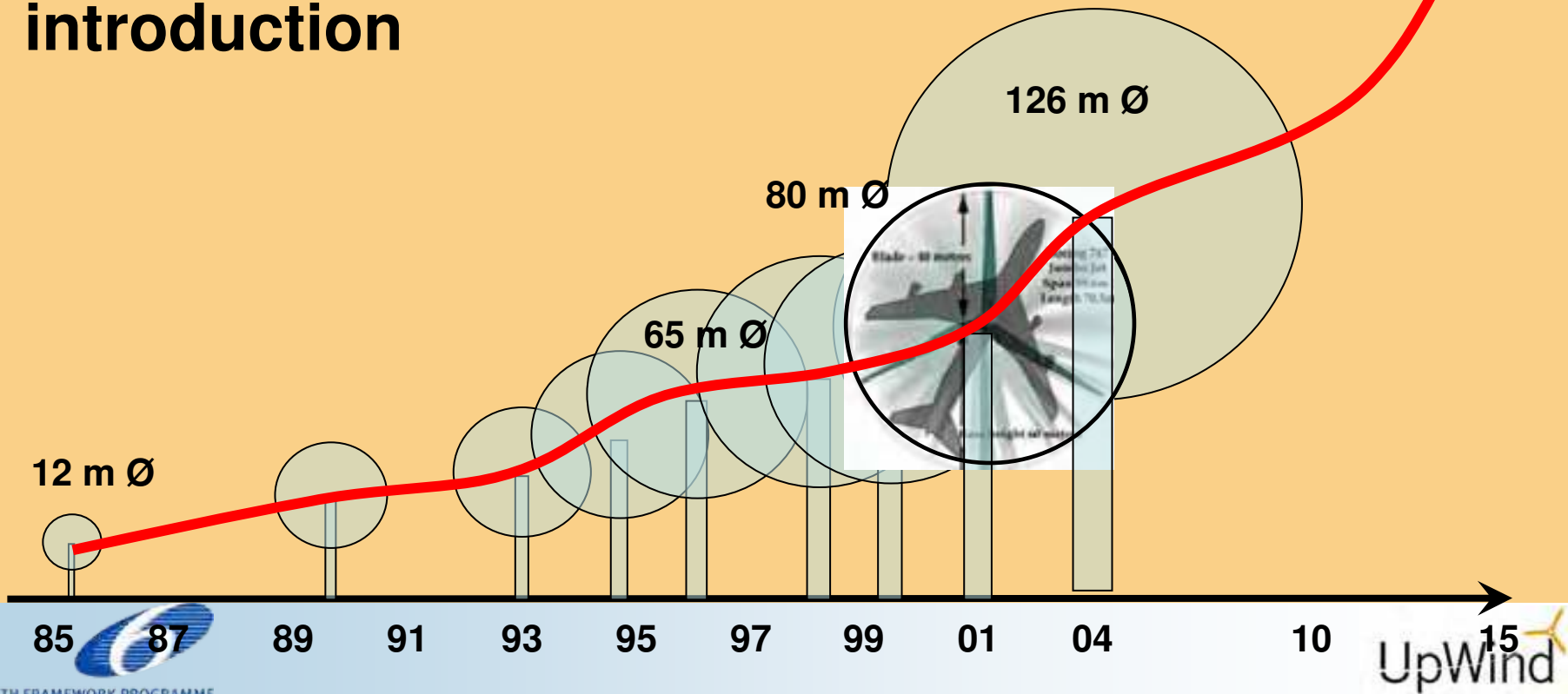

## Global Average Annual WTG in kW

Source: BTM Consult ApS - March 2007

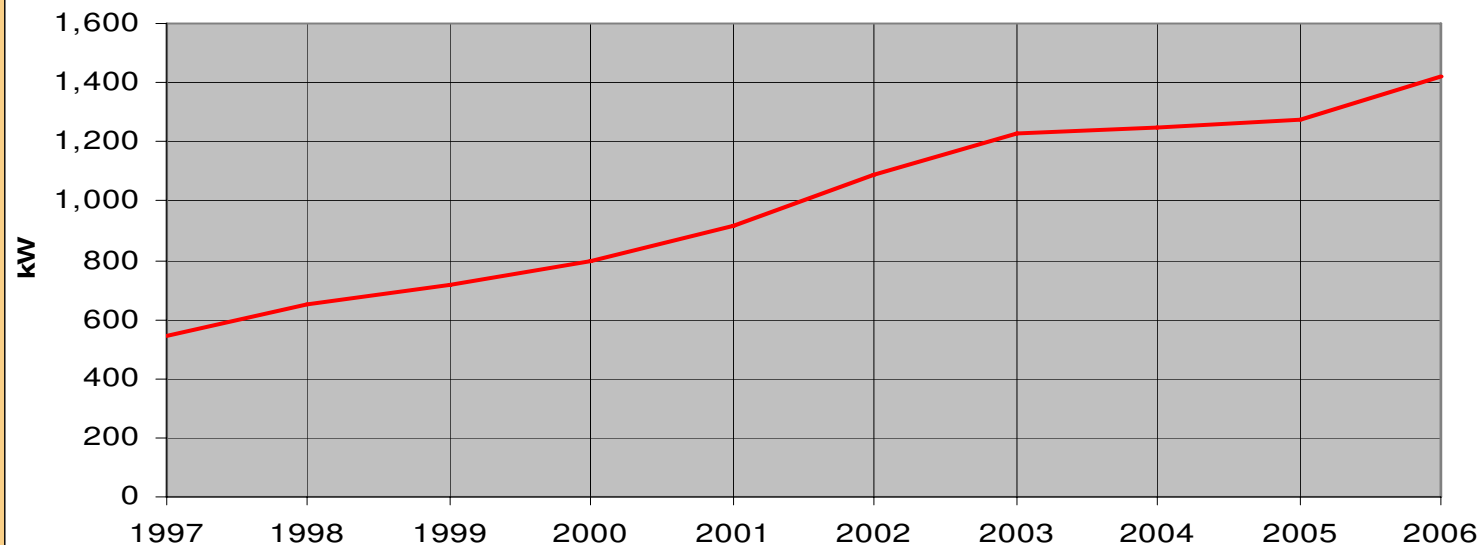

Year	China	Denmark	Germany	India	Spain	Sweden	UK	USA
2002	709	1,443	1,397	553	845	1,112	843	893
2003	726	1,988	1,650	729	872	876	1,773	1,374
2004	771	2,225	1,715	767	1,123	1,336	1,695	1,309
2005	897	1,381	1,634	780	1,105	1,126	2,172	1,466
2006	931	1,875	1,848	926	1,469	1,138	1,953	1,667

Source: BTM Consult ApS - March 2007



## Segmentation of product sizes in 2004-2006

<b>Year</b>	<b>2004</b>	<b>2005</b>	<b>2006</b>
Total MW supplied	<b>8,508</b>	<b>11,338</b>	<b>16,007</b>
<b>Product (Size range)</b>	<b>% of total MW</b>		
"Small WTGs" <750 kW	5.4%	3.6%	2.4%
"One-MW " 750-1500 kW	50.9%	48.2%	43.3%
"Mainstream" 1501-2500 kW	42.8%	45.8%	49.9%
"Multi-MW Class" >2500 kW	0.9%	2.4%	4.3%
<b>Total</b>	<b>100.0%</b>	<b>100.0%</b>	<b>100.0%</b>

Source: BTM Consult ApS - March 2007



# Top-10 Suppliers in 2006

% of the total market 15,016 MW

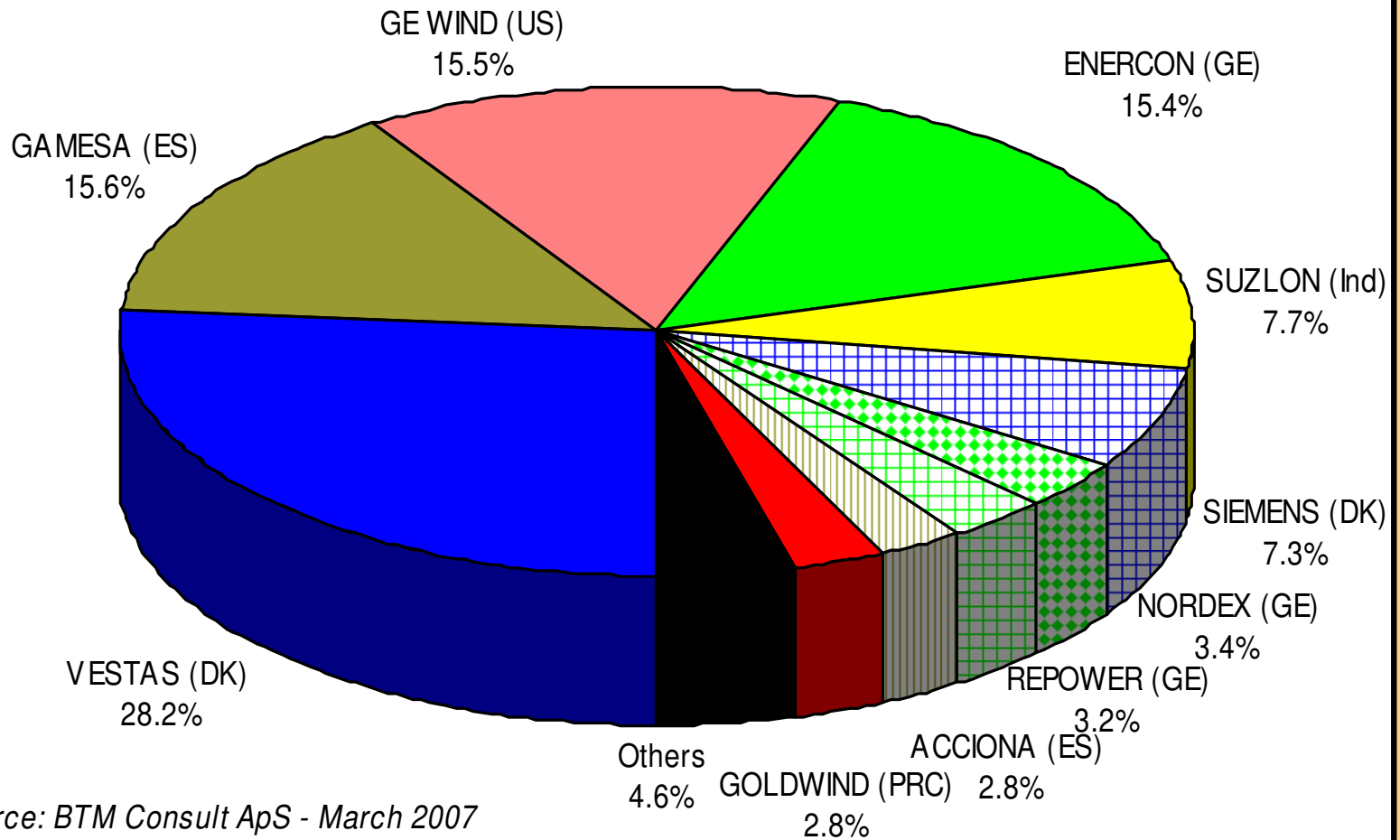

Source: BTM Consult ApS - March 2007



# UpWind Background

- ✧ ***UpWind: FP6 Integrated project***
- ✧ UpWind got Wind Energy back in the EU 6 Framework Energy Research program
- ✧ ***Result of AOT.'s EWEA Thematic Network(EU-project):***
  1. EWEA Research Strategy
  2. UpWind
  3. EWEA Strategic Research Agenda
  4. Technology Platform
- ✧ **Behind UpWind application were EAWE, EWEA and the partners (December 08 2004)**
- ✧ **Last minute saving of Wind Research Network in EU**
- ✧ **UpWind the glue/network and Lighthouse for EU R&D**



# The UpWind Project

## ***UpWind subtitle: Integrated Wind Turbine Design***

- ✧ Start date: 1 March 2006
- ✧ Duration: 60 months
- ✧ Costs: 22,340,000 EUR
- ✧ EC funding: 14,288,000 EUR
- ✧ Coordinator Risø National Laboratory, Denmark's Technical University



# Participants from Start

## 39 participants

- 11 EU countries
- 10 research institutes
- 11 universities
- 7 turbine & component manufacturers
- 6 consultants & suppliers
- 2 wind farm developers
- 2 standardization bureaus
- 1 branch organisation



# Partner's first year

- ✧ **39 partners in UpWind Consortium from start**
- ✧ Cener added (+1)
- ✧ Risø and DTU merged to DTU and RisøDTU (-1)
- ✧ Elsam sold to Dong Energy and Wattenfall (+1)
- ✧ INCO call added 3 new partners (+3):
  - ISM: Institute for Superhard Materials of the Nat. Academy of Science, Ukraine
  - IITB: Department of Civil Engineering of the Indian Inst. of Technology Bombay
  - CUMTB: China University of Mining and Technology Beijing
- ✧ **43 partners in UpWind Consortium May 2007**
- ✧ **Other potential partners: NREL USA**





# Objective - 1

**Develop and verify substantially improved design models and verification methods for wind turbine components, industry needs for future design and manufacture of:**

- 1 Very Large Wind Turbines**
- 2 More Cost Efficient Wind Turbines**
- 3 Offshore wind farms of several hundred MW**



# Objective - 2

- ✧ Consortium **integrates the disciplines and sectors needed** for the entire development chain of wind turbine technology
- ✧ 8 Scientific Work Packages – work programme
- ✧ 7 Integration Work Packages – work programme

## ***Upscaling***

- ✧ Today: WT up to  $P = 5$  MW and  $D = 120$  m
- ✧ Future: WT upscaling:  $P = 10$  MW and  $P = 20$  MW
- ✧ Develop methods to overcome showstoppers/optimize



# Organisation

## Classic and integrated research approach *Advanced Flexibel Modern Organisation*



# **Work Programme and Selected Results From first UpWind Year**



# WP 1A1 *Integrated design and standards*

- ✦ **Develop a reference wt** and reference site conditions for communication, integration and benchmarking of outcomes of the horizontal work packages;
- ✦ Development and definition of an **integral design method** to be applied in the real design of wind turbines; and
- ✦ Development **(pre)standards** for the formal international standardization effort.



# ***WP 1A2 Metrology***

- ↪ First year to create a list of **measured parameters** through communication with other work packages
- ↪ First **draft of list of parameters**
- ↪ The list has led to lively discussions between WPs
- ↪ The final list is being reported
- ↪ Next step reduce list and to
- ↪ Develop method's to reduce uncertainty



# ***WP 1A3 and WP 1B1***

## ***✧ Work Package 1A3 Education and Training***

- 1. Survey of existing infrastructures related to education and training*
- 2. Next step make a database for education and training*

## ***✧ Work Package 1B1 Innovative rotorblades***

- 1. Survey over **existing blade assembling methods***
- 2. Next step: select a assembling method and design a blade in two segments**



# Results from First Year 1B2 Transmission and conversion

↪ WP 1B2.a – “**Mechanical Transmission**”

↪ WP 1B2.b – “**Generators**”

↪ WP 1B2.c – “**Power Electronics**”





# Mechanical Transmission Modeling example

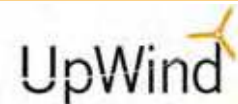
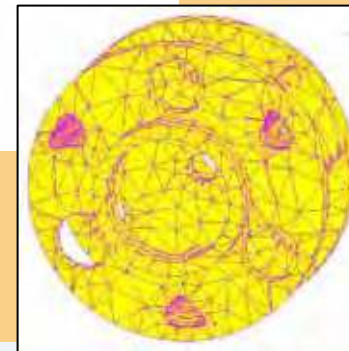
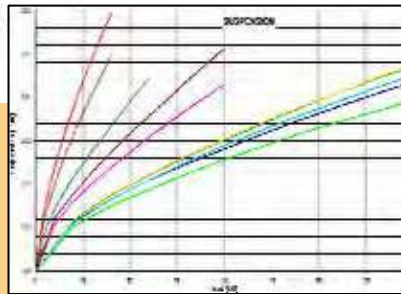
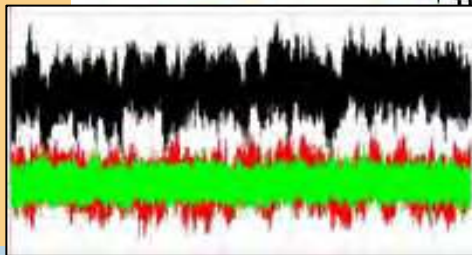
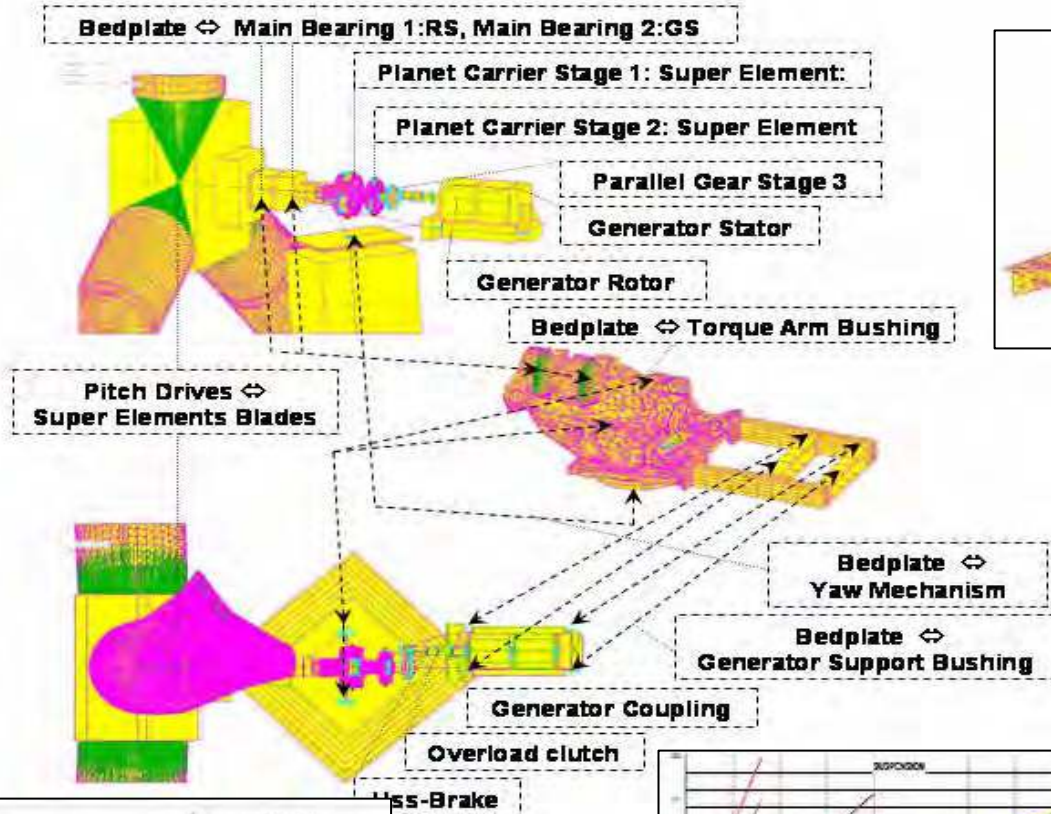
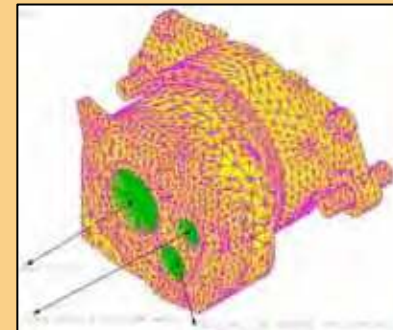
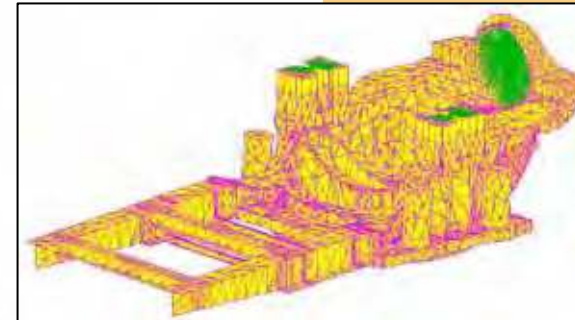

# Comparison of different generator systems

- 3MW wind turbine with the direct-drive and geared-drive -

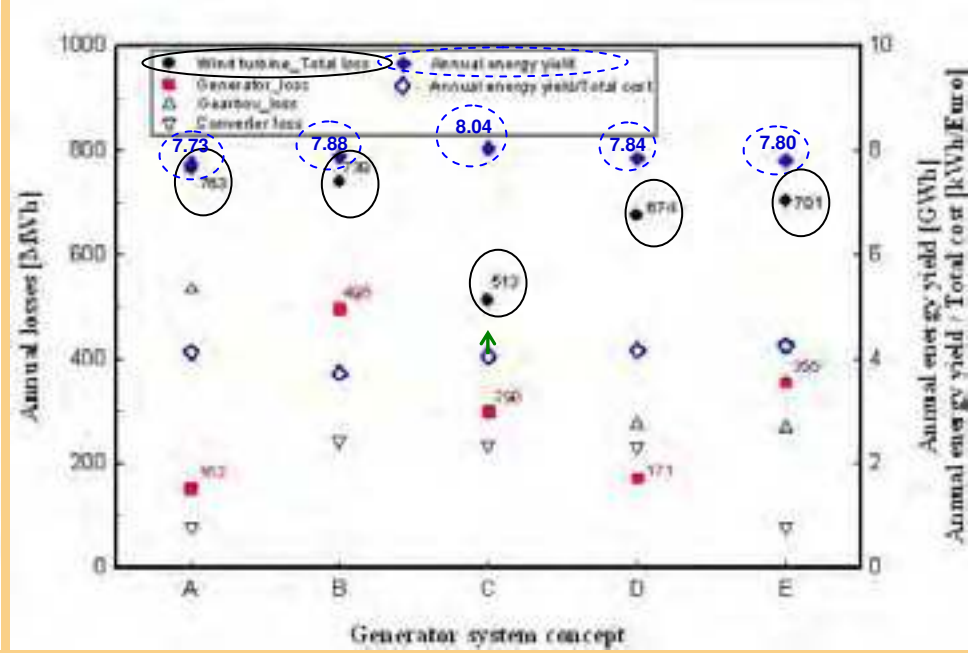
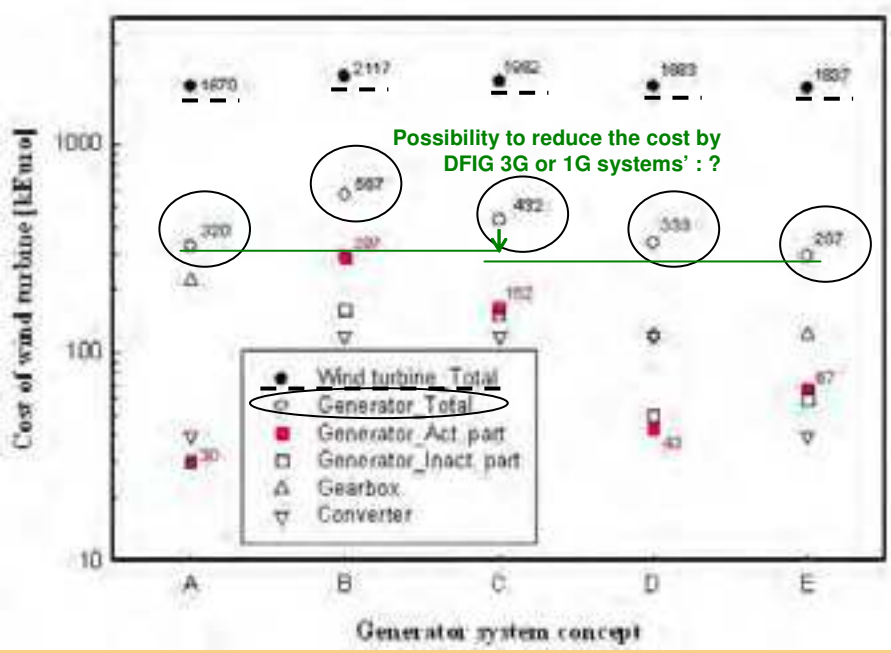

# Task 1B.2.c\_1: Benchmark and concept reports on devices and converters.

## Analysis of Matrix Converters

- “**all silicon**” AC/AC converter
- **without DC-link**
- formed by  $n \times m$  **bidirectional switches**
- **any** of the **outputs** can be connected to **any input** phase.
- bidirectional topology, it can operate in **four quadrants**

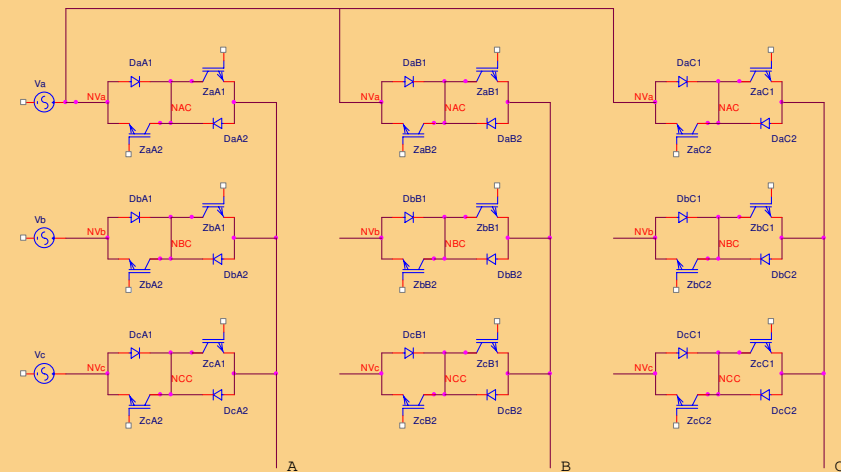

Structure of a three-phase matrix converter

# WP1B4 Up-scaling

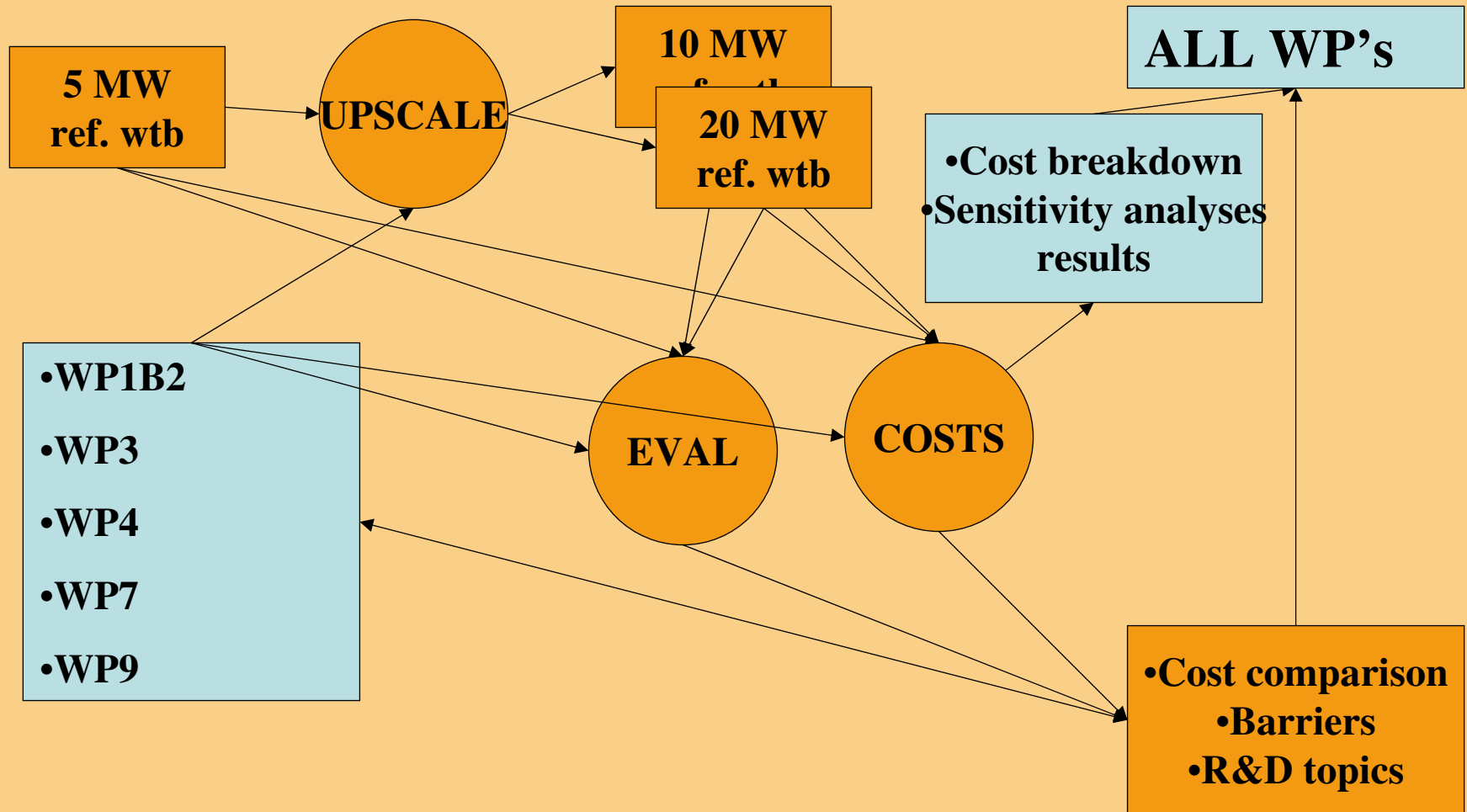

# WP2 Aero-dynamics and Aero-elastics

## OBJECTIVES

1. Development of **nonlinear structural dynamic** models (modeling on the micromechanical scale is input from WP3).
2. **Advanced aerodynamic models** covering full 3D CFD rotor models, free wake models and improved BEM type models. (The wake description is a prerequisite for the wake modeling in WP8).
3. Models for **aerodynamic control features and devices**. (This represents the theoretical background for the smart rotor blades development in WP 1.B.3)
4. Models for analysis of **aeroelastic stability** and total **damping** including **hydroelastic interaction**
5. Development of models for computation of **aerodynamic noise**.



# Deliverables to other work packages (60 months)

## **Upscaling:**

- Aeroelastic modelling of scaled-up WT

## **Smart rotor blades:**

- Modelling of camber line deformation
- Vortex generators

## **Flow:**

- CFD models of terrain
- Wake models

## **Innoblade:**

- CFD computations
- Flutter calculations
- Aeroacoustics

## **Foundations:**

- Hydroelastic models



# WP 4 Offshore support structures: fixed & floating

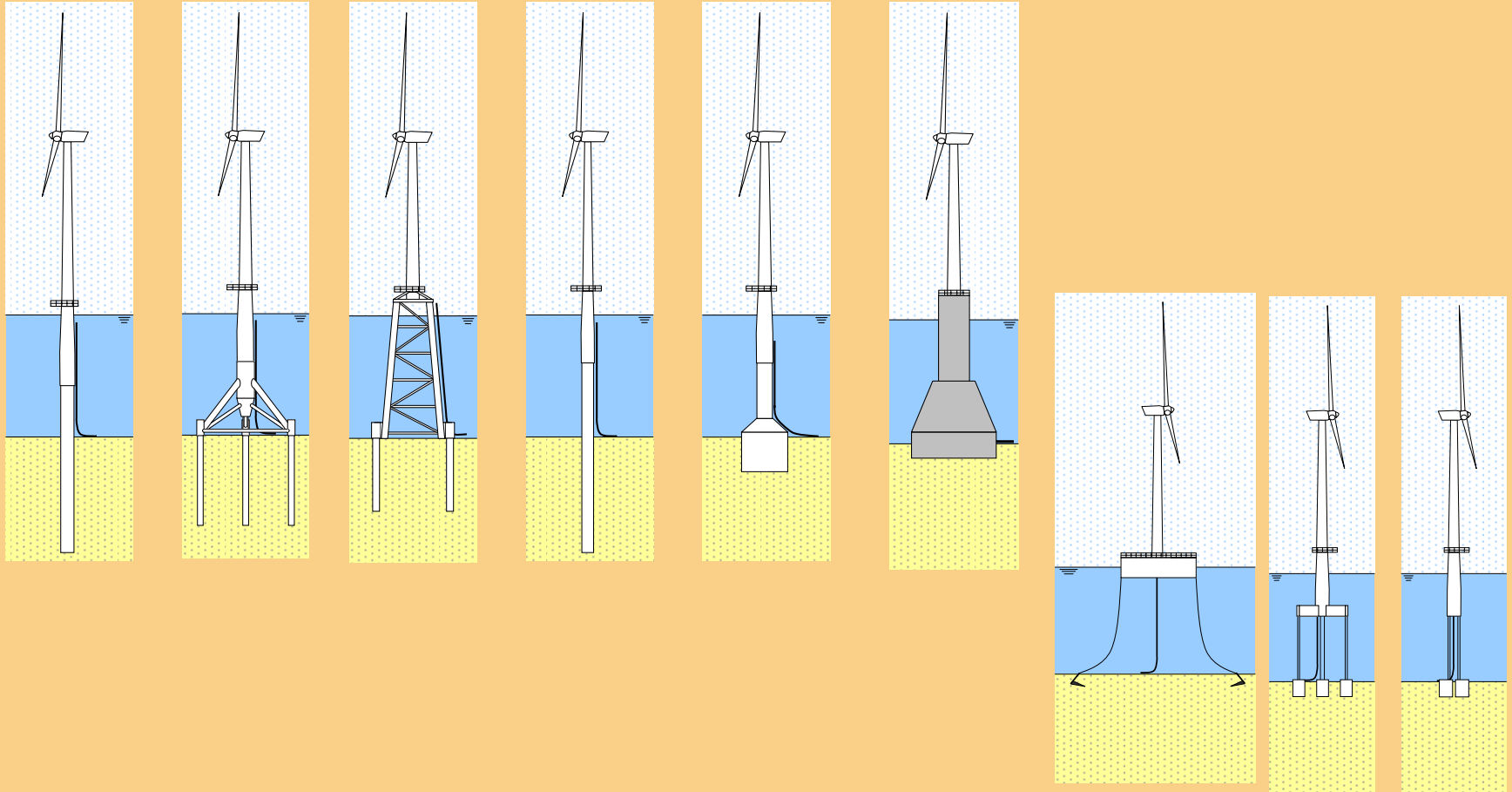



# Support structure evaluation: Average results

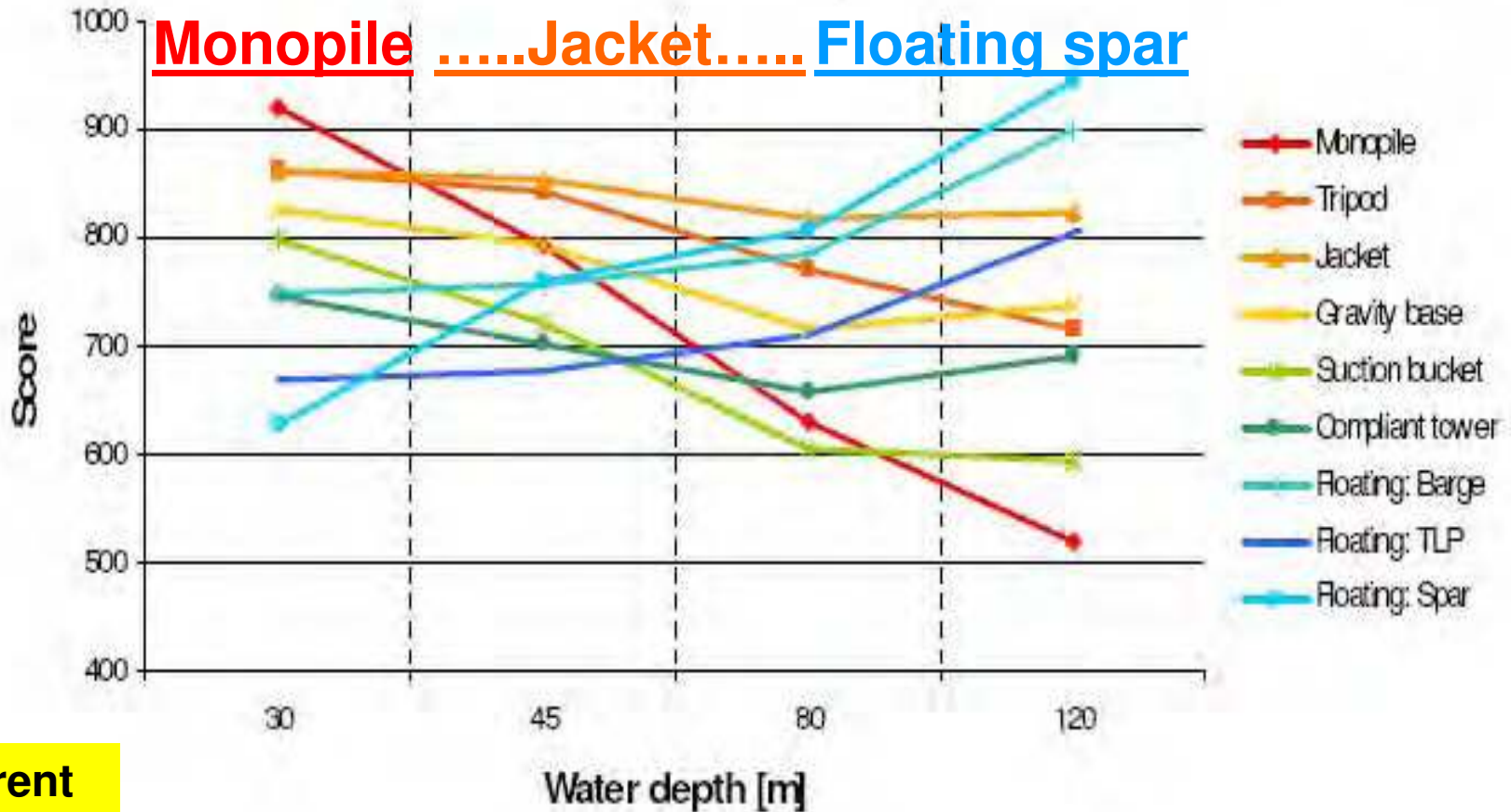

**Current designs (< 20 m):  
Monopile,  
(GBS)**

**Current design:  
1<sup>st</sup> Jacket**



# Results from First Year

## WP 5: Control

- **Controller design and évaluation**
  1. Algorithm development and evaluation
  2. Hardware testing and optimisation
- **Field testing and evaluation**
- **Grid and farm integration**
  1. Wind Farm optimization
  2. Electrical interaction in the network
- **Interaction with other work packages**



# WP6. Remote sensing EWEC Posters

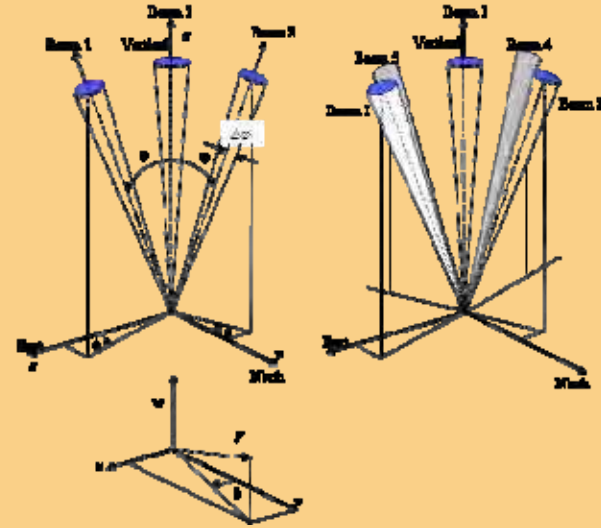
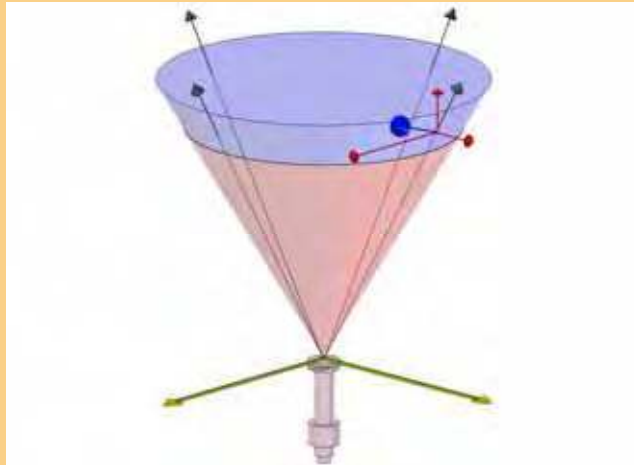

# Lidar and cup at 116m vs time, all data (unfiltered)

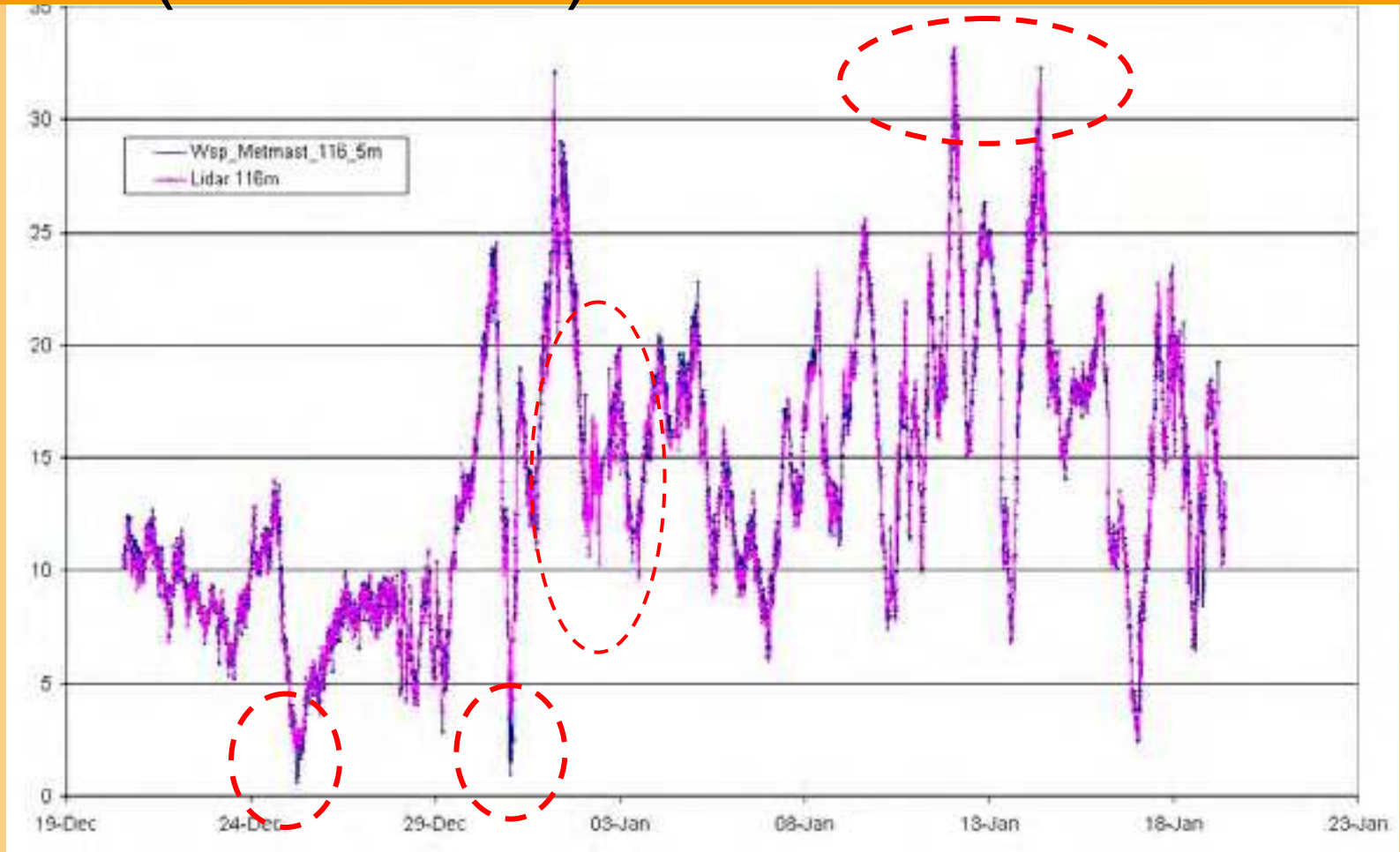

# WP 8 Flow

- Data collection from Wind Farms - Wakes
- Comparison with existing flow models
- Participate in international standardization (IEC)



# WP 9 Grid

- Emphasis on grid reliability and design conditions for WT coming from grid conditions
- Participate in international standardization (IEC)



# Conclusions

- UpWind successfully started up – huge project
- Results from all Work Packages
- Integration activities are very effective
  
- Industry - and the Scientific communities do work very efficiently together
- European Wind Energy Research Community now well organized in UpWind
- EU Technology Platform starting up



# Questions?



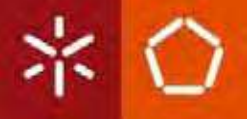

# Wind Power Costs in Portugal

**Carla Saleiro  
Madalena Araújo  
Paula Ferreira**



Introduction

Portug. Electr Power System

Costs Analysis

Discussion of the Results

Conclusions

## Introduction

- Under the Kyoto Protocol, Portugal, as an EU member state should limit the increase of their GHG emissions to 27% from 1990 levels by 2008 - 2012;
- In 1990 the energy sector contributed with 67% of the total GHG emissions and, in this sector, the activities related with the electricity and heat industry with 35%;
- Under the Directive on Renewable, Portugal must achieve a target of 39% of its electricity production from RES in terms of gross electricity consumption in 2010;

Introduction

Portug. Electr Power System

Costs Analysis

Discussion of the Results

Conclusions

## Introduction

- The Portuguese Government reinforced the promotion of hydroelectric resources and the support to the development of renewable energy resources, such as wind, mini-hydro, biomass, photovoltaic and waves;
- Portugal is strongly dependent on external energy sources and the only national resources come from the renewable sources, specially the hydro sector;
- The large hydro is the most important source for electricity production, but it is dependent on the climatic conditions and has been facing serious environmental obstacles;
- With the marginal contributions of the remaining energy sources it is expected that the wind power sector will be very important for the objectives fulfilment.

## Portuguese Electricity System

Introduction

Portug. Electr Power System

Costs Analysis

Discussion of the Results

Conclusions

### Public Electricity System (PES)

### Independent Electricity System (IES)

- Non-binding Electricity System (NES)
- Special Regime Producers (SRP) – cogeneration and renewable plants

Year	2005
------	------

Hydro Production	PES Central	4339
	NES Central	243
	<b>Total</b>	<b>4582</b>

Thermal Production	Coal	1776
	Fuel+Diesel	1673
	Fuel/Gas	236
	Natural Gas	2166
<b>Total</b>	<b>5851</b>	

Special Regime Production	Thermal	1159
	Hydro	333
	Wind	896
	<b>Total</b>	<b>2388</b>

Installed Power (PES/NES)	10433
Total Installed Power	12821

**Figure 1.** Installed power, in Portugal (Source: REN).

→ SPR reached 18,5% of the total installed power and represent almost 14% of the total electricity production.

## Renewable Energy Source

Introduction

Portug. Electr Power System

Costs Analysis

Discussion of the Results

Conclusions

**Table 1.** National targets for the electricity production from RES.

<i>Renewable Source</i>	<i>2004 (MW)</i>	<i>2010 (MW)</i>
Wind	616	4 700
Small hydro ( $\leq 10$ MW)	265	400
Large hydro ( $\geq 10$ MW)	4 294	5 000
Biomass	456	330
Photovoltaic	2	150
Tide		50
<b>Total</b>	<b>5633</b>	<b>10 630</b>

In 2010, hydro will maintain a dominant position, but its share will be reduced largely due to the increase of the wind sector.

## Wind Power Sector

Introduction

Portug. Electr Power System

Costs Analysis

Discussion of the Results

Conclusions

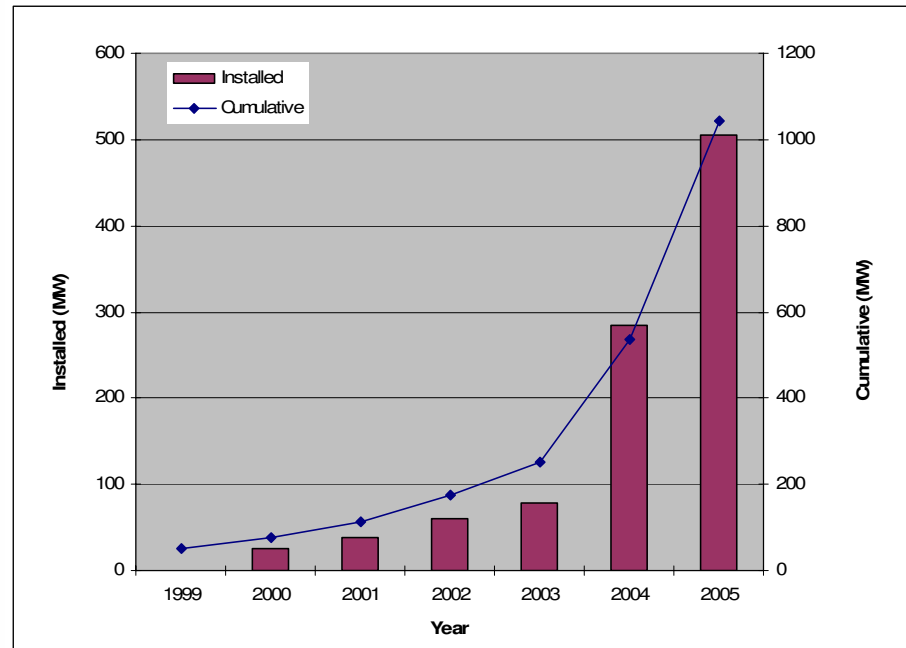

**Figure 2.** Installed and cumulative wind power, in Portugal (Source: DGGE, 2006).

The average annual rate (1999 – 2005) was 67%.

This source of energy represented:

- 20% of the renewable electricity production
- 3,3% of the total electricity production

Portugal is still distant of the European leaders, namely from:

- Germany – 18 GW
- Spain – 10 GW
- Denmark – 3 GW

Introduction

Portug. Electr Power System

Costs Analysis

Discussion of the Results

Conclusions

## Wind Power Sector

To reach the national objectives it is necessary:

- to install an average of 732 MW/year
- to grow to an annual average rate  $\approx 36\%$



Although the great potential, some barriers exist:

- delays in the licensing processes;
- difficulties on the access to the grid.

Introduction

Portug. Electr Power System

Costs Analysis

Discussion of the Results

Conclusions

## Method

The equation used to calculate the *Levelized Electricity Generation Cost (EGC)* is:

$$EGC = \frac{\sum [ (I_t + M_t + F_t + X_t) (1+r)^{-t} ]}{\sum [ E_t (1+r)^{-t} ]}$$

were:

EGC – Average lifetime levelized electricity generation cost

$I_t$  – Investment expenditure in the year t

$M_t$  – Operations and maintenance expenditure in the year t

$F_t$  – Fuel expenditure in the year t

$X_t$  – External expenditure in the year t

$E_t$  – Electricity generation in the year t

r – Discount rate

## Data Sources

Introduction

Portug. Electr Power System

Costs Analysis

Discussion of the Results

Conclusions

**Table 2.** Data and system characteristics of wind farm and CCGT.

	Wind	CCGT
Installed capacity	20 MW	1200 MW
Load factor	22%	85%
Thermal efficiency	-	57%
Life time	20 years	25 years
Investment costs	1206.20 €/kW	514.19 €/kW
O&M annual costs	15.37 €/kW	23.59 €/kW
Fuel costs	-	22.23 €/MWh

**Table 3.** External costs for different damage estimates (ExternE).

External costs	Wind (€/MWh)	CCGT (€/MWh)
Low	0.02 – 0.07	1.93
Mid 3%	0.11 – 0.31	9.41
Mid 1%	0.29 – 0.81	24.02
High	0.87 – 2.44	72.54

- constant pricing was used.
- based on the 2005 value.
- discount rate of 5 and 10%.

Not included:

- backup capacity to compensate wind intermittency and fluctuations;
- reinforce the distribution and transmission systems;
- feed-in tariffs.



## Results

Costs	Wind		CCGT	
	(€/kW)	(€/MWh)	(€/kW)	(€/MWh)
<b>1. Investment</b>				
r = 5%		50.23		4.90
r = 10%	1206.20	73.52	514.19	7.61
<b>2. O&amp;M</b>				
r = 5%		7.98		3.17
r = 10%	15.37	7.98	23.59	3.17
<b>3. Fuel</b>				
r = 5%		--		38.98
r = 10%	--	--	22.23 €/MWh	38.98
<b>4. External</b>				
low		0.02 – 0.07		1.93
mid 3%		0.11 – 0.31		9.41
mid 1%		0.29 – 0.81		24.02
high		0.87 – 2.44		72.54
<b>Total cost (no external)</b>				
r = 5%		<b>58.21</b>		<b>47.05</b>
r = 10%		<b>81.50</b>		<b>49.76</b>
<b>Total cost (with external)</b>				
r = 5%				
low		58.23 – 58.28		48.98
mid 3%		58.32 – 58.52		56.46
mid 1%		58.50 – 59.02		71.07
high		59.08 – 60.65		119.59
r = 10%				
low		81.52 – 81.57		51.69
mid 3%		81.61 – 81.81		59.17
mid 1%		81.79 – 82.31		73.78
high		82.37 – 83.94		122.30

**Table 4.** Annual levelized costs for the two technologies.



### Analysis and Discussion of the Results

- Introduction
- Portug. Electr Power System
- Costs Analysis
- Discussion of the Results
- Conclusions

Not including external costs it can be verified that:

- Investment and O&M costs of wind power plants are considerably higher than the gas technology;
- Load factor of renewable energy is low when compared with the CCGT system;



CCGT is more attractive than the wind technology

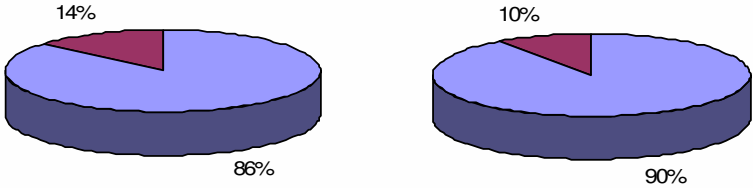

Figure 3. Estimated cost structure for wind plant (5% and 10% discount rate).

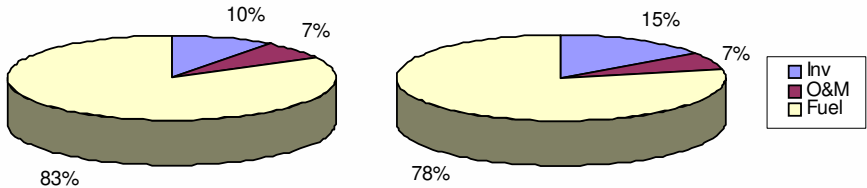

Figure 4. Estimated cost structure for CCGT (5% and 10% discount rate).



### Analysis and Discussion of the Results

- Introduction
- Portug. Electr Power System
- Costs Analysis
- Discussion of the Results
- Conclusions

Including external costs it can be verified that:

- In wind technology the investment costs still represent a high proportion (% total cost);
- In gas technology the fuel costs have a significant weight for low estimates, but in high estimates the external costs are the one that most contribute to the total cost;

CCGT continues to be more attractive than the wind technology, except for high estimates

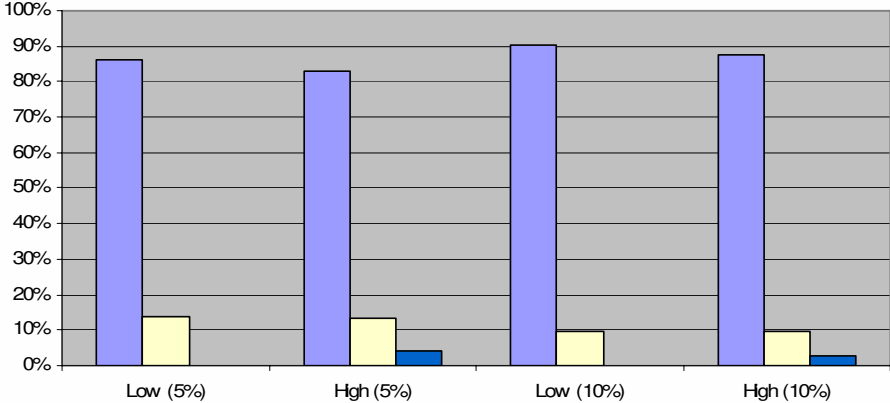

Figure 5. Estimated cost structure for wind plant (5% and 10% discount rate).

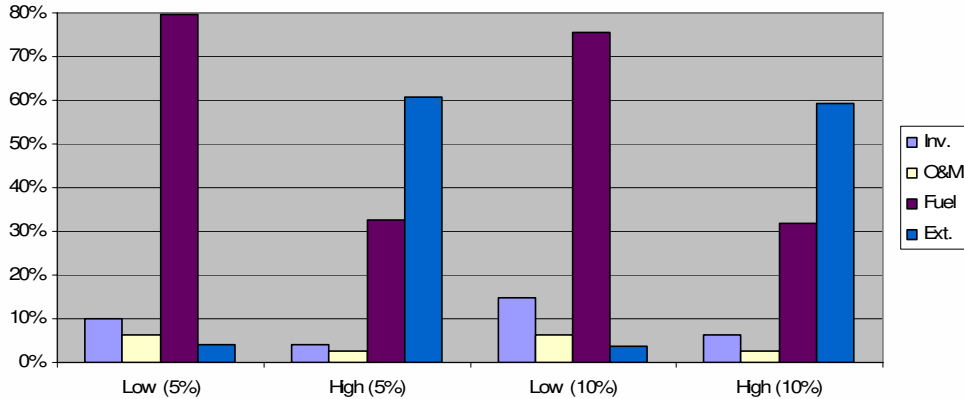

Figure 6. Estimated cost structure for CCGT (5% and 10% discount rate).

Introduction

Portug. Electr Power System

Costs Analysis

Discussion of the Results

Conclusions

## Sensitive Analysis

- Discount rate:

The CCGT technology is less affected by the variation of the discount rate.

- O&M escalation rate:

The increase of the total costs diminishes as the load factor increases (the percentage of the costs of O&M is smaller).

- Fuel escalation rate:

The total costs for the CCGT increase significantly, being more accentuated for lower discount rates and for larger load factors.

- Load factor:

The larger the load factor the lower the production costs.  
The reduction of the costs is less accentuated in the CCGT system than in the wind system.

Introduction

Portug. Electr Power System

Costs Analysis

Discussion of the Results

Conclusions

## Conclusions

- CCGT is still more attractive than the wind energy when only financial aspects are accounted for.
- When external costs are considered, the electricity generation costs for the two technologies are similar.
- However, for high estimates (of GHG emissions) the wind system reaches more attractive values.
- The sensitivity analysis showed that :
  - the increasing of fuel escalation rates is the parameter that originates larger effects in the Levelized Electricity Generation Cost.
  - the Levelized Electricity Generation Cost (without environmental costs) of a wind farm is more positively influenced by the load factor than the CCGT system.

Introduction

Portug. Electr Power System

Costs Analysis

Discussion of the Results

Conclusions

## Conclusions

- The results were obtained assuming 2005 constant values. However, in the near future, it can be expected:
  - an increase on conventional systems costs
  - a decrease on renewable systems costs
  - an increase of the natural gas price (almost 84% between 2003 and 2005)
- The expansion of the wind technology in Portugal will influence significantly the energy system costs, but it is fundamental for the attainment of the European and National Energy and Environment goals.
- The expectations and incentives around the wind energy are comprehensible:
  - it is a renewable energy source
  - the reduction of the investment costs expectedly may turn this technology economically attractive to the investors
  - if the life cycle is analysed, and the external costs included, it can become more advantageous than the conventional systems.
  - the increase of the fossil fuel prices is creating a new competitive advantage for wind power systems.



**THANKS**



# Economic and Financial Feasibility of Wind Energy - Case Study of Philippines

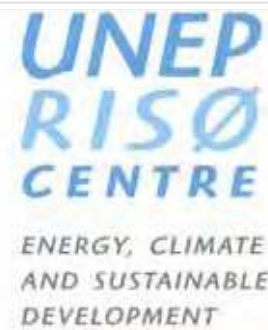

---

**Risø International Energy Conference 2007, 22 - 24 May**

**(Presentation is based on the work carried out under the EU-Asean Facility funded project:  
*Feasibility Assessment and Capacity Building for Wind Energy Development in  
Cambodia, the Philippines and Vietnam*)**

Jyoti Prasad Painuly





# Energy Policy in Philippines

---

- 60% self-sufficiency by 2010 (55.5% 2004)
  
- Increase 100% RE based capacity in 10 years (to reach 9147 MW in 2003)
  
- Wind Energy;
  - 425 MW in 10 years (2005 base year)
  - 16 sites in Wind Investment Kit
  
- Renewable Energy Bill 2006
  - Renewable portfolio standard
  - Green energy option for end users
  - Net metering

- 
- Clean energy funds
  - Fiscal incentives- IT holidays, duty rebates, VAT rebate etc.
  
  - Wind Energy Potential
    - Initial assessment 76000 MW (NREL)
    - Realizable 7400 (WWF)
    - Target for 10 years; 425MW
      - First wind energy investment kit; 345 MW
      - Installed 25MW (Northwind in Luzon)



## Sites in the Philippines



St. Ana

Dinagat Island



# Sta. Ana



Raising-up the tower



The mast is located 10 m asl  
Measurement heights 10 and 27 m

14



# Location and wind data

---

- St. Ana (30 MW)
  - Cagayan region (Luzon Island)
  - Zone 1 (wind upto 70 m/sec)
- Wind Data
  - Mean wind speed 4.9 m /sec (8 months; Sept 2005-April measurements)
  - Max. 18m /sec
- Est. Generation
  - 80 GWh /yr (57-79, depending on location) using 2 MW V66/67 m wind turbine
  - 60MWh/ yr (43-61) using 2MW V80/67

# Financial Analysis of St. Ana Wind Power Project

Background	
Investment	\$51.8 mill. Includes feasibility study, project and site development work, engineering, plant and equipments, installation, transmission lines (1\$= 52 P)
O & M Costs (increase 3% per year)	\$1.1 mill. per year. includes land lease, property tax, labour, other operational expenses etc.
Annual Energy Production	<b>80 GWh</b> (net) -7% losses (Transmission) -- From year 1, above AEP
Plant life	20 years- 10% Salvage Value

<p>Income tax</p>	<ul style="list-style-type: none"> <li>- No tax for 6 years</li> <li>- 30% after that</li> </ul>
<p>Projected power sale rate</p>	<p>P 4.91 / kWh          (and escalation 3% per year)</p>
<p>CDM</p> <ul style="list-style-type: none"> <li>- CER prices</li> <li>- Emission red. coeff. (eq. CO<sub>2</sub>)</li> </ul>	<p>\$6/ ton and \$10/ton          0.625 t/ MWh</p>
<p>Note: CDM revenues assumed for entire plant life</p>	

# Financial Structuring

---

- Ownership Structures
  - Private
  - Utility
  - Public (Central or Provincial)

Each has its own costs and financial arrangement possibilities.

Base Case:

Equity 20%

Loan 80%; 8%, 15 Yrs+ 6 Yr (Grace Period)



# NPV and IRR Calculations

---

- Discount rate
  - Hurdle rate was calculated based on cost of financing
  - 8.68% (base case)

# Hurdle rate

- ❑ Required IRR  $\geq$  hurdle rate
- ❑ The hurdle rate is weighted average cost of the capital (wacc)+ spread
- ❑ WACC is calculated using the following formula;
- ❑  $WC = (E/TC) * RE + (D/TC) * RD * (1-T)$

Where;

WC is weighted average cost of capital

E is the equity contribution

D is the debt

TC is the total cost (D+ E)

RE is the required return on equity (11%)

RD is required rate of return on debt (rate of interest + FE risk (1.5%) and guarantee (2%) for foreign loans), and

T is the tax rate (30%)

Discount rate= Hurdle rate+ spread (2%)

<p>80GWh site location</p> <p>NPV</p> <p>Base Case: Discount rate 8.68%  (Domestic loan at 8% with 15  year term+ 6 yr GP)</p> <p>Discount rate <b>13.2%</b>  (Risk adjusted)</p> <p>Which one to choose?</p>	<p>P 243 Mill.</p> <p>(P 553 mill)</p>
<p>IRR</p>	<p><b>9.83%</b></p> <p>(Northwind 9.3%, tariff P 4.43/kWh;  1 USD= 57P)</p>
<p>MIRR</p>	<p>7.56</p>

# Check

## □ Impact of CDM

CER Prices	\$6/ton	\$10/ton
IRR	10.46	10.87
MIRR	7.78	7.93

Is it acceptable now?

- 
- What is my acceptable IRR ? 17-18% private investors?
  - This is economic IRR, and if tariff and investment and other data is without distortion, it gives a basis for decision making at policy level (although it is not strictly an economic analysis).
  - For an investor, decision criteria will typically be Financial IRR, which depends on financing arrangements.
  - Analysis- nominal v/s real

**Table1; Base Case and variations**

(NPV in million P)

<b>Indicator</b>	<b>Base case</b>	<b>Elect Tariff +10%</b>	<b>Invest ment +20%</b>	<b>El. Gen. - 20%</b>	<b>O&amp;M costs +20%</b>
NPV 8.68% (hurdle rate)	243	614	-230	-385	138
With CDM; \$6/t	379	750	-95	-276	273
With CDM \$10/t	469	840	-5	-204	364
NPV 13.2%	-553	-278	-1052	-1020	-632
With CDM; \$6/t	-453	-178	-951	-939	-531
With CDM; \$10/t	-386	-110	-884	-885	-464
IRR	9.83%	11.53%	7.75%	6.79%	9.33%
With CDM; \$6/t	10.46%	12.14%	8.30%	7.33%	9.97%
With CDM; \$10/t	10.87%	12.54%	8.66%	7.69%	10.39%
MIRR	7.56%	8.16%	6.75%	6.35%	7.37%
With CDM; \$6/t	7.78%	8.36%	6.97%	6,58%	7.61%
With CDM; \$10/t	7,93%	8.50%	7,11%	6,72%	7.76%
IRR-Investor	14.03%	21.08%	7.28%	4.71%	12.26%
With CDM; \$6/t	16.47%	23.93%	8.89%	6.13%	14.57%
With CDM; \$10/t	18.19%	25.89%	10.02%	7.11%	16.20%

# Financing Scenarios

---

S.No.	Financing scheme	Discount rate
B	Base case; Domestic loan at an interest rate of 8%, 15year term with a grace period of 6 years	8.68
F1	Loan, financed through ODA at 0.3% for 20 years, with a grace period of 10 years.	6.33
F2	JBIC ODA at 0.90% for 20 years and a grace period of 6 years (untied, as applicable to Philippines; <a href="http://www.jbic.go.jp/english/oec/standard/">http://www.jbic.go.jp/english/oec/standard/</a> )	6.66
F3	OECD commercial loan at 5% for 10 years, with a grace period of 1 year (construction period).	8.96
F4	Danida financing; 35% grant and balance 65% as loan at 7%, 10 year term	9.80

**Table 3; Financing Scenarios (NPV in million P)**

Indicator	Base case DBP 8%;15 yr, GP 6 yr	F1 ODA 0.3%;20yr, GP 10 yrs	F2 JBIC 0.90%;20 yr, GP 6 yrs	F3 OECD 5%;10 yr, GP 1 yr	F4 Danida 7%;10 yr (grant 35%), No GP
NPV 13.2%	-553	-616	-610	-609	66
With CDM; \$6/t	-453	-516	-510	-508	167
With CDM;\$10/t	-386	-448	-443	-441	234
Hurdle rate	8.68%	6.33%	6.66%	8.96%	9.80%
NPV	243	753	667	103	567
With CDM; \$6/t	379	915	824	236	692
With CDM;\$10/t	469	1023	930	324	776
IRR	9.83%	9.41%	9.45%	9.46%	13.76%
With CDM; \$6/t	10.46%	10.05%	10.09%	10.10%	14.60%
With CDM;\$10/t	10.87%	10.47%	10.51%	10.52%	15.15%
MIRR	7.56%	7.40%	7.41%	7.41%	8.81%
With CDM; \$6/t	7.78%	7.63%	7.65%	7.65%	9.06%
With CDM;\$10/t	7.93%	7.78%	7.80%	7.80%	9.22%
IRR-Investor	14.03%	50.73%	45.17%	13.32%	21.33%
With CDM; \$6/t	16.47%	53.50%	48.20%	14.71%	23.24%
With CDM;\$10/t	18.19%	55.34%	50.19%	15.67%	24.54%



# Lessons Learnt

---

- Lessons learnt in the case study:
  - St. Ana is not viable as a normal project; load factor at 30% is reasonable.
  - Uncertainties (investment cost, O&M cost, and generation) make it a risky venture even with favourable financing packages.
  - A combination of soft financing and high CDM revenues can make it viable.

---

## □ Conclusions

- Economic viability of wind energy is an issue in Philippines
- Nationally, development of wind can be justified from energy security perspective
- Development of wind energy for global environmental reasons may require carbon financing, supplemented through grants / soft financing, wherever necessary.

---

More info; [www.aseanwind.eu](http://www.aseanwind.eu)

THANK YOU

Contact;  
J.P. Painuly  
UNEP Risoe Centre  
[j.p.painuly@risoe.dk](mailto:j.p.painuly@risoe.dk)

# Wave Energy – challenges and possibilities



By: Per Resen Steenstrup  
[www.WaveStarEnergy.com](http://www.WaveStarEnergy.com)

# Wave energy is an old story....



The first wave energy patent is 200 years old.

Over the last 100 years more than 200 new wave energy devices have been developed and more than 1.000 patents have been issued.

Over the last 30 years more than 400 million EUR have been spent on demonstrators in the sea, with little or no success.

Only in the last 5 years the practical solutions have started to show, with real chances of commercialisation.

## ***Main features for success:***

- Simple storm protection concept.
- Proven technology in the sea.
- Simple and reliable concept, with simple power take off system.
- Scalable to big MW systems in the future.
- Low weight per MW - potential for future cost reductions.



Wave energy concepts World wide, which have been tested in the sea

**Oscillating water column** – floating or fixed coastal installation. Air based Wells turbines as power take off.

**Over topping waves** into a reservoir, with low head turbines as power take off.

**Articulating tubes** with hydraulic power take off.

**Point absorber**, with either water pumps, linear generators or hydraulic power take off systems.

**Multi point absorbers**, with hydraulic power take off.

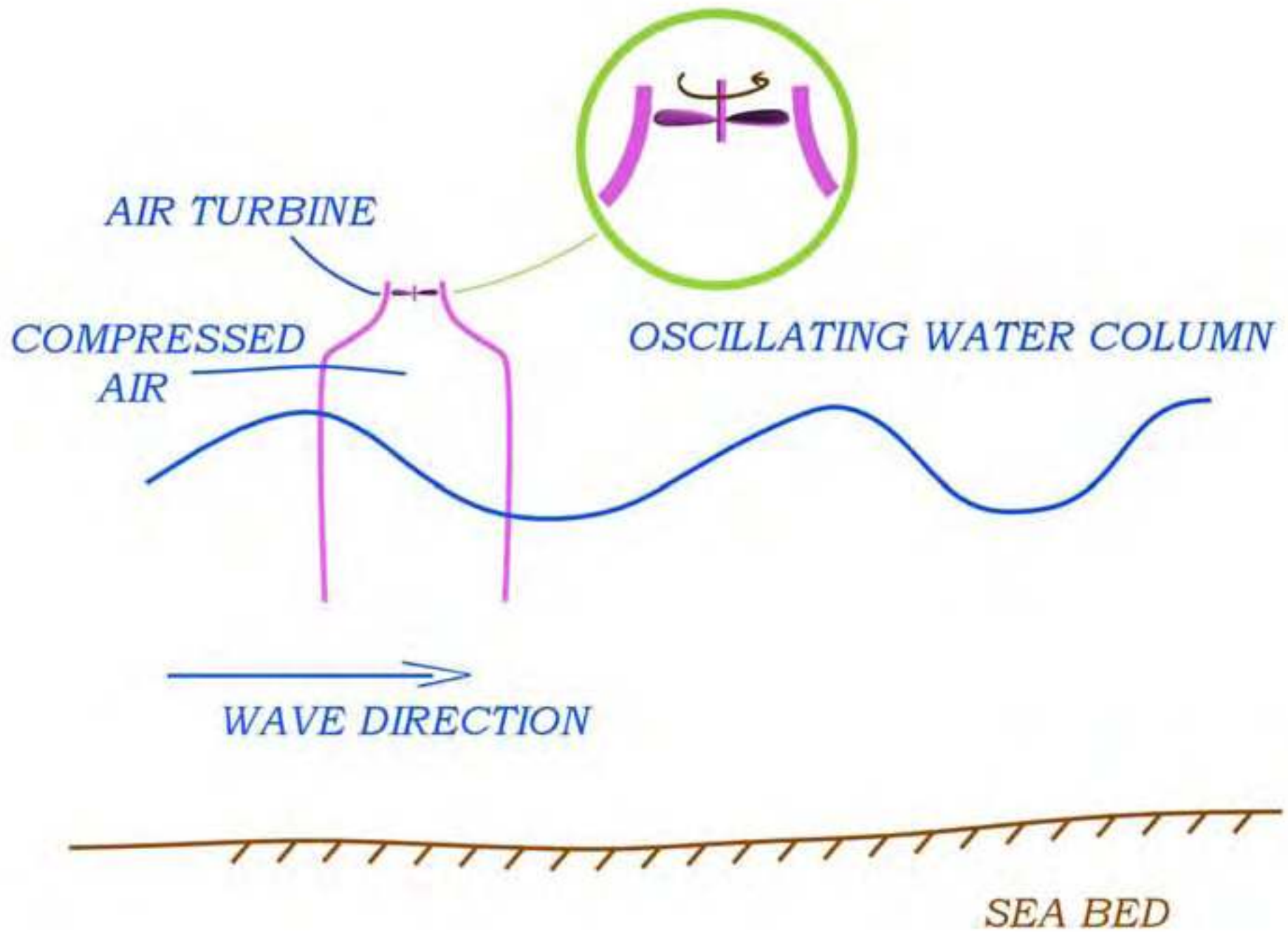

*OVER TOPPING RESERVOIR*

*LOW HEAD  
TURBINE*

*MOORING*

*SEA BED*

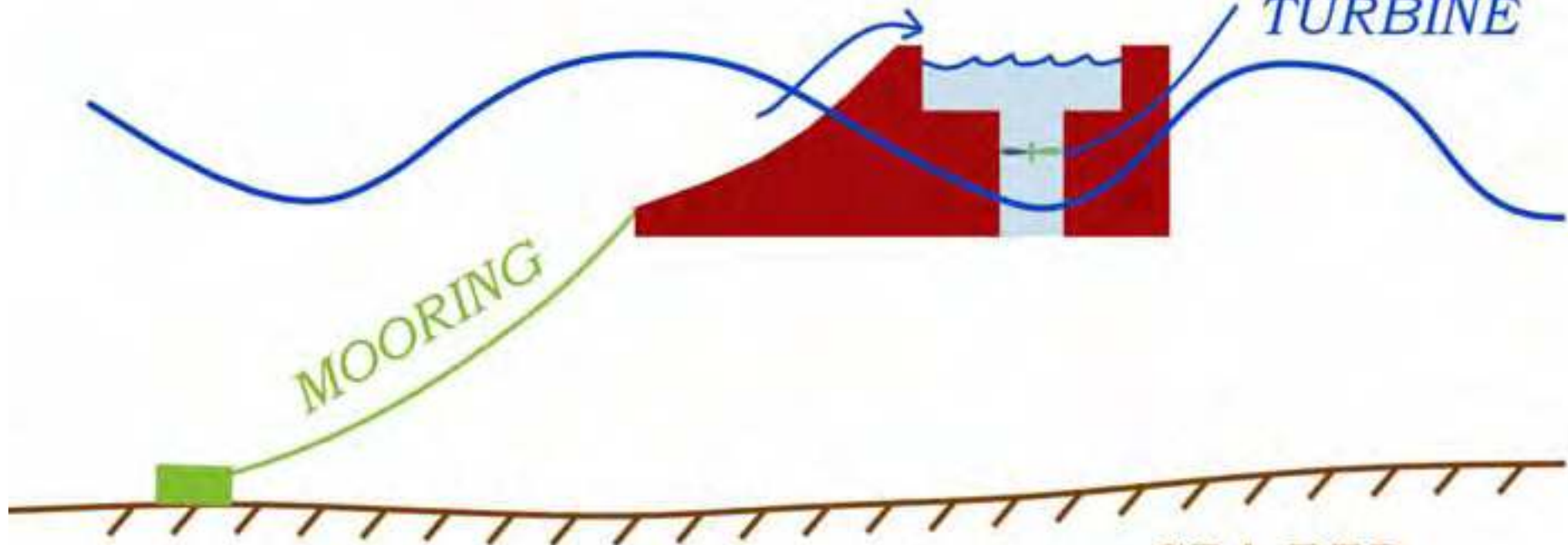



## ARTICULATING TUBES WITH HYDRAULIC JOINTS

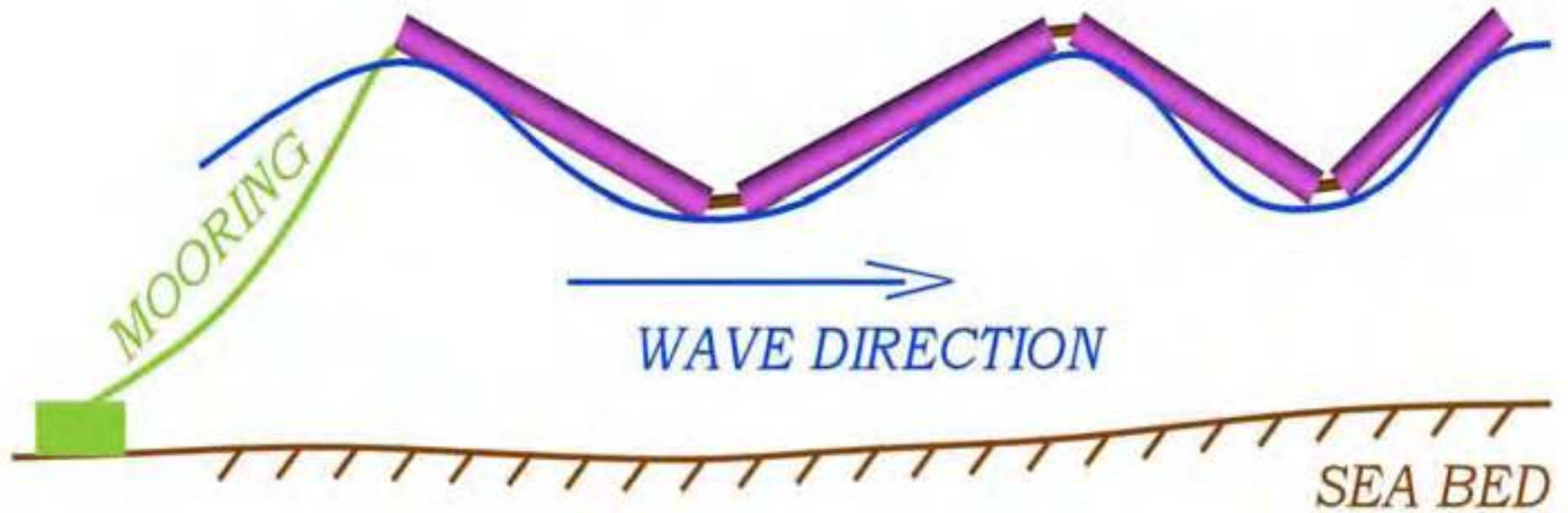

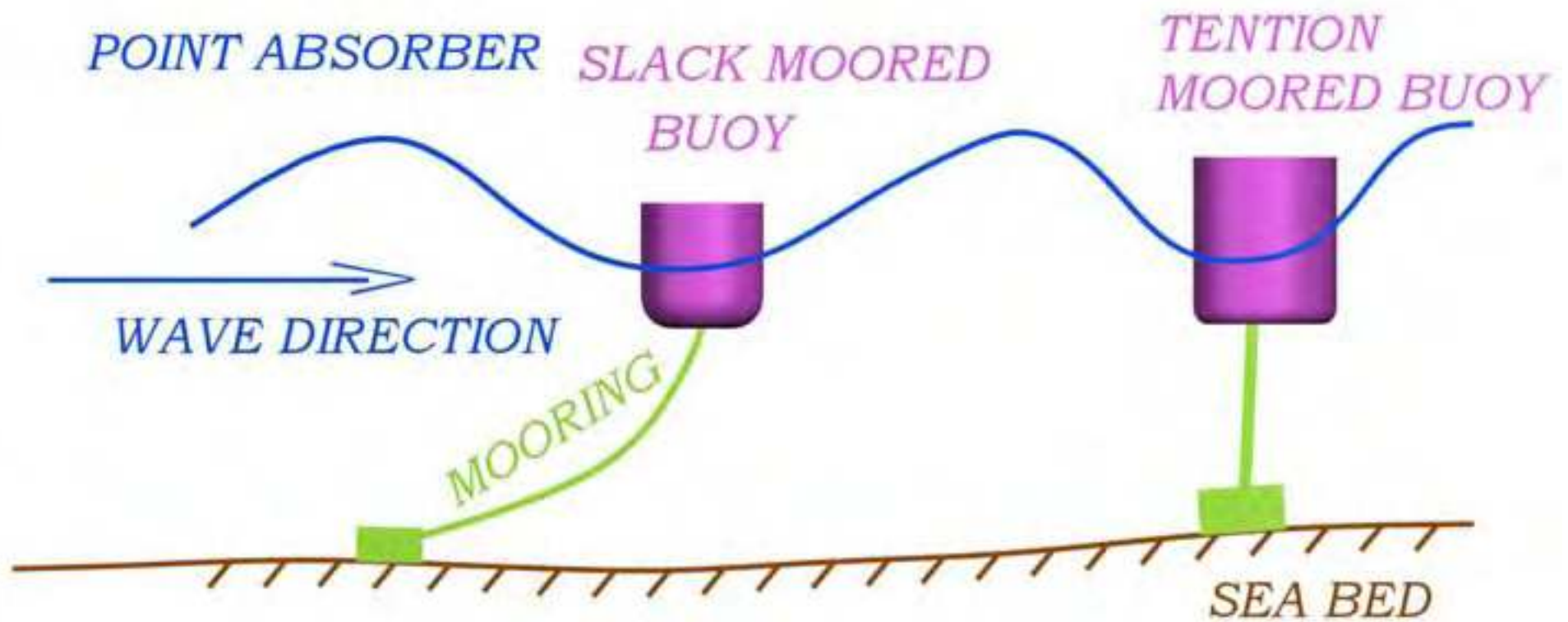

# MULTI POINT ABSORBER

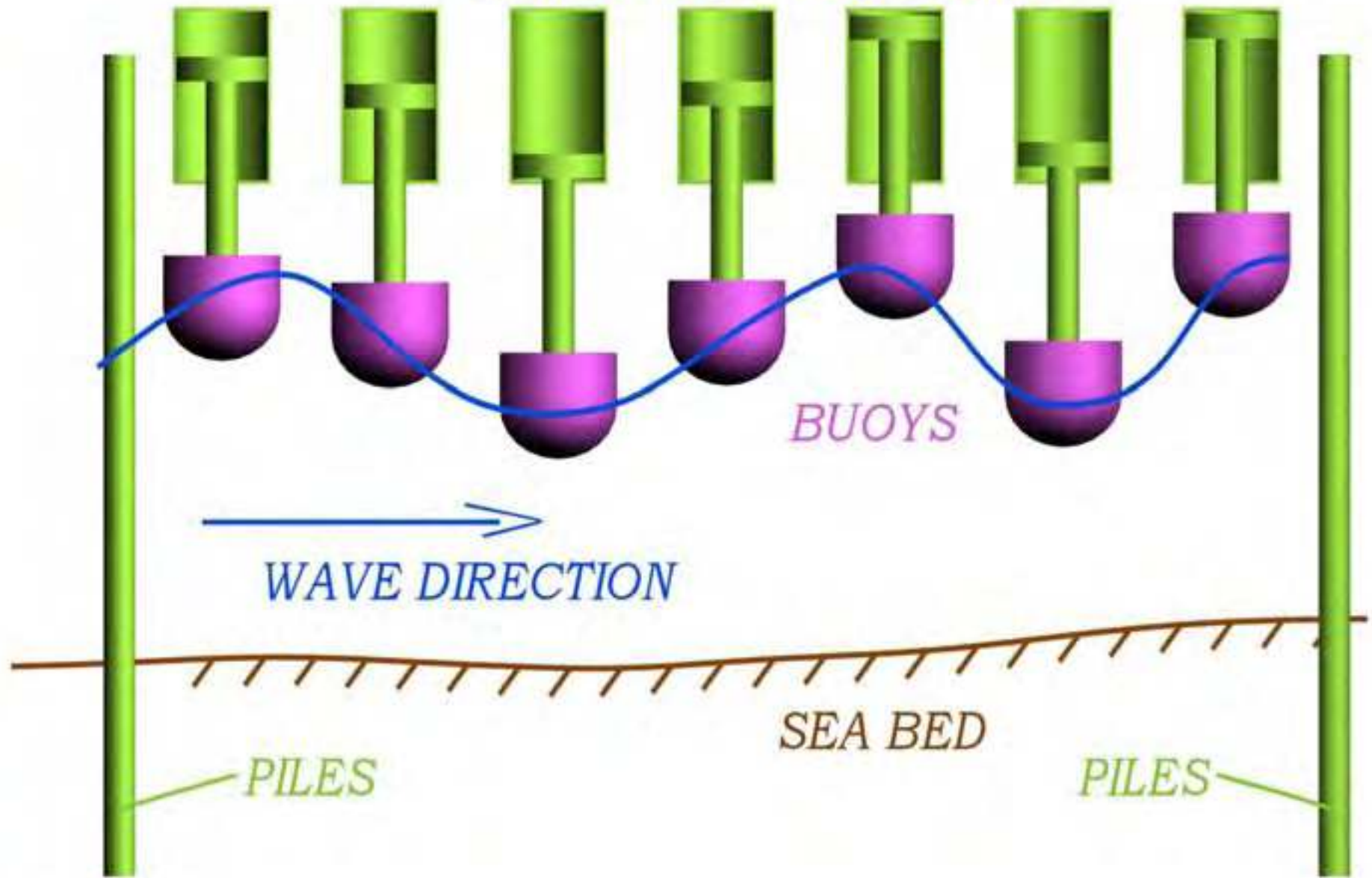

# Wave Star's back ground in head lines.



Wave Star Energy was established October 1st 2003, with the sole purpose of commercialising wave energy.

Over a period of 10 months in 2004 a scale 1:40 converter was extensively tested in regular as well as irregular waves, to document the configuration, optimize the power output and document dynamic behavior compared to a hydro dynamic model.

Based on the extensive tank testing a scale 1:10 converter was designed and built during 2005 and deployed in the sea on April 6th 2006 at Nissum Bredning (DK). The converter was built and instrumented to the same high standard as a full scale converter.

After initial testing of all sub systems the converter was grid connected and put into unattended operation on July 24st 2006.

It has been in operation since then and logged more than 6.000 hours.

# What is special about the Wave Star concept?



It is a simple reliable design, which can be storm protected.  
It sits on piles, just like an offshore structure.

All moving parts are above water and are well protected from the sea environment.

It is only based on standard components and standard offshore - and wind turbine technology.

It is scalable into multi MW converters.

Price and electric production per MW makes it realistic to become commercial over time, and supplement wind turbines on a big scale.



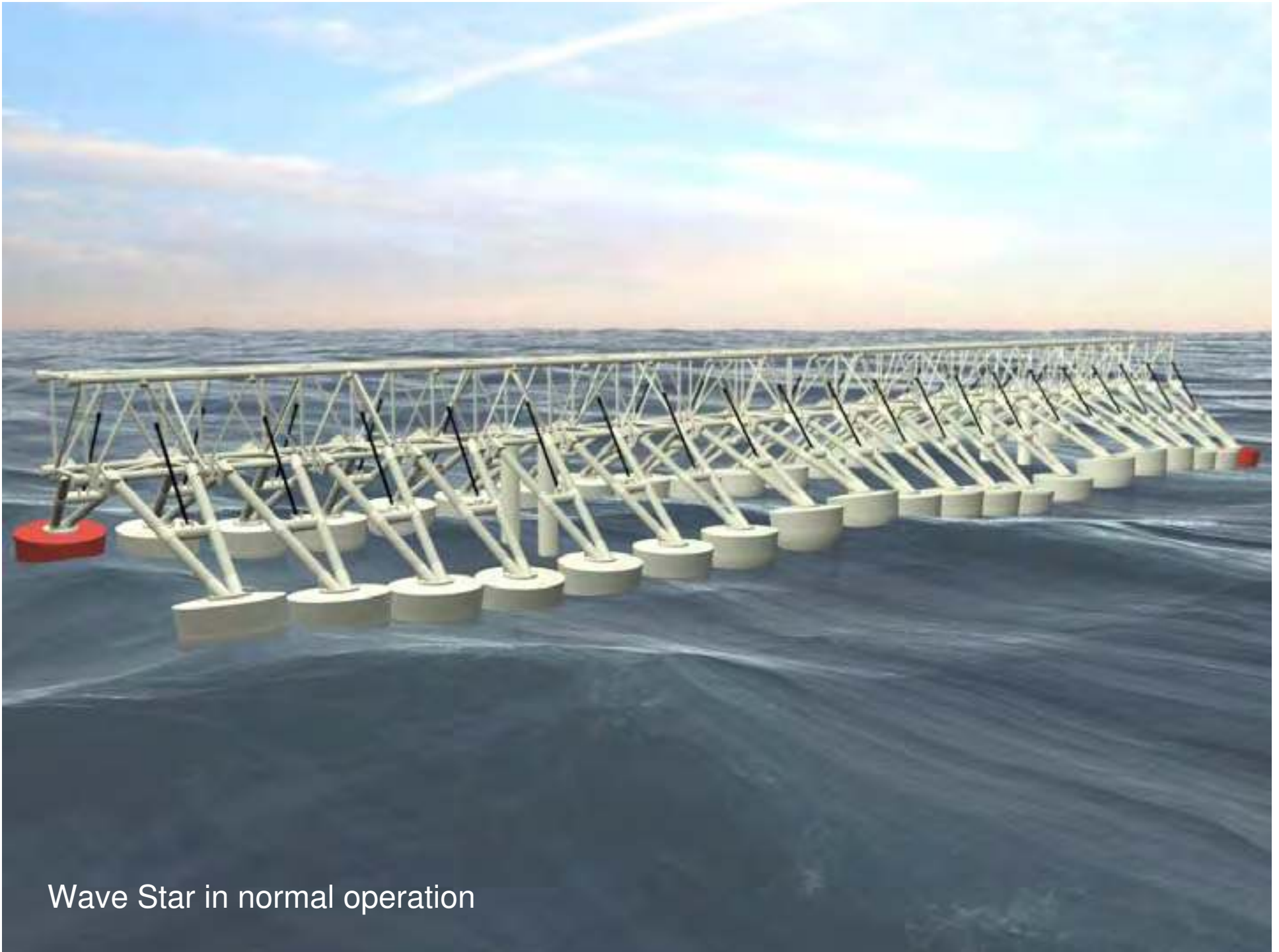

Wave Star in normal operation



Wave Star in storm protection mode

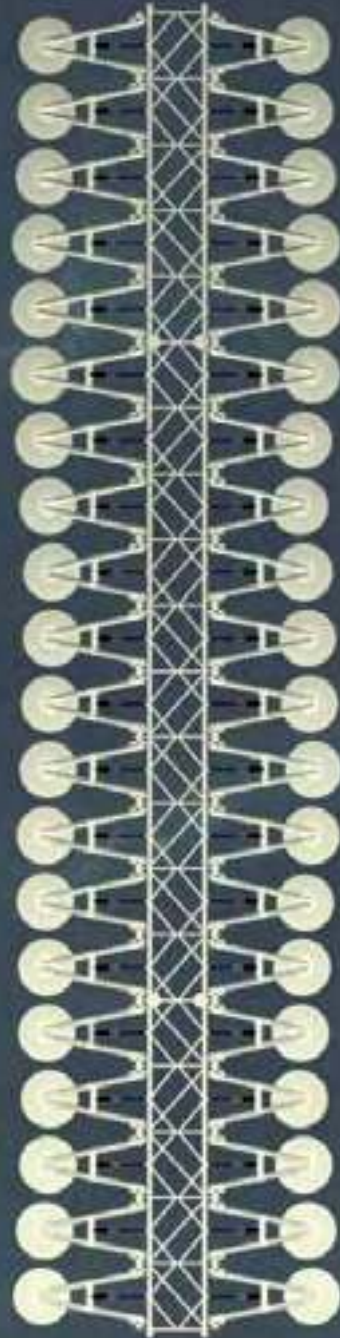

*Dominant  
Wave Direction*

Birds view









Normal operation



Storm protection mode



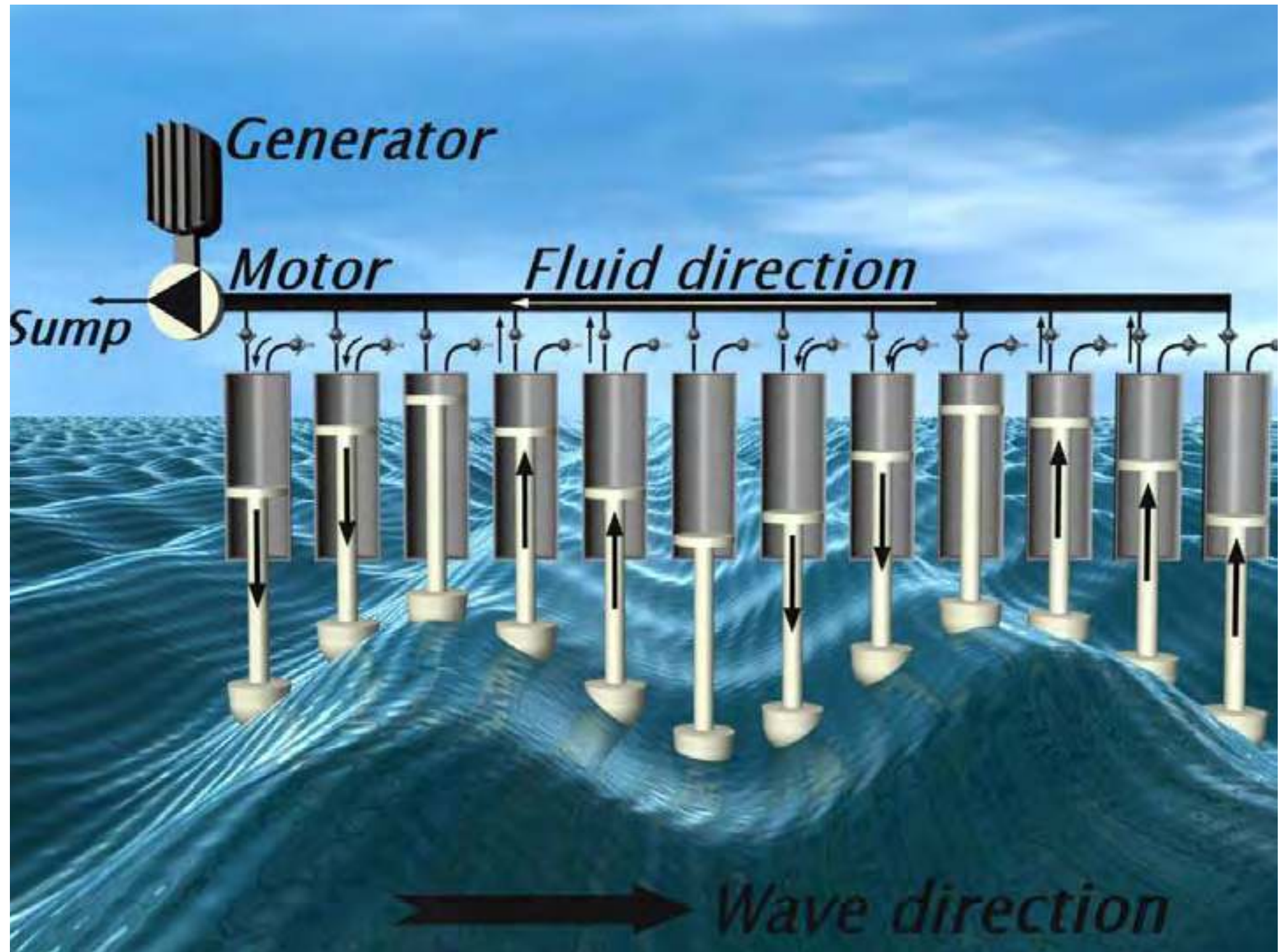



## How does the power scale with size?

The test converter in Nissum Bredning is a scale 1:10 converter. It is 24 m long with 40 floats of each  $\varnothing$  1 m, and operates in 2 m of water. In **0,5 m Hs** the power output is **1.800 W** electric power.

The scale 1:2 converter is 120 m long with 40 floats of  $\varnothing$  5 m and operates in 10 m of water depth. In **2,5 m Hs** the power output is **500 kW**.

The scale 1:1 converter is 240 m long with 40 floats of each  $\varnothing$  10 m and operates in 20 m of water. In **5,0 m Hs** the power output is **6 MW**.

The scale 1,5 :1 converter is 360 m long with 40 floats of each  $\varnothing$  15 m and operates in 30 m of water. In **7,5 m Hs** the power output is **24 MW**.



## What are the plans for the future?

The scale 1:10 converter in Nissum Bredning will continue to operate until August 2008. The goal is to optimize the energy production and obtain long term working experience.

Design and build a scale 1:2, 500 kW converter for Horns Rev in the North Sea during 2007 / 2008 .

Arms and floats for the 500 kW converter will be installed and tested at a pier in the North Sea in 2008.

The scale 1:2, 500 kW will be pre installed at the North of Lolland at Onsevig i 2008 / 2009.

Later transferred and installed at Horns Rev (North Sea) in 2009.



Section of 500 kW machine will be installed here



Roshage Pier

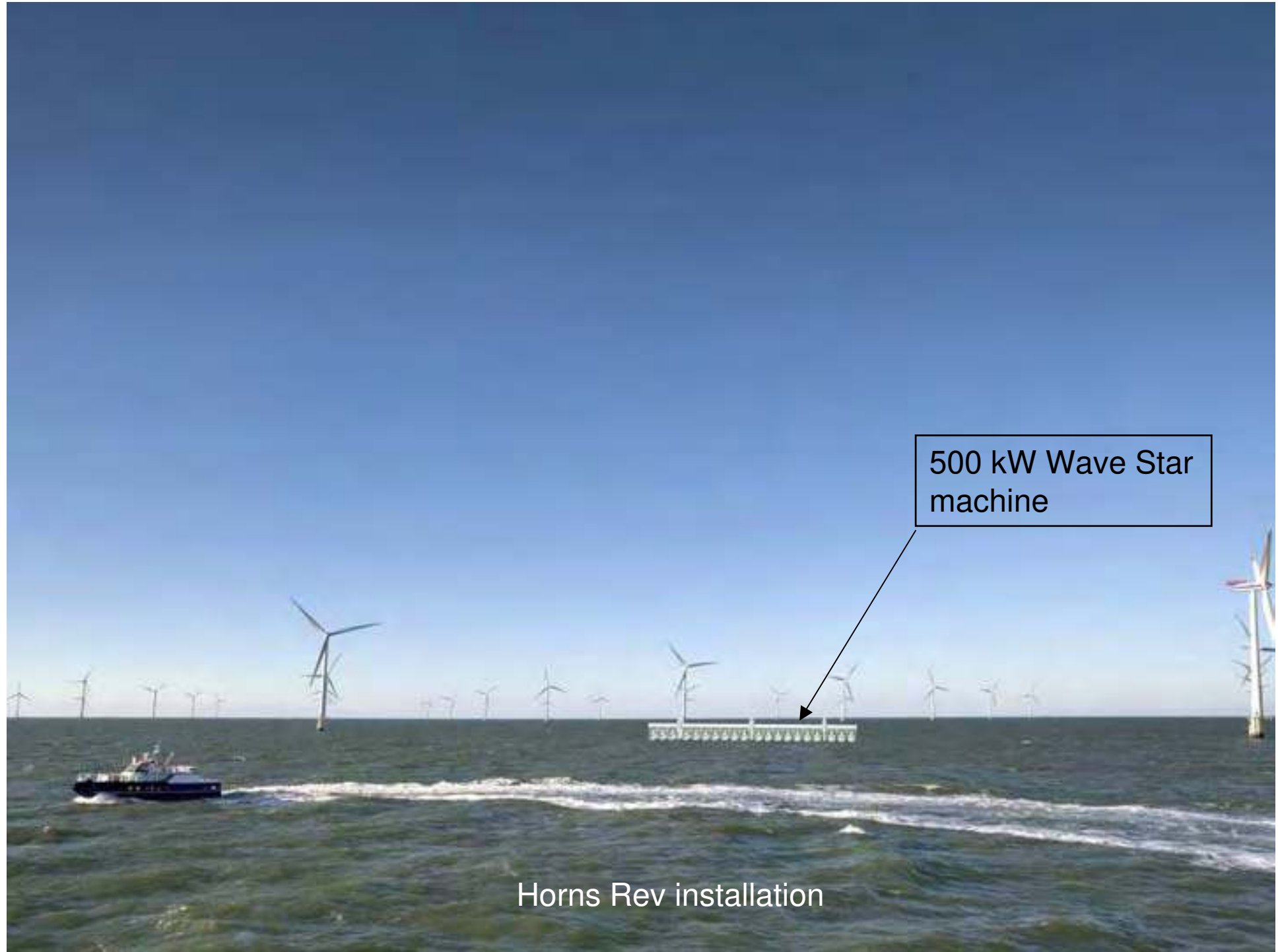

500 kW Wave Star machine

Horns Rev installation



# What are the major challenges for Wave Star in reaching a commercial breakthrough?



Install and operate the first commercial 500 kW Wave Star Energy machine at Horns Rev i 2009 /2010, without any major technical problems or short commings.

Through cost engineering, in the early development phase of the 500 kW machine, bring the kWh cost down to less than 20 EUR cent, even when the machine is operated in 10 m of water depth and in a low wave climate of only 4 kW / m, in average.

Improve realiability of the first 500 kW machine, to make it the most reliable machine in the market.

Scale the machines in small steps to minimize risk.

500 kW, 1,5 MW, 3,0 MW, 6MW, 10 MW, 15 MW , 20MW etc.



Nissum Bredning test system





Visit by the Danish Deputy Prime Minister  
on the 13<sup>th</sup> of April 2007

# Operational costs induced by fluctuating wind power production in Germany and Scandinavia

Peter Meibom, Risø, Technical University of Denmark

Christoph Weber, University Duisburg-Essen

Rüdiger Barth & Heike Brand, IER, University of Stuttgart

## Overview presentation

- Purpose of the study
- Methodology
- Results
- Discussion of integration costs
- Outlook

## Purpose of study

- Analyse the impact on operational costs from increased wind power in Germany and the Nordic countries
- Part of the so-called integration costs of wind power:
  - Grid reinforcements
  - Investment in balancing power plants
  - Increase in operational costs due to more variable operation of conventional plants

## Definition of integration costs of wind power

- Difference between
  - Expected reduction in system costs (need clarification)
  - Realised reduction in system costs
- Expected reduction? (often reduction achieved with dispatchable technology):
  - Gas turbine with same energy production as wind production
  - Constant production with same energy production as wind production

## Methodology

- Calculations with the Wilmar Planning tool ([www.wilmar.risoe.dk](http://www.wilmar.risoe.dk))
- Compare operational costs in three model runs:
  1. With stochastic wind power production
  2. With deterministic wind power production
  3. With constant wind power production
- 1 minus 2: Costs of partial predictability
- 2 minus 3: Costs of variability
- 1 minus 3: Integration costs of wind power
- Each model run covers 5 selected weeks



# Overview Planning tool

## Wilmar Planning Tool

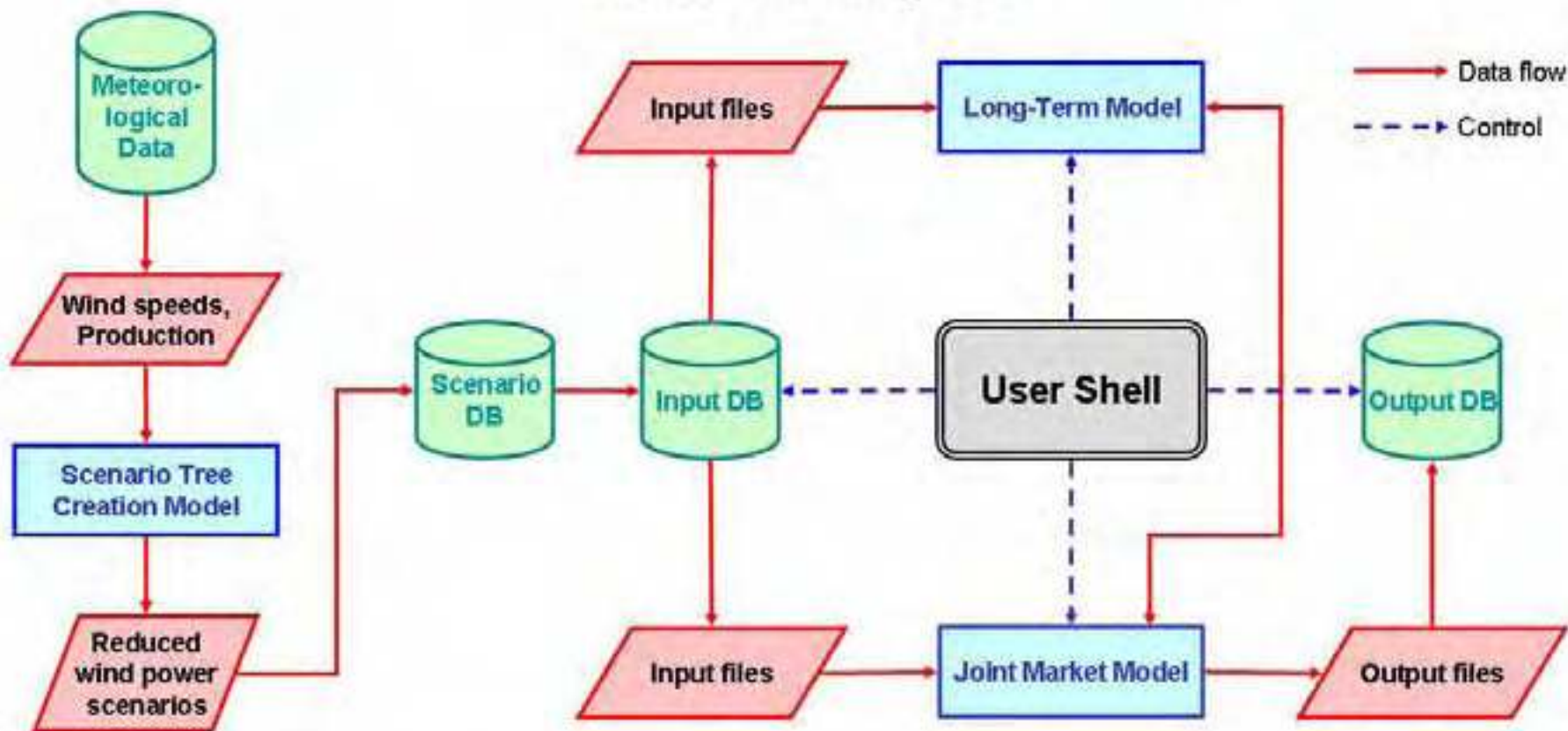

# Overview of the Planning Tool

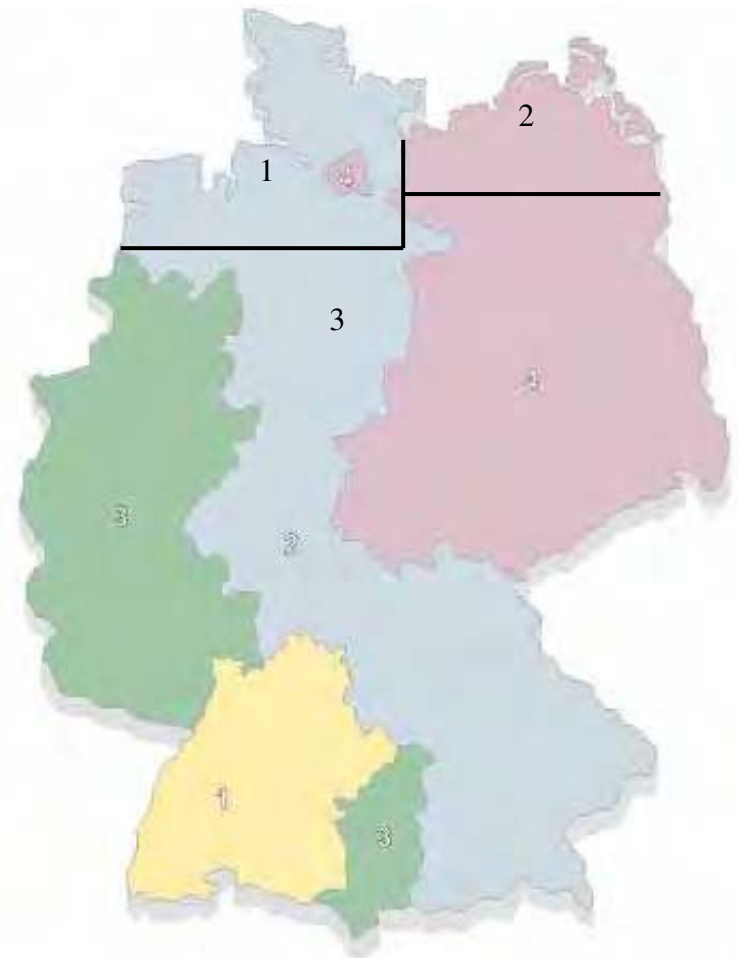
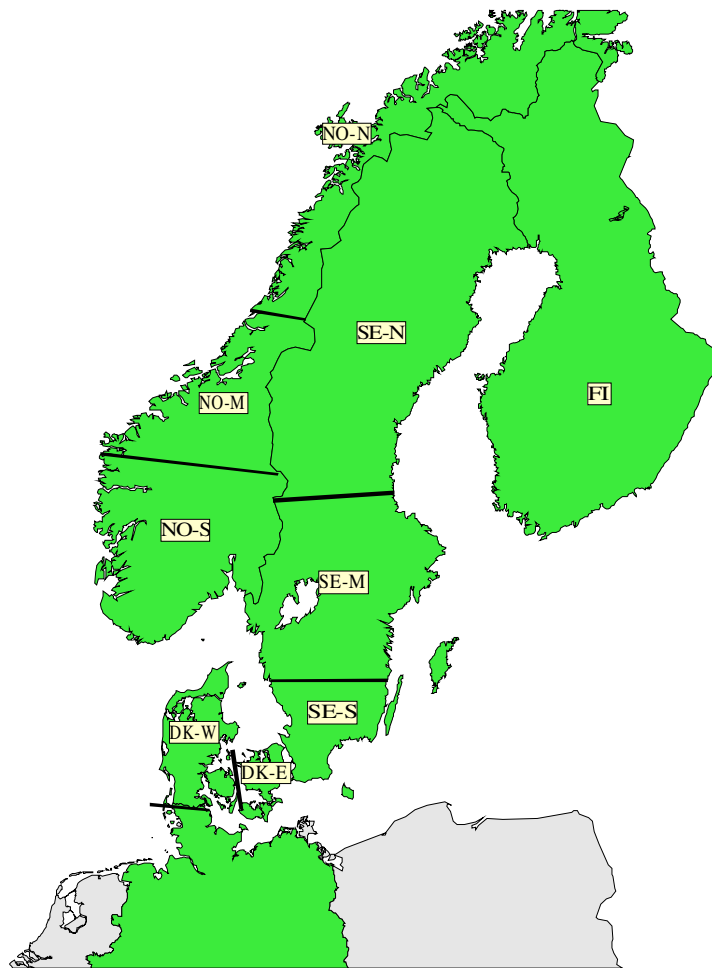

- 1 EnBW Transportnetze AG
- 2 E.ON Netz GmbH
- 3 RWE Net AG
- 4 Vattenfall Europe Transmission AG

# Design of Joint Market model

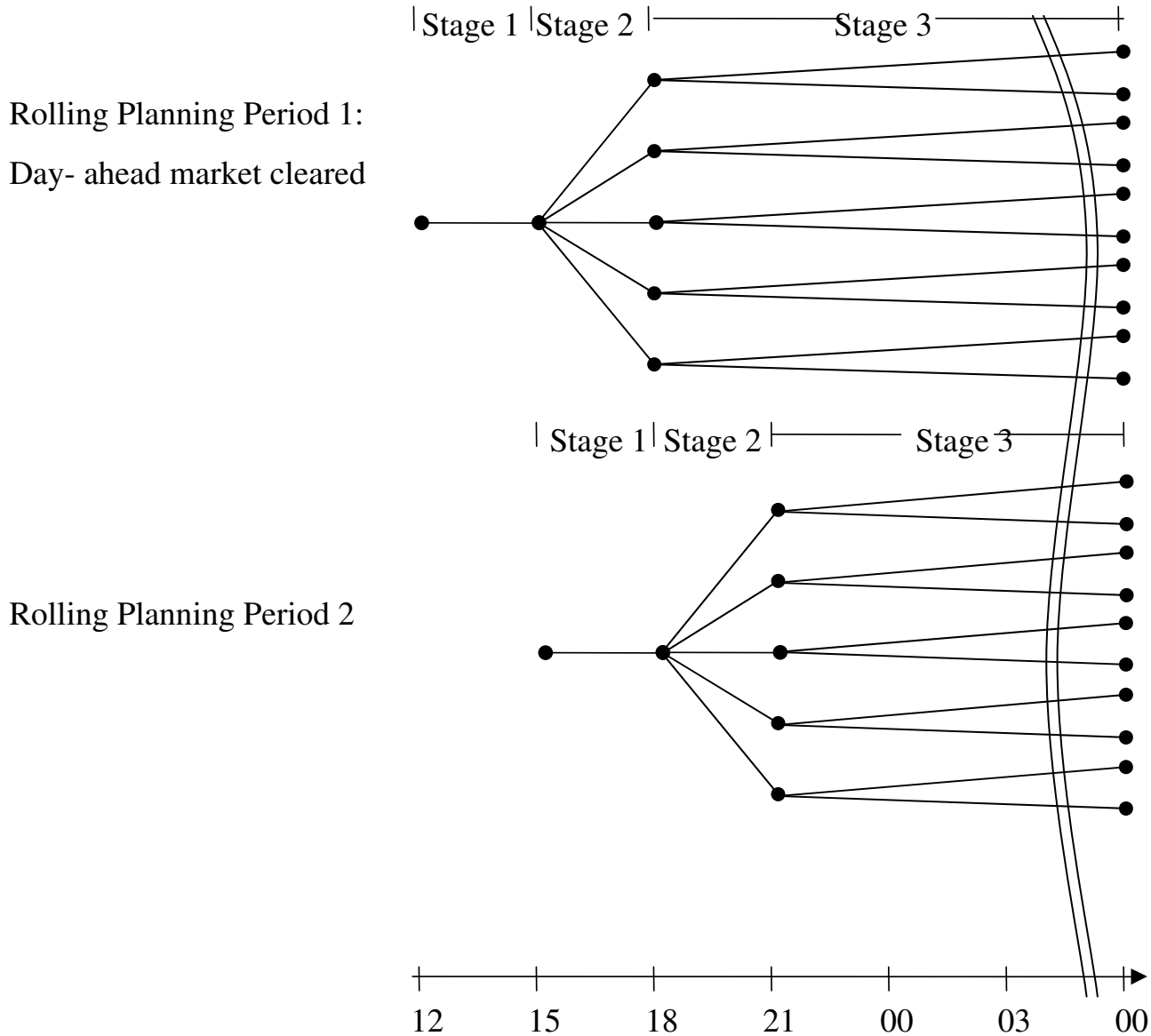

## Methodology

- 2010 power system configuration case:
  - Yearly load
  - Transmission lines
  - Power plants
  - Fuel prices
  - CO2 price
- Three cases for installed wind power

# Installed wind power capacity in each wind scenario

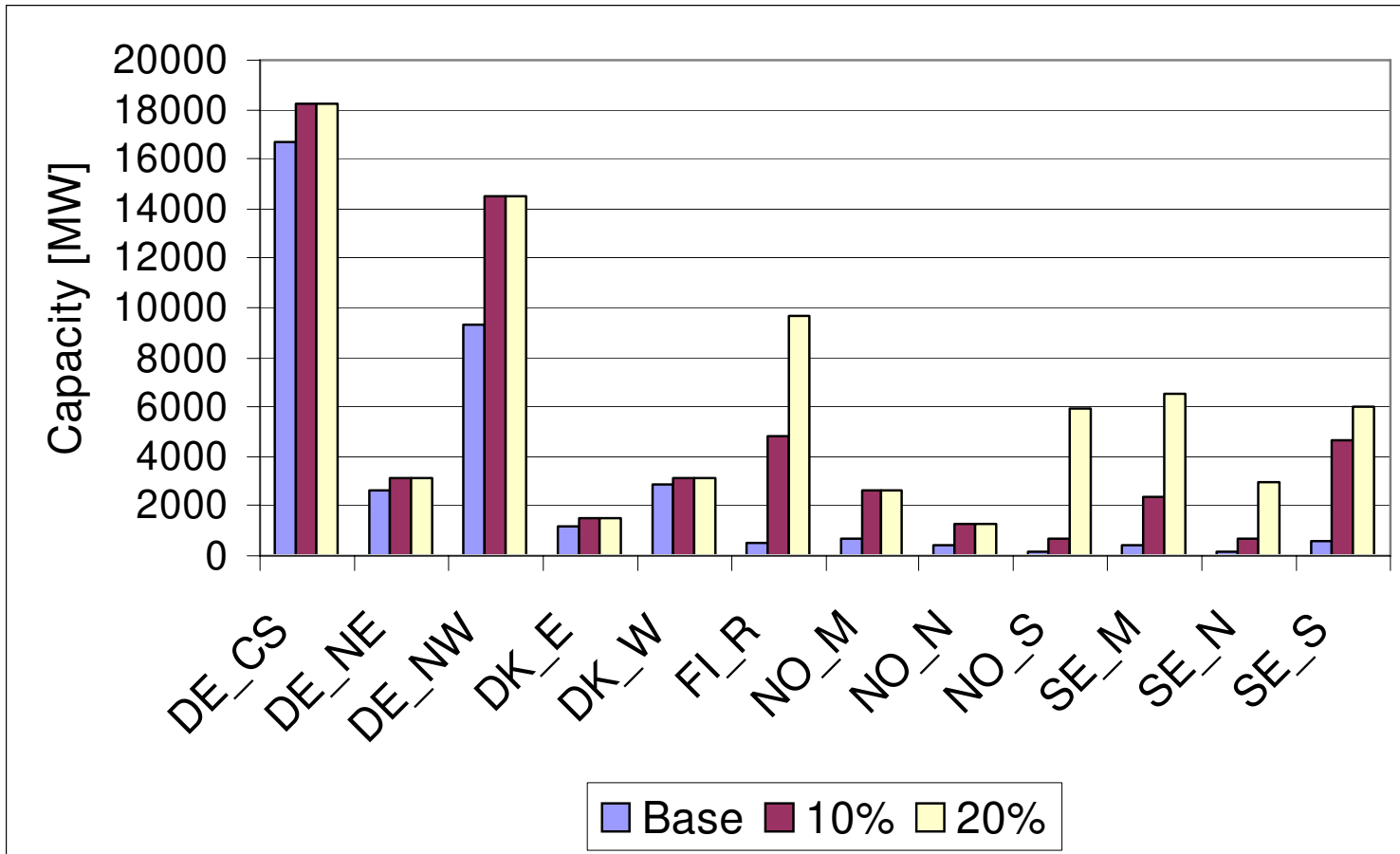

## Difference in system operation costs

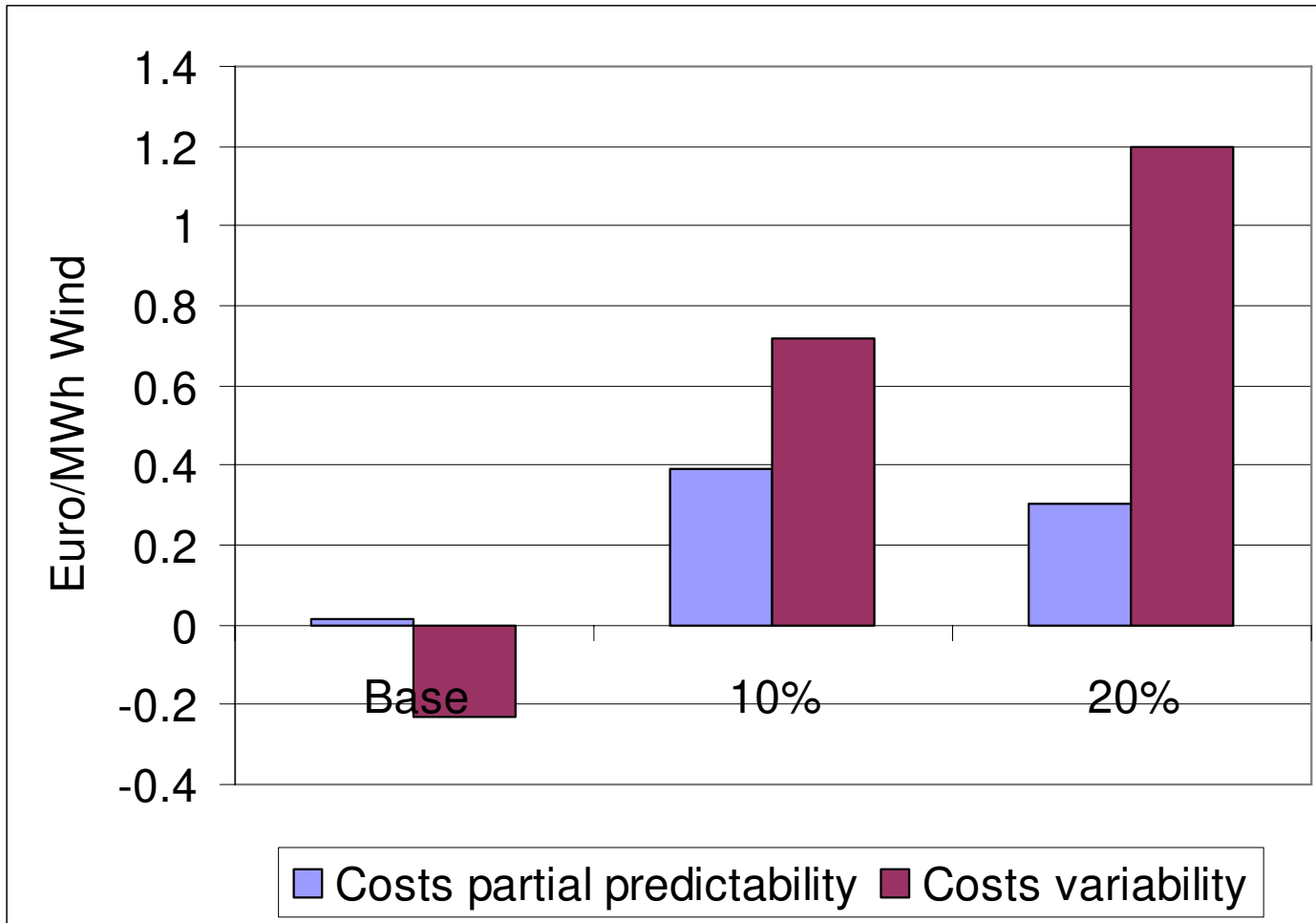

# Results

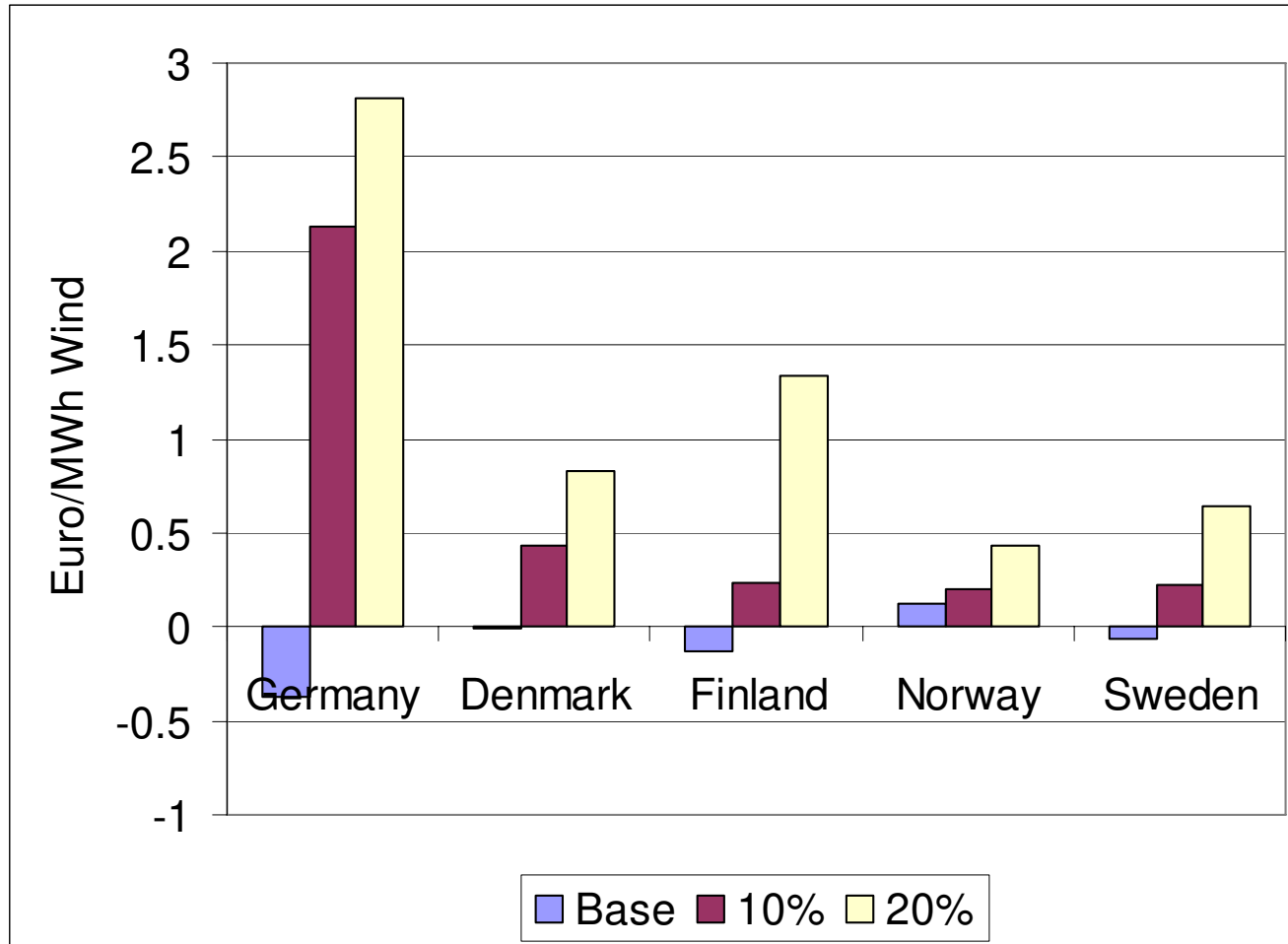

Difference in system operation costs per MWh wind power production for the three wind cases and divided on countries.

## Discussion

- Integration costs a ill-defined concept:
  - Involves comparison with a hypothetical power system configuration (e.g. constant wind power production)
  - What can the information be used for?
- We should use comparison of system costs and benefits in stead:
  - Power system configurations with different amounts of wind
  - Comparison should include:
    - Investment costs (grid and plants)
    - Operational costs
    - Emissions (CO<sub>2</sub>, ...)
    - Different scenarios for fuel prices and CO<sub>2</sub>
    - Security of supply



## Outlook

- The development and usage of the Wilmar Planning tool is continued in
  - SUPWIND: EU sixth framework programme project, [www.supwind.risoe.dk](http://www.supwind.risoe.dk)
  - All-Island Grid study: Irish wind integration study
  - Anemos-plus: EU sixth framework programme project
- Model developments:
  - Load uncertainty
  - Forced outages
  - Unit commitment with mixed integers
  - Interaction with investment model
- Case studies:
  - Irish case
  - New Nordic and German cases
  - Probably other European cases

# A COOLING SYSTEM FOR BUILDINGS USING WIND ENERGY

Hamid Daiyan  
*Azad University-Semnan Branch, Iran*

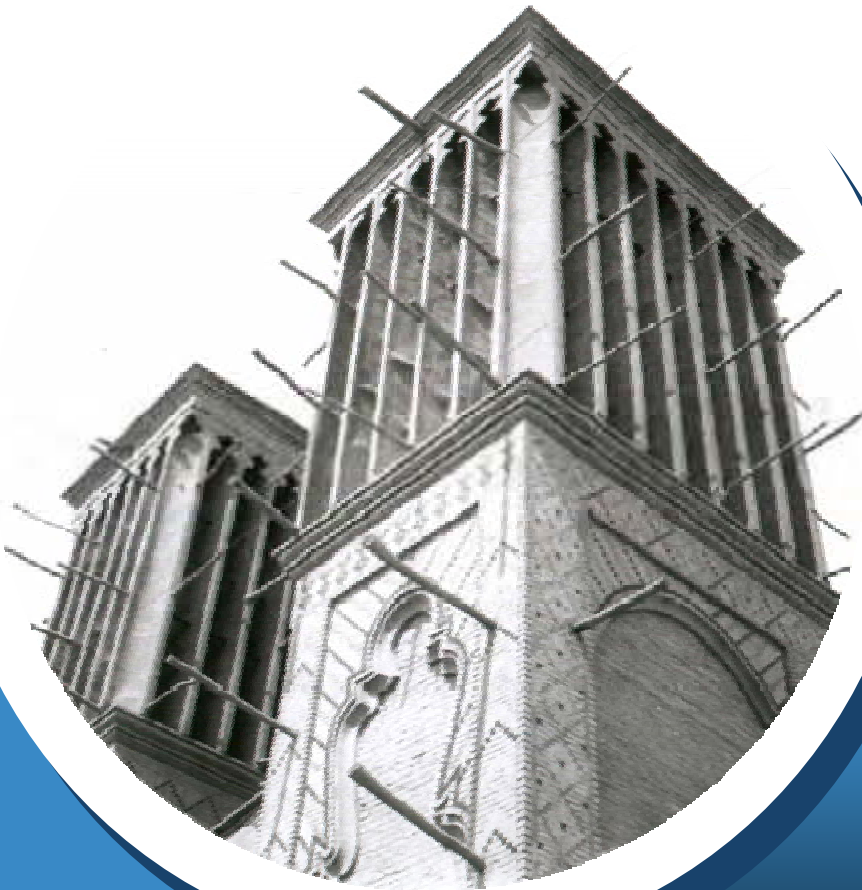

Risø International Energy  
Conference 2007

Risø National Laboratory  
22- 24 May 2007  
Denmark



# Contents



**Introduction**

**Kind Of Wind Tower**

**Function of Wind Tower**

**Case Study**

**Conclusion**

# Introduction

In Iranian historical architecture wind tower is used for cooling and ventilation. Wind tower is a tall structure that stands on building. Wind tower is used in dray land, and only uses wind energy for conditioning.



# Introduction

Its technologies date back over 1000 years. Wind towers were designed according to several parameters, some of the most important of which were building type, cooling space volume, wind direction and velocity and ambient temperature.



# Introduction



Wind tower of Doulat-Abad garden of Yazd with its altitude is 33 meters and 80 centimeter. It is highest wind tower in Iran. It has built in 1750. This wind tower has octagon plan. It can receive wind from eight directions and conduct it inside of room.

1) Square and octagon wind tower is suitable for regions that direction of pleasant wind is various, specially in the warm seasons that some times pleasant wind blows from north to south and some times from east to west.



*An octagon wind tower in Yazd*

2) Rectangular wind tower has built in the area that direction of wind is from north-east to south-west. For this reason architectures make it in front of big surface of outward appearance.



*A rectangular wind tower in Semnan*



3) In the villages of edge of desert and villages of inside of desert to avoid harm of whirlwind and storm architectures make it only direction, it has made north-east and other sides have been closed. Its direction is to the mountain breeze.

# Function of Wind Tower

Function of wind tower basically constructed method of utilization from blowing of wind to take pleasant air in to building and use from its reflection energy to suck for drive away hot and polluted weather.

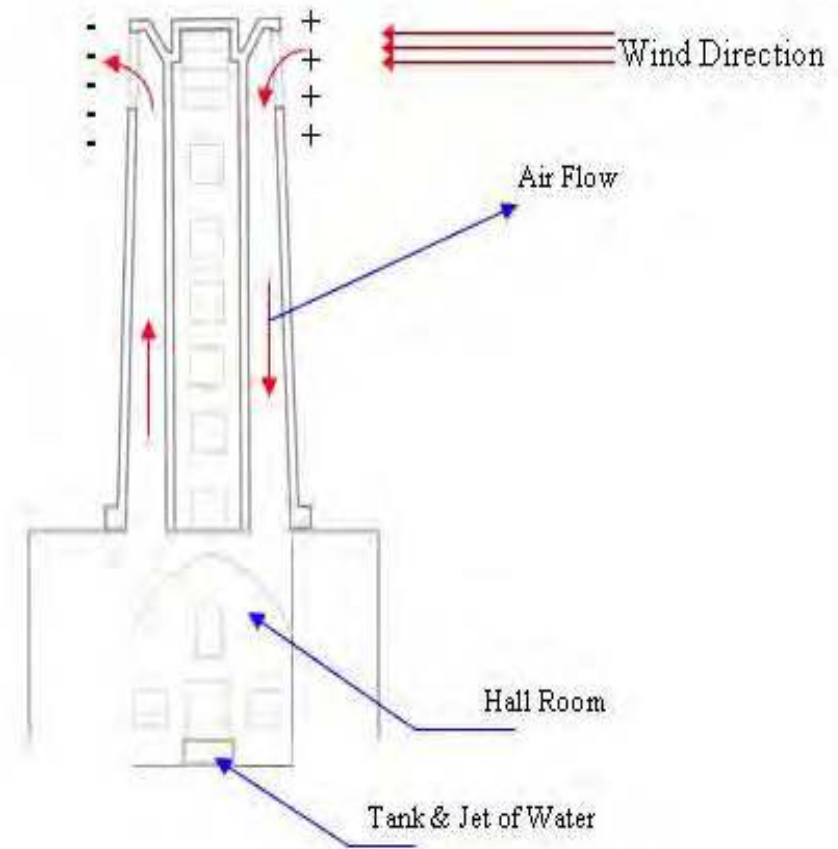

# Function of Wind Tower



Dry weather that wind tower receives path above of little pool and fountain it becomes cool by method of evaporation and goes into the room.

# Case Study

This section indicates conclusion of inside and outside temperature of building that has equipped wind tower in one of summer hot day. This specimen ventilation has been made about 135 years ago in south of Semnan it's high is 20 meters. It is highest wind tower of Semnan.



# Case Study

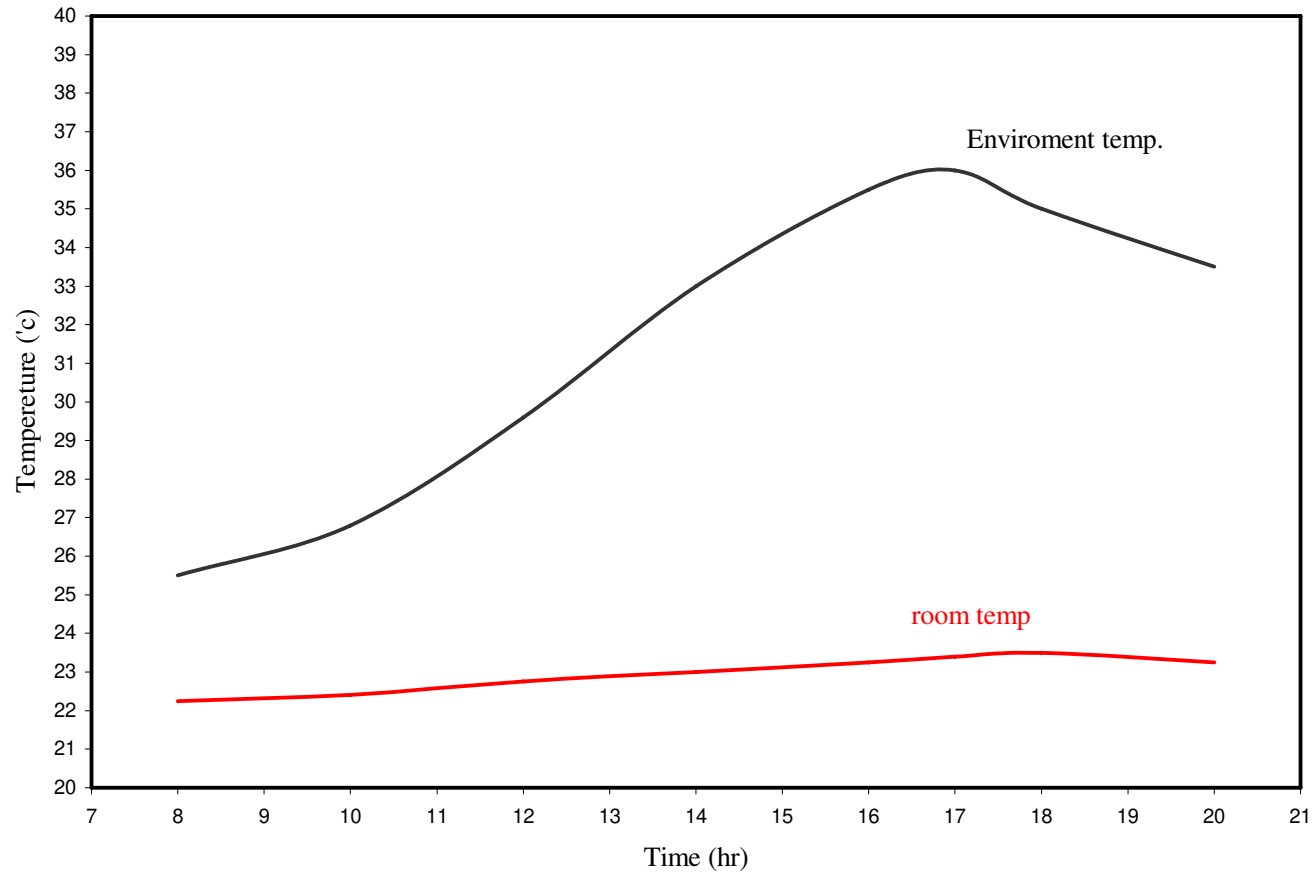

Room temperature comparison

# Conclusion

As shown in above graph wind tower can moderate weather of room. Other important point is fixing temperature of room and keeps it in suitable situation. Above graph shown average degree of environment in the outside is  $32^{\circ}c$  and average temperature of room is  $23^{\circ}c$  . It is desirable weather in the warm area.

Thank you very much for your attention



Risø International Energy  
Conference 2007

Risø National Laboratory  
22- 24 May 2007  
Denmark

# Energy Demand Patterns

## The Effects Substitution and Productivity

Nico Bauer

Potsdam Institute for Climate Impact Research (PIK)





# Contents

- Production theory
  - Substitution
  - Biased technological change
  - Separability
- Econometric framework
- Results
- Discussion and further research

# Contents

- **Production theory**
  - Substitution
  - Biased technological change
  - Separability
- Econometric framework
- Results
- Discussion and further research

# Contents

- **Production theory**
  - **Substitution**
  - **Biased technological change**
  - Separability
- Econometric framework
- Results
- Discussion and further research

# Contents

- **Production theory**
  - **Substitution**
  - **Biased technological change**
  - **Separability**
- Econometric framework
- Results
- Discussion and further research

# Contents

- Production theory
  - **Substitution**
  - **Biased technological change**
  - Separability
- **Econometric framework**
- Results
- Discussion and further research

# Contents

- Production theory
  - **Substitution**
  - **Biased technological change**
  - Separability
- Econometric framework
- **Results**
- Discussion and further research

# Contents

- Production theory
  - Substitution
  - **Biased technological change**
  - **Separability**
- Econometric framework
- Results
- **Discussion and further research**

# Production Theory

- Aggregate production function  $f()$ 
  - Output  $y$
  - Inputs  $x$
  - Prices  $p$

$$y = \left[ (a_1 x_1)^\rho + (a_2 x_2)^\rho \right]^{1/\rho}; \quad \sigma = (1 + \rho)^{-1} = - \frac{\partial x / x}{\partial p / p}.$$

- Optimal Factor Allocation
  - Marginal productivities equal prices

$$p_i = \frac{\partial y}{\partial x_i} \quad \Leftrightarrow \quad x = \tilde{f}(p).$$



# Production Theory

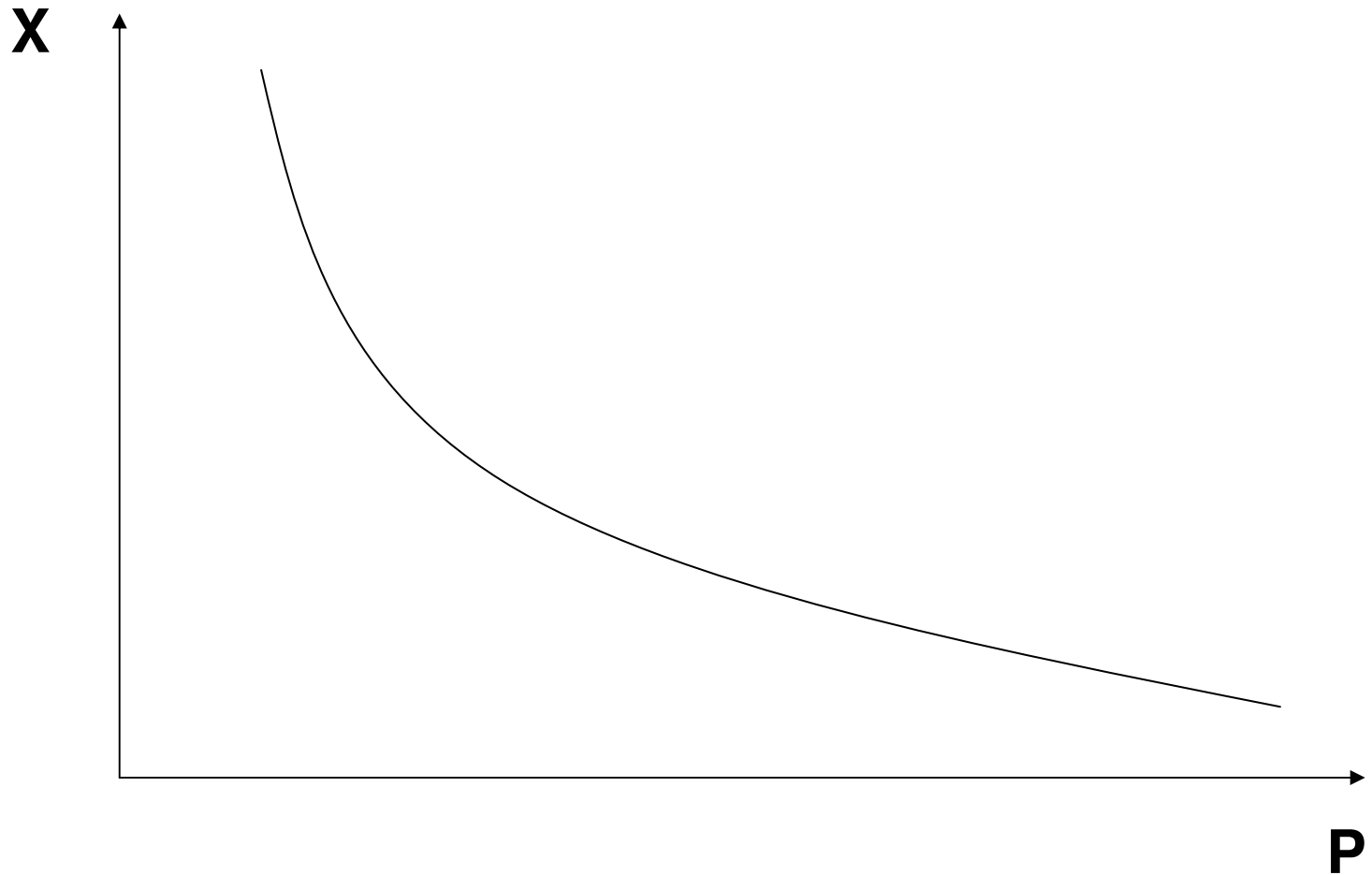

# Production Theory

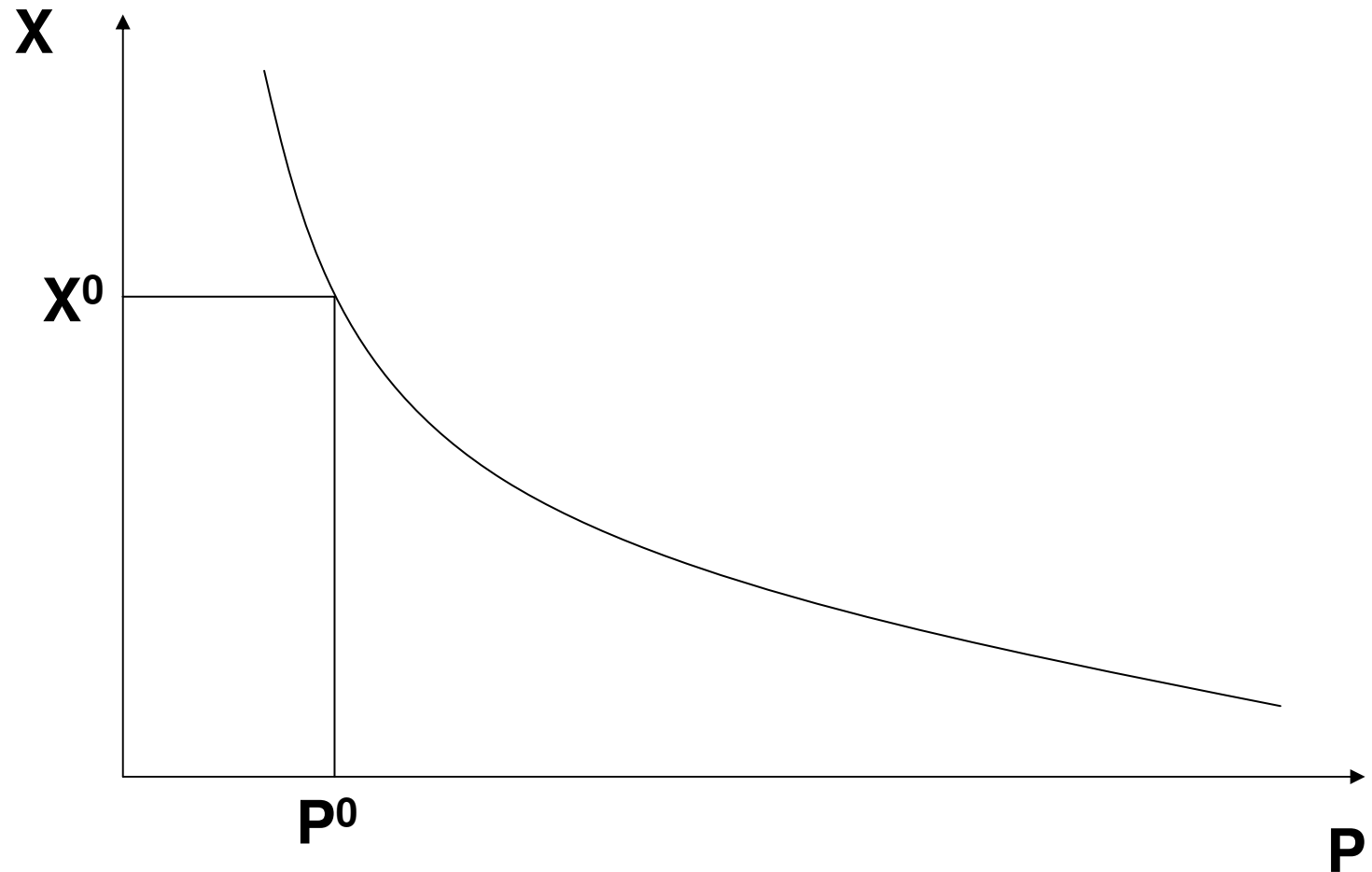

# Production Theory

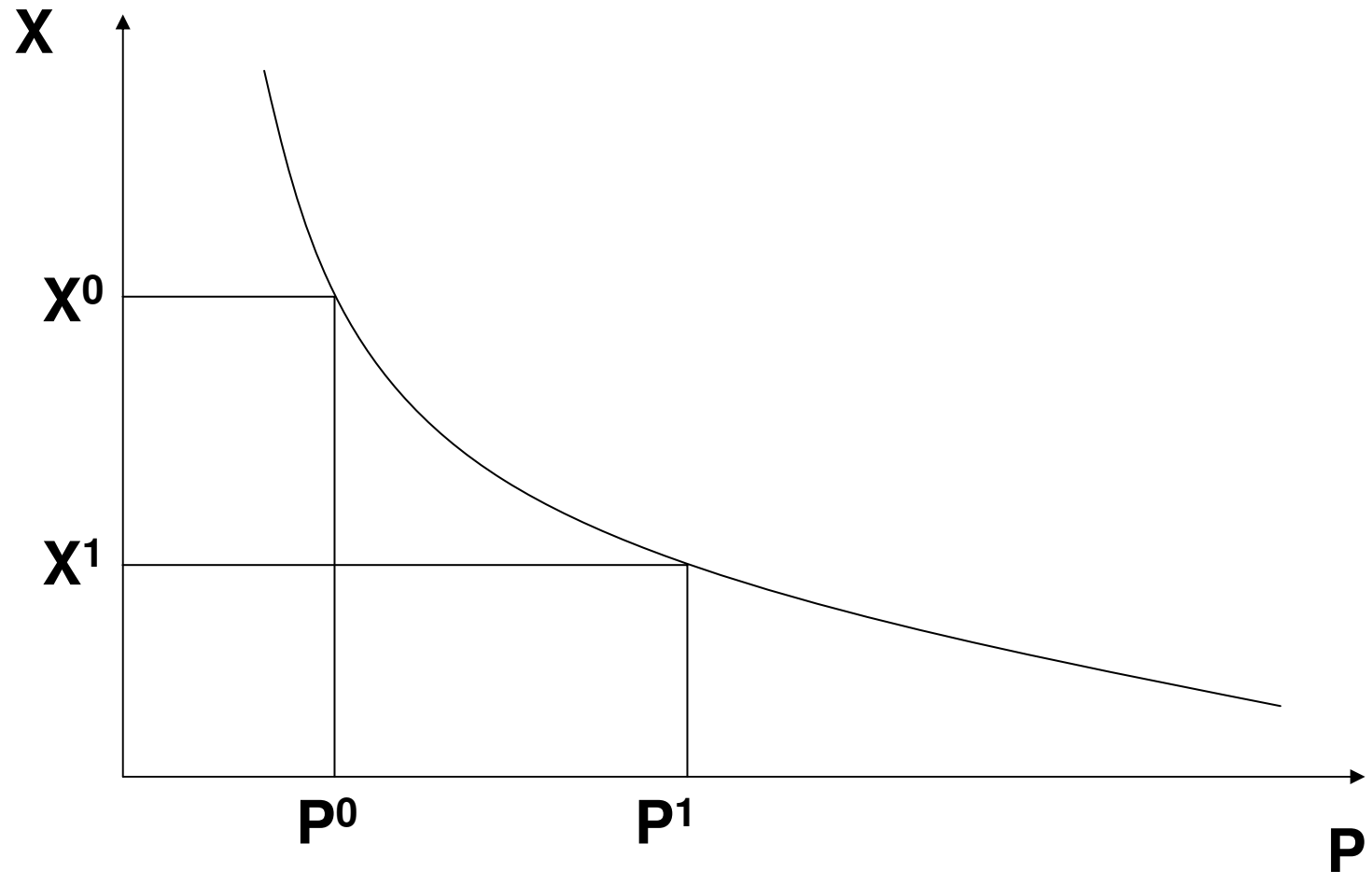

# Production Theory

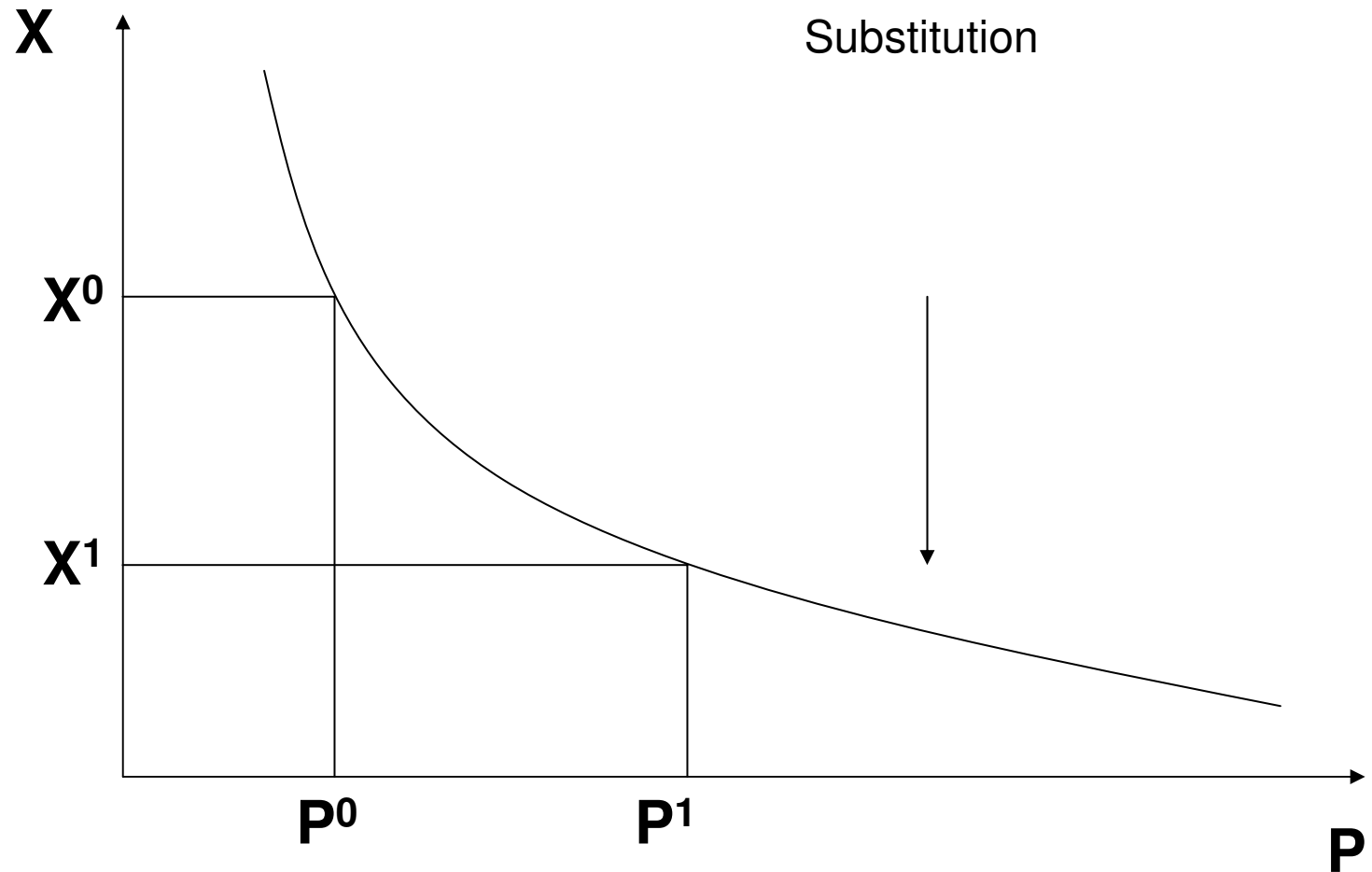

# Production Theory

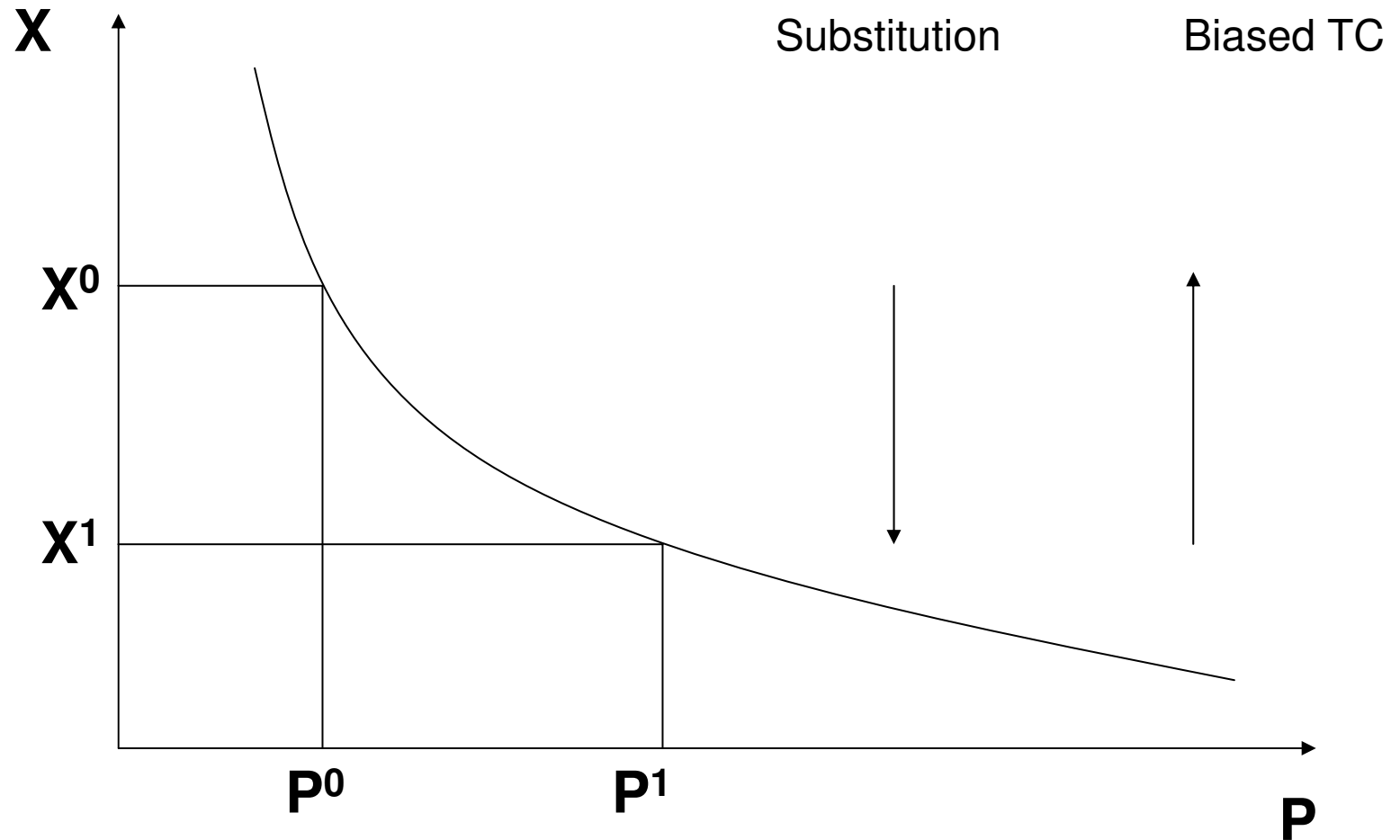

# Production Theory

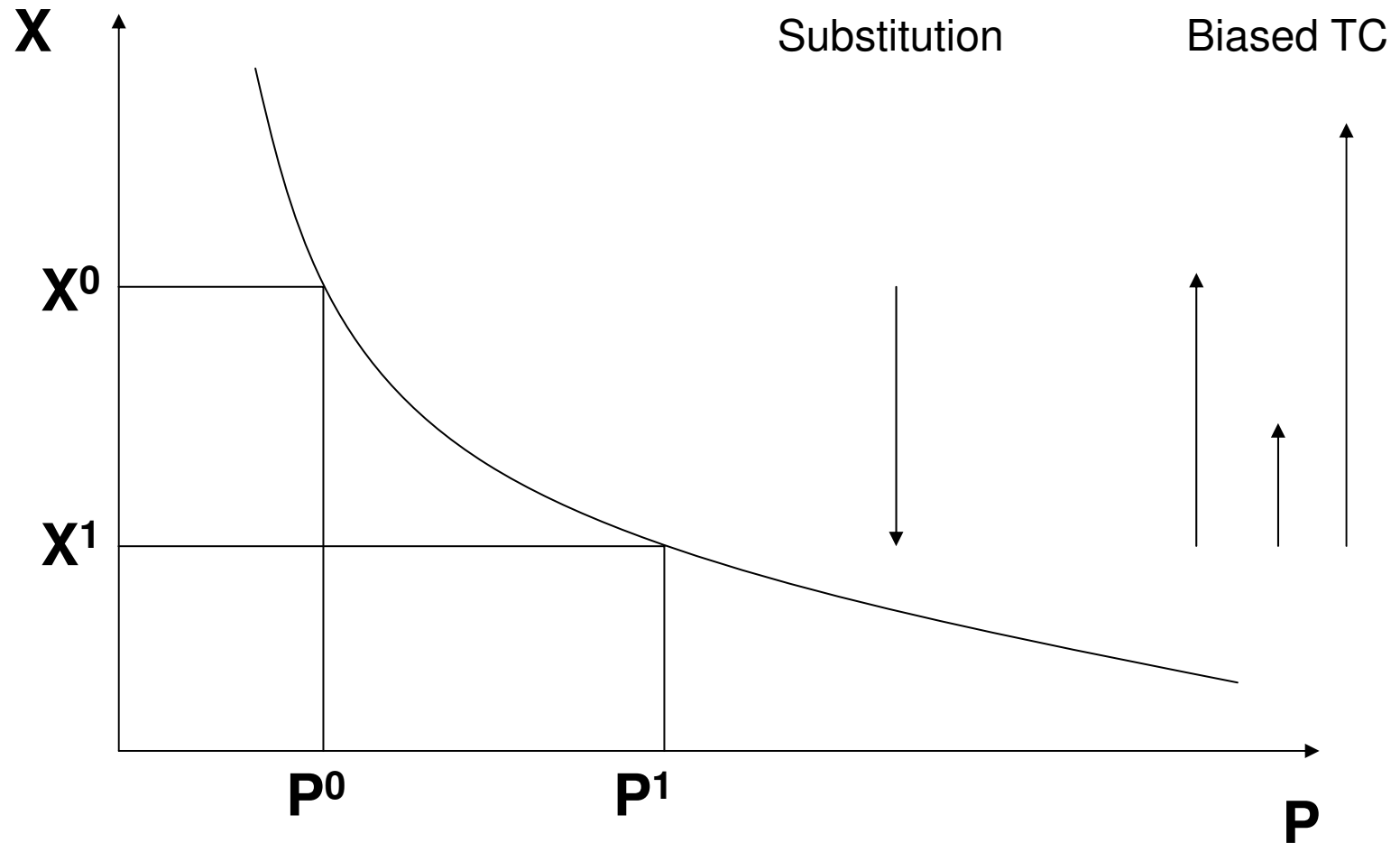

# Production Theory

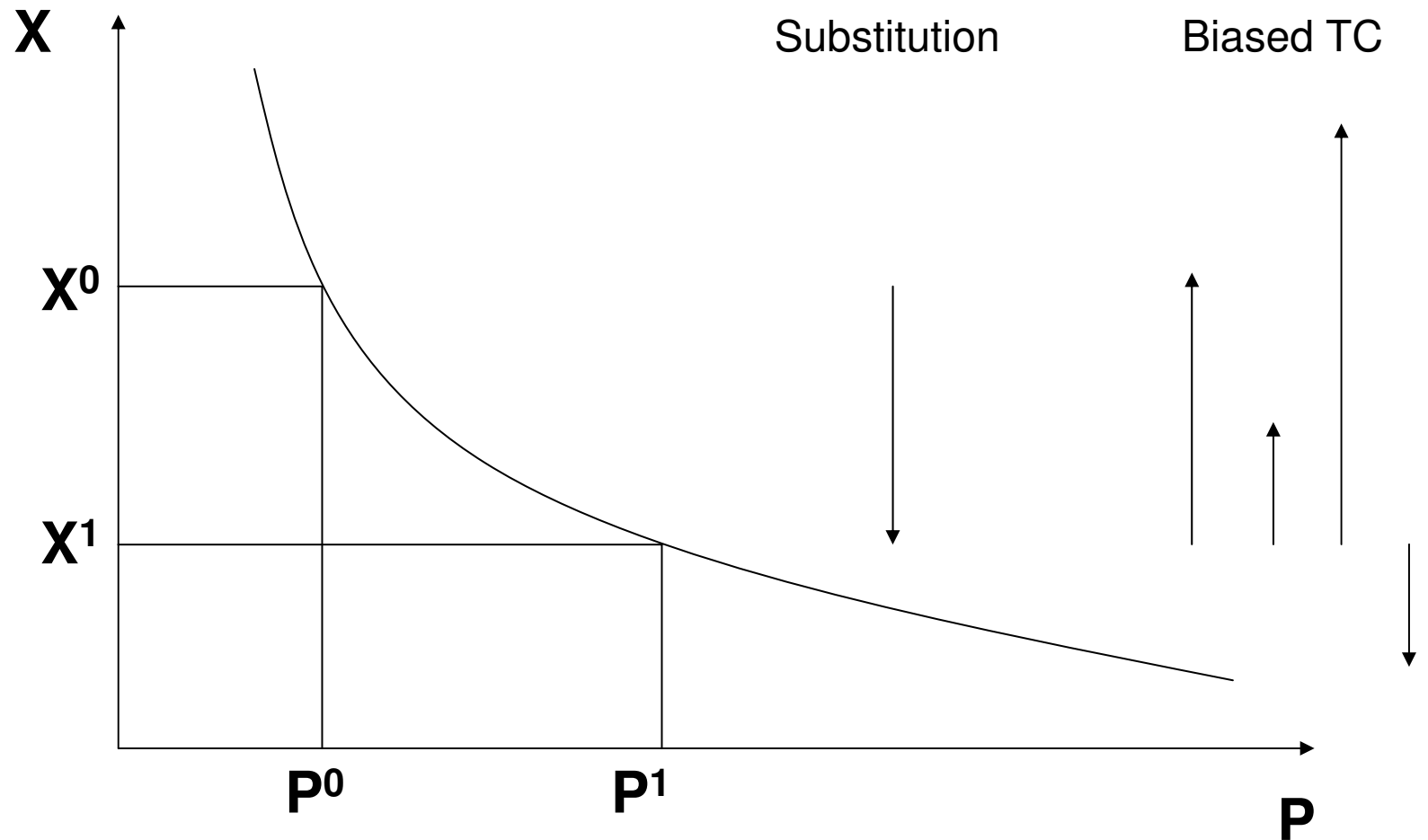

# Production Theory

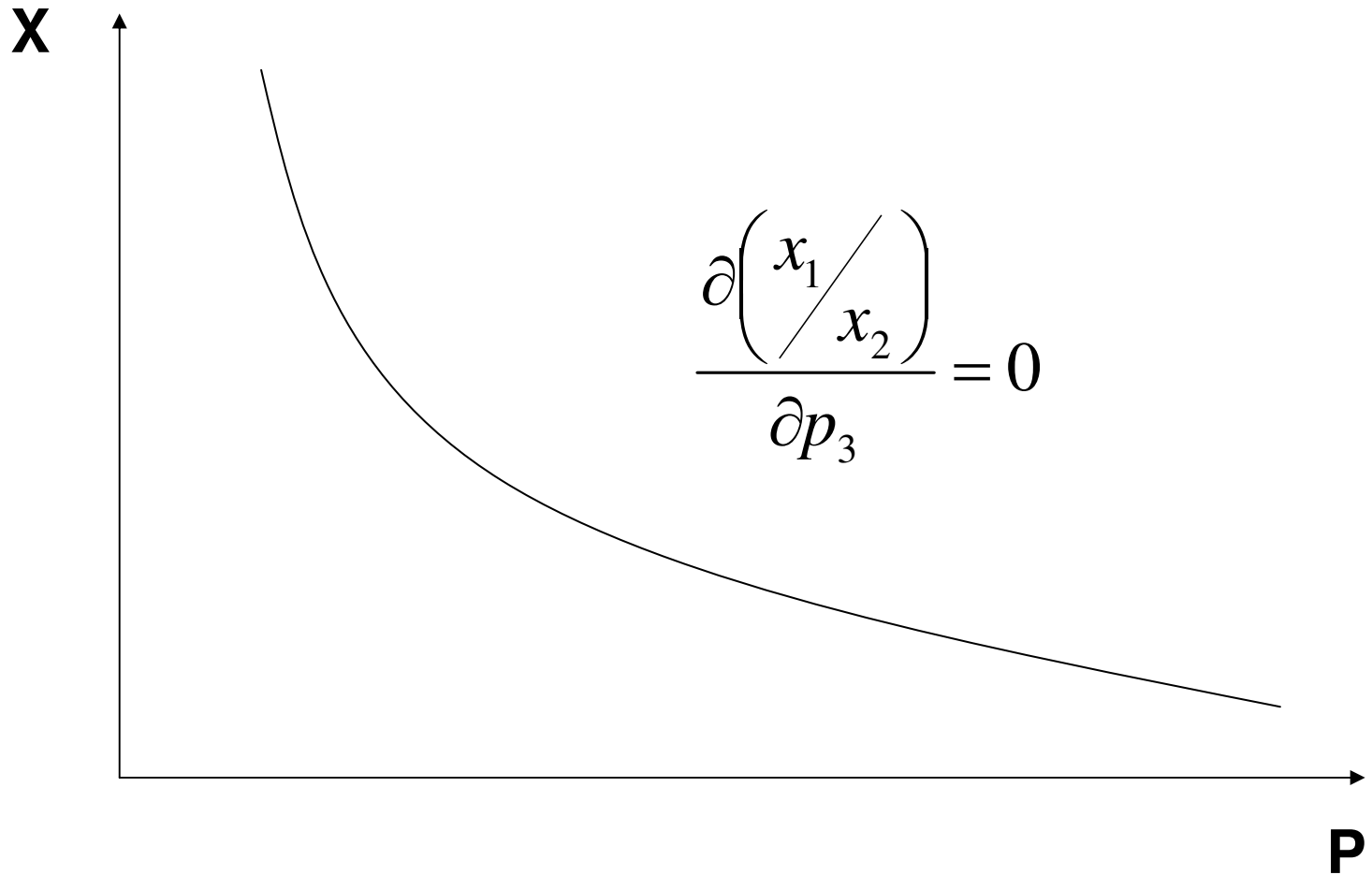



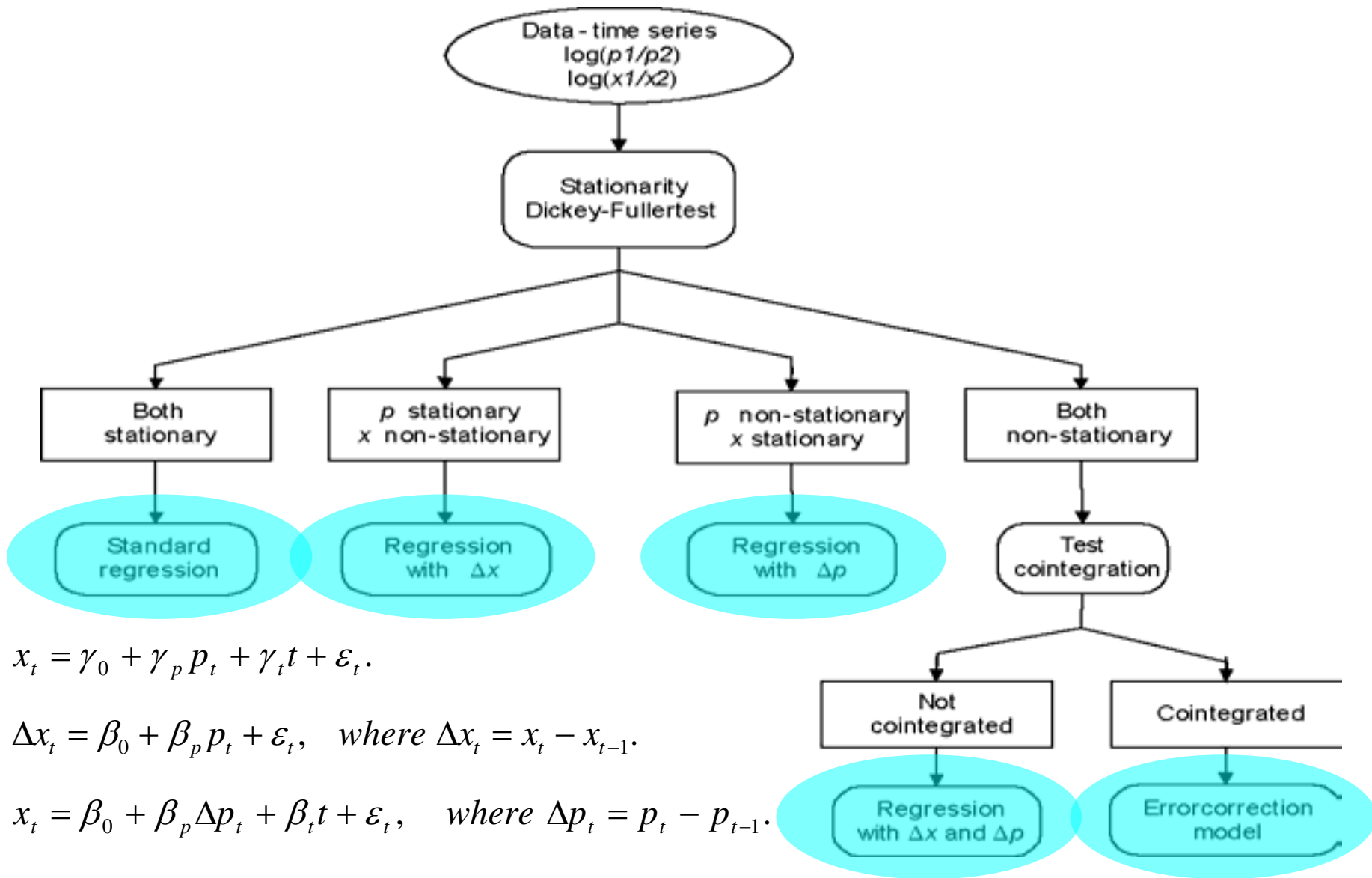

$$x_t = \gamma_0 + \gamma_p p_t + \gamma_t t + \varepsilon_t.$$

$$\Delta x_t = \beta_0 + \beta_p p_t + \varepsilon_t, \quad \text{where } \Delta x_t = x_t - x_{t-1}.$$

$$x_t = \beta_0 + \beta_p \Delta p_t + \beta_t t + \varepsilon_t, \quad \text{where } \Delta p_t = p_t - p_{t-1}.$$

$$\Delta x_t = \beta_0 + \beta_p \Delta p_t + \varepsilon.$$

$$\Delta x_t = \beta_0 + \beta_p \Delta p_t + \beta_e (x_{t-1} - \gamma_0 - \gamma_p p_{t-1} - \gamma_t t) + v_t.$$

# Results – Overview

- Nearly all energy ratios are trended; not so much price ratios
- High share of ratios is non-stationary  
→ models with differences
- Substitution: rarely significant
- BTC: significant with many structural breaks

# Results – Gas-Oil

- Trend to gas → Ö, Bel, CH, J, NL, SP
  - Slowed down → Cz93, F85, D85, I92, UK89
  - Switch to oil → SI92, USA88
  - Trend to oil → Mex
- 
- 3 of 24 substitution parameters significant, ...
  - One having the wrong sign.

# Results – Gas-Coal

- Trend to coal → Bel
  - Trend to gas → F, J, SI, US
  - Accelerated → CH91, D89, UK92
  - Slowed down → Cz92
  - Switch to gas → Ö85, I85
  - Switch to coal → T93
- 
- 2 of 21 substitution parameters significant

# Results – Oil-Coal

- Trend to coal → Ö, Bel, NL, Nor
- Trend to oil → Cz, J, UK, SI
- Switch to oil → CH87, F90, D89, I85, US91
  
- 6 of 22 substitution parameters significant, ...
- One having the wrong sign.

# Discussion

- Low evidence for substitution
- High evidence for BTC; structural breaks
- Countries show different patterns
- What may explain BTC?

# Discussion

- Investments and depreciation re-structure capital stock
- Changes relative energy demands
- Investments determined not only by energy prices
- Contradiction with separability assumption!
- BTC can capture changed energy demand due to capital stock restructuring
- Problem: how to endogenise BTC?

# Further Research

- Improvement of data
  - Sectoral resolution
  - Investment data
- Theoretical analysis
  - Bottom-up vs. top-down → capital theory
  - Separability and BTC
- Integrated modeling
  - Pragmatic approach: exogenous BTC
  - Scenarios, sensitivity analysis





# **STREAM: A Model for a Common Energy Future**

Risø Energy Conference, 24 May 2007

Peter Markussen  
DONG Energy Generation

# Background



- The future Danish Energy System (2004-2007)
- Initiated by The Danish Board of Technology
  - Public body established by the Danish parliament
- Project content
  - Open scenario process
  - Quantification of scenarios
  - [www.tekno.dk](http://www.tekno.dk)

# Goal of the project



- Lay dawn objective and possible futures for the Danish Energy System
- Steering group to agree on the process and overall goals for scenarios
  - 10 interested parties from the energy sector and NGO's
- Working group to supply a modeling tool and facts:
  - Mette Behrmann, Jens Pedersen (Energinet.dk)
  - Kenneth Karlsson (Risø)
  - Anders Kofoed-Wiuff, Jesper Werling (EA Energianalyse)
  - Peter Markussen (DONG Energy)

# Agenda



1. The scenario process
2. The results
3. The modelling tool
  - Energy savings model
  - The time series model
  - The energy flow model
4. Perspectives

# Agenda



1. The scenario process
2. The results
3. The modelling tool
  - Energy savings model
  - The time series model
  - The energy flow model
4. Perspectives



# The scenario process

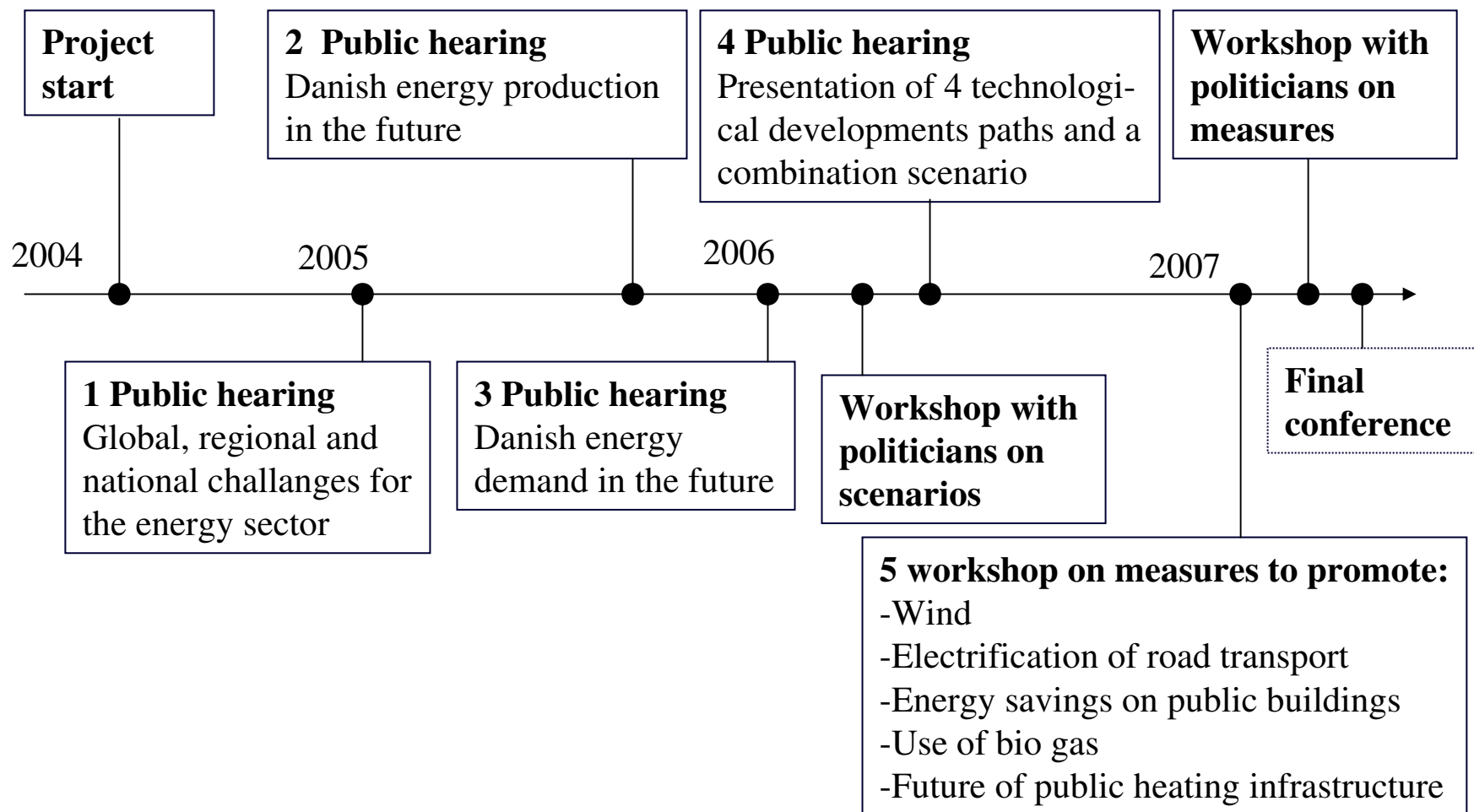

# Quantitative targets



- Reduce CO2 emissions by 50% in 2025 compared to 1990
- Reduce oil consumptions by 50% in 2025 compared to 2003
- Take into account global responsibility and national economics

# Agenda



1. The scenario process

2. The results

3. The modelling tool

- Energy savings model
- The time series model
- The energy flow model

4. Perspectives



# 4 technological scenarios to 2025

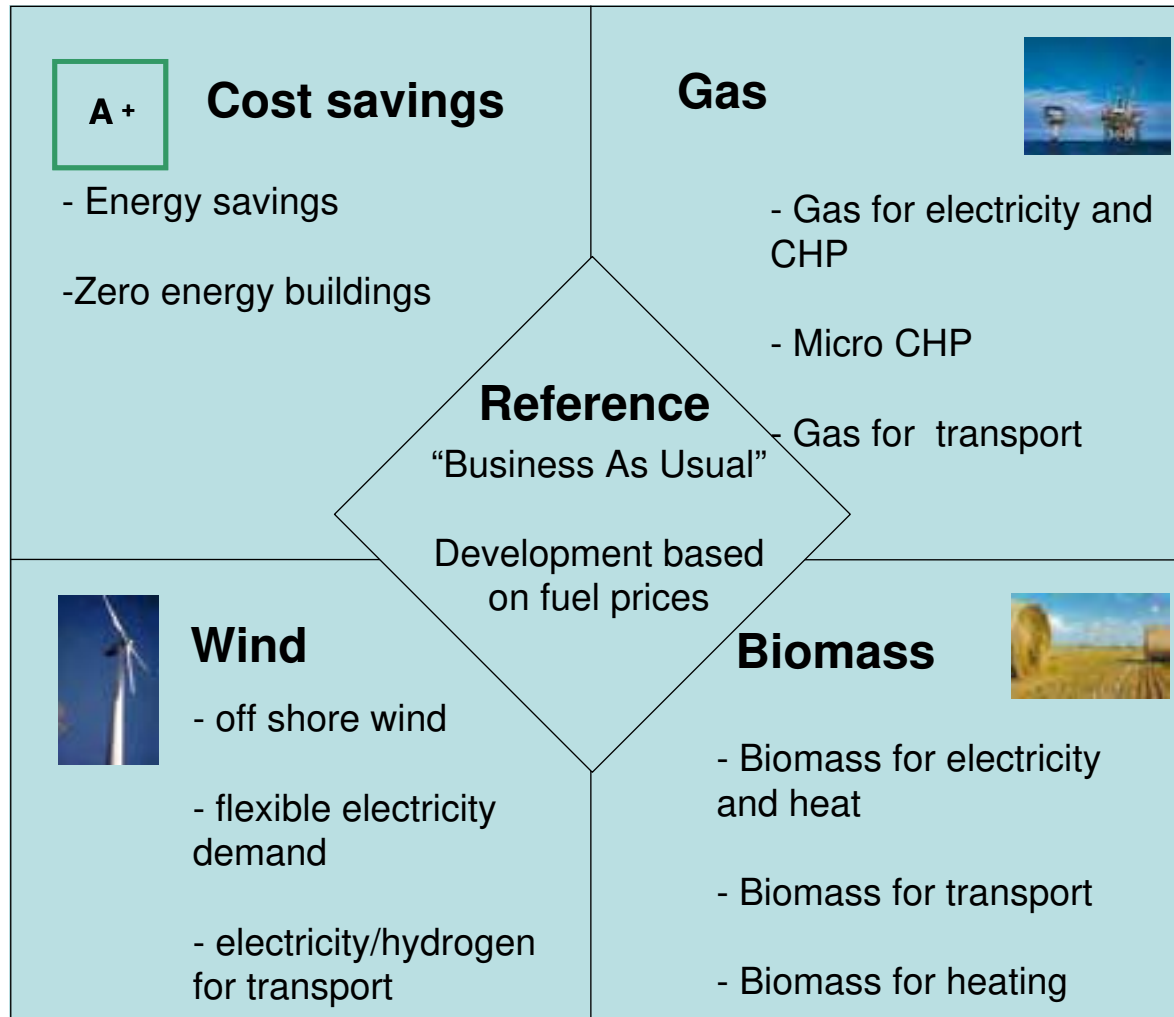

# The Combination scenario



- Combination of the 4 technology scenarios
- Inspiration from the workshop with politicians
- Savings and increased electricity production from wind and biomass for transport. Gas as back up for wind.

# The Combination Scenario

## Fuel use

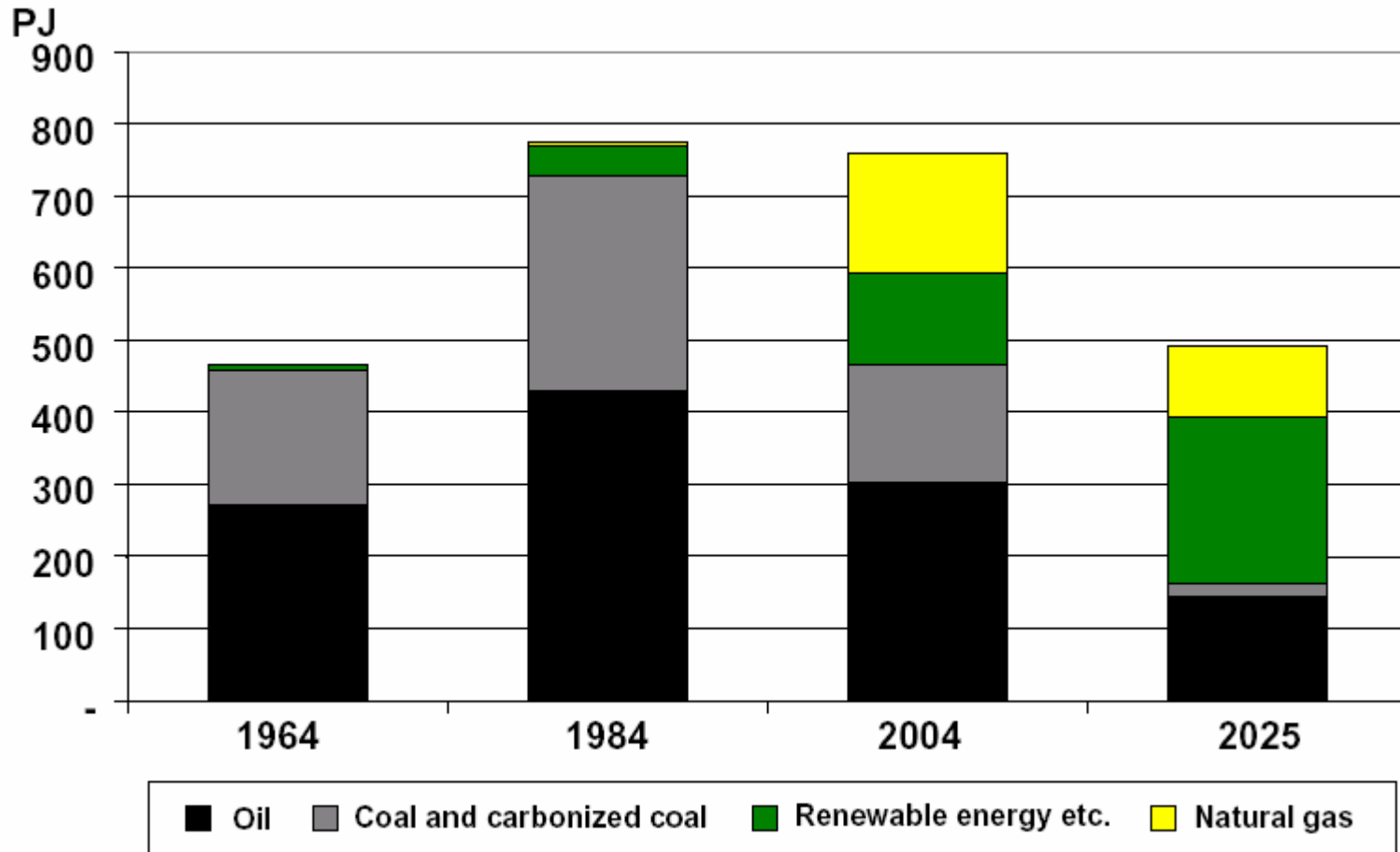

# The Combination Scenario CO2 emissions



Million tons CO2

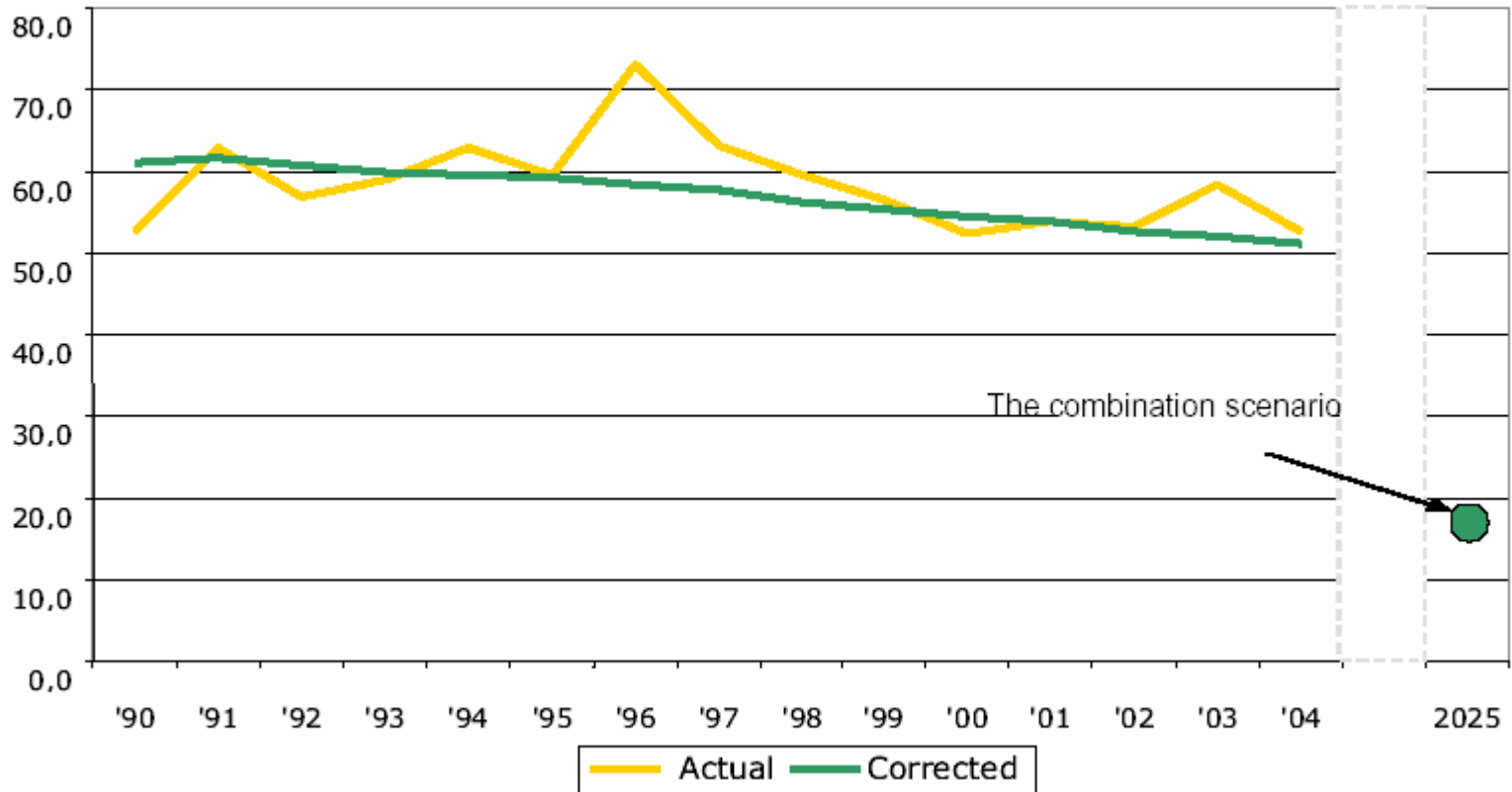

# The Combination Scenario

## Import/export balance

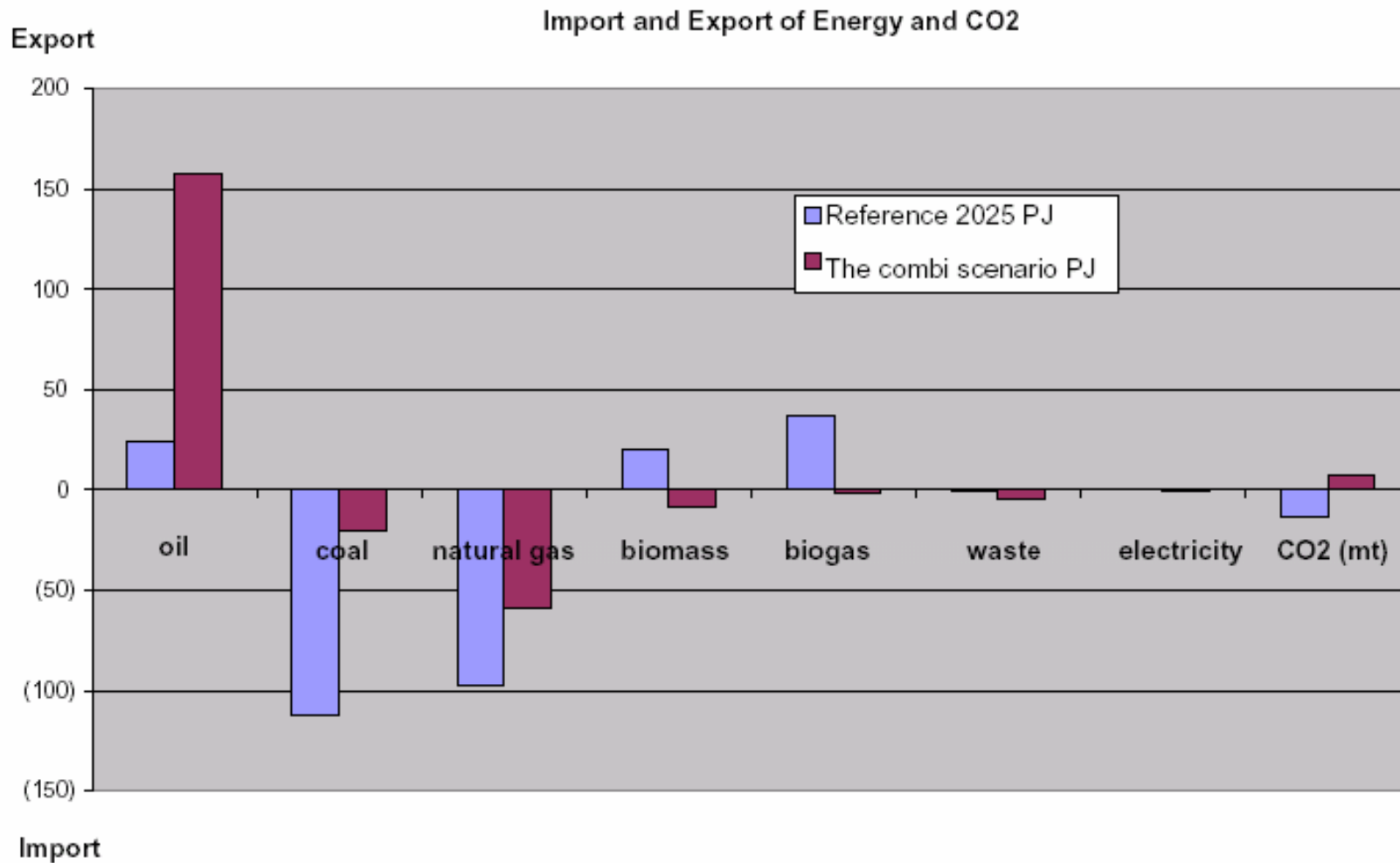

# The Combination Scenario

## National economics

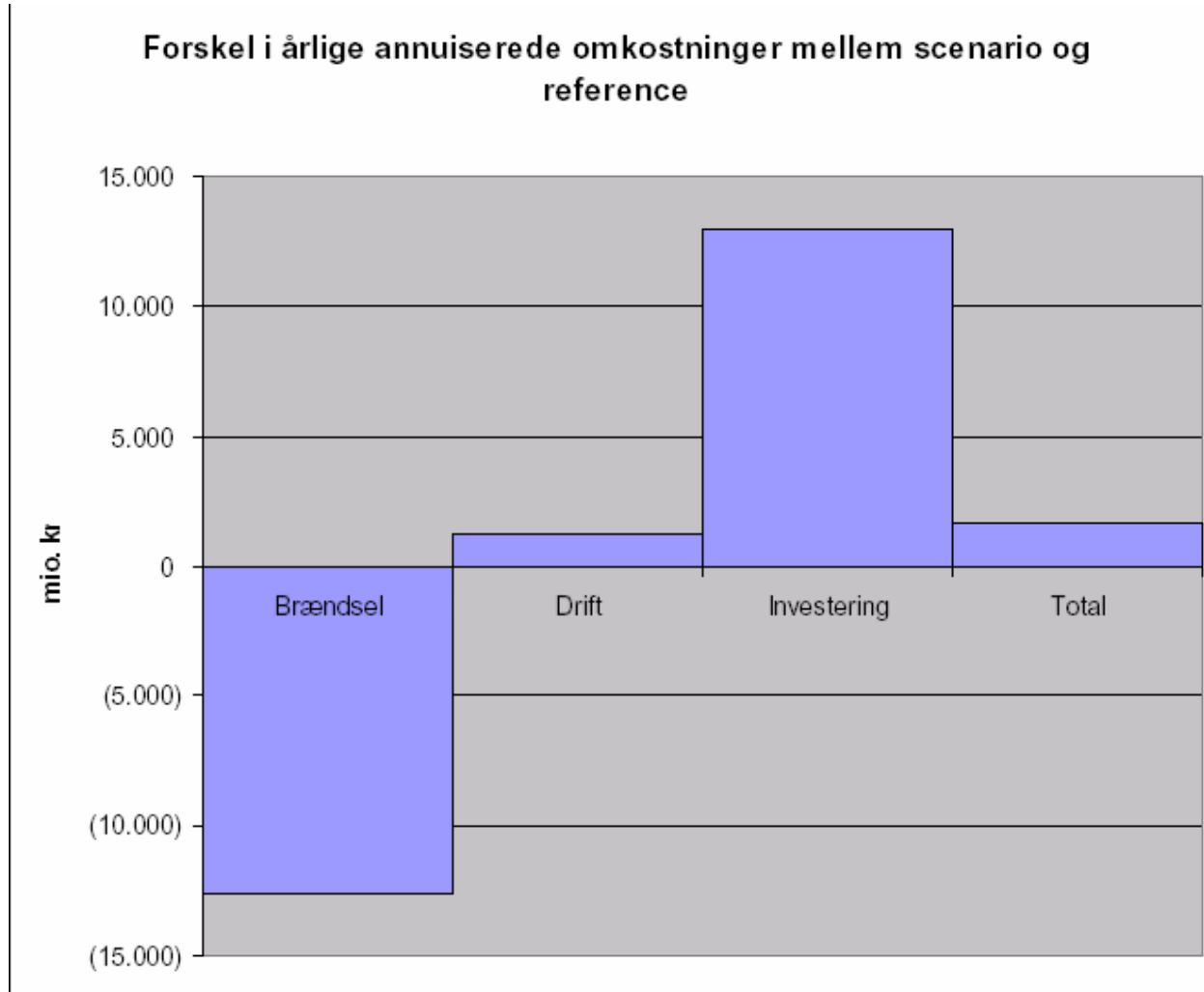

# Agenda



1. The scenario process

2. The results

3. The modelling tool

- Energy savings model
- The time series model
- The energy flow model

4. Perspectives

# The modeling tool: STREAM



- STREAM: Sustainable Technology, Research and Energy Analysis Model
- Simple and transparent model
  - Enhance complete energy flow
  - Developed in cooperation with broad range of parties
  - Conduct new analysis quickly
- Qualify scenarios through quantification
- Give project attendants better insight on the spot in scenario discussions



# STREAM

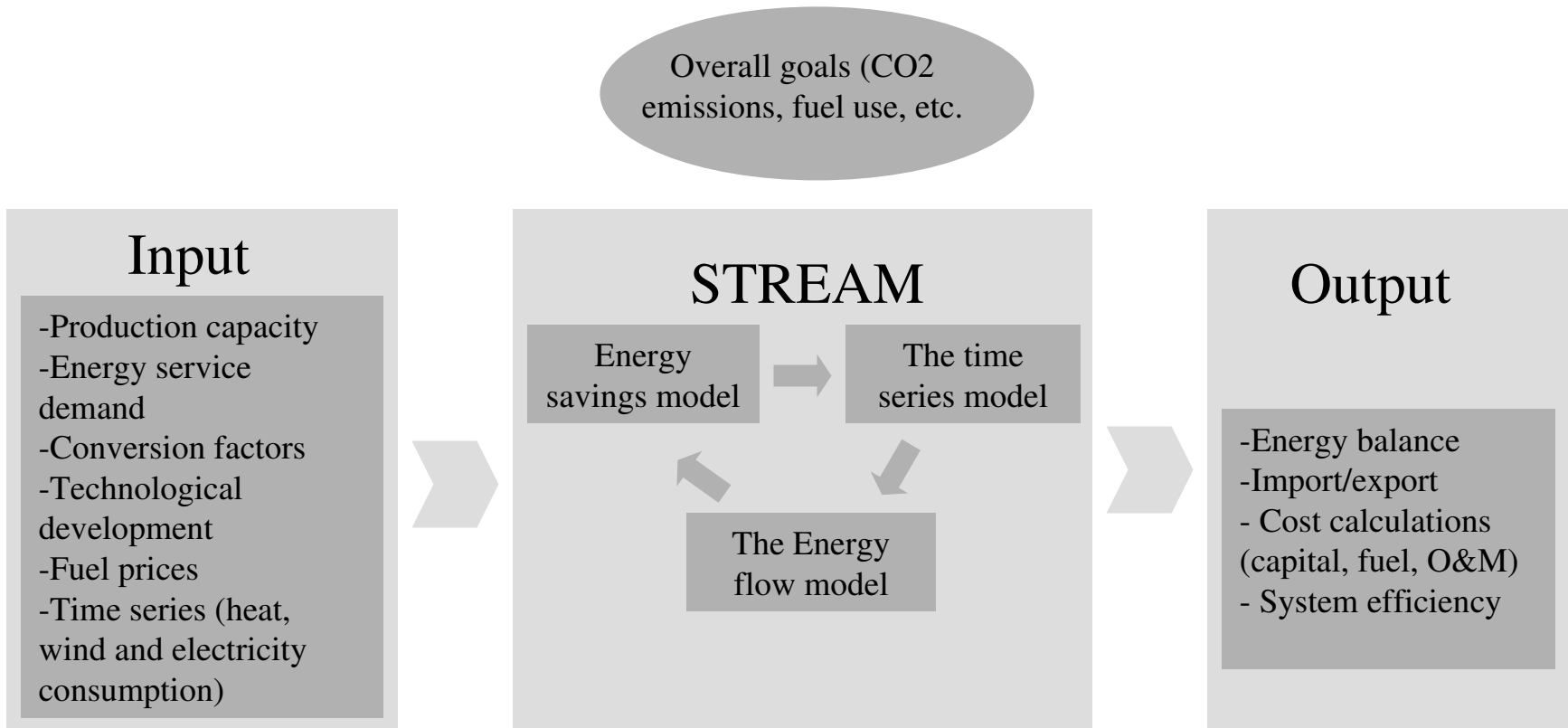

# The energy savings model



- Projection of demand for energy services
  - Calculated for households, service sector, industry and transport
  - In each area different end uses is identified as well as savings potentials and costs
  - Starting point for transport is amount of person kilometres

# The energy savings model



Regnearksmodel til fremskrivning af efterspørgslen efter endeligt energiforbrug baseret på baggrundstal fra Energistrategien og Energispareplanen.

Energisparescenario:		"Besparelse Scen1"		Scenarier: Reference		Kombiscenariet			
Anvendt rente ved investeringer:		6%		Reference scenario 2025		Kombiscenariet 2025			
Endeligt energiforbrug i sektorer	Forbrug 2003	Økonomisk vækst % p.a.	Intensitet faktor	Ekstra omk. ifht. basis mill. kr/år	Ekstra omk. ifht. reference mill. kr/år	Basis forbrug 2025	Reference scenario 2025	Kombiscenariet 2025	Kampagneomkostn 3 kr/GJ
	TJ			TJ	TJ	TJ	TJ	TJ	
Handel & Service	83.706	1,6	0,75	879	1.184	111.940	79.691	50.861	
Produktion	162.494	1,5	1,00	1.748	2.280	233.304	171.234	130.550	
Husholdninger, el - rumvarme	186.324	1,9	0,90	3.496	2.734	225.950	162.210	123.000	
<b>I alt</b>	<b>432.524</b>			<b>6.123</b>	<b>6.524</b>	<b>571.193</b>	<b>413.135</b>	<b>304.411</b>	
		Vækst transportarbejde		Årlig besparelse ifht. Basis :					
Transport, person	107.456	1,0%	1,00		2952	133.753	122.160	97.462	
Transport, gods	60.720	1,0%	1,00		591	75.579	64.308	53.372	
<b>I alt inkl. transport</b>	<b>600.700</b>				<b>10.067</b>	<b>780.525</b>	<b>599.603</b>	<b>455.245</b>	

Endeligt forbrug fordelt på brændsler (uden transport)	Forbrug 2003 TJ	Basis forbrug 2025 TJ	Reference scenario 2025 TJ			Kombiscenariet 2025 TJ		
El	115.647	157.367	28%	114.631	28%	76.017	25%	
Fjernvarme	108.270	128.958	23%	96.351	23%	82.183	27%	
Kul	9.199	12.682	2%	9.603	2%	4.524	1%	3%
Olie	91.755	118.758	21%	85.172	21%	25.991	9%	18%
Naturgas	74.572	94.372	17%	74.964	18%	67.524	22%	46%
Biomasse (Energiafgrøder)	0	0	0%	0	0%	0	0%	0%
Biomasse (halm, træaffald)	33.081	40.485	7%	32.413	8%	48.172	16%	33%
<b>I alt</b>	<b>432.524</b>	<b>552.624</b>	<b>100%</b>	<b>413.135</b>	<b>100%</b>	<b>304.411</b>	<b>100%</b>	<b>100%</b>

\* Alle investeringer er omregnet til annualiserede afdrag i 2003-kr. Svarende til lån, der afdrages med samme årlige betaling over investeringens levetid.

# The time series model



- Analyse correlations in the Danish electricity and CHP system on an hourly level.
- Indicates coherence between wind and combined heat and power production

# The time series model

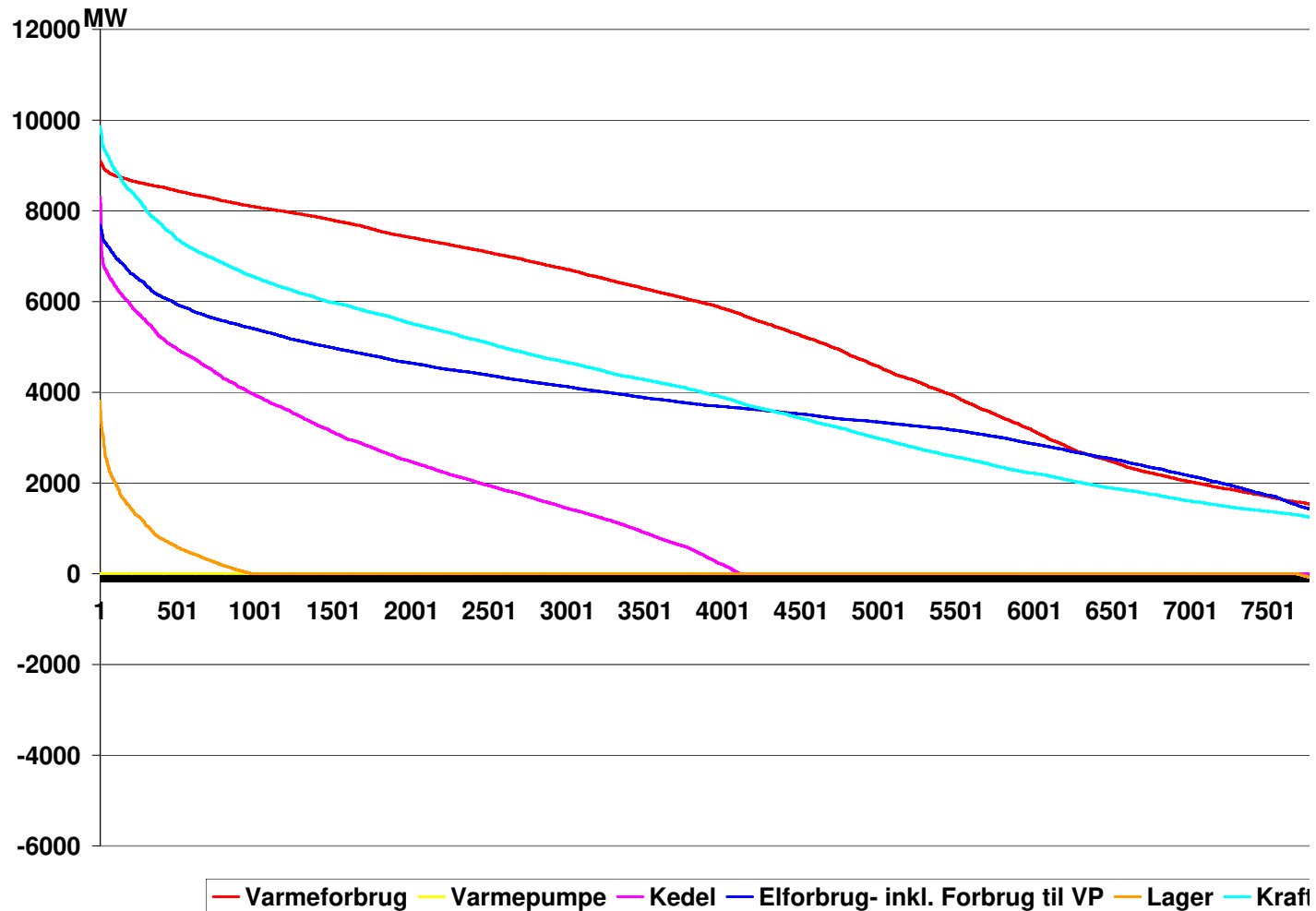

# The time series model



Elforbrugsvarighedskurve - fordelt på segmenter af 500 MW

(Husk: varighedskurven skal opdateres vha. makro)

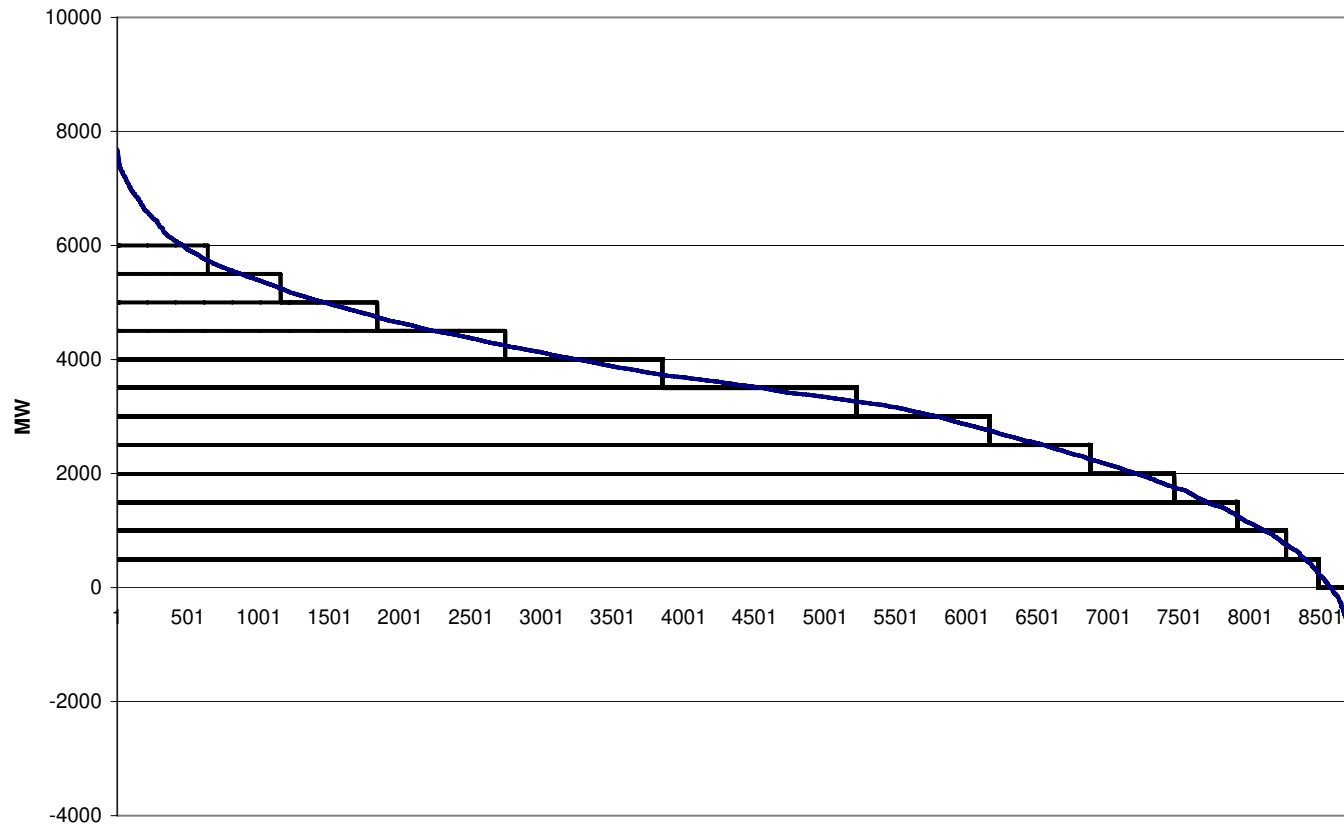

# The energy flow model



- Combine models with economics and technology data for a given year
- Produce tables and figures
- Economic costs is determined as the annual costs of running the system in a given year

# The energy flow model



Ambitiøse scenario					Brændsler				
Energiprodukter									
(PJ)	el	fjernvarme	varme/ brændsel	Total	el	fjernvarme	olie	kul	naturgas
el produktion	96,27			96,27			0,96	7,22	9,63
el, brændselsforbrug	144,60			144,60			1,77	12,67	15,05
virkningsgrad	67%			67%			54%	57%	64%
fjernvarme, produktion		104,83	0,04	93,05		#REFERENCE!	0,93	6,39	22,13
fjernvarme, brændselsforbrug		66,14		66,14			0,47	3,20	18,74
virkningsgrad / COP		159%		141%			200%	200%	118%
			<b>Produkt</b>						
brint, produktion			0,11	0,20	0,2				
ethanol, produktion		51%	10,12	19,70	1,3	5,2			
methanol, produktion			0,00	0,00	0,0				
biodiesel, produktion			10,15	12,10	1,3	0,2			
varmeforbrug			65,42		7,18	74,51	11,80	1,83	32,36
varmeforbrug, brændsel			73,75	158,54	7,18	77,61	13,11	2,28	34,06
virkningsgrad			89%		100%	96%	90%	80%	95%
nettab	6,01	20,38							
egetforbrug	0,00								
Tvungen el-eksport	(0,55)								
ikke energiformål			0,00						
	El	Fjernvarme	Summen af brændsler	Total	Brændselsforbrug inkl. konverteringstab				
Handel og service	20,13	23,90	6,83	50,86	20,13	23,90	0,68	0,00	3,41
Produktionserhverv	36,02	10,87	83,67	130,55	36,02	10,87	19,56	4,35	38,03
Husholdning	19,86	47,42	55,72	123,00	19,86	47,42	5,75	0,18	26,08
Transport	7,67		146,53	162,45	10,51	5,41	121,35		1,45
Forbrug excl. transport	76,02	82,18	146,21	304,41			25,99	4,52	67,52
Forbrug	83,68	82,18	292,74	466,86			147,34	4,52	68,97
<b>Total bruttoenergiforbrug</b>	<b>144,60</b>	<b>66,14</b>	<b>292,74</b>	<b>503,48</b>			<b>149,58</b>	<b>20,38</b>	<b>102,76</b>



# Modelling challenges



- Economic costs from investments and measures handled in a very simple manner
- No economic or advanced optimization of the energy flow and exchange with neighbouring countries.



# Origin of data

- Data availability often decisive for modelling
  - Especially in the Energy savings model
- Access to many parties through the scenario process and the active involvement from the politicians

# Agenda



1. The scenario process
2. The results
3. The modelling tool
  - Energy savings model
  - The time series model
  - The energy flow model

4. Perspectives



# Perspectives

- Consolidation of model
- Public access to modelling tool
- Modelling tool creates common references and understanding of challenges in scenario discussions
  - Also outside Denmark

# Vanadium redox-flow batteries

## – Installation at Risø for characterisation measurements

### **Henrik Bindner**

Wind Energy Systems

Wind Energy Department

Risø, DTU

Risø International Energy Conference May 2007

Acknowledgement:

The work presented is supported by Energinet.dk through the PSO-project "karakterisering af vanadium batteri"

## Presentation outline

- Power system with a high penetration of wind
- Applications of energy storage and energy storage technologies
- Vanadium batteries
- Vanadium battery as part of SYSLAB
- Current Status and test results

## Power Systems with high penetration of wind

- Production and consumption has to match at any instant
- Issues with wind
  - Fluctuations
  - Variations
  - Predictability
- The rest of the system has to compensate for the fluctuations on the short time scale (sec-min) and variations and prediction errors on a longer time scale (hours-days)
- Flexibility of the rest of the system is crucial for achieving high penetration
- More and more functions are provided via a market

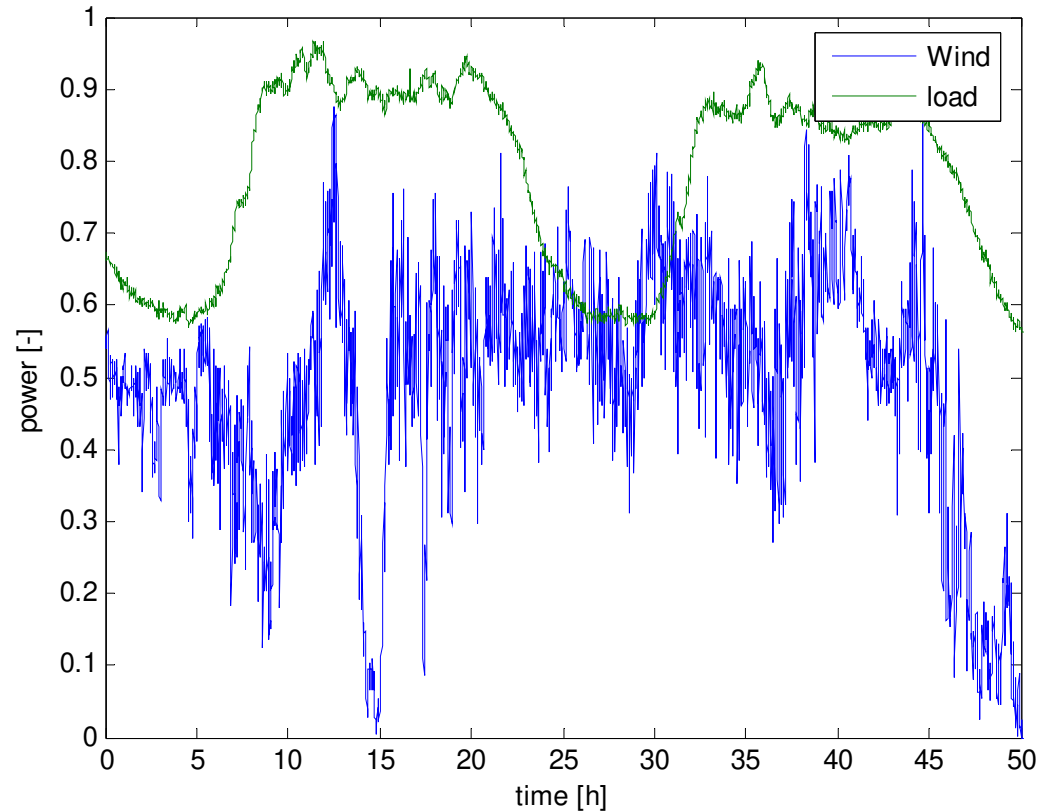

- Flexibility can be provided by several means
  - Production
  - Flexible/intelligent consumption
  - Energy storage

## Power plant functions from wind farms

- Wind turbines are installed in larger and larger wind farms
- The spatial smoothing is reduced resulting in larger fluctuations
- but coordinated control of all the wind turbines is improved
- During recent years there has been an effort to develop functions similar to other power plants to provide frequency and voltage control support
- Due to the stochastic nature of wind it is limited what can be obtained without support technologies

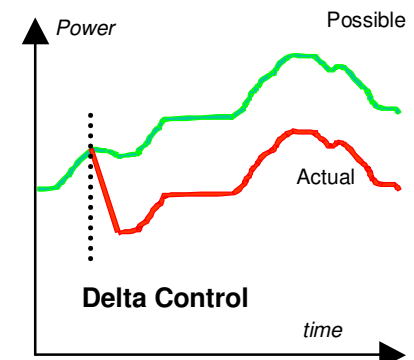
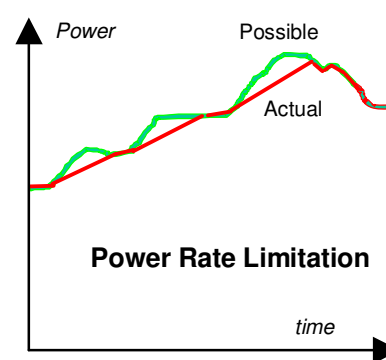
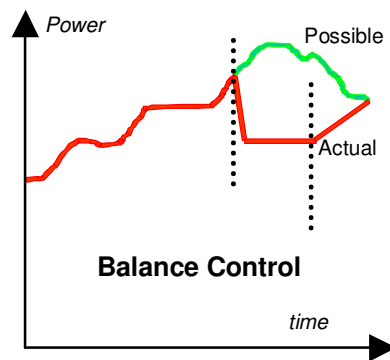
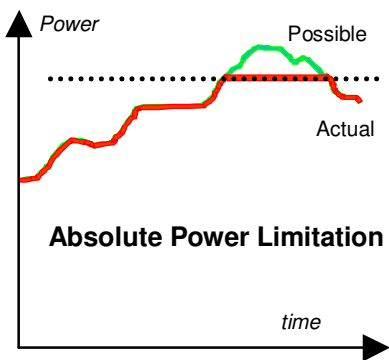



## Energy storage functions and issues

- Batteries can have many functions in the power system
- Several of the storage technologies can provide several functions simultaneously
- Potential functions include:
  - Very short term power quality improvement
  - Uninterruptible power supplies
  - Reduction of short term fluctuations in renewable energy production
  - Reduction of spinning reserve
  - Reduction of standing reserve
  - Daily smoothing
  - Seasonal storage
  - Energy arbitrage
- Issues with application of batteries:
  - Costs
    - Uncertainty of cost
      - Lifetime
      - O&M cost
  - Efficiency
  - Self-discharge
  - Operational capabilities
  - Reliability
  - Safety and environmental issues

# Energy storage technology overview

Technology	Power/Energy Range	Applications	State of development
Supercapacitors, superconducting magnetic energy storage	High power Low energy	UPS, power quality	Pre-mature
Flywheels	High Power Low Energy	Power quality	Mature
Batteries: lead acid, lithium, sodium-sulphur, nickel	Medium power Medium Energy	UPS, RE fluctuation reductions	Pre-mature – mature
Redox-flow batteries: Vanadium, Br-S, Zn-Br	Medium power High Energy	RE fluctuation reduction, spinning/standing reserve	Pre-mature
Pumped hydro	High Power Very High Energy	Spinning/standing reserve, energy arbitrage	Mature
Compressed air	High Power Very High energy	Spinning/standing reserve, energy arbitrage	Mature
Hydrogen	Medium Power High Energy	RE fluctuation reduction, spinning/standing reserve	Prototype
Thermal	-	RE fluctuation reduction, spinning/standing reserve	Mature
Demand response	-	RE fluctuation reduction, spinning/standing reserve	Pre-mature

# Vanadium redox-flow battery technology

- Flow/membrane based battery
- Electrolyte is vanadium dissolved in sulphuric acid

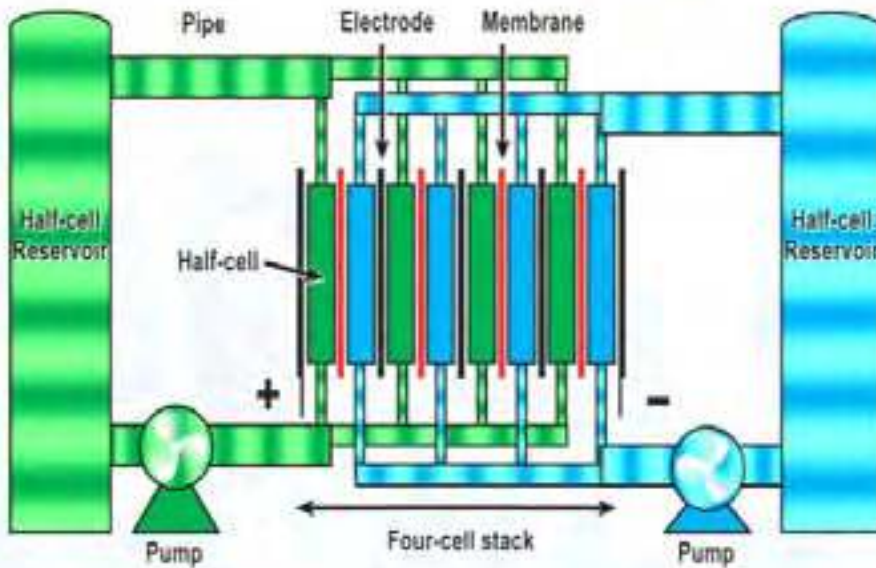

- Only change in valence of vanadium



Charge



Discharge



- Electrodes do not participate in the electro-chemical process
- Same electrolyte on both sides
  - No cross-contamination
  - Very long lifetime
- Independent sizing of power and energy capacity
- Low maintenance
- Very good cycling capability – more than 10000 cycles
- Good efficiency ~75%
- Low self-discharge
- Fast response

# Vanadium flow battery

- Current costs:
  - 250kW/2MWh:\$1.000.000
- Potential for lower cost if mass-produced
- Energy density:  
~25Wh/kg
- Risø unit:
  - 15kW/120kWh
  - 4 quadrant power electronics
  - Island and grid connected mode of operation

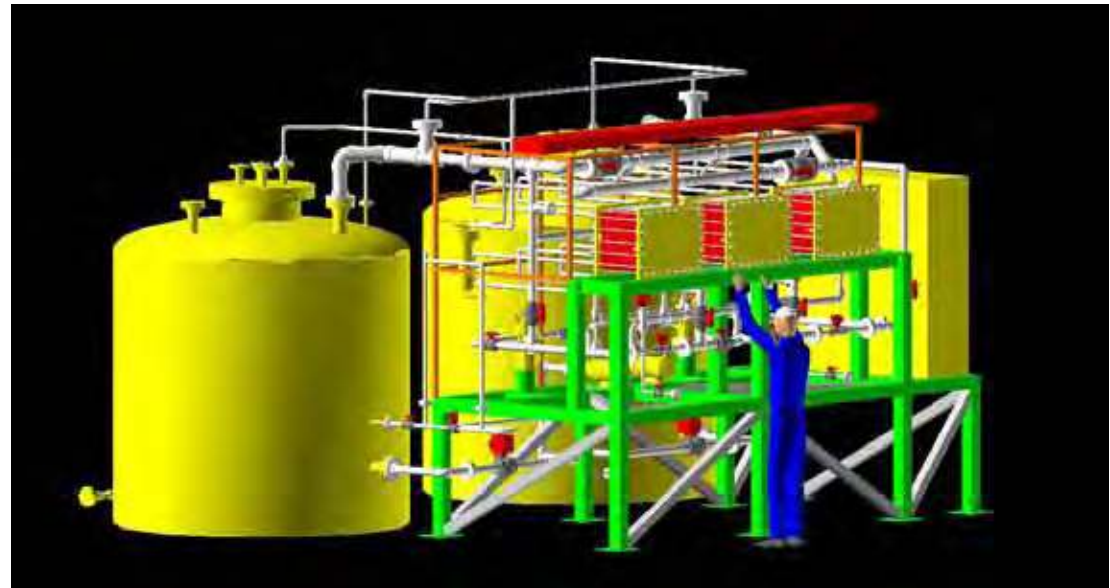
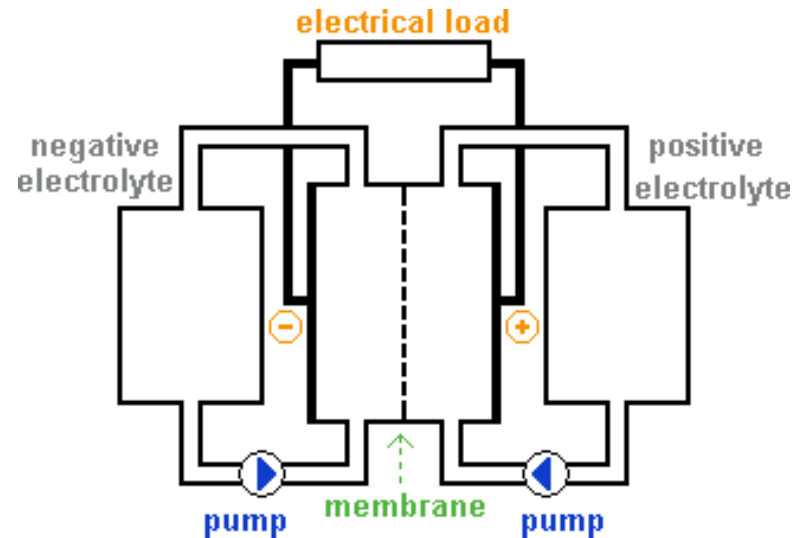

## Component testing – Characterisation of vanadium batteries

- PSO-project – supported by Energinet.dk
- Hands-on experience
- Efficiency @ different operating conditions
- Response time etc.
- Limits for operating range
- Cycling ability
- Grid interface

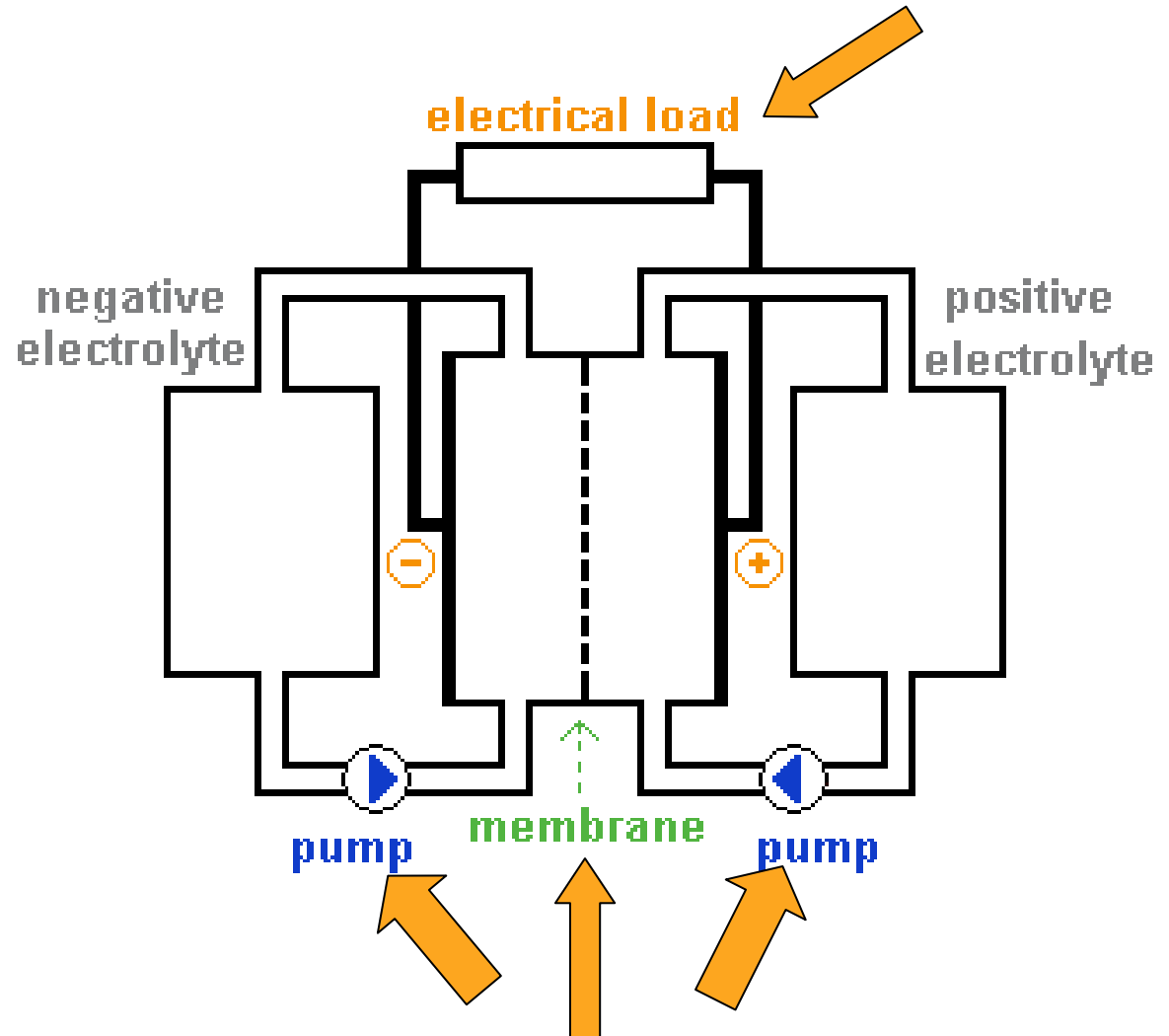

# SYSLAB – Distributed Energy System Laboratory



## High penetration wind power systems

- Intelligence/Communication
  - Embedded, distributed control
  - Self-organising distributed control
- Flexibility
  - FlexHouse, Demand response
  - Vanadium battery
  - Hybrid/Electric car



## SYSLAB – Development perspectives

- Investigate technical possibilities
  - Embedded intelligence
  - Distributed control
  - Integration of energy carriers
  - Multiple RE sources
- Possible extensions
  - Hydrogen/Fuel cells
  - Biomass
  - Risø district heating/houses
- Integrates several areas of research
- Upscaling to nationwide system
  - Simulations (IPSYS)
- Facility used in PhD and MSc projects

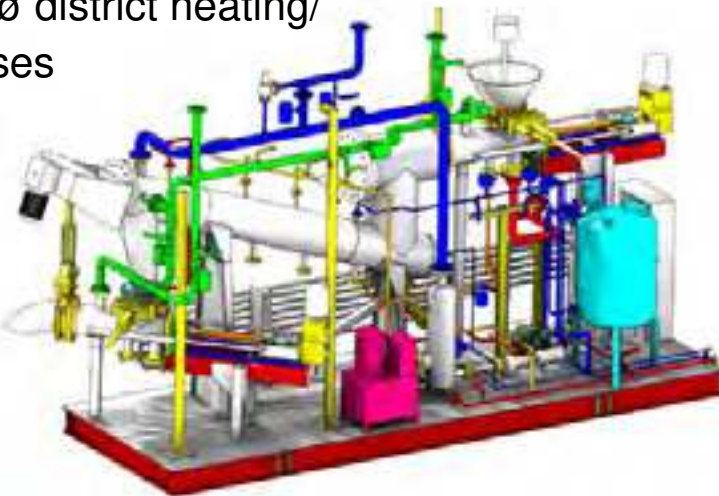

1-5 kW Topsoe FC CHP Test System

# Electrical layout of SYSLAB

- Flexible grid configuration
- Autonomous grid
- Units can be tested in under various grid conditions
- Suitable for component and system tests
- Very flexible control

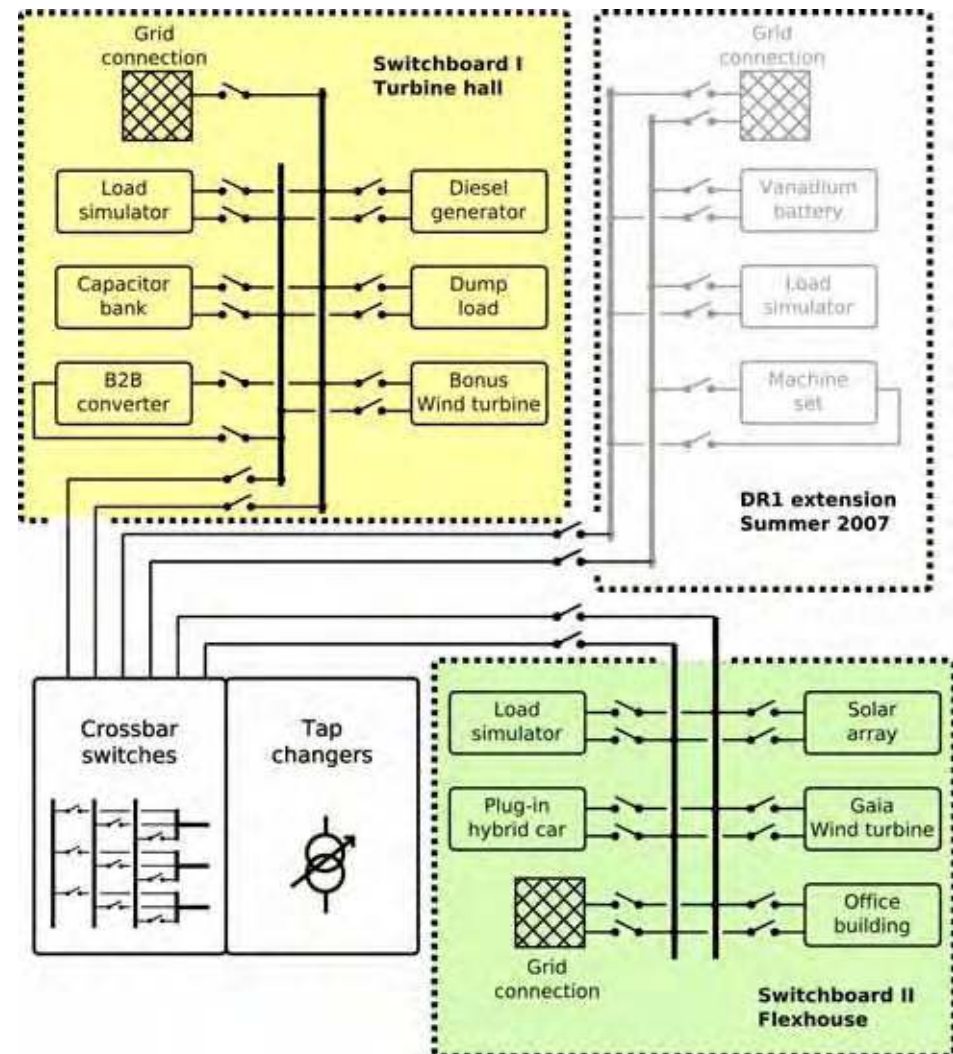



## PowerFlexhouse

- Intelligent control
- Demand response
- Many individually controllable loads
  - Heater
  - Airconditioners
  - Water heater, coffee machine
- Many sensors
- System-house and house-user interaction and communication
- Plug-in/vehicle2grid hybrid car: Toyota Prius with extended battery and bi-directional converter

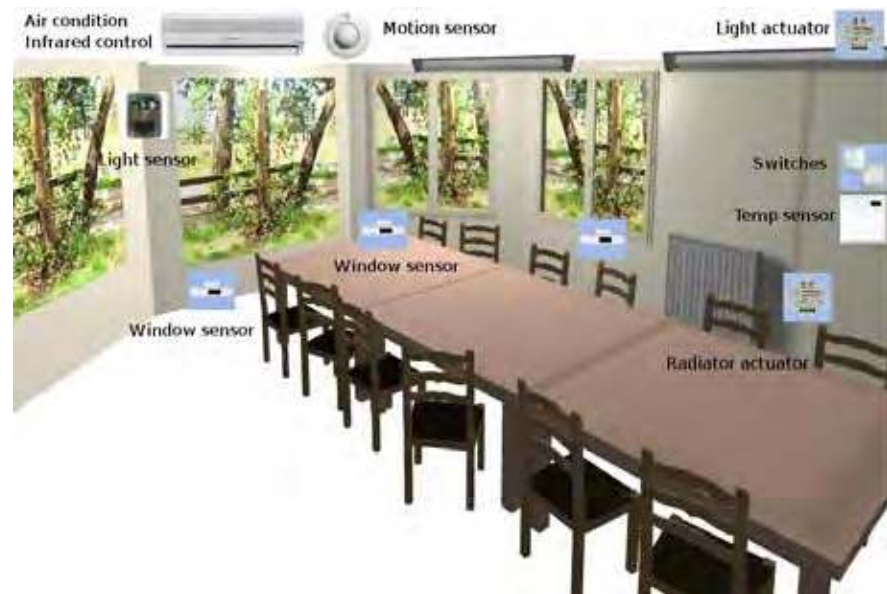

## Vanadium redox-flow batteries – initial results

- Unit will be installed in August 2007
- Unit is being factory testet



- Foot-print is 7mx7m
- Tanks are 8m<sup>3</sup> each



## Factory test of system

- 3\*kW cells stacks
- 15kW/20kVA power electronics





# Factory tests II

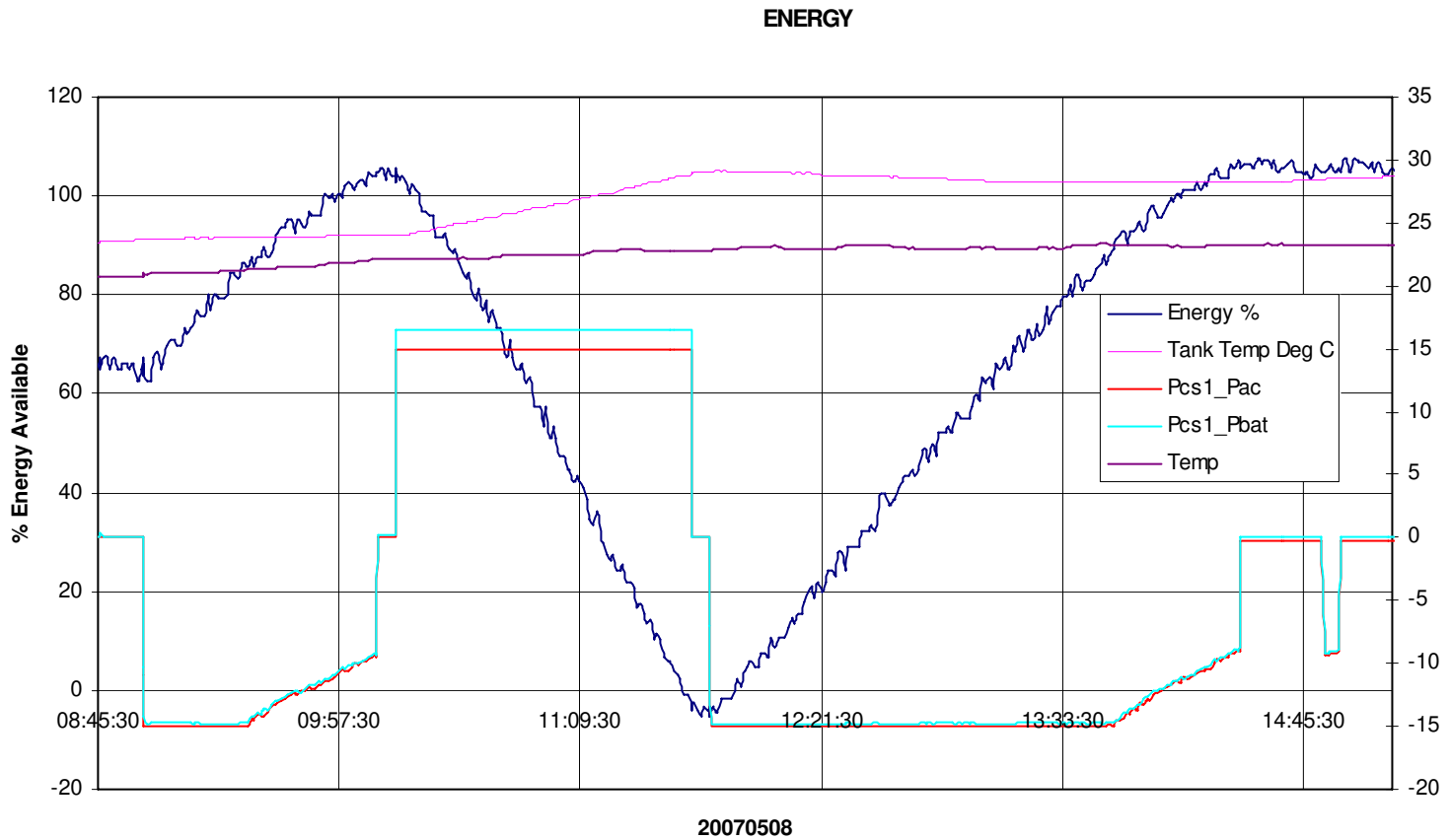

## Factory test III

- Cycling test

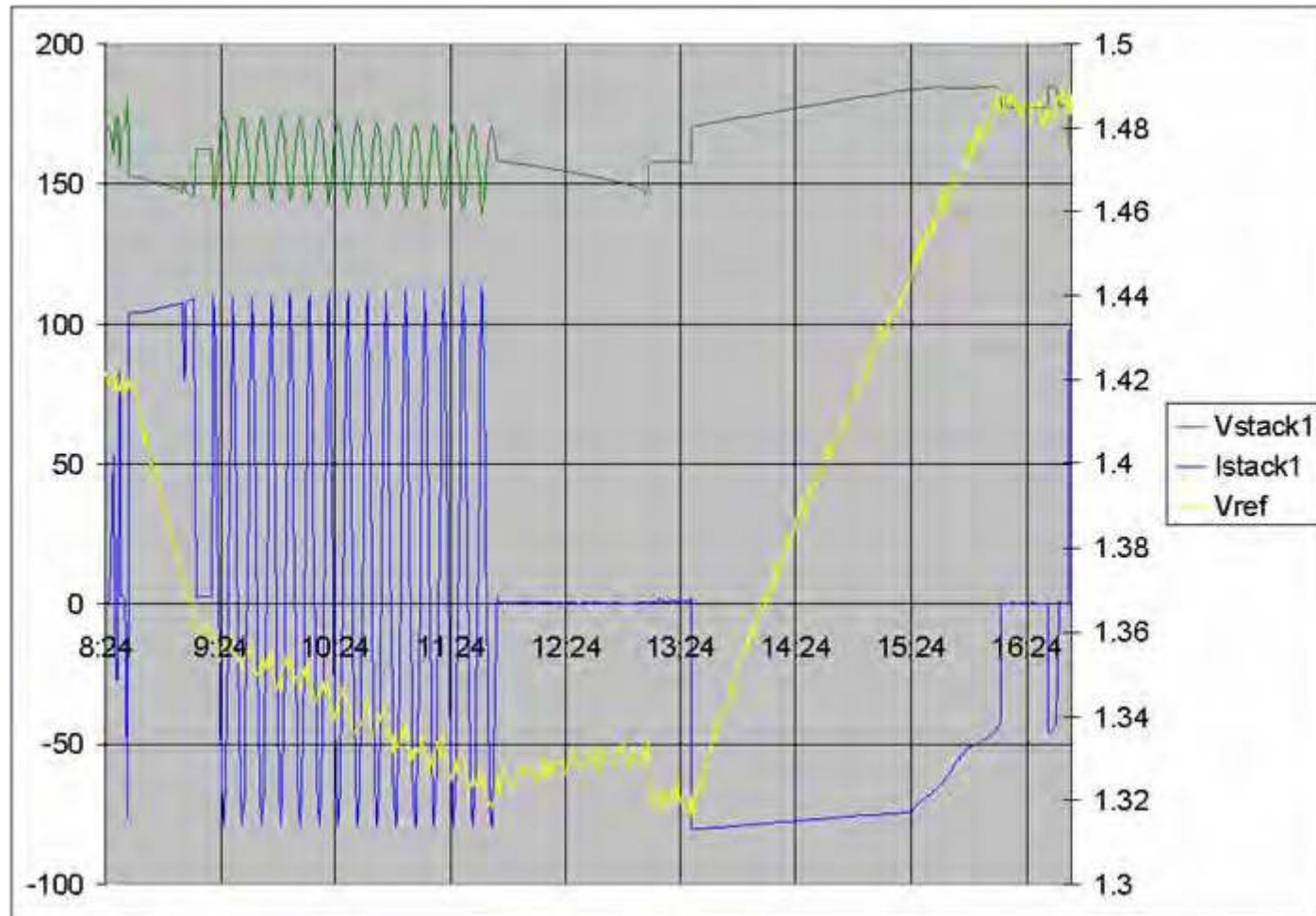

## Factory test IV

- Single charge-discharge cycle

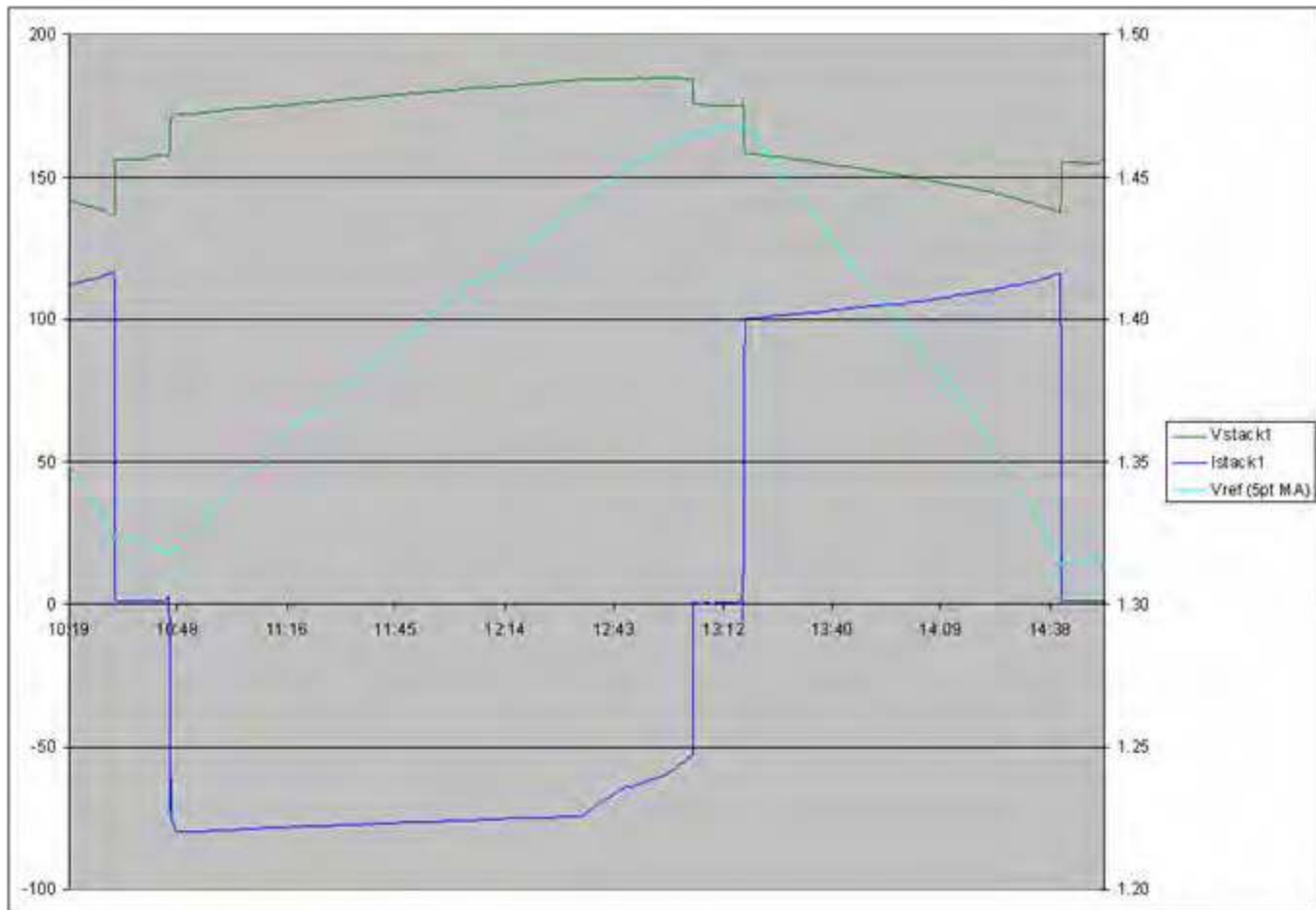

## Demonstration of the SYSLAB facility

- Everyone is welcome at SYSLAB after the conference
- The SYSLAB will be demonstrated and there will be time for discussions
- See you at the center of the **RED** circle (Møllehallen)



# **Centralised and decentralised control – a power system point of view**

Oliver Gehrke (Risø/DTU)  
Stephanie Ropenus (Risø/DTU)  
Philippe Venne (UQAR)



## Outline

- (1) Requirements and challenges for current power systems
- (2) Design parameters for power system evolution
- (3) Decentralised control
- (4) Activities at Risø

## Demands for future power systems

- Integration of distributed generation
- Integration of intermittent energy sources
- Markets for power and ancillary services
- Open, equal and barrier-free access for third-party service providers
- Security of supply
- Power quality
- Energy efficiency

## Limitations and challenges in current systems

- Growing complexity, bad scalability
- Limited access to power markets
- Lack of data and automation in large parts of the grid
- Lack of flexibility: Power system structure is considered static in the short and medium term
- DG *needs* to provide ancillary services, because their peak contribution grows faster than their average contribution
- Large untapped potential for demand response (households, refrigerated warehouses, greenhouses etc.)
- Lack of transmission capacity

## Design parameters

Not a simple evolution in one area of technology.

Many aspects and design parameters and no general agreement on the target.

- Role of small DER and households
- Types of markets for power and ancillary services
- Market access rules and regulation
- Communication
- Topology of distribution grids
- Role of storage technologies
- Role and providers of ancillary services
- Role of the system operator and its control center

Big differences in current implementations, under technological, economical and political aspects.

## Use of communication technology

*Increasing activeness of small DER*



Dedicated (private) communication links between control center and larger units

One-way broadcasts to smaller units

Two-way communication with DER at the household level, using public infrastructure

Communication protocols beyond SCADA (policies, negotiation etc.)

## Small DER interaction

*Increasing participation*



Meter read once a year

Real-time metering and price signals  
(user-in-the-loop)

Automated demand response

Direct participation in market mechanisms  
(power and ancillary services)

## Market access

*Easier access*



High thresholds (capacity requirements, trading fees)

Market aggregators allowed

Open access to markets or sub-markets

## System control and operation

*Increasingly decentralised*



Control Center

Aggregation (Virtual Power Plants)

Delegation (Services provided by grid)

Self-organisation



## Interrelations

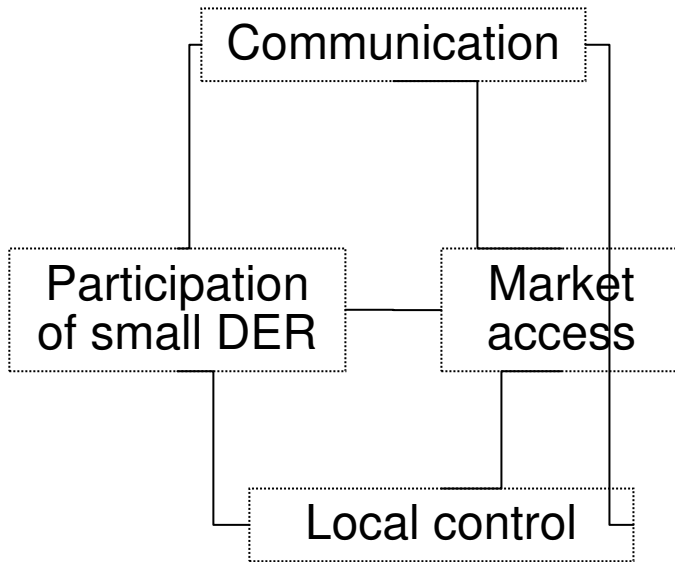

Design parameters are mutually dependent, but not always strongly linked.

Example: Market access for small DER requires some form of communication, but not all types of communication link make sense economically.

Many possible scenarios, picking a particular one is speculative.

The way of operating and controlling the power system is a central issue. It is not clear what is technically possible.

## Decentralised operation and control

- Reducing complexity by solving local issues locally, with local data
- Better scalability, making future DER technologies less disruptive
- More flexibility when responding to changes in system structure
- Eliminating single points of failure
- Need for widely available protocols and interfaces promotes accessibility

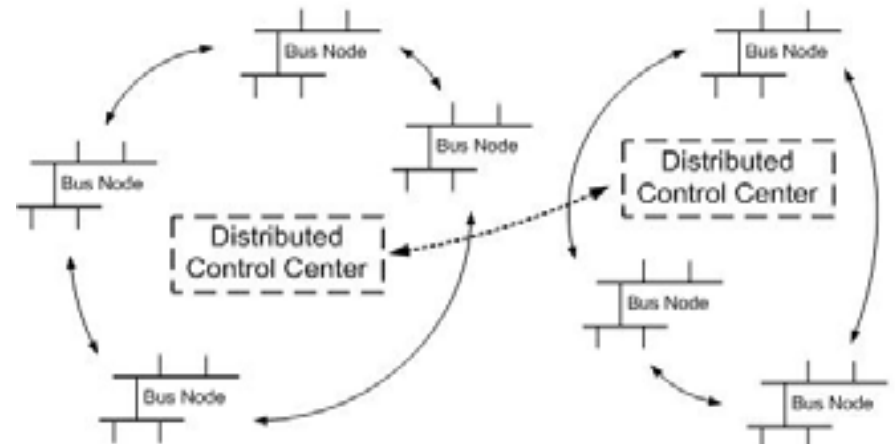
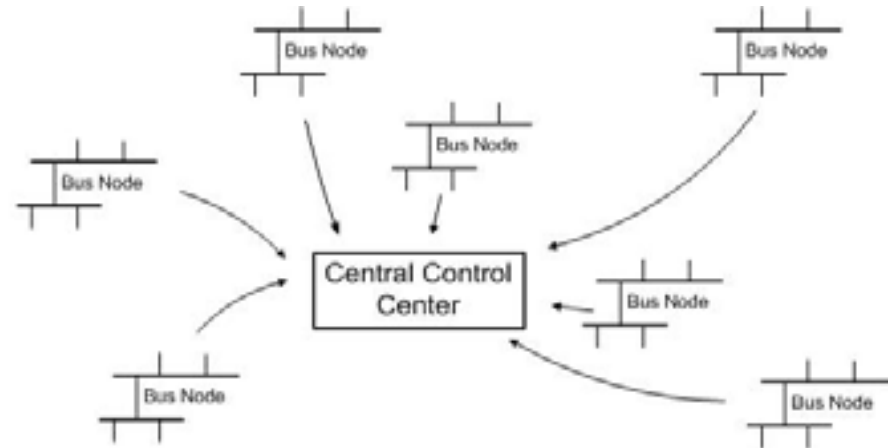

## Vision for a future power system (2025+)

- Grid is self-aware (knows its topology, capabilities, limits and state)
- Role shift: System operator-> System facilitator
- “Human-out-of-the-loop”: Supervisors set policies, rather than execute them.
- Flexible, negotiated control hierarchies
- Boundaries between transmission and distribution system become blurred
- Wide-scale use of automated demand response at the household level
- Use of public communication networks (Internet) for small-size DER
- Open – and largely automated - access to markets for power and ancillary services
- New services: Self-islanding, dynamic protection management

## Generic control architecture

Generic architecture for a decentralised power system

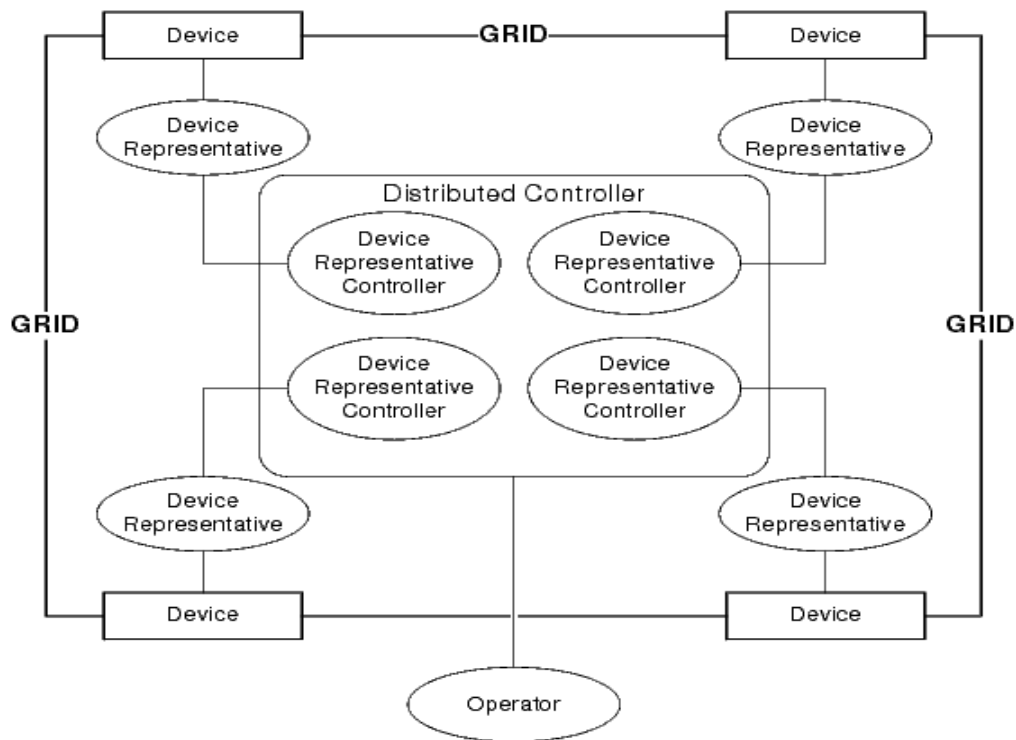

- Device: Grid-connected energy resource
- Device representative: Logical unit providing access to a device
- Device representative controller: Supervises one or more devices
- Distributed controller: Composed of individual controllers

## “Playground” implementation: SYSLAB

Not feasible to test in a real power system (not at this stage) and no tools available for the combined simulation of

- power system dynamics
- stochastic communication systems
- real-time decentralised decision making

Possible approaches:

- Use a small experimental power system (accepting that scaling issues are postponed)
- Use a real-time grid simulator with real-world controllers (accepting that interfacing issues are postponed)

Advantages of an experimental system:

- Most realistic control system studies
- Results have more convincing power
- Advanced environment for component testing

## SYSLAB: Concept

- One intelligent node per power system component
- Local data acquisition and storage
- Development of self-organising middleware for “plug-and-play” operation
- Supervisory control shared between nodes

Purpose: Testing of communication protocols, control algorithms, energy technologies and components, human-machine interaction

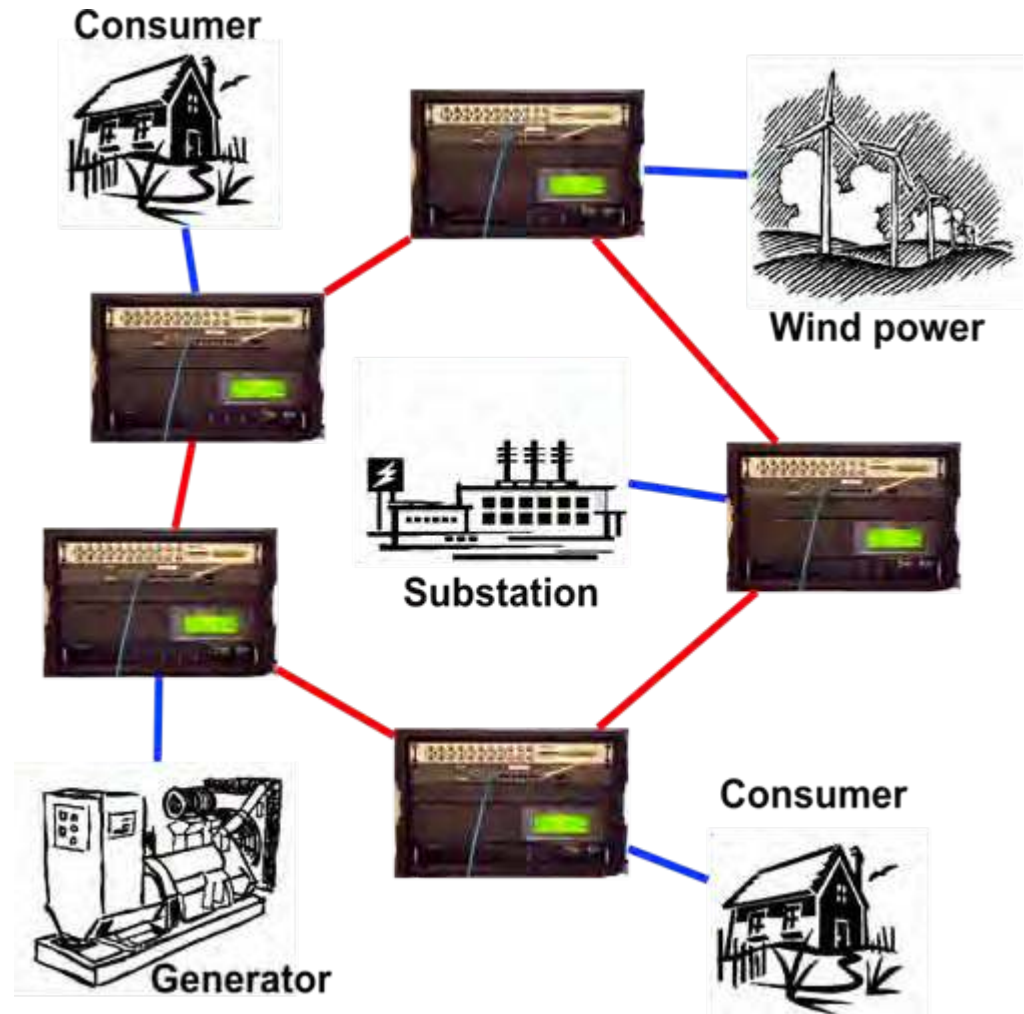

# **Assessing the Role of Energy in Development and Climate Policies in Large Developing Countries**

Amit Garg and Kirsten Halsnæs

**Risø International Energy Conference 2007**

24 May 2007

## Research Enquiry

- How to align sustainable development, energy and climate change policies at national level (for Brazil, China, India and South Africa)?
- What are sustainable development indicators and their future projections that capture the above alignments?
- What are the CO<sub>2</sub> and local pollutant emissions implications of development under a reference scenario for these countries?
- Can alternative development pathways align energy and climate change policy perspectives, and how?



# Development, Energy and Climate Project

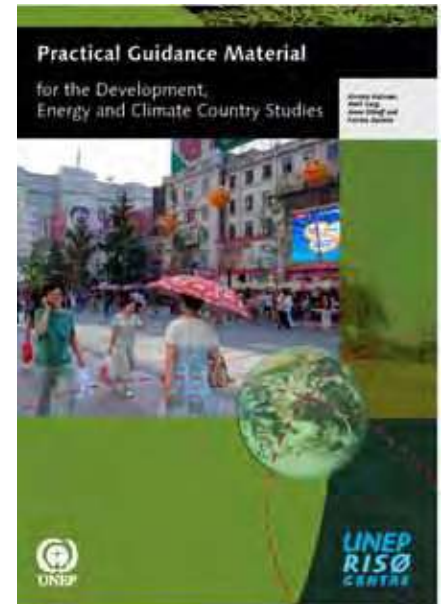



**IIMA**  
India

**ERC**  
South Africa

**ENDA-TM**  
Senegal

**BCAS**  
Bangladesh

**KEI**  
S. Korea

**ERI**  
China

**COPPE**  
Brazil

**Stanford Univ.**  
USA

**IISD**  
Canada

**UNEP Risø Centre**  
Denmark

**MNP/RIVM and PRI**, The Netherlands  
**IIED**, UK  
**PIK**, Germany  
**CIREN**, France

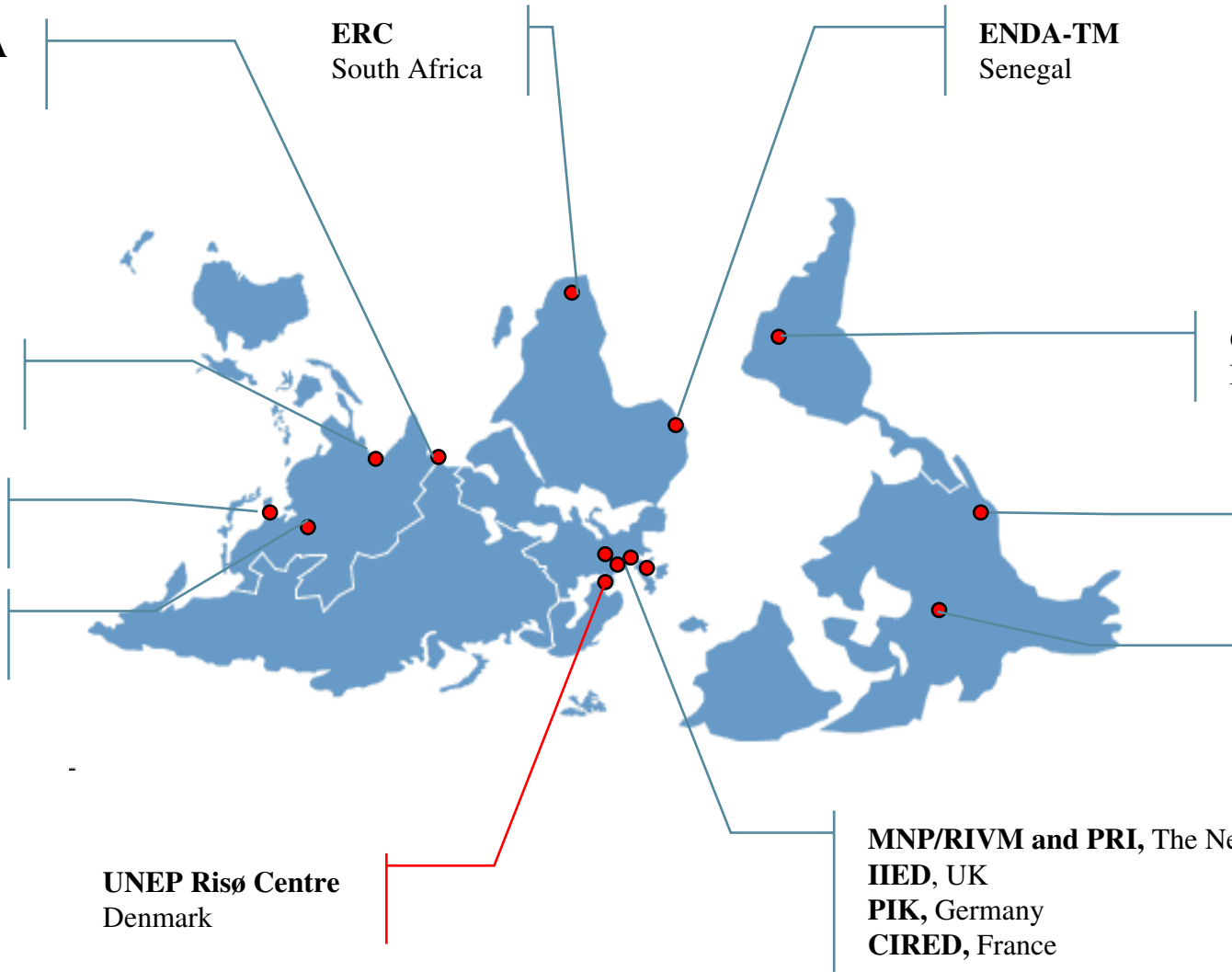

## Methodology

- Used integrated energy modelling framework
- Each country uses comparable energy-environment models
- Consistent reference scenario assumptions in line with global climate change scenario efforts
- Consistent assumptions on oil and gas prices, UN population projections
- National case studies conducted and up scaled to integrate with country models

## Why Use an Integrated Energy Framework for SD Assessment?

- **Human activities and most sustainability issues are closely linked to energy use**
  - Critical component in factor productivity (capital, labor, land), can constrain well being, missing energy imposes time and labor burden on households
  - Most important sustainability issues (poverty alleviation, health, education, economic development) as well as climate change issues directly relate to production and use of energy
  - Even some of the other important sustainability issues (freshwater, landuse, atmospheric integrity, agriculture) are directly/indirectly related to production and use of energy
  
- **World (humans, systems and environment) can be easily visualized as a *flow of and linked through energy***

## Why Use an Integrated Energy Framework? (contd.)

### ➤ **Offers consistent, comparable and transparent framework for future projections**

- Relationships between sustainability dimensions are considered consistently
- Can project and compare across alternative development pathways
- Can compare across different countries (if due care is taken)
- Can compare SD and CC impacts of competing technologies

### ➤ **Possible to estimate future energy flows and most of the proposed indicators with commonly used energy models**

- Economic models miss out on environmental issues such as climate change
- Environmental models miss out on macro-economic depth and are very sector/region specific

## Modeling SD, Energy and CC Linkages

Millennium development goals and global targets	India's national development targets	Energy sector implications	Implications for energy modeling
<p><b><u>Goal 1: Eradicate extreme poverty and hunger</u></b>  <i>Target 1:</i> Halve, between 1990 and 2015, the proportion of people whose income is less than \$1 a day  <i>Target 2:</i> Halve, between 1990 and 2015, the proportion of people who suffer from hunger</p>	<ul style="list-style-type: none"> <li>● Double the per capita income during 2002-2012</li> <li>● Reduction of poverty ratio by 5 percentage points during 2002-2007 and by 15 percentage points during 2002-2012</li> <li>● Reduce decadal population growth rate to 16.2% between 2001–2011 (from 21.3% during 1991–2001)</li> </ul>	<ul style="list-style-type: none"> <li>● Energy for increased production and consumption</li> <li>● Energy for local enterprises and machinery</li> <li>● Energy and electricity to facilitate income generation</li> <li>● Energy for providing family planning and health services</li> </ul>	<ul style="list-style-type: none"> <li>● GDP and population projections</li> <li>● Sectoral demand projections consistent with the above</li> <li>● Reflect/capture inputs needed for increased health services etc in sectoral demand projections</li> <li>● Energy needed for the above using sectoral/ national models</li> </ul>

## Proposed Sustainable Development Indicators (SDI)

**Using energy framework for SDI requires an approach where the energy analysis starts with development and human needs rather than structured around energy system logics**

### ➤ **Economic indicators**

- Efficiency of production indicators
- Efficiency of energy use indicators
- Energy investment indicators

### ➤ **Environmental indicators**

- GHG and local pollutant emissions (per unit of output and per capita)
- Share of solid fuels in residential sector (households)

### ➤ **Social indicators**

- Energy affordability indicators
- Per capita consumption
- Share of clean energy in residential sector (households)

# Integrated Energy Modeling and SDI

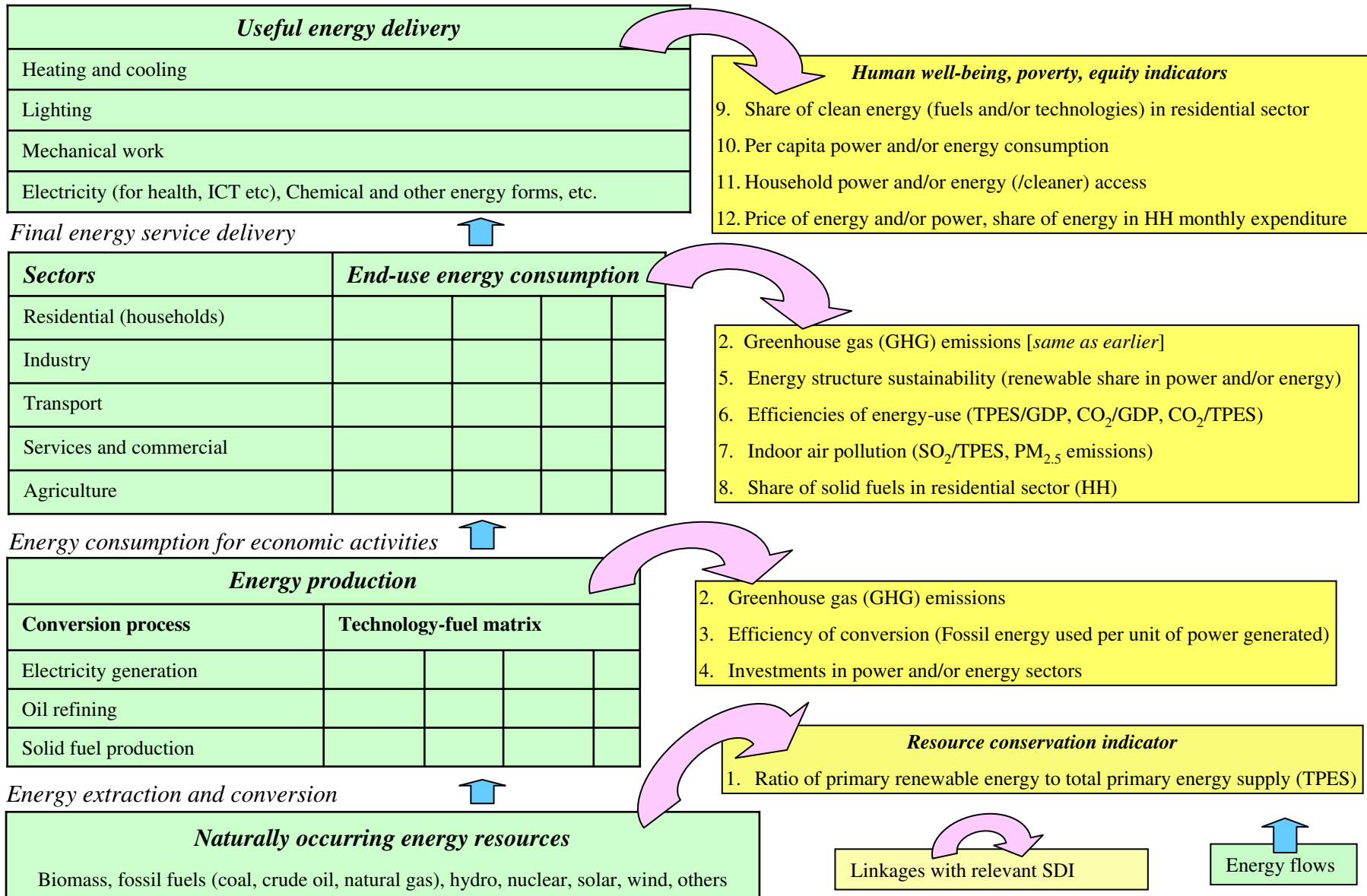



# Some Cross-country Results

## Energy Policies Linked with SD and CC

<i>China</i>	
2004	Energy Medium-Long term Development programme (2004-2020), such as energy security, energy efficiency, and clean-coal.
2004	60 GW renewable power capacity by 2010 (10% of total power generating capacity) and 121 GW by 2020 (12% of total capacity)
2005	Medium-Long term Energy Conservation programme, annual energy conservation rate of 2.2% till 2020 covering various sectors.
Current	Strong economic growth, and declining population growth
Current	More efficient coal-based power generation from existing and new plants
Current	Strong thrust on energy efficiency improvement in all sectors (e.g. 20% energy intensity reduction during 2005-2010, efficiency of coal-fired power plants to increase to 40% by 2030, new building to reach 75% increase standards in 2030 etc.)
UC	Nuclear power capacity of 40 GW by 2020

## Energy Policies Linked with SD and CC

<i>India</i>	
Current	More efficient coal-based power generation from existing and new plants
2001	reduce power transmission and distribution losses
2002	10% of new power generation capacity by renewables by 2012
2002- Current	Doubling per capita income during 2002-2012, and to reduce decadal population growth rate to 16.2% between 2001-2011 (from 21.3% during 1991-2001)
2002	Auto fuel policy: Emission norms for new vehicles - Euro-3 equivalent norms from 2010 for the entire country, but for 11 large cities Euro-3 equivalent from 2005 and Euro-4 equivalent from 2010
2005	Ethanol blend in gasoline (up to 5-10% in phases), ongoing discussions for expansion
2005	100% household electrification in rural areas by 2010 covering 75 million rural households, and modernizing rural electricity infrastructure
2006	Minimum employment guarantee scheme for rural areas (100 days' employment per household per year) in 200 districts (extended to 350 districts now)
UC	Nuclear power capacity of 20 GW by 2020

# Efficiencies of Energy Use

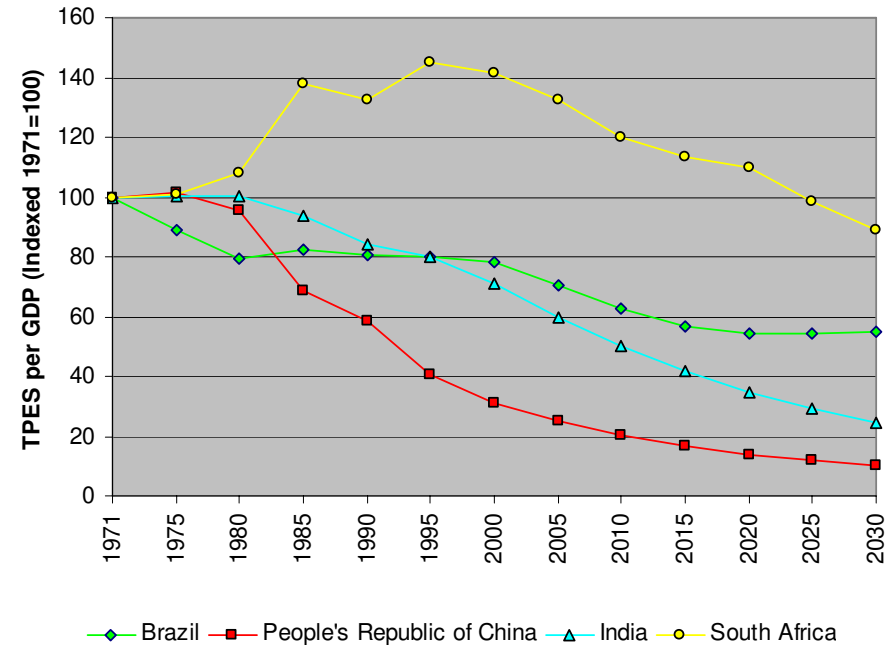
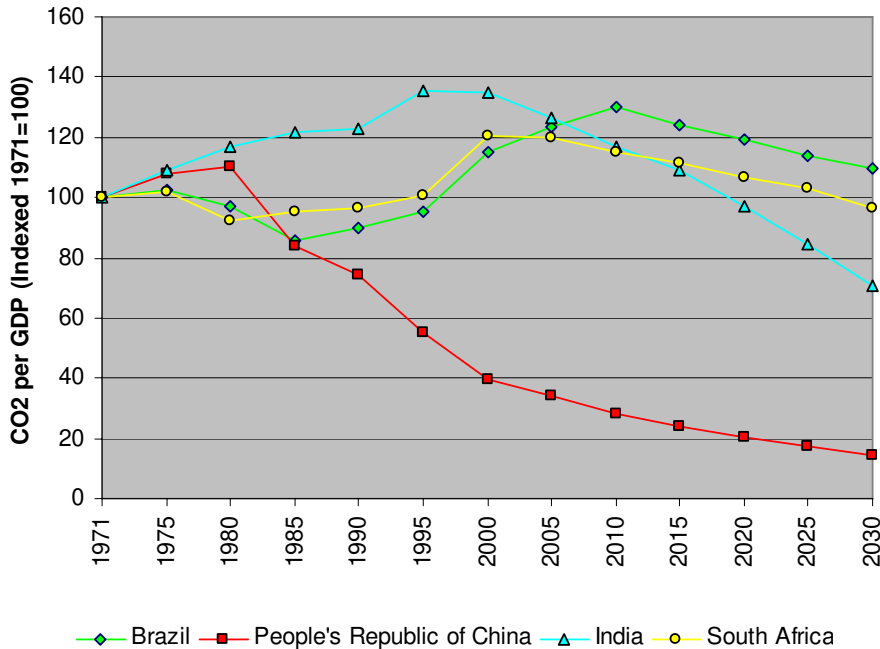

- GDP becomes less energy and less CO<sub>2</sub> intensive under all scenarios
- Decoupling rates, timings and extent are however different for different countries
- Sectoral variations exist in each country

## Decoupling of Energy and CO<sub>2</sub> Emissions

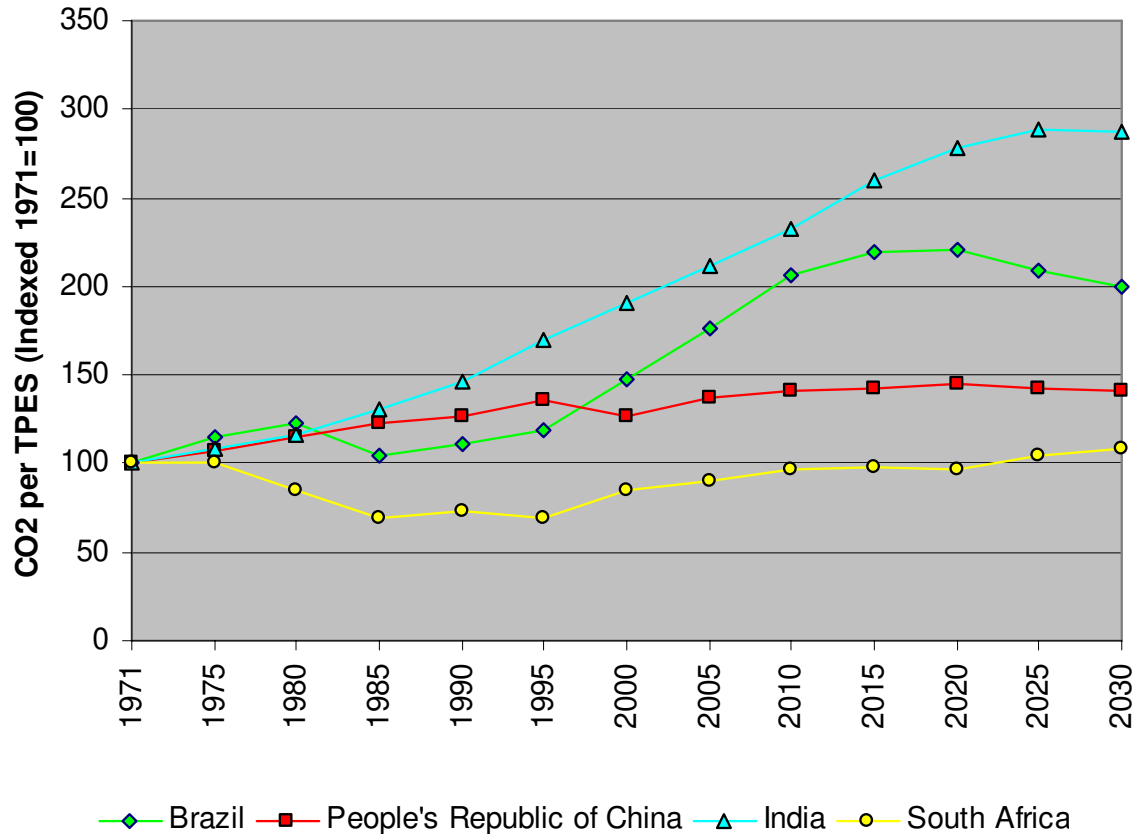

- Energy and CO<sub>2</sub> emissions do not decouple much under reference scenario
- Reasons are different for each country

# CO<sub>2</sub> and Local Pollutant Emission Projections

- Large developing countries are projected to add considerable fossil fuel based capacities during 2007-2030
- CO<sub>2</sub> emissions are projected to grow as a result

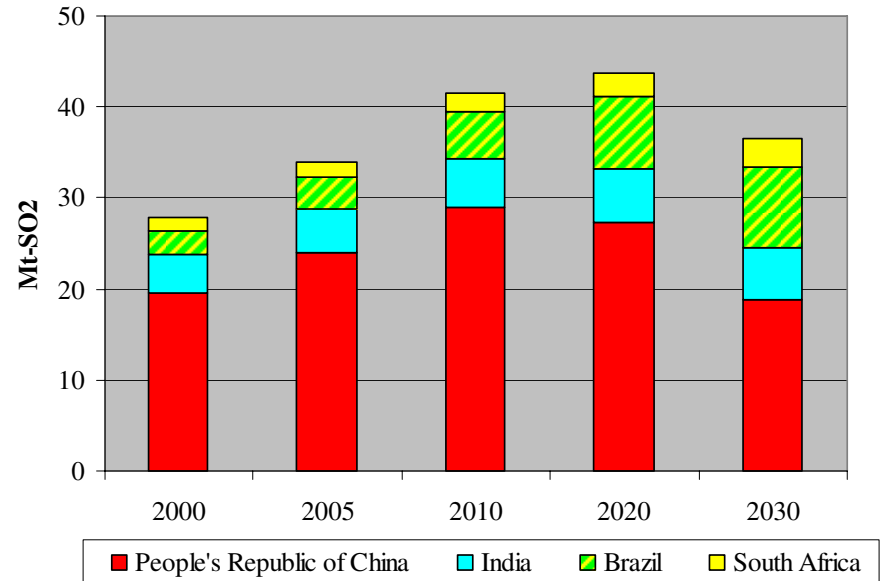
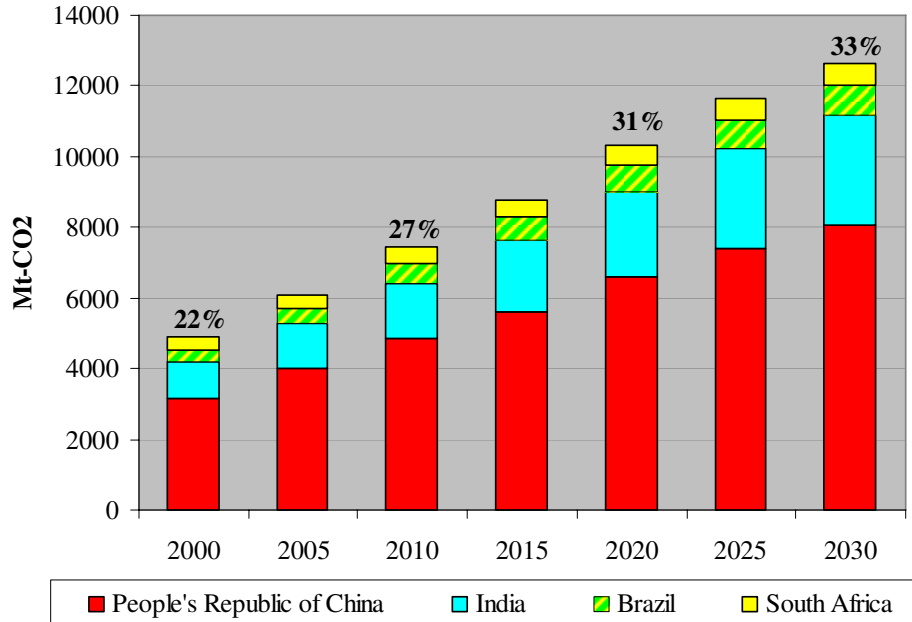

## Emission Relationships

- CO<sub>2</sub> and local pollutant emissions (e.g. SO<sub>2</sub>, NO<sub>x</sub> and particulates) decouple

- Elasticity of mitigating CO<sub>2</sub> as a side-benefit of SO<sub>2</sub> mitigation policy is lower (0.1-0.01 in 2020 for India) than elasticity of mitigating SO<sub>2</sub> as a side-benefit (1.2 to 1.4 in 2020 for India) from a direct CO<sub>2</sub> mitigation policy. Same for CO<sub>2</sub> and particulates. Similar trends for China.

- Policy relevance and investment implications

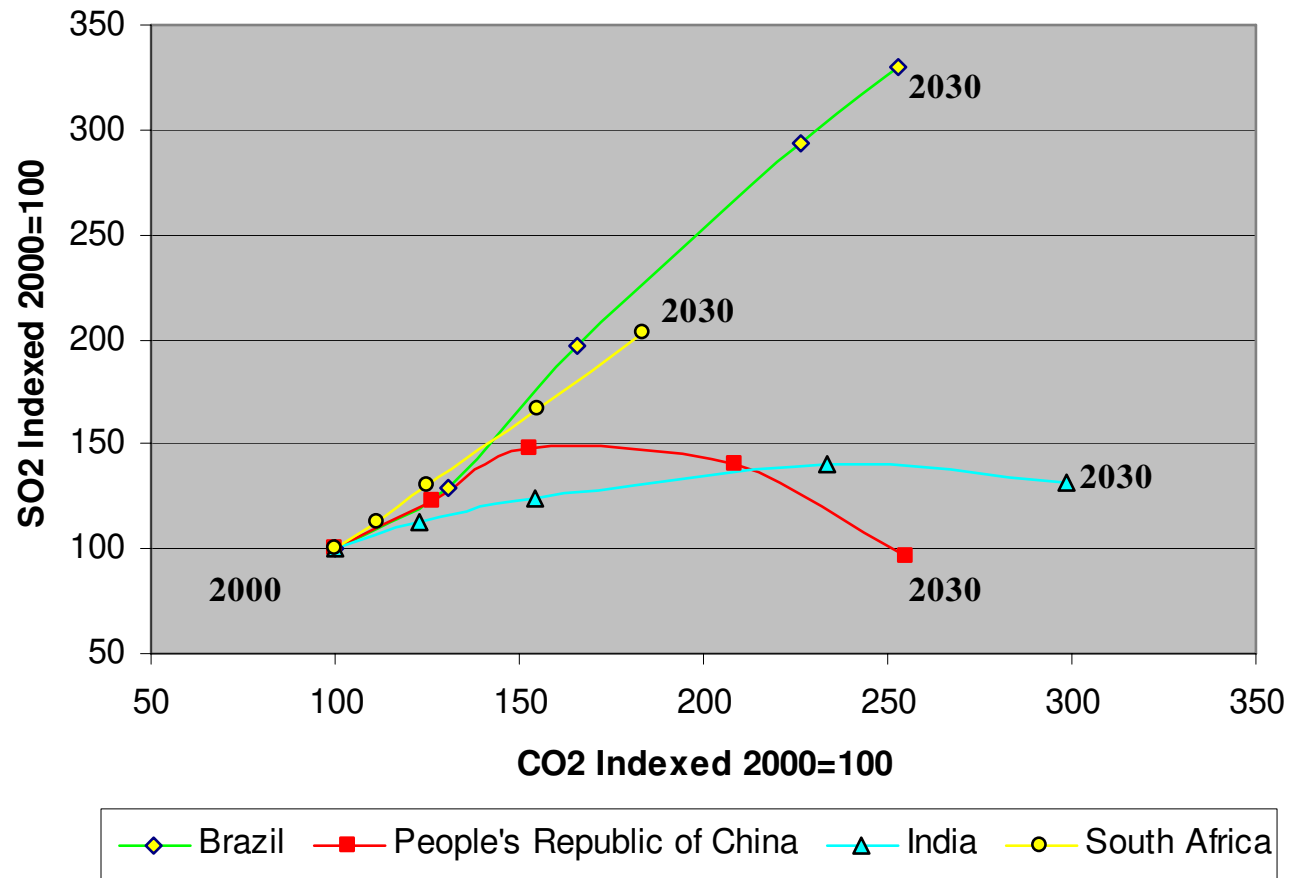

# **SD Indicators Linked with the Power Sector**



# Efficiency of Conversion (Energy used basis)

- Current efficiency of production is relatively lower, however projected to improve in future.
- China, India and South Africa consume over 40% of global coal, about 2/3<sup>rd</sup> is for power generation.

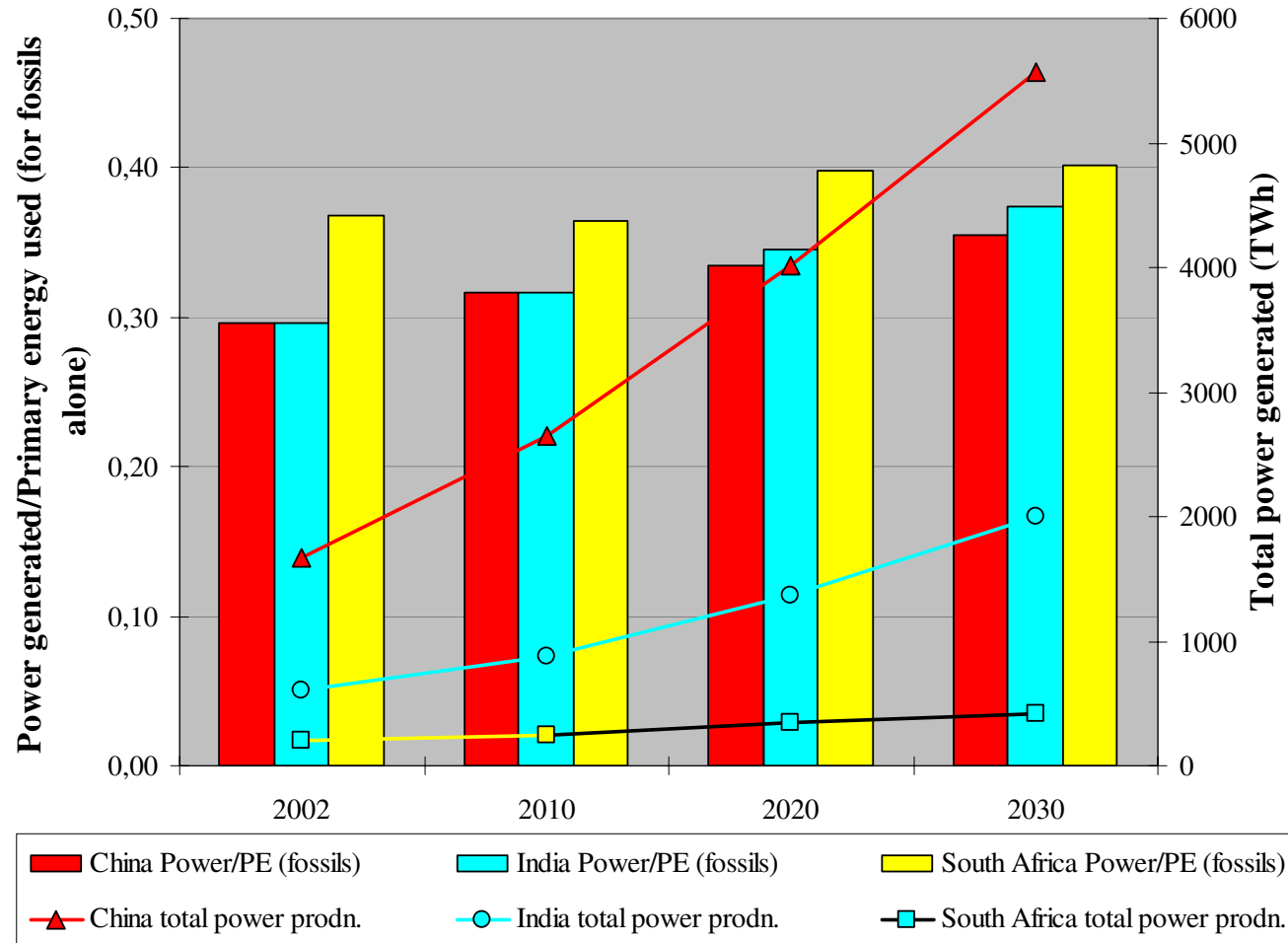

## Efficiency of Conversion (CO<sub>2</sub> emissions basis)

Average CO<sub>2</sub> emissions per unit of electricity generated are much higher than the best global practices

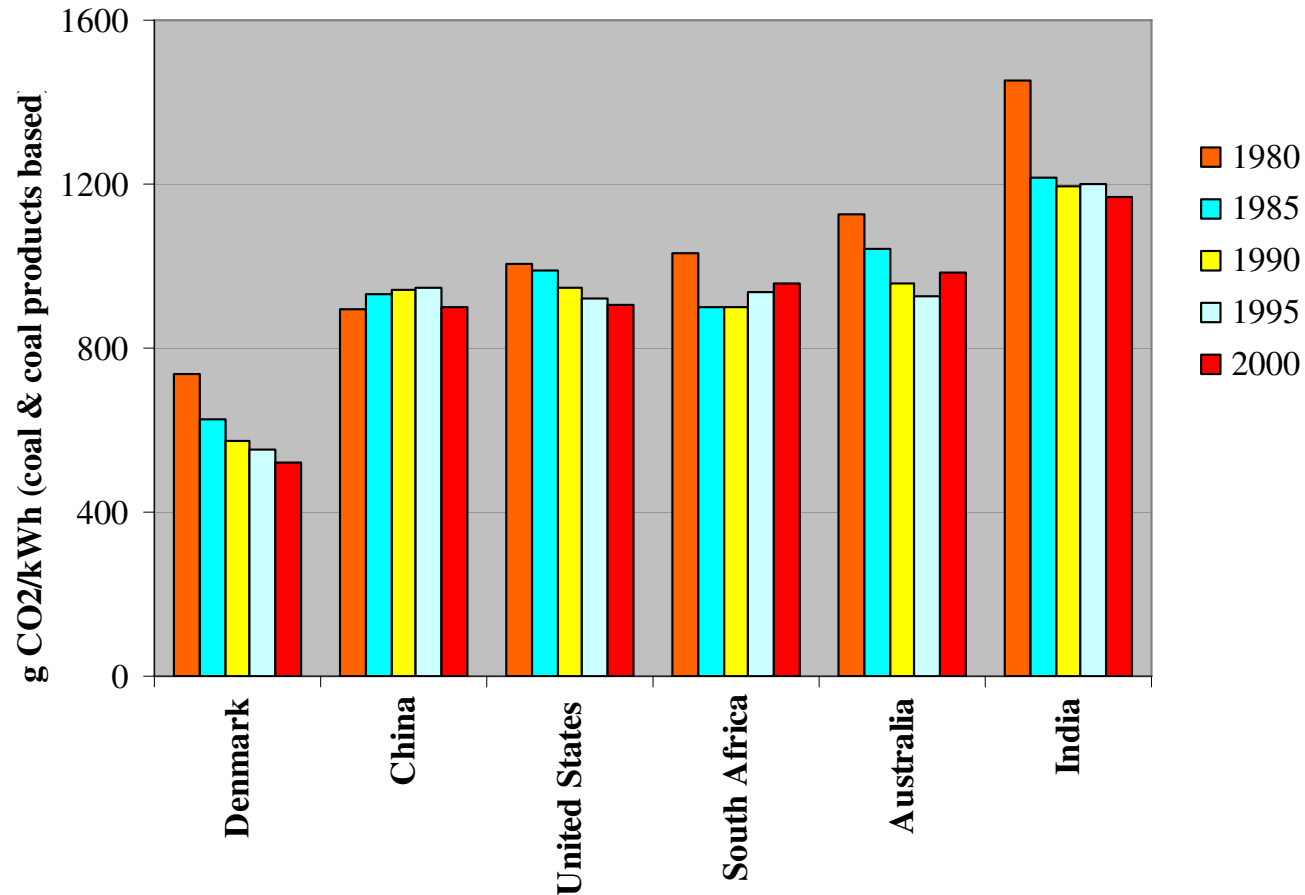

## General Conclusions about the Relationship between Development and Energy

- Reallocation of household time (especially by woman) from energy provision to improved education and income generation and greater specialisation of economic functions.
- Economics of scale in more industrial-type energy provision.
- Greater flexibility in time allocation through the day and evening.
- Enhanced productivity of education efforts.
- Greater ability to use a more efficient capital stock and take advantage of new technologies.
- Lower transportation and communication costs.
- Health related benefits: reduced smoke exposure, clean water and refrigeration.

## Households

HH income category	India rural, 2000		India urban, 2000		China urban, 2004	
	Absolute expenditure (USD, 2000 prices)	% share of total HH expenditure	Absolute expenditure (USD, 2000 prices)	% share of total HH expenditure	Absolute expenditure (USD, 2000 prices)	% share of total HH expenditure
Poorest 0-5%	0.46	10.2%	0.65	10.9%	3.00	10.3%
0-10%	0.51	10.1%	0.80	10.7%	3.33	9.8%
10-20%	0.62	9.0%	1.04	10.5%	4.10	8.7%
20-40%	0.73	8.7%	1.46	10.1%	4.79	7.9%
40-60%	0.97	8.9%	1.73	9.6%	5.57	7.2%
60-80%	1.15	8.6%	2.13	8.9%	6.55	6.6%
80-90%	1.44	8.1%	2.67	7.8%	7.67	6.0%
Top 90-100%	1.79	7.2%	4.01	5.7%	10.10	5.0%

## Households

**Table 2 Summary of How a Typical Household in Rural Philippines Benefits from Electricity, 1998**

<b>Benefit Category</b>	<b>Benefit Value US \$</b>	<b>Unit Per month</b>
Less expensive and expanded use of lighting	36.75	Household
Less expensive and expanded use of radio and television	19.60	Household
Improved returns on education and wage income	37.07	Wage earner
Time savings for household chores	24.50	Household
Improved productivity of home business	34.00 (current business) 75.00 (new business)	Business

Source: ESMAP, 2002 Table E-1

# Electricity Access and Affordability Indicators

- Reducing energy poverty, and enhanced electricity access for developmental goals is projected to increase electricity requirements during 2007-2030
- Coal based power is projected to remain the primary source - mainly due to energy security considerations
- Coal use becomes cleaner, but not clean enough.

## Access

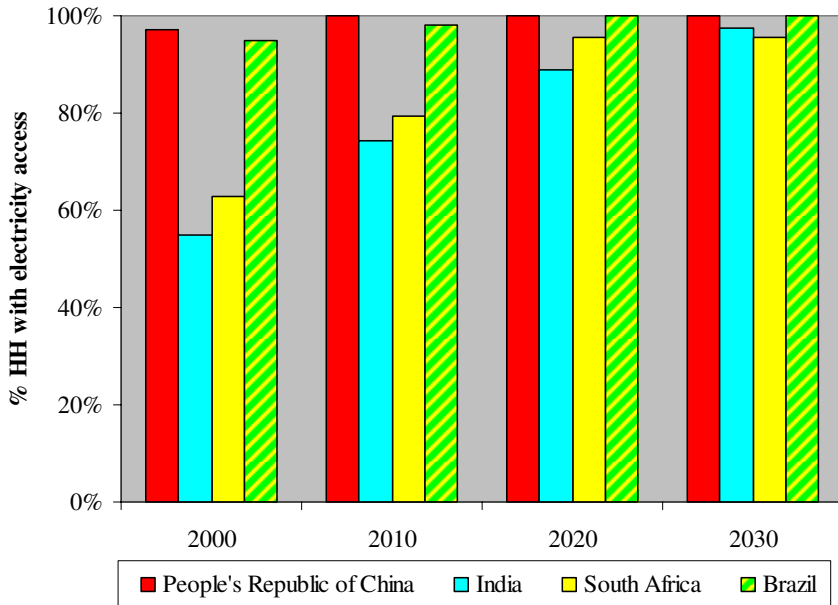

## Affordability

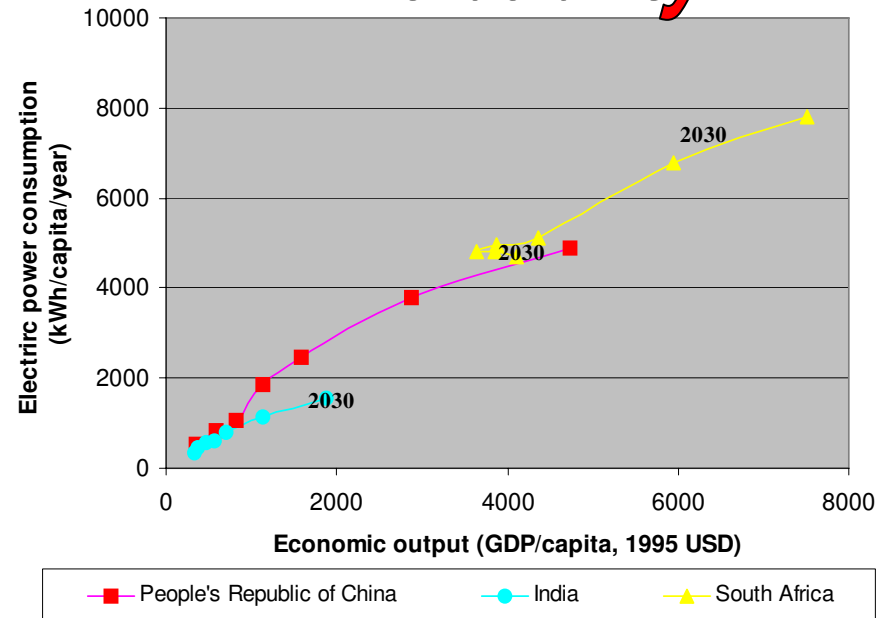

# Sustainable Development Indicators for China

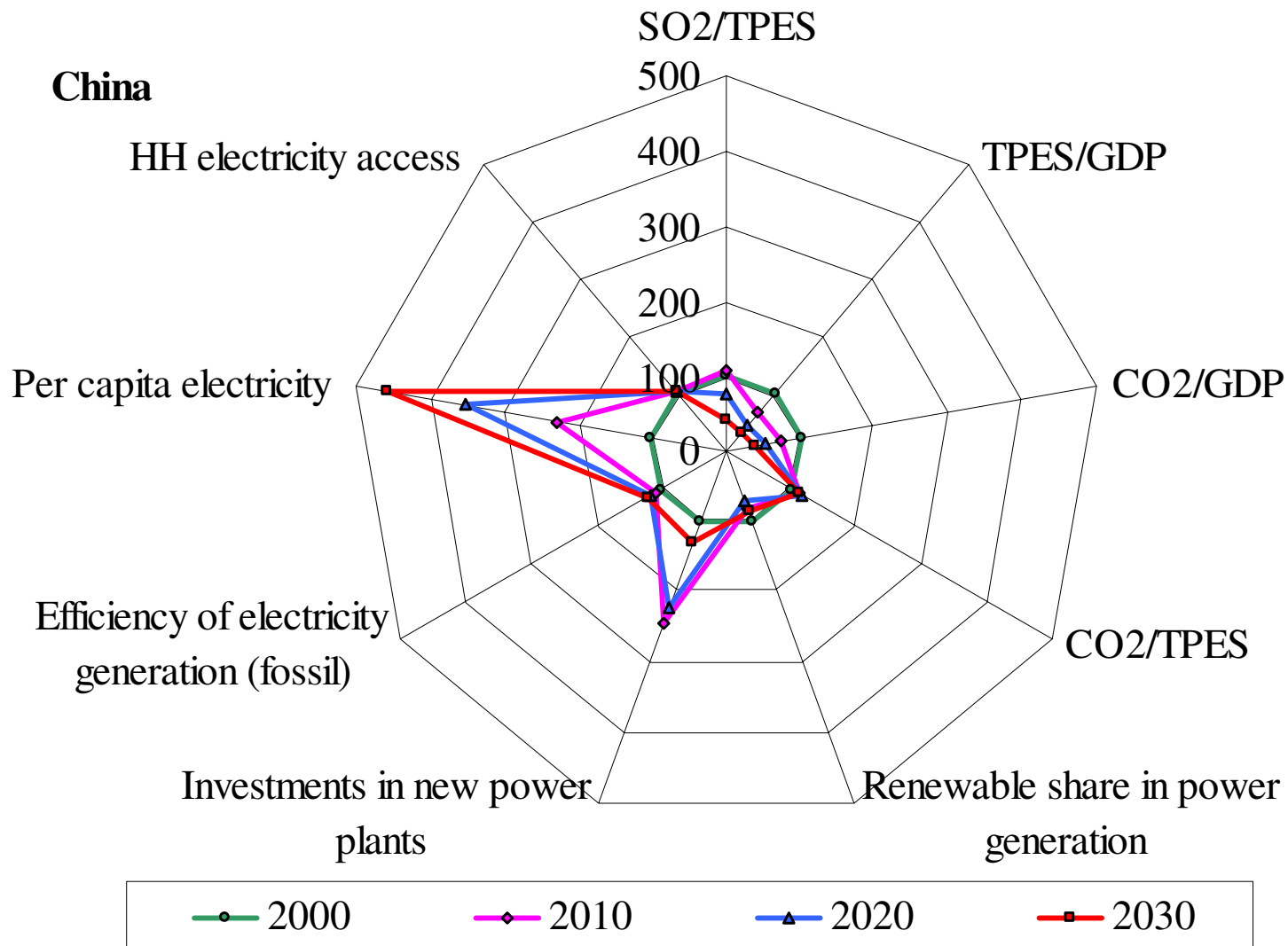

# Sustainable Development Indicators for India

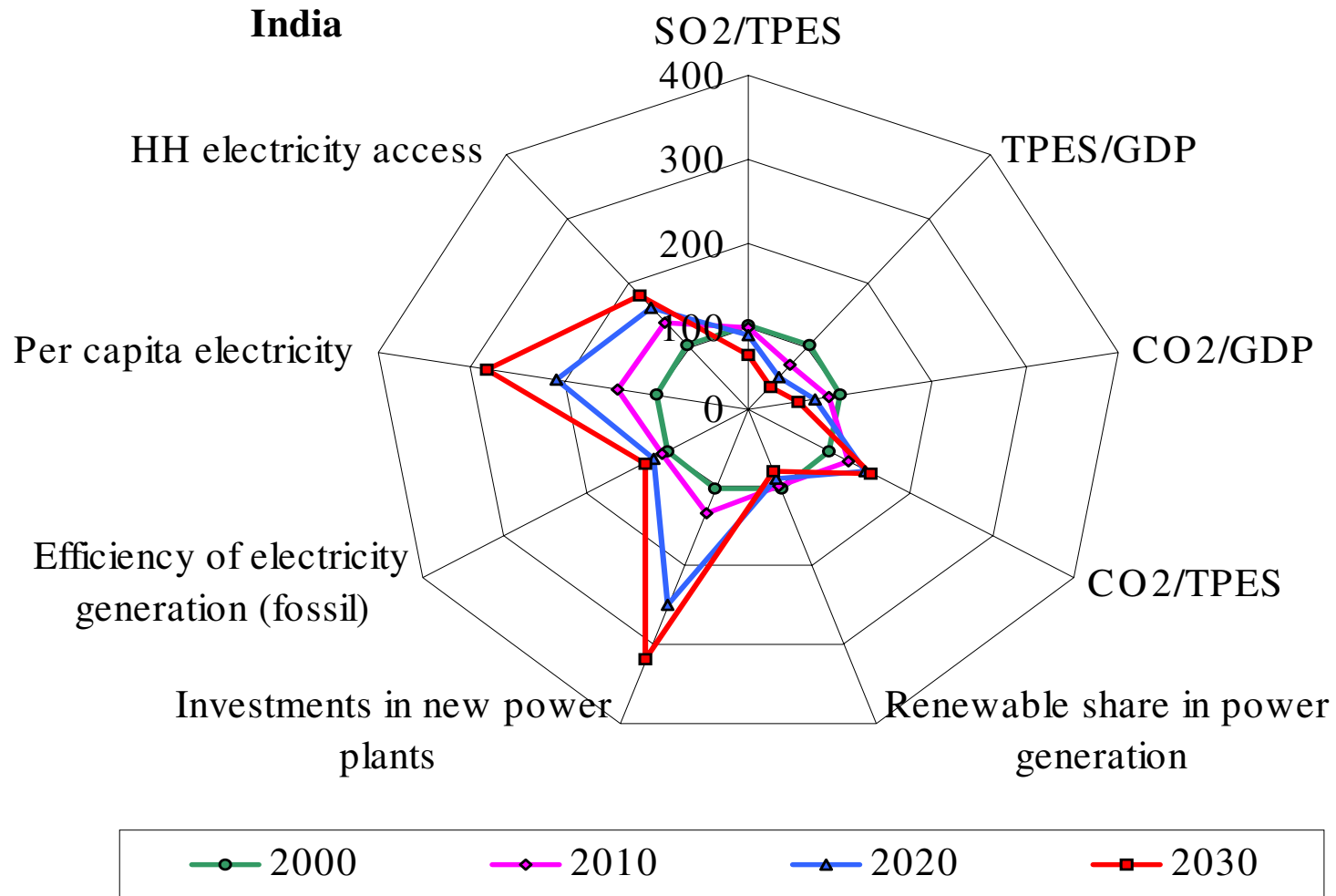



# Cross-country SDIs

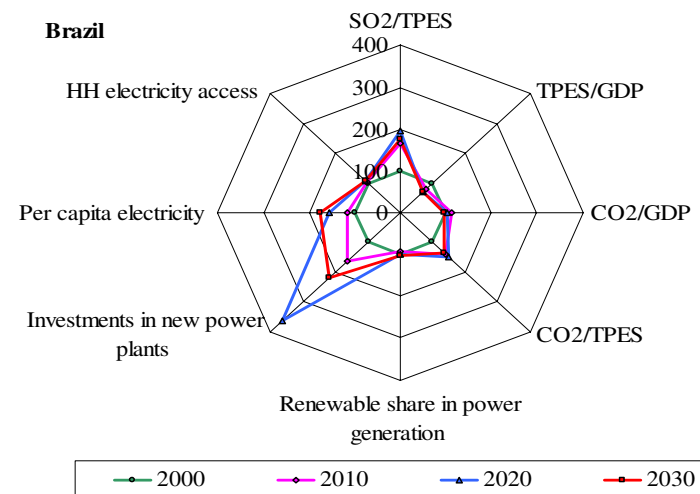
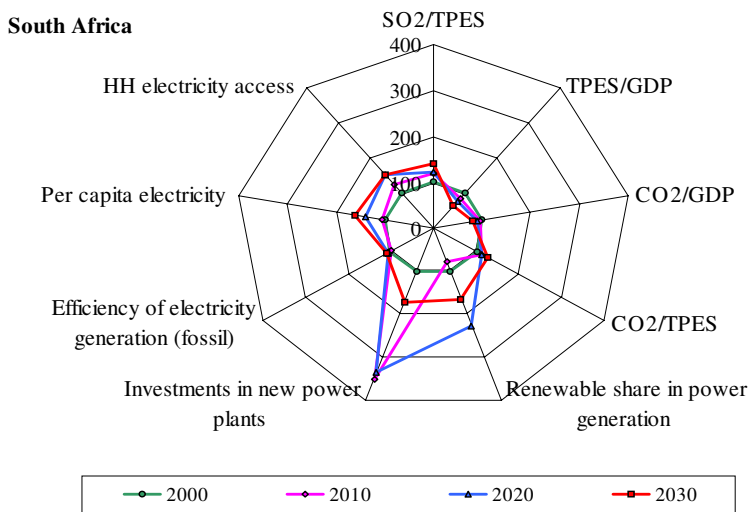
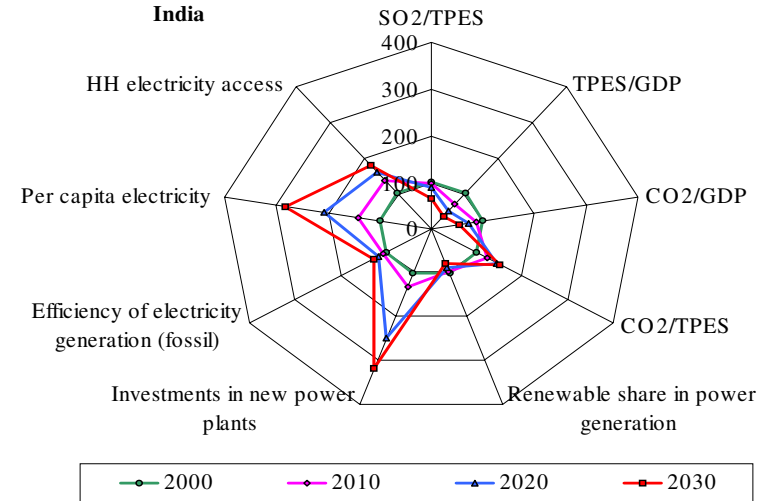
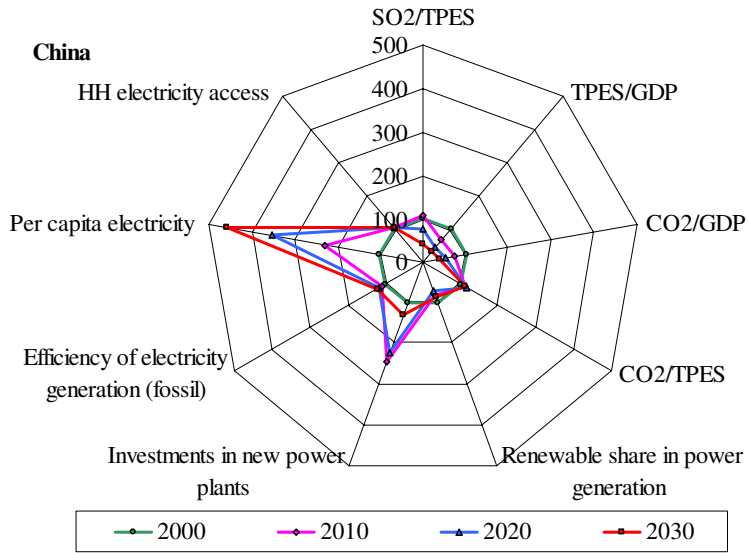

# **National Energy Case Studies of Climate Friendly Development**

## National Success Stories for China and India

Case example	Development impacts	Climate change mitigation/adaptation
<p>China: Energy efficiency in industry and power production</p>	<p>Local air pollution control, Energy cost savings in efficiency cases</p>	<p>Total SD scenario offers CO<sub>2</sub> reductions of 1.5 billion tC in 2030</p>
<p>India: South Asia energy-electricity market integration</p>	<p>Energy supply savings, cost savings, CO<sub>2</sub> and SO<sub>2</sub> emission reductions</p>	<p>1.4 billion tC and 50 million ton SO<sub>2</sub> saved over 30 years, Flood control, Reduced energy/electricity costs</p>

## National Success Stories for Brazil

Case examples	Development impacts	Climate change mitigation/adaptation
Ethanol programme	Employment, foreign exchange savings, local air pollution	9.45 MtC saved per year (17% of energy sector emissions in 1994)
Zero tillage to ensure higher content of organic matters in soil	Increased use of herbicides, energy cost savings	60-80 Mt CO <sub>2</sub> not released in 1999, 70% reduction in diesel consumption

## National Success Stories for South Africa

Case examples	Development impacts	Climate change mitigation/adaptation
Clean energy generation mix: Gas, hydro, renewables, nuclear	Energy security benefits, local environmental improvements	Annual CO <sub>2</sub> savings in 2025: 70 Mt CO <sub>2</sub>
Industrial energy efficiency in 3 major companies	Energy cost savings, local environmental benefits	Annual CO <sub>2</sub> savings of around 0.07 mtCO <sub>2</sub>

# **Analysing Alternative Pathways for Aligning SD, Energy and CC**

## Points of Intervention

- Business-As-Usual energy policies will not change the development path to a desirable climate friendly pathway
- We need to intervene at critical times (starting now) and through appropriate policies to change the development (and therefore emission) pathways
- These Points of Intervention could be, e.g.
  - Bringing in cleaner coal technologies for power generation
  - Biofuels
  - Rural electrification
  - Efficient transport (e.g. strengthening railway networks including metros)
  - Dematerialization of product designs at all levels
  - Cleaner fuels/technologies for cooking
  - Environmental education and consciousness at all levels

## Alternative Developmental Pathways for India: Comparative Performances

Parameters	IA1	IA2	IB1	IB2
Global equivalent Scenarios	Fossil intensive	Markets first	Global sustainability	regional solutions
GDP annual growth (2000-2030)	7.1%	5.5%	6.5%	4.2%
Cumulative Bt-CO <sub>2</sub> (2000-2030)	61	53	45	23
Per capita CO <sub>2</sub> in 2030 (ton-CO <sub>2</sub> )	2.3	1.8	1.7	1.4



## Development Path Transitions and CO<sub>2</sub> Emissions for India

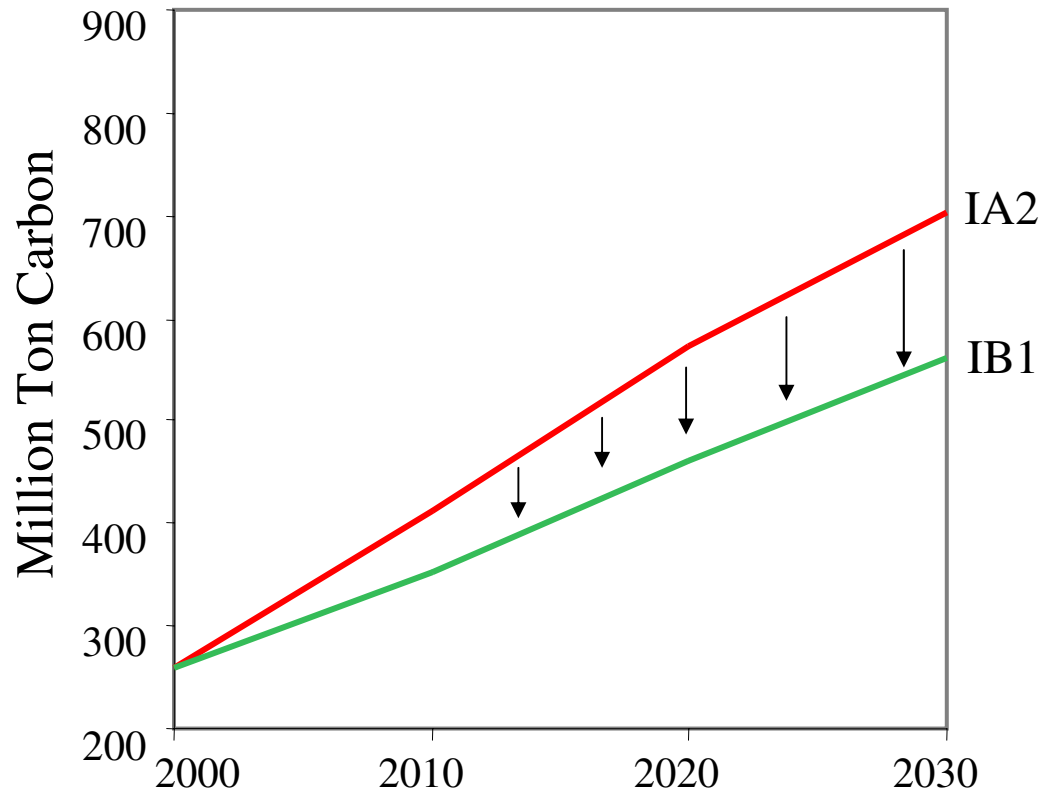

- Mitigate 8 Bt-CO<sub>2</sub> over 2000-2030 to transit from IA2 (Markets first) to IB1 (Global sustainability) pathway
- Welfare loss due to;
  - Mitigation costs (up to 1.5% GDP loss)
  - Other development paradigms and GDP follow IA2 scenario (and not IB1)
- Better to follow climate friendly development path from the beginning

## Clean Coal Technologies in China Under Alternative pathways

Sector	Technology	Share in 2030	
		Reference scenario	Alternative scenario
Power generation	Super Critical	25%	25%
Power generation	IGCC	4%	30%
Industry/Boiler	Advanced boiler	45%	75%
Industry/Kiln	Advanced kiln	38%	70%
Coal processing	Coal liquefaction	2% of total coal	10% of total coal
Desulphurization in power plants		58% of all plants	80% of all plants

## Promoting Clean Coal Technologies in China

Policy impacts on development, energy and climate change:

- Energy security
- Large employment to low income families that are employed with the production of the technologies (7.6 million people in 2004 and 7.8 million people in 2030)
- Establishment of a strong position for China on international markets for cleaner coal technologies
- Reduction in local and global emissions

## Key Lessons Learnt

- BAU energy policies of large developing countries will not align their national developmental goals with global climate change mitigation concerns
- Integration of climate and broader SD concerns early in energy policy process (path change) is cost-effective both from development and climate change perspectives
- Each country has to choose its own development pathway. Diversity of alternative opportunities, projects and approaches exist
- National case studies demonstrate that many dedicated development policies and activities make ("unintended") positive climate contributions
- Quantifying development and climate change impacts of energy policies enhances policy relevance of the research considerably
- The 'non-climate' route for international climate change policy making is feasible and cost-effective
- Main challenge is implementation

**Thanks**

# Sustainable Transport Practices in Latin America

Risø International Energy Conference 22-24 May 2007  
Energy Solutions for Sustainable Development

Jorge Rogat and Miriam Hinostroza  
UNEP Risø Centre  
Roskilde, Denmark

## The Transport Situation in Latin America

- Lack of efficient, reliable and safe public transport systems
- Excessive number of old, unsafe and highly polluting buses
- Deregulated sector
- Lack of resources and political will
- Steadily increasing private motorisation in the region (250% increase in the car fleet between 1970 and 1990)
- Increased congestion, number of accidents and air pollution

## The turning point

- Need to reformulate transport policies with the aim of providing safe, cost-effective, and environmental-friendly public transport systems
- Curitiba in Brazil became the first city in Latin America to rethink transport policies and found in integrated urban planning and mass rapid transit, with BRT (Bus Rapid Transit) as the main component, the answer to the problem



- The example was first followed by Bogota, Colombia with the implementation of Transmilenio
- Today BRT systems have been implemented, or are in the implementation phase in Guayaquil, Ecuador; Guatemala City, Santiago, Chile and other LA cities

- BRT systems have been implemented or are planned in Jakarta, Indonesia; Beijing, China; Bangkok, Thailand; Nantes, France, Eindhoven, Netherlands; Boston and Orlando in the USA; Adelaide, Australia
- Unique example of South-South, South-North technology transfer

### **Definition of BRT**

is a system that emphasises priority for rapid movement of buses by securing segregated busways (IEA, 2002)

## How do BRT systems work?

- In a similar way to light-rail trains or rail-based metros, but operate along corridors on dedicated busways at street level
- Use articulated buses with a carrying capacity of around 160 passengers or bi-articulated buses (270 passengers)
- Supplemented by feeder buses
- Modal integration complementing other transport systems
- Can carry up to 35,000 passengers per hour an direction
- Rapid boarding
- Public-private partnership

## Successful practices

### Curitiba's Integrated Transport Network (ITN)

- Integrates land use and public transport under joint public-private operation with emphasis on equity and affordability
- Government officials started in the 60s to work on a master plan
- Restructured the city's radial configuration into a linear model of urban expansion

- Three-part road system with each axis made up of a central street with special lanes for efficient public transportation
- In 1971 Jaime Lerner developed plans for the ITN of Curitiba
- Favouring public transport, using appropriate rather than capital-intensive technologies

In 1974 the first BRT system in Latin America was operational

- ✓ Thirteen express routes with direct routes using boarding tubes
- ✓ Twenty eight routes including special buses for students and the disabled
- ✓ Approximately 1900 buses of which 500 articulated buses (160) and 300 bi-articulated buses (270) that carry around 2 million passengers/day or about 75% of the total number of passengers

- ✓ Around 58 km of dedicated busways along 5 corridors complemented by 270 km of feeder routes and 185 km of inter-district routes
- ✓ Feeder and inter-district routes supplemented by city centre routes
- ✓ Prepaid boarding (one ticket) through 25 transfer terminals and 221 tube stations

# Curitiba





## Bogota's Transmilenio

- With Curitiba as the source of inspiration, but taking into consideration prevailing local conditions
- More because of the chaotic transport problem affecting the mega city than the aim of urban development as in the case of Curitiba
- A component of the city's Mobility Strategy

- To provide an efficient, safe and comfortable mass rapid transit system for the people
- With emphasis on affordability meaning: (1) possible for the government to afford the infrastructure; (2) for the private sector to recover costs of bus acquisition and operations and; (3) for the users to pay the fare

Transmilenio was launched in December 2000

- ✓ The BRT system is currently composed of about 800 articulated buses and 470 feeder buses
- ✓ Covers about 400 km along 22 dedicated busways with 2 lanes in each direction
- ✓ Carries up to 45 thousand passengers per hour and direction
- ✓ Managed by public-private partnership
- ✓ It aims at transporting 80% of the people of Bogotá by 2015

# Transmilenio



## Some of the new initiatives

### Guayaquil's Metrovía

- Metrovía is the main component of the Massive Urban Transport (MUTP) Programme of Guayaquil
- Like in Bogotá it is thought to be the answer to the problems affecting the transport sector
- The main objective of the MUTP is to provide an efficient, safe, reliable, fast and affordable public transport system to the 84% of the population using public transportation

The first corridor introduced in August 2006

- ✓ Uses 72 articulated buses and 69 conventional buses as feeder buses
- ✓ It's expected to carry 140 thousand passengers per day
- ✓ Prepaid boarding
- ✓ Managed by a public-private partnership
- ✓ When the complete BRT is in place (2020), 7 corridors will be operational



# Metrovía



## Guatemala City's Transmetro

- First replication of Curitiba and Transmilenio in Central America
- Main component of the Urban Mobility Plan for 2020
- Main objective to provide reliable, safe and affordable transport services for the people
- To decrease congestion, vehicle operational costs, travel time, traffic accidents, energy consumption and local air pollution
- Transmetro is considered key in achieving these objectives



First corridor operational in February 2007

- ✓ Managed by a public-private partnership
- ✓ New and cleaner articulated buses with a carrying capacity of 160 passengers (48 articulated buses of which 17 are new)
- ✓ Replace 4-5 old buses by a new bus
- ✓ The system is expected to transport 180 thousand passengers per day
- ✓ When completed in 2020 it will be composed of 12 corridors

# Transmetro



## Santiago's Transantiago

- One of the components of a comprehensive restructuring of the whole public transport sector designed by the government of Chile in 1995
- Main objectives are: (1) to solve the current transport problems; (2) to maintain the current 50% ridership; (3) to provide a reliable and safe public transport system and; (4) to develop a modern, environmentally clean and economically efficient public transport system
- Is being implemented by various ministries
- When completed will consist of 5 corridors

## Transantiago was launched in February 2007

- ✓ It has been integrated with the Metro and with urban and interurban trains
- ✓ It uses around 4,700 buses (1,200 new buses) including articulated and conventional feeder buses instead of 7,500 used before
- ✓ Feeder buses complement both the BRT and the Metro
- ✓ Fare collection through smart electronic prepaid cards
- ✓ Fare depending on the numbers of transfers made but with a maximum fare of US\$0.80



# Transantiago



## Results

### Curitiba's ITN

- 30% previously travelled by car
- 27 million fewer trips made by car
- per capita fuel consumption has decreased by 30%
- air pollution is the lowest in the country

## Transmilenio

- 90% fewer traffic accidents
- about 40% less air pollution
- 40% reduction in travel time
- 90% passenger satisfaction

## Metrovía

- High passenger satisfaction
- 97% on-time performance on both trunks and feeders
- Increased travel speed from 16 to 22km



## Transmetro

- High passenger satisfaction
- Increased safety
- 80% reduction in travel time

## Transantiago

- Extremely low passenger satisfaction
- Increased travel time ( 20 to 30 minutes)
- The Metro has collapsed

## Conclusions

- Well planned and implemented BRT systems have proven to be the right transport solution in many cities
- BRT systems can provide high quality services similar to other MRT systems like light-rail trains or metro
- High political will reflected in continued local transport policy aimed at favouring the use of public transport
- Urban planning compatible with innovative public transport solutions

- Appropriate rather than capital-intensive technology:  
BRT cost/km 2 – 5US\$ million while rail based metro 60 - 200US\$ per km
- Participatory approach
- Gradual changes in passengers' habits





**Risø International Energy Conference 2007**  
**24<sup>th</sup> May 2007**

# **Environmental Analysis of Coal-based Power Production with Amine-based Carbon Capture**

W. Kuckshinrichs<sup>1</sup>  
J. Nazarko<sup>2</sup>, A. Schreiber<sup>1</sup>, P. Zapp<sup>1</sup>

Institute of Energy Research  
1 Systems Analysis and Technology Evaluation (IEF-STE)  
2 Fuel Cells (IEF3)  
Forschungszentrum Jülich GmbH



1. Introduction
2. CO<sub>2</sub> capture concepts
3. Methodology and basic parameters
4. Inventory analysis
5. Impact assessment
6. Summary and outlook



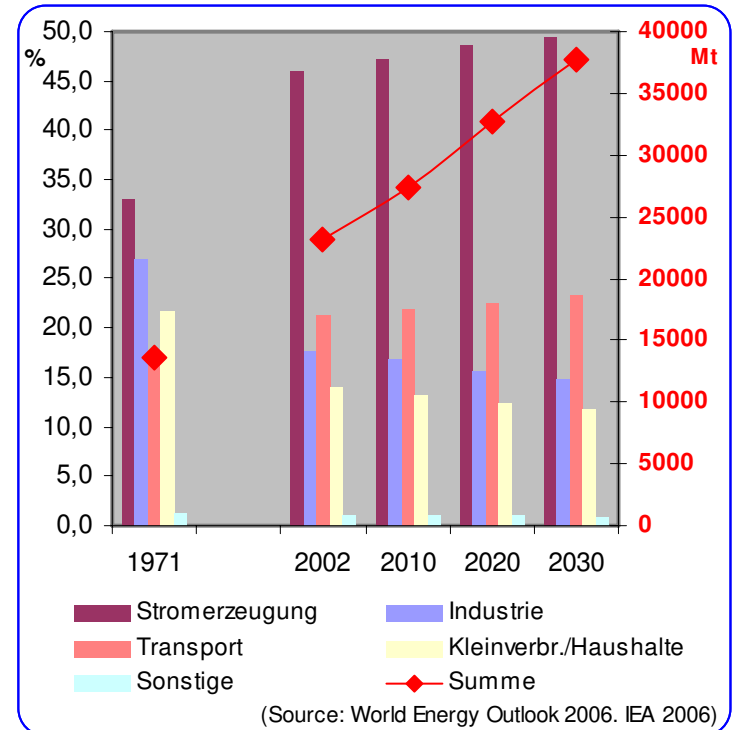
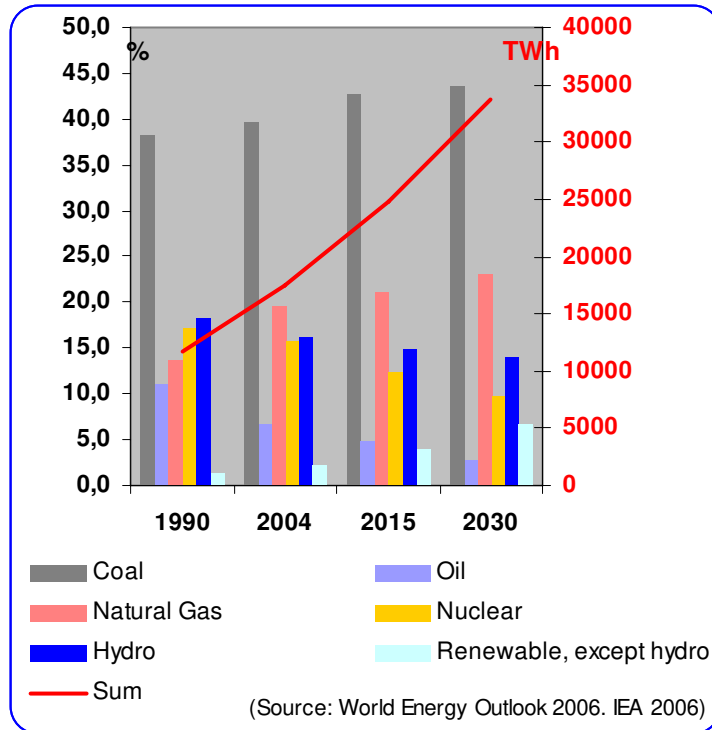

- Increase of future global electricity demand
- Strong dependency on fossil-based power generation (coal, gas)
- Increasing share of renewable energies
- Decreasing share of nuclear power and hydropower

- Increasing global CO<sub>2</sub> emissions
- Share of CO<sub>2</sub> from transport increasing
- Share of CO<sub>2</sub> from industry and households decreasing
- Share of CO<sub>2</sub> from power generation increasing, unless measures like CCS are taken



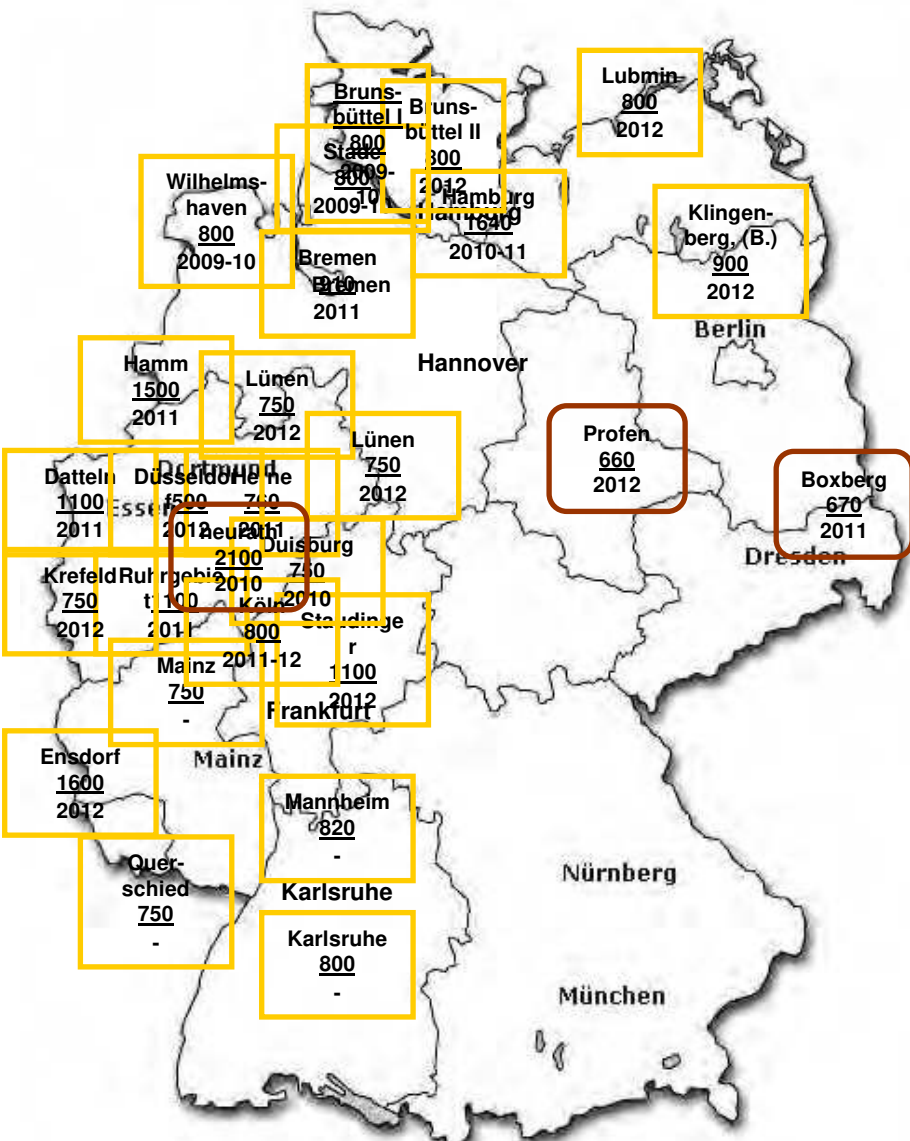

- Worldwide investment in fossil-based power generation capacity expected
- European Union: Announced construction of new plants
- Coal and gas power generation in Germany: 27 announcements of new power plants (coal, lignite), 25,000 MW

location  
capacity  
year coal

location  
capacity  
year lignite

(Source: Handelsblatt, VDEW, BUND)



# CO<sub>2</sub> capture concepts

Concepts	Energy supply perspective: Assets (+) and drawbacks (-)	Environmental impacts: Assets (+) and drawbacks (-)
Post combustion: CO <sub>2</sub> capture from flue gas	<ul style="list-style-type: none"> <li>+ technology available</li> <li>+ retrofitting possible</li> <li>- high energy penalty</li> <li>- high cost increase</li> </ul>	<ul style="list-style-type: none"> <li>+ reduced net CO<sub>2</sub> emissions</li> <li>? process inputs</li> <li>? process outputs</li> </ul>
Oxyfuel: CO <sub>2</sub> concentration in flue gas	<ul style="list-style-type: none"> <li>+ compact boiler design</li> <li>+ high retention rates</li> <li>- high e-penalty for air sep.</li> <li>- high invest cost</li> </ul>	<ul style="list-style-type: none"> <li>+ reduced net CO<sub>2</sub> emissions</li> <li>? process inputs</li> <li>? process outputs</li> </ul>
Pre combustion: CO <sub>2</sub> capture from syngas after CO-shift	<ul style="list-style-type: none"> <li>+ lower e-penalty</li> <li>+ hydrogen production</li> <li>- technical availability of IGCC</li> <li>- complex CO<sub>2</sub> capture</li> </ul>	<ul style="list-style-type: none"> <li>+ reduced net CO<sub>2</sub> emissions</li> <li>? process inputs</li> <li>? process outputs</li> </ul>



Method for assessment of environmental impacts throughout the life cycle of a product / technique from raw material acquisition through production, use, end-of-life treatment and disposal

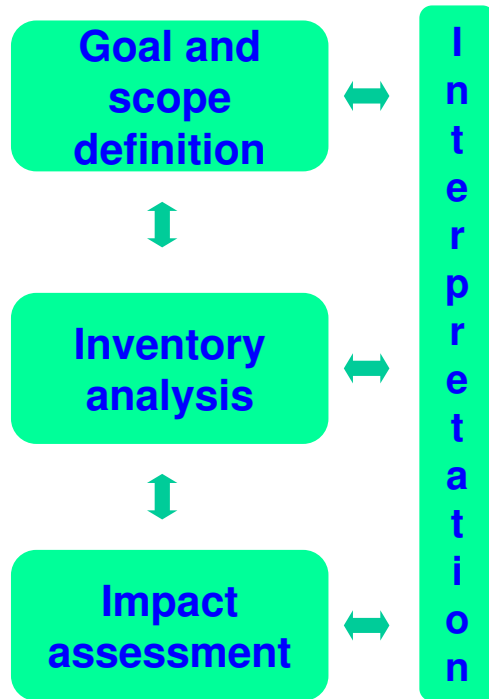

## Phases of LCA

Reference: ISO 14040, 14044, 2006

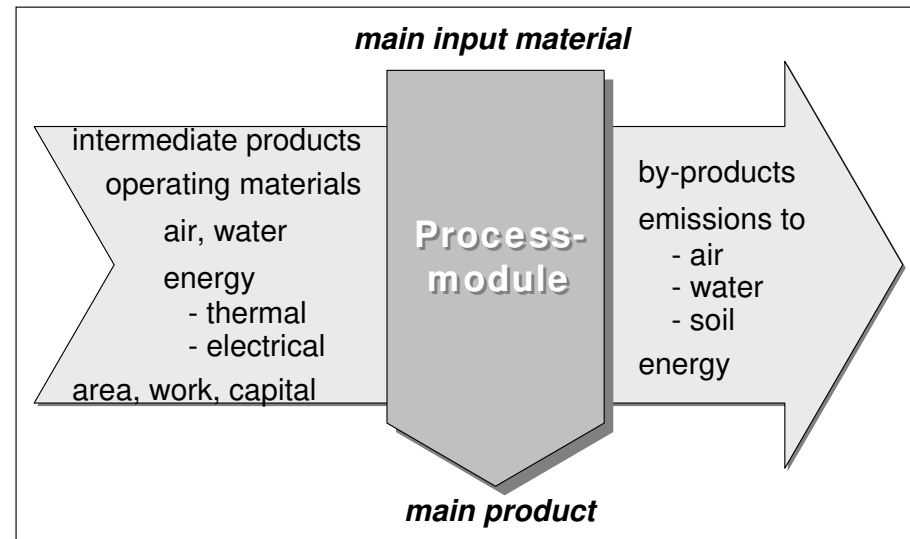

## Unit process



## Goal and scope definition

- Environmental impact analysis of coal-based power generation without and with MEA-based CO<sub>2</sub> capture
- No upstream and downstream activities
- Geography: Germany, Europe
- Point in time: 2005 – 2010 – 2020
- Functional unit: 1 kWh<sub>el</sub>

### ***“Conventional” pulverized coal power plants***

1. Coal plant<sub>2005</sub>: operating in 2005
2. Coal plant<sub>2010</sub>: installed in 2010
3. Coal plant<sub>2020</sub>: installed in 2020

### ***Pulverized coal power plants with Amine-based carbon capture***

4. MEA<sub>retrofit1</sub>:  
Coal plant<sub>2005</sub> + MEA<sub>2020</sub> retrofitted in 2020
5. MEA<sub>retrofit2</sub>:  
Coal plant<sub>2010</sub> + MEA<sub>2020</sub> retrofitted in 2020
6. MEA<sub>greenfield</sub>:  
Coal plant<sub>2020</sub> + MEA<sub>2020</sub> installed in 2020



## Power plant and CO<sub>2</sub> capture: Processes and system boundaries

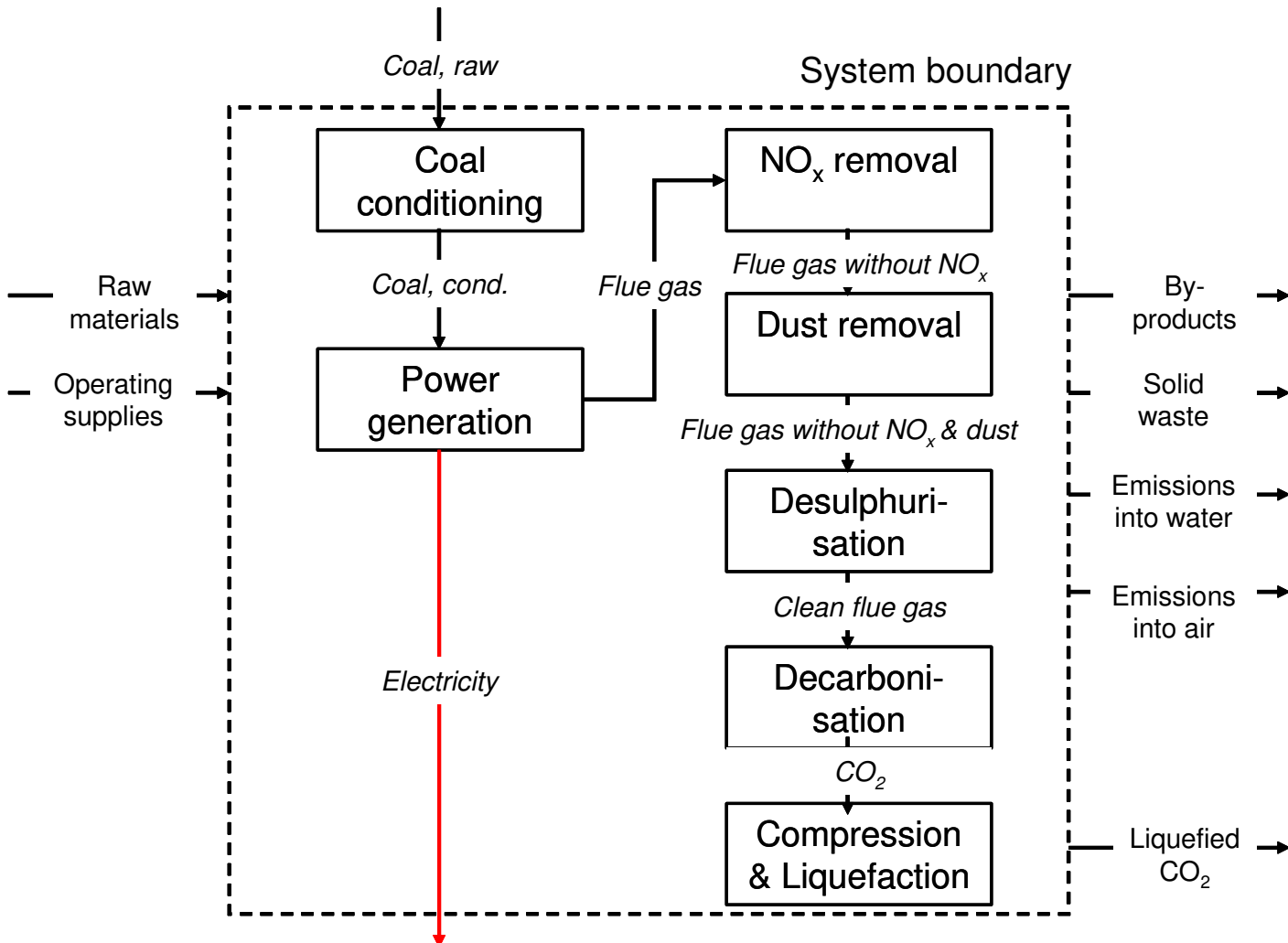



## Technical parameters of the power plants

<i>Plant parameter</i>	unit	Coal plant <sub>2005</sub>	Coal plant <sub>2010</sub>	Coal plant <sub>2020</sub>	MEA <sub>retrofit1</sub>	MEA <sub>retrofit2</sub>	MEA <sub>greenfield</sub>
combustion capacity	MW <sub>th</sub>	1164	1200	1424	1164	1200	1424
gross capacity	MW <sub>el</sub>	550	600	750	479	527	707
net capacity	MW <sub>el</sub>	500.5	552.0	697.0	378.6	426.5	592.0
gross efficiency	%	47.3	50.0	52.7	41.1	43.9	49.6
net efficiency	%	43.0	46.0	49.0	32.5	35.5	41.6
electrical equivalence factor	----	----	----	----	0.2	0.2	0.1

- Coal plant<sub>2005</sub> – coal plant<sub>2020</sub>

- Increase of net capacity
- Increase of net efficiency: 43% to 49%

- MEA<sub>retrofit1</sub> - MEA<sub>greenfield</sub>

- Increase of net capacity
- Decrease of energy penalty: 10.5 to 7.4%points
- Decrease of electrical efficiency factor



## Inputs

<i>Inputs g/kWh<sub>el</sub></i>	Coal plant <sub>2005</sub>	Coal plant <sub>2010</sub>	Coal plant <sub>2020</sub>	MEA <sub>retrofit1</sub>	MEA <sub>retrofit2</sub>	MEA <sub>greenfield</sub>
hard coal	282	264	247	373	341	291
cooling water	1398	1222	1077	2126	1834	1389
ammonia	0.63	0.58	0.54	0.84	0.75	0.64
lime stone	23	22	20	30	28	24
MEA	0	0	0	2.3	2.1	1.1
sodium hydroxide	0	0	0	0.12	0.11	0.09

■ Coal plant<sub>2005</sub> – coal plant<sub>2020</sub>

- Reduction of hard coal and cooling water
- Reduction of ammonia and lime stone
- No MEA solution and sodium hydroxide

■ MEA<sub>retrofit1</sub> - MEA<sub>greenfield</sub>

- Higher, but decreasing level of hard coal and cooling water
- Higher, but decreasing level of ammonia and lime stone
- Decreasing use of MEA solution and sodium hydroxide
- MEA<sub>greenfield</sub> most attractive



## Output: CO<sub>2</sub>

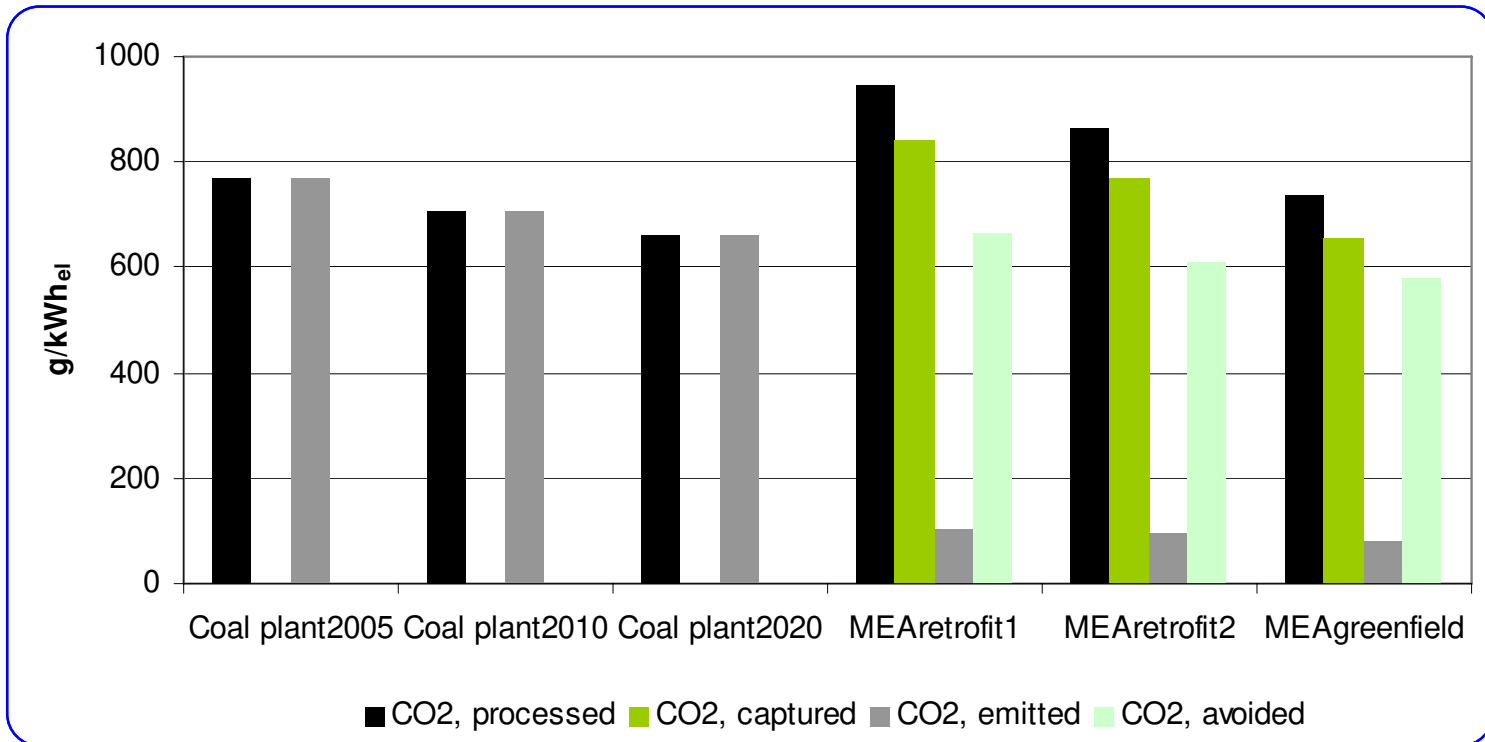

### ■ Coal plant<sub>2005</sub> – coal plant<sub>2020</sub>

- CO<sub>2</sub> processed = CO<sub>2</sub> emitted
- Less carbon dioxide processed

### ■ MEA<sub>retrofit1</sub> - MEA<sub>greenfield</sub>

- Higher, but decreasing level of CO<sub>2</sub> processed
- Fixed share of carbon dioxide captured
- Lower and decreasing level of CO<sub>2</sub> emitted
- Decrease of carbon dioxide avoided
- MEA<sub>greenfield</sub> most attractive





## Further outputs

<i>Outputs g/kWh<sub>el</sub></i>	Coal plant <sub>2005</sub>	Coal plant <sub>2010</sub>	Coal plant <sub>2020</sub>	MEA <sub>retrofit1</sub>	MEA <sub>retrofit2</sub>	MEA <sub>greenfield</sub>
waste heat	590	552	518	1179	1076	920
waste water	120	113	106	159	146	126
gypsum (FGD)	40	37	35	52	48	42
waste, sludge, slag	0.90	0.85	0.79	1.26	1.15	1.01
hazardous waste	---	---	---	3.46	3.07	1.22

### ■ Coal plant<sub>2005</sub> – coal plant<sub>2020</sub>

- Decrease of waste heat and waste water
- Decrease of gypsum
- Decrease of waste, sludge and slag

### ■ MEA<sub>retrofit1</sub> - MEA<sub>greenfield</sub>

- Higher, but decreasing level of waste heat and waste water
- Higher, but decreasing level of gypsum, waste, sludge and slag
- New: hazardous waste (decreasing level)
- MEA<sub>greenfield</sub> most attractive



## Selected results of the impact assessment

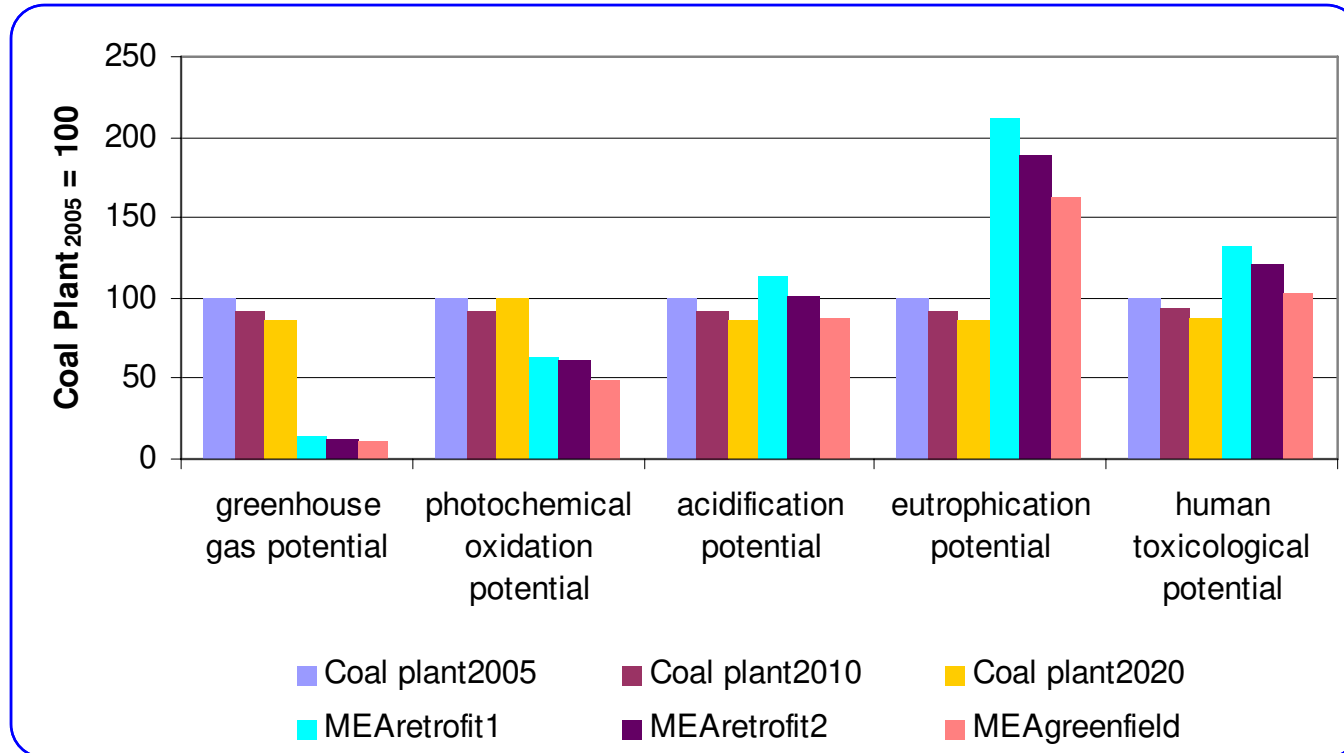

- For greenhouse gas potential and photochemical oxidation potential clear advantage for MEA-based capture
- For acidification potential no clear advantage for MEA-based capture
- For human toxicological potential MEA-based capture unfavourable
- For eutrophication potential clear disadvantage for MEA-based capture



- High, but decreasing level of energy penalty
  - Higher level of material and energy flows and additional flows
  - Less CO<sub>2</sub> emissions and global warming potential
  - Higher level of other emissions and additional emissions
  - Subsequently higher level for some environmental impacts
- 
- MEA-based technology superior with respect to CO<sub>2</sub>
  - MEA<sub>greenfield</sub> most favorite capture technology
  - No clear advantage for MEA-based capture taking into account other environmental impacts



## Future activities for plant-related analysis:

- Inclusion of CO<sub>2</sub> transport and storage and up- and downstream processes
- Analysis of other capture routes and technologies (pre combustion and oxyfuel)

## Future activities for full capacity-related analysis:

- Adaptation of plant-related results for dynamic analysis taking into account capacity development



**Thank you for your attention**

# Solid Oxide Electrolysis for Fuel Production

Sune D. Ebbesen, Anne Hauch, Søren H. Jensen, and Mogens Mogensen

Fuel Cell and Solid State Chemistry Department  
Risø National Laboratory, Technical University of Denmark  
DK-4000 Roskilde, Denmark

*[www.risoe.dk](http://www.risoe.dk)*

*[Sune.Ebbesen@risoe.dk](mailto:Sune.Ebbesen@risoe.dk)*

Risø International Energy Conference, 23<sup>rd</sup> May 2007

# Outline

## Solid Oxide Electrolysis for Fuel Production

1. Principle for **S**olid **O**xide **E**lectrolysis **C**ells (SOECs)
  - Production of hydrogen and synthetic fuel
  - Advantages of SOEC compared to PEM/Alkaline electrolysis
2. Perspectives for SOECs
  - Economy estimation for hydrogen production
  - Synthetic fuel
3. Conclusions and what about the future ?

# Principle for SOECs

## Solid Oxide Fuel Cells

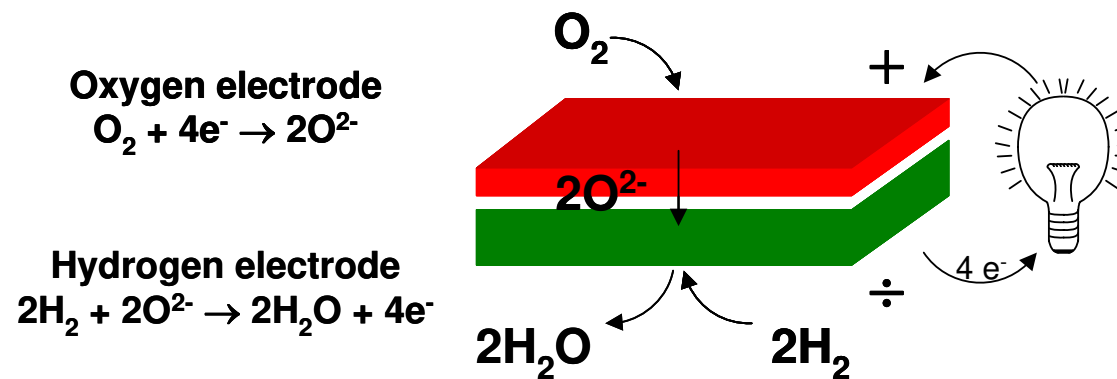



# Principle for SOECs

Solid Oxide Electrolysis Cells

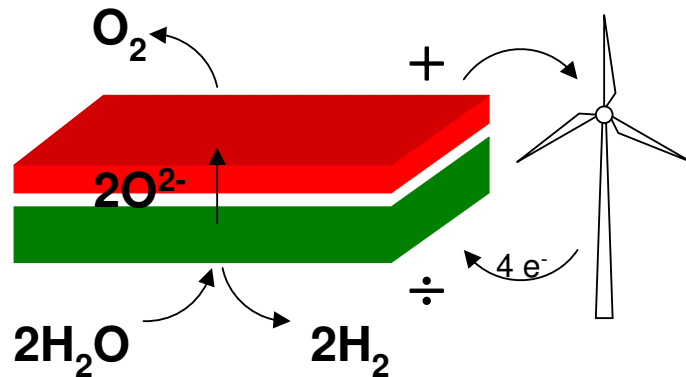

Consuming water and electricity  
 Producing hydrogen  
 Electrolysis of  $\text{CO}_2 + \text{H}_2\text{O}$  to  
 synthesis-gas ( $\text{CO} + \text{H}_2$ )

Solid Oxide Fuel Cells

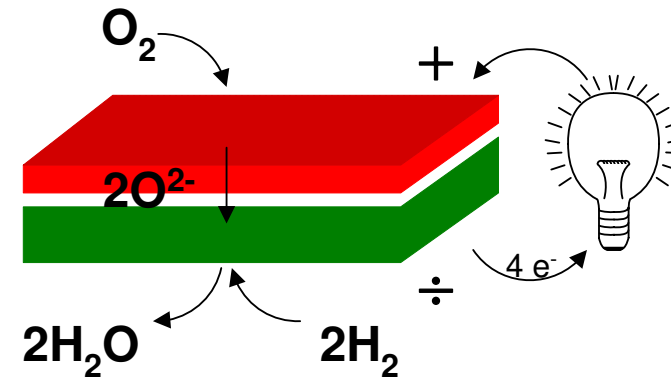

Consuming hydrogen  
 Producing electricity

# Principle for SOECs

## Solid Oxide Electrolysis Cells

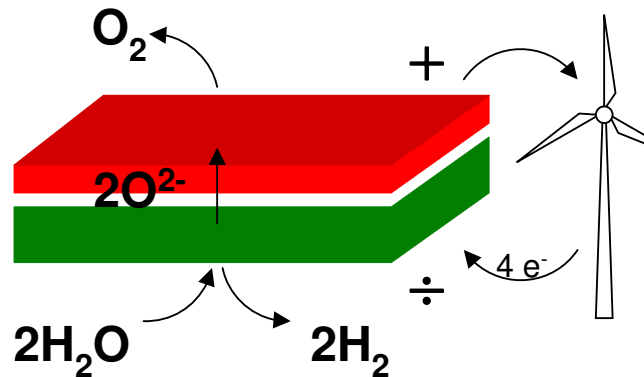

Consuming water and electricity  
Producing hydrogen  
Electrolysis of  $\text{CO}_2 + \text{H}_2\text{O}$  to  
synthesis-gas ( $\text{CO} + \text{H}_2$ )

## Morgenkaffen kogt på strøm fra vindmøller

27. okt. 2006 10.54 Indland

Halvdelen af landets husholdninger har i dag kunnet lave morgenkaffe med strøm fra vindmøller. Efterårets første alvorlige blæsevejr er nemlig guldgrube for den alternative energi.

Kl. 9 i dag kunne stømmen fra møllerne dække cirka halvdelen af det samlede årsforbrug. I 2006 leverer møller ellers kun strøm til 20 procent af forbruget.

Med en vindhastighed op omkring 20 m/s i det vestlige Jylland, hvor mange vindmøller er placeret, er elproduktionen fra vindmøller tæt på det maksimalt mulige.

Kommer vindhastigheden op omkring 25 m/s, stopper vindmøllerne derimod.

### Gratis el i nat

I nat betød elproduktion fra vindmøllerne, at udbuddet af el på den nordiske elbørs var så stort, at elspotprisen i både Øst- og Vestdanmark var nul i timerne mellem kl. 23 og kl. 5.

Vindmøllerne producerede strøm nok til at dække 80 procent af det samlede elforbrug i Danmark.

Landets kraftværker måtte endda skruer ned for produktionen, fordi der ikke var plads til mere strøm på de elektriske forbindelser til udlandet.

# Principle for SOECs

## Solid Oxide Electrolysis Cells

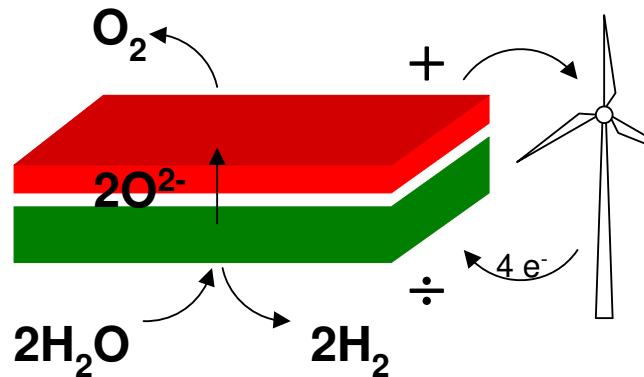

Consuming water and electricity  
Producing hydrogen  
Electrolysis of  $\text{CO}_2 + \text{H}_2\text{O}$  to  
synthesis-gas ( $\text{CO} + \text{H}_2$ )

Ingeniøren  
ing.dk

## Danmarks første brintanlæg åbner på mandag

Nakskov får landets første anlæg, der ved hjælp af strøm fra vindmøller spalter vand til brint og ilt. Samtidig er Lolland vært for en international energikonference.

Af [Thomas Lemke](#) | onsdag 16.05.2007 kl. 11:43

På mandag, den 21. maj, klippes den røde snor, og Danmarks første fuldskala brintanlæg begynder at producere brint.



På mandag begynder elektrolyseanlægget i Nakskov produktionen af brint. [Klik for større foto](#)

Anlægget, der står i Nakskov, skal omdanne strøm fra vindmøller til brint og dermed være med til at løse problemet med at lagre energi fra vindmøller. I første omgang fungerer det som demonstrationsanlæg, men om et par år er det meningen, at det skal indgå i et større anlæg og forsyne Vestenskov på Vestlolland med brint.

Når det blæser kraftigt, producerer vindmøllerne på Lolland mere strøm, end markedet kan aftage, og prisen dykker til næsten ingenting. Derfor er der store fordele i at anvende overskudsstrømmen til at fremstille brint, argumenterer initiativtagerne, selv om meget af energien fra vindmøllestrømmen går tabt under processen.

## Advantages of SOECs

	SOEC	Alkaline	PEM
Reactants and products	$\text{H}_2\text{O} \rightarrow \text{H}_2$ $\text{CO}_2 \rightarrow \text{CO}$	$\text{H}_2\text{O} \rightarrow \text{H}_2$	$\text{H}_2\text{O} \rightarrow \text{H}_2$
Electrolyte	Ceramic	KOH or NaOH	Polymer
Electrodes	Nickel, ceramics	Nickel	Platinum
Temperature	850 °C	80 °C	80 °C

# Advantages of SOECs

Thermodynamics for water electrolysis

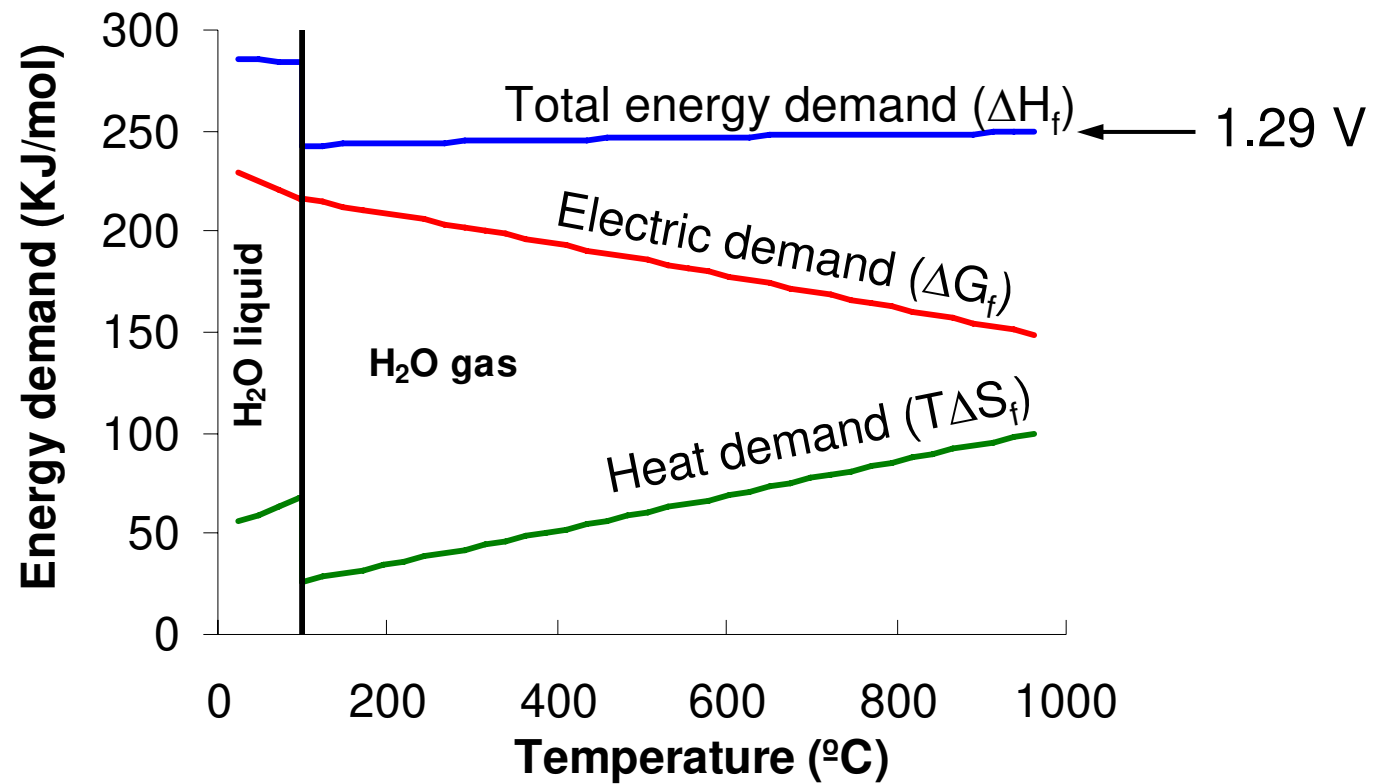

**Thermodynamics is optimal case ... Real life ?**

**Solid Oxide Electrolysis Cells**

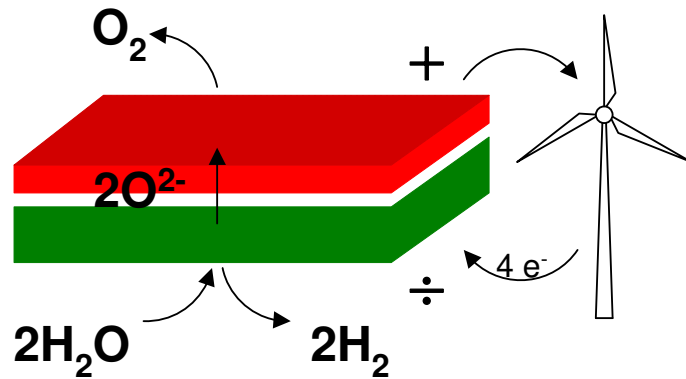

**Solid Oxide Fuel Cells**

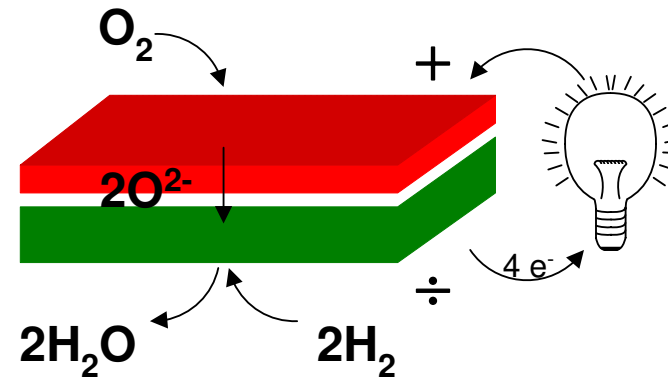

# Thermodynamics is optimal case ... Real life ?

## Solid Oxide Electrolysis Cells

**World record  
-3.6 A/cm<sup>2</sup> at 1.48 V**

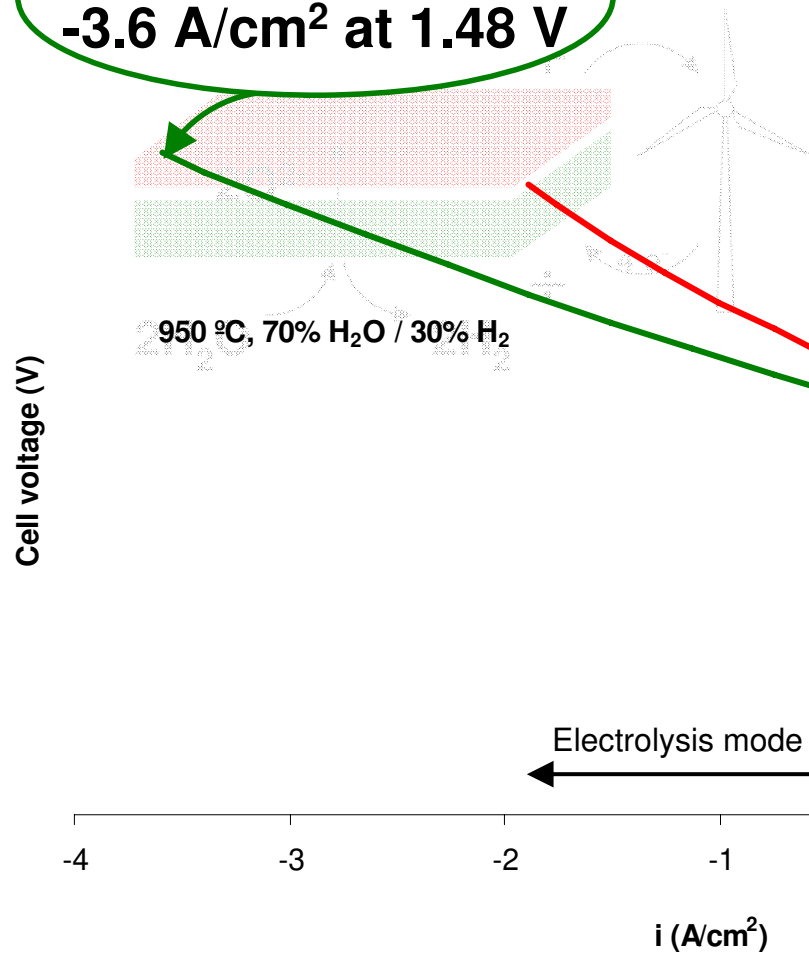

## Solid Oxide Fuel Cells

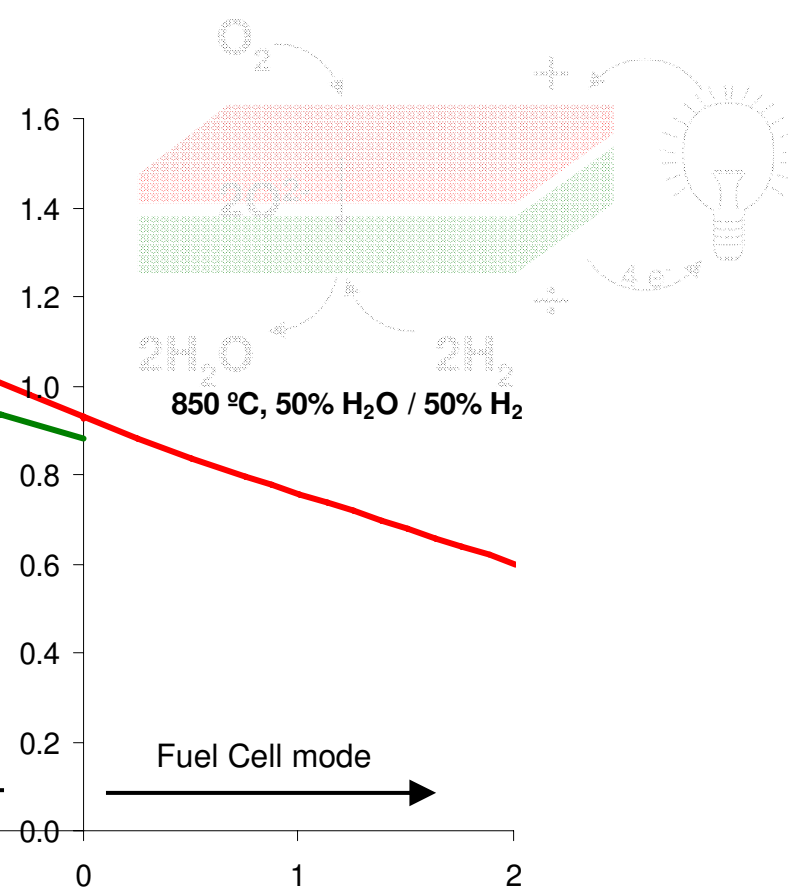

# Thermodynamics is optimal case ... Real life ?

## Solid Oxide Electrolysis Cells

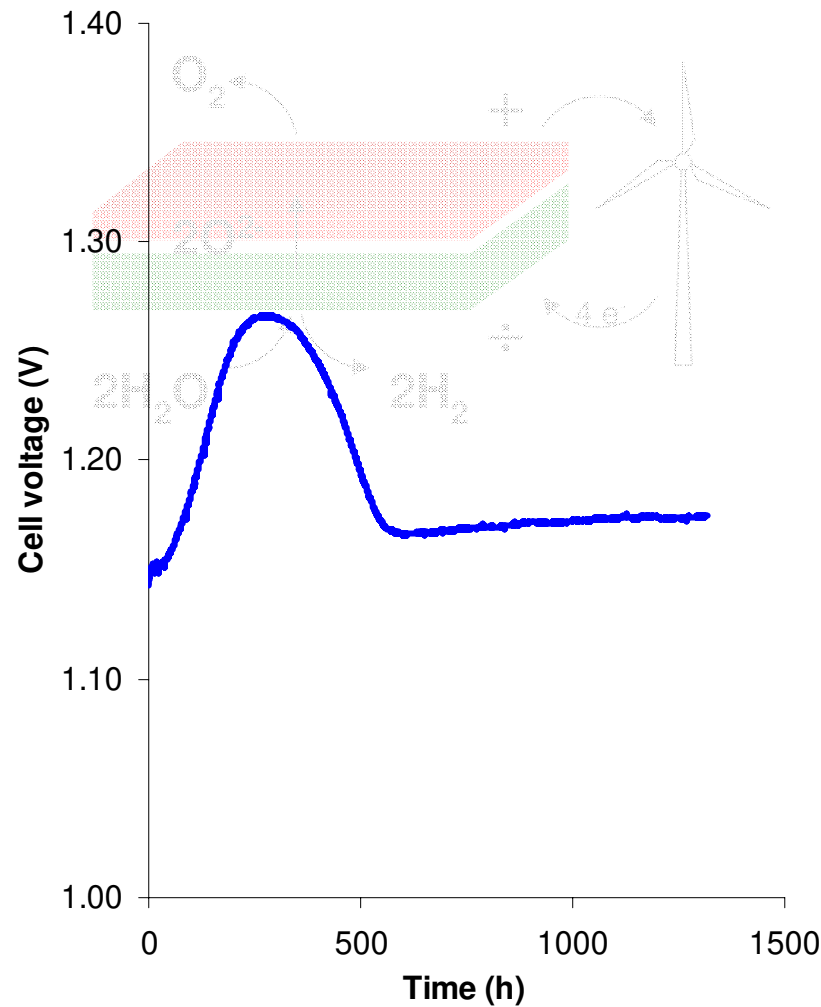

## Solid Oxide Fuel Cells

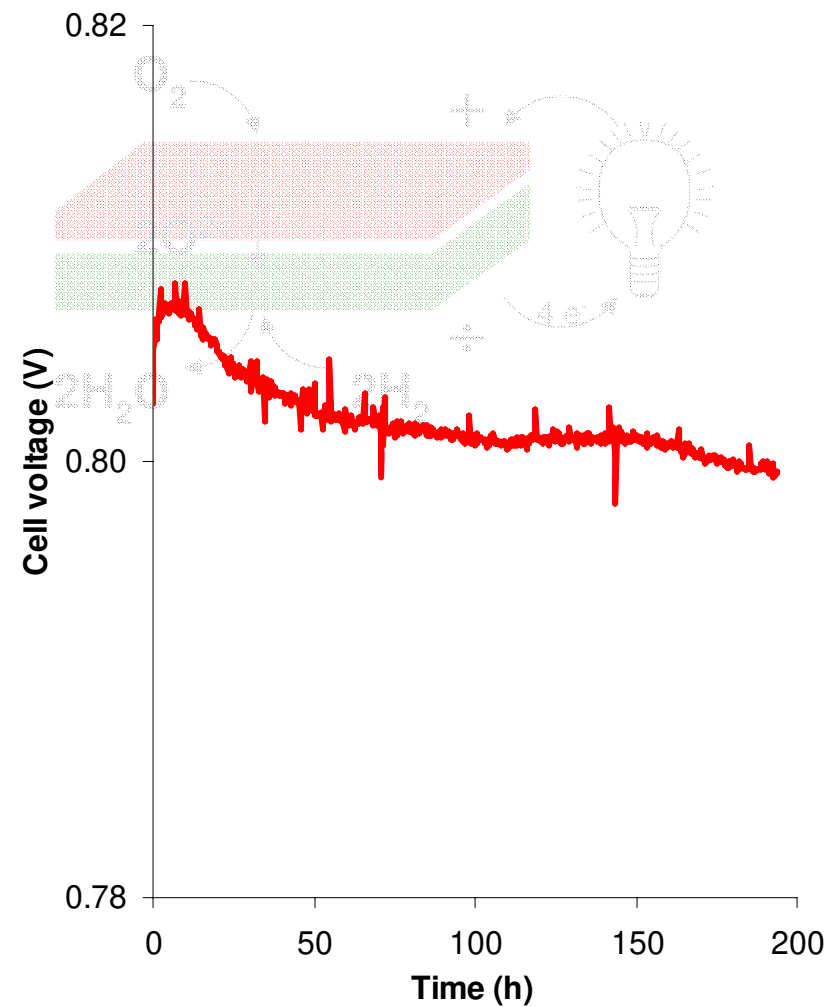



# SOEC Durability

## SEM micrograph of hydrogen electrode after electrolysis

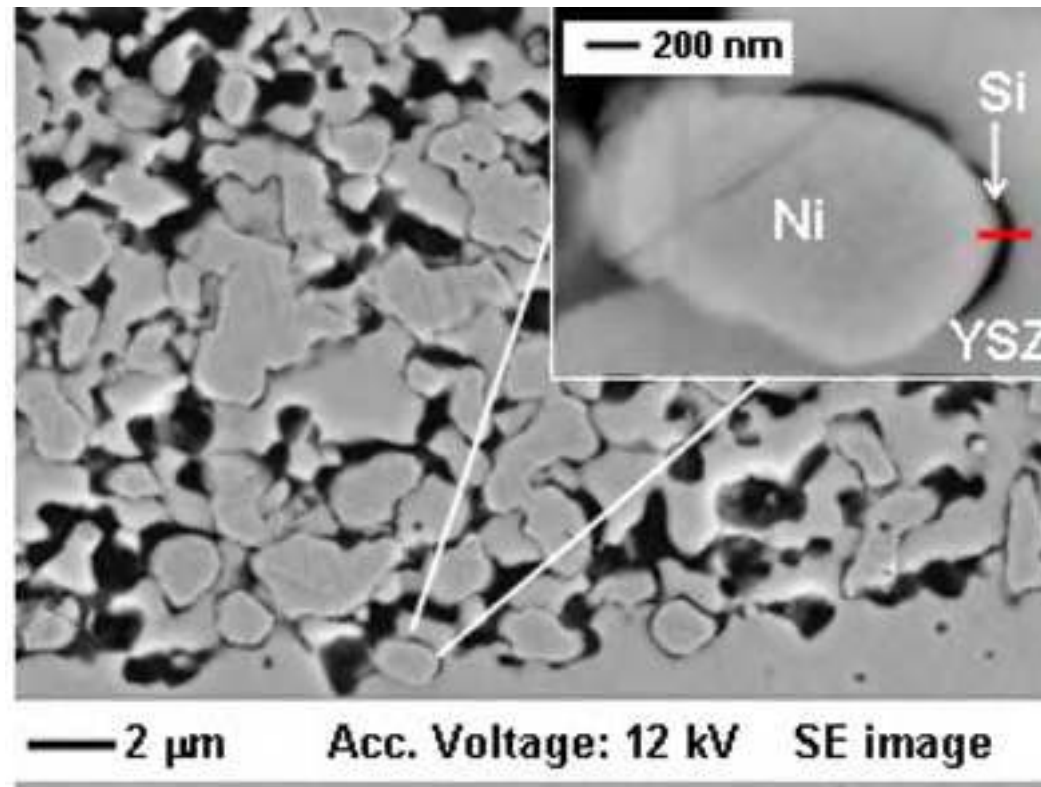

Post examination after electrolysis at 850°C, 70% H<sub>2</sub>O, -1 A/cm<sup>2</sup> for 353 h and -0.5 A/cm<sup>2</sup> for 227 h

# SOEC Durability

Electrolysis cell	Fuel cell [1]
-0.5 A/cm <sup>2</sup> at 850°C	1.0 A/cm <sup>2</sup> at 850°C
~2%/1000 h (1316 h test)	Below 1%/1000 h (1500 h test)

-1.0 A/cm <sup>2</sup> at 950°C	1.0 A/cm <sup>2</sup> at 950°C
~30%/1000 h (620 h test)	Below 1%/1000 h (1500 h)

# Economy estimation for hydrogen production

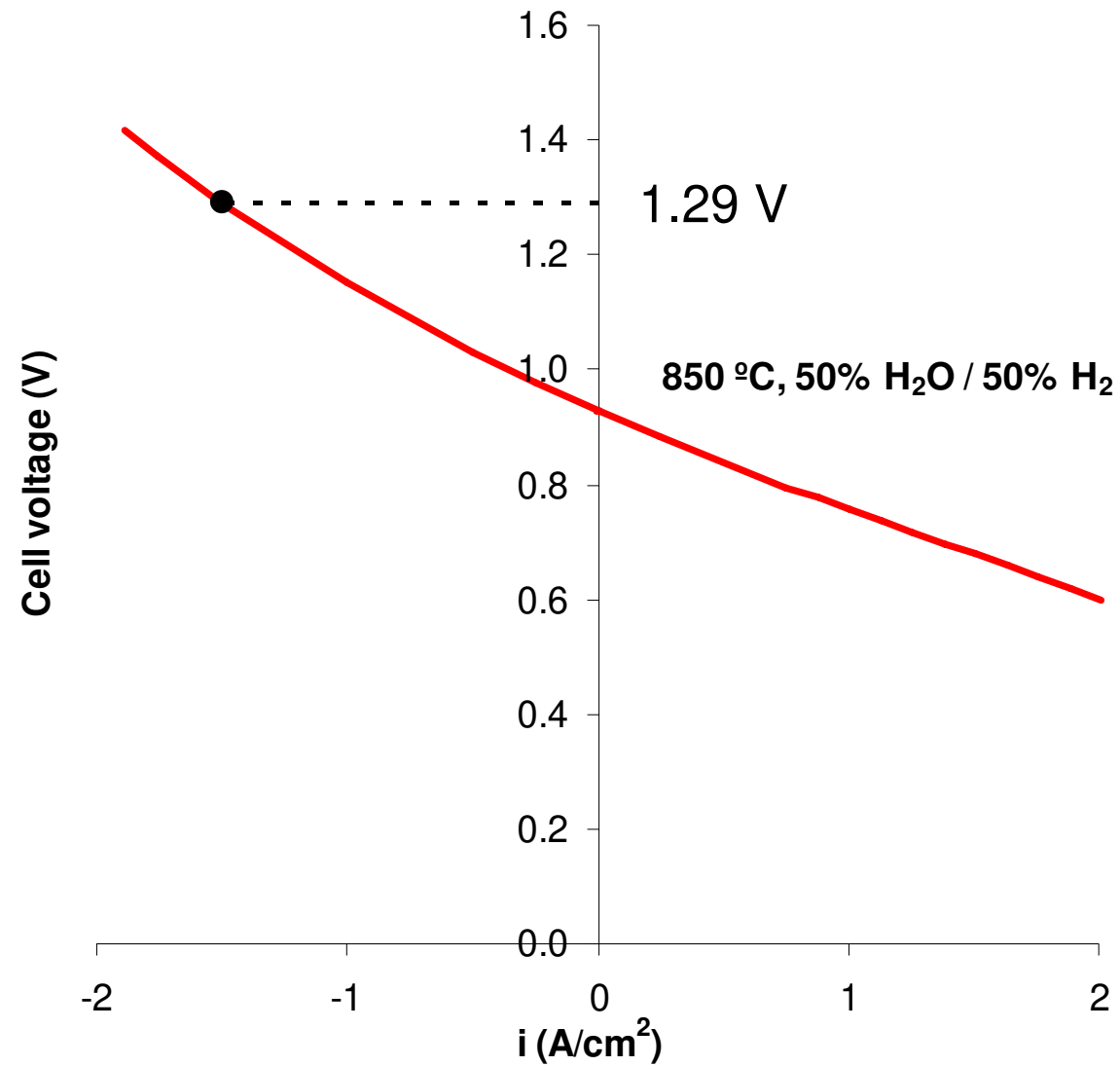

## Economy estimation for hydrogen production

---

<b>Cell voltage</b>	<b>1.29 V (thermo neutral potential)</b>
<b>Electricity price</b>	<b>1.3 US¢/kWh</b>
Heat price	0.3 US¢/kWh
<b>Investment</b>	<b>4000 US\$/m<sup>2</sup> cell area</b>
Demineralised Water	2.3 US\$/m <sup>3</sup>
Cell temperature	850 ° C
Heat reservoir temperature	110 °C
Pressure	1 atm
<b>Life time</b>	<b>10 years</b>
Operating activity	50%
Interest rate	5%
Energy loss in heat exchanger	5%
H <sub>2</sub> O inlet concentration	95% (5% H <sub>2</sub> )
H <sub>2</sub> O outlet concentration	5% (95% H <sub>2</sub> )

---

# Economy estimation for hydrogen production

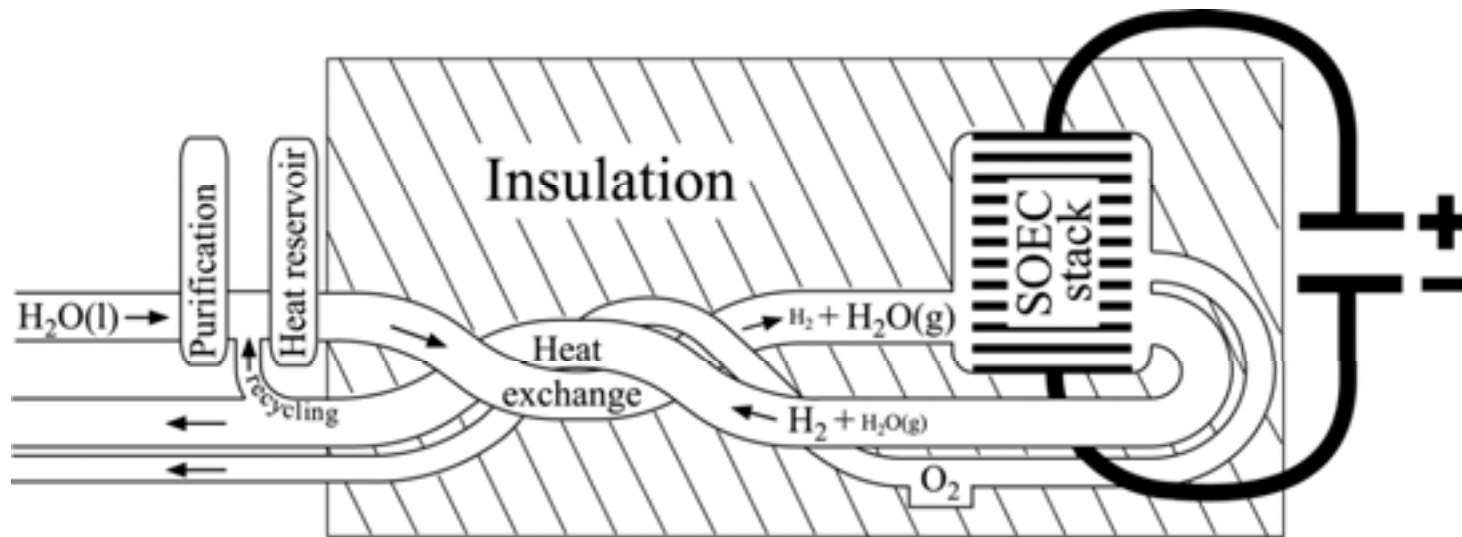

# Economy estimation for hydrogen production

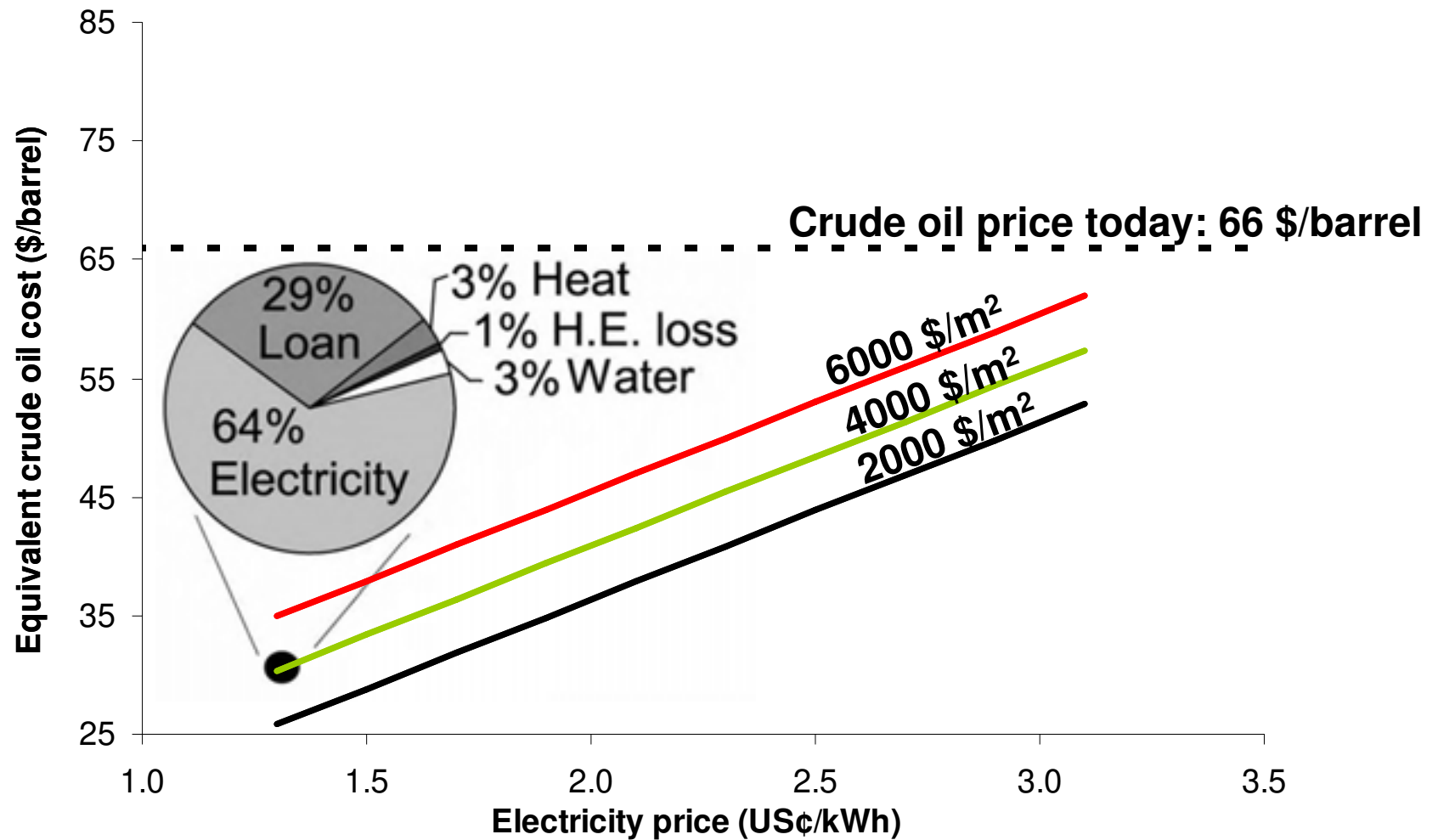

# Economy estimation for hydrogen production

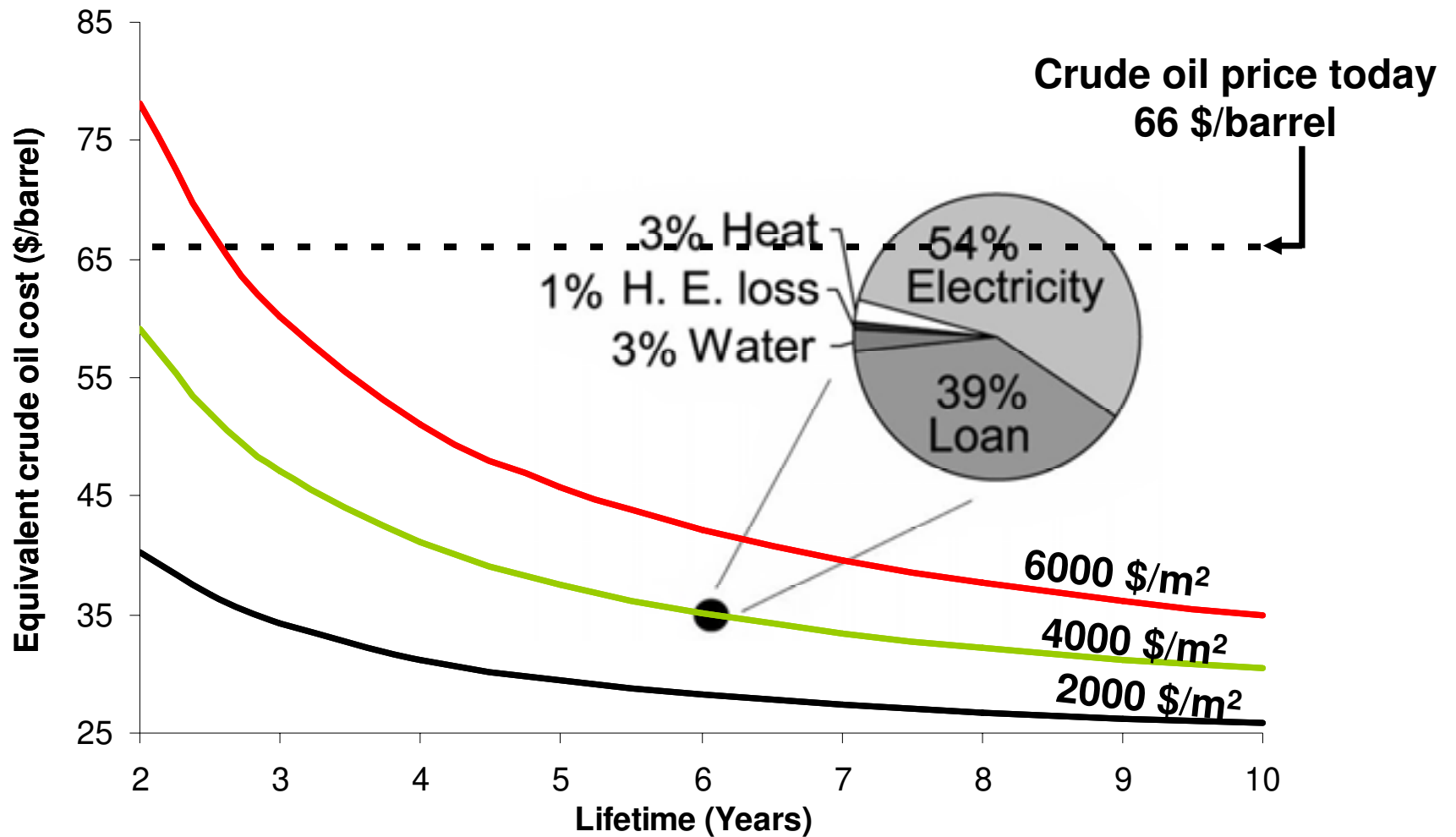

## Conclusion (hydrogen production)

- Excellent initial electrolysis performance
- Main passivation problem on hydrogen electrode
  - Significant amount of silica impurities
- Long-term durability needs to be improved
- Low hydrogen production price by electrolysis



# Production of synthetic fuel

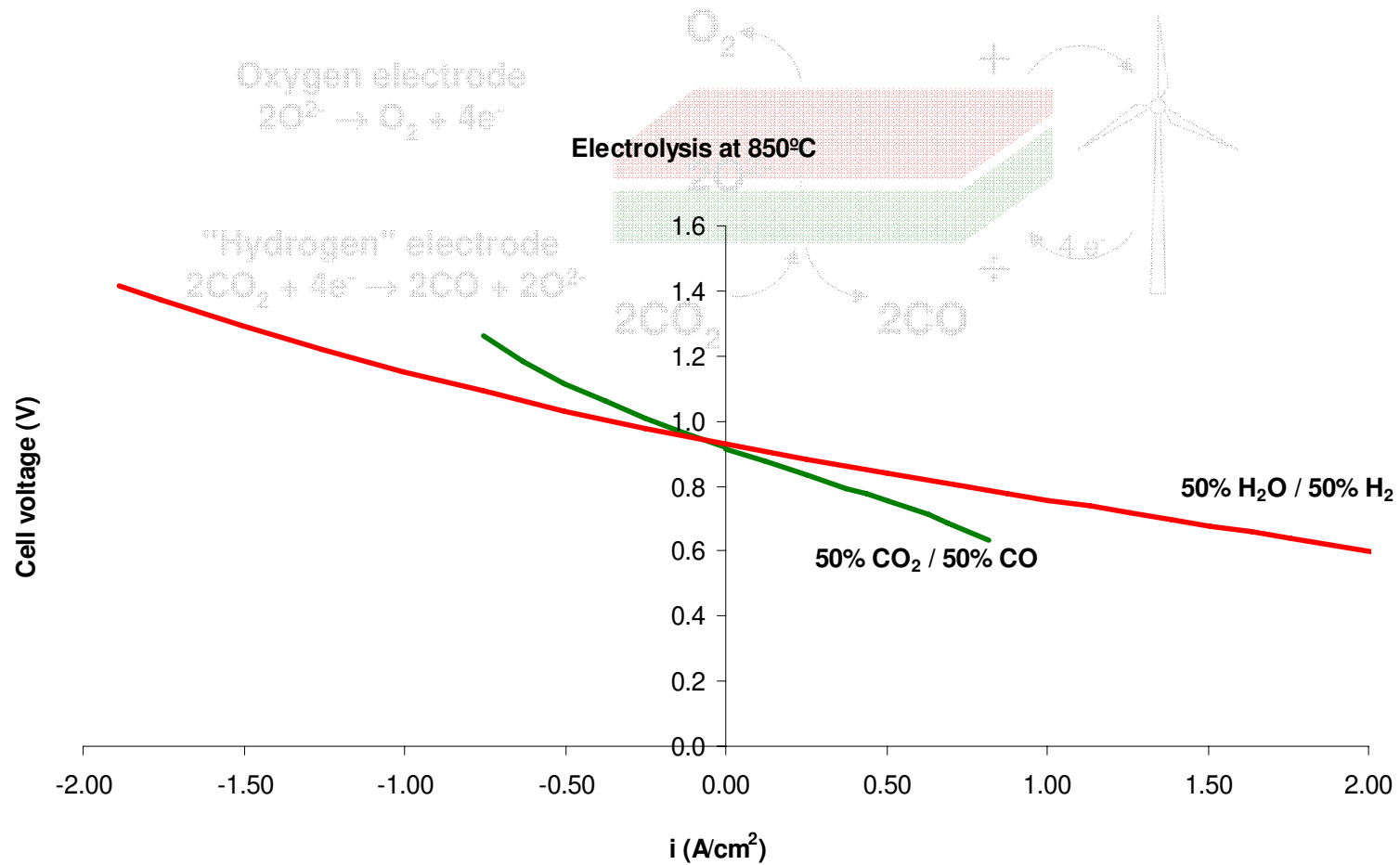

# Production of synthetic fuel

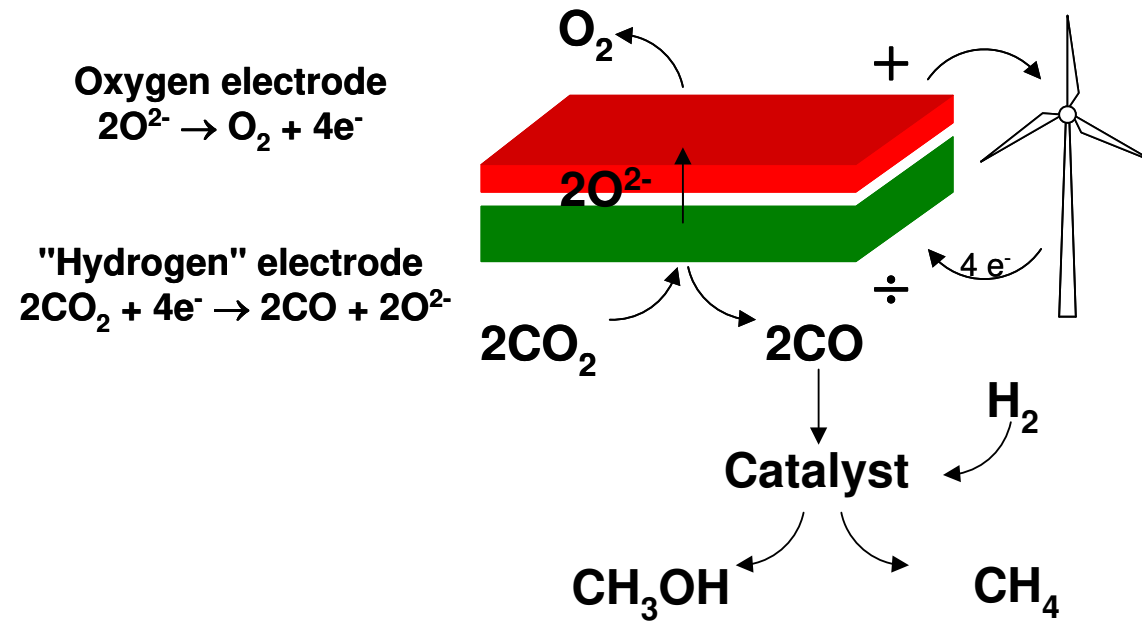

# Production of synthetic fuel

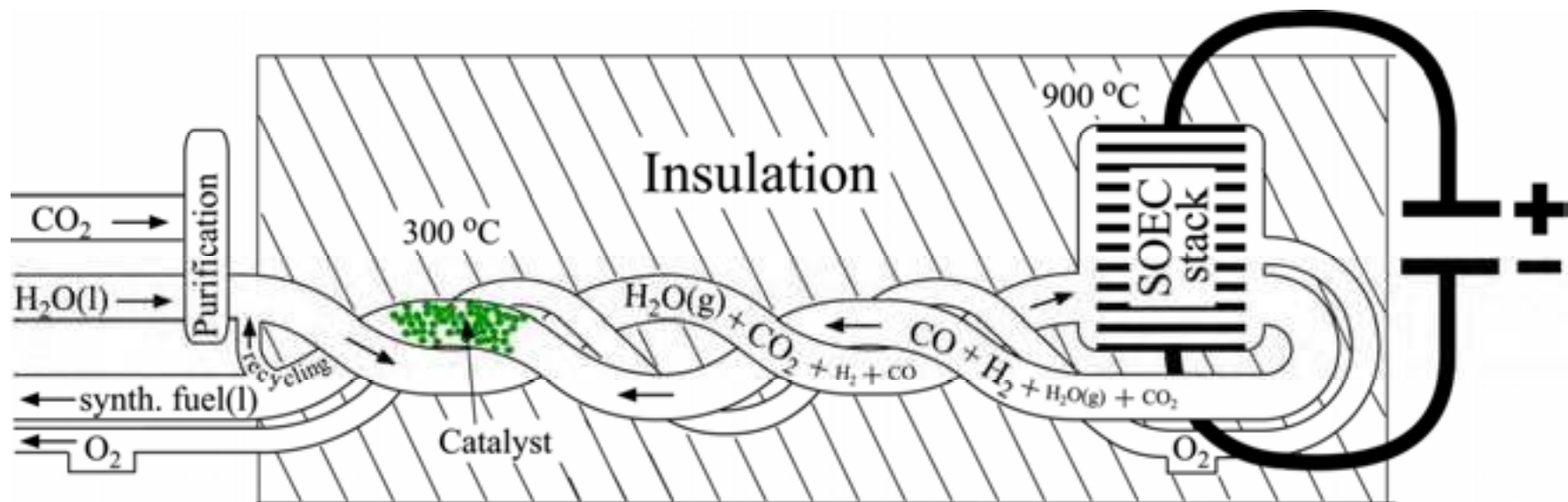
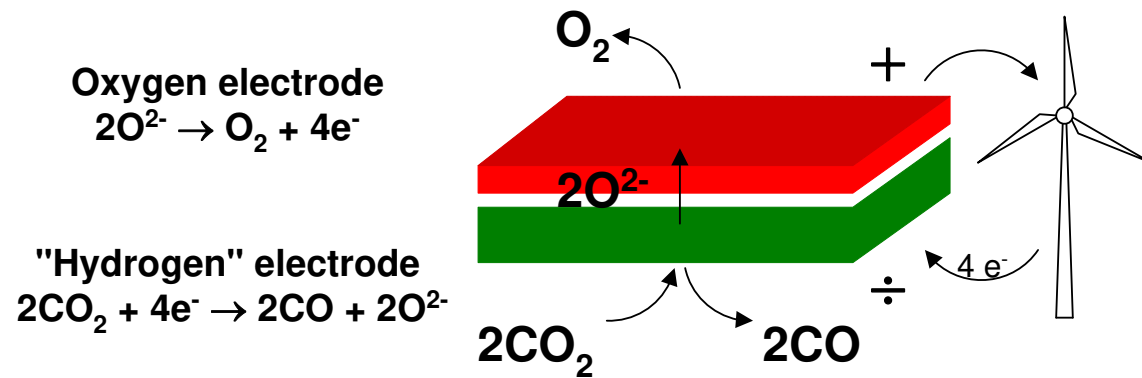

# Production of synthetic fuel

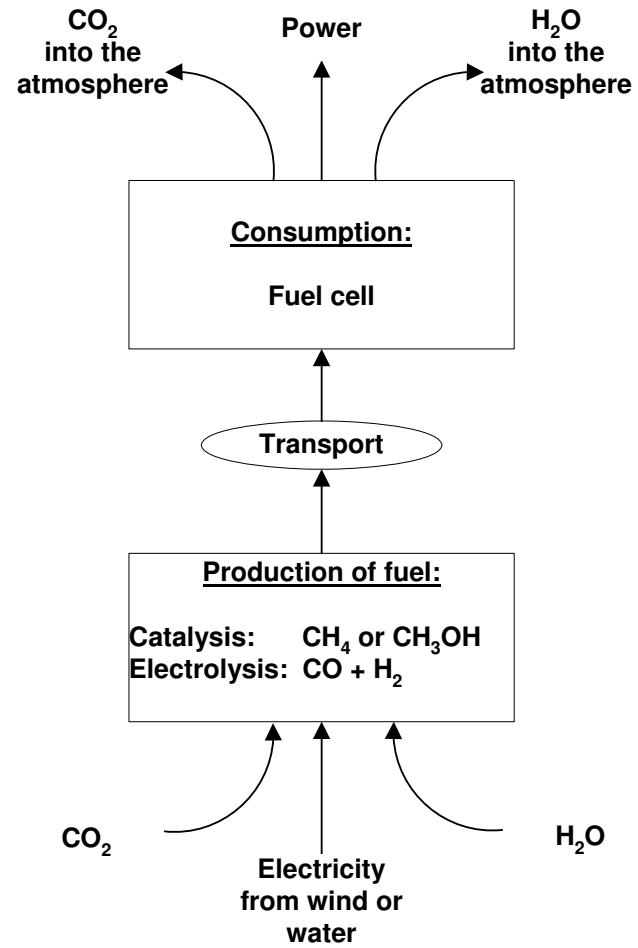

# Production of synthetic fuel

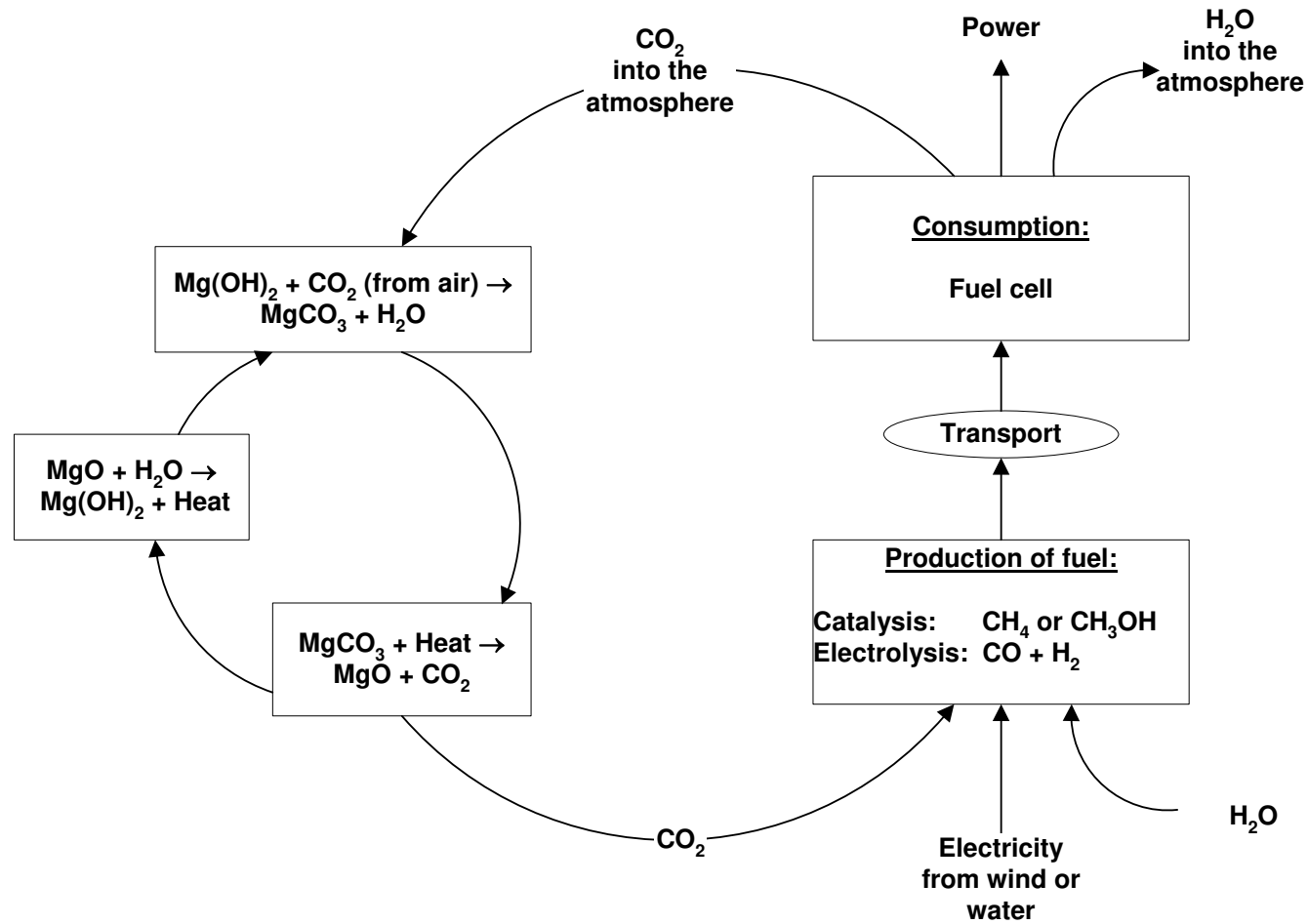

## Conclusion & Outlook

- **Excellent initial electrolysis performance**
- Main passivation problem on hydrogen electrode
  - Significant amount of silica impurities
- Long-term durability needs to be improved
- **Low hydrogen production price by electrolysis**
- **Synthetic fuel for the future**

# Solid Oxide Electrolysis for Fuel Production

Sune D. Ebbesen, Anne Hauch, Søren H. Jensen, and Mogens Mogensen

***Thank you***

Fuel Cell and Solid State Chemistry Department  
Risø National Laboratory, Technical University of Denmark  
DK-4000 Roskilde, Denmark

[www.risoe.dk](http://www.risoe.dk)

[Sune.Ebbesen@risoe.dk](mailto:Sune.Ebbesen@risoe.dk)

Risø International Energy Conference, 23<sup>rd</sup> May 2007

# Extra slides



# Crude oil price

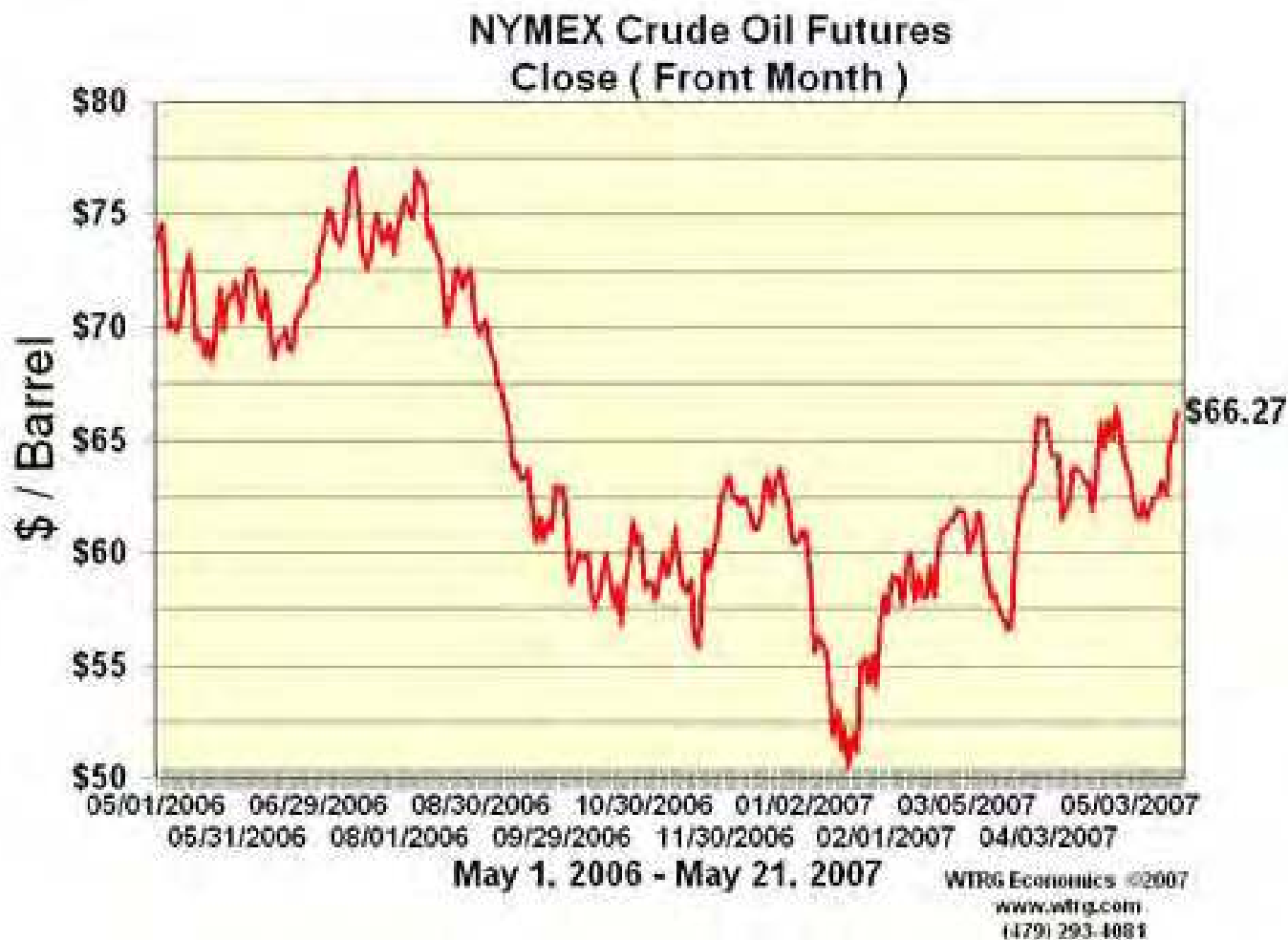

# Danmarks første brintanlæg

## Danmarks første brintanlæg åbner på mandag

Nakskov får landets første anlæg, der ved hjælp af strøm fra vindmøller spalter vand til brint og ilt. Samtidig er Lolland vært for en international energikonference.

Af Thomas Lemke | onsdag 16.05.2007 kl. 11:43

På mandag, den 21. maj, klippes den røde snor, og Danmarks første fuldskala brintanlæg begynder at producere brint.

Anlægget, der står i Nakskov, skal omdanne strøm fra vindmøller til brint og dermed være med til at løse problemet med at lagre energi fra vindmøller. I første omgang fungerer det som demonstrationsanlæg, men om et par år er det meningen, at det skal indgå i et større anlæg og forsyne Vestenskov på Vestlolland med brint.



På mandag begynder elektrolyseanlægget i Nakskov produktionen af brint. Klik for [store foto](#)

Når det blæser kraftigt, producerer vindmøllerne på Lolland mere strøm, end markedet kan aftage, og prisen dykker til næsten ingenting. Derfor er der store fordele i at anvende overskudsstrømmen til at fremstille brint, argumenterer initiativtagerne, selv om meget af energien fra vindmøllestrømmen går tabt under processen.

Brinten kan nemlig lagres i tanke og senere bruges i elværker, som brændstof i brintbiler eller sendes direkte ud til forbrugerne via rørfedninger.

Brinten produceres ved hjælp af elektrolyse, hvor almindeligt vand spaltes til brint og ilt ved hjælp af strøm. Ved at bruge overskudsstrøm fra vindmøller bliver brinten således CO2-neutral energi, og samtidig er det en brugbar måde at lagre strøm fra vindmøller på.

Åbningen af brintanlægget i Nakskov klokken cirka 17.15 på Nakskov Genbrugsstation, Miljøvej 14, Nakskov. Arrangementet er åbent for alle interesserede.

# Morgenkaffe kogt på strøm fra vindmøller

## Morgenkaffen kogt på strøm fra vindmøller

■ 27. okt. 2006 10.54 Indland

Halvdelen af landets husholdninger har i dag kunnet lave morgenkaffe med strøm fra en dansk vindmølle. Efterårets første alvorlige blæsevejr er nemlig guldgrube for den alternative energiproduktion.

Kl. 9 i dag kunne stømmen fra møllerne dække cirka halvdelen af det samlede danske elforbrug. På årsplan leverer møller ellers kun strøm til 20 procent af forbruget.

Med en vindhastighed op omkring 20 m/s i det vestlige Jylland, hvor mange af Danmarks vindmøller er placeret, er elproduktionen fra vindmøller tæt på det maksimalt mulige.

Kommer vindhastigheden op omkring 25 m/s, stopper vindmøllerne derimod for at beskytte sig selv.

### Gratis el i nat

I nat betød elproduktion fra vindmøllerne, at udbuddet af el på den nordiske elbørs, Nord Pool Spot, i går var så stort, at elspotprisen i både Øst- og Vestdanmark var nul i timerne mellem kl. 1 og kl. 5 i nat.

Vindmøllerne producerede strøm nok til at dække 80 procent af det samlede forbrug klokken 4 i nat.

Landets kraftværker måtte endda skrue ned for produktionen, fordi der ikke var plads til yderligere eksport på de elektriske forbindelser til udlandet.

---



# **Use of Alternative Fuels in Solid Oxide Fuel Cells**

**Anke Hagen**

Fuel Cells and Solid State Chemistry Department  
Risø National Laboratory  
Technical University of Denmark

## Outline

- **Background**
  - **Conventional – Alternative fuels**
  - **Solid Oxide Fuel cells – SOFCs**
- **SOFC Fuelled with alternative feed stocks**
  - **Performance/stability**
  - **Effect of impurities**
- **Summary - Outlook**

# Background - Conventional vs. Alternative Fuels

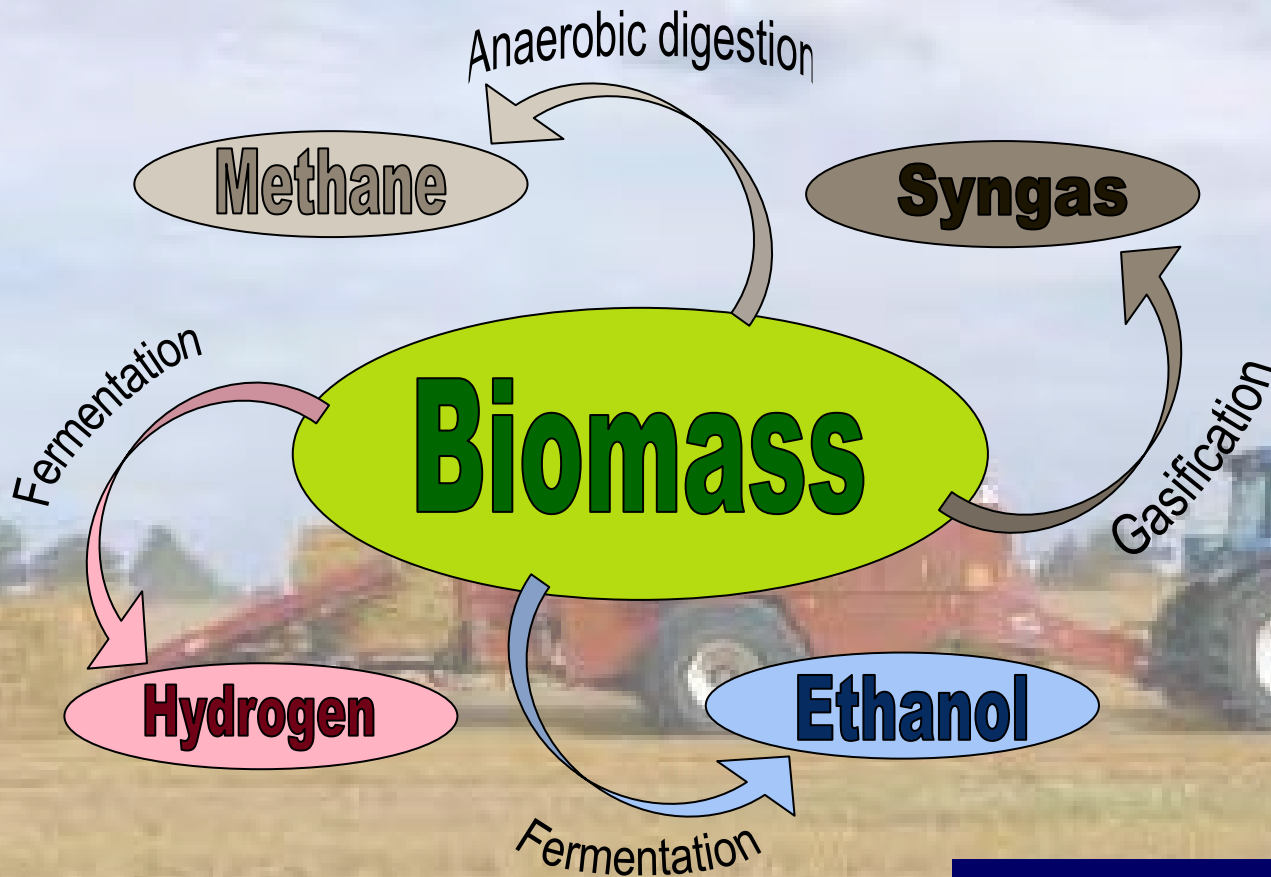

**Fuels for SOFCs**

## Background – Motivation for the Use of Alternative Fuels

- Reserves of conventional fuel sources (natural oil and gas) limited
- Economic reasons (increase of crude oil price)
- Dependable supply and availability
- Local, de-central solutions
- Environmental restrictions (CO<sub>2</sub> emissions, stringent pollution limits)

## Solid Oxide Fuel Cells – SOFCs – Vision

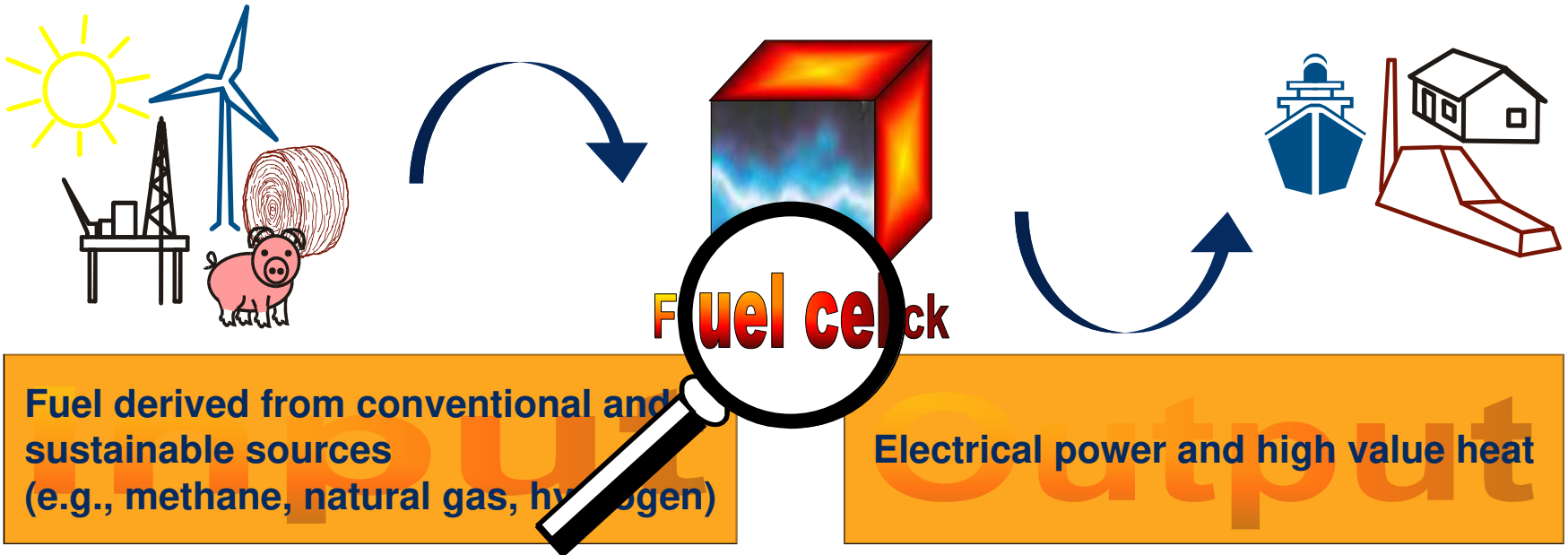

- Higher efficiency than conventional power generation systems
- Reduction of emissions and pollution (NO<sub>x</sub>, CO<sub>2</sub>, noise)
- Potential for CO<sub>2</sub> sequestration
- Modular concept (from kW to MW)

**Combination of two (potentially) environmentally benign and efficient technologies – fuels derived from biomass and fuel cells to contribute to a sustainable energy supply system**



# Solid Oxide Fuel Cells – SOFCs - Principle

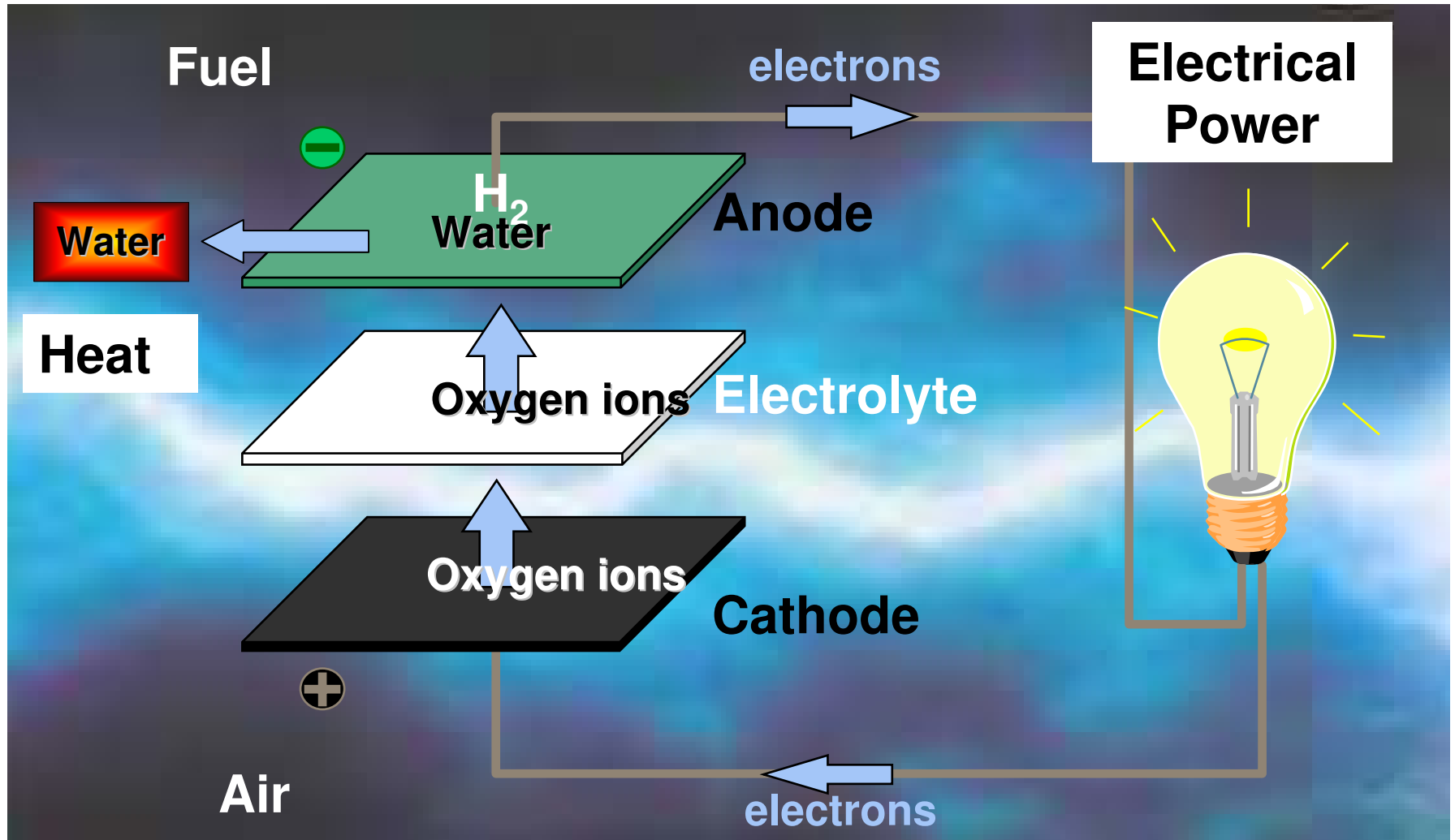

# Solid Oxide Fuel Cells – SOFCs - Testing

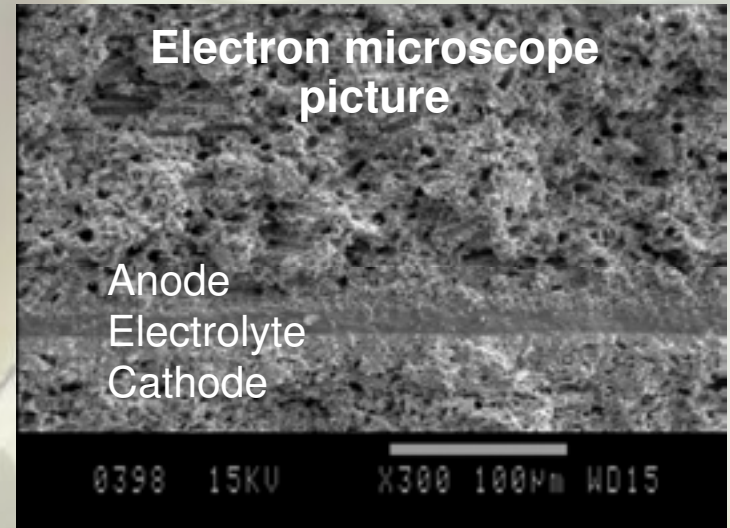
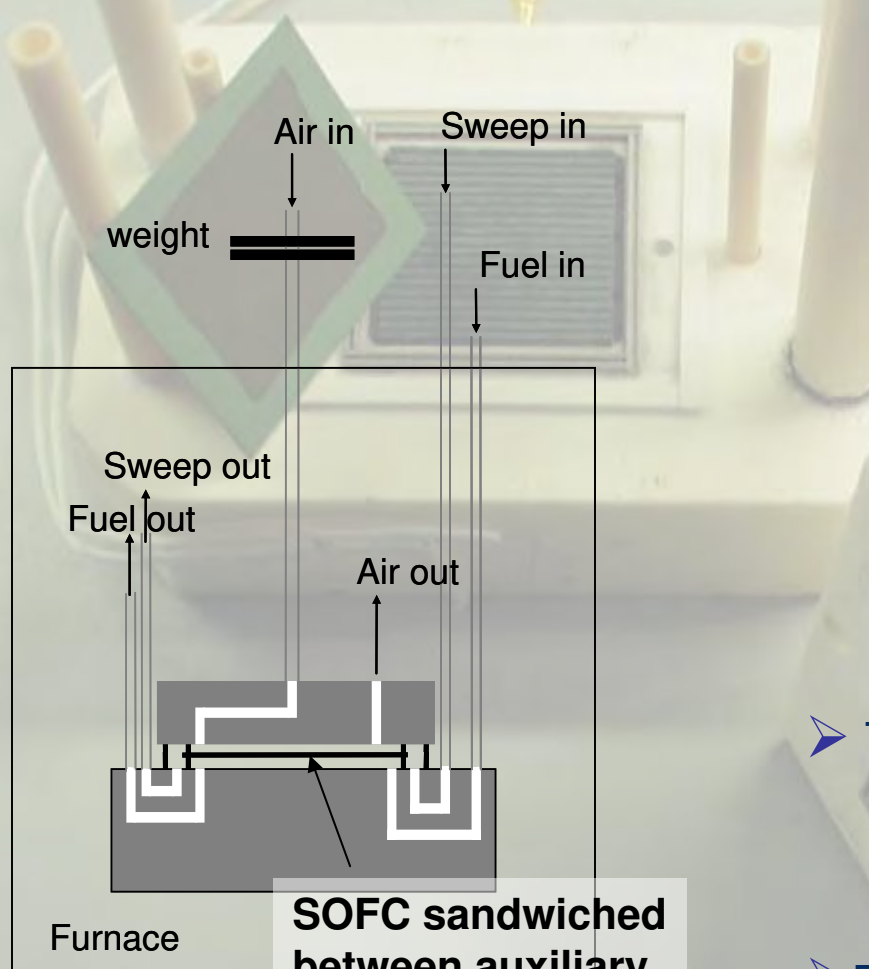

- Test of performance and long-term durability under technologically relevant conditions
- Effect of impurities in the fuel

# General Considerations about Carbon Containing Fuels

- CO and H<sub>2</sub> are direct fuels for SOFCs



- Carbon containing fuels are to be converted to CO and H<sub>2</sub>, for example by partial oxidation or reforming (see equations):

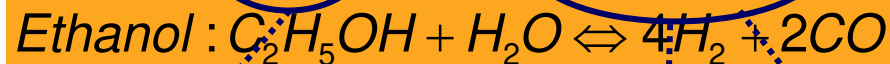

- The SOFC anode acts as catalyst for reforming (see gas analysis):

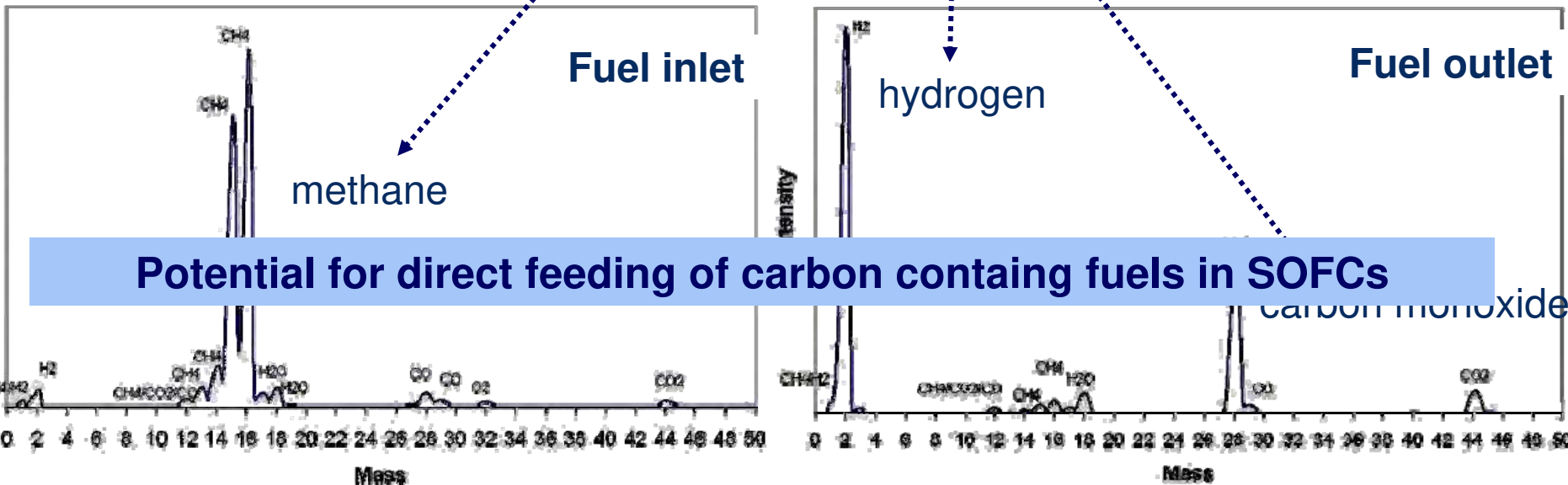

# SOFC Anode as Catalytic Converter: Methane

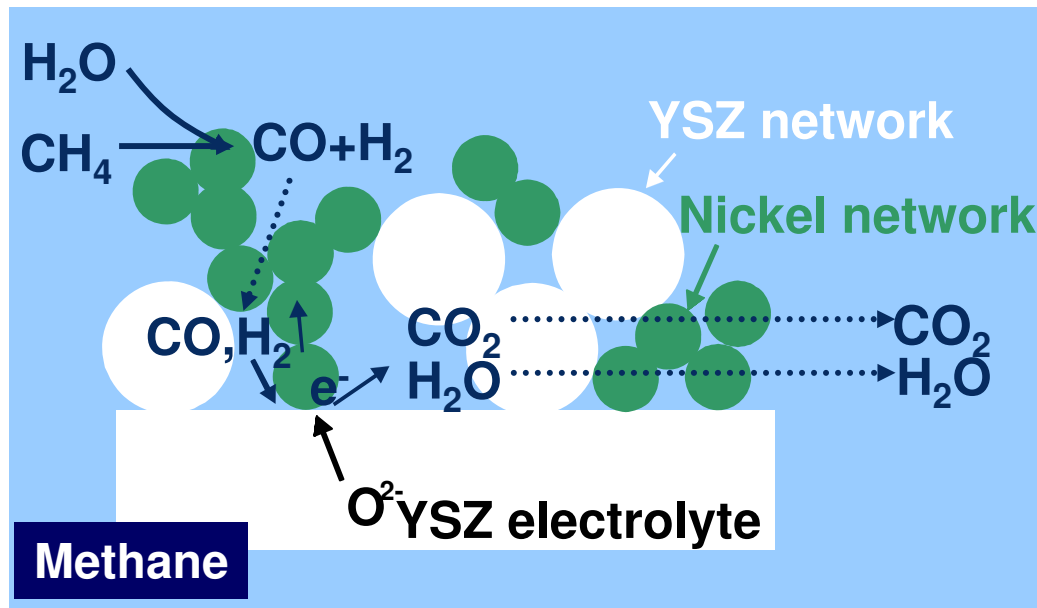

## Alternative Fuels - Ammonia



- Becomes liquid at 8 bar: storage and transport
- Comparable power density by weight and volume as carbon fuels such as petrol
- Does not release  $\text{CO}_2$  under SOFC-process
- Second largest synthetic product in the world (fertilizer, chemicals)
- More than 90% of the overall consumption manufactured by Haber-Bosch-Synthesis ( $\text{H}_2 + \text{N}_2$  on iron-containing catalyst at elevated temperatures (350 – 550 °C) and pressures above 100 bar)

# SOFC Anode as Catalytic Converter: Ammonia

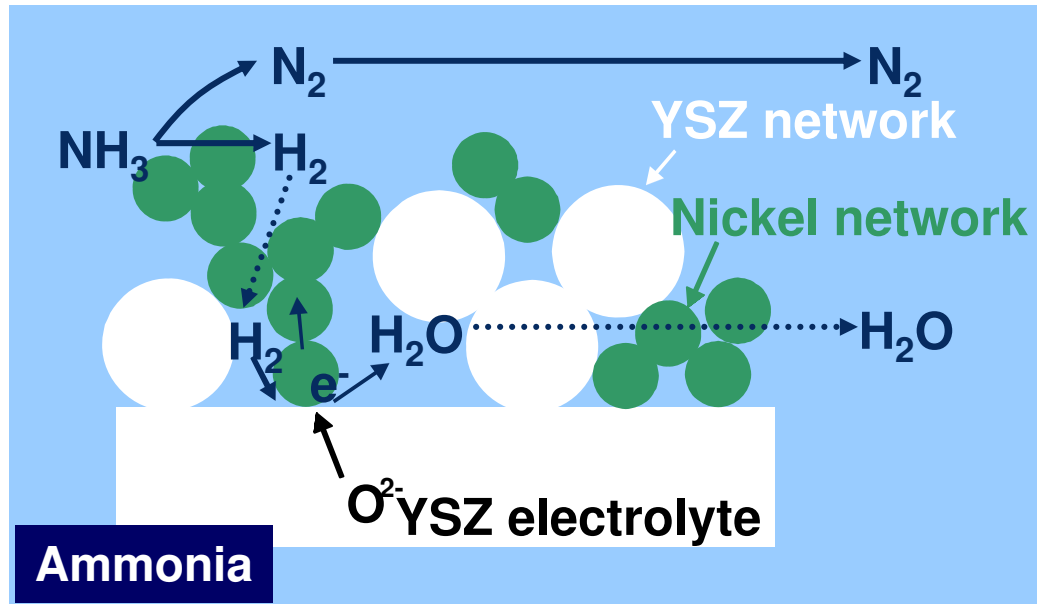

# Long-term performance of SOFCs

5 x 5 cm<sup>2</sup> SOFC at 850 °C, 1 A/cm<sup>2</sup> current density, ~75-80% fuel utilization

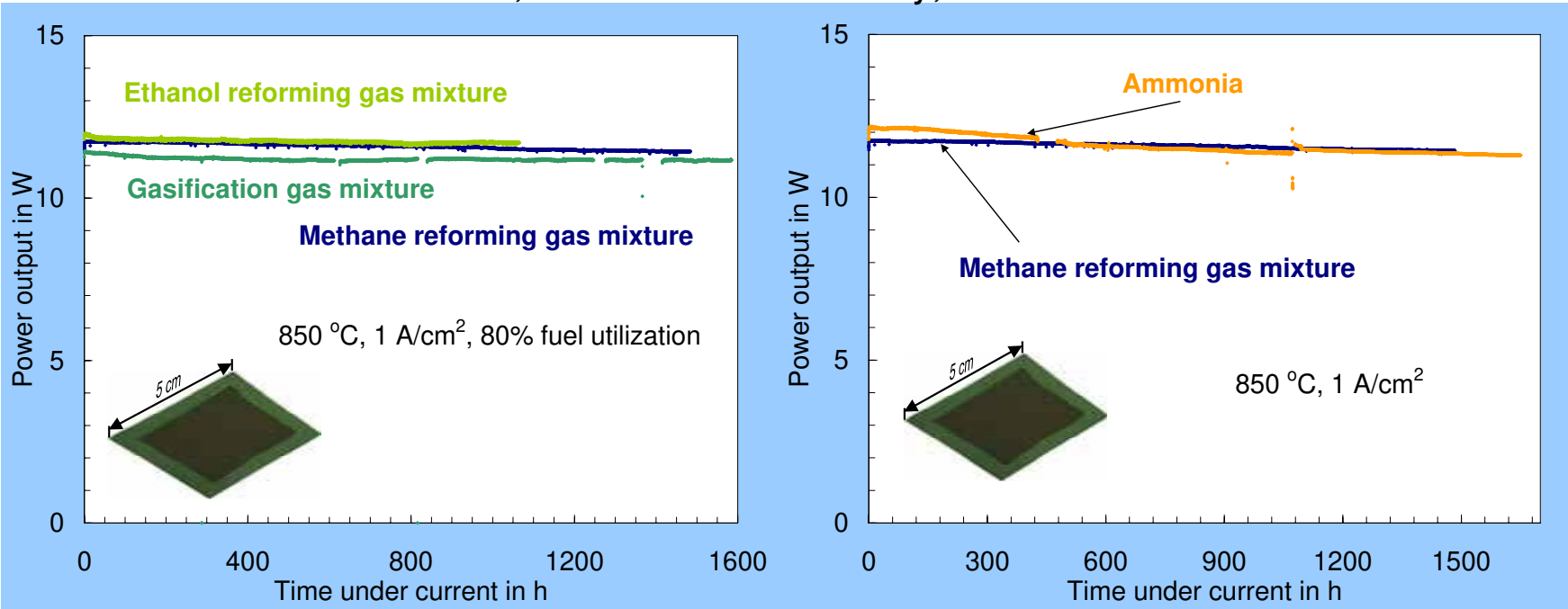

Methane reforming gas mixture: steam to carbon ratio of 2  
 Gasification gas mixture: wood derived  
 Ethanol reforming mixture: ethanol/water ratio of 1/1.5

Methane reforming gas mixture: steam to carbon ratio of 2  
 Ammonia: 100%

- Technologically relevant conditions
  - Large power output
  - Stable performance over 1500 hours (and beyond)

# Biogas – Composition – Minor constituents - Impurities

Saturated with water

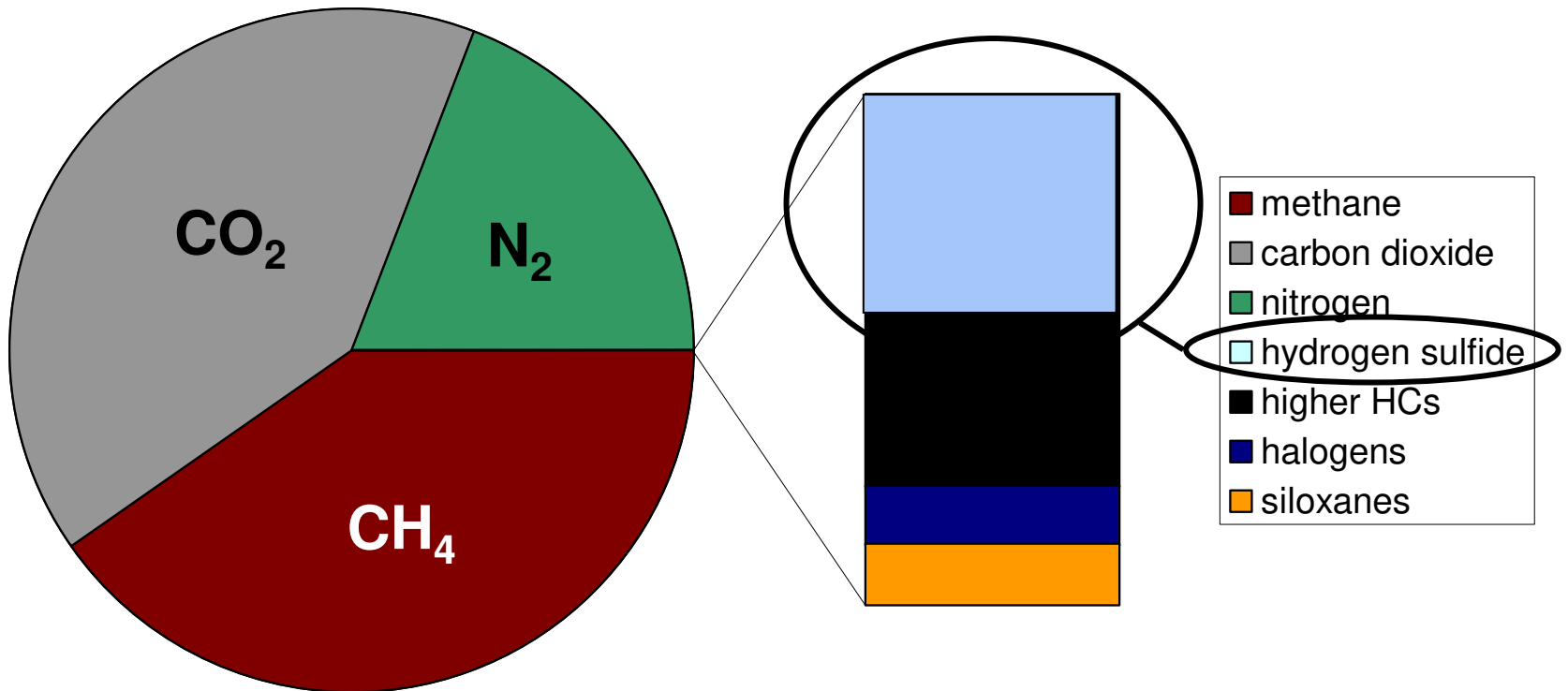

Landfill gas, De Mes et al. 2003



# Effect of H<sub>2</sub>S impurities on performance of SOFC

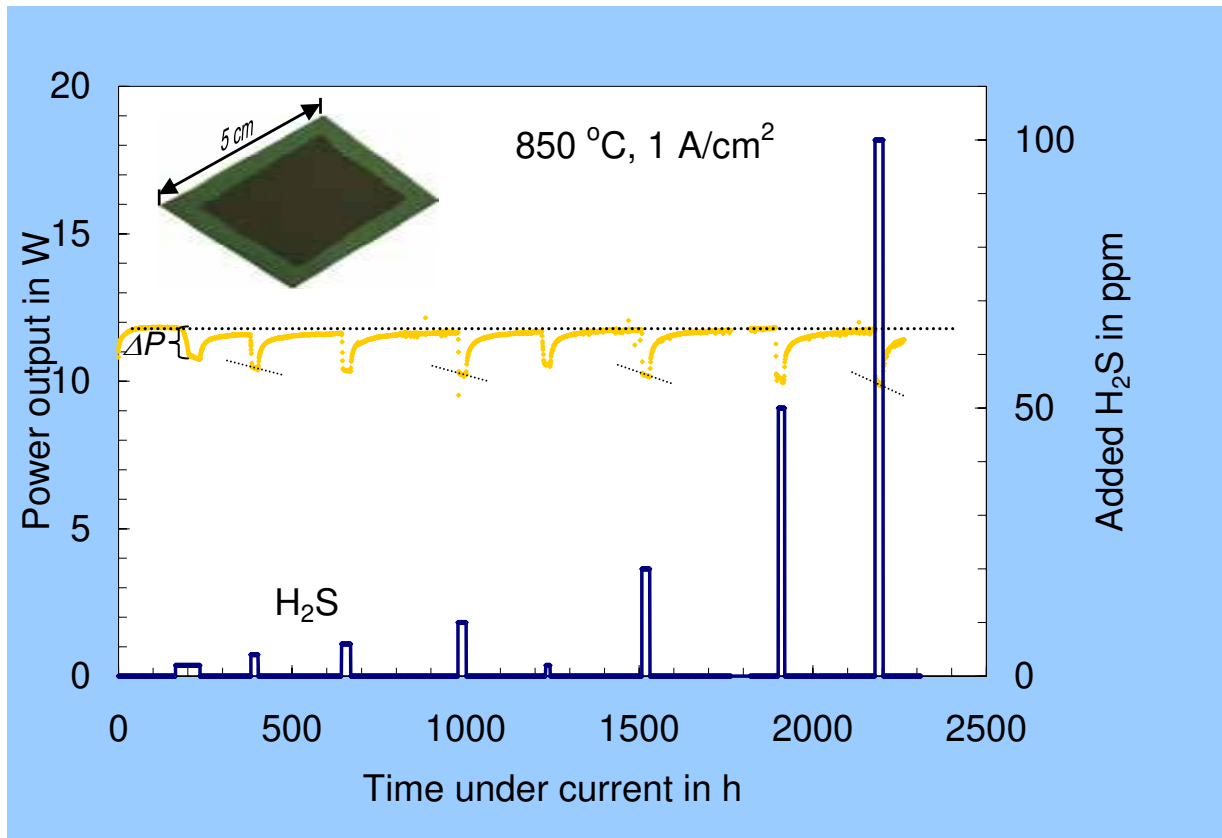

Power output under a long-term test using hydrogen as fuel on a 5 x 5 cm<sup>2</sup> SOFC at 850 °C, 1 A/cm<sup>2</sup> current density, hydrogen

- H<sub>2</sub>S has two effects:
  - drop of power output
  - increase of degradation rate
  - both effects are reversible until 100 ppm in H<sub>2</sub>

## Summary - Outlook

- SOFCs were operated:
  - On a number of fuels based on fossil or bio-derived sources
  - With high and stable power-output over 1500 hours and under technologically relevant conditions
- SOFC anodes are versatile catalysts:
  - For steam reforming of carbon containing fuels into CO and H<sub>2</sub>
  - Ammonia is decomposed into H<sub>2</sub> and N<sub>2</sub>
  - CO and hydrogen are electrochemically converted to CO<sub>2</sub> and H<sub>2</sub>O under release of electricity (and heat)
- Hydrogen sulfide in hydrogen fuel has an effect on the performance and stability of SOFCs, which is reversible until 100 ppm
- Effect of characteristic impurities has to be further studied (max. possible concentrations, removal technologies)

## Acknowledgement

We gratefully acknowledge support from our sponsors:

- Topsoe Fuel Cell A/S 
- Danish Energy Authority 
- Energinet.dk 
- EU 
- Danish Programme Committee for Energy and Environment
- Danish Programme Committee for Nano Science and Technology, Biotechnology and IT

# Test Set-up

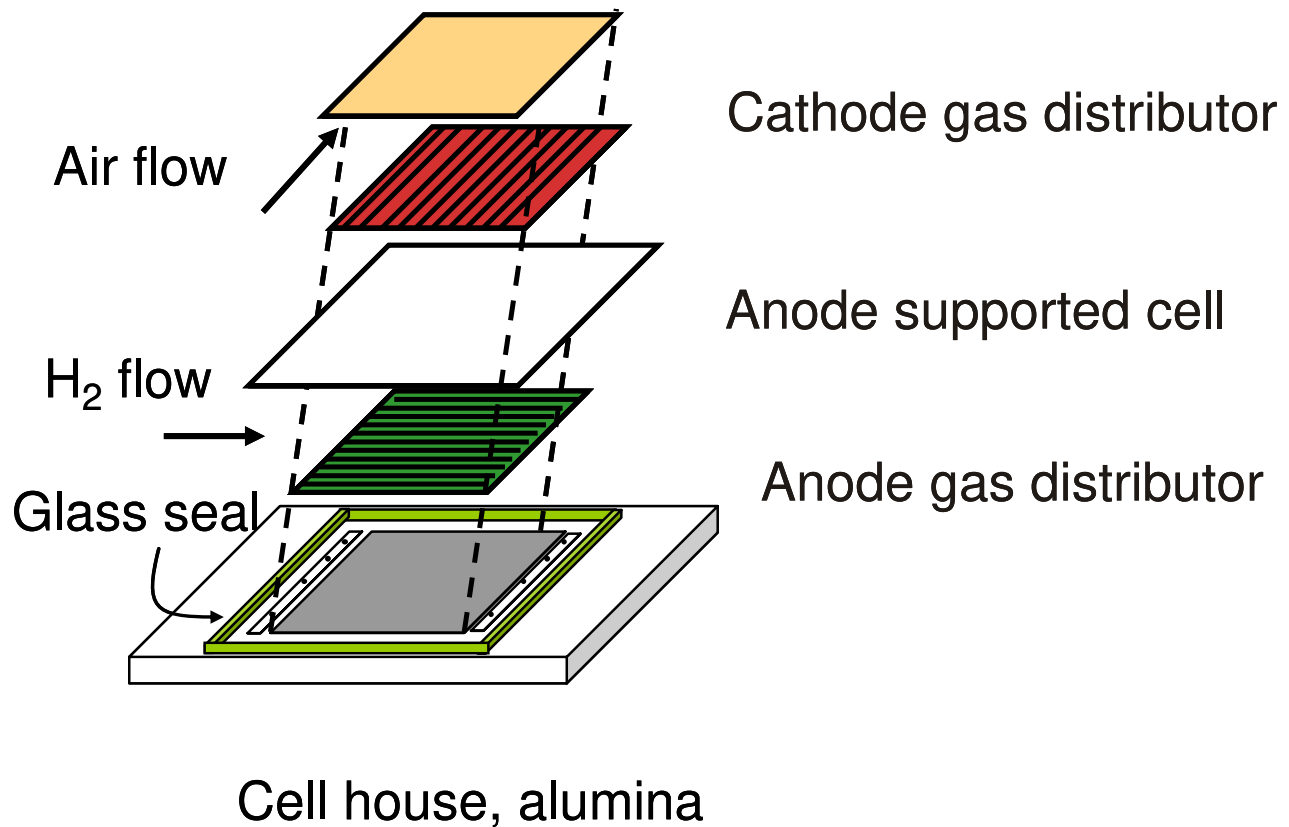

## Carbon formation at SOFC anode

- (Thermodynamic) risk of carbon formation for all carbon containing fuels

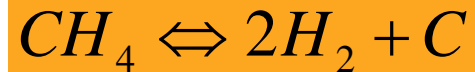

- Solution: Addition of sufficient water/steam

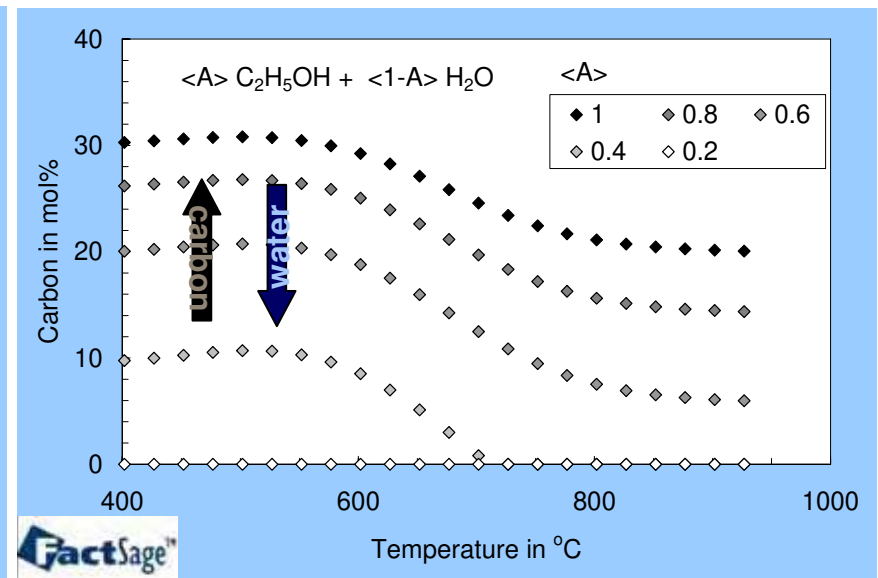
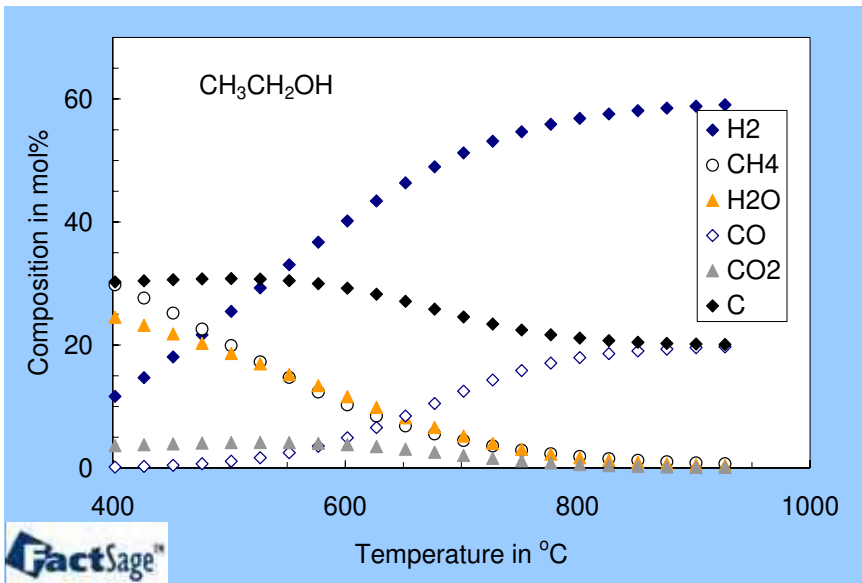

# Thermodynamics of ammonia decomposition

- Nearly complete ammonia decomposition at SOFC operating temperature

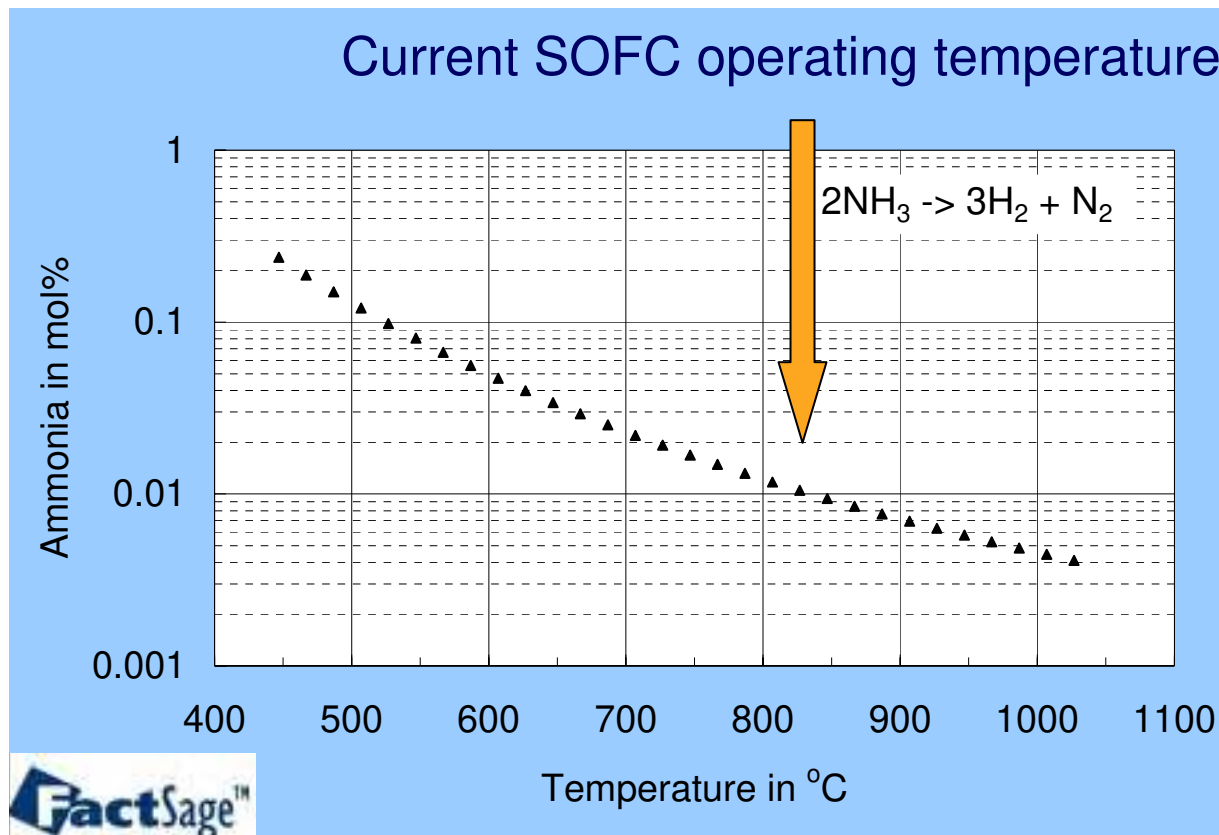

# Ammonia decomposition

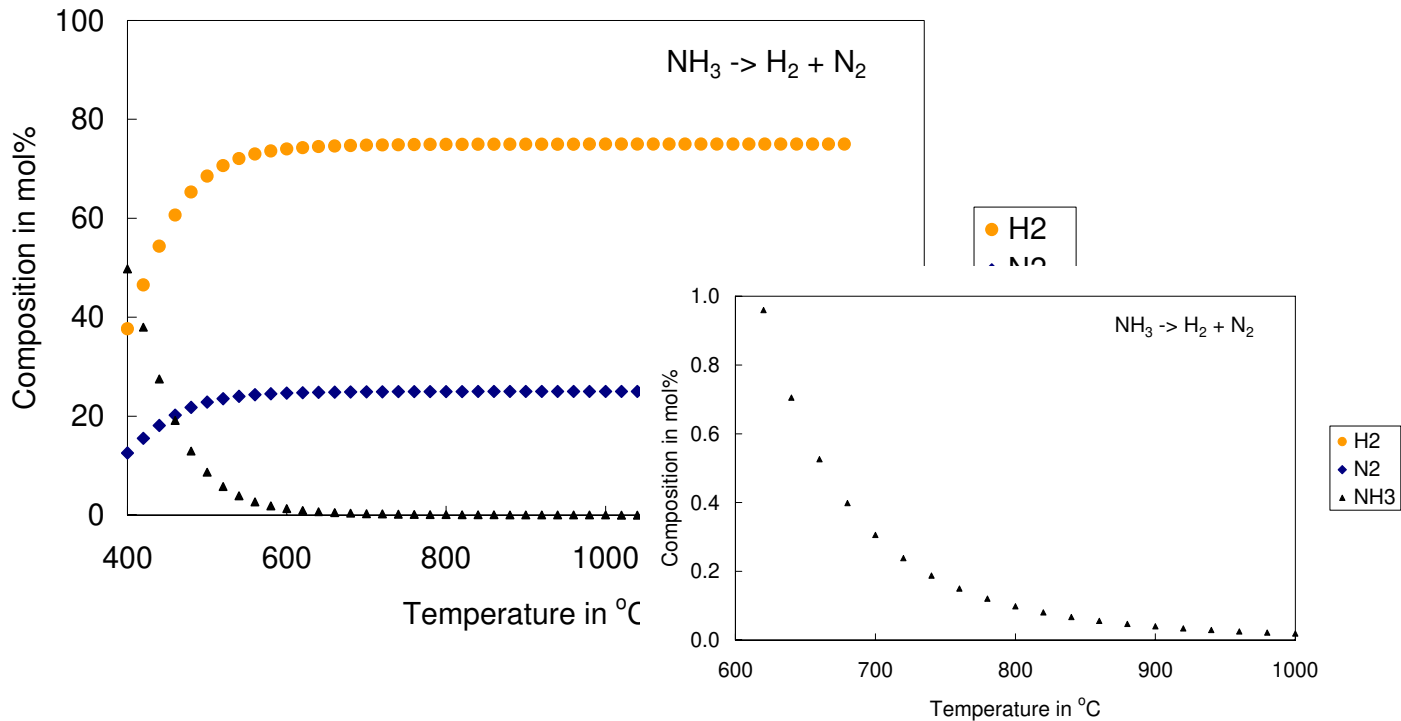

# Ammonia – Power output

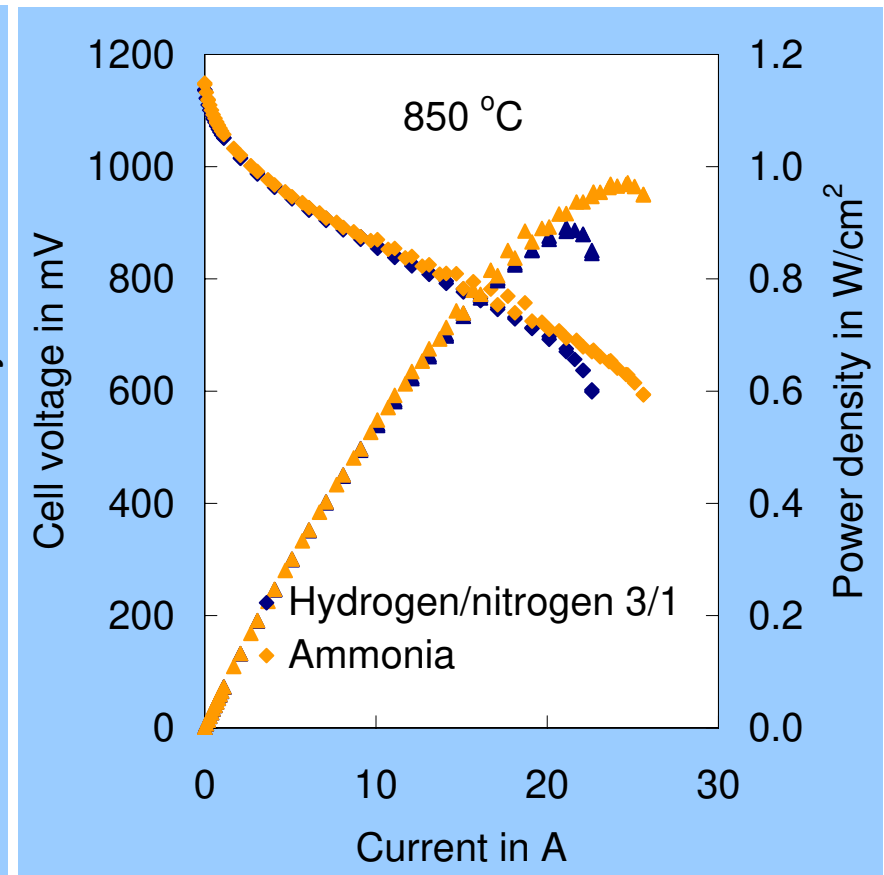
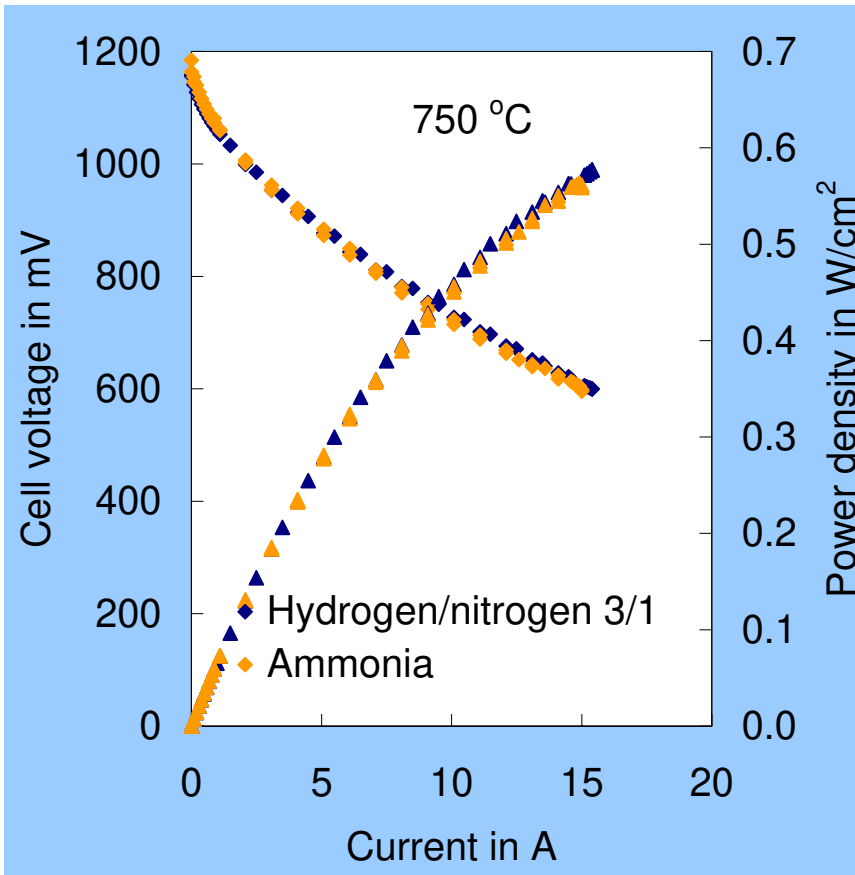



# Fuel Cell - Shaft Power Packs FC-SPP

RISØ Energy Conference 2007

Centre Manager  
Renewable Energy & Transport

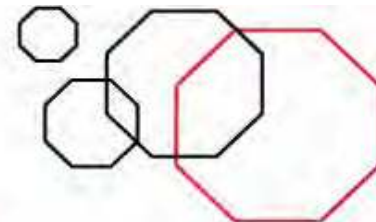

# Current Concept

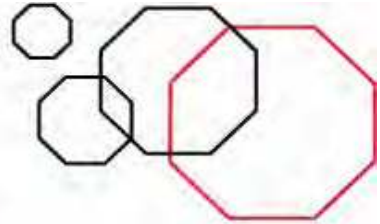
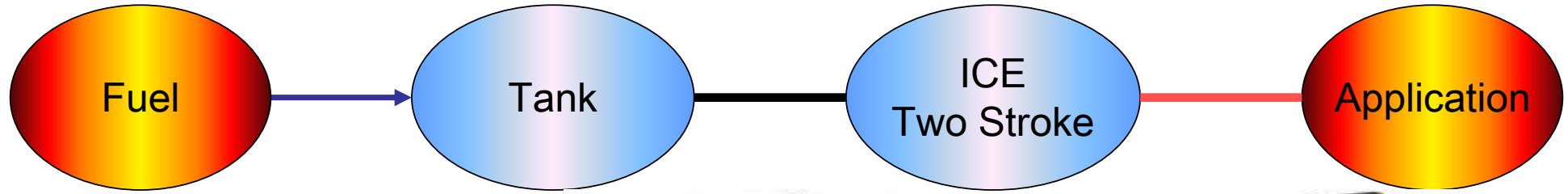

# New Concept

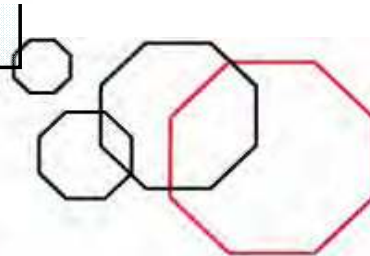
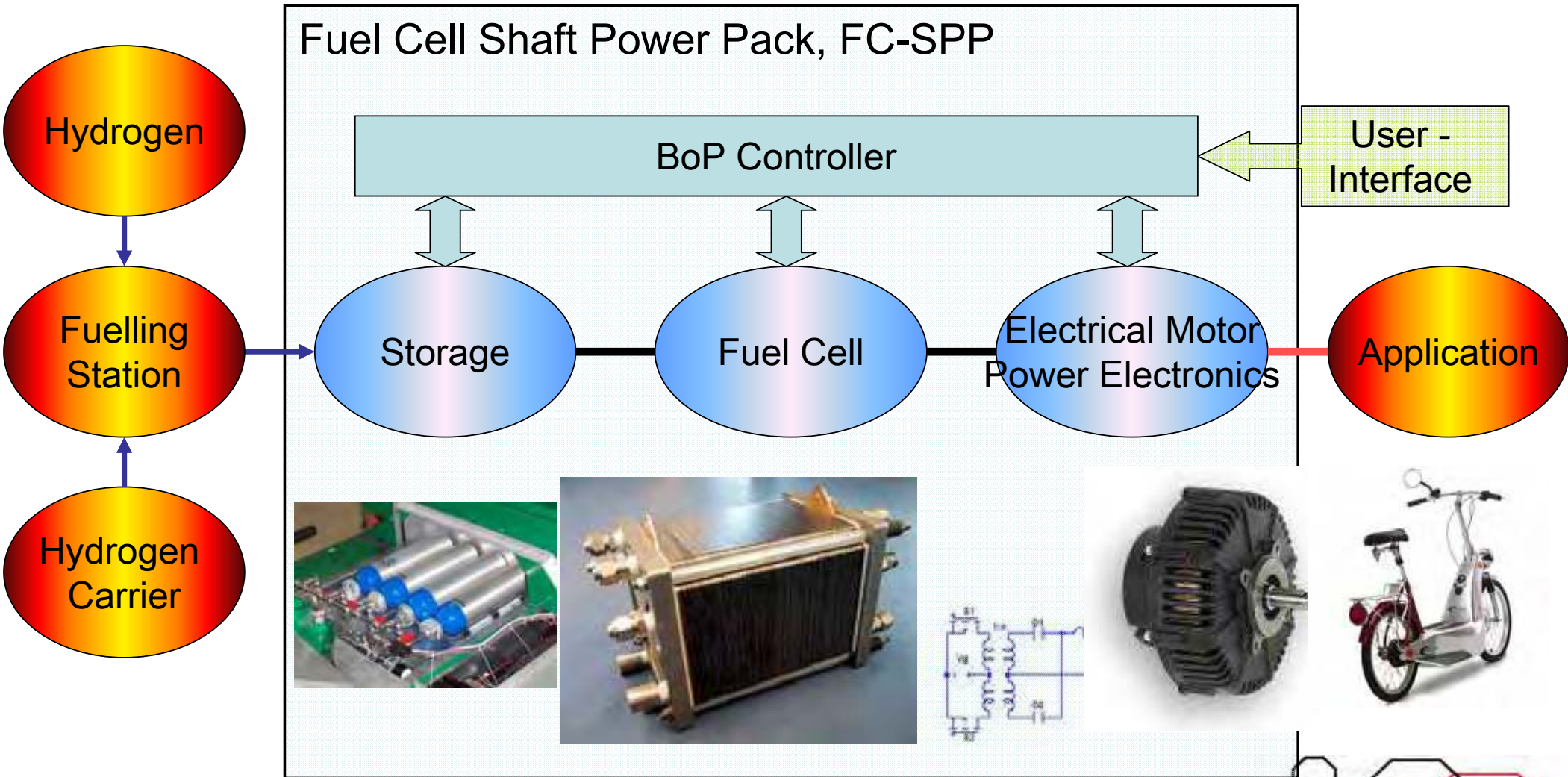

## Vision:

- Through applied research, development and demonstration, the consortium will create the foundation for a production of hydrogen power packs
- The consortium will look at the market for hydrogen based power packs and develop tools that ensures the basis of a commercial production

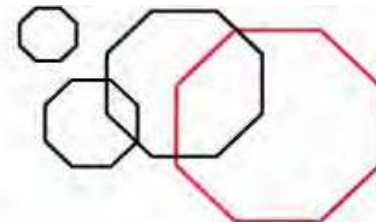

# Project Team & Budget

**Total budget approx. 30 mill. DKK (5.5 mill. USD)**

**Project duration: 3 years**

## Demonstration team

- Cykellet/DSR Scandinavia
- GMR Maskiner
- Trans-Lift
- Falsled Højtryk

## Research team

- Aalborg University
- The Danish Technological Institute
- Copenhagen Business School
- Hydrogen Innovation Research Centre

## Development team

- Dantherm Airhandling
- Migatronic
- H2Logic
- Parker Hannifin DK
- kk-electronic
- Xperion
- EGJ Development

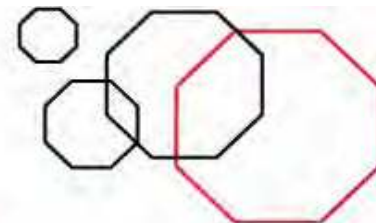

# Project Structure

Mercantile Research  
CBS

Technical Research  
AAU

5 Ph.D. Projects

Applied Research & Development  
DTI/HIRC

Fuel Cell Shaft Power Packs

Demonstration projects  
4 applications  
Component and System Suppliers and End-users

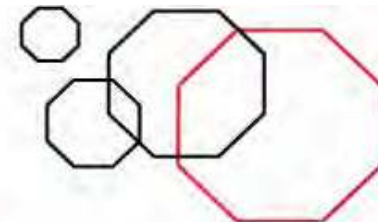



# The Research Team

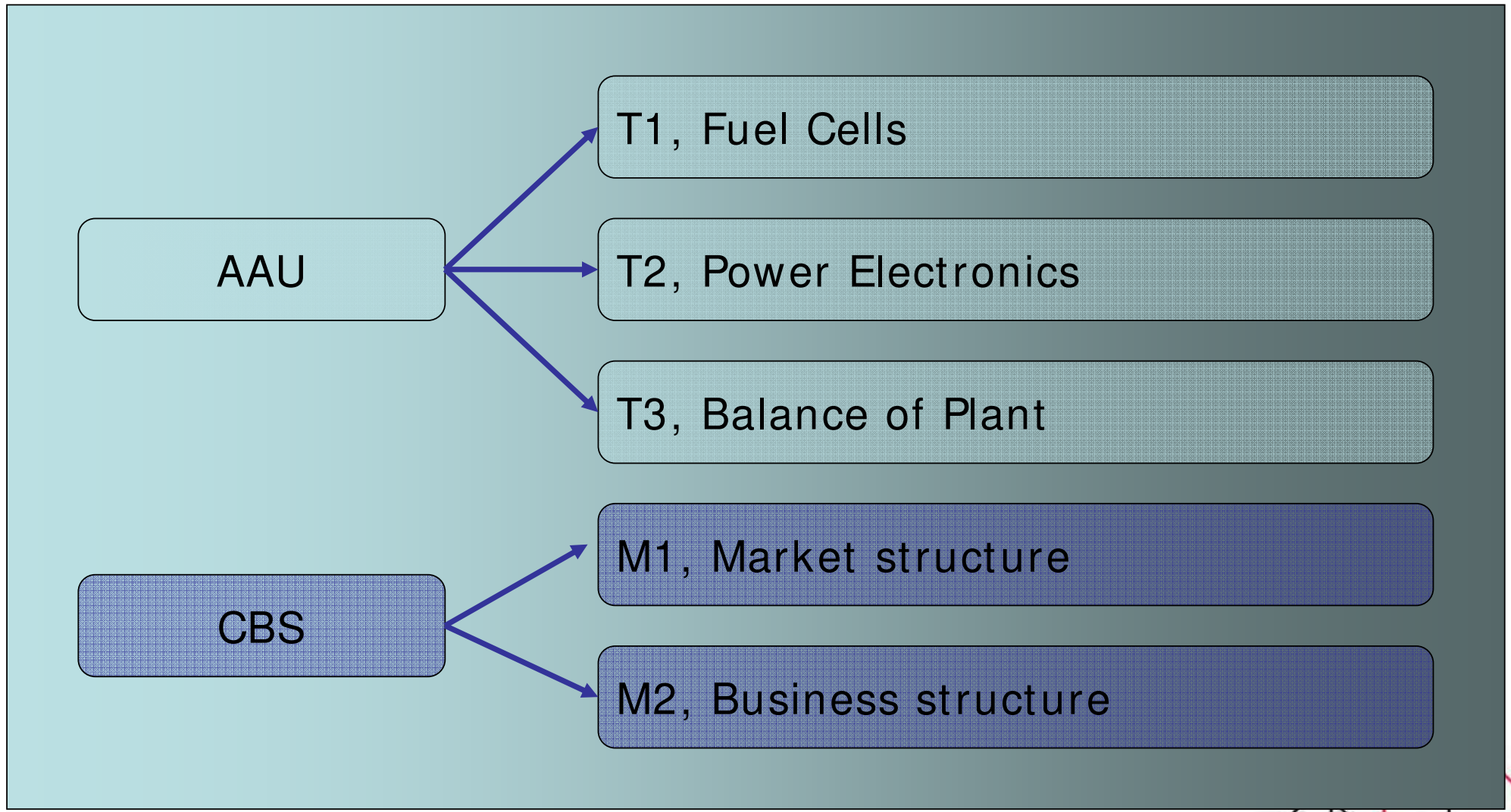

# Technical PhD 1: Experimental Characterization of Fuel Cells

- Investigation of the cathode manifold flow
- Gas-phase micro-PIV (Particle Image Velocimetry) on bipolar plate channels (at University of Victoria BC, Canada)
- Electrochemical Impedance Spectroscopy (EIS)
- *In situ* temperature measurements (SEMOS)

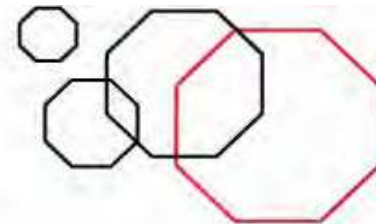
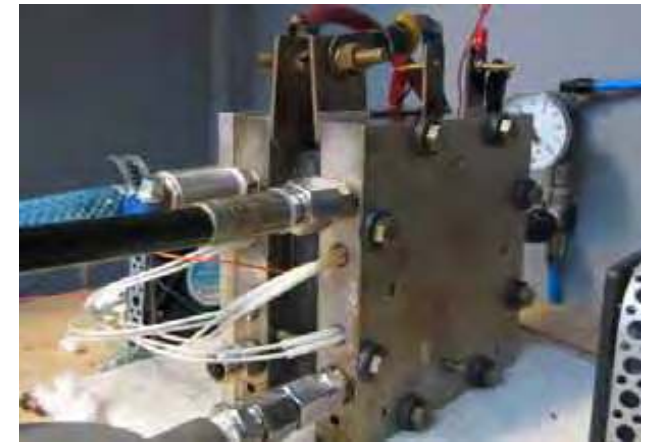
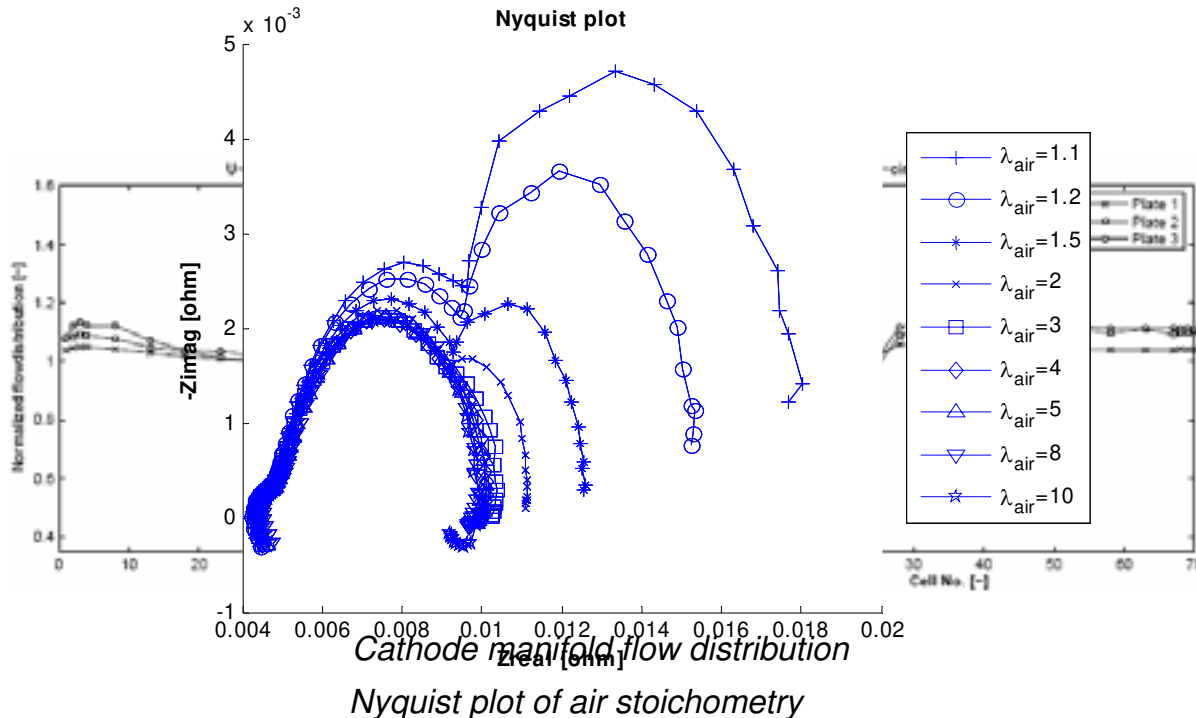



# Technical PhD 2: Power Electronics

- Field measurement of drive profile (DTI)
- Design of propulsion system
- Energy management strategies
- Transient modeling of fuel cell, battery, ultra capacitor, DC/DC converters, DC/AC converters and motor



Source: [www.gmr.dk](http://www.gmr.dk)

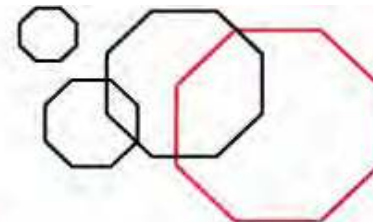
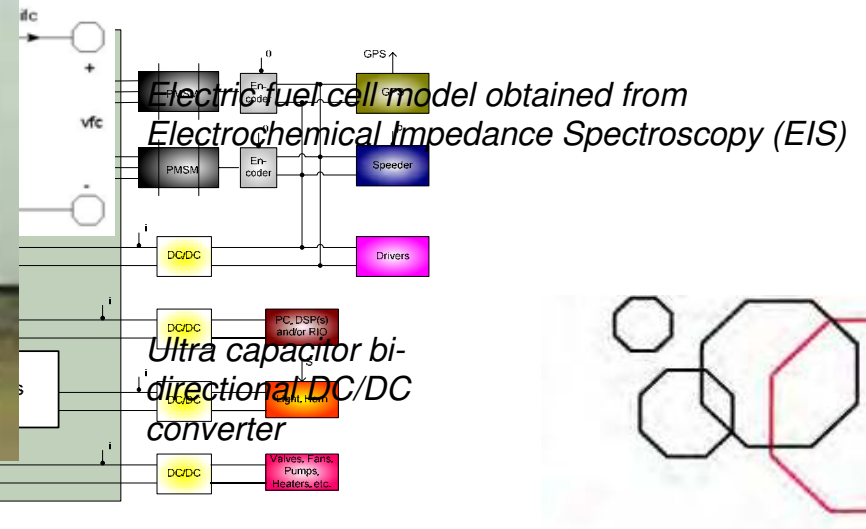
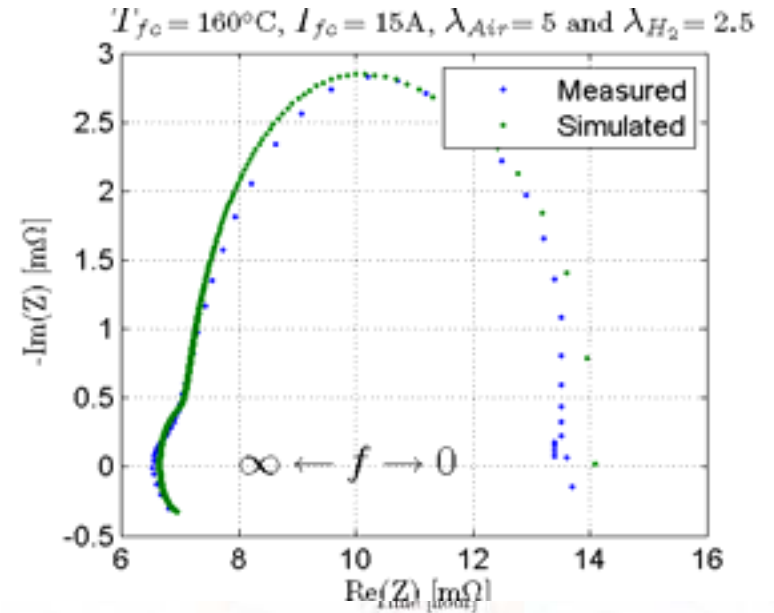

# Technical PhD 3:

## High Temperature PEM Fuel Cell System Design and Control

- HTPEM fuel cell system design
  - System configuration, evaluation of different system concepts
  - Modeling of system components and fuel cell stack
- Fuel cell system control
  - Identification of critical control states
  - Model based control design
  - Implementation and testing of developed control strategies
- Application control of electrical hybrid vehicle
  - Overall application control strategy control development
  - Performance and field testing of vehicle for model verification

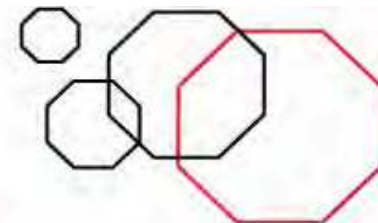
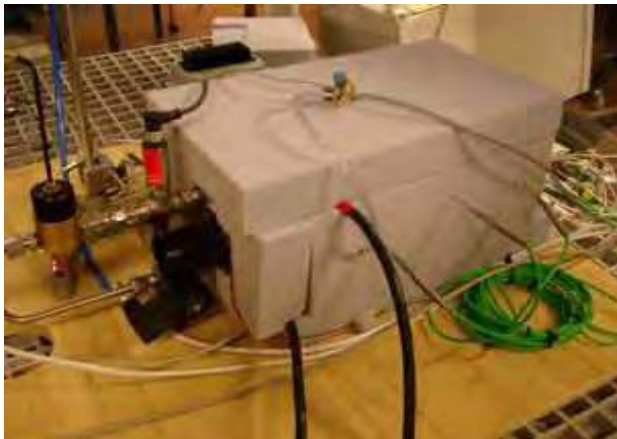

# Mercantile PhD 1: FC market drivers and dynamics

FC is a *systemic* innovation: value creation of components depends upon incorporation into a system

- Co-evolution of components, systems, and markets
- Dynamic processes unfolding from *feedback mechanisms*
- Feedbacks transcend disciplinary boundaries (social/technical/economic factors)
- Analytical tool: system simulation

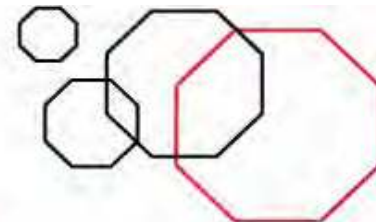

# Mercantile PhD 2: Building Absorptive Capacity in Research Collaboration

- *Absorptive capacity – a concept explaining how companies acquire, assimilate and exploit knowledge from external sources*
- To what extent is research collaboration a vehicle for development of absorptive capacity?
- How to manage the collaboration to maximise benefits for participants not only in terms of technological research results, but also development of organisational skills?
- Project as an integral part of FC-SPP: using observations and experience of the companies participating in FC-SPP for advancing the research on one hand, and disseminating results to the companies in order to help them better benefit from the cooperation.

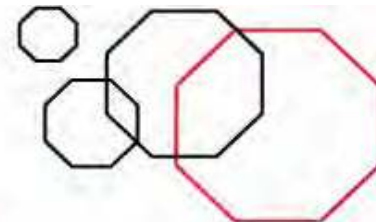

# Four demonstration projects

1. Cykellet/DSR Scandinavia (Electric powered bike)
2. Trans-Lift (Pallet truck)
3. GMR Maskiner (Truck for maintenance of "green areas")
4. H2O Skypump (Professional high pressure cleaner)

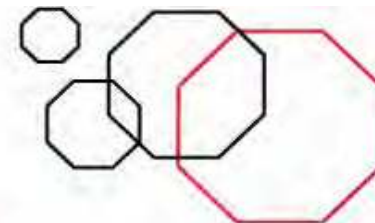



# Project types

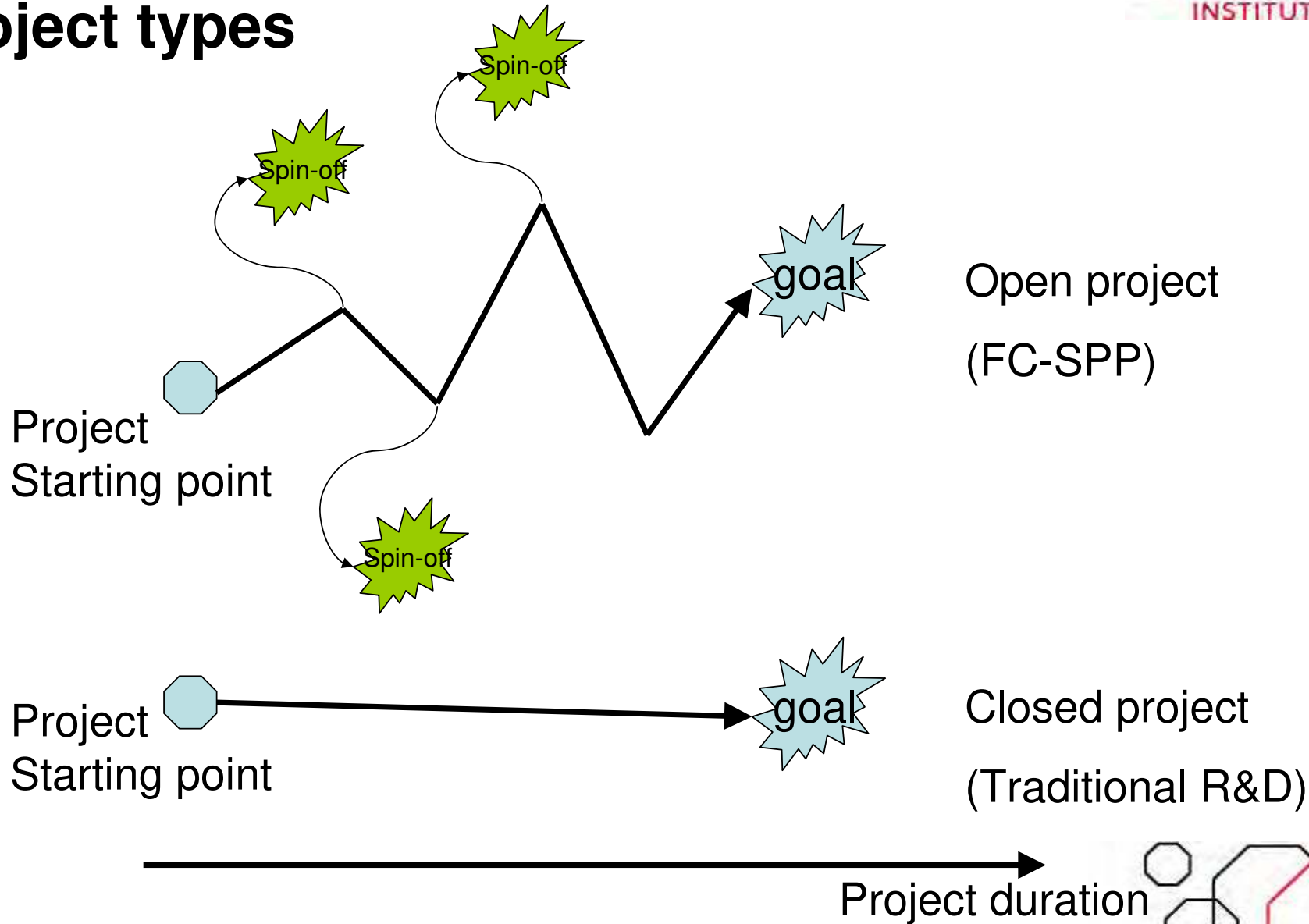

# Trans-Lift - case

Trans-Lift design and produce battery powered vehicles for goods handling.

## Problems:

- batteries are expensive
- must be replaced from time to time
- must be recharged

## Advantages with FC:

- Lower operating costs
- No wasted time for battery charging

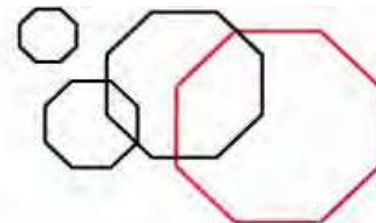

# Migatronik - case

Migatronik a welding machine producer



Problems:

- None...

Possibilities with FC:

- Create a new product range
- Enter new markets
- More turnover
- Less vulnerable

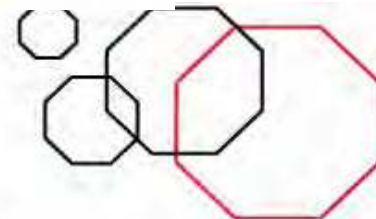



**Thank you!**

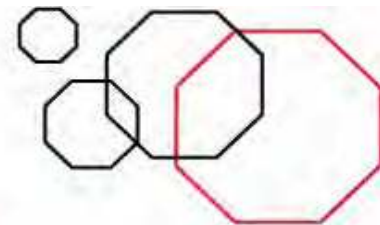

# Overview of U.S. DOE's Coal RD&D Programs

## *Clean and Secure Energy From Coal*



**Scott M. Smouse**  
International Coordination Team Leader  
National Energy Technology Laboratory

**Risø International Energy Conference 2007**  
Copenhagen, Denmark  
22-24 May 2007

Office of Fossil Energy  
U.S. Department of Energy



# Energy Demand Today

# Energy Demand 2030

101 QBtu / Year  
85% Fossil Energy

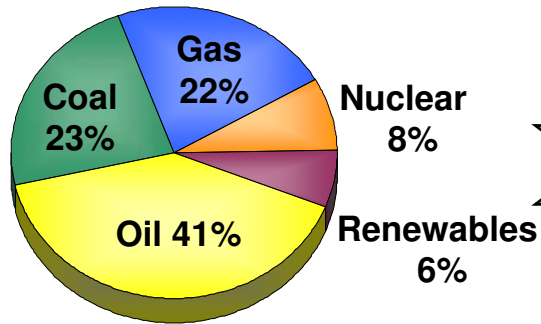

131 QBtu / Year  
86% Fossil Energy

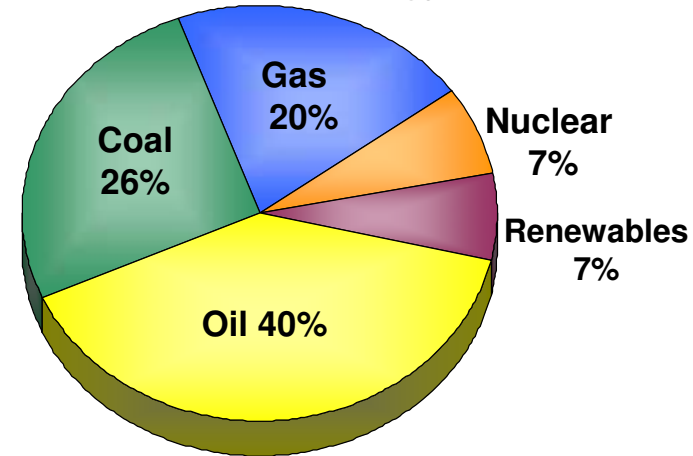

465 QBtu / Year  
86% Fossil Energy

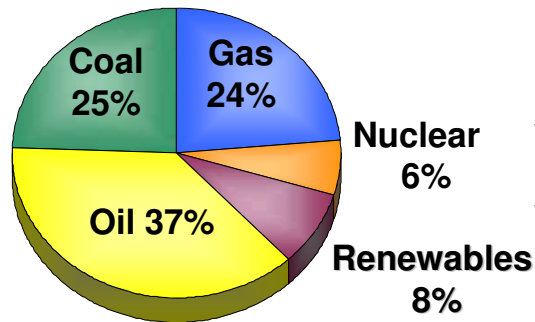

722 QBtu / Year  
87% Fossil Energy

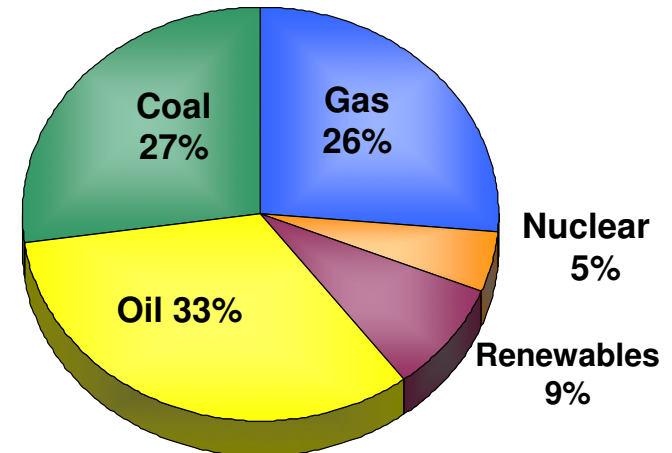

# U.S. Coal Utilization Outlook

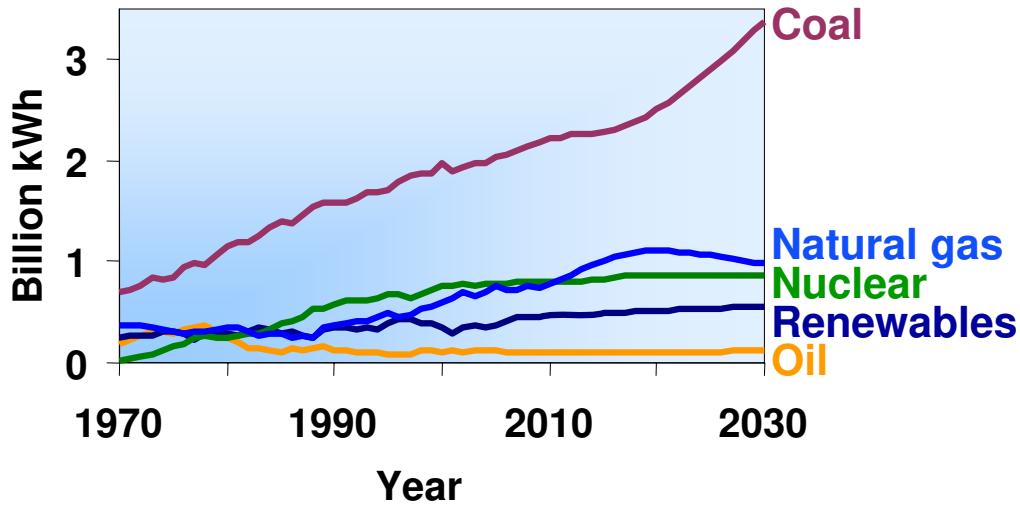

*Coal dominates electricity generation*



Upper figure: DOE EIA, AEO 2006, Figure 5  
Lower figure: Energy & Electricity per DOE EIA, AER 2004  
GDP per U.S. DOC, Bureau of Economic Analysis

# 250-Year Supply of Coal at Current Demand Levels

## U.S. Fossil Fuel Reserves / Production Ratio

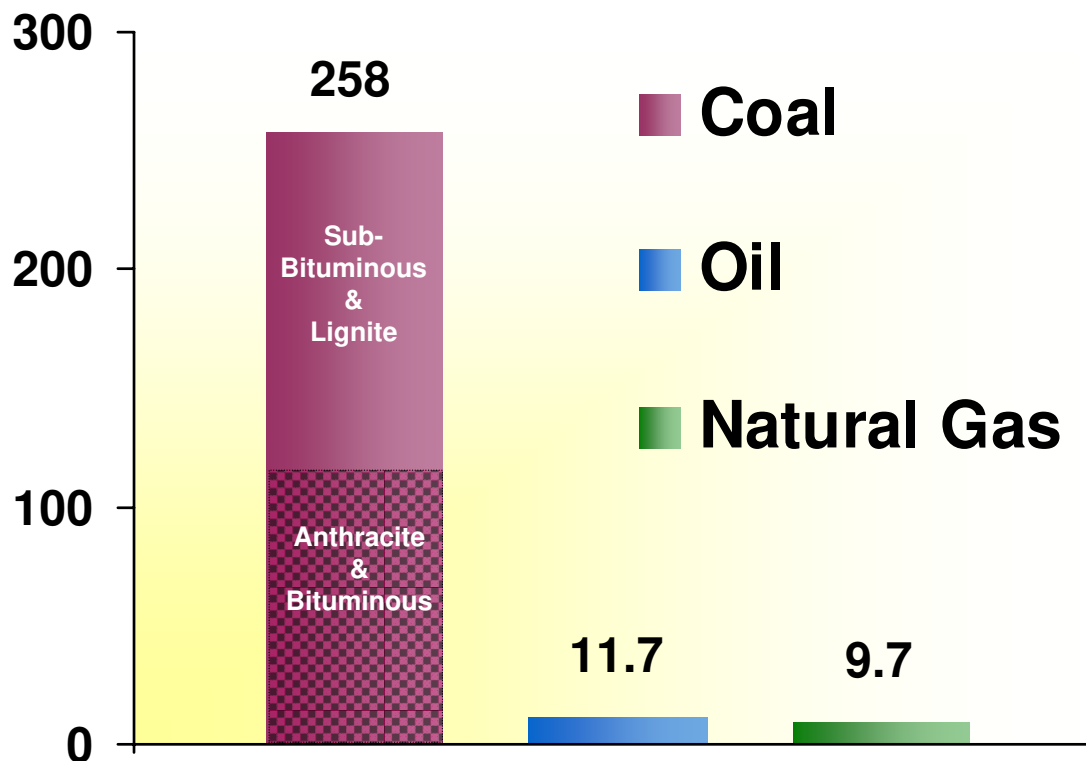

# 174 Added GW - Double the 87 GW in DOE's EIA Annual Energy Outlook 2005

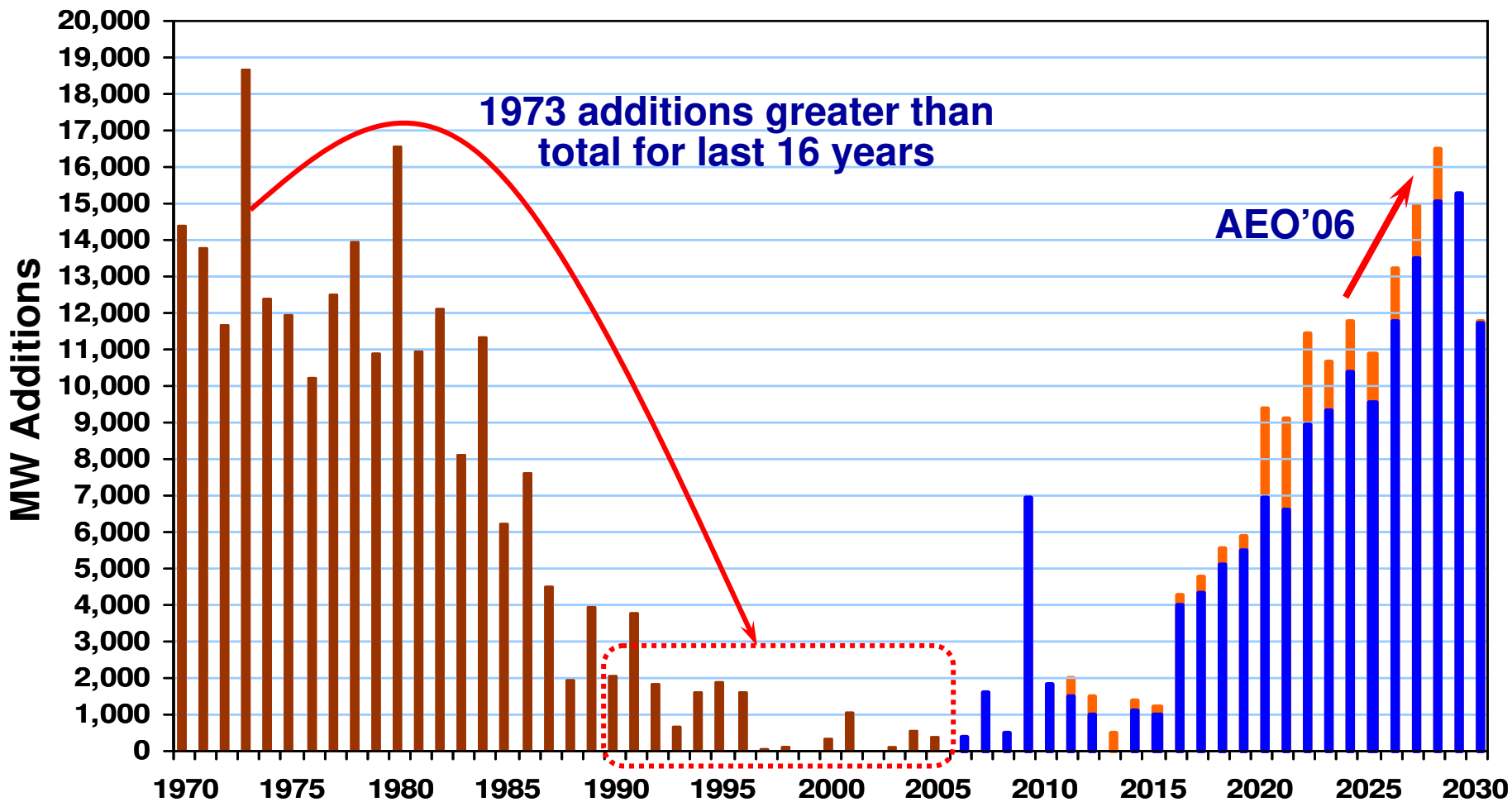

*Coal Adds 154 GW New Capacity Plus 19 GW of CTL  
(Reference case with 5 additional years to 2030)*



# DOE Strategic Plan

**1.1 Energy Diversity** – Increase our energy options and reduce dependence on oil, thereby reducing vulnerability to disruption and increasing the flexibility of the market to meet U.S. needs.

**1.2 Environmental Impacts of Energy** – Improve the quality of the environment by reducing greenhouse gas emissions and environmental impacts to land, water, and air from energy production and use.

**1.3 Energy Infrastructure** – Create a more flexible, more reliable, and higher capacity U.S. energy infrastructure.

**1.4 Energy Productivity** – Cost-effectively improve the energy efficiency of the U.S. economy.



# R&D Challenges for Coal Technology

- “Near-zero” emissions
- CO<sub>2</sub> management
- High efficiency
- Water use
- By-product utilization
- Flexible (feedstocks, products, siting)
- Cost competitive with other energy choices





# Office of Fossil Energy's Coal & Power Program

**DEMONSTRATION PROGRAM**  
Clean Coal  
Power Initiative

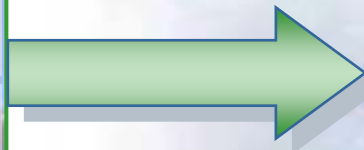

*Support  
Presidential Initiatives:  
Clear Skies  
Climate Change  
Energy Security*

**FUTUREGEN**  
Integrated sequestration,  
hydrogen, and power  
research facility

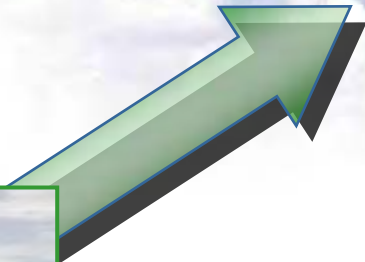

**CORE R&D PROGRAM**

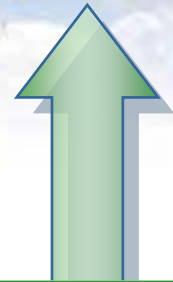

# Pathway to Clean and Secure Electricity from Coal



**Existing Plants**



**Clean Coal Successes**



**Near-Zero Emissions**

**Technology Research, Development & Demonstration**



# DOE's Office of Fossil Energy

## Advanced Coal Power Systems Goals

- **2010:**

- 45-50% Efficiency (HHV)
- 99% SO<sub>2</sub> removal
- NO<sub>x</sub> < 0.01 lb/MM Btu
- 90% Hg removal
- \$1,000/kW (2002 \$)

- **2012:**

- 90% CO<sub>2</sub> capture
- **<10% increase in COE with carbon sequestration**

- **2015**

- Multi-product capability (e.g., power, liquid fuels, hydrogen, SNG)
- 50-60% efficiency (without carbon capture)

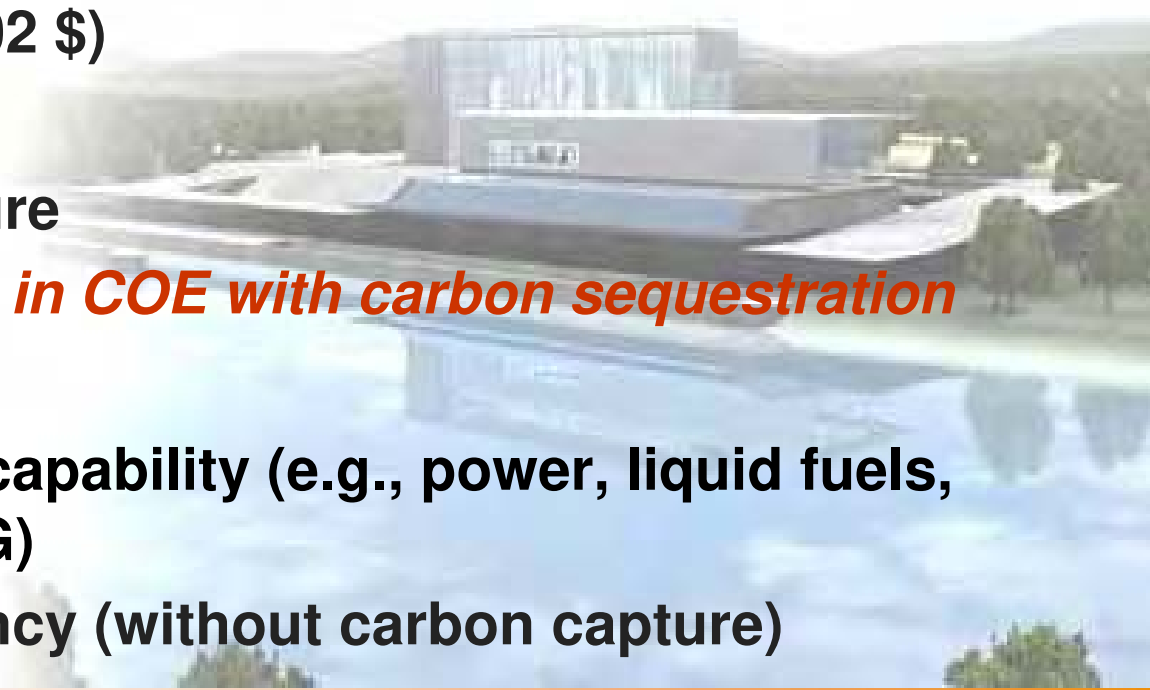

# Coal & Power Core R&D Program

- Innovations for Existing Plants
- Advanced Integrated Gasification Combined Cycle
- Hydrogen & Syngas
- Carbon Sequestration
- Fuel Cells
- Advanced Research
- Advanced Turbines

*Roadmap Developed  
for Each Program  
with Industry*



# Coal & Power Program

## Addresses Both Near-Term and Long-Range Needs

- **Short-term:** keep existing fleet in service; prepare for transition to near-zero-emission future
  - SO<sub>2</sub>, NO<sub>x</sub>, Hg
  - Plant optimization and control
  - Reduced carbon intensity
- **Long-term:** add near-zero emission energy plants
  - IGCCs to market
  - Advanced materials
  - Ultra-high-efficiency hybrid systems
  - CO<sub>2</sub> capture and storage





# Carbon Capture and Storage Opportunities

## Thousands of Years of Potential Storage Capacity Worldwide

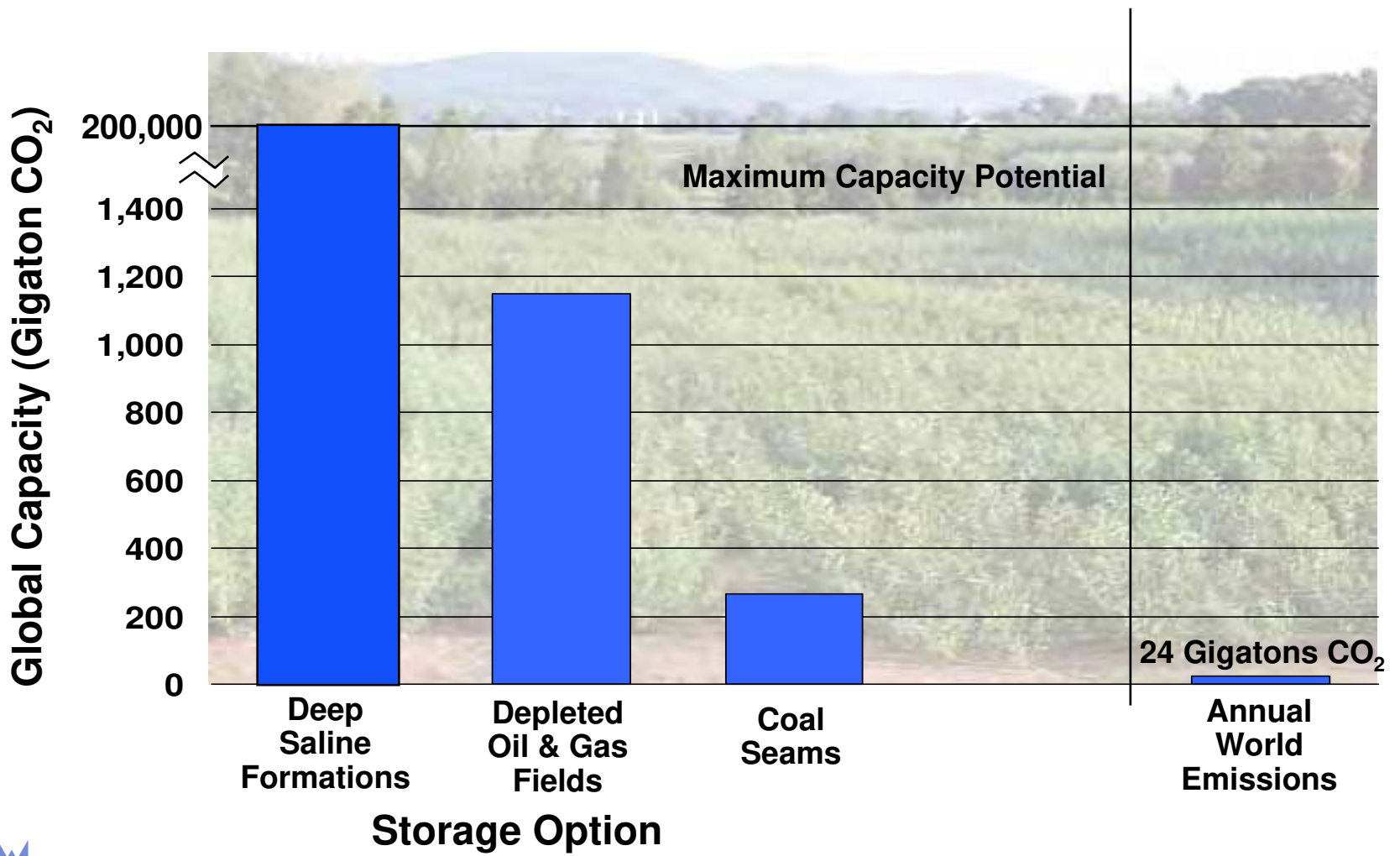

*Storage Options from IEA Technical Review (TR4), March 23, 2004, DOE/EIA. World Emissions from International Energy Outlook 2003, Table A10*

# Carbon Sequestration Program

## Technology R&D Pathways

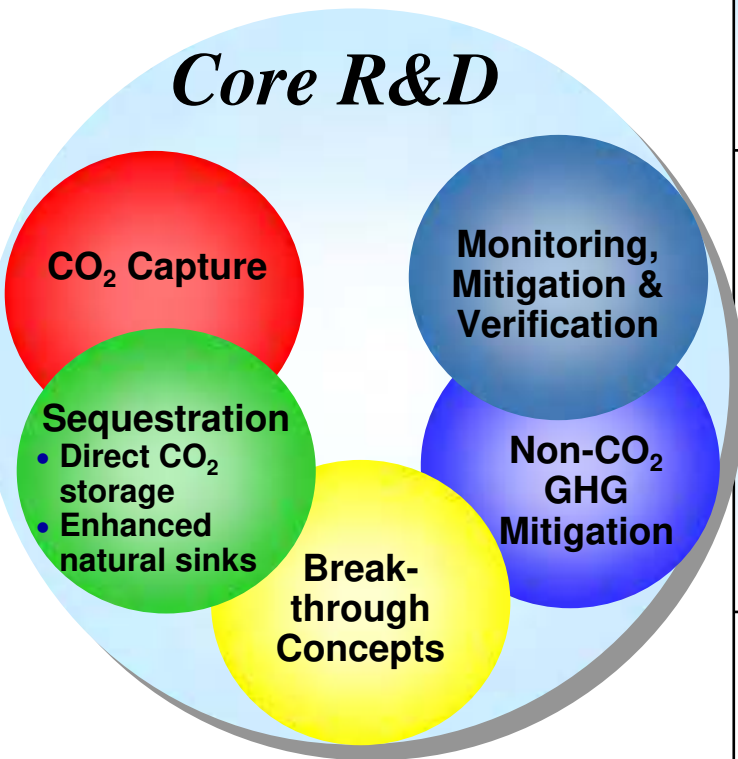

<b>Capture</b>	<ul style="list-style-type: none"> <li>• Post-combustion Capture</li> <li>• Oxygen combustion</li> <li>• Pre-combustion capture</li> <li>• Chemical looping</li> </ul>
<b>Sequestration</b>	<ul style="list-style-type: none"> <li>• Depleting oil reservoirs</li> <li>• Unmineable coal seams</li> <li>• Saline formations</li> <li>• Enhanced terrestrial uptake</li> </ul>
<b>MM&amp;V</b>	<ul style="list-style-type: none"> <li>• Advanced soil carbon measurement</li> <li>• Subsurface measurements</li> <li>• Remote sensing/above-ground MM&amp;V</li> <li>• Fate and transport models</li> </ul>
<b>Breakthrough Concepts</b>	<ul style="list-style-type: none"> <li>• Advanced Capture</li> <li>• Bio-accelerated sequestration</li> <li>• Niches</li> </ul>
<b>Non-CO<sub>2</sub> GHG</b>	<ul style="list-style-type: none"> <li>• Landfill Methane Capture and Use</li> <li>• Mine Ventilation Methane Capture</li> </ul>

# DOE's FY2006 Sequestration Program

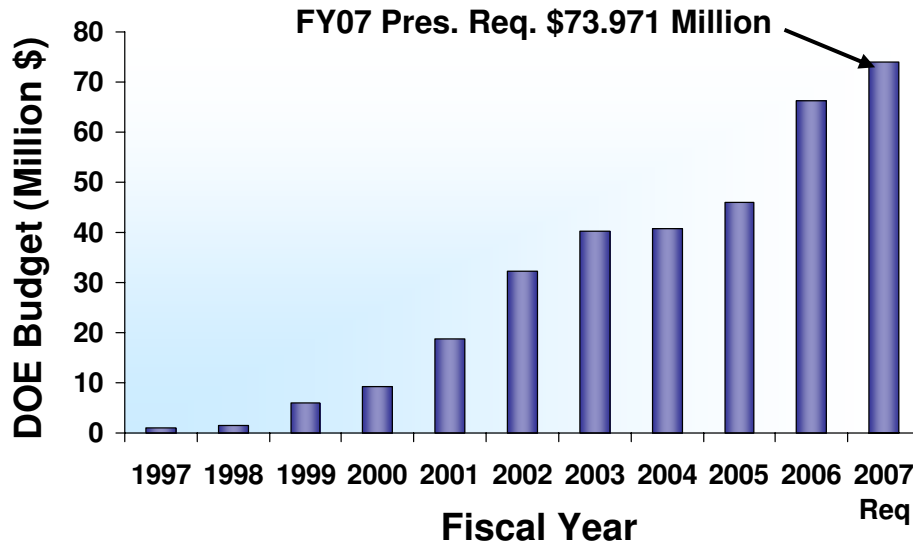

- **Diverse research portfolio**  
~ 70 R&D Projects

FY2006 Budget

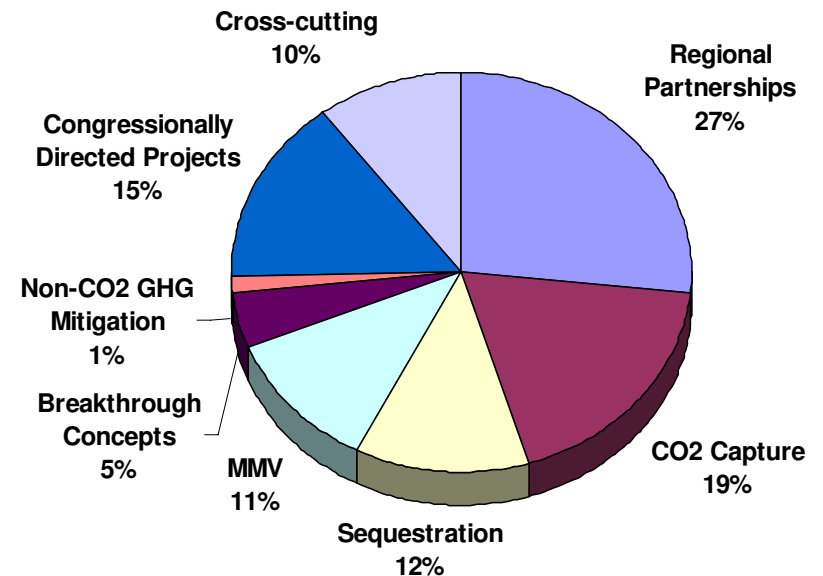

- **Strong industry support**  
~ 39% cost share on projects
- **Federal Investment to Date**  
~ \$260 Million





# Sequestration Program Goals

## Develop Technology Options for GHG Management

- **CCS R&D Goals**
  - Options for IGCC and PC-based electricity generating technologies
- **Sequestration/Storage R&D Goals**
  - Predict CO<sub>2</sub> storage capacity with +/- 30% accuracy
  - Develop best practice reservoir management strategies that maximize CO<sub>2</sub> trapping
- **Monitoring, Mitigation & Verification**
  - Ability to verify 95% of stored CO<sub>2</sub>
  - CO<sub>2</sub> material balance to >99%

### Cost Performance Goals

Year	COE Penalty IGCC Plants (% Increase)	COE Penalty PC Plants (% Increase)
2002	30	80
2012	10	20
2015	<10	10
2018*	0	0

\*Cost/Energy offset from sequestering CO<sub>2</sub> with criteria pollutants NO<sub>x</sub>, SO<sub>x</sub>, H<sub>2</sub>S (gasification)



# Carbon Storage – Science is Growing

*Understanding of storage mechanisms is critical to viability as a long-term option*

- Physical Trapping
- Residual Phase Trapping
- Solution/Mineral Trapping
- Gas Adsorption

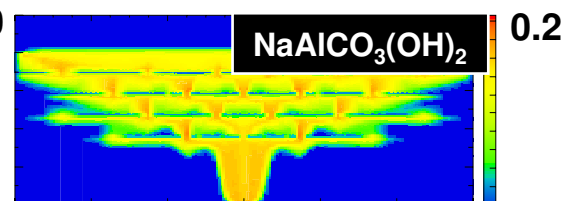
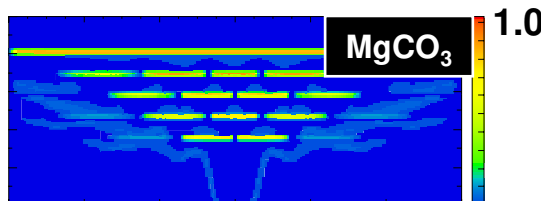
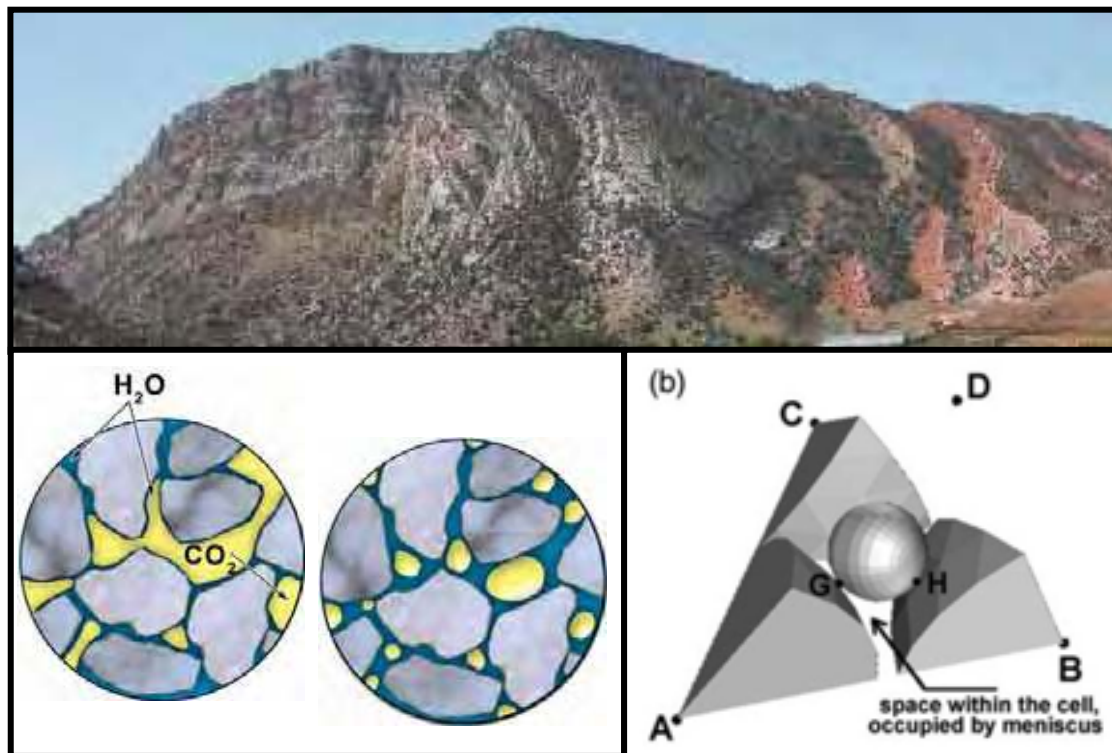

# Carbon Sequestration Regional Partnerships

## *“Developing the Infrastructure for Wide-Scale Deployment”*

### Phase I (Characterization)

- 7 Partnerships (40 states)
- 24 months (2003-2005)



### Phase II (Field Validation)

- 4 years (2005 - 2009)
- All seven Phase I partnerships continued
- \$100 million federal funds
- \$45-million cost share

### Phase III (Deployment)

- 10 years (2008-2017)
- Several large-scale injection tests

# Regional Carbon Sequestration Partnerships

Phase II Validation Tests - Injecting between 750 – 525,000 tons of CO<sub>2</sub>

Representing:

- >300 Organizations
- 40 States
- 4 Canadian Provinces
- 3 Indian Nations
- 34% cost share

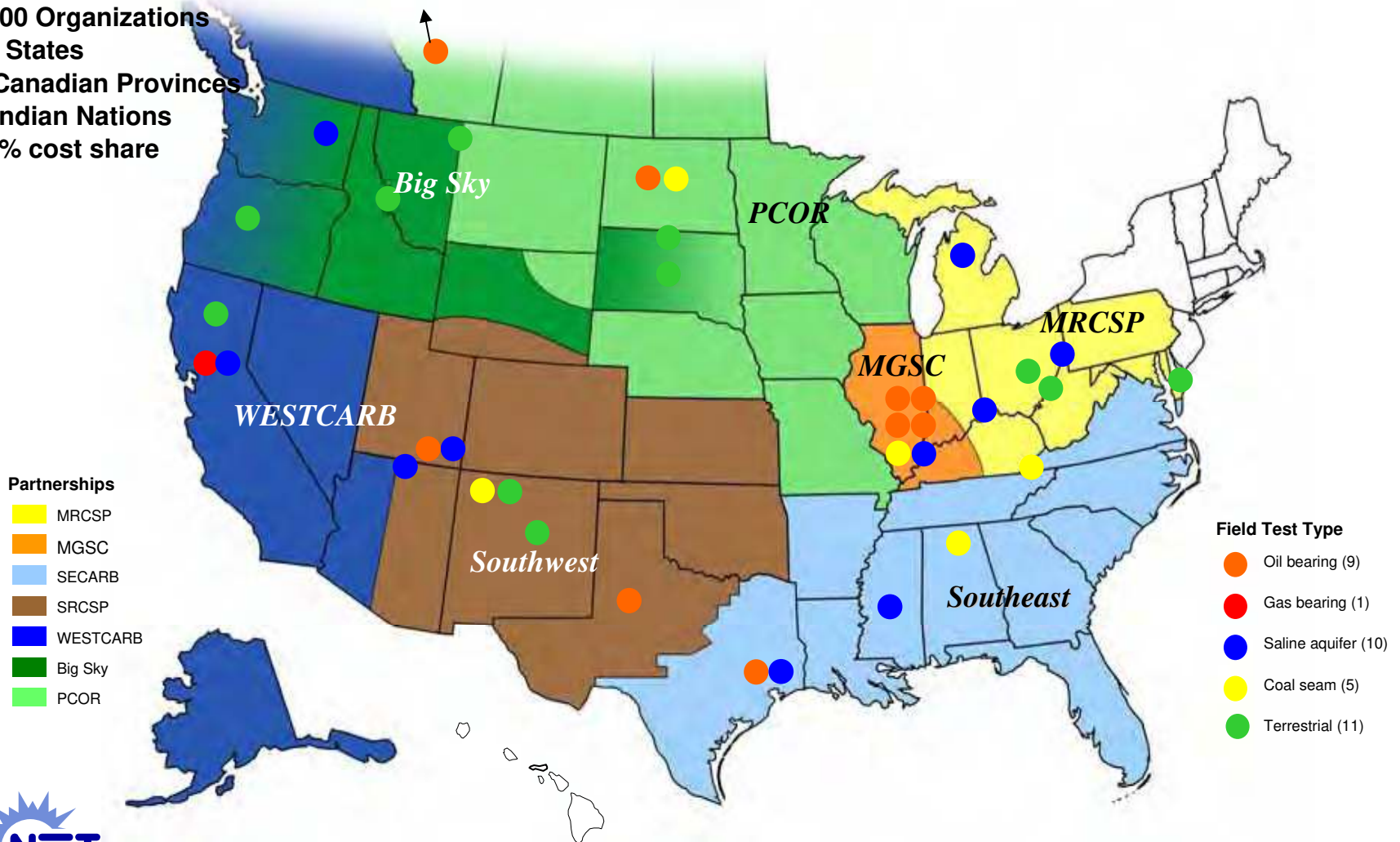

# Break-Through Capture Concepts

## Ionic Liquids

- CO<sub>2</sub> is *highly soluble* in some ionic liquids
- Non-volatile liquid and high thermal stability
- Ability to capture SO<sub>2</sub> with one solvent

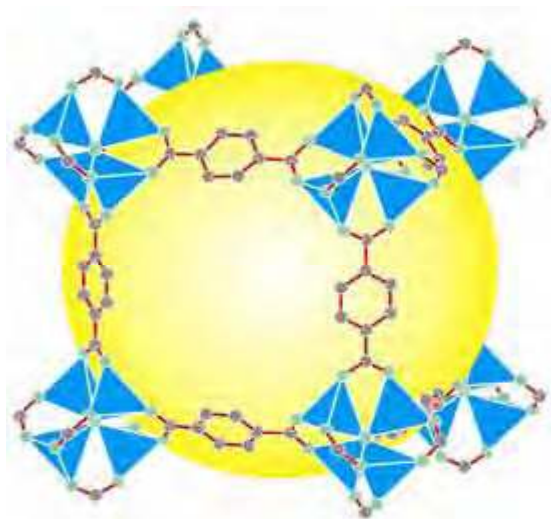
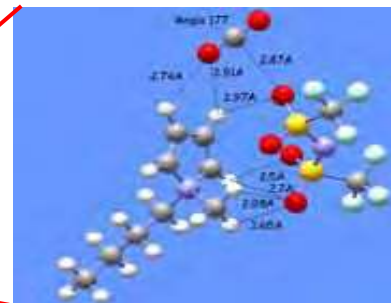
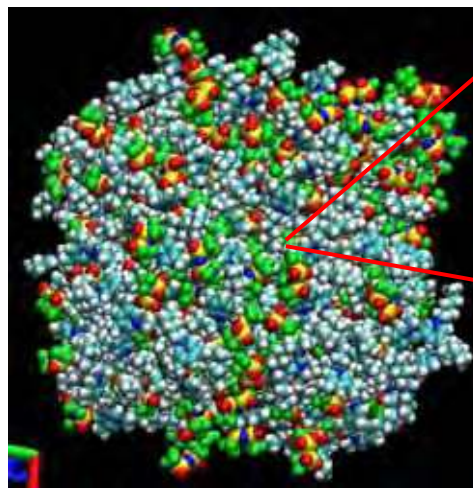

## Metal Organic Frameworks

- Highly porous materials
- Thermally stable
- High loading capacities
- Low manufacturing costs



# Break-Through Capture Concepts

## Thermally Optimized Membranes

- Order of magnitude higher selectivity than current polymers
- Selective from room temp to 400°C
- Promising preliminary results

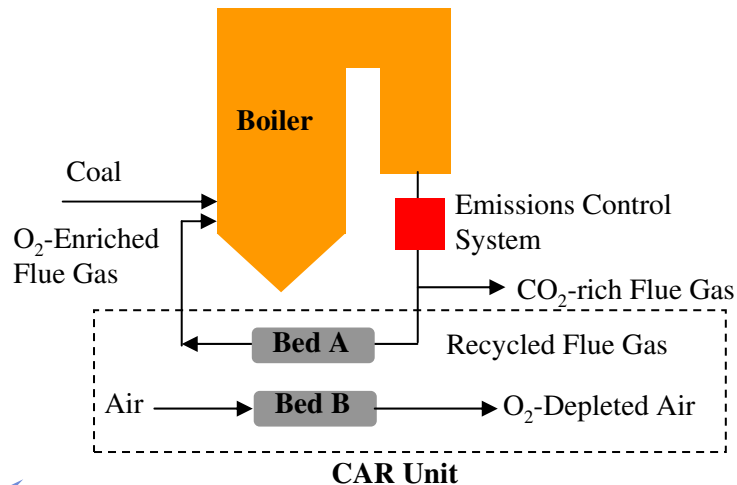

## Ceramic Autothermal Recovery (CAR) Technology

- Oxy-fuel combustion option for power generation
- High-temperature, steady-state process
- Perovskites pellets, fixed bed
- Oxygen-enriched product stream, high O<sub>2</sub> recovery

# Ongoing, Large-Scale CO<sub>2</sub> Sequestration Projects

## *Weyburn CO<sub>2</sub> EOR Project*

- Pan Canadian Resources
- 200-mile CO<sub>2</sub> pipeline from Dakota Gasification Plant
- Enhanced Oil Recovery in Canada



## *Sleipner North Sea Project*

- Statoil
- CO<sub>2</sub> sequestered - Utsira Formation
- Currently monitoring CO<sub>2</sub> migration
- Separates CO<sub>2</sub> from natural gas
- \$36-50/tonne CO<sub>2</sub> tax



# DOE's Coal Demonstration Programs *Implemented Through Competition*

**Industry / Government  
Partnership**

**Fleet of Tomorrow**

**CCPI**

**Clean Coal Power  
Initiative - 2002-2012**

**PPII**

**Power Plant Improvement  
Initiative - 2001**

**CCT**

**Clean Coal Technology  
Program - 1985-1993**

**Minimum  
50% Non-  
Federal Cost  
Share**

**Existing Power Plant Fleet**

**Repayment**





# IGCC Technology in Early Commercialization

## *U.S. Coal-Fueled Plants*

- **Wabash River**
  - 1996 Powerplant of Year Award\*
  - Achieved 95% availability
- **Tampa Electric**
  - 1997 Powerplant of Year Award\*
  - First dispatch power generator



**Nation's first commercial-scale  
IGCC plants, each achieving  
> 95% sulfur removal  
≥ 90% NO<sub>x</sub> reduction**



# Clean Coal Power Initiative

- 10-year program
- 4 rounds of solicitations
- Drivers
  - Overall
    - Clear Skies Initiative
    - Reduced carbon intensity
    - Zero emissions technology target
    - Energy/economic security
  - Round 1 (Broad)
    - Advanced coal-based power generation
    - Efficiency, environmental & economic improvements
  - Round 2 (Prioritized)
    - Gasification
    - Hg control



# CCPI Demonstration Projects

## Technologies, Locations and Cost Share

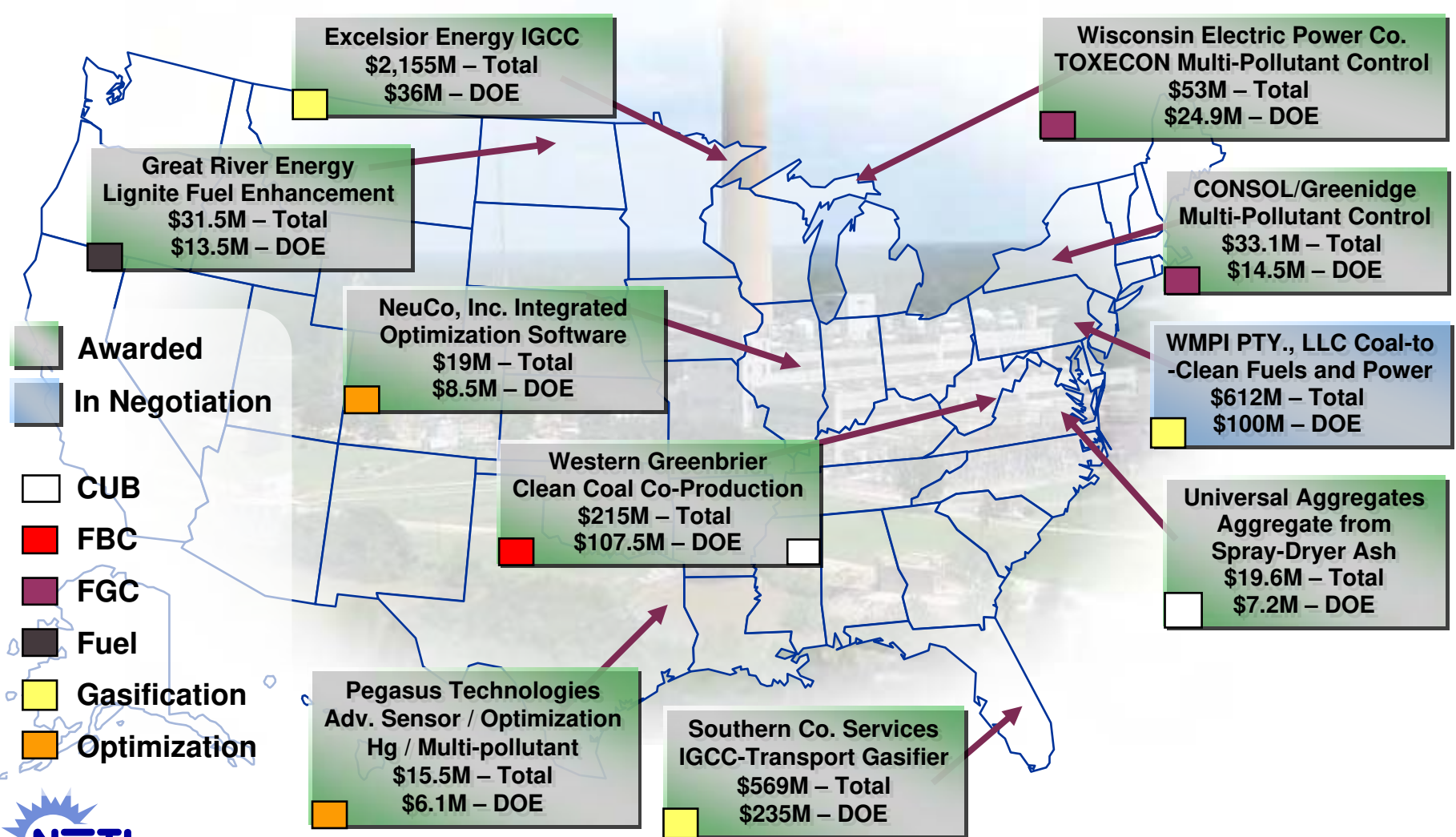

# FutureGen: A Global Partnership Effort

One-billion dollar, 10-year project to create world's first coal-based, zero-emission electricity and hydrogen plant

*President Bush, 27 February 2003*

- Research platform to accelerate deployment of promising technologies
- Broad participation from mining and electricity sectors
- 12 member industry-led consortium with international collaboration



# FutureGen Concept

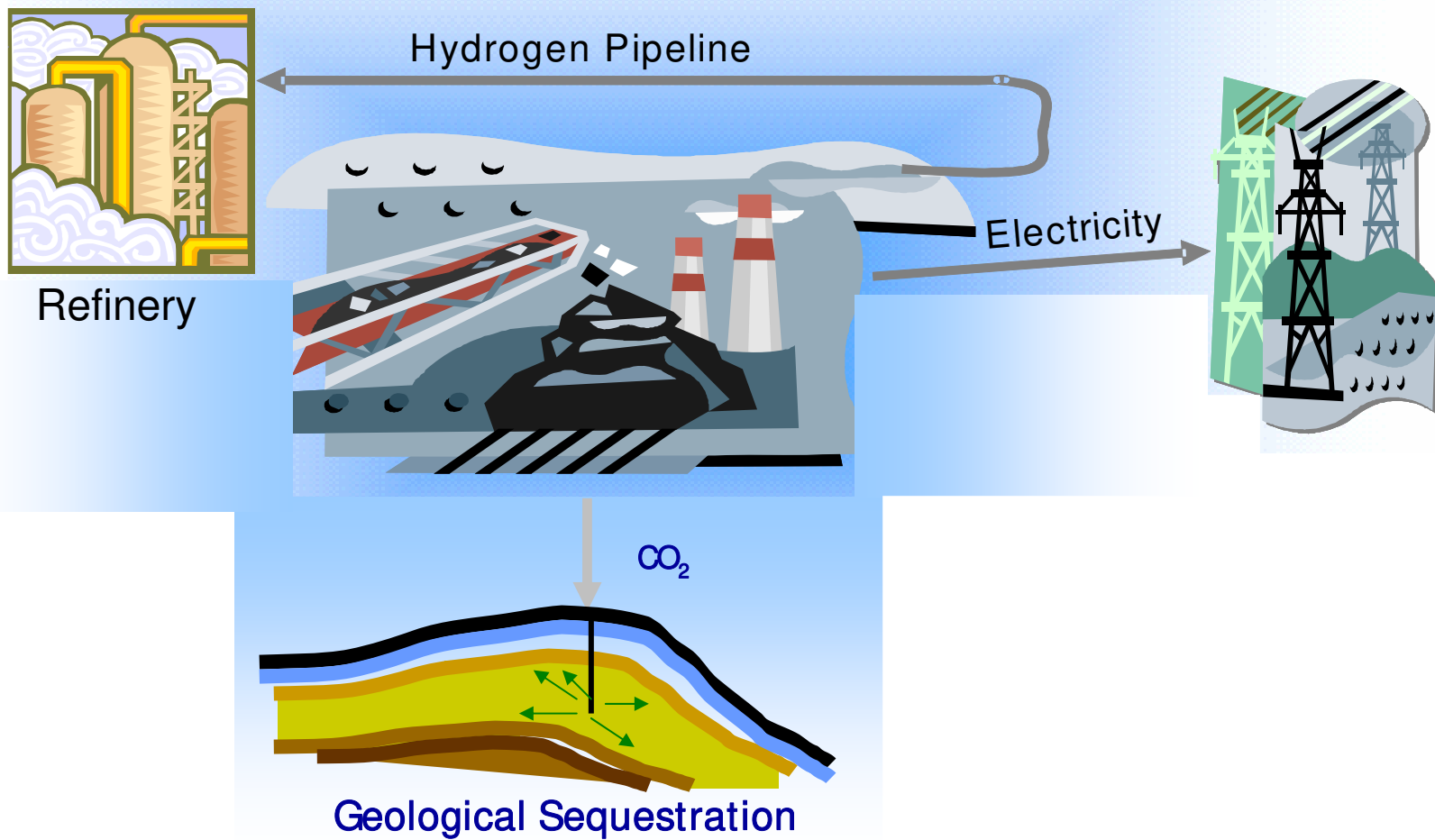



# FutureGen: Integrating Function for Fossil Energy R&D Program



**Fuel Cells**



**FutureGen**



**Carbon Sequestration**



**Gasification with Cleanup Separation**



**H<sub>2</sub> Production**



**Optimized Turbines**



**System Integration**



# FutureGen Project

## *Supporting FutureGen is Major Goal of FE's R&D Programs*

- **Industry-led project with government oversight & international participation**
  - Signed Cooperative Agreement with DOE on 2 Dec. 2005
  - Project structuring to Jan. 2007
  - Design to July 2009
  - Construction to July 2012
  - Operations to July 2016
  - Site monitoring to July 2018
- **International Participation:**
  - India and South Korea signed Protocols of Intent to join
  - China and Japan expressed strong interest in joining
- **Industry will choose project site & backbone technologies**
  - Down selected to 4 potential sites



# U.S. Government Commitment to Clean Energy From Coal

## FY 2006 Coal Program Funding

Program	Thousand \$
FutureGen	17,820
Clean Coal Power Initiative	49,500
Innovations for Existing Plants	25,146
Gasification	55,886
Turbines	17,820
Sequestration	66,330
Fuels	28,710
Fuel Cells	61,380
Advanced Research	52,622
<b>TOTAL COAL</b>	<b>375,214</b>

## Historic and Continued U.S. Support

- More than \$20 billion over past 30 years
- FutureGen: \$1 billion through 2018
- Carbon Sequestration: \$450 million through 2016





# Energy Policy Act of 2005 (EPAct) and Coal

Seven areas directly affect coal-related technologies:

Title IV, Subtitle A  
**Clean Coal  
Power Initiative**  
\$1.8bn, 2006-2014

Title IV, Subtitle B  
**Clean Power Projects**  
Grants, Loans,  
Loan Guarantees,  
and Cost Sharing  
\$ Indeterminate

Title IV, Subtitle C  
Coal and Related  
Programs  
**Clean Air Coal Program**  
\$3.0bn, 2007-2013

Title XIII Subtitle A  
**Electricity Infrastructure  
Credit for Investment in  
Clean Coal Facilities**  
\$1.65bn in tax credits

**Accelerated amortization**  
for new air pollution  
control equipment;  
\$ Indeterminate

Title XIII Subtitle B:  
Domestic Fossil Fuel Security  
**Production tax credits**  
for unconventional  
fuels, incl. CTL  
\$ Indeterminate

Title IX, Subtitle F  
Fossil Energy  
**Research  
and Development**  
\$1.137bn 2007-2009

Title XVII  
**Incentives for  
Innovative  
Technologies**  
Loan guarantees  
for gasification projects  
\$ Indeterminate

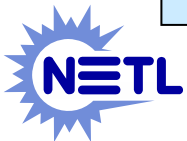

# Progress Towards Advanced Technology Implementation

- **Congressional Tax Credit Authorization of \$1.65 Billion**
- **22 applications were received**
  - representing \$27.7 billion in proposed projects
  - requesting \$2.3 billion in tax credits
  - 18 IGCC and 4 adv. coal-based generation projects
- **First Round Awards of Approximately \$1 Billion**

## First Round Recipients Include:

**Duke Energy - Edwardsport IGCC Project,**  
Edwardsport, IN

**Tampa Electric Company,** Polk County, FL

**Southern Company - Mississippi Power Company,** Kemper County, MS

**Duke Energy - Cliffside Modernization Projects,** Cleveland and Rutherford County, NC

**E.ON U.S., Louisville Gas and Electric and Kentucky Utilities Co.,** Bedford, KY

**Carson Hydrogen Power, LLC - Carson Hydrogen Power Project,** Carson, CA

**TX Energy, LLC - Longview Gasification and Refueling Project,** Longview, TX



A satellite-style image of Earth, showing the Americas (North and South America) in the center, surrounded by the Atlantic and Pacific Oceans. The image is set against a black background. The text is overlaid on the image in a bold, yellow font with a black outline.

**Support for technology development is one of Government's tools to ensure a sustainable, secure, and affordable energy future.**

# Visit Our Websites

ABOUT DOE | ORGANIZATION | NEWS | CONTACT US

U.S. DEPARTMENT OF ENERGY

SCIENCE & TECHNOLOGY | ENERGY SOURCES | ENERGY EFFICIENCY | THE ENVIRONMENT | PRICES & TRENDS | NATIONAL SECURITY | SAFETY & HEALTH

FOSSIL ENERGY

Clear Coal & Natural Gas Power Systems  
Carbon Sequestration  
Hydrogen & Other Clean Fuels  
Oil & Natural Gas Supply & Delivery  
Natural Gas Regulation  
U.S. Strategic Petroleum & Other Oil Reserves

IN YOUR STATE

SEARCH

Office of Fossil Energy

Fossil Energy

FOSSIL ENERGY NEWS SPOTLIGHT

DOE Continues Series of LNG Public Education Forums  
The third in a series of Department of Energy-sponsored public education forums on liquefied natural gas has been scheduled for Thursday, June 1, 2006, at the Los Angeles Convention Center in Los Angeles, California. Read more »

STRATEGIC PETROLEUM RESERVE CONTRACTOR RECEIVES THE BALMAGE AWARD  
Vice President Cheney presented OryMcDonough Petroleum Operations Company, operator of DOE's Strategic Petroleum Reserves, with the 2005 Halcon Balmage National Quality Award. They earned the honor, in large part, for their outstanding performance in moving crude oil to the market in response to the devastation of Hurricanes Katrina and Rita. Read more »

*Fossil Energy website:*  
[www.fe.doe.gov](http://www.fe.doe.gov)

National Energy Technology Laboratory

NETL

THE ONLY U.S. NATIONAL LABORATORY DEVOTED TO FOSSIL ENERGY TECHNOLOGY

ABOUT NETL  
WHAT WE DO & MANAGE  
ENERGY RESEARCH  
TECHNOLOGY  
NETL NEWS & ANNOUNCEMENTS  
CAREERS & FELLOWSHIPS  
NEWSROOM  
CONTACT US

Tackling U.S. Energy Challenges

Secure and Reliable Energy  
Domestic coal, oil, and natural gas resources can contribute significantly to our Nation's economic strength, energy security, and quality of life through the 21st century.

2005 NETL Accomplishments Report  
We are pleased to announce the release of NETL's 2005 Accomplishments Report, a summary of the result of NETL's work over the past fiscal year.

A Clarification: In order to ensure that the public is presented a clear understanding of the U.S. Department of Energy's perspective on the current status of mercury control technologies for coal-fired power plants and their associated costs, DOE/NETL, in cooperation with the Air Pollution Control Technology Council, has issued the subject clarification to the IPCC's April 18 press release that U.S. Department of Energy Says Mercury Control Technology Available. Click Link: Exports Urges Legislature to Praise Pennsylvania's

NEWS & FEATURES  
- Preliminary Economic Assessment of Fully Scale Carbon Capture PCP-A Study  
- Submission for "Energy Security & Commercially Feasible Assessment of CO2 Capture & Separation for Existing & Future Carbon Based Electric Generation Power Plants"  
- Submission for "Clean Coal Technologies Enable Petroleum Refactor Technology Commercial Development"  
- NETL is the general NETL coordinator in our available Gas Coal Conversion Study

EVENTS CALENDAR  
- 2006 International Technical Conference on Coal Utilization & Fuel Systems  
- 2006 International Coalbed Methane Symposium  
- Symposium on Oil-Field Services 2006  
- Society of Petroleum Engineers 2006 Annual Technical Conference & Exhibition  
- 2006 Environmental Science Conference

PUBLICATIONS &

*NETL website:*  
[www.netl.doe.gov](http://www.netl.doe.gov)





# **The UK Energy Research Atlas: A Tool for Prioritising and Planning Energy R&D**

**Risø International Energy Conference 2007  
Energy Solutions for Sustainable Development**

**22-24 May 2007**

Jim Skea, Research Director

**UKERC**

# UK Energy Research Atlas

- **Why?**
- **What?**
- **Who and how?**
- **What next?**

# ENERGY RD&D IN THE IEA

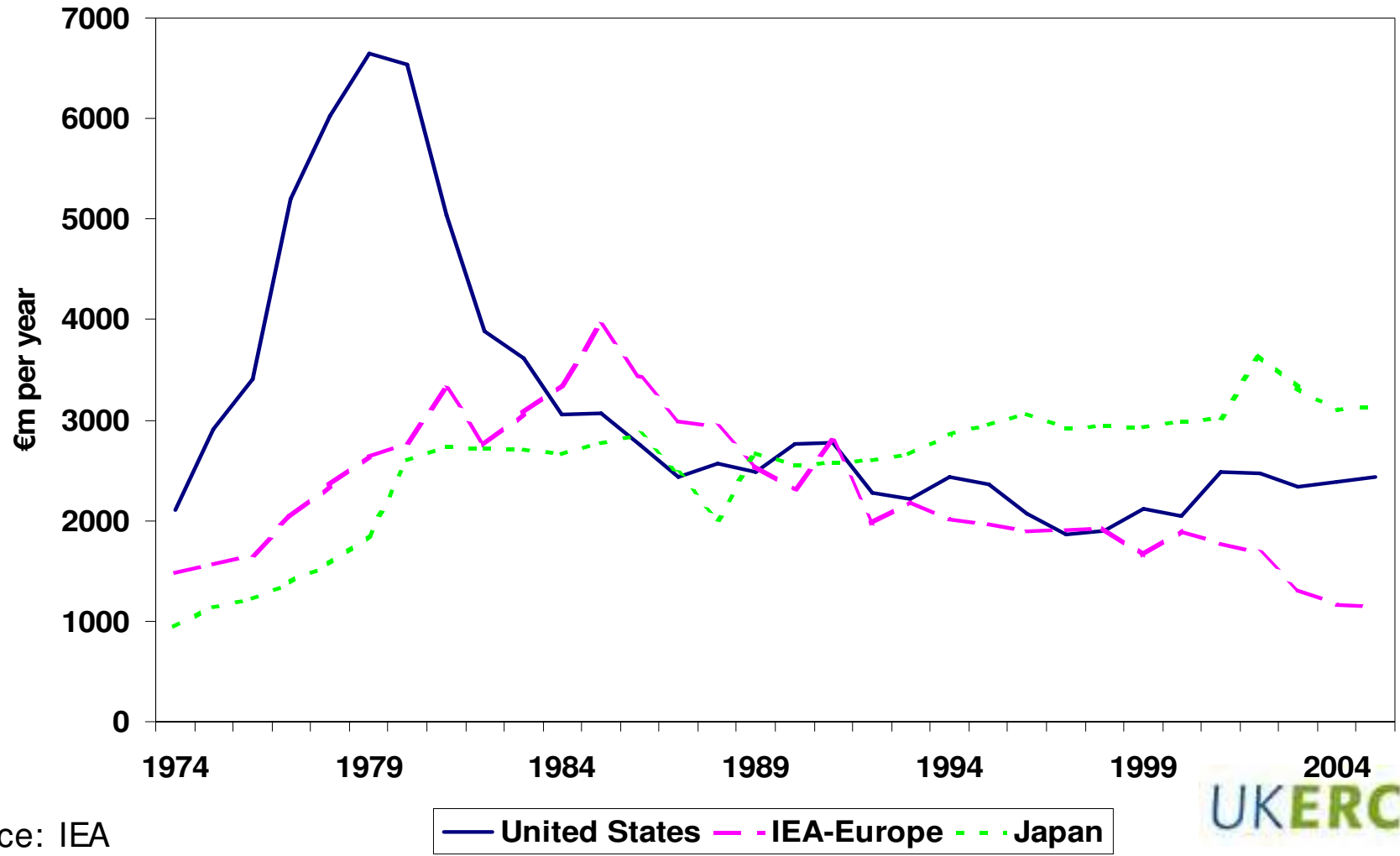

Source: IEA



# UK ENERGY R&D SINCE 1992

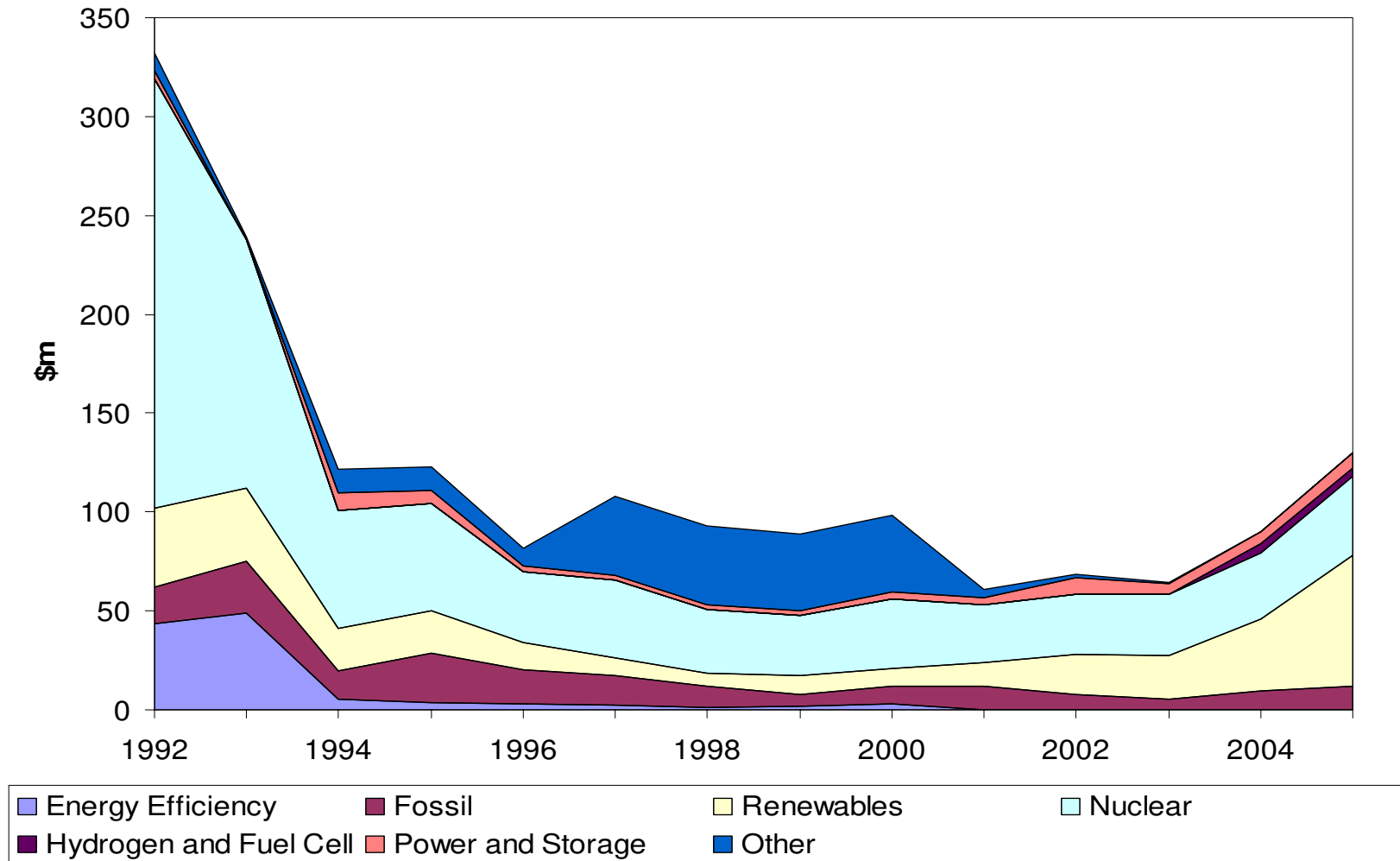

Source: IEA



# Scope

Scope of Atlas

Research

Development

Demonstration

Deployment

Research Council funded/  
University led

Government funded/  
industry led

Government/  
Devolved Administrations  
/ RDAs

OUT  
OF  
SCOPE

UKERC

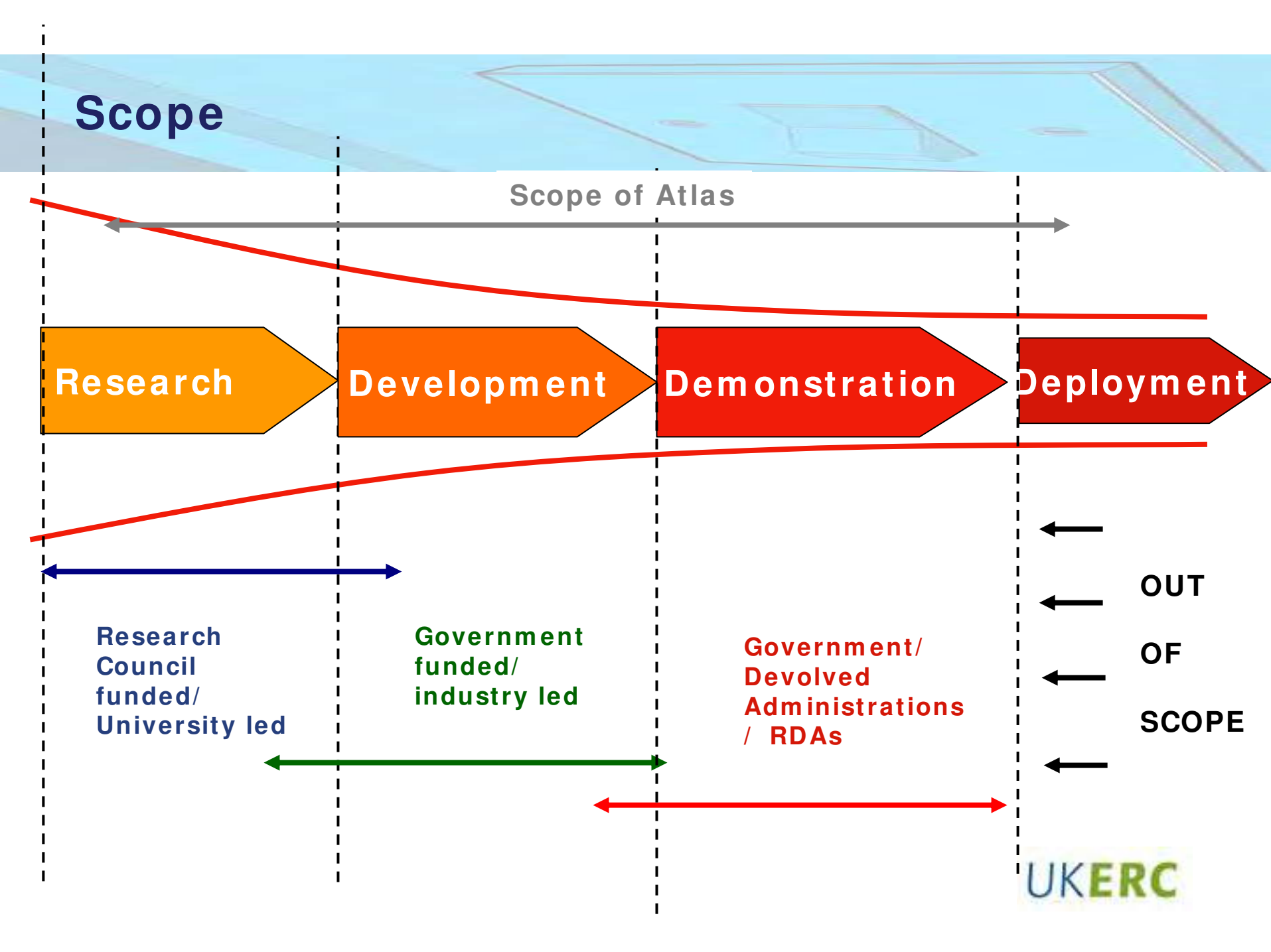

# ENERGY R&D IN THE UK

- Over-arching
  - Energy Research Partnership, little resource. Thinks about the “big picture”
- University-led
  - Research Councils Energy Programme (£70m pa), including UK Energy Research Centre (£3m pa)
- Applied R&D
  - Department of Trade and Industry Technology Programme
  - Various specific clean energy schemes
  - Energy Technologies Institute, not yet up and running (up to £100m pa, on target for £60m pa)
- Demonstration/Deployment
  - Environmental Transformation Fund, not yet up and running, resources unclear

# Why?

- **Evidence base**
- **Finding research partners/ providers**
- **Locating your own position**
- **Links along innovation chain**
- **UK and EU/ international links**

The first tool to show the live status of energy R&D in the UK

# What?

“an authoritative and comprehensive account of capabilities and unsolved research problems across the energy domain”

## Research Landscape

characterising energy-related research activities and capabilities in the UK

## Research Register

an online, searchable database of energy-related awards and projects

## Research Roadmaps

identifying the sequence of research problems to be overcome before new technologies can be commercially viable

# IEA R&D Nomenclature

- **Energy demand**
- **Fossil fuels: oil, gas and coal**
- **Renewable energy sources**
- **Nuclear fission and fusion**
- **Hydrogen and fuel cells**
- **Other power and storage**
- **Other cross-cutting technologies and research**

# Accessing the Landscapes

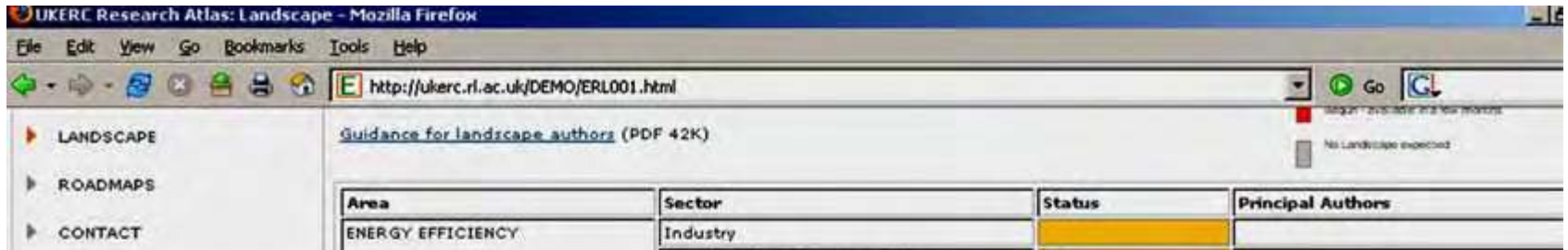

## Structure

- Overview
- Capabilities Assessment
- Basic and Applied Strategic Research
- Applied Research
- Development and Demonstration Funding
- Research Facilities and other Assets
- Networks
- UK Participation in EU Activities
- International Initiatives

Area	Sector	Status	Principal Authors
ENERGY EFFICIENCY	Industry	Orange	
	Residential and Commercial	Orange	
	<u>Transport</u>	Green	Dr Jillian Anable, Robert Gordon University
OIL, GAS and COAL	Oil and Gas	Grey	
	Coal	Red	
	CO2 Capture and Storage	Orange	
RENEWABLE ENERGY SOURCES	<u>Solar Energy</u>	Green	Prof David Infield, University of Loughborough
	Wind Energy	Red	
	<u>Ocean Energy</u>	Green	Dr Markus Mueller, University of Edinburgh
	<u>Bio-Energy</u>	Green	Prof Gail Taylor, University of Southampton
	Geothermal Energy	Grey	
	Hydropower	Grey	
	Other Renewables	Grey	
NUCLEAR and FUSION	<u>Nuclear Fission</u>	Green	Dr Paul Howarth, Dalton Institute, University of Manchester
	<u>Nuclear Fusion</u>	Green	Dr David Ward, UKAEA
FUEL CELLS	<u>Hydrogen</u>	Green	Dr Geoff Dutton, CCLRC
	<u>Fuel Cells</u>	Green	Prof Nigel Brandon, Imperial College London
ELECTRICITY STORAGE	Electric power conversion	Grey	
	<u>Electricity transmission and distribution</u>	Green	Dr Joseph Mutale, University of Manchester
	Energy storage	Grey	
SYSTEMS INTEGRATING RESEARCH	<u>Energy system analysis</u>	Green	Dr Neil Strachan, Policy Studies Institute
	Environmental, social and economic impacts	Grey	



# Research Funders and Providers

Bioenergy\_Section3.pdf (application/pdf Object) - Mozilla Firefox

File Edit View Go Bookmarks Tools Help

http://ukerc.rl.ac.uk/Landscapes/Bioenergy\_Section3.pdf

Save a Copy Select 72% Search Web Y! Adobe

Layers Pages Attachments

**Table 3.2: Key Research Providers**

Name	Description	Sub-topics covered	No of staff	Field
<a href="#">Forest Research, Forestry Commission, Edinburgh and Alice Holt, Surrey</a>	Research on modelling yield in SRC bioenergy trees, biofuel as a source of renewable energy and GHG balance of bioenergy cropping systems.	<ul style="list-style-type: none"> <li>• SRC Yield Models in development</li> <li>• Woodfuel as a resource</li> <li>• Member of TSEC-BIOSYS</li> <li>• Climate change programme to predict the effects of future climates on woodfuel resource in the UK. Environmental sustainability.</li> <li>• Policy development and advice to central Government.</li> </ul>	4 Principal Investigators	Agriculture
<a href="#">School of Biological Sciences, University of Aberdeen</a>	School of Biological Sciences is actively engaged in research on the GHG mitigation potential of bioenergy crop systems	<ul style="list-style-type: none"> <li>• GHG mitigation and carbon balance of bioenergy crop systems.</li> <li>• Member of TSEC-BIOSYS Environmental sustainability</li> </ul>	2 Faculty	Biological Sciences
<a href="#">Sustainable Environment Research Centre, University of Glamorgan</a>	Two research units - the Wastewater Treatment Research Unit and the Hydrogen Research Unit. The aims are to produce high quality scientific research in the field of sustainable environment in particularly acting as an umbrella body for the Wastewater Treatment Research Unit and the newly approved Hydrogen Research Unit; to advance knowledge and provide trained scientists and engineers to meet the needs of industry; to enhance the standing of the University of Glamorgan both nationally and internationally.	<ul style="list-style-type: none"> <li>• Expertise in dark fermentation reactions for hydrogen production</li> <li>• Member of TSEC-BIOSYS consortium</li> <li>• Member of SUPERGEN Fuel cells consortium</li> <li>• Member of the SUPERGEN Sustainable hydrogen economy consortium</li> <li>• Expert in biohydrogen production including anaerobic and aerobic digestion.</li> </ul>	7 Faculty	Biological Sciences
<a href="#">Institute of Grassland and</a>	Focus is on breeding and	<ul style="list-style-type: none"> <li>• Coordinator of DEFRA crop</li> </ul>	3 Principal Researchers	Biological Sciences

# Searching the Register

UK ENERGY RESEARCH CENTRE

Research Register : Public Access

▶ UKERC HOME

▶ REGISTER HOME

▶ SEARCH THE REGISTER

▶ CATEGORY LIST

▶ RESEARCH ATLAS

▶ CONTACT REGISTER  
MANAGER

[Home](#) | [Research Register](#) | [Public Interface](#) | [Search for Grant Details](#) | [List of Grants Found](#) | [DUPLICATE](#)

**Reference Number** GR/S26965/01

**Title** UK Sustainable Hydrogen Energy Consortium

**Status** Started

**Energy Categories** HYDROGEN and FUEL CELLS(Hydrogen, Hydrogen production) 10%;  
HYDROGEN and FUEL CELLS(Hydrogen, Hydrogen storage) 70%;  
HYDROGEN and FUEL CELLS(Hydrogen, Hydrogen transport and distribution) 5%;  
HYDROGEN and FUEL CELLS(Hydrogen, Other infrastructure and systems R&D) 5%;  
HYDROGEN and FUEL CELLS(Hydrogen, Hydrogen end uses (incl. combustion; excl. fuel cells)) 10%;

**Research Types** Basic and strategic applied research 100%

**Science and Technology Fields** PHYSICAL SCIENCES AND MATHEMATICS (Chemistry) 60%;  
PHYSICAL SCIENCES AND MATHEMATICS (Metallurgy and Materials) 20%;  
SOCIAL SCIENCES 20%;

**UKERC Cross Cutting Characterisation** Not Cross-cutting 90%;  
Sociological economical and environmental impact of energy 10%;

**Principal Investigator** **Dr T Mays**  
[T.J.Mays@bath.ac.uk](mailto:T.J.Mays@bath.ac.uk)  
Chemical Engineering  
University of Bath

**Award Type** 3

**Funding Source** EPSRC

**Start Date** 01 April 2003

**End Date** 31 March 2007

**Duration** 48 months

**Total Grant Value** £3,481,041

**Industrial Sectors** Environment; Power

**Region** South West

**Programme** Infrastructure and Environment

**Investigators** **Principal Investigator** [Dr T Mays](#), Chemical Engineering, University of Bath (99.981%)  
**Other Investigator** [Dr R Dingsdale](#), Sch of Applied Sciences, University of Glamorgan (0.001%)  
[Professor P Edwards](#), Oxford Chemistry, University of Oxford (0.001%)  
[Dr J Gameson](#), School of Chemistry, University of Birmingham (0.001%)  
[Professor DM Grant](#), Sch of Mech, Materials, Manuf Eng & Mgt, University of Nottingham



# Technology Roadmap Characterisation

## Bibliographic

- weblink, geographical focus, abstract

## Outputs

## Architecture

- timescales, trends and drivers, enablers, performance targets, rd&d mapping, critical assessment of capabilities

## Process

- methods, stakeholder engagement, scale, re-visiting

## Actions identified

- types, timescales, priorities, dependencies, responsibilities

# Who Contributed and How?

**UKERC researchers**

**Rutherford Appleton Labs**

**Partners:**

- UKAEA
- Dalton Institute
- Energy Helpline, UK National Contact Point
- British Coal Utilisation Research Association

**Atlas Advisory Group**

- UKERC plus Carbon Trust, DTI, Environmental Research Funders Forum, E.ON UK, EPSRC, Office of Science and Innovation

# How It's Been Used

- background information for presentations on the UK energy research
- information on local activities for regional development authorities etc
- evidence supporting criteria for the work programme of the new Energy Technologies Institute
- patterns of research activity for the International Science Panel on Renewable Energy
- identifying partners for establishing consortia for EU Framework Programme bids.

# What Next?

**The Research Atlas will never be finished....**

## **Immediate Tasks**

- **Peer review/ community feedback**
- **Fill in missing Landscape/ roadmap sectors**
- **Synthesise existing roadmap information**
- **Content management system/ database development**

## **Longer Term**

- **6 monthly review cycle**
- **Enhance international dimension**
- **Private sector**
- **Address sectors not covered so far**
- **New UK-relevant roadmaps where the need exists**



[www.ukerc.ac.uk](http://www.ukerc.ac.uk)

UKERC

## ***European and global perspectives for CCS***

Martine Uyterlinde, Heleen Groenenberg

*Risø International Energy Conference, May 22 2007*



## Models and partners

- MARKAL ECN, Netherlands
- PRIMES/PROMETHEUS ICCS/NTUA, Greece
- MESSAGE IIASA, Austria
- POLES IPTS, Spain
- GMM PSI, Switzerland
- PACE ZEW, Germany
- TIMES-EE, NEWAGE-W IER, Germany
- NEMESIS ERASME, France
- ETP IEA, France
- NEMS DOE/EIA, US
- DNE21+ RITE, Japan
- AIM NIES, Japan
- MAPLE Natural Resources Canada

# CASCADE-MINTS

	<i>Top down</i>		<i>Bottom up</i>	
	Macro-economic	Computable General Equilibrium	Energy System Optimisation	Integrated Energy System simulation
Global, US, Canada		AIM* NEWAGE-W PACE*	DNE21+ ETP GMM MESSAGE PROMETHEUS (stochastic)	POLES NEMS MAPLE*
Europe	NEMESIS*		MARKAL Europe TIMES-EE	PRIMES*



# CO<sub>2</sub> capture and storage

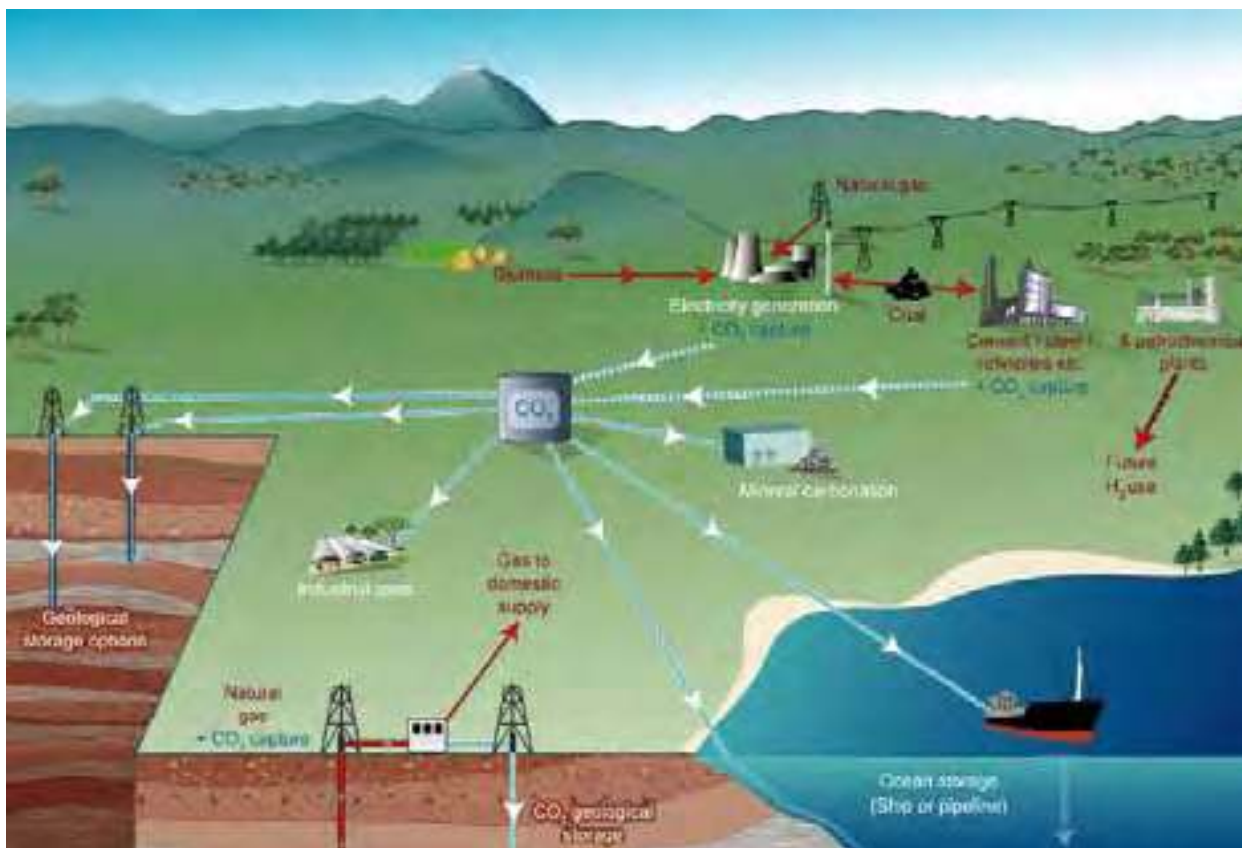

IPCC 2005

## CCS in models

- Post combustion (pulverized coal, NGCC)
- Pre combustion (IGCC, biomass gasification)
- No oxyfuel
- Some: H<sub>2</sub>, cement, cokes, ammonia
- Wide variety of storage options *or*
  - 1 generic technology with infinite capacity

## CCS in models (ctd.)

Varying assumptions on:

- Investment costs
- O&M costs
- Energy penalty
- Capture efficiency
- Learning rate

No assumptions on:

- Public acceptance
- Risks and safety regulations

## Two policy approaches

- **CCS standards:**
  - CO<sub>2</sub> capture obligation all new plants >2015
  - not for peaking plants (<10 MW or utilisation < 20%)
  - not for small CHP
- **CO<sub>2</sub> emission cap:**
  - emission level same as CCS standards
  - emissions trading only

## CO<sub>2</sub> emission cap

- Emission level same as CCS standards
- Flexibility in technologies used
- Lower costs
- Lower penetration CCS
- More renewables and nuclear
- Shift to natural gas

# CCS standards case

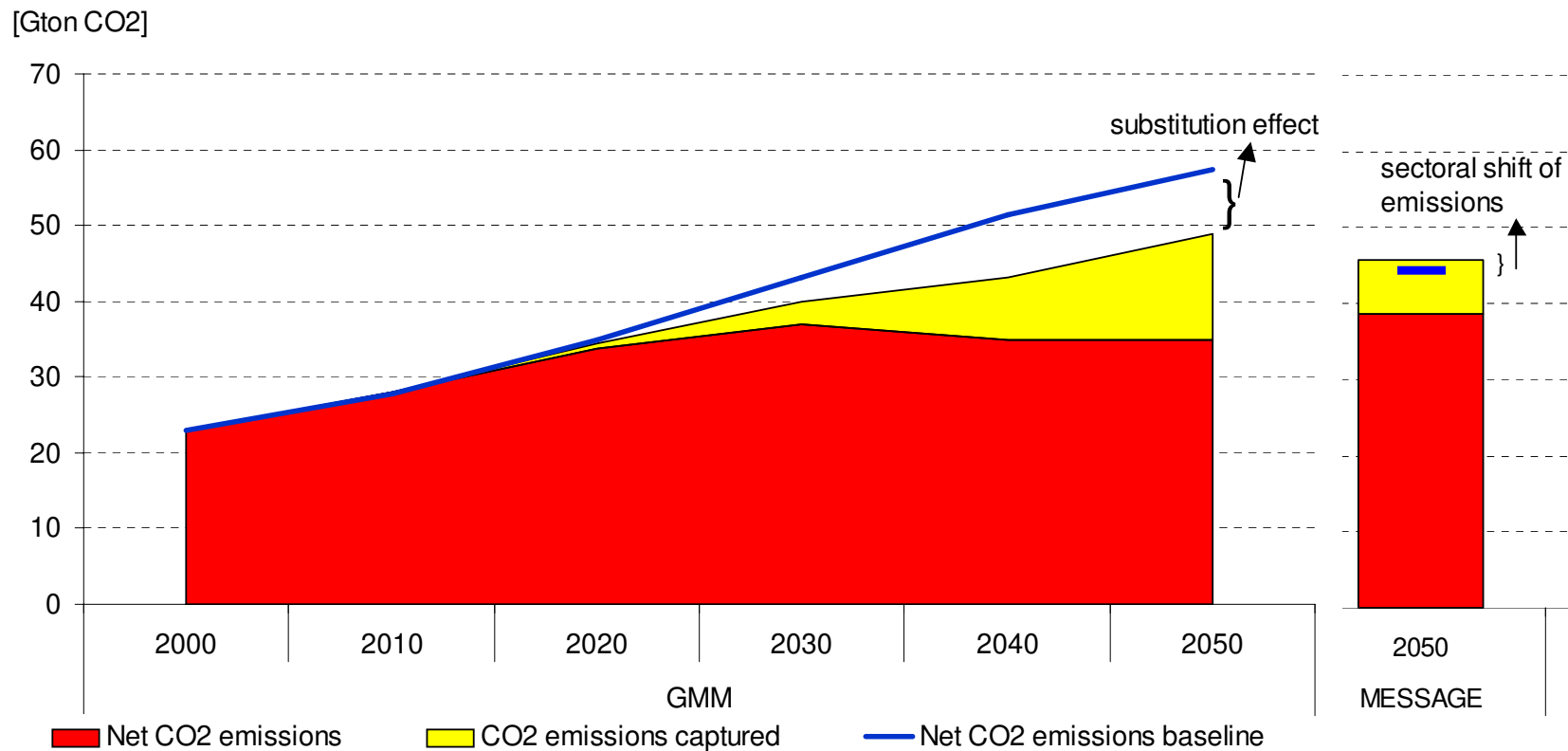

## CCS standards (ctd.)

- 16-30% of global CO<sub>2</sub> captured in 2050 (7-19 GtCO<sub>2</sub>)
- 21-23% of total CO<sub>2</sub> captured in Europe
- Variation due to differences in:
  - projections primary energy mix
  - assumptions technology learning
  - future costs capture and renewables
  - potentials renewables, constraints nuclear

## CCS standards (ctd.)

- Large capacities w/o CCS remain in system
- Peak gas capacity and renewables gain most
- Substitution effect: nuclear and renewables more competitive (> energy penalty)
- CCS may lead to leakage of emissions to other sectors (MESSAGE), e.g. biomass in power or more H<sub>2</sub> from fossil fuels
- Coal-based CCS dominates, esp IGCC
- Biomass gasification negative emissions but high capital costs



# CO<sub>2</sub> storage capacity

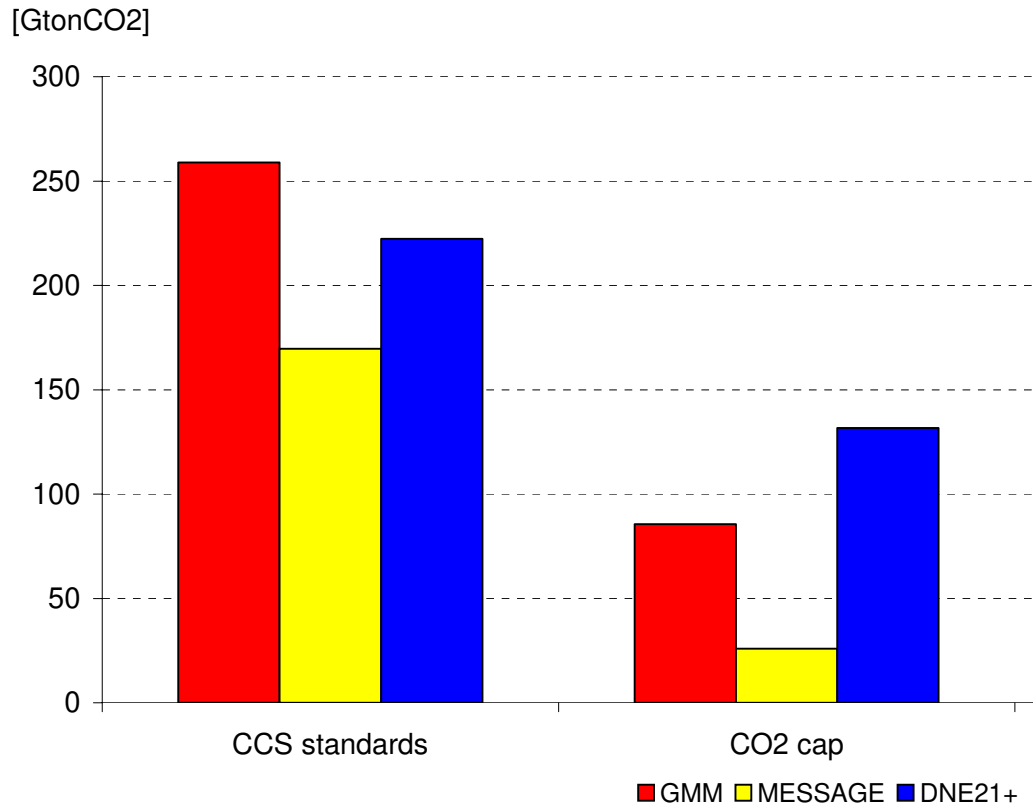

- IPCC 1995: 675-900 GtCO<sub>2</sub> in depleted hydrocarbon fields

# CO<sub>2</sub> storage capacity (ctd.)

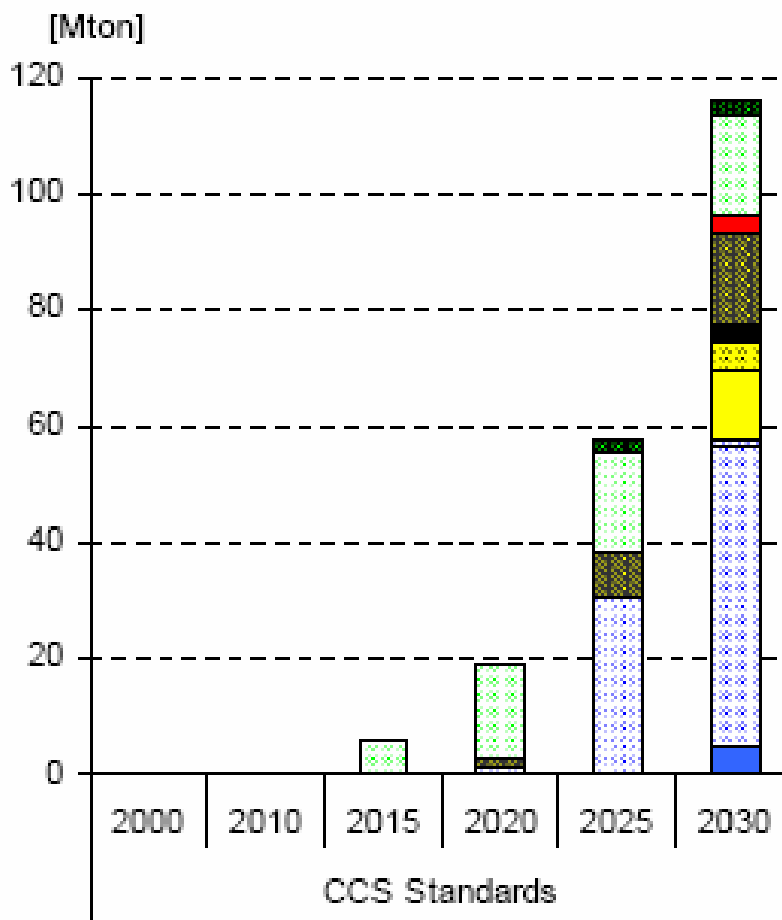

-  Slovenia
-  Hungary
-  Poland
-  Slovakia
-  Czech Republic
-  Sweden
-  Spain
-  Portugal
-  Netherlands
-  Italy
-  Greece
-  Germany
-  Denmark
-  Belgium

*TIMES EE*

## EU Emissions Trading Scheme

- Cost-effective instrument, however:
- Preference for low-cost abatement options
- Innovation market failure
- Need for complementary policies

## Complementary incentives for CCS

- CCS obligation
- Low-carbon portfolio standard + tradable certificates
- Public financial support
  - Investment support
  - Feed-in subsidies
  - CO<sub>2</sub> price guarantee

# Interaction complementary incentives ↔ ETS (ctd)

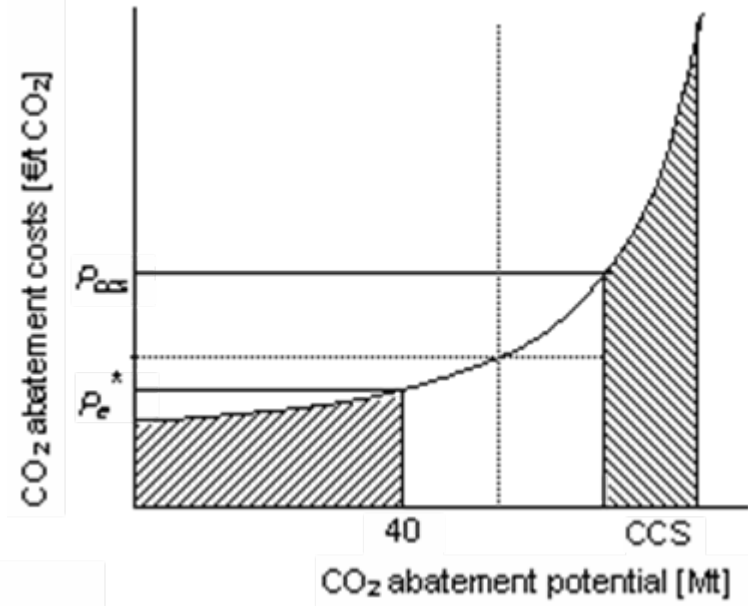
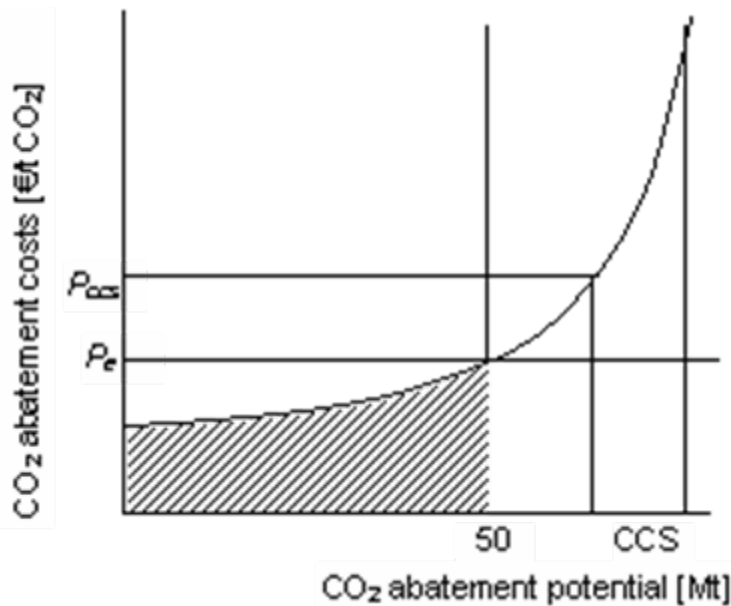

Any additional instrument will reduce demand for EUAs and lower CO<sub>2</sub> market price *unless* cap is lowered accordingly

## Interaction complementary incentives ↔ ETS (ctd)

- MS incentives small scope; less market impact
- *Any* additional instrument will reduce demand for EUAs and lower CO<sub>2</sub> market price *unless* cap is lowered accordingly

→ *Lower cap in MS*

→ *New entrants: no or limited allowances*

# Interactions complementary incentives for CCS

Renewable energy:

Diversion of resources + attention

→ % renewables contingent on CCS implemented

Innovation:

Cost reduction discouraged

→ *Obligation*

Electricity market:

Technical reasons for placing CCS as baseload option,  
however O&M cost lead to higher electricity price

Security of energy supply:

CCS only contributes if gas prices spur a shift to coal, and  
CO<sub>2</sub> prices are high enough for CCS

## Conclusions

- Up to 30% of global CO<sub>2</sub> captured and stored in 2050
- Up to 22% in Europe (slower growth power sector)
- Penetration renewables and nuclear accelerated if CCS is mandatory
- ETS cost-effective incentive for CO<sub>2</sub> reduction, however market failures and low prices may hinder CCS deployment
- Interaction of complementary incentives with ETS requires cap adjustment



# Thank you

<http://www.ecn.nl/en/ps/research-programme/energy-scenarios/cascade-mints/>

The CASCADE MINTS project is funded by the EU under the Scientific Support to Policies priority of the Sixth RTD Framework Programme

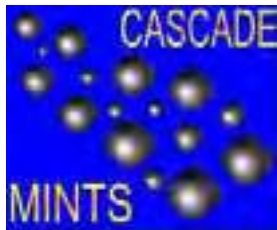

Martine Uyterlinde: [uyterlinde@ecn.nl](mailto:uyterlinde@ecn.nl)  
Heleen Groenenberg: [groenenberg@ecn.nl](mailto:groenenberg@ecn.nl)

# Solar Energy Status and Perspectives

By Peter Ahm, Director, PA Energy A/S

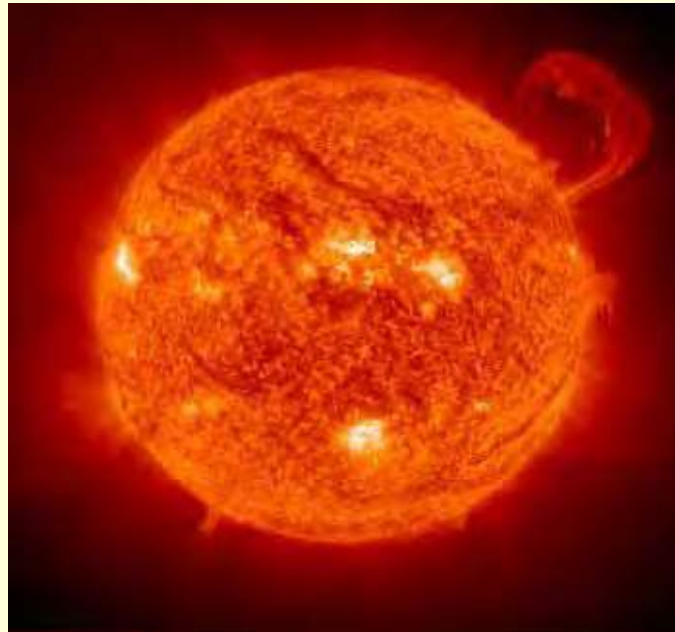

# The Potential for Solar Energy

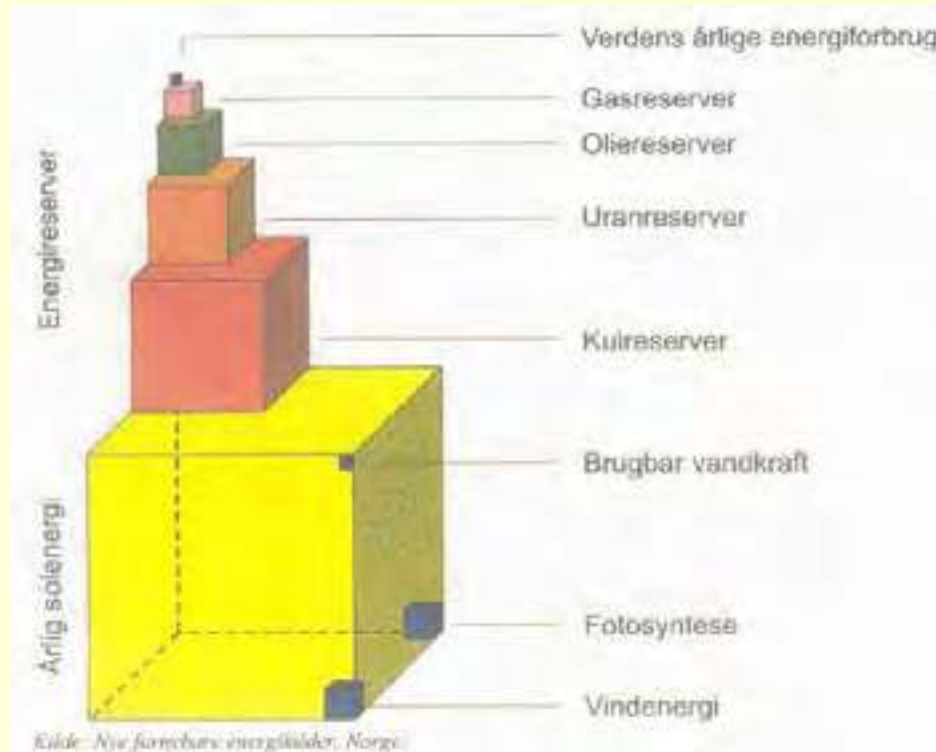

One hour's sunshine ~ the global annual energy supply

# Solar Energy in the World Energy Supply

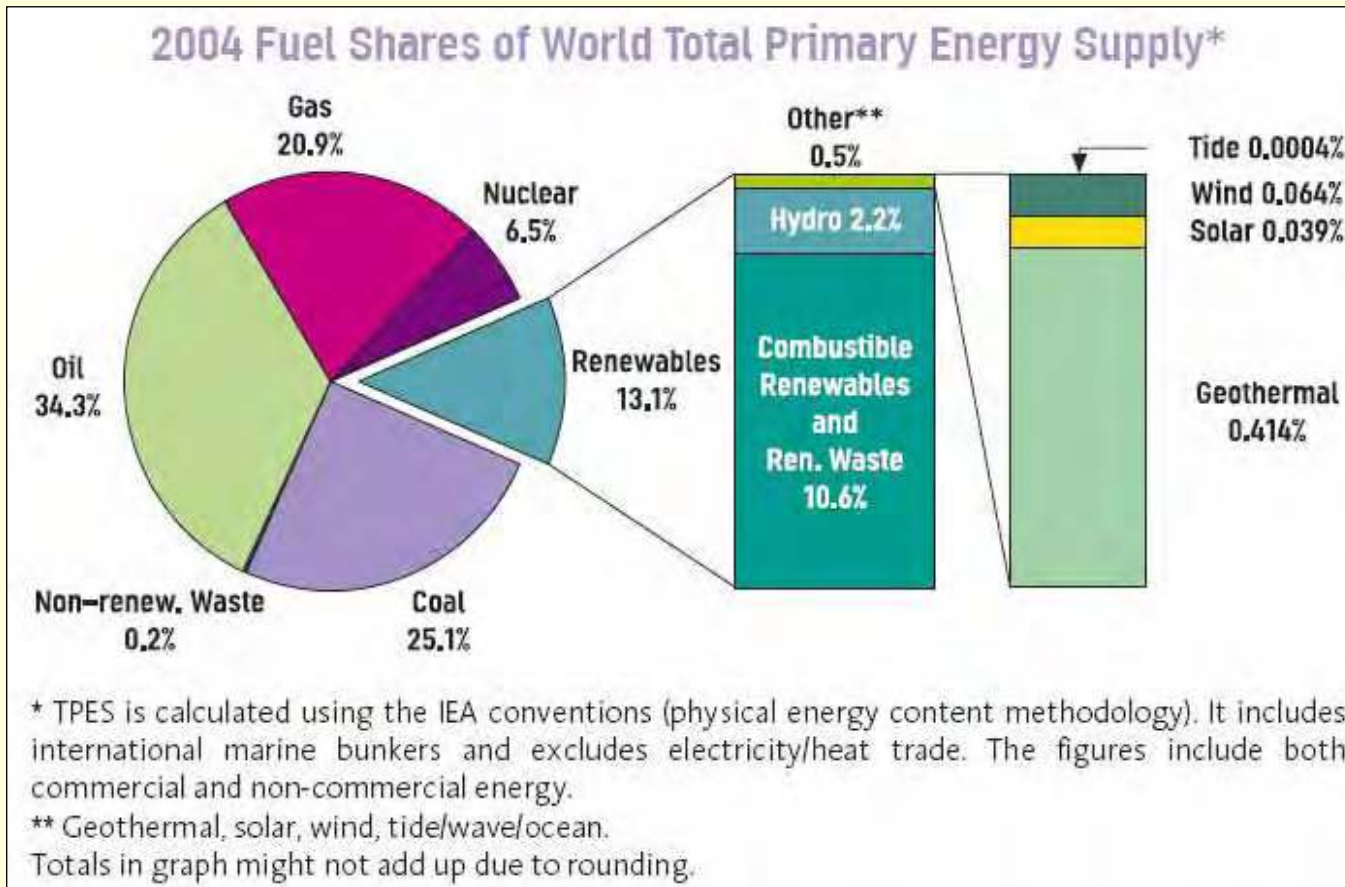

Source: IEA

# RE Characteristics

	World electricity production 2003 (TWh)	Electricity generation costs 2003 (€ cents/kWh)	World estimated technical annual generation potential (heat & electricity) ( $\times 10^3$ TWh)
Hydroelectricity	3 000	2-8	14
Bio-energy	175	5-6	77 - 124
Wind energy	75	4-12	178
Geothermal power	50	2-10	1400
Marine energy	0.5	[8-15]*	No number available
Solar thermal energy	0.8	12-18	} 440
PV	2,5	25-65	
Total	3300		>2100
	<i>Total electricity consumption: 15 000</i>		<i>Current global energy consumption: 110</i>

\* estimated costs as no commercial plant is yet in production

# RE Growth Rates

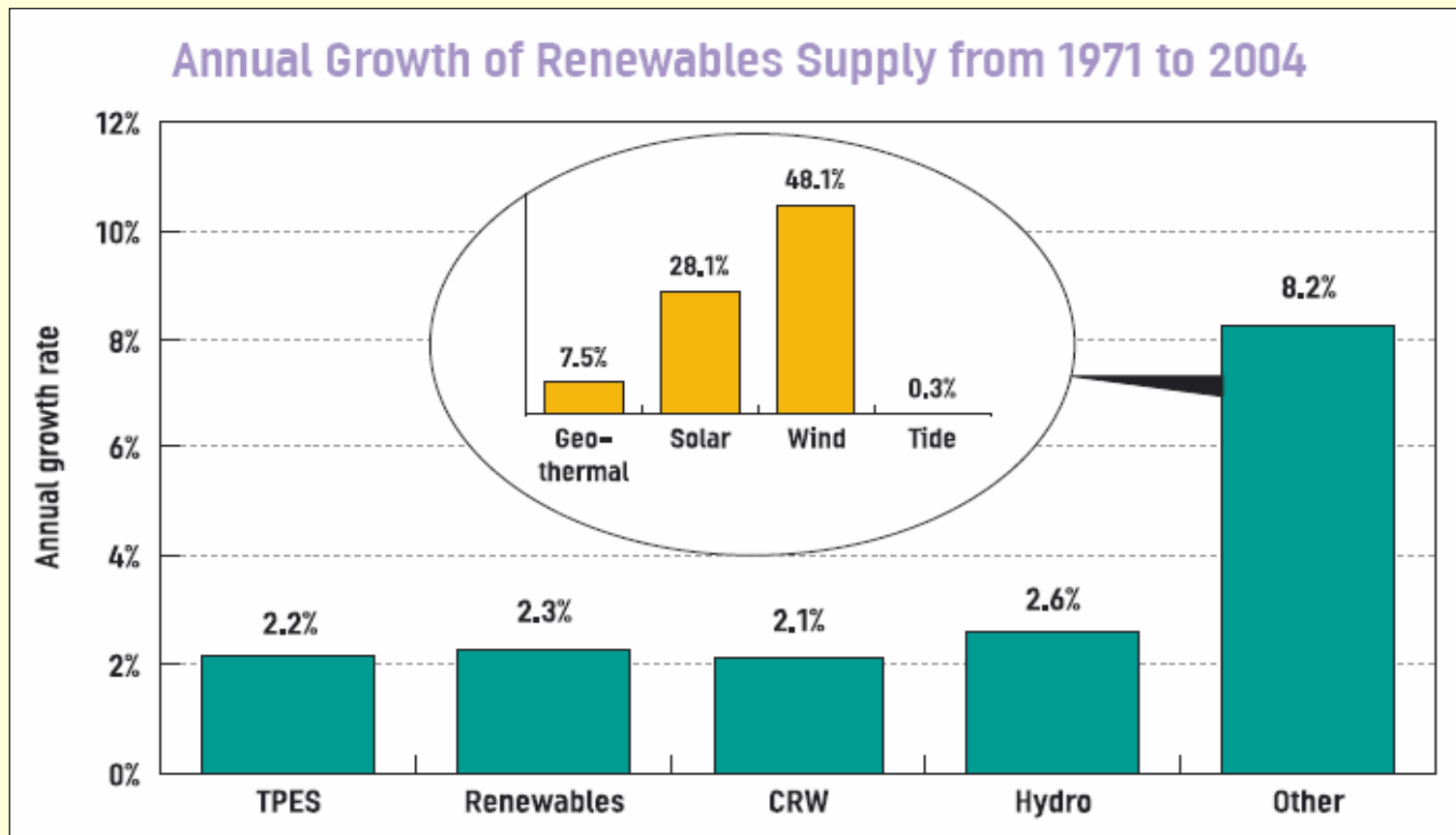

# Solar Energy Technologies

- Photovoltaics (PV) - electricity
- Solar Hot Water System (SHW)
- Concentrated Solar Thermal (CST) - electricity



# Presentation: Focus on PV

1. Status of technology
  - a) Technology development
  - b) Market development
  
2. Drivers & trends in development
  
3. Challenges, or problems, facing progress



# 1. Generation PV's

- Based on mono- og poly-crystalline Si
- In 2006 ~ 90% of the market, poly-X alone > 50 %
- Expected in 2015 to cover > 50 % of the market
- Efficiency: 15-20%
- The PV sector "work horse"



# 2. Generation PVs

- Thinfilm types
  - Si, CdT, CIS etc.
- Promising technology
  - Potentially cheap
    - Little materials
    - Mass production
- Problem
  - Manufacturing
  - Stability
- Efficiency: 7- 15 %
- Time horizon: + 2010



# 3. Generation PVs

- High-efficiency thinfilms
  - stacked types: 30-60 % efficiency
  - PEC types
  - Polymer based types
- Time horizon: more than 15 years for commercial products (PEC on the market)



# PV Technology Trends

Trends in market share per main PV technology

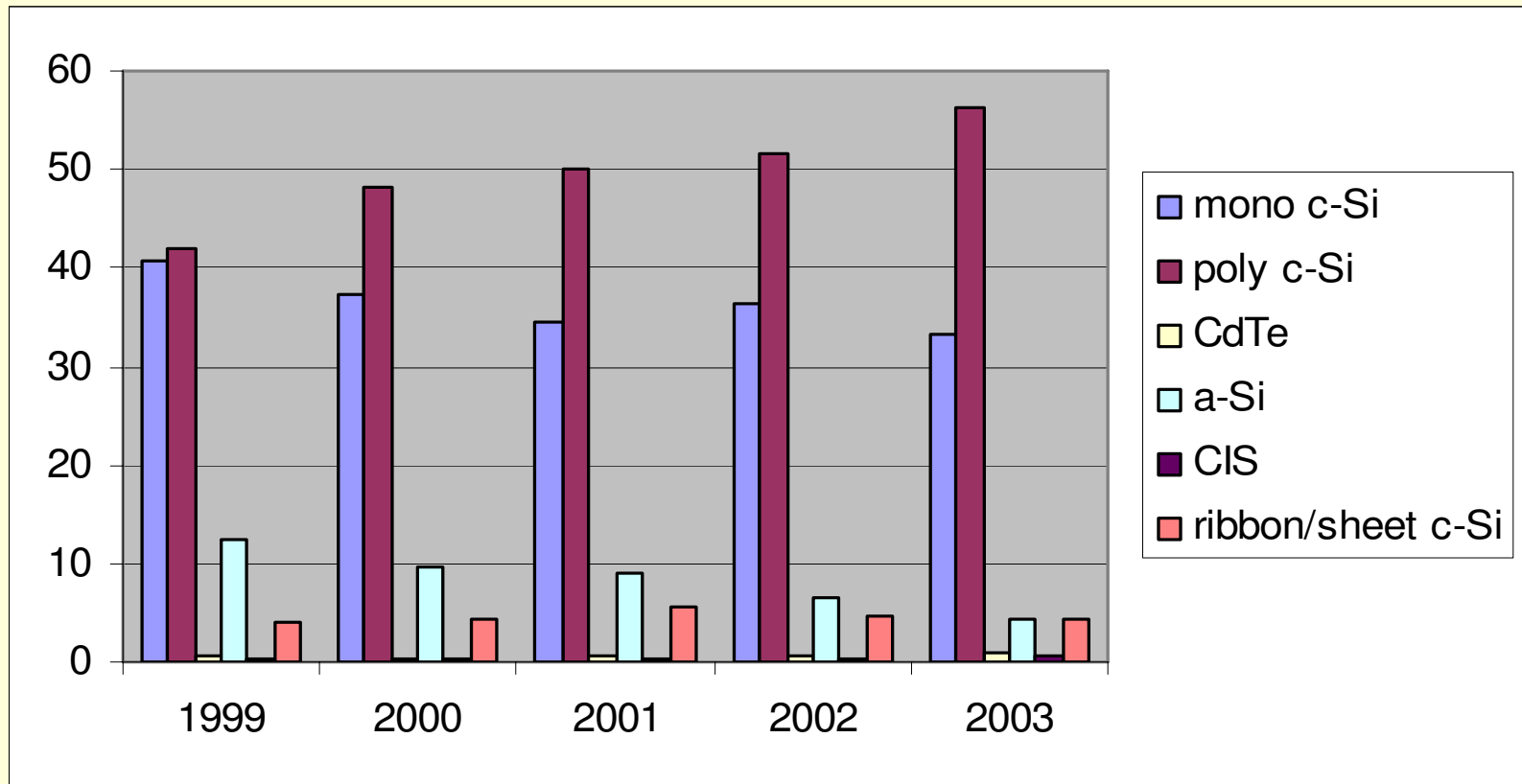

# Market Development 1

- Annual growth rate since 2000 around 40 %
- Market value (global): >15 billion € (as wind energy)
- Cell production in 2006: 2,5 GW
- Expected module production in 2010: ~ 6-8 GW)

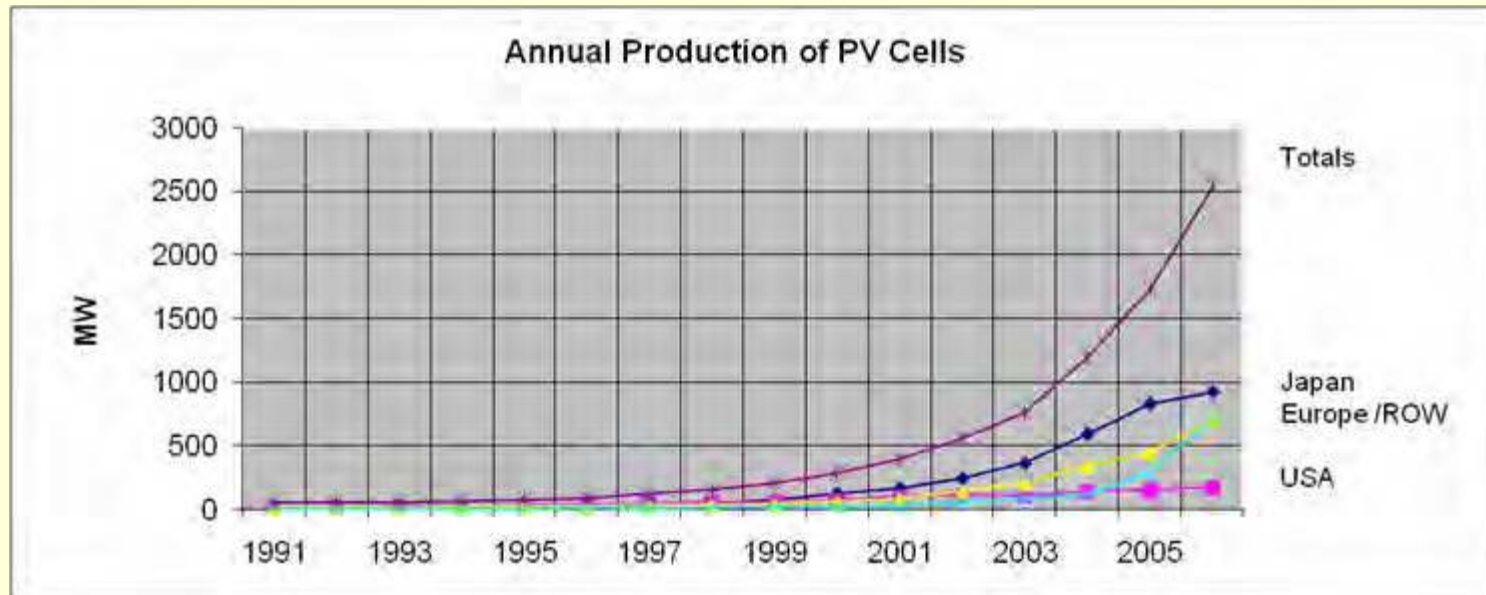



# Market Development 2

## Annual growth rates in %

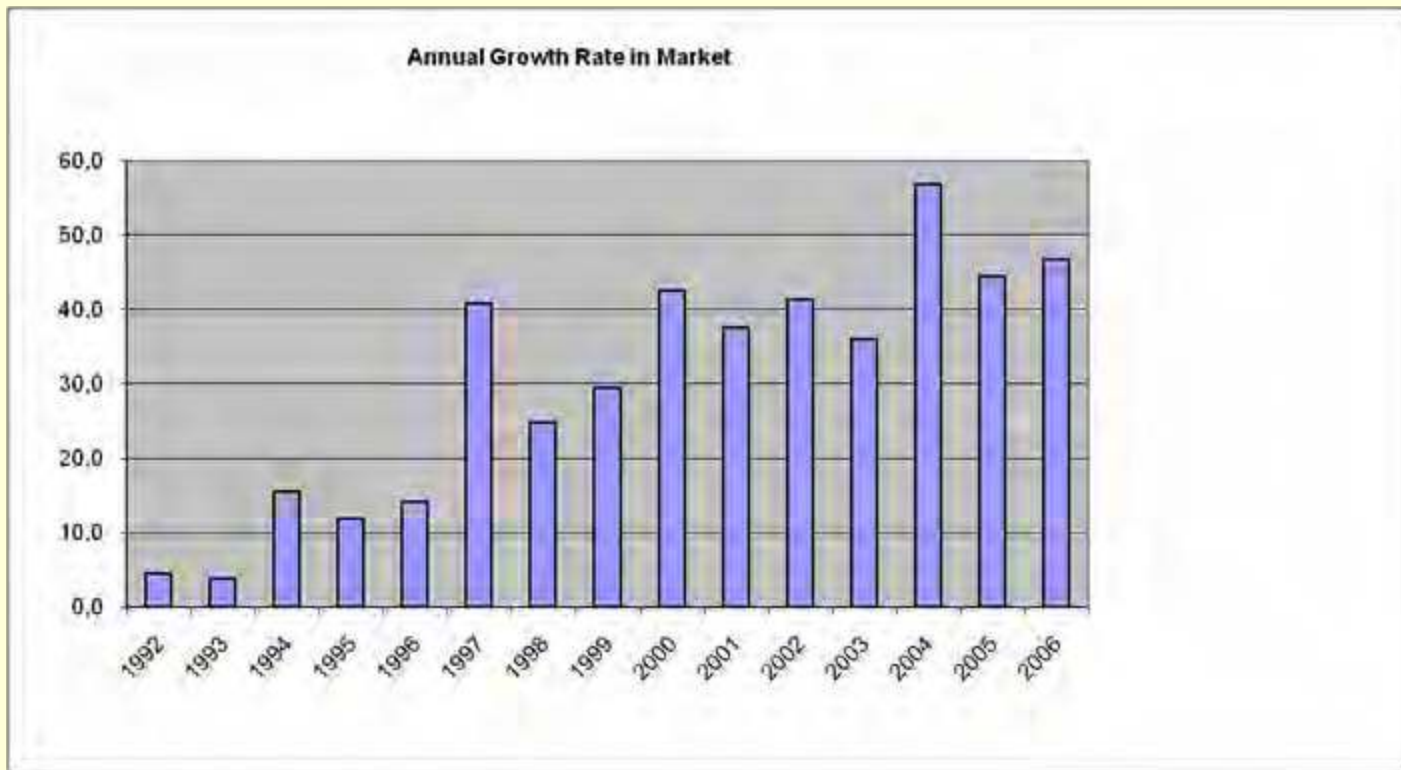

# Trends in Efficiency

Reported max.  $\eta$ : 37 % (Emcore 2007)

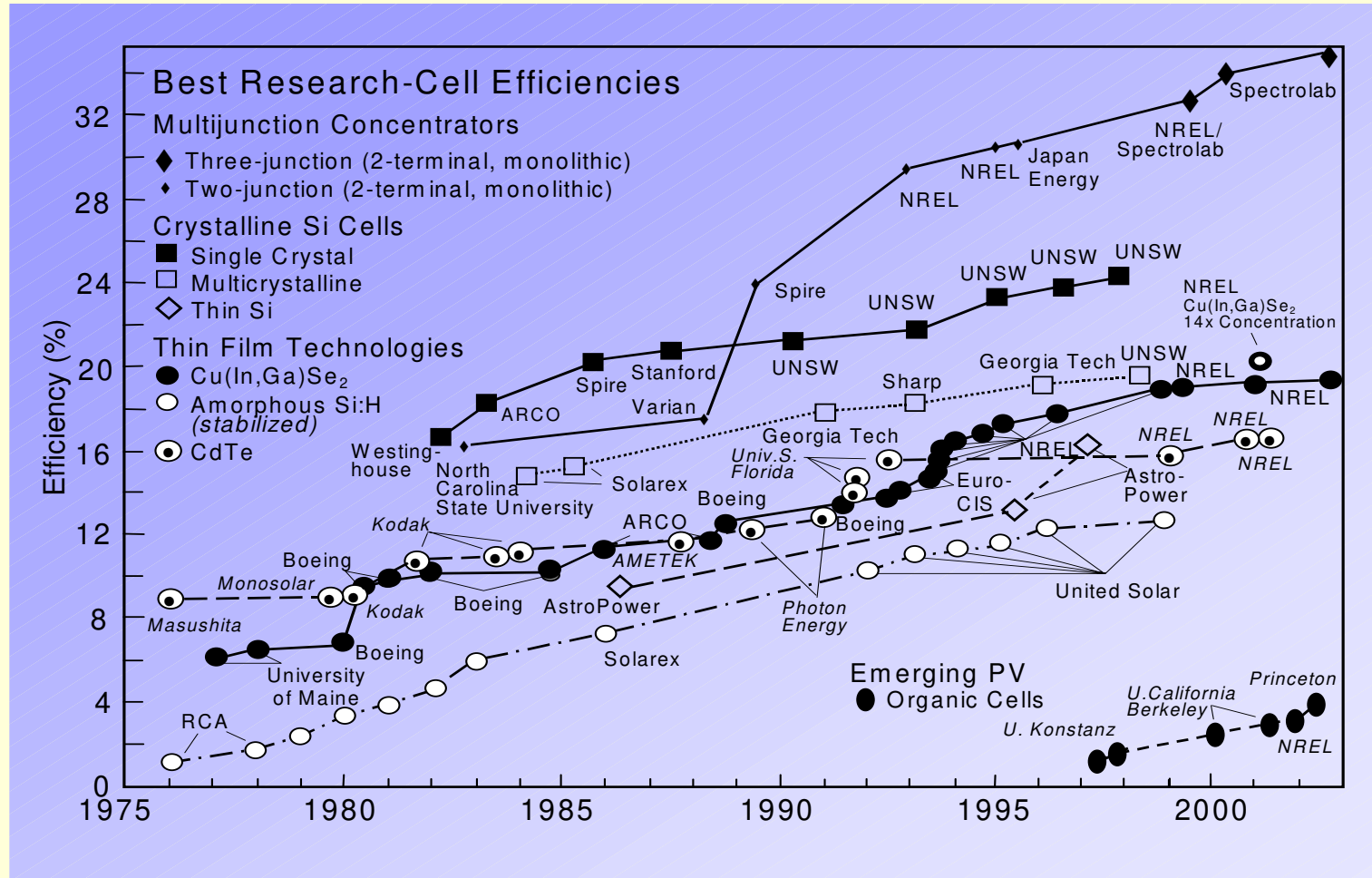

# Job Creation in Energy

**Table 3. Direct jobs in energy production.**

Sector	Jobs. year /MTOE (fuel production)	Jobs - year / Terawatt-hour (fuel production + power generation)
<b>Petroleum<sup>a</sup></b>	396	260
<b>Offshore oil<sup>a</sup></b>	450	265
<b>Natural gas<sup>a</sup></b>	428	250
<b>Coal<sup>a</sup></b>	925	370
<b>Nuclear<sup>b</sup></b>	100	75
<b>Wood energy<sup>c</sup></b>		733 – 1067
<b>Hydro<sup>d</sup></b>		250
<b>Minihydro<sup>e</sup></b>		120
<b>Wind</b>		918 <sup>(e)</sup> – 2,400 <sup>(f)</sup>
<b>Photovoltaics</b>		29,580 <sup>(g)</sup> – 107,000 <sup>(e)</sup>
<b>Bioenergy (from sugarcane)<sup>h</sup></b>		3,711-5,392

Sources: (a) Grassi [1996]; (b) Electric Power International [1995] *apud* Grassi [1996]<sup>1</sup>; (c) Grassi [1996]<sup>2</sup>; (d) Carvalho and Szwarcz [2001]; (e) Perez [2001]; (f) IEA [2002b]<sup>3</sup>; (g) REPP [2001]<sup>4</sup>, IEA [2002b]<sup>5</sup>; (h) UNICA [2003]<sup>6</sup>.

<sup>1</sup> 500 people was the staff level for operation of a 1350 MW nuclear power plant in the U.S., producing 9.45 TWh/yr (or 2.138 Mtoe/yr) at efficiency of 38%

<sup>2</sup> electric generation based on herbaceous crops (5.5 direct jobs/ MWe) and on forestry crops (8 direct jobs/ MWe), utilization 7,500 h/yr

<sup>3</sup> world installed capacity for wind 17,300 MW, utilization 2,000 h/yr and 4.8 jobs/MW

<sup>4</sup> including 12 different activities to construct, transport, install and service 1 MW of PV (not included economies of scale between 2 kW and 1 MW), world installed PV capacity is 800 MW

<sup>5</sup> utilization of 1,200 h/yr; 35.5 jobs/MW (included 15 different activities to manufacture, transport, install and service 1 MW of wind power)

<sup>6</sup> ethanol industry provides 33 direct jobs/ million liter in Brazil, where ethanol production in the 1992-2001 period ranged between 10.6-15.4 billion liters/yr (LHV of ethanol 6,500 kcal/kg and density 0.8kg/l); energy production comprised 7 Mtoe of ethanol fuel, plus 9.6 TWh/yr of cogeneration (installed capacity 2,000 MW, utilization of 4,800 hours/yr)



# Trends in PV module prices

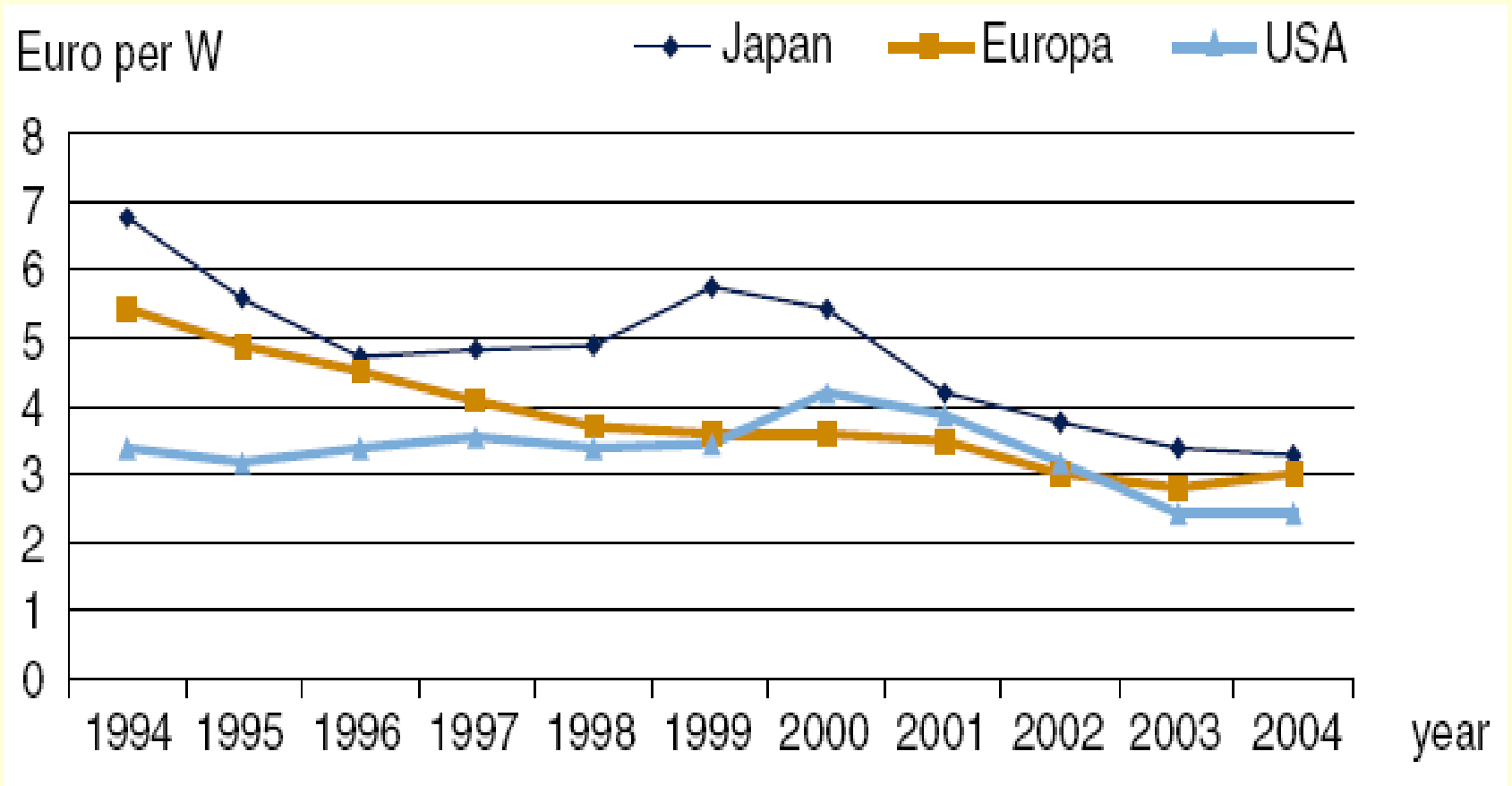

# PV Learning Curve

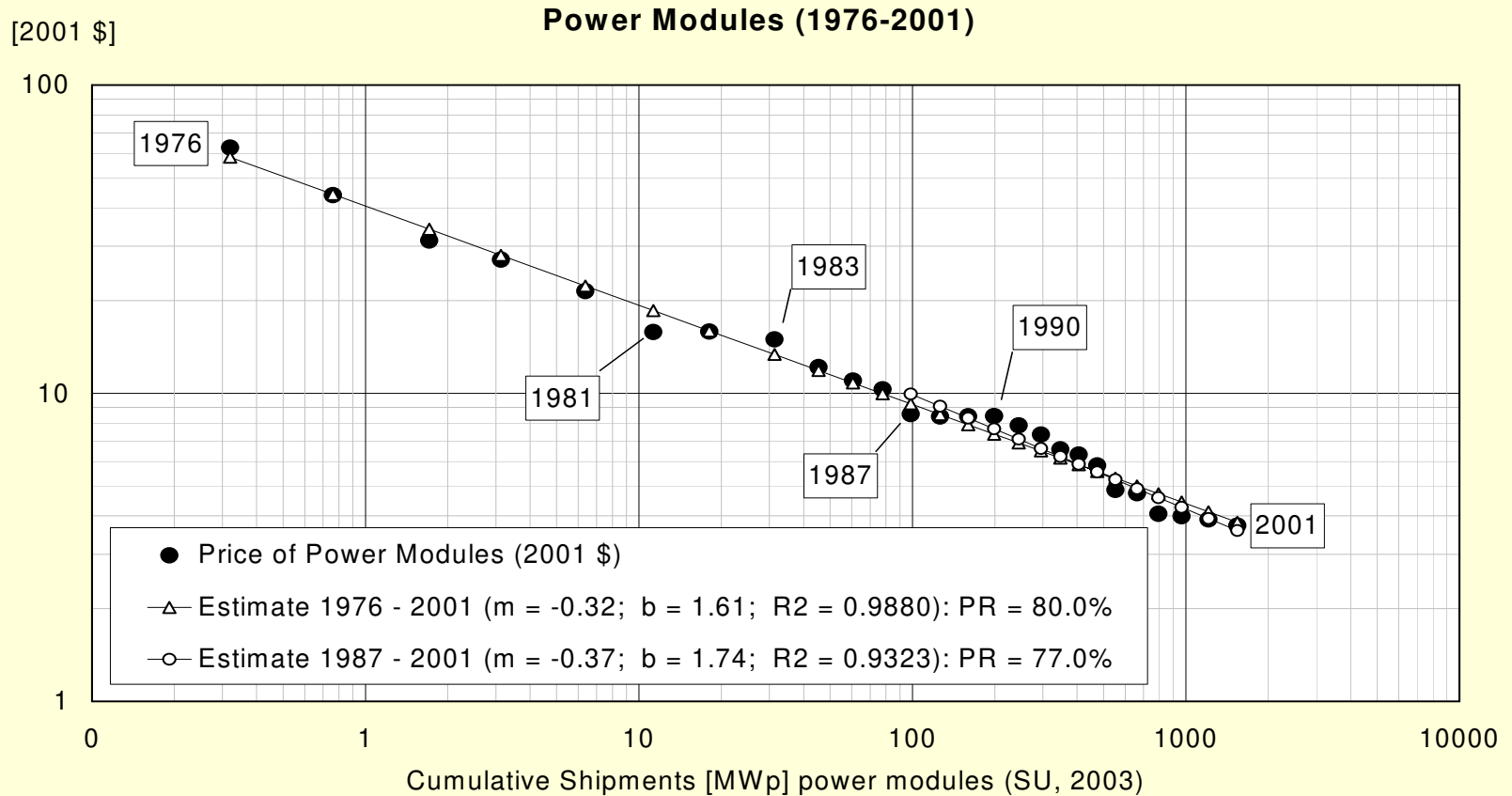

# Learning Curves – Energy Technologies

- PV is special: technology generations known

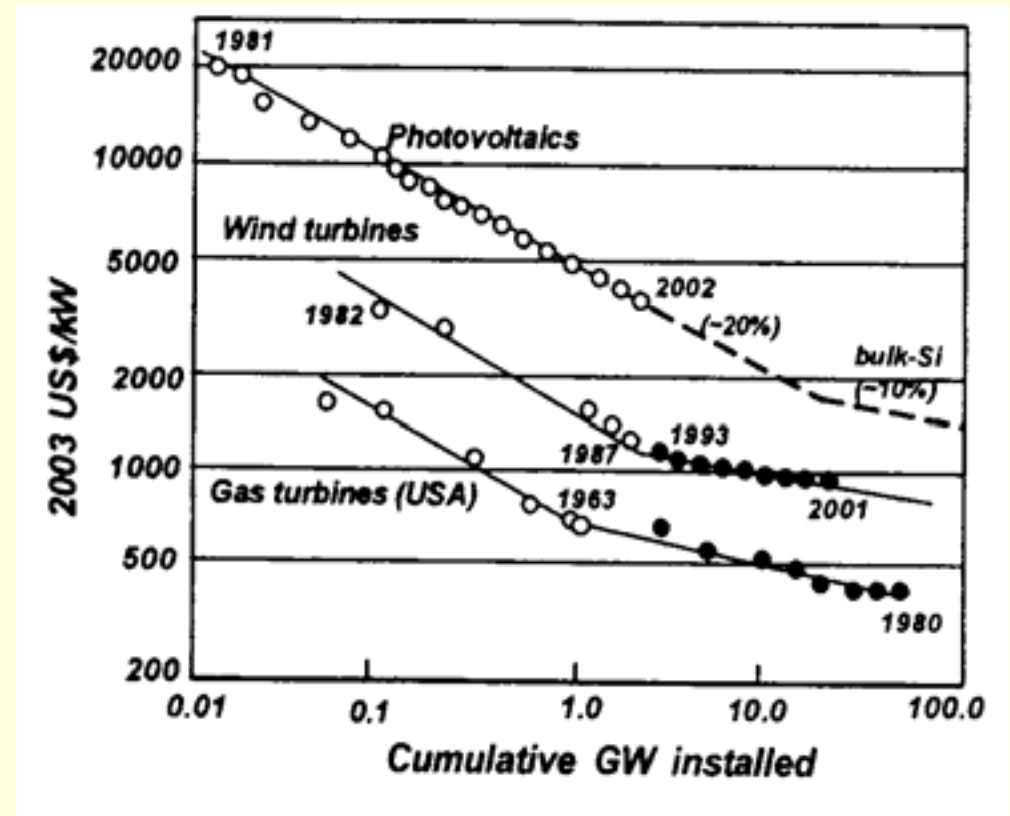

# When will PV be competitive?

- IEA (Wene 2000) productionen of PV modules shall be increased by a factor 100 before competitiveness with fossil fuels (from 300 MW/y to 30 GW/y)
- With an annual average growth rate of 30 % this is achieved in 15 years (2015)

# Competitiveness of market sectors



## Market Segments

# Competitiveness of PV Solar Electricity

- proven in the three segments:
  - industrial off-grid
  - consumer
  - rural electrification
- coming soon in grid-connected systems
  - First, in local replacement of peak tariff electricity in liberalized southern OECD countries (... 2010 ... 2015)
  - Second, the same in more northern OECD countries (... 2020 ... 2025)

# Competitiveness vs. grid power

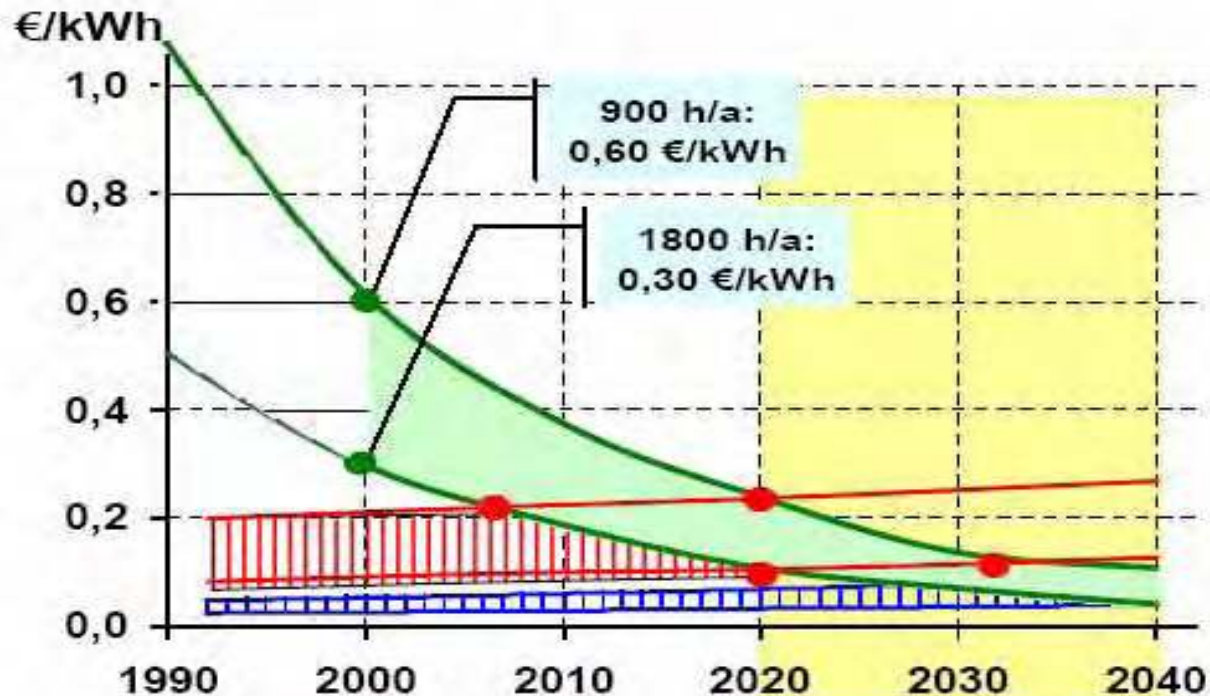

Photovoltaic Utility Peak Cost Bulk Cost

Source: EPIA towards an Effective Industrial Policy for PV.ppt/05.06.2004/Rapp @RWE Schott

# Technology Evolution

- Is there a necessity for 2nd and 3rd generation technologies to replace c-Si wafer technology for module production cost below 1 €/W ?
- **No**, but utilize new features of thin film and new concept cells to serve additional customer needs!



# Technology evolution

## 1) No 1€/W limit for c-Si modules

<b>Module full production cost [€/W]</b>	<b>MUSIC-FM APAS-RENA (1997)</b>	<b>update (2002)</b>
c-Si ribbon (e.g. EFG)	0,7	0,6
multicryst./Cz-wafer	0,9 / 1,1	0,8 / 1,0
thin-film (e.g. a-Si, CIS)	0,7	...

# Technology evolution

## EPIA Roadmap - c-Si technology

	<b>2000</b>	<b>2010</b>	<b>2020</b>
feedstock	25	20	15 €/kg
wafer	300	200	100 $\mu\text{m}$
cell	14-17	17-20	19-22 %
module	long term stable, low cost/m <sup>2</sup> technology		

In the long run integrated manufacturing of thin wafers (100  $\mu\text{m}$  or less) and subsequent cell and laminate making is probably the most effective route.

# PV Technology forecast

**Figure 5: Possible Production by Technologies in 2020 and 2030**

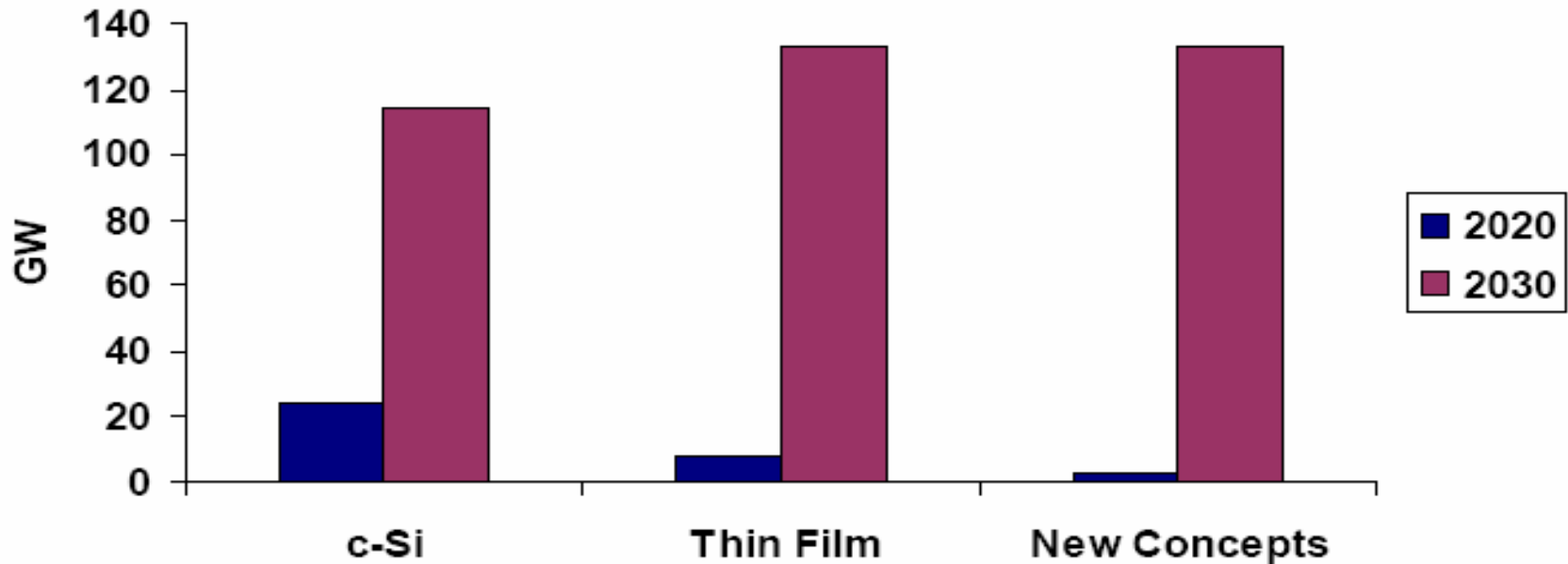

Source: Strategies Unlimited

# Visions for PV 1

**Table 2. Key cost and investment assumptions of renewables. Source: IEA, 2006**

	Learning rate (%)	Investment cost (\$/kW)			Production cost (\$/MWh)		
		2005	2030	2050	2005	2030	2050
Biomass	5	1000–2500	950–1900	900–1800	31–103	30–96	29–94
Geothermal	5	1700–5700	1500–5000	1400–4900	33–97	30–87	29–84
Large hydro	5	1500–5500	1500–5500	1500–5300	34–117	34–115	33–113
Small hydro	5	2500	2200	2000	56	52	49
Solar PV	18	3750–3850	1400–1500	1000–1100	178–542	70–325	< 60–290
Solar thermal	5	2000–2300	1700–1900	1600–1800	105–230	87–190	< 60–175
Tidal	5	2900	2200	2100	122	94	90
Wind onshore	5	900–1100	800–900	750–900	42–221	36–208	35–205
Wind offshore	5	1500–2500	1500–1900	1400–1800	66–217	62–184	60–180

Note: Using a 10% discount rate. The actual global range is wider as discount rates, investment cost and fuel prices vary. Wind and solar include grid connection cost. Learning rate implies percentage cost reduction for each doubling of installed capacity.

# Visions for PV 2

- Japan 2030:
  - 52-82 GW installed
  - 5-10 Yen/kWh
- USA 2030:
  - 25 GW installed (10 % of electricity)
  - 150.000 new jobs
- EU 2010:
  - 3 GW installed (1 % of el.) – expect. > 6 GW

# Visions for PV 3

→ Extract from the roadmap developed by representatives of industry and research at the 9th Wotterfal talks

	As at 2005	Target 2010	Target 2020
<b>Economy</b>			
Capacity produced in Germany (MWp/a)	350	1,000	12,000
Jobs in Germany	20,000	50,000	200,000
System price (grid-connected, euro/W)	4.5 – 5.5	3.6	1.5
Photovoltaic electricity costs in Germany (Cent/kWh)	45 (+/-5)	30	10
Module life (years)	20 – 25	35	35
Inverter (euro/Wp)	0.4	0.2	0.15
<b>Wafer technology</b>			
Silicon requirement (t/MW)			
• Foils	8	6	5
• Block-casting	12	10	5
Wafer thickness (µm)	250 – 300	150 – 180	100
<b>Cell efficiency in production</b>			
Wafer technology			
• Monocrystalline	16.5	20	20
• Polycrystalline	14 – 14.5	17 – 18	20
Thin film silicon	9	12	15
CIS compound semiconductor	10	14	17

# Cost & Prices

Price 2006: 0,5 US\$/kWh (OECD aver.)

Levelized cost of solar power - 2006

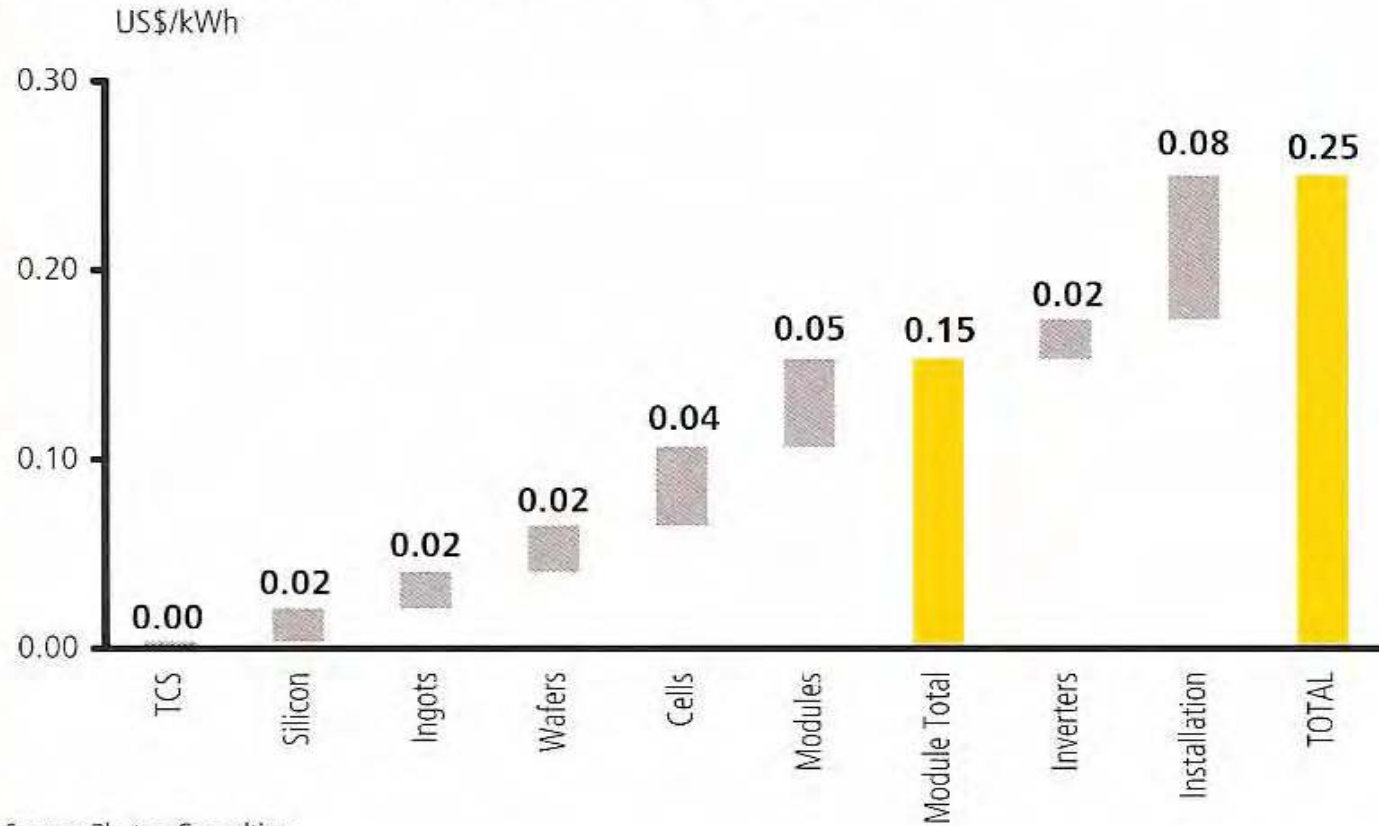

Source: Photon Consulting



# Cost Reduction Drivers

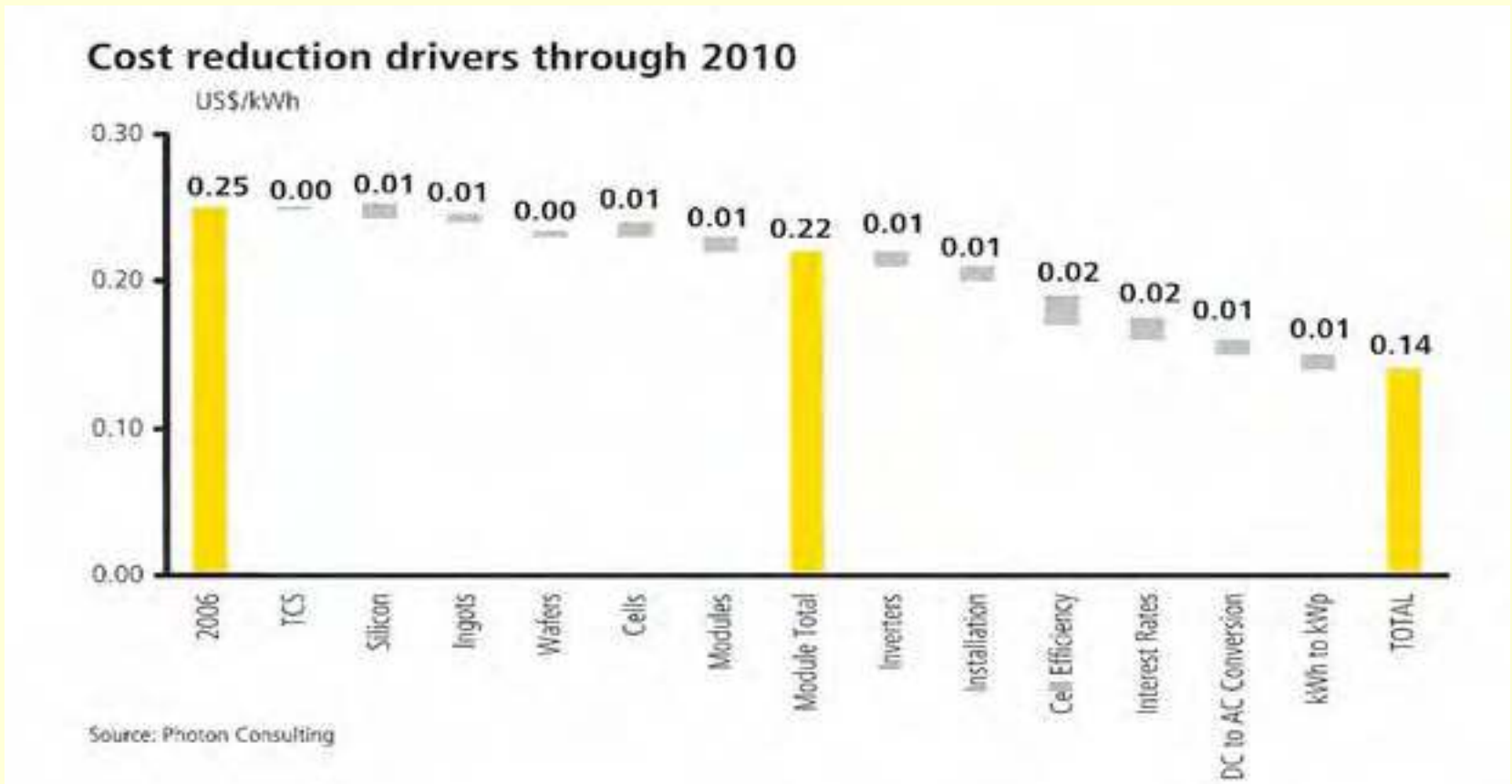



# Technical Potential Solar

Electricity: 323 km<sup>2</sup> (@ 360 TJ per km<sup>2</sup>)

Energy: 2260 km<sup>2</sup>









# PV's in Transport ?

## Distance reached with 1 ha of energy crop / PV ground-mounted system

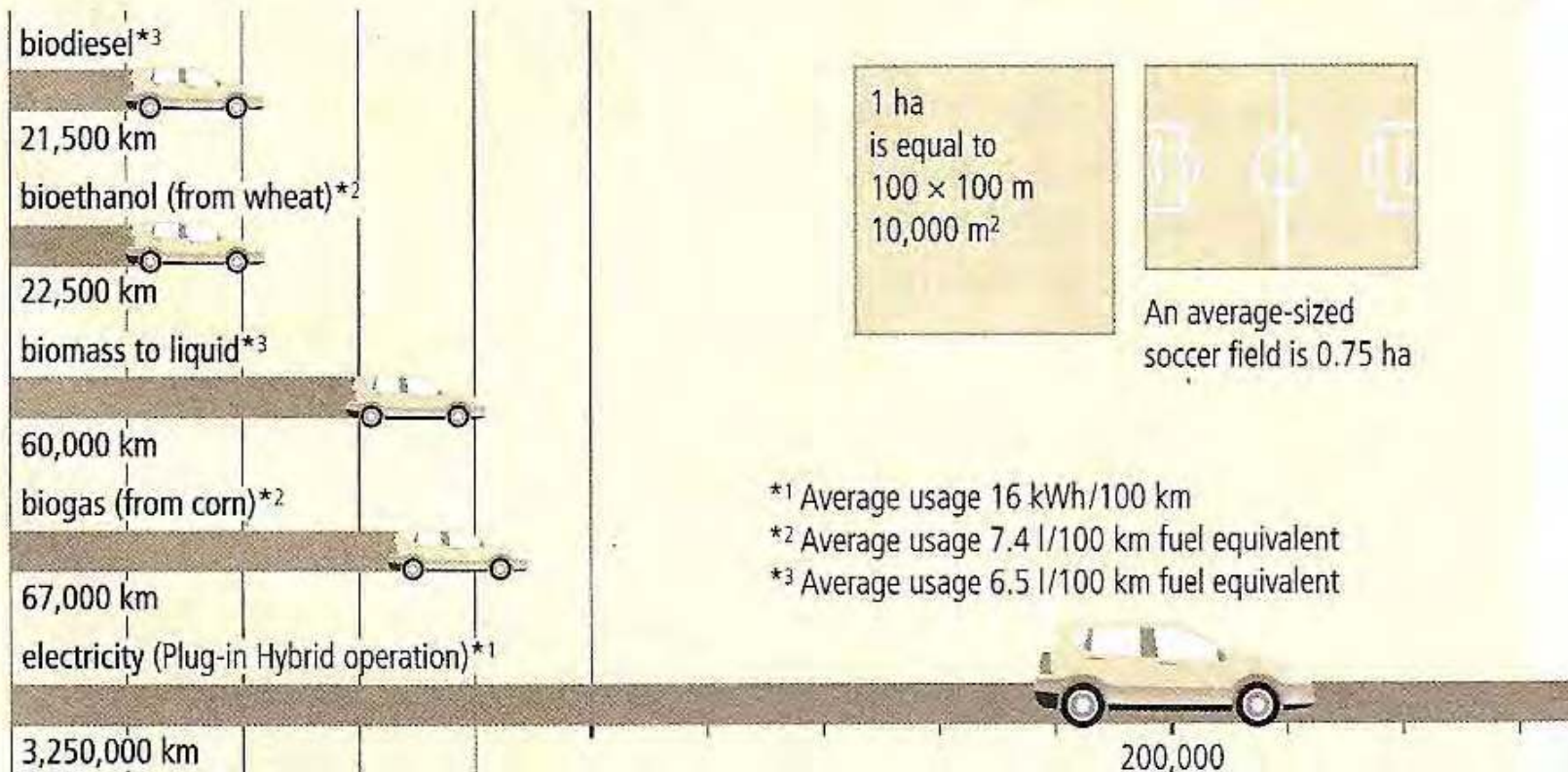

Source: Photon



# World Wide Access to Electricity

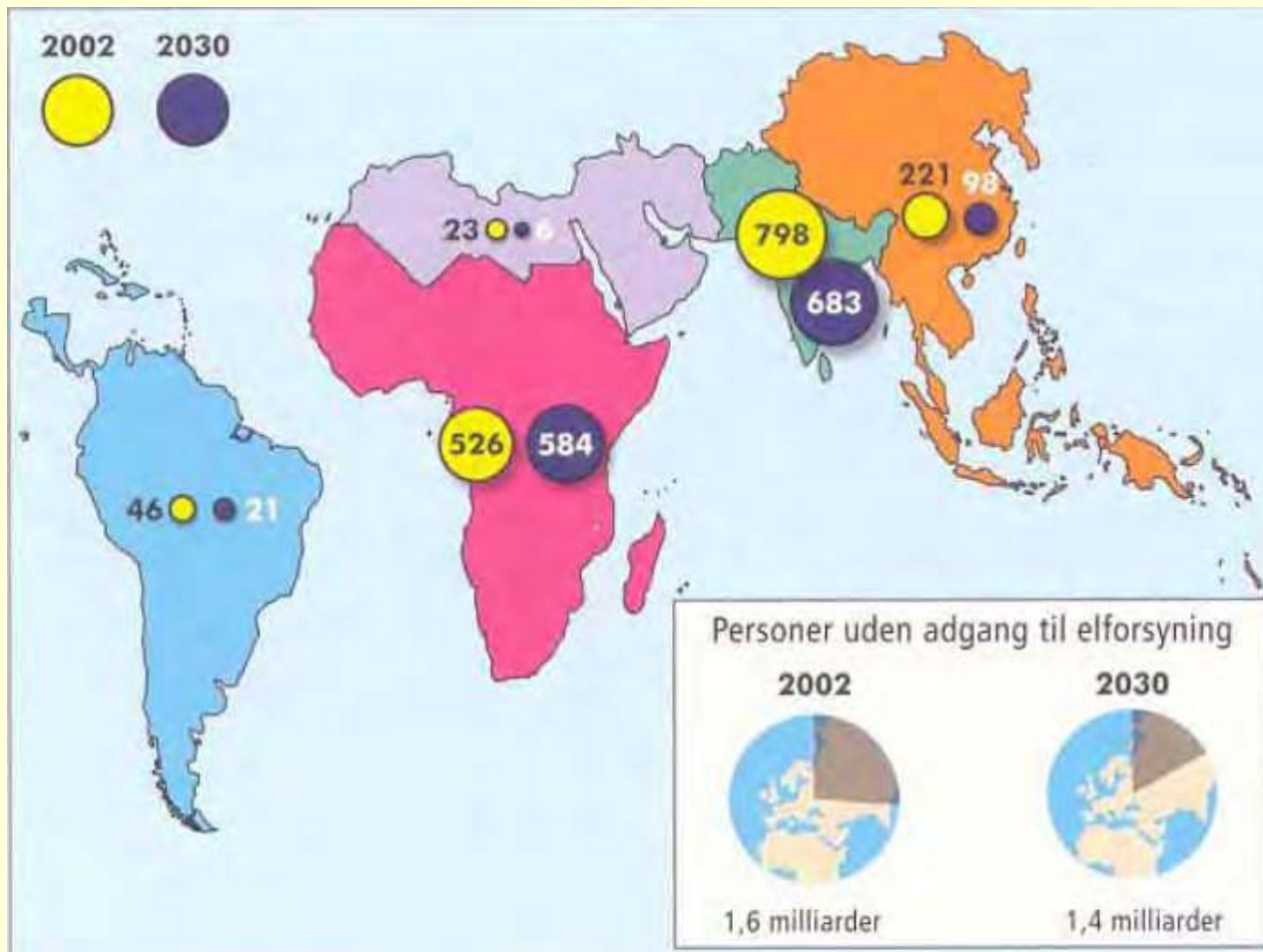

# Developing Countries – “the dark locations”



# Energy and Development – a new understanding

- Access to energy and electricity does not create development but is a prerequisite for development. Energy is not only an individual sector, but:
- Energy and electricity is a precondition for efficiency in public sectors such as: health, education, water & sanitation, good governance/ democracy
- Energy and electricity is a precondition for progress in poverty alleviation, equality, justice etc.
- Energy is a precondition in reaching the Millennium Development Goals



# WBG Photovoltaic Projects

Serving >1,43 million HH + Facilities ~7.5 million persons  
~64 MWp 31 Countries Total Value: ~\$776 million

Argentina 30,000  
Bolivia 60,000  
Ecuador 2,200  
Honduras  
Dominican Rep.  
Mexico 1,000  
Mexico 36,000  
Nicaragua 6,000

Includes projects  
completed, under  
implementation and  
preparation

Burkina Faso 8,000  
Cape Verde 4,500  
Ethiopia 6,300  
Kenya  
Madagascar 15,000  
Mali 10,000  
Morocco  
Mozambique 9,800  
Senegal 10,000  
Swaziland 2,000  
Uganda 90,000  
Tanzania 140,000

Bangladesh 198,000  
Cambodia 10,000  
China 400,000  
India 45,000+  
Indonesia 8,500  
Laos 4,000  
Mongolia 50,000  
Pacific Islands 21,000  
Philippines 135,000  
PNG 2,500  
Sri Lanka 105,000  
Vietnam













# Challenges for Solar Energy

- In the industrialized world:
  - To ensure ongoing market support until sustainable business level is reached
  - Ongoing R&D effort (not stop/go)
  - Up-scale production to GW scale, volume a major cost reduction driver
- In the developing world:
  - Develop financial structures and sustainable supply chains
  - Increase donor-support for rural electrification

# Solar Hot Water systems (SHW)





# Solar Heating Applications

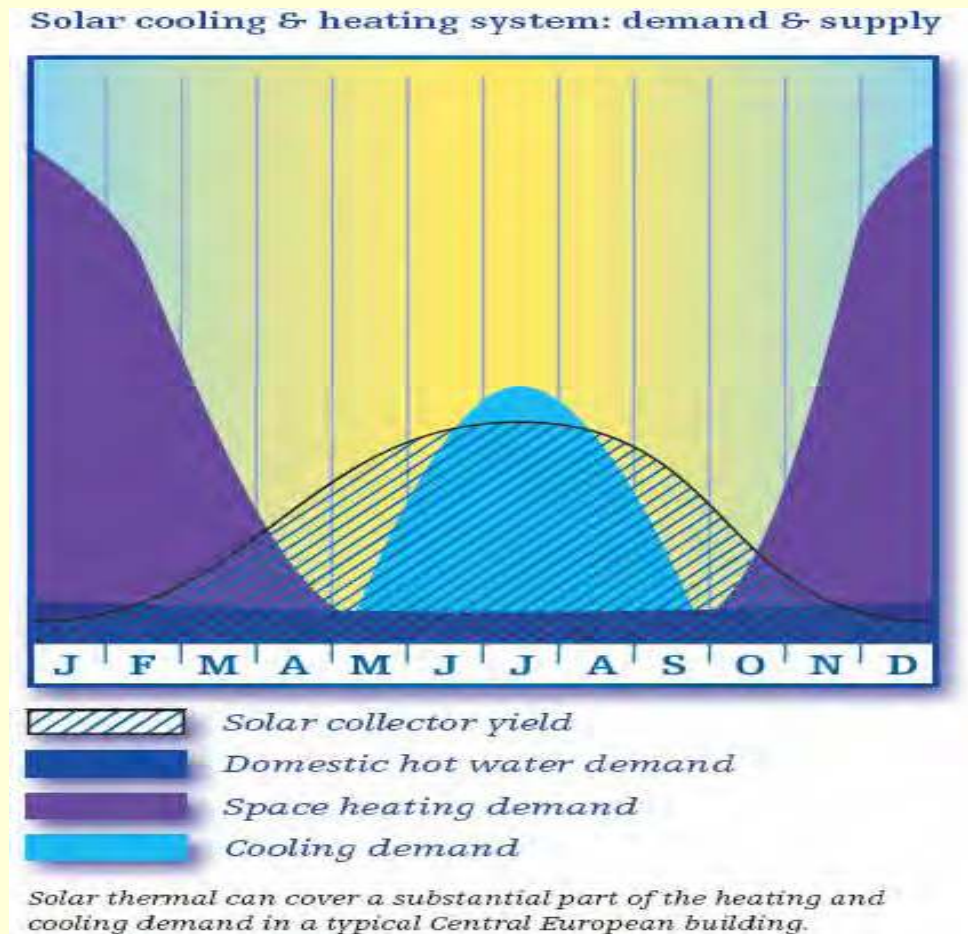



# SHW Market

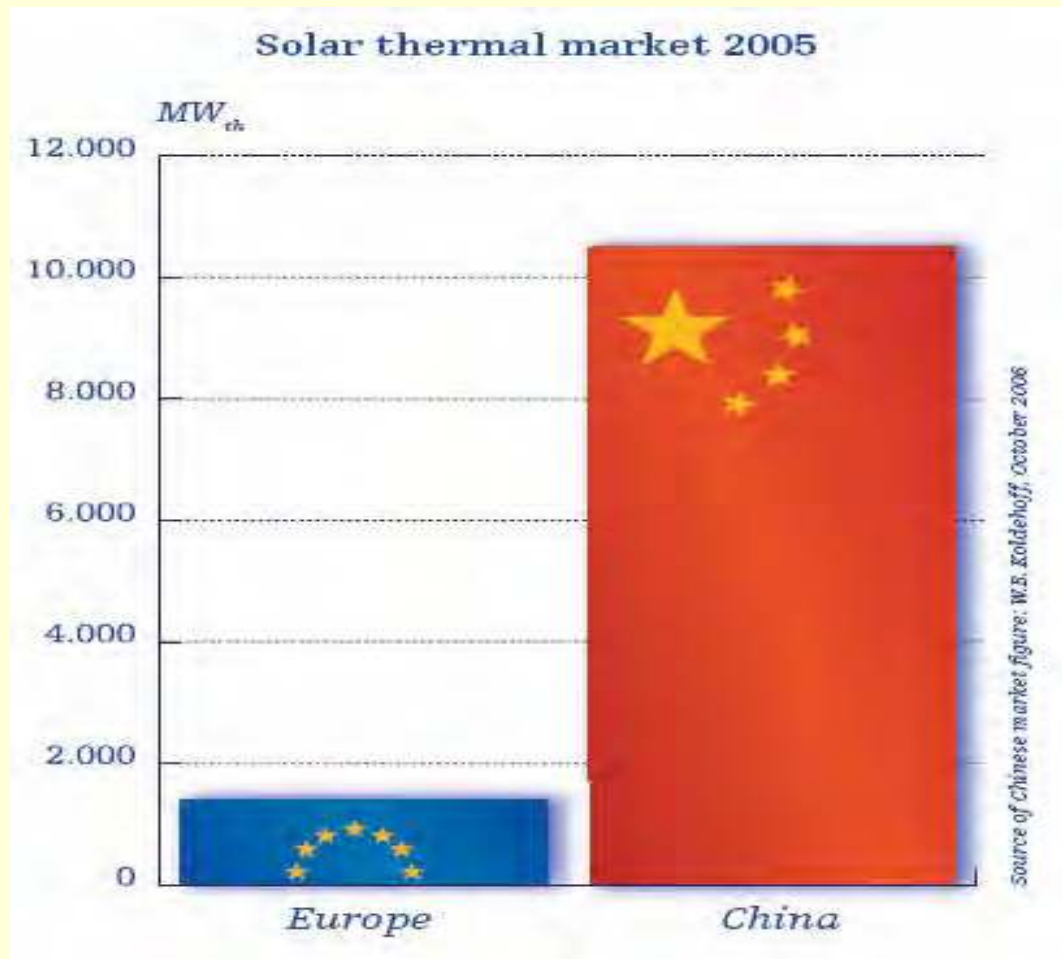

# SHW installed capacity in EU

Share of solar thermal market  
(Newly installed capacity)

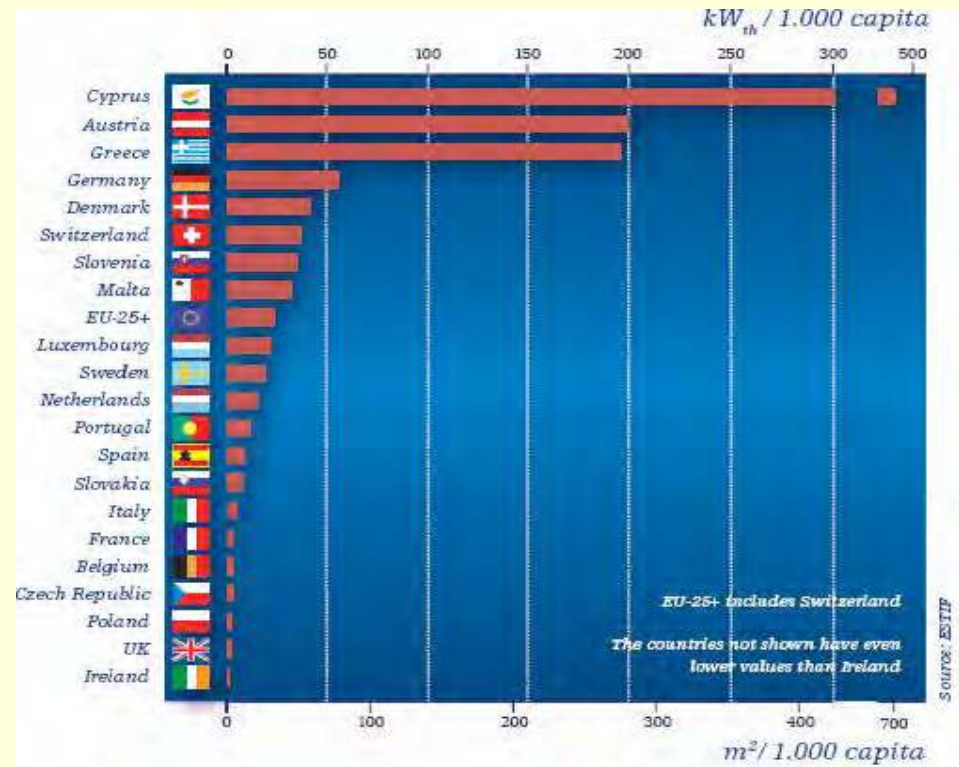

# Trends & Policies

