

Opportunistic Scheduling for Next Generation Wireless Local Area Networks

Ertuğrul Necdet Çiftçiöğlü¹ and Özgür Gürbüz²

¹The Pennsylvania State University,

²Sabancı University,

¹USA,

²Turkey

1. Introduction

Wireless access has been increasingly popular recently due to portability and low cost of wireless terminals and equipment. The emerging technologies for wireless local area networks (WLANs) are defined by the IEEE 802.11n standard, where physical layer data rates exceeding 200 Mbps are provisioned with multiple input multiple output antenna techniques. However, actual throughput to be experienced by WLAN users is considerably lower than the provided physical layer data rates, despite the link efficiency is enhanced via the frame aggregation concept of 802.11n.

In a multi user communication system, scheduling is the mechanism that determines which user should transmit/receive data in a given time interval. Opportunistic scheduling algorithms maximize system throughput by making use of the channel variations and multi user diversity. The main idea is favouring users that are experiencing the most desirable channel conditions at each scheduling instant, i.e. riding the peaks. While maximizing capacity, such greedy algorithms may cause some users to experience unacceptable delays and unfairness, unless the users are highly mobile. In order to remedy this problem, we combine aggregation and opportunistic scheduling approaches to further enhance the throughput of next generation WLANs. We argue that aggregation can dramatically change the scheduling scenario: A user with a good channel and a long queue may offer a higher throughput than a user with better channel conditions but shorter queue. Hence, the statement that always selecting the user with the best channel maximizes throughput is not valid anymore.

In this work, we first present our queue aware scheduling scheme that take into account the instantaneous channel capacities and queue sizes simultaneously, named as Aggregate Opportunistic Scheduling (AOS). Detailed simulations results indicate that our proposed algorithm offers significant gains in total system throughput, by up to 53%, as compared to opportunistic schedulers while permitting relatively fair access. We also improve AOS with the principle of relayed transmissions and show the improvements of opportunistic relaying. Later on, we propose another scheduler, which aims to maximize the network throughput over a long time scale. For this purpose, we estimate the statistical evolution of queue states and model the 802.11n MAC transmissions using queuing theory by extending the bulk service model. Utilizing the outcomes of the queuing model, we design Predictive Scheduling with time-domain Waterfilling (P-WF) algorithm. P-WF further improves the

Source: Advances in Greedy Algorithms, Book edited by: Witold Bednorz,
ISBN 978-953-7619-27-5, pp. 586, November 2008, I-Tech, Vienna, Austria

performance of our queue aware schedulers, as the throughput is maximized by applying the water filling solution to time allocations.

This chapter includes an overview of existing literature on opportunistic scheduling for wireless networks in general and presents our proposed algorithms with comparative detailed performance analysis as they are applied into the next generation WLANs.

2. Scheduling approaches for wireless networks

In a multi user communication system scheduling is an essential feature due to its effect on the overall behavior of the network. In this section, we briefly present the prominent scheduling disciplines for wireless networks. In this text, the terms *user* and *station* are used interchangeably.

2.1 Maximum Rate Scheduling (MRS) algorithm

Spatially greedy scheduling schemes, often denoted as Maximum Rate Scheduling (MRS) exploit variations in the time varying wireless channel. The selection metric is the channel capacity, allowing the user with the best channel conditions to transmit at a given time instant [Knopp & Humblet, 1995]. In other words, the selected user k_i^* at the i^{th} transmission opportunity is determined as:

$$k_i^* = \arg \max_k C_i^k, \quad (1)$$

where C_i^k denotes the channel capacity of the k^{th} user at the i^{th} transmission opportunity.

Scheduling users according to the channel state can provide significant performance gain due to the independence of fading statistics across users. This phenomenon is called multi user diversity. Although MRS method is shown to be optimal for capacity maximization, an important issue is unfairness in throughput distribution between the users, since the users subject to poor channel conditions may never get a chance to transmit.

2.2 Proportional Fair Queuing (PFQ) algorithm

In Proportional Fair Queuing (PFQ) algorithm, the user with the best channel condition (capacity) relative to its own average capacity is selected [Jalali et al., 2000]. The main aim of PFQ is to maximize throughput while satisfying fair resource allocation. If the users of all channels deviate from their mean capacities in similar ways, all users will gain access to the medium for similar proportions. Note that, being selected for similar proportions does not imply that the users have identical temporal share, since transmission to users with low data rates take longer time durations for the same amount of data. In PFQ, the selected user k_i^* can be found as:

$$k_i^* = \arg \max_k \frac{C_i^k}{\bar{C}_i^k} \quad (2)$$

where \bar{C}_i^k denotes the average channel capacity of the k^{th} user up to the i^{th} transmission opportunity.

2.3 Capacity Queue Scheduler (CQS)

When the above opportunistic schemes are employed, users with high capacity links tend to have small queues, while users subject to poor channel conditions suffer from queue

overflows and long delays. In [Neely et al., 2002], a scheduler is applied which maximizes the link rates weighted by queue backlog differentials for each link. In this downlink setting, the queue-weighted rate metric tries to select user k_i^* as

$$k_i^* = \arg \max_k C_i^k Q_i^k, \quad (3)$$

where Q_i^k denotes the queue size of the k^{th} user at the i^{th} transmission opportunity. The inclusion of queue length in this scheme provides important insights for fairness. For instance, assume initially that the queue sizes are similar for all users, except for one user whose channel is superior to others. The user with the best channel will be selected and served so its queue size will be reduced; however, in the next scheduling instant, the advantage of better channel quality will be alleviated by the smaller queue size, yielding transmission to other users. The algorithm guarantees stability whenever the arrival rate vector lies within the stability region of the network.

2.4 Shortest Remaining Processing Time First (SRPT) algorithm

Another scheduling algorithm that considers queue size together with capacity is Shortest Remaining Processing Time First (SRPT) method, where the metric is defined as the amount of time it takes to serve all the packets from a given queue [Schrage & Miller, 1966]. Here, the scheduler tries to choose the queue, which can be emptied in the shortest amount of time, i.e., the selected user k_i^* at the i^{th} transmission opportunity is determined as:

$$k_i^* = \arg \min_k \frac{Q_i^k}{C_i^k}. \quad (4)$$

2.6 Opportunistic Autorate (OAR) algorithm

Opportunistic Autorate protocol (OAR) is an opportunistic scheduler which takes into account the effect of aggregation, as the users are served in a round-robin fashion [Sadeghi et al., 2002]. While serving each user, the number of packets transmitted for the user depends on the ratio of the user rate to basic rate, hence operating with larger aggregate sizes for users with better channel conditions. It is worthwhile to note that OAR provides temporal fairness since the packet transmission times for each user are equal.

2.7 Longest Queue (LQ) algorithm

Longest Queue (LQ) algorithm, which is also one of the considered schemes for 802.11n [Mujtaba, 2004], is a non-opportunistic scheduling scheme. Using LQ, the scheduler simply selects the station with the largest number of packets in its queue and the channel states are not taken into account. In LQ, the selected user k_i^* is found as

$$k_i^* = \arg \max_k Q_i^k \quad (5)$$

The queues of users which have not been served for a long time duration are likely to be long, increasing the scheduling metrics and eventually causing the associated user to be served. The reasoning behind the LQ algorithm is to maximize the aggregate size for maximizing the throughput, with the basic assumption that users are experiencing similar

channels with equal data rates. However, the channel quality of stations can vary notably due to time-varying wireless channel and mobility [Rappaport, 2002].

In all of these approaches, the scheduler operates at the physical layer, considering the channel quality and/or queue level for the decision of the selected user. Once the user is selected, the implicit assumption is that a single physical layer data unit is transmitted and the link is fully utilized. With the frame aggregation feature of 802.11n, a number of packets are combined before transmission, so that WLAN overhead is reduced and link efficiency is improved [Tinnirello & Choi, 2005], [Liu & Stephens, 2005]. However, with aggregation, the advantages of opportunism and the statement that selecting the user with the highest channel capacity maximizes the throughput is not valid anymore. For instance, the MRS algorithm with frame aggregation may starve since specific stations are to be served more frequently, their queues will be drained, causing their aggregate sizes to be small, resulting in low efficiency and throughput. Algorithms such as SRPT favour users with high capacity and small queue sizes, which is even worse with frame aggregation causing low throughput. OAR considers frame aggregation and provides temporal fairness, but does not aim throughput maximization. When aggregation is employed, a user with a fair channel and long queue may result in a much higher throughput than a user with a high capacity channel but small queue size. In this work, we study all of the aforementioned algorithms with frame aggregation in the setting of next generation IEEE 802.11n WLANs. We also propose new scheduling algorithms that aim to enhance the performance and fill the performance gap between available and observed data rates by jointly considering channel and queue states of users via throughput calculations.

3. System model

We consider the downlink of a Multiple Input Multiple Output (MIMO) [Telatar, 1999] wireless cellular system that consists of a single access point (AP) communicating with multiple WLAN clients (Figure 1). The system is a closed-loop MIMO OFDM system such that the mobile users measure their channel states and send them as feedback to the AP. Based on the channel state, link capacities are calculated and 802.11n data rates are assigned at the AP according to available capacity¹. The properties of the fading wireless channel are modeled in the channel matrix H , considering large-scale path loss, shadowing and small scale multi-path fading affects. In this paper, the log distance path loss model and the Channel B fading channel model defined by the Task Group n (TGn) are considered. The fading characteristics between individual antenna pairs are spatially correlated and the correlation matrices depend on the angular spread. Further details of the channel model can be found in [Erceg et al., 2004]. Due to low speeds of WLAN users, coherence time is large enough so that channel fading is slow, i.e. the channel is assumed stationary within one transmission opportunity.

¹ In MIMO-OFDM based systems, the channel capacity is calculated by partitioning the system into multiple sub-channels that correspond to different sub-carriers as follows

$$[\text{Bolcskei et al., 2002}]: C = \frac{B}{N_c} \sum_{k=0}^{N_c-1} \log_2(\det(\mathbf{I}_{M_{N_c}} + \rho \mathbf{H}(e^{j2\pi \frac{k}{N_c}}) \mathbf{H}^H (e^{j2\pi \frac{k}{N_c}}))), \quad \text{with } \mathbf{H}(e^{j2\pi \theta}) = \sum_{l=0}^{L-1} \mathbf{H}_l e^{-j2\pi l \theta}$$

(N_c : Number of subcarriers). The capacity calculation here considers the air interface specified in 802.11n draft standard. However, the scheduling algorithms can be applied to any other air interface with appropriate capacity calculations.

For medium access, we consider a time division system where only one user is served at a given time period, limited by a duration called transmission opportunity (TXOP).

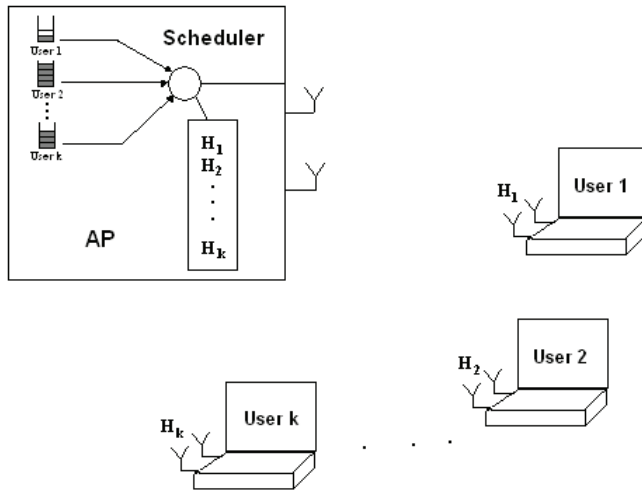

Fig. 1. A typical 802.11n AP and terminals

As defined by 802.11n draft standard, within a TXOP, a two-way handshake with frame aggregation can be performed as shown in Figure 2 [Mujtaba, 2004]. Initiator Aggregation Control (IAC) and Responder Aggregation Control (RAC) are RTS/CTS-like reservation messages, which also involve training sequences to help (MIMO) channel estimation and data rate selection.

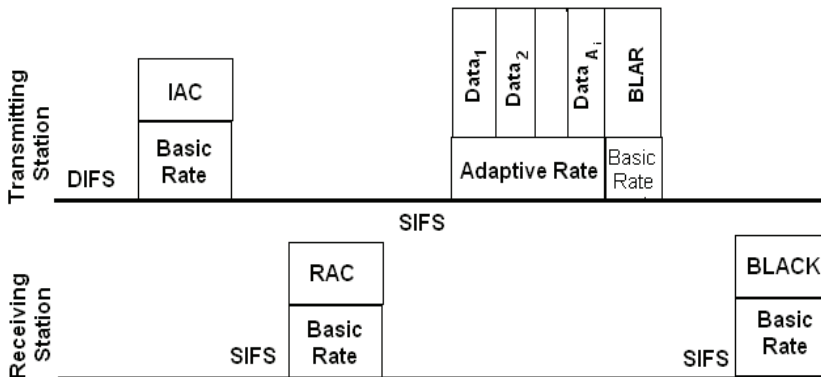

Fig. 2. Example aggregate frame transmission

After IAC/RAC exchange, a number of data packets are aggregated in one frame and an acknowledgement is requested in the end via the Block ACK Request (BLAR) packet. The destination station replies with a Block ACK (BLACK) packet that contains the reception status of packets in the aggregation. The data packets are transmitted at the selected transmission rate, while the control packets (IAC, RAC, BLAR and BLACK) are transmitted at the basic rate, so that all stations can decode these packets. The inter frame spacing (DIFS,

SIFS) values are as in the 802.11 specification. At each TXOP, the AP transmits to a station selected according to the implemented scheduling algorithm.

4. Proposed scheduling algorithms for next generation WLANs

4.1 Aggregate opportunistic scheduling

Despite the performance enhancing techniques introduced by IEEE 802.11n, namely MIMO and frame aggregation, the throughput observed by the system depends on the channel and queue states of the selected user, hence scheduling. Our motivation here is that throughput can essentially shape scheduling, and we propose *Aggregate Opportunistic Scheduling (AOS)* algorithm [Ciftcioglu & Gurbuz, 2006], where the scheduler tries to maximize the instantaneous throughput when the AP is transmitting a number of packets in aggregation to a selected user. In other words, for i^{th} TXOP, the AOS scheduler selects a user k_i^* as

$$k_i^* = \arg \max_k S_i^k, \quad (6)$$

where S_i^k is the throughput calculated for i^{th} TXOP and k^{th} user with the actual system overhead and parameters, as shown next. Considering traffic destined to the k^{th} station in the i^{th} TXOP, the point-to-point downlink throughput, S_i^k , can be calculated as

$$S_i^k = \frac{A_i^k \cdot L_p}{\frac{L_{IAC}}{r_0} + \frac{L_{RAC}}{r_0} + 4 \cdot T_{PLCP} + DIFS + 4 \cdot \tau + 3 \cdot SIFS + \frac{L_{BLACK}}{r_0} + \frac{L_{BLAR}}{r_0} + \frac{A_i^k \cdot (L_p + L_{MH})}{C_i^k}} \quad (7)$$

with A_i^k being the instantaneous aggregate size to user k at i^{th} TXOP and L_p , L_{IAC} , L_{RAC} , L_{BLACK} , L_{BLAR} are the length of the data, reservation, ACK and ACK request packets, respectively. L_{MH} is the MAC header in bits, T_{PLCP} is duration of physical layer training header, τ is the one way propagation delay and DIFS, SIFS are inter frame spacing times specified in 802.11 [Mujtaba, 2004]. Finally, r_0 is the basic data rate at which control packets are transmitted and C_i^k is the instantaneous capacity, i.e., maximum achievable data rate to communicate with user k , which depends on the channel state. Instantaneous aggregate size is determined as the minimum of the user's queue size and the maximum allowable aggregation size, which is set according to limit of transmission opportunity duration. Here, only the downlink traffic is considered, hence there are no collisions and losses are merely due to protocol, packet and physical layer overhead.

Another version of AOS, *Aggregate Discrete Opportunistic Scheduling (ADOS)* is also developed with slight modifications. In ADOS, again the throughput maximizing user is selected, but the throughput values are calculated by substituting one of the specified transmission rates of 802.11n, r_i^k for capacity, C_i^k in throughput calculation in (7). r_i^k is selected from the set, $R_d = \{12, 24, 36, 48, 72, 96, 108, 144, 192, 216\}$ Mbps through a rate matching mechanism, as defined in [Mujtaba, 2004].

4.2 Scheduling with relaying

In this section, we try to take advantage of relaying in our schedulers through increased data rates due to reduced path loss. Relaying offers improvements in throughput and range

extension in wireless networks, making use of multihop communication [Boyer et al.,2004], [Sreng et al., 2002]. Using intermediate relaying stations enables the communication to be carried out through shorter distances where the path loss much is lower as compared to direct transmission. The reduced path loss results in range extension or improved reliability over the same range, which enables transmitters to use lower transmission powers or using higher data rates.

Our aim is to exploit relaying when it offers throughput enhancement with the information available at the AP. For simplicity, we consider only one relaying station. Figure 3 below shows the relaying scenario, where the end station is located at d_f meters from the AP operating at data rate r_f , and the relay station is located at d_1 (operating at data rate, r_1). The distance between the relay and end stations is d_2 , and the data rate of the corresponding link is r_2 . Figure 4 depicts our modifications to 802.11n transmission sequence so as to allow frame aggregation in relaying mode.

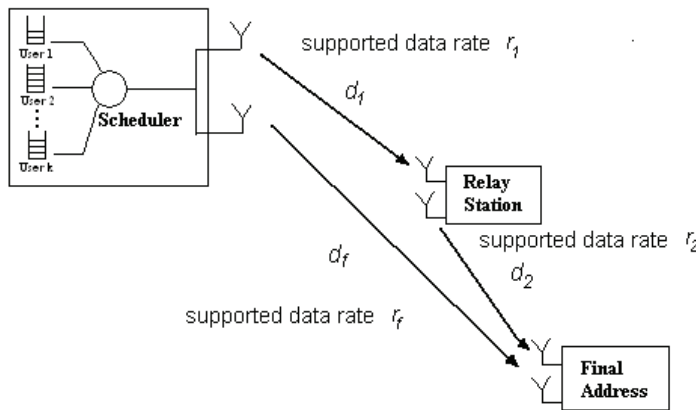

Fig. 3. Relaying with one relay station.

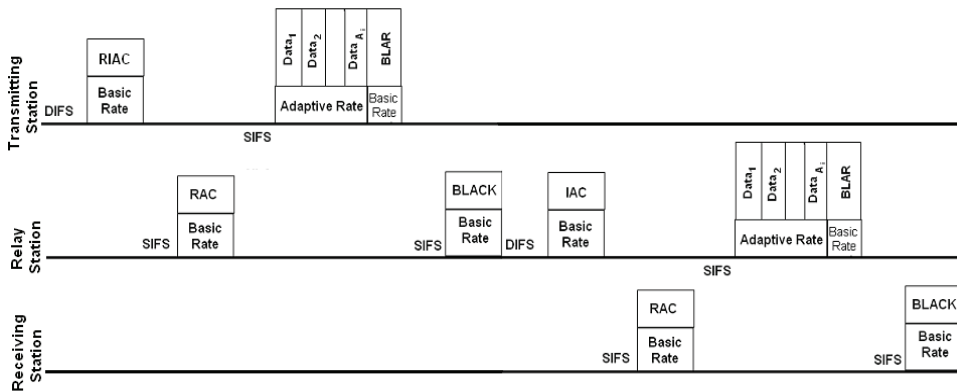

Fig. 4. Frame aggregation with one relay station in IEEE 802.11n.

In order to implement relaying over the 802.11n protocol, the first IAC packet is modified as Relayed IAC (RIAC) by adding fields to the packet which indicate whether relaying is

required or not and the address of the relaying station. The relay station initiates another contention-free transmission sequence to the destination. A new transmission sequence will not be initiated at the AP unless the Block ACK is received from the end station. The principle of relaying structure can also be applied to wireless mesh networks [Bicket et al., 2005], [Navda et al., 2005] using the IEEE 802.11n interface.

In order to determine whether relaying is beneficial for transmitting data to an end user or not, we compare the transmission durations. Without relaying, the total transmission duration to the end station is given by:

$$T_{direct} = \frac{L_{IAC}}{r_0} + \frac{L_{RAC}}{r_0} + 4.T_{PLCP} + DIFS + 4.\tau + 3.SIFS + \frac{L_{BLACK}}{r_0} + \frac{L_{BLAR}}{r_0} + \frac{A.L_P}{r_f} \quad (8)$$

$$= T_{overhead} + \frac{A.L_P}{r_f} \quad (9)$$

When relaying is employed, the resulting transmission duration is found as:

$$T_{relay} = 2.T_{overhead} + \frac{A.L_P}{r_1} + \frac{A.L_P}{r_2} \quad (10)$$

Clearly, relaying is beneficial if relaying offers a shorter transmission duration than direct transmission, i.e., when $T_{relay} < T_{direct}$. An alternative approach to determine whether relaying is beneficial is to define an *equivalent relaying rate*. For this, we decompose equation (10) as follows:

$$T_{relay} = T_{overhead} + \frac{A.L_P}{r_1} + \frac{A.L_P}{r_2} + T_{overhead} \quad (11)$$

$$T_{relay} = \left(\frac{1}{r_1} + \frac{1}{r_2} + \frac{T_{overhead}}{A.L_P} \right) A.L_P + T_{overhead} \quad (12)$$

Note that the form of (12) is similar to (9) with the total duration as the sum of overhead delay and a rate-dependent term multiplied by the aggregated frame size, in bits. We define the equivalent relaying rate as

$$r_{equivalent} = \left(\frac{1}{r_1} + \frac{1}{r_2} + \frac{T_{overhead}}{A.L_P} \right)^{-1}, \quad (13)$$

and rewrite (12) as

$$T_{relay} = T_{overhead} + \frac{A.L_P}{r_{equivalent}} \quad (14)$$

$r_{equivalent}$ not only consists of rate-dependent terms, but it also depends on the aggregate size, A which in turn depends on the queue state for the final station. Hence, increasing aggregate size increases the equivalent relaying rate.

Considering relaying, the queue aware schedulers have been modified as follows: For each destination station, the effective *relaying rate*, $r_{equivalent}$ is calculated using (13) considering each possible intermediate station as a relay station. Then, the best relaying station is selected as the station which enables the maximum effective relaying rate to the destination station. Next, the selected maximum effective relaying rate is compared to the direct rate. If relaying rate is larger than direct transmission rate, relaying is to be preferred, hence the corresponding metric, η_k of the scheduler (AOS, CQS, LQ etc.) is computed for user k using effective relaying rate. If the relaying rate is smaller than direct rate, the metric η_k is computed according to direct transmission. In the end, user scheduling is performed by selecting the user that maximizes the selection metric according to, $k^* = \arg \max_k \eta_k$.

Typically, relaying will improve the rates of stations with poor channel conditions which are located far away from the AP, equivalently increasing their metrics, increasing their chances for being served by the AP. As a result, we expect relaying to improve the fairness performance of the schedulers. In addition, since higher effective data rates are used, relaying should improve throughput of the non-opportunistic scheduler LQ. For opportunistic schedulers, both effective data rates and the proportion of service for users with poor channels are expected to increase.

4.3 Predictive scheduling with time waterfilling

Selecting the user that maximizes the instantaneous throughput at a specific transmission opportunity may lower the throughput in the subsequent transmission opportunities. Likewise, increasing the participation of low capacity users can later enable the higher capacity users to transmit with larger aggregate sizes and hence result in higher efficiency and throughput. Our aim in this section is to design *block* scheduling algorithms that perform allocation of multiple users, so as to maximize the overall throughput over a long term, the duration of which is set as an external parameter. Hence, we propose an algorithm where the access privileges and proportions of users are determined based on *predicted* per user aggregate size and throughput values. A queuing model is first developed for analyzing packet queueing after transmissions with frame aggregation in 802.11n downlink channel and then the outcomes of the queuing model are used to calculate long term average aggregate size and average throughput, which are then utilized in designing the heuristics of *Predictive Scheduling with Time Water-filling (P-WF)*.

4.3.1 Queuing formulation

Here, we devise a queuing model for aggregate frame transmissions of the 802.11n MAC by extending the bulk service model in [Kleinrock, 1975]. From this queuing model, we compute the state probabilities, where each state corresponds to the number of packets included in the bulk that is an aggregate frame. By using the obtained state probabilities, we compute the expected aggregate size and throughput per user, and then the long term overall system throughput and accordingly design the metrics of the block schedulers. Figure 5 shows the bulk service model, where the packets are served collectively in groups and incoming packets are enqueued. Packets arrive one by one with an average rate, λ packets/second. All of the packets in the queue are served together if the number of packets is less than the bulk size, L . If the queue length exceeds L , only the first L packets are served.

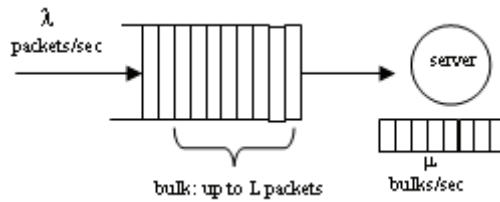

Fig. 5. Bulk service system

The bulk service rate, μ , is defined as the rate of serving bulks, which is assumed constant for all states [Kleinrock, 1975].

The assumption of constant bulk service rate implies that the processing rate in bits per second is to be increased proportionally with the bulk size. For transmissions over a wireless link, the channel data rate can vary due to variations in channel conditions, but in a given rate setting data transmission rate does not change with bulk size. Moreover, in realistic aggregate frame transmissions MAC and physical layer overhead should also be taken into account in determining the service rates. Therefore, for our queuing model of aggregate transmission, the service rate μ_j is variable and is obtained as:

$$\mu_j = \begin{cases} \frac{\mu}{j} \cdot \left(\frac{j \cdot L_p}{j \cdot (L_p + L_{MH}) + L_{overhead} + r \cdot T_{IFS}} \right) & 1 \leq j < L, \\ \frac{\mu}{L} \cdot \left(\frac{L \cdot L_p}{L \cdot (L_p + L_{MH}) + L_{overhead} + r \cdot T_{IFS}} \right) & j \geq L, \end{cases} \quad \text{bulks/sec} \quad (15)$$

where j is the number of packets involved in the aggregation; μ is the rate of serving bulks; $L_{overhead}$ accounts for the total overhead including PHY and MAC headers; T_{IFS} is the sum of interframe durations; r is the channel data rate determined according to the channel conditions which vary over time due to fading.

Assuming Poisson packet arrivals, i.e., exponential inter arrival times, helps us to model the queuing system in terms of a Markov chain, due to the memoryless property of exponential distribution [Kleinrock, 1975]. Although Poisson distribution may exactly model the data traffic applications, it provides an adequate reference for comparing the evolution of different user queues in the AP, hence a relative performance can be obtained for scheduling purposes. Similar assumptions have been made in previous work on modeling WLAN traffic [Bianchi, 2000] as well as scheduler design [Zafer & Modiano, 2005]. Figure 6 depicts the Markov chain representation of the queueing model of aggregate frame transmissions, defining the state as the number of packets in the queue. Packets arrive at average rate λ , and bulks are served at rate μ_j , given by Eq.(15).

Using this model, we derive the state probabilities, p_1, p_2, \dots, p_L , at steady state by solving the balance equations:

$$\lambda p_0 = \mu_1 p_1 + \mu_2 p_2 + \dots + \mu_L p_L \Rightarrow p_0 = (1/\lambda) \sum_{j=1}^L \mu_j p_j \quad (16a)$$

$$(\lambda + \mu_j)p_j = \mu_L p_{j+L} + \lambda p_{j-1} \quad 1 \leq j \leq L \tag{16b}$$

$$(\lambda + \mu_L)p_j = \mu_L p_{j+L} + \lambda p_{j-1} \quad j \geq L \tag{16c}$$

Converting the balance equations into the alternative form by taking the z-transform, we obtain $P(z)$ in rational form as follows:

$$P(z) = \frac{\sum_{j=1}^L [z^{L+j}(\mu_j - \mu_L) - z^L(\mu_j + \frac{\mu_L \mu_j}{\lambda}) + \mu_L z^j + \frac{\mu_L \mu_j}{\lambda}] p_j}{\lambda z^{L+1} - (\lambda + \mu_L) z^L + \mu_L} \text{ i.e.,} \tag{17}$$

$$P(z) = \frac{N(z)}{D(z)} \tag{18}$$

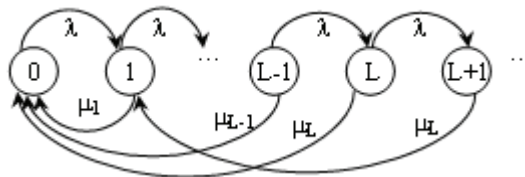

Fig. 6. Markov-chain representation of aggregate frame transmission

The global sum of probabilities should be equal to 1, requiring $P(1)=1$ to be satisfied. Since both $N(1)=0$ and $D(1)=0$, we need to utilize the L'Hospital rule and solve $\lim_{z \rightarrow 1} \frac{N'(z)}{D'(z)} = 1$. The

next step is to obtain state probabilities by taking the inverse transform of $P(z)$. The fact that the bulk service rates are state-dependent has caused the order of $N(z)$ to be greater than the order of $D(z)$, so $P(z)$ cannot be simplified. We take an alternative approach as follows: Similar to the bulk service model solution in [Kleinrock, 1975], out of the $(L+1)$ roots of $D(z)$, $(L-1)$ roots are located within the unit circle. Due to the fact that the z-transform of a probability distribution is analytical inside the unit circle, $P(z)$ should be bounded, which implies that $(L-1)$ zeros of $P(z)$ must also be the roots of the numerator $N(z)$. $N(z)$ must also vanish at each of the $(L-1)$ roots of $D(z)$ inside the unit circle. This constraint results in a set of $(L-1)$ equations. Including the equation provided by the L'Hospital rule, we obtain L equations for probabilities p_1, p_2, \dots, p_L and Eq. (16) provides the solution for p_0 . The set of equations is solved via numerical computations, obtaining the steady-state probabilities of the system for all the states up to the aggregation limit L . The expected aggregate size, \bar{A} , and expected throughput, \bar{S} , are found as the ensemble average, via

$$\bar{A} = \sum_{j=1}^L j \cdot p_j + L \cdot (1 - \sum_{j=0}^L p_j) \tag{19}$$

$$\bar{S} = \sum_{j=0}^L p_j S(A_j) + (1 - \sum_{j=0}^L p_j) S(L) \tag{20}$$

where $S(A_j)$ is the throughput achieved with aggregate size A_j .

The queuing model provides us the *expected aggregate size* and *expected throughput* for a single queue (user) given the service rate and applied load. Considering the multi user scenario with time-division multiplexed traffic, the parameters for the queuing model need to be modified by taking the temporal access proportions into account. Given the temporal access proportion of a user as π_n , where $\pi_n \in [0,1]$, the effective channel service rate of that user is to be computed by scaling its link rate by π_n . From Eq. (17), it can be verified that, scaling the service rate by π_n with a given load level has the same effect as keeping service rate and scaling the load level by a factor of $1/\pi_n$. Hence, the effective load at the n th user queue is obtained as λ_n/π_n , and the bulk service rate μ_j is found from Eq. (15) as a function of the data rate of the served user's wireless channel (r_n) and the aggregate size j_n . After computing the state probabilities, the expected throughput per user n , \bar{S}_n , is obtained as:

$$\bar{S}_n = f(\pi_n) = \begin{cases} \frac{\lambda_n}{\pi_n}, & \frac{\lambda_n}{\pi_n} < S(L) \\ S(L), & \frac{\lambda_n}{\pi_n} > S(L) \end{cases}, \quad (21)$$

where $S(L)$ is the maximum throughput that can be achieved with the maximum allowed aggregate size, L . The overall network throughput is obtained as the weighted average of the per user throughput values:

$$S_{total} = \sum_{n=1}^N \pi_n \bar{S}_n, \quad (22)$$

with N being the total number of users to be scheduled.

The calculation of the state probabilities and estimation of queue size and throughput are to be implemented the AP. The AP has the per user information of traffic load, channel (service) rates and queue states available. Channel states are assumed to be stationary within a scheduling duration, as fading is assumed to be slow due to low mobility in indoor WLANs.

4.3.2 Algorithm description

In order to maximize the total throughput, S_{total} obtained in (22) we propose *Predictive Scheduling with Time-domain Water-filling (P-WF)* [Ciftcioglu & Gurbuz, 2007] as a block scheduling solution that optimizes temporal access proportions, π_n for a given number of users, N . The scheduling problem is described as:

$$\arg \max_{\pi_n} \sum_{n=1}^N \pi_n \bar{S}_n \quad \text{such that} \quad \sum_{n=1}^N \pi_n = 1. \quad (23)$$

The above problem resembles the power allocation problem among users or multiple transmit antennas for maximizing capacity of multi user or multi antenna fading channels, solved by water-filling. In a water filling problem in general, the aim is to maximize the weighted average of a quantity in the form:

$$\max \sum_{n=1}^N (\beta + \gamma_n x_n) \text{ with the constraint } \sum_{n=1}^N x_n = 1. \tag{24}$$

The solution for (x_1, x_2, \dots, x_N) is given as [Cover & Thomas, 1991]:

$$x_n^{opt} = \left(\zeta - \frac{\beta}{\gamma_n} \right)_+, \quad n = 1, \dots, N, \tag{25}$$

where $(\theta)_+$ denotes $\max(\theta, 0)$. For the power allocation problem, the solution, x_n^{opt} is the optimal transmission power level for each channel n with SNR value γ_n and the power cut-off value, ζ is a function of receiver’s acceptable threshold SNR. We exploit the mathematical analogy between equations (23) and (24), where power level is analogous to temporal access proportion. Then, we apply the concept of waterfilling for determining the time proportions π_n that maximize S_{total} and we name this method as *time-domain waterfilling*. In order to achieve a full analogy between the equation pairs, we add a constant into the summation term on the left in Eq. (23) and obtain:

$$S' = \sum_{n=1}^N (\beta + \pi_n \bar{S}_n). \tag{26}$$

Maximizing S' is equivalent to maximizing S_{total} , so the waterfilling solution is found as:

$$\pi_n = \left(\zeta - \frac{\beta}{\bar{S}_n} \right)_+, \quad n=1, \dots, N \tag{27}$$

Unlike traditional waterfilling, the solution cannot be computed directly due to the coupling between the waterfilling terms, \bar{S}_n and π_n . At this point, we propose the following heuristic algorithm to find best π_n values:

1. Initialize all temporal proportions equally, as $\pi_n^0 = 1/N$ for $n=1 \dots N$.
2. For iteration i ,
 - Compute the effective load values, $\lambda_n^i = \frac{\lambda_n^0}{\pi_n^i}$, for each user, $\forall n$.
 - Calculate the per user average aggregate size, $A^i(\lambda_n^i)$ and per user throughput, $S^i(\lambda_n^i)$ from the analytical model.
 - Find access proportions from water filling solution as $\pi_n^{i+1} = \left(\zeta - \frac{\beta}{S^i(\lambda_n^i)} \right)_+$ also

solving for cut off value, ζ using $\sum_{i=0}^N \left(\zeta - \frac{\beta}{S^i(\lambda_n^i)} \right)_+ = 1$. Initially, all of the access

proportions are assumed to be greater than zero, and cut off is obtained as: $\zeta = \frac{1}{N} + \frac{1}{N} \sum_{i=0}^N \left(\frac{\beta}{S^i(\lambda_n^i)} \right)$. If $\frac{\beta}{S^i(\lambda_n^i)} > \zeta$ is satisfied for all users, the iteration is completed. Otherwise, cutoff is calculated by eliminating users with low throughput, until the number of users surpassing ζ is consistent with the number of terms in the summation.

Step 2 with its sub steps is repeated until, after a finite number of iterations, the access proportions (π_n, s) converge. The resulting proportions indicate optimal transmission durations of the users relative to the total transmission sequence in which scheduling is applied. Users below the threshold ratio are not served, similar to waterfilling schemes for power allocation, where poor channels are not allowed to transmit when their Signal to Noise Ratio (SNR) fall below the cutoff value.

Having determined the temporal access proportions, next, we need to determine the sequence of transmissions for the selected active users. For this purpose we use an approach that is similar to calculation of finish tags in fluid fair queuing [Leon Garcia & Widjaja, 2004]. Each active user is assigned a turn number, which indicates the number of times the user will be given access throughout the total scheduling duration. The turn number, t_n for user n is determined in two steps: First, the ratio of the access proportion of the user to the transmission duration of serving that user is calculated, then all calculated turn numbers are scaled with respect to the minimum turn number. In other words,

$$t_n = \frac{\pi_n^*}{T_n} = \frac{\pi_n^*}{((\overline{A}_n \cdot L_p)/r_n + T_{overhead})} \quad (28)$$

$$t' = \min_{\pi_n > 0} \left(\frac{\pi_1^*}{T_1}, \frac{\pi_2^*}{T_2}, \dots, \frac{\pi_{N_{Active}}^*}{T_{N_{Active}}} \right), t_1 = \frac{t_1}{t'}, t_2 = \frac{t_2}{t'}, \dots, t_{N_{Active}} = \frac{t_{N_{Active}}}{t'} \quad (29)$$

where T_n is the transmission duration of serving user n , \overline{A}_n is the average aggregate size calculated from the queuing model for user n , $T_{overhead}$ refers to the sum of all the overhead terms in Eq. (7). The optimal solution can yield some of the users with a zero access proportion, so N_{Active} is the total number of users with a non-zero access proportion. The transmissions of those active users are scheduled in ascending order of their turn numbers. This ordering makes sure that the users with the smaller access proportions get their allocation before the others.

5. Performance evaluation

5.1 Performance of scheduling algorithms

In this section, the performance of proposed *Aggregate Opportunistic Scheduling* (AOS and ADOS) and *Predictive Block Scheduling with Time-Waterfilling* (P-WF) schemes are evaluated in comparison to the scheduling disciplines from the literature namely LQ [Mujtaba, 2004], MRS [Knopp & Humblet, 1995], PFQ [Jalali et al., 2000], CQS [Neely et al., 2002], SRPT [Schrage & Miller, 1966] and OAR² [Sadeghi et al., 2002]. The simulations are carried out in the OPNET simulation environment, modeling the wireless channel, physical layer parameters, 802.11 MAC layer with 802.11n enhancements and the scheduling algorithms. For the wireless channel, the log-normal path loss model is simulated with path loss exponent of 2 and log-normal shadowing deviation of 3 dB within a distance of 5 meters

² The OAR algorithm defines the aggregate size as the ratio of the data rate of the station over basic rate. Here, we have considered two versions of OAR, where the algorithm is applied with a basic rate of 12 Mbps (OAR-12) and with a basic rate of 24 Mbps (OAR-24).

from the transmitter, and path loss exponent of 3.5 and shadowing variation of 5 dB for distances larger than 5 meters. For the fading model, the Channel B model developed for small office environments and non line-of-sight conditions by TGnSync group is implemented with an rms delay spread of 15 ns and Doppler frequency of 5 Hz. In the physical layer, a practical, 2x2 MIMO configuration is assumed. OFDM parameters such as guard interval, number of subcarriers etc., are chosen according to the 802.11n specifications in [Mujtaba, 2004]. Further details of the MIMO channel can be found in [Erceg et al., 2004]. IEEE 802.11n data rates are adaptively selected from the set {24, 36, 48, 72, 96, 108, 144, 192, 216} Mbps according to the instantaneous channel conditions as explained in [Mujtaba, 2004], [Erceg et al., 2004]. The basic rate, i.e. the common rate for control packet transmission is selected as 24 Mbps. Finally, some of the MAC related parameters of the simulation model are given in Table I. The maximum number of packets allowed in frame aggregation, L , is assumed as 63. The downlink traffic is modeled by fixed size (1024 bytes) packets that arrive due to the Poisson distribution. Similar load level is assumed for all stations and increased until the network is brought to saturation. Random topologies are simulated with an AP in the middle and 12 stations uniformly distributed within a radius of 25 m.

In Figure 7 the effect of aggregation on scheduling is illustrated by comparing the throughput of three existing scheduling algorithms MRS, PFQ and LQ. Without frame aggregation, MRS shows the best performance, since the users with the better channel conditions are selected, providing the highest throughput. When frame aggregation is applied however, MRS shows the poorest performance, while LQ has the highest throughput. This is because of the fact that in MRS, the users with better channel capacities are served frequently so their queues do not fill up, resulting in small aggregate size and low throughput. With frame aggregation, the simplest queue aware scheduling scheme, LQ leverages the advantage of frame aggregation.

Parameter	Value
SIFS	16 μ sec = 16 X 10 ⁻⁶ sec.
DIFS	34 μ sec = 34 X 10 ⁻⁶ sec.
PLCP overhead	44.8 μ sec = 448 X 10 ⁻⁷ sec.
T _{IAC}	11.2 μ sec = 112 X 10 ⁻⁷ sec.
T _{RAC}	8.7 μ sec = 87 X 10 ⁻⁷ sec.
T _{BLACK}	48.7 μ sec = 487 X 10 ⁻⁷ sec.
T _{BLAR}	9 μ sec = 90 X 10 ⁻⁷ sec.

Table 1. Some MAC Related Parameters

In the following, we provide the performance analysis when frame aggregation is applied, considering our proposed queue aware throughput opportunistic schedulers AOS, ADOS and P-WF in comparison to existing algorithms LQ, MRS, PFQ, CQS, SRPT and OAR.

As depicted in Figure 8, where simulations are repeated with different topologies and the presented results are average values over ten topologies, proposed algorithms AOS and ADOS significantly outperform all the existing algorithms, e.g., by 53 % over SRPT, by 35 % over MRS, PFQ and by 21% over LQ, as they both maximize the instantaneous throughput. Our predictive block scheduler P-WF provides a further improvement of 4-5% over

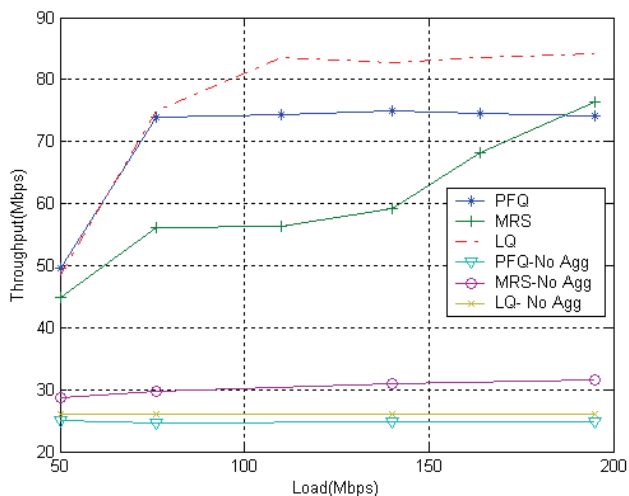

Fig. 7. Throughput of existing schedulers with and without frame aggregation

AOS/ADOS schemes, since it maximizes the throughput in the long term. Among the previous schemes, the CQS algorithm provides the highest throughput. This is followed by OAR and MRS algorithms and the SRPT algorithm exhibits the lowest throughput. In summary, proposed algorithms AOS, ADOS and P-WF provides the highest throughput as they possess the most explicit insight about the system behavior, considering the effects of the physical medium, MAC efficiency and queue states jointly. It is worthwhile to note that throughput performance of ADOS is close to AOS, implying that the algorithm can be applied after rate matching.

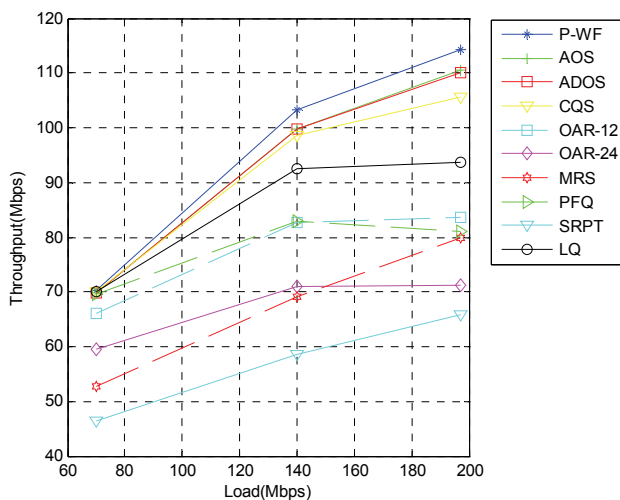

Fig. 8. Throughput of proposed and existing schedulers with frame aggregation

In order to evaluate fairness, we define an unfairness index as the ratio of the standard deviation of station throughputs to the mean throughput, i.e., $UF = \sigma / S_{av}$. It is obvious that the larger UF gets, the distribution of throughput among stations becomes more *unfair*. Using the definition of this unfairness index, a picture of the fairness performance of all algorithms under varying load has been obtained as depicted in Figure 9. SRPT and MRS algorithms show the poorest performance in terms of fairness, since they aggressively favour users with high channel capacities. The LQ algorithm is the fairest scheme as it operates like the round robin scheme providing equal access to each station. The CQS algorithm follows the LQ algorithm.

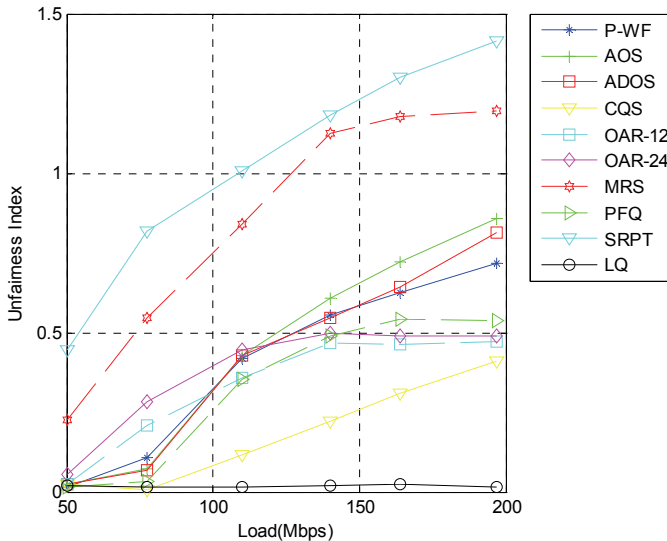

Fig. 9. Fairness performance under varying load

Fairness of our proposed algorithms remain between CQS and MRS. AOS is the most unfair among proposed schemes, since instantaneous throughput is maximized, in an opportunistic fashion. The ADOS algorithm offers slightly more fair distribution than AOS, due to the fact that quantized data rates results in increased emphasis on queue sizes, enhancing fairness. Our predictive block scheduler P-WF improves fairness further, since it considers allocation of multiple users to maximize the long term throughput.

Finally, Figure 10 depicts the MAC efficiency of each scheduler, where the actual throughput and time averaged data rates are plotted together as a function of load, again averaged over ten topologies. LQ and CQS algorithms operate with highest efficiencies, where the average throughput is close to average of physical data rates. SRPT and MRS are the most inefficient schemes, since the achieved throughput levels half or less than half of the average of selected user data rates, which are considerably high.

All our proposed algorithms provide a very good compromise between selected physical layer data rates and efficiency and our predictive block scheduler, P-WF provides the highest throughput with highest efficiency due to the main objective of long term throughput maximization.

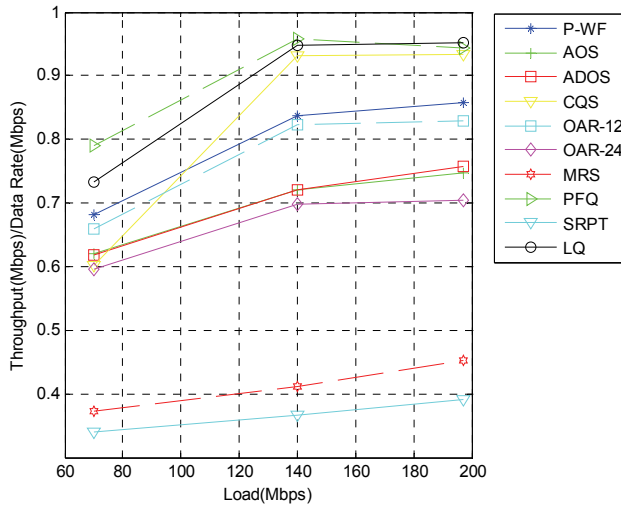

Fig. 10. Average utilization performance

5.2 Performance with relaying

In this section we analyze the effect of incorporating relaying with opportunistic scheduling and frame aggregation. Distances between the AP and destination stations, the AP and intermediate stations, and intermediate stations to destination stations define the respective data rates to be supported in between, so we analyzed relaying by varying the distances between the stations. Before presenting the results, we first demonstrate how the average supported data rates vary by the distance.

In Figure 11, for illustration purposes, we present the average physical data rates achieved for varying distances considering direct transmission and relaying (considering a relay in the middle), neglecting overhead terms. Relaying does not offer improvement for short distances since the maximum data rates are already realized by transmitting over one hop. On the other hand, as distance is increased, the direct transmission rate reduces significantly and improvement of relaying can be observed.

In our next set of simulations we have considered topologies as shown in an example configuration in Figure 12 and we have varied the inner radius, d_1 and outer radius, d_2 together, while keeping $d_2/d_1 = 2$. In the figure we show the variation of d_1 only, but the network radius, d_2 is also varied to keep the same ratio. Accordingly, both the good and bad positioned stations are effected in a similar manner in terms of the increasing or decreasing of supported data rates. Yet, the fact that they both increase or decrease does not imply that their ratio remains fixed, hence the probability of opting for relaying is expected to differ with varying distance. We again consider a network with 12 stations and one AP. The total load is set as 200 Mbps, which is evenly distributed between the stations. The algorithms AOS, CQS and LQ are compared with their counterparts aided by relaying. As explained in Section 4, the schedulers are applied using the equivalent relaying rate given by Eq. (13) for a user if it exceeds the rate of direct transmission for that user. The basic rate is selected as 12 Mbps.

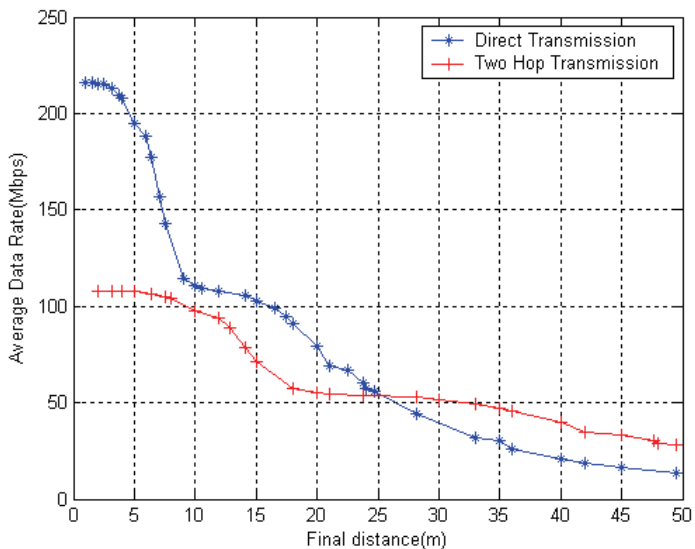

Fig. 11 Comparison of data rates for direct and two-hop neglecting overhead

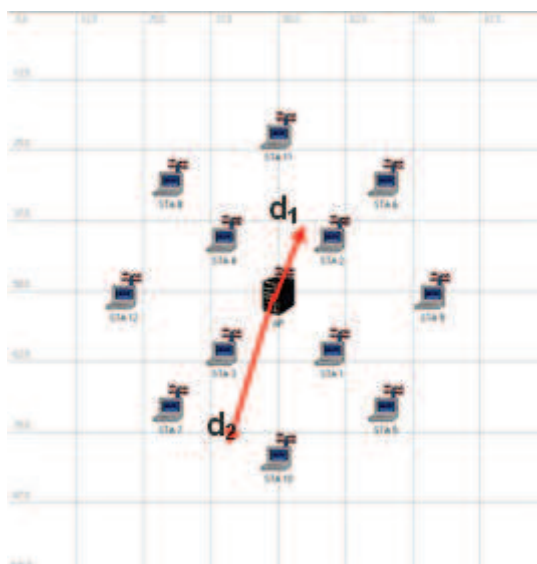

Fig. 12 Relaying topology $d_2/d_1 = 2$

As depicted in Figure 13, without relaying, the total throughput is decreased as the network radius is increased, since the supported data rates are likely to decrease for all stations. When the radius is small, the algorithms perform very similarly, since the topology is close to a uniform topology. However, the effect of distance on total throughput largely depends on the scheduling algorithm used. As the network radius is increased, AOS and CQS outperform LQ since better positioned stations are preferred more frequently. LQ yields very low throughputs, for the algorithm cannot avoid transmitting to the farther stations, even if the supported data rates are very low. This result is due to the fact that although LQ serves each user equally in terms of amount of data, the actual temporal shares of the users are significantly different. Users with very low transmission rates are served for a very long duration, reducing total network throughput drastically.

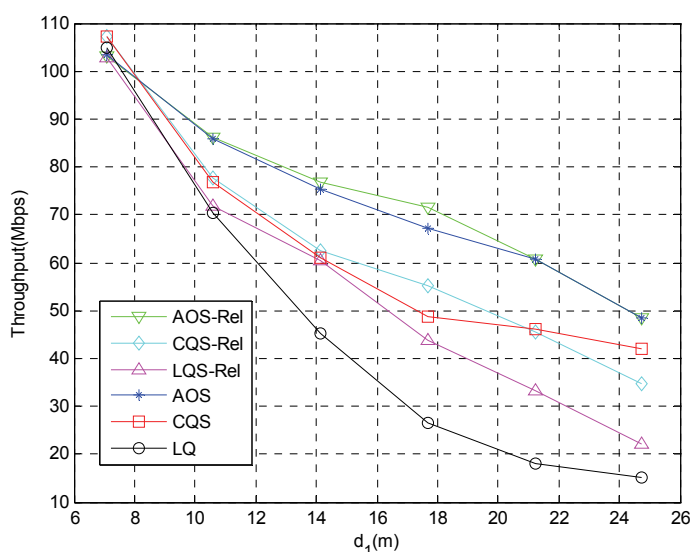

Fig. 13 Throughput with both inner and outer radius varying

As shown in Figure 13, with relaying, the performance of the LQ algorithm is significantly improved. This is because the effective service rates of the farther stations are increased, leading to an increase in throughput. For this setting, we observe that the behavior and performance of the AOS algorithm is not drastically effected by relaying: Initially, all users are supported with high rates and no relaying is selected. When network radius is increased, we see that relaying is employed since direct user rates are reduced, and relaying offers advantage for farther stations. However, as the distance is further increased, the inner stations start to be scheduled more since their queues grow, resulting in larger scheduler metrics than the farther stations. Therefore, in AOS, relaying is not exploited at all for large distances. The behaviour of the CQS algorithm is different than both LQ and AOS. With CQS, initially relaying offers an improvement for throughput, but afterwards as the network radius is increased, the increase in the relative proportion of

outer stations being selected results in an overall decrease in the throughput. Therefore, the frequency of employing relaying in CQS is not as high as LQ, but is still much higher compared with AOS.

In Figure 14 the unfairness index is plotted as a function of the distance. We see that relaying yields an increase in the capacity and enables the outer stations to gain access without growing their queue sizes (as much as the direct case), since their related scheduling metrics are increased. For AOS, fairness is slightly improved when relaying is employed, since the outer users are selected more frequently. For the CQS algorithm, we see that relaying significantly improves fairness performance since it yields increase in the capacity terms of outer stations in the scheduling metric, enabling the outer stations to gain access without having to grow their queue sizes.

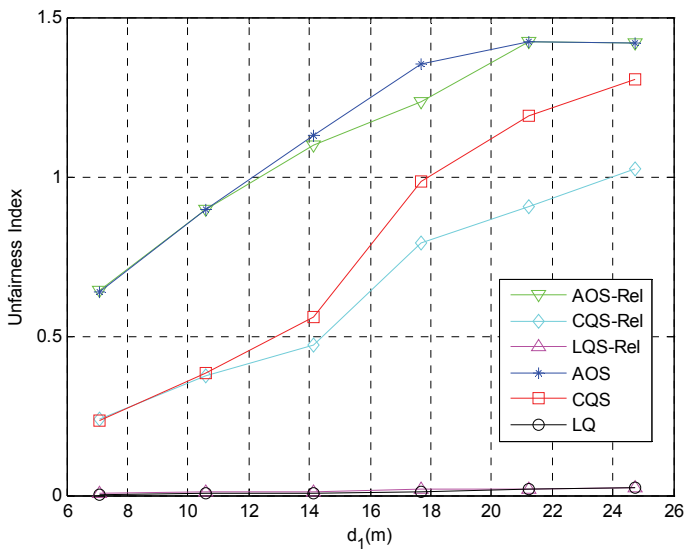

Fig. 14. Unfairness with both inner and outer radius varying

In essence, applying relaying for IEEE 802.11n improves throughput, fairness or even both simultaneously, yet the extent of improvement for opportunistic schedulers is limited by the fact that schedulers tend to give priority to users already with relatively good channel conditions.

6. Conclusions

In this work, we propose a family of scheduling algorithms for IEEE 802.11n, where scheduling decisions are based on throughput, calculated instantaneously or considering the long term evolution of user queues. We provide a performance comparison of our schemes with all outstanding algorithms from the literature considering all in the same air interface.

We show that with frame aggregation, spatially greedy scheduling algorithms such as MRS are no longer optimal for maximizing throughput performance. Even though these algorithms yield the maximum physical data rates and they would have provided the highest throughput values in an infinitely backlogged setting if there were no overhead, they all fail considerably under the 802.11n model. This is because of the fact that the observed throughput highly depends on the transmission duration as well as the overhead, especially in WLAN systems which provides improved, 802.11n rates.

Our proposed AOS and ADOS algorithms improve the throughput of such greedy opportunistic schemes, by up to 53% when aggregation is applied. Our block scheduling algorithm P-WF further improves the performance, since the statistical evolution of the queue states are considered and hence the average aggregate size and the throughput are predicted in the long term, justifying the concept that selecting the user which maximizes the instantaneous scheduling metric may not provide maximum performance throughout the entire time duration. This algorithm offers temporal shares of access, in addition to scheduling order, with allocations that provide maximized long term throughput while at the same time providing better fairness. When throughput and fairness performance are considered together, our predictive block scheduler, P-WF stands out as the best scheduling scheme that provides the highest throughput without fairness penalty.

Applying the concept of relaying is slightly differentiated from conventional relaying due to overhead. We have shown that for networks which have users located far away from the AP, relaying improves either throughput or fairness or both. Our queue aware scheduler AOS is not improved through relaying in terms of throughput as much as non-opportunistic schedulers since poor channel users are not selected frequently, but yet the performance is enhanced.

The practical implementation of our scheduling algorithms requires monitoring of the load at each user queue and the channel conditions. Hence, scheduling decisions can adapt to varying channel and traffic conditions as long as channel state information and queue states can be easily, continuously observed.

7. References

- Bianchi, G. (2000) . Performance analysis of the IEEE 802.11 distributed coordination function. *IEEE Journal Selected Areas in Communications*, 18,3, March 2000, 535 – 547.
- Bicket, J.; Aguayo, D. ;Biswas, S. & Morris, R. (2005) Architecture and Evaluation of an Unplanned 802.11b Mesh Network. *MobiCom'05*, Cologne, Germany, August 2005
- Bolcskei, H.; Gesbert, D. & Paulraj, A. J. (2002). On the Capacity of OFDM-Based Spatial Multiplexing Systems. *IEEE Transactions on Communications*, 50, 2, February 2002, 225-234.
- Boyer, J.;Falconer, D.D. & Yanikomeroglu, H., (2004). Multihop diversity in wireless relaying Channels. *IEEE Transactions on Communications*, 52, 10, October 2004, 1820-1830.

- Ciftcioglu, E.N. & Gurbuz, O. (2006). Opportunistic Scheduling with Frame Aggregation for Next Generation Wireless LANs. *IEEE International Conference on Communications (ICC) 2006*, pp. 5228-5233, Istanbul, Turkey, June 2006.
- Ciftcioglu, E.N. & Gurbuz, O. (2007). Access Scheduling Based on Time Water-Filling for Next Generation Wireless LANs. *IEEE Vehicular Technology Conference (VTC) Spring 2007*, pp.2966-2970, Dublin, Ireland, April 2007.
- Cover, T.M. & Thomas, J.A. (1991). *Elements of Information Theory*. Wiley, New York.
- Erceg, V. et al. (2004). TGN Channel Models. *IEEE 802.11 - 03/940r4*, May 2004.
- Jalali, A.; Padovani, R. & Pankaj, R. (2000). Data Throughput of CDMA-HDR: A High Efficiency-High Data Rate Personal Communication Wireless System. *Proceedings of IEEE Vehicular Technology Conference (VTC) Spring 2000*, pp. 1854-1858, Tokyo, Japan, May 2000.
- Kleinrock, L. (1975) *Queueing Systems, Volume I: Theory*. Wiley-Interscience, New York.
- Knopp, R. & Humblet, P. (1995). Information capacity and Power Control in Single Cell Multi-user Communications. *Proceedings of IEEE International Conference on Communications (ICC) 1995*, pp. 331-335, Seattle, USA. June 1995.
- Leon Garcia, A. & Widjaja, I. (2004) *Communication Networks: Fundamental Concepts and Key Architectures. Second Edition*, McGraw Hill.
- Liu, C. & Stephens, A. P. (2005). An analytic model for infrastructure WLAN capacity with bidirectional frame aggregation. *IEEE Wireless Communications and Networking Conference (WCNC) 2005*, pp. 113-119, New Orleans,, USA, March 2005.
- Mujtaba, S.A. (2004). TGN Sync Proposal Technical Specification 3. *TGN Sync Technical Proposal R00*, August 13, 2004.
- Navda, V.; Kashyap, A. & Das, S. R. (2005) Design and Evaluation of iMesh: an Infrastructure-mode Wireless Mesh Network. *IEEE Symposium on a World of Wireless, Mobile and Multimedia (WOWMOM)*, pp. 164-170, Taormina, Italy, June 2005.
- Neely, M.; Modiano, E. & Rohrs, C.(2002) .Power and server allocation in a multi-beam satellite with time varying channels," *Proceedings of IEEE Infocom 2002*, pp. 1451-1460. New York, USA, June 2002.
- Rappaport, T.S. (2002). *Wireless Communications: Principles and Practice, Second Edition*, Prentice Hall, Upper Saddle River, NJ.
- Sadeghi, B.; Kanodia, V.; Sabharwal, A. & Knightly, E. (2002). Opportunistic Media Access for Multirate Ad Hoc Networks. *Proceedings of ACM MOBICOM 2002*, 24-35, Atlanta, USA, September 2002.
- Schrage, L.E. & Miller, L.W. (1966), The queue M/G/1 with the shortest remaining processing time discipline. *Operations Research*,14, August 1966, 670-684.
- Sreng, V.; Yanikomeroglu, H., & Falconer, D.D. (2002). Coverage enhancement through two-hop relaying in cellular radio systems. *IEEE Wireless Communications and Networking Conference(WCNC) 2002*, pp. 881-885, Orlando, USA, March 2002.
- Telatar, I. E. (1999). Capacity of multi-antenna Gaussian Channels. *European Transactions on Telecommunications*, 10, 6, November 1999, 585-595.

- Tinnirello, I. & Choi, S. (2005). Efficiency Analysis of Burst Transmissions with Block ACK in Contention-Based 802.11e WLANs. *Proceedings of IEEE International Conference on Communications(ICC) 2005*, pp. 3455-3460, Seoul, Korea, May 2005.
- Zafer, M. & Modiano, E. (2005). A calculus approach to minimum energy transmission policies with quality of service guarantees. *Proceedings of IEEE Infocom 2005*, pp. 548-559, Miami, USA, March 2005

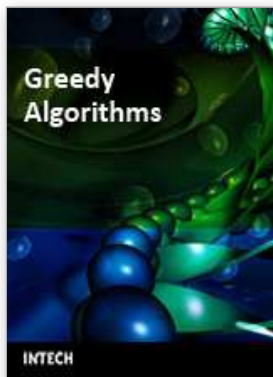

Greedy Algorithms

Edited by Witold Bednorz

ISBN 978-953-7619-27-5

Hard cover, 586 pages

Publisher InTech

Published online 01, November, 2008

Published in print edition November, 2008

Each chapter comprises a separate study on some optimization problem giving both an introductory look into the theory the problem comes from and some new developments invented by author(s). Usually some elementary knowledge is assumed, yet all the required facts are quoted mostly in examples, remarks or theorems.

How to reference

In order to correctly reference this scholarly work, feel free to copy and paste the following:

Ertuğrul Necdet Çiftçioğlu and Özgür Gürbüz (2008). Opportunistic Scheduling for Next Generation Wireless Local Area Networks, Greedy Algorithms, Witold Bednorz (Ed.), ISBN: 978-953-7619-27-5, InTech, Available from:

http://www.intechopen.com/books/greedy_algorithms/opportunistic_scheduling_for_next_generation_wireless_local_area_networks

INTECH

open science | open minds

InTech Europe

University Campus STeP Ri
Slavka Krautzeka 83/A
51000 Rijeka, Croatia
Phone: +385 (51) 770 447
Fax: +385 (51) 686 166
www.intechopen.com

InTech China

Unit 405, Office Block, Hotel Equatorial Shanghai
No.65, Yan An Road (West), Shanghai, 200040, China
中国上海市延安西路65号上海国际贵都大饭店办公楼405单元
Phone: +86-21-62489820
Fax: +86-21-62489821

© 2008 The Author(s). Licensee IntechOpen. This chapter is distributed under the terms of the [Creative Commons Attribution-NonCommercial-ShareAlike-3.0 License](#), which permits use, distribution and reproduction for non-commercial purposes, provided the original is properly cited and derivative works building on this content are distributed under the same license.