



UPPSALA  
UNIVERSITET

# **Opportunity for male mate choice? Male reproductive costs in *Sabethes cyaneus*- a mosquito with elaborate ornaments expressed by both sexes**



**Dianna Steiner**

Master of Science Thesis in Evolutionary Biology

2007-2008

Supervisors: Göran Arnqvist, Sandra South

Uppsala University, Norbyvägen 18D, 752 36 Uppsala, Sweden

## **ABSTRACT**

Mutual ornamentation may evolve through male and female adaptive mate choice, natural selection for the same trait in both sexes, or be a non-adaptive result of an intersexual genetic correlation. Both males and females of the mosquito *Sabethes cyaneus* express elaborate ornaments. *S. cyaneus* behavior and characteristics of the ornament suggest that the latter two explanations for mutual ornamentation are improbable in this case; however, adaptive choice seems plausible. This study investigated the opportunity for male mate choice in *S. cyaneus* by experimentally examining male reproductive costs. Costs were deduced by comparing the longevity of three treatment groups: (i) males allowed to engage in courtship and copulation, (ii) males allowed to court but deprived of copulation, and (iii) males deprived of both courtship and copulation. Although males suffered costs due to sexual activity, the observed decrease in lifespan was statistically non-significant. Courtship activity was negatively correlated to lifespan and although males allowed to copulate suffered the highest mortality, copulations were found to be positively correlated to lifespan. This data, combined with a low observed mating rate, suggest that copulation success could be condition-dependent. Despite the non-significant lifespan difference among male treatment groups, I believe that male reproductive costs of *S. cyaneus* may be of biological importance and I discuss potential influencing factors.

## CONTENTS

<b>1. Introduction</b>	<b>3</b>
<b>1.1 Costly, Elaborate Sexual Signals</b>	<b>3</b>
<b>1.2 Signals and Mate Choice</b>	<b>4</b>
<b>1.2.1 Mate choice evolution</b>	<b>4</b>
<b>1.2.2 Quality signaling and ornamentation</b>	<b>5</b>
<b>1.2.3 Sensory exploitation</b>	<b>6</b>
<b>1.2.4 Sex roles, mate choice, and ornamentation</b>	<b>6</b>
<b>1.2.4.1 Male mate choice</b>	<b>7</b>
<b>1.2.4.2 Sex role reversal and female ornamentation</b>	<b>8</b>
<b>1.2.4.3 Mutual sexual selection - ornaments in both sexes</b>	<b>9</b>
<b>1.2.4.3.1 Alternative explanations for ornaments in both sexes</b>	<b>10</b>
<b>1.3 Sabethine Mosquitoes: a Tribe Exhibiting Ornaments in Males and Females</b>	<b>12</b>
<b>1.3.1 Possible explanations for male and female ornamentation in <i>Sabethes cyaneus</i></b>	<b>13</b>
<b>1.3.2 Exploring male mate choice in <i>S. cyaneus</i></b>	<b>15</b>
<b>2. Methods</b>	<b>15</b>
<b>2.1 Study Population and Maintenance</b>	<b>16</b>
<b>2.2 Experimental Design</b>	<b>17</b>
<b>2.2.1 Treatment study- method and efficacy of female manipulation</b>	<b>17</b>
<b>2.2.1.1 Objectives</b>	<b>17</b>
<b>2.2.1.2 Female manipulation method</b>	<b>18</b>
<b>2.2.1.3 Experimental design</b>	<b>19</b>
<b>2.2.1.4 Data analysis</b>	<b>20</b>
<b>2.2.1.5 Results</b>	<b>21</b>
<b>2.2.1.6 Conclusions</b>	<b>22</b>
<b>2.2.2 Main study methods</b>	<b>22</b>
<b>2.2.3 Statistical and graphics software</b>	<b>23</b>
<b>3. Results</b>	<b>23</b>
<b>3.1 Male Mating Rates</b>	<b>23</b>
<b>3.2 Courtship Behavior</b>	<b>24</b>
<b>3.3 Male longevity</b>	<b>26</b>
<b>3.4 Courtship effort over time and its affect on male lifespan</b>	<b>27</b>
<b>4. Discussion</b>	<b>31</b>
<b>Acknowledgements</b>	<b>35</b>
<b>Appendix</b>	<b>36</b>
<b>References</b>	<b>37</b>

## 1. INTRODUCTION

### 1.1 Costly, Elaborate Sexual Signals

The remarkable eye span of the stalk-eyed fly (*Teleopsis dalmanni*) seems at once impressive and absurd (Figure 1a). What could possibly be the advantage of having eyes projected on stalks to the extent that they are more than a body length apart? Equally marvelous is the extreme and varied array of dazzling ornamentation in the birds of paradise (Paradisaeidae; Figure 1b-f). However, the variety of plumage ornaments exhibited by this group of birds is only a glimpse into the immense range of ornaments, traits and behaviors found in nature; conspicuous and bizarre morphological and behavioral traits are found throughout all taxa. Characteristics such as these surely cannot improve the chance of survival; in fact many seem to be disadvantageous. And yet these traits are capable of evolving rapidly (Andersson 1994) as illustrated by closely related species which exhibit radical differences in ornamentation (cichlid fishes, pheasants, Hawaiian fruit flies, Andersson 1994; beetles Emlen 2001; Arnqvist and Rowe 2005; fruit flies Aluja and Norrbom 1999). Even just recently isolated populations may show divergence in ornaments (passerines, Yeh 2004). However, elaborate traits are certainly costly in terms of the energy required to produce and maintain them, their conspicuousness to predators and often even restrict mobility (Andersson, M. 1994, Andersson, S. 1994, Gwynne *et al.* 2007). What pressure could promote the rapid evolution and divergence of these apparently unnecessary and costly traits? What could be their function?

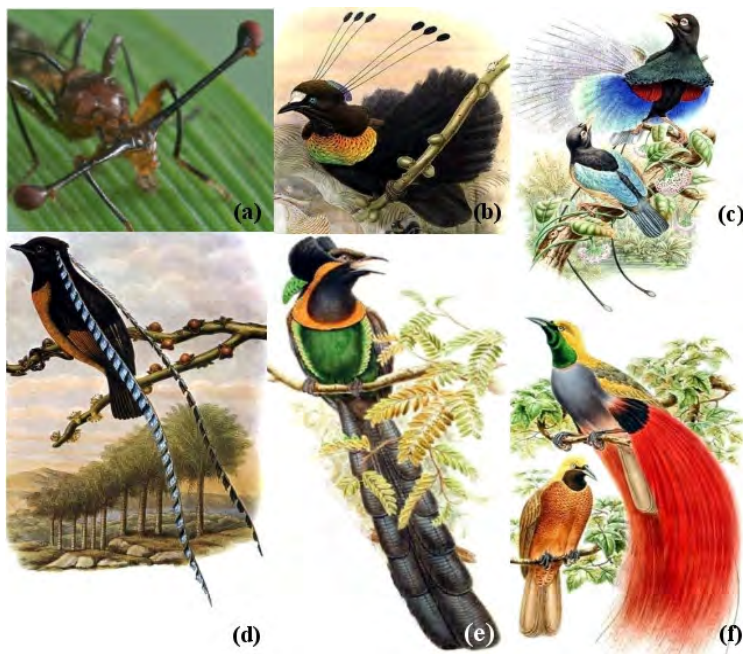

Figure 1. Many organisms exhibit ornaments which appear to have no function for survival. Eyes of the male stalk-eyed fly (a) may be more than a body length apart and birds of paradise (b-f) show great diversity in their plumage.

Darwin was the first to tackle the conundrum of these varied and elaborate traits. In “On the Origin of Species” (1859) he mused the ubiquity of male armaments across taxa and attributed them “to the struggle between the males for possession of the females.” Darwin maintained that sexual dimorphism stems from “individual males having had, in successive generations, some slight advantage over other males, in their weapons, means of defen[s]e, or charms; which they have transmitted to their male offspring alone.” Darwin set us down the right track; we now recognize these conspicuous and seemingly superfluous traits as signals employed to increase one’s number of matings, ie. they are sexually selected.

Sexual signals may function in an individual’s attempt to, in Darwin’s (1871) terminology, “fight” or “charm” conspecifics. “Fighting” is intrasexual competition for resources such as prime breeding territory or for access to mates whereas traits adapted for “charming,” or intersexually selected traits, function in interactions with potential mates. Individuals exhibit intersexual signals in an attempt to influence potential mates to choose them over other individuals, potentially elevating the reproductive success of the signaler (Andersson 1994). The preference for some individuals over another is known as mate choice. The next section describes the role of mate choice in the evolution and maintenance of sexual signals.

## **1.2 Signals and Mate Choice**

Variation is the core of evolutionary processes, of both natural and sexual selection. If all potential mates were of the same genetic quality and would invest the same amount of resources into reproduction or care of offspring, there would be no advantage to choose one individual over another. Of course, individuals do vary; one may host less parasites, express slightly more cryptic coloration, be a more efficient forager, produce a greater amount of eggs or a larger more nutritious and sperm-laden spermatophore. Under adaptive mate choice, an individual should prefer a mate whose specific combination of traits will most increase his or her reproductive success (Andersson 1994).

### **1.2.1 Mate choice evolution**

The relative parental investment of the sexes in offspring, beginning with anisogamy or differential gamete size, is key to the evolution and maintenance of choosiness and competition within a species (Bateman 1948, Trivers 1972). The sex which invests considerably more in reproduction and care of the offspring should benefit more from choosing amongst variable potential mates. The sex which invests less, on the other hand, should be able to mate more with less cost and therefore be indiscriminate and compete to copulate with as many mates as

possible. Because females invest more in offspring from the outset, they are most often the limiting sex (Bateman 1948). Skew in the operational sex ratio (OSR), due to a limiting sex, was long considered sufficient to maintain the opportunity for mate competition and mate choice. More recently, however, evidence for the importance of other variables is accumulating. In fact, Kokko and Monaghan (2001) found that cost of breeding was of greater importance than OSR, albeit they recognized that the two variables can be tightly correlated. Reproductive costs include the various costs of mating (e.g., increased predation risk, energetic costs, and risk of contracting parasites and/or pathogens; Daly 1978, Arnqvist and Rowe 2005) as well as the costs of gamete production and parental care (Bateman 1948, Trivers 1972). The costs of reproduction vary between the two sexes and by mating system (Daly 1978). It is important to note, however, that the cost of mating is not necessarily a by-product of evolved mating systems but indeed, is one of the influencing forces creating the spectrum of mating systems we find in nature (Emlen and Oring 1977). It is now widely accepted that the evolution and maintenance of adaptive mate choice does not depend on the OSR and mate variation alone. Quite simply, there must be a net gain in order for choosiness to benefit an individual and evolve in a mating system (Parker 1983, Bonduriansky 2001).

Reproductive benefits of choosiness, or selecting a high-quality mate, may be gained directly or indirectly. Direct benefits from choosing a high-quality mate may come in the form of direct resources, such as territory quality, nuptial gifts, parasite or pathogen avoidance or parental care. Indirect benefits are genetic qualities not enjoyed by the choosing individual but by her or his descendants. These indirect benefits are “good genes” (genotype well-adapted to the current environment or with greater viability) or genetic compatibility i.e, inbreeding avoidance (Andersson 1994).

### **1.2.2 Quality signaling and ornamentation**

Signals allow an individual to assess the benefits they stand to gain from a potential mate. Characteristics without physical manifestations, i.e. parental effort, may be signaled by evolved and correlated “arbitrary” traits. Preferred traits tend to be correlated to some property relating to the potential mate’s quality. Here, quality is loosely defined as any property which may directly or indirectly affect the reproductive success of the choosy sex (Halliday 1983). Hence an ornament may signal any number of characteristics which will affect the reproductive success of the choosy sex. The tail length of male swallows (*Hirunda rustica*) inversely reflects parasite load and females in turn prefer males with longer tails (Møller 1988 and 1992).

In order for mate choice through the assessment of sexual signals to confer benefits to the choosing sex, they must be honest indicators of quality (Johnstone and Grafen 1993). Deceitful

signaling (signaling greater quality than an individual actually possesses) is restricted by selection for the signal receiver to accurately assess the signal and there are often physiological constraints on signal expression as well. Zahavi's (1975) handicap principle, states that signals which are costly to produce will minimize misleading advertisement. Individuals of inferior quality will benefit less or even suffer a net loss of fitness from producing a costly and deceitful signal, while higher quality individuals could gain a net benefit. Related to this theory, there is extensive evidence that many sexually selected traits are condition-dependent (Johnstone 1993, Andersson 1994, Duckworth *et al.* 2004). Expression of stalk-length (a sexually selected elaborate trait) in male stalk-eyed flies varies in response to environmental stress across genotypes (David *et al.* 2000). Some genotypes exhibit decreasing eye span in progressively nutrient poor environments whereas other genotypes suffer only slightly decreased eye span in low resource environments. In this case, the cost of expressing eye span forces honesty in male signaling: although males with a "superior" genotype will have a greater eye span than males with "inferior" genotypes in any environmental condition, in poorer conditions even "superior" males will suffer a decreased eye span. Yet, there are cases where signals clearly do not honestly signal quality.

### **1.2.3 Sensory exploitation**

Krebs and Dawkins (1978, in Sivinski 1997) dubbed sexual signal traits "organs of propaganda," evolved to communicate with and manipulate prospective mates and/or sexual adversaries. There is evidence that individuals can take advantage of an innate or predetermined preference in the opposite sex in order to gain matings: sensory exploitation. The benefit to the "choosy" sex may not be apparent and they may even suffer considerable costs (Arnqvist 2006). The male water mite, *Neumania papillator*, takes advantage of the female prey response in order to increase his mating success (Proctor 1991 and 1992). A "courting" male creates vibrations on the water surface that are comparable to those that prey items emit. The female clasps the male just as she would respond to prey assuming a position which increases the probability of fertilization success. Avoidance of this manipulative behavior would be costly for the female to avoid unless she could readily distinguish a deceitful male from potential prey. Any reduction in the female water mite's response to male water vibrations could seriously decrease her nutrient intake.

### **1.2.4 Sex roles, mate choice, and ornamentation**

The conventional mating system models consist of showy males competing vigorously amongst themselves in order to procure mate opportunities with less conspicuous and more

discriminate females. However, there is growing evidence that sex roles may not be as discrete as previously thought. As discussed previously, parental investment, cost of mating, OSR, and other factors influence the sex roles which we in turn use to describe mating systems. Due to these influencing factors, which may change over time, sex roles and mating systems are not evolutionarily static. Environmental factors are known to greatly influence sexual selection, and so changes in the environment can cause shifts in mating strategies (Emlen and Oring 1977). Therefore, the mating system of a species may shift over time, sometimes relatively rapidly (Arnqvist and Rowe 2005), mating strategies may differ between or within populations (Halliday 1983, Kamler *et al.* 2004, Kitchen *et al.* 2006, Hankison and Ptacek 2007) and even change for individuals over time (Engqvist and Sauer 2002). Although mating systems may not be so discrete in nature, they can be broadly categorized as monogamy, polygyny, polyandry, and promiscuity and defined by mating relationships between males and females. Monogamy: exclusive mating relationship between one male and one female; polygyny: one male mates with multiple females; polyandry: one female mates with multiple males; promiscuity: males and females both mate with multiple partners.

#### **1.2.4.1 Male mate choice**

There are situations where mating system and high male reproductive investment can lead to males being choosy. Bonduriansky (2001) extensively reviewed male mate choice theory and empirical studies (with a focus on insects) and synthesizes a basic model for the evolution of male mate choice. I will use this model as a cornerstone for the following discussion of male mate choice.

Three factors and their interactions comprise the basic model: mate quality variance, mating investment, and constraints on choosiness. I briefly discussed mate quality variance above; variation in potential partners is the root of potential benefits of mate preference. Female mate quality may be simplified to two attributes: fecundity and genetic quality. The relative importance of these characteristics depends on the mating system. In promiscuous systems, quantity of offspring is likely more variable than quality and so female fecundity is expected to play a more important role in male preference. Therefore, males should prefer females who indicate higher fecundity (body size or current reproductive condition) rather than costly displays which advertise genetic quality (ornaments). However, the contrary is found in systems in which males may mate with only one or few females and invest heavily in offspring. Female genetic quality may play a more important role if males engage in long-term associations with a single female or if the number of different potential mates is low. Bonduriansky (2001) notes that in a mating system of combined monandry and polygyny,



which is typical for mosquitoes (Yuval 2006), genetic quality of the female may weigh heavily on the male's reproductive success. Males can mate multiply, but as females mate only once, the number of receptive females available to inseminate may be low. This situation should reward male preference for females who indicate high genetic quality. Yet, if receptive females are sufficiently scarce, choosiness is unlikely to benefit males.

The second factor of the basic model is mating investment. Males may endure costs from diffuse mating investments which aim to increase reproductive output in general (i.e. competition for territory or costly displays which are not directed toward specific females) and/or they may invest in efforts per copulation (nutrient provisioning, competition for a specific female). It is the latter costs which reduce the male's investment capability for future potential copulations and influence male mate preference. If each mating event reduces the male's future copulation opportunities, he should allocate his limited resources optimally: choose the highest quality mate possible to sire his offspring (Dewsbury 1982, Petrie 1983). Male reproductive costs can consist of high investment in nuptial gifts (Engqvist and Sauer 2002, Vahed 2007), ejaculate nutrients or amount (Dewsbury 1982, Birkhead and Møller 1998), disease and parasite transmission, increased predation risk, energy and time spent displaying, calling, courting, or during the act of copulation, and post-copulatory costs such as parental care of offspring.

The third factor of the basic model addresses the constraints of male mate choice: the costs of searching for high quality mates and the accurate assessment of these potential partners. Search costs are incurred through a low encounter rate of potential mates/receptive females or intense competition for mates (Parker 1983, Petrie 1983, Bonduriansky 2001, Servedio and Lande 2006, Härdling 2008). Cost of accurate quality assessment is due to the energetic investment of the assessment mechanism and the losses suffered by inaccurate mate assessment (i.e. mating with a low-quality female or rejecting a high-quality partner; Parker 1983, Johnstone *et al.* 1996, Johnstone 1997). In summary, male preference is expected to prevail when potential mates vary in quality (differences in any factors which influence reproductive success), mating is costly (Petrie 1983, Johnstone *et al.* 1996, Kokko and Johnstone 2002, Härdling 2008), and the benefits outweigh the costs of search and assessment. In such cases, male mating preference could select for exaggerated female traits which represent female quality.

#### **1.2.4.2 Sex-role reversal and female ornamentation**

Female ornamentation is thought to be constrained because of the relatively high female parental investment in offspring (Trivers 1972); resource investment in an ornament is traded

against provisioning directly or indirectly into offspring, hence reducing fecundity (Fitzpatrick *et al.* 1995). However, elaborate female ornamentation does exist, albeit at a much lower frequency than seen in males. In the few reported cases, female ornamentation appears to accompany full sex-role reversal: females occupy the competitive position and males choose amongst females. Here, the pressures inducing female ornament evolution are considered to be equivalent to those associated with male ornamentation in conventional mating systems. The female of the sex-role reversed long-tailed dace fly (*Rhamphomyia longicauda*) aggregates in competition swarms and display ornamental leg scales and an inflated abdomen sac which are believed to exaggerate body size as well as be related to fecundity (Gwynne *et al.* 2007). Accordingly, the unornamented males prefer large females (Funk and Tallamy 2000, LeBas *et al.* 2003). Servedio and Lande (2006) found theoretical support in the terms that male choosiness can evolve and be maintained if the preferred female trait is correlated to fecundity (discussed in more detail below). It is reasonable then to expect that even in mating systems which appear conventional, the non-limiting sex (typically males) could express mate preference in certain circumstances. Indeed, empirical studies encompassing a wide variety of taxa and mating systems have found evidence of male mate preference for female traits that appear to be related to female fecundity (sand lizard, Olsson 1993; salamander, Verrel 1995; mosquitofish, Bisazza *et al.* 1989; zebra finch, Jones *et al.* 2001; fiddler crab, Reading and Backwell 2007).

#### **1.2.4.3 Mutual sexual selection - ornaments in both sexes**

Theoretically, the mutual selection argument of monomorphic ornamentation is well supported. Servedio and Lande (2006) modelled the possibility of maintaining male preference in both polygynous and mutual choice mating systems. The authors found that male choice can persist if males with preference have increased overall courtship output. However, when male and female traits are pleiotropic (genetically linked) male preference can be maintained even without increased courtship output i.e., the female trait could be arbitrary. Still, a meta-analysis of studies investigating correlations of fitness and ornamentation suggests that mutual ornamentation generally includes an aspect of fitness signalling (Kraaijeveld *et al.* 2007). This concept is intuitive when one considers systems in which the sexes have similar parental roles; when male and female investment in offspring is nearly equal, both sexes may compete for mates and express preferences for potential partners (Trivers 1972, Andersson 1994).

Several species of socially monogamous birds, which exhibit similar parental investment between the sexes, provide support for female ornamentation maintained by male choice (Jones and Hunter 1999, Kraaijeveld *et al.* 2004). The black swan, *Cygnus atratus* (Figure 2a), pairs

assortatively depending on ornamental feather abundance. The curled feathers (Figure 2a, inset) are conspicuously exhibited during threat displays and mating pairs with more ornamental feathers procure and maintain preferred feeding grounds which leads to increased offspring survival (Kraaijeveld *et al.* 2004). Similarly, the length of ornamental feathers in the crested auklet, *Aethia cristella*, (Figure 2b) is strongly correlated to male and female mate preference as well as dominance within both sexes (Jones and Hunter 1999).

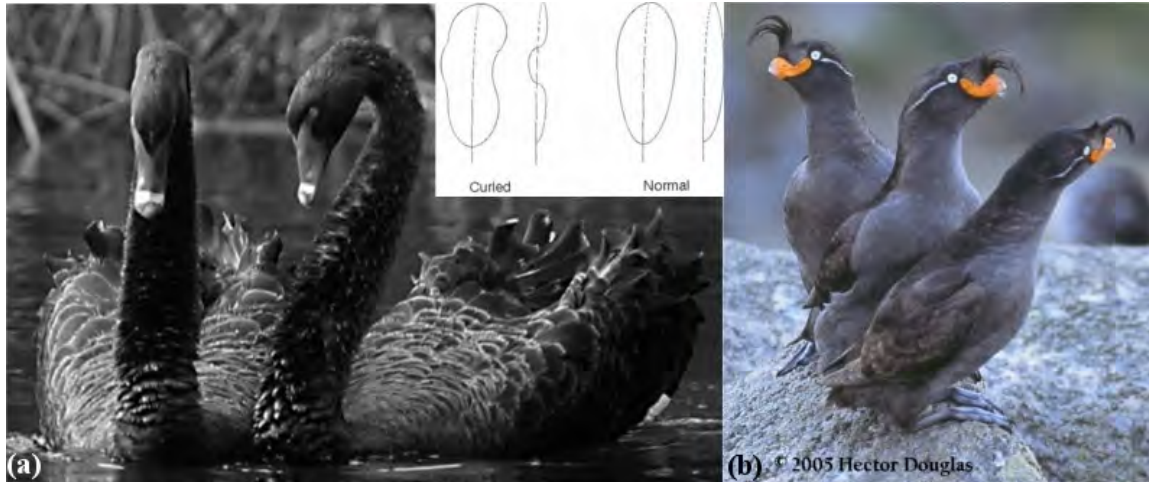

**Figure 2.** (a) The black swan (*Cygnus atratus*) pairs assortatively by abundance of ornamental wing feathers (inset); (b) The ornamental feathers of the crested auklet (*Aethia cristella*) are positively correlated to female and male mate preference

Unfortunately, empirical work investigating mutual ornamentation is limited and is greatly dominated by avian studies, especially socially monogamous birds with biparental care: 26 of the 30 studies included in the meta-analysis by Kraaijeveld *et al.* (2007) investigated various bird species. Investigations of mutual ornamentation in other taxa and those without parental care could provide significant insights into the pressures, costs, and benefits of mutual ornamentation.

#### *1.2.4.2.1 Alternative explanations for ornaments in both sexes*

The evolution and maintenance of sexually monomorphic ornamentation may not result from mutual sexual selection. Rather it may be a non-adaptive consequence of an intersexual genetic correlation (Lande 1980) or be due to direct natural selection for the trait in both sexes (Lande 1980, Johnstone *et al.* 1996, Amundsen 2000, Kraaijeveld *et al.* 2007).

The genetic correlation argument states that monomorphic ornamentation is observed due to phylogenetic inertia: a non-adaptive ornament is observed in one sex due to selection on the

trait in the other sex (Trail 1990). However, due to the cost of expressing a non-functional trait and given evolutionary time, expression of the ornament will become sexually dimorphic (Lande 1980). Although genetic correlation has long been considered the primary cause of monomorphic traits (Darwin 1859 and 1871, Lande 1980) there is little empirical work to support this theory. Kraaijeveld *et al.* (2007) contend that genetic correlation should rarely be the sole cause or maintainer of mutual ornamentation, especially when the trait is expressed to the same degree in both sexes, because taxa shift between mutual and sexually dimorphic trait expression with apparent ease. In addition, Kraaijeveld and Reumer (in press) assert, based on a comparative phylogenetic study including a wide range of animal taxa, that Lande's (1980) model does not, in general, explain mutual ornamentation in extant taxa. The authors did, however, find evidence for a role of developmental threshold mechanisms (i.e., ornaments mediated by environmental cues such as hormone levels. Under this premise, even maladaptive ornaments may evolve and only disappear when either the environmental cue disfavors expression or when the organism has evolved resistance to the environmental cue.

Evidence for direct selection on female ornamentation is quickly accruing (Amundsen 2000, Kraaijeveld *et al.* 2007). Direct selection may take the form of social selection (in competition over resources) or selection for sexual ambiguity (Burley 1981). Mutual ornamentation arising from social selection is fairly intuitive: competition for non-sexual resources are likely to be similar in both sexes and so traits functional in social competition are likely to be sexually homologous due to the same selection pressures (West Eberhard 1979, 1983). Indeed, Kraaijeveld *et al.* (2007) found that elaborate monomorphic ornaments can function as status symbols in social competition. However, this theory of selection for mutual ornamentation has been investigated to a limited extent, likely due in part to a lack of suitable model systems. Selection for sexual mimicry has received even less attention in both the theoretic and empirical realms. Burley (1981) suggested that in certain circumstances both males and females may benefit from sexual ambiguity in order to avoid costs stemming from intra- and intersexual conflicts. Several studies have shown that sexual vagueness allows individuals to avoid harassment (Galan 2000, Langmore and Bennet 1999). However, sexual mimicry in mutually ornamented species has yet to be documented.

Comparative phylogenetic studies provide evidence of contributions from both genetic correlation and adaptive evolution for ornamentation in both sexes (Ord and Stuart-Fox 2005, Kraaijeveld and Reumer [in press]) Such studies give insights into the evolution and maintenance of mutual ornamentation, however, experimental manipulation of model organisms could be invaluable in deciphering the underlying causes, benefits, and costs of

sexually mutual ornamentation. Here I introduce an invertebrate system suitable for such lab experiments which expresses sexually monomorphic ornamentation.

### **1.3 Sabethine Mosquitoes: a Tribe Exhibiting Ornaments in Males and Females**

The tribe Sabethini (Diptera: Culicidae) is prominent among mosquitoes with their brilliant metallic scales, iridescent coloration and elaborate ornaments. Perhaps the most impressive morphological traits of this tribe occur in the subgenus *Sabethes*. Species in this group exhibit elongated tarsal scales which create paddle-like structures (Hancock *et al.* 1990a). The species differ in the number of legs with paddles and in their coloration; the variation in ornamentation within this group suggests that sexual selection is a likely force in their evolution and maintenance (Andersson 1994, Pomiankowski and Iwasa 1998). Yet the typical mosquito mating system is thought to exclude opportunity for any considerable amount of sexual selection by mate choice (Hancock *et al.* 1990a). Mosquitoes generally mate eurygamously (i.e., in flight), with anywhere from several to a few thousand males swarming together and females entering the swarm to mate (Becker *et al.* 2003). These swarming masses are typically the arena for scramble competition polygyny in which males locate females by their specific wing-beat frequency (Belton 1974) and courtship and mate choice are seemingly absent (Hancock *et al.* 1990a). In addition, most mosquitoes lack secondary sexual traits, are active at dusk or night, and accordingly, appear to have eyes evolved to optimize host-seeking in low-light conditions not fine-scale discrimination of color and shape (Kawada *et al.* 2005).

Sabethines, however, diverge from this generality: they are diurnal and have eye adaptations similar to higher order dipterans which rely more on vision (Land *et al.* 1999). Moreover, sabethines do not form eurygamous mating swarms but instead copulate on substrate. Females rest on perches and males approach and attempt to align with them and mate. The stationary position of females requires that males locate them without the aid of wing-beat frequency. Diurnal activity accompanied by eyes adapted to daylight vision suggest that sabethines may rely on visual cues much more than their drab relatives (South 2007). This suggestion is corroborated by the diverse brilliant morphology and the observation of complex courtship involving prominent displays of leg ornaments in at least four species of the genus *Sabethes*.

The courtship and ornament function of *S. cyaneus* has been investigated to a greater degree than others in the group. The ornaments of this species are iridescent with blue and purple coloration and expressed only on the mid-legs (Figure 3b). *S. cyaneus* seems to adhere to a conventional mating system in which the ornamented males vie for the opportunity to mate with discriminating females. Males align with perched females and engage in a complex

courtship which includes waving the ornamented mid-legs in front of the female. Males can be knocked off the perch by competing males and the courted female. Females must accept the male in order for copulation to occur and they can reject the suitor by kicking until he loses his grasp and falls from the perch. Female choosiness is further justified as the females mate only once per lifetime (South and Arnqvist, in press). However, a closer look at this “conventional system” reveals a more complex situation: although they do not engage in courtship displays, females also possess paddle-like ornaments which are actually proportionately larger than the males’ (South and Arnqvist, unpublished; Figure 3a). Could sexual selection via mate choice be acting on females as well as males? Does paddle size or coloration denote social ranking or genetic quality? Perhaps the colorful ornament is merely an instrument integral for flight?

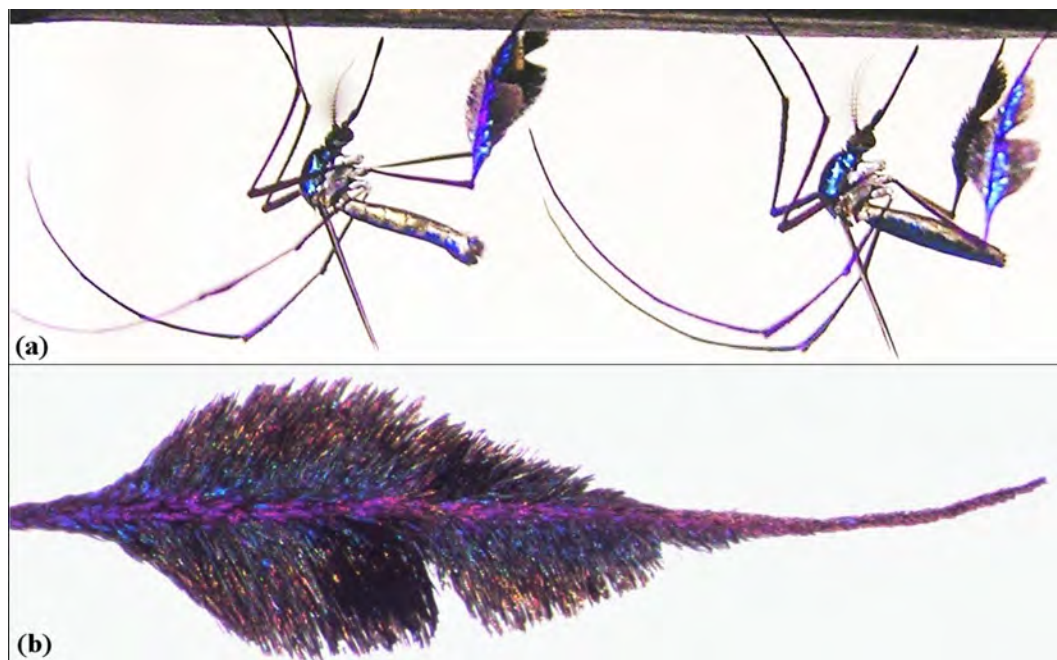

Figure 3. (a) Male and female *Sabethes cyaneus* (shown on the left and right respectively) both express ornaments on their mid-legs; (b) the paddle is made up of elongated tarsal scales

### 1.3.1 Possible explanations for male and female ornamentation in *Sabethes cyaneus*

Here I will discuss *S. cyaneus* ornamentation in the context of previous studies and contemporary theory in order to elucidate the possible candidates responsible for mutual ornamentation in this species: natural selection for flight ability, genetic correlation, sexual ambiguity, social or intrasexual selection, and/or mutual mate choice.

Hancock *et al.* (1990b) found that removing paddles from males and females did not affect flight. This provides evidence against natural selection for flight ability, which is further corroborated by the striking diversity of the number, elaboration, and coloration of leg paddles in closely related *Sabethes* species.

An explanation based purely on a genetic correlation also seems improbable. The paddles are both large and iridescent; developmental or energetic costs of expressing the paddle or increased predation risk would seemingly select against paddle expression in females. It could be that not enough time has elapsed for selection to remove expression in females, however, the fact that female paddles are expressed to a greater extent than male paddles does not suggest that female paddles are in the process of being lost.

The theory of selection for sexual ambiguity seems equally unlikely for two reasons. First, sexual ambiguity could be maintained under frequency dependence with several morphs of a sex present in the population. The presence of at least two morphs keeps the aggressive sex from adapting and forming a new search image of the opposite sex. *S. cyaneus* females do not occur in morphs. Secondly, males court and attempt to mate with males as well as females. If sexual ambiguity evolves to afford females relaxed sexual aggression from males, this “ambiguity” in *S. cyaneus* should be selected against since looking like a male does not offer females respite. It also seems unlikely that selection for females to appear like males would have induced expression of female paddles even larger than those of males. However, an “arms race” between the sexes could be invoked to explain sexual ambiguity: females who have most perfected “maleness” escape sexual aggression and males with the greatest ability to differentiate sexes gain more matings.

Although this species has not been observed extensively in nature, it does not appear to display social ranking, dominance contests, or competition for access to non-mate resources. Neither males nor females seem to compete for preferred perch sites or for access to food sources. No behaviors that could be construed as female contest competition have been observed. It is therefore unlikely that social or intrasexual competition is responsible for female ornamentation.

The final possibility for the evolution and maintenance of *S. cyaneus* mutual ornamentation is sexual selection through mate choice acting on both sexes. This theory seems the most plausible as there is apparent opportunity for both sexes to engage in mate choice. As they patrol perches, males may assess potential mates and could then preferentially align with the highest quality individuals. Females may evaluate their suitors during the extensive and complex courtship as males wave their paddled legs in front of the female. Males may also use courtship for further assessment of the female and both sexes could potentially exploit a

suspected tactile component to assess the potential mate (see Appendix 1 for a description of courtship behaviors).

Hancock *et al.* (1990b) suggested that paddles are involved in female mate attraction as females with their paddles removed were inseminated significantly less than females with paddles left intact. These ornaments are not, however, essential to male reproductive success (males with paddles removed inseminated the same number of females as males with paddles). However, the study did not investigate the female acceptance or rejection rate of paddle-less males, but merely determined successful insemination after a period time. It could well be that females were less willing to mate with paddle-less males but copulated after persistent courtship; the insemination rate may obscure a true female preference. The study was suboptimal in design; paddles were either intact or removed, no intermediate or enlarged ornaments were included nor was there opportunity to choose among potential mates with differential paddle size. However, the Hancock *et al.* (1990b) study offers two important implications based on the greatly decreased insemination rate of paddle-less females. First, males take notice of the female ornament and second, ornamentation is the sole recognition trait involved in reinforcement against hybridization, or more properly, for assessing genetic compatibility. The question remains whether males actually express a mate preference based upon the leg paddle.

### **1.3.2 Exploring the possibility of male mate choice in *S. cyaneus***

The present study examined male mating costs in *Sabethes cyaneus* in order to determine whether the opportunity for male mate choice, according to prevailing mate choice theory, exists in this mating system. Females of this species mate only once (South and Arnqvist, in press) whereas male mating strategy is undocumented. I therefore wished to determine: (1) whether this species is monogamous or whether males mate multiply and (2) the costs of reproduction for males. Although there are many potential costs of reproduction, this study sought to determine the relative energetic costs of courtship and copulation incurred by males.

## **2. METHODS**

Here, I first describe a treatment study which developed methodology necessary for the main experiment and then I introduce the methods used in the main study. Individuals in both experiments were from the same population and housing of individuals was the same in both experiments unless otherwise noted.



## 2.1 Study Population and Maintenance

The *S. cyaneus* population used in this experiment came from a strain established in December 1988 by R. G. Hancock and W. A. Foster (Ohio State University, U.S.A.) from multiple individuals collected from the Isla de Maje, Lago Bayano, Panama, Republic of Panama. The colony of the present study was established from this strain in April 2006 at Uppsala University, Sweden by Göran Arnqvist and Sandra South. The colony has been maintained at  $26 \pm 1$  °C, 78-82% relative humidity and a 12L:12D photoperiod, at a population size of approximately 400 individuals. The colony is housed in two clear plastic terraria ( $59 \times 48.7 \times 29.5$ cm) each of which contain: multiple horizontal perches, an egg cup, and honey-soaked sponges and deionized water wicks serving as respective food and water sources. The egg cup is a black lidded plastic container (173ml) with a hole (1.6cm diameter) in the center of the top surface. It is half-filled with deionized water with ca.  $1/8^{\text{th}}$  teaspoon crushed flake fish food. Eggs are collected and the egg cup replaced weekly. Females require a blood meal in order to lay eggs and this is provided by inserting a human arm into the colony tank. The colony females are offered a blood meal every two days to once every couple weeks- more often when more individuals are desired, i.e. during an experiment, less often for population maintenance. Females generally oviposit eggs into the egg cup approximately one week from the time of bloodfeeding. Larvae, collected from both the main colony tank egg cups, are reared in plastic trays ( $21.5 \times 14.5 \times 5$ cm) containing deionized water filled to 2.5 cm. The water is changed weekly at the time of feeding. Larvae are provided a diet of crushed flake fish food *ad libitum*. Pupae are collected in plastic dishes (2.5cm height, 8cm diameter) filled with deionized water and are placed in the main colony tanks for adult emergence. For the present studies, pupae dishes were placed in a smaller terrarium with an *ad libitum* supply of honey and water. Emerging adults were collected from these terraria every 24 hours and the sexes housed separately. This ensured that all individuals were virgins as the male genitalia rotate more than 24 hours post-emergence (Becker *et al.* 2003). The small terraria design is shown in Figure 4. Housing of emerged adults is described below in Experimental Design- Main Study.

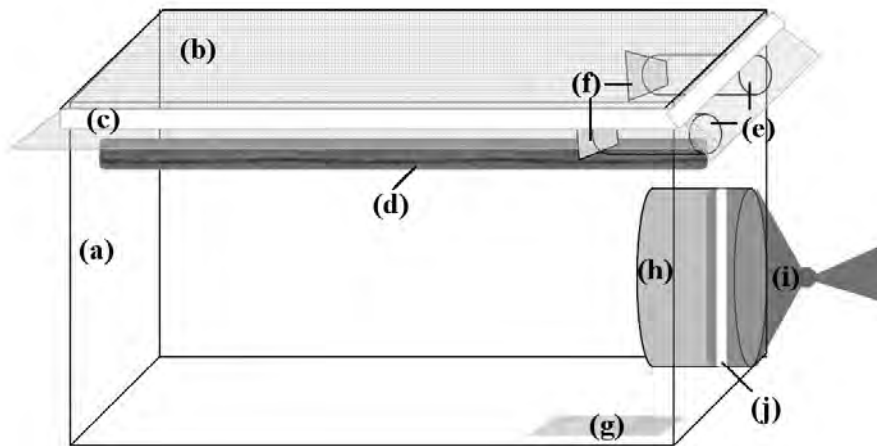

Figure 4. Small terrarium design. (a) plastic container 29x17.5x18 with an open top; (b) 1mm fabric mesh; (c) elastic; (d) perching stick; (e) 12.4ml vials; (f) sponges, soaked with either honey or water; (g) paper towel to catch dripped honey; (h) PVC pipe to line opening; (i) nylon stocking, shown here knotted to seal opening; (j) elastic

## 2.2 Experimental Design

In order to determine some of the possible male costs of reproduction I chose to examine the affects of courtship and copulation on male lifespan. The relative costs of courtship and copulation were deduced using a simple experimental design with three male treatment groups: 1. males allowed to both court and copulate, 2. males allowed only to court, i.e. deprived of copulation, and 3. males deprived of both courtship and copulation. In order to prevent mating in the courtship-only group, females were manipulated to prevent sperm transfer (see Treatment Study). Females were exchanged regularly to ensure that males had access to virgins and the opportunity to court and mate novel females. Virgin accessibility is crucial as females do not mate multiply (Becker *et al.* 2003, South and Arnqvist unpublished). This feature, monandry, is also convenient in order to measure the number of matings each male obtains.

### 2.2.1 Treatment study- method and efficacy of female manipulation

#### 2.2.1.1 Objectives

I conducted a study in order to procure an effective and reliable method of preventing sperm transfer. I chose to manipulate females and therefore attempted to find a method to block the female gonotreme, or vaginal opening. Female manipulation is preferred as physically altering males could potentially affect male mating behavior which would seriously impair the integrity of the main study. Male courtship behavior must be as close to natural as possible and the same across treatment groups in order to allow an accurate assessment of costs. Consequently, in

addition to the effectiveness of the treatment, I wished to determine whether males would court manipulated and unmanipulated females differentially. I also examined whether courtship intensity is affected by time. This observation of courtship rates over time was the basis for deciding the amount of time a male should have access to one group of females before introducing novel females. I also wished to determine whether the two female treatment groups would show differential mortality. Accordingly, I set out to test these three null hypotheses:

H<sub>0</sub>1. Female manipulation does not significantly affect male courtship

H<sub>0</sub>2. Time does not significantly affect male courtship

H<sub>0</sub>3. Time affects male courtship intensity of both manipulated and unmanipulated females in the same manner

### ***2.2.1.2 Female manipulation method***

Several methods of gonotreme obstruction were tested before selecting the method employed in the main study. Various types of glue were assessed, both toxic super-glues and a non-toxic water-based glue. However, mortality was extreme using the toxic glues and an initial experiment using the non-toxic glue failed when the majority of the treated females died within a week of manipulation. Prolonged exposure to CO<sub>2</sub> (used to sedate the females during manipulation) was also determined to decrease female lifespan considerably and therefore exposure was limited. Finally, I discovered a water-based white acrylic paint which obstructed the gonotreme without causing excessive mortality.

Virgin females at least three days old were placed individually in vials stopped with cotton. A CO<sub>2</sub> gun was used to introduce CO<sub>2</sub> to the vial. Females were exposed to the gas for approximately 10 seconds and once anaesthetized transferred onto a CO<sub>2</sub> seep plate placed under a dissecting scope. Females were mounted on a slide support in order to expose her posterior ventral region. Using paint on the tip of a pin, the genital bristles and the abdominal scales in the immediate surrounding were removed (Figure 5c). The genital bristles, employed in a superficial coupling phase of courtship, were removed to allow accurate placement of the paint over the genital pore. Scales mix with the paint decreasing its visibility; removal of scales adjacent to the genital hollow allows clean paint application and thus ability to later confirm paint adherence with the naked eye. Paint was applied to the genital hollow from the eighth sternal segment (site of removed genital bristles) to just ventrally anterior to the post genital lobe- effort was made to secure the post genital lobe to the paint to create a “lid” over the gonotreme (Figure 5d) The manipulated female was replaced in the vial ventral side up and the vial was stopped with cotton. As the female recovered, she was monitored to be sure that the abdomen did not stick to the vial. On the few occasions an abdomen became fixed to the vial,

gentle tapping or rolling the vial generally freed the female. Manipulated females were returned to the main holding terrarium only when they had returned to an upright resting position and after at least five minutes after removal from the CO<sub>2</sub>. Manipulated females were included in the experiment at least four days from time of treatment.

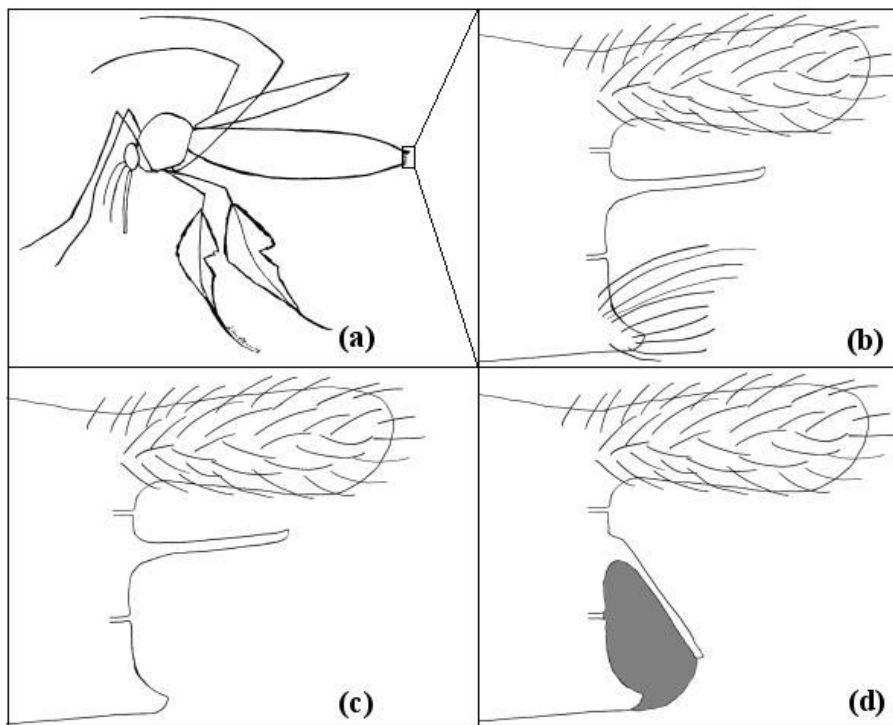

Figure 5. Steps of the gonotreme obstruction method with the manipulated genital region in detail. (a) female *S. cyaneus* mosquito with genital region boxed; (b) pre-manipulation; (c) post-removal of genital bristles and abdominal scales; (d) acrylic paint obstructing the gonotreme and creating a “lid” with the post genital lobe.

### 2.2.1.3 Experimental design

I observed male courtship of manipulated and unmanipulated females. I prepared 12 terraria each of which housed 20 mosquitoes- 10 virgin males and 10 virgin females. Females in six of the terraria were manipulated following the method described above and in the other terraria six females were untreated. Each terrarium was then observed for 1.5 hours per day for 14 days, allowing for a comparison of courtship between the two groups. Observations were performed between 10:00 and 14:00, the peak light hours of the photoperiodic regime. Courtship behaviors were recorded using standard notation according to Hancock *et al.* (1990a, see Appendix ## for a description of courtship behaviors). Male and female mortality was noted each day.

To determine the reliability of the female sperm obstruction method, manipulated females were given provisions to lay eggs. If manipulated females laid eggs they were considered mated and the method ineffective. However, if manipulated females, given adequate provisions and time, did not lay eggs, and the paint was seen to be still intact, the manipulation would be considered effective. At the conclusion of the observation period manipulated females were offered a blood meal each day for 5 days by inserting the author's hand into the terrarium. Females which did not blood feed after five blood offerings were considered unmated and euthanized. Blood fed females were housed individually and provided with an egg cup. Egg cups were checked for eggs after one week. If no eggs were present, the female was offered blood each day until she accepted or up to 5 days. After a second week, the egg cups were checked again for the presence of eggs and females were then euthanized. All manipulated females (n=60) were inspected under the dissecting scope to ascertain if the paint seal was intact.

#### **2.2.1.4 Data analysis**

In order to test the three null hypotheses (see above), I measured courtship intensity using three different courtship attributes: number of male alignments with a female, number of male alignments to either a male or female (total alignments), and total courtship duration. The data was analyzed using a repeated measures analysis for which each terrarium is considered a replicate, or a subject. The female manipulation status is a between-subject factor, whereas time is a within-subject factor.

To test for significant differences in mortality between manipulated and unmanipulated female groups, I first fit the linear function  $y = 10 + \beta * \text{time}$  to the number of females surviving over time in each terrarium. I then tested for significant differences in slope between the two female groups using the Mann-Whitney-Wilcoxon test.

#### **2.2.1.5 Results**

No manipulated females laid eggs and all females still had the paint 'lid' at the conclusion of the treatment study. There was no significant difference in male courtship between the groups for all three courtship intensity measurements. Time (i.e., observation or day) did affect the number of male alignments but this effect did not depend on treatment (see Table 1). A visualization of the data shows that time had a negative effect on the number of alignments (Figure 6) and that courtship tended to decrease over time (Figure 7). There was not a significant difference in the linear regression function slopes between the manipulated and

unmanipulated female groups (i.e., no significant mortality difference; Mann-Whitney  $U = 16.0$ ,  $p = 0.74$ ).

Courtship Intensity Measure	Factor	F	$p$
Alignments with females	Treatment	1.707 <sub>1,10</sub>	0.221
	Day	4.994 <sub>13,130</sub>	0.000*
	Interaction	0.900 <sub>13,130</sub>	0.555
Total alignments (with both males and females)	Treatment	1.452 <sub>1,10</sub>	0.256
	Day	7.030 <sub>13,130</sub>	0.000*
	Interaction	0.686 <sub>13,130</sub>	0.774
Total courtship duration	Treatment	0.247 <sub>1,10</sub>	0.630
	Day	0.565 <sub>13,130</sub>	0.878
	Interaction	0.017 <sub>13,130</sub>	1.000

Table 1. Repeated measures analysis of variance results. Degrees of freedom follow F-value (factor,error) and \* denotes significant values.

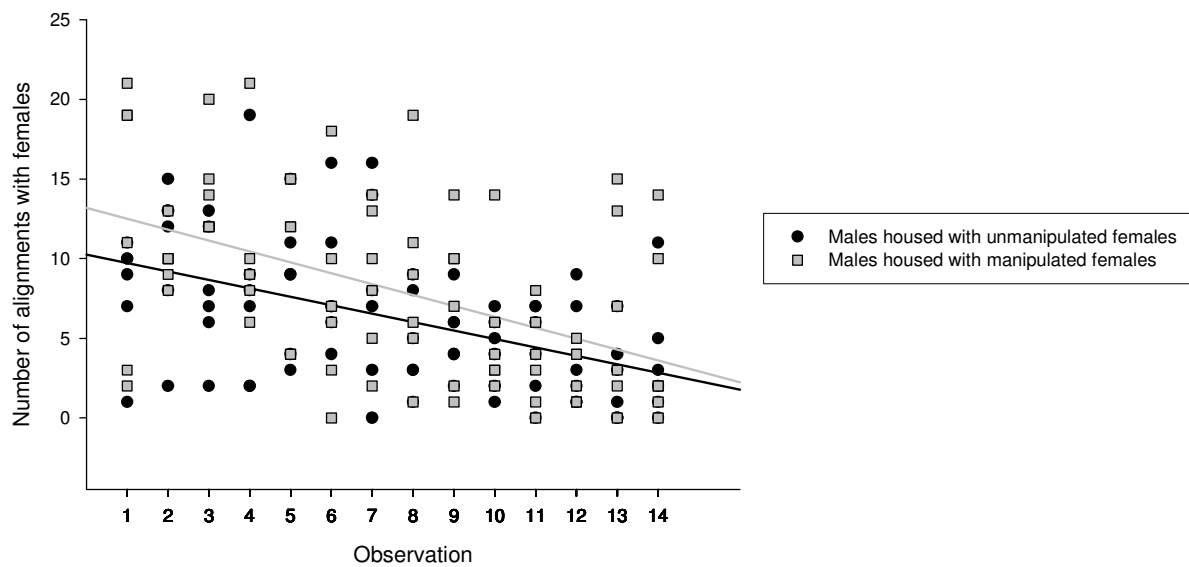

Figure 6. Number of male alignments with females over time. The lines in the figure are trendlines to clarify the relationship of alignments and time.

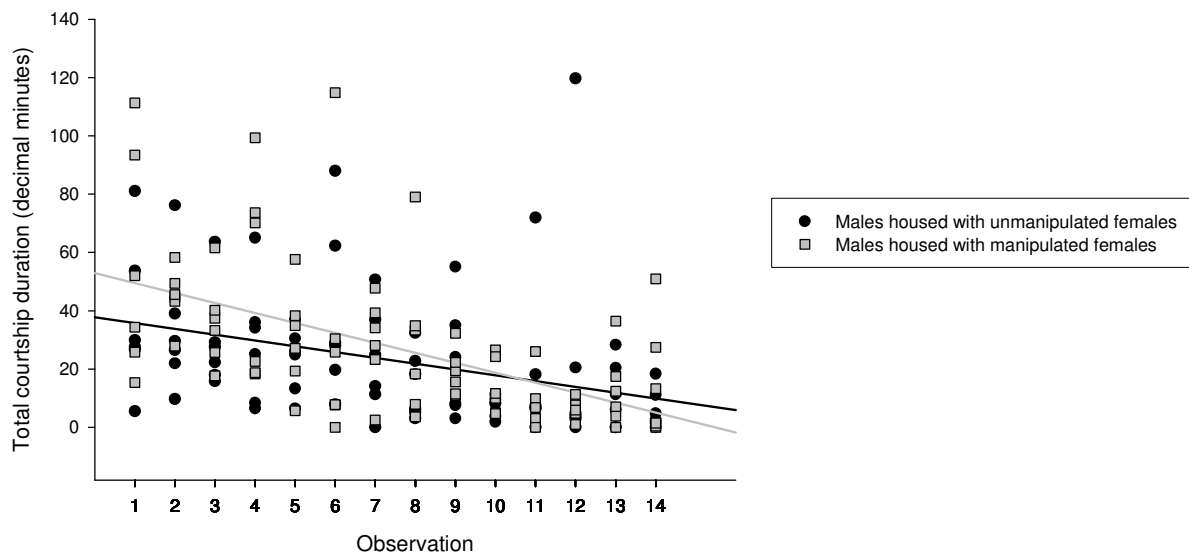

Figure 7. Total courtship duration (in decimal minutes) over time. The lines in the figure are trendlines to clarify the relationship of alignments and time.

### 2.2.1.6 Conclusions

The female manipulation method is efficient and reliable. Manipulated females were not fertilized, the groups exhibited comparable mortality and males courted females in the groups equally. Due to the decline in courtship over time females in the main study will be exchanged after one week, to provide males with frequent access to novel virgin females.

### 2.2.2 Main study methods

As stated previously, I examined the male costs of reproduction by comparing mortality across treatment groups. Table 2 outlines the treatment groups and the costs males experience. It should be noted that housing multiple males to control for density would not allow for an accurate control for courtship costs, because males court males as well as females.

Treatment	Housing arrangement	Cost incurred
Individual Male	alone	none
Courtship Only	with four manipulated females	courtship
Courtship + Copulation	with four unmanipulated females	courtship and copulation

Table 2. The treatment groups and the reproductive costs males experience.

Before inclusion in the experiment, virgin males were housed individually and virgin manipulated and unmanipulated females were housed in terraria at a density of 20-30 individuals. Females were manipulated at least three days after emergence and entered into the

experiment at least four days after the time of treatment. Individual males were entered into the experiment one week after emergence over a period of 8 weeks as adequate numbers of virgins became available. For every cohort, an effort was made to assign an equal number of individuals to each of the three treatment groups in order to control for any differences between the cohorts. The final sample size for each treatment was: Individual Male,  $n = 24$ ; Courtship Only,  $n = 22$ ; Courtship + Copulation,  $n = 19$ .

Males were housed with four females of various ages (from 4 days to several weeks old) and provided with novel females each week. Courtship behavior was observed for one hour twice weekly. Mortality checks were performed daily. Dead females were noted and replaced immediately by a novel female. Early in the experiment, two males were killed by entanglement in the terrarium netting and were replaced by new males.

After one week with a male, the females were removed and replaced by novel females. Unmanipulated females were removed to partitioned terraria (same dimensions as the other terraria [Figure 4] but with a wire mesh divider across the width at the center of the tank to separate it into two smaller containment areas, each side having an opening and food and water vials). Females from the same male and week were housed together and given an identification associated to the male. These females were offered blood twice a week for two weeks or until bloodfed (mated females generally feed within 2 weeks of mating, Sandra South, unpublished data). After an initial bloodmeal females were removed to individual partitioned terraria and provided with an egg cup and individual id number. The egg cup was checked after one week. If no eggs were present, the female was offered a second bloodmeal and provided with a fresh egg cup. After the second week, the egg cup was checked a final time for eggs. After removal from males, manipulated females were reused in the experiment with other males.

### ***2.2.3 Statistical and Graphics Software***

For both the treatment and main study, Systat 11 was used to perform all analyses and SigmaPlot 8.0 to visualize results.

## **3. RESULTS**

### **3.1 Male Mating Rates**

One of the objectives was to determine whether males, like females, are monogamous or whether they mate multiply. Number of matings was determined here by the number of unmanipulated females who laid eggs after removal from the male- I note that this measurement is a conservative estimate as not all mated females may have blood fed. I found



that males mated multiply. Lifetime number of successful copulations varied from zero to seven (mean =  $3.053 \pm 2.158$ ). Males of this treatment lived an average of 52 days with a mean copulation rate of 0.06 copulations per day. Even the most successful male evidently inseminated less than 30% of the females he was housed with. The longest living male inseminated 14% of the females and for two males I did not find evidence of a single copulation. Although the number of matings per male increased with their lifespan (Pearson's correlation:  $r=0.543$ ,  $n=19$ ,  $p=0.016$ , Figure 8), the majority of copulations occurred in the first few weeks of their life: 55% of all matings occurred within the first two weeks of exposure to females and 33% were achieved during the first week. One male deviated from this pattern obtaining seven copulations even though his lifespan was shorter than average. Four of these seven copulations were obtained in the first week.

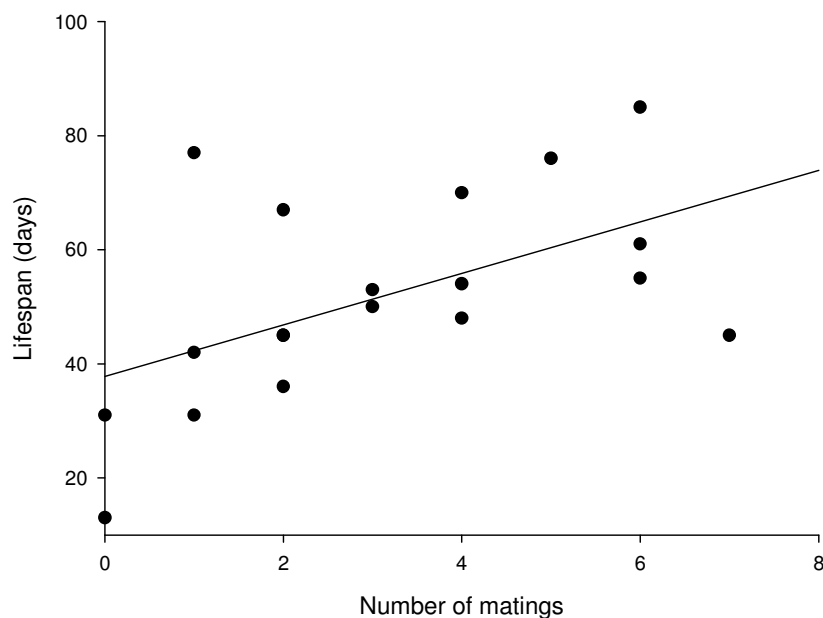

Figure 8. In the Courtship + Copulation treatment group, males who lived longer mated more. Each data point represents an individual ( $n=19$ ).

### 3.2 Courtship Behavior

Although the treatment study found no differences in courtship behavior between the treatment groups, I wanted to confirm this for the main study. I used four measurements of courtship behavior: lifetime total courtship duration, lifetime total alignments with a female, copulation attempts, and lifetime total number of female rejection 'kicks' (see Appendix for descriptions of courtship behavior). Each value was divided by the number of times the male was observed

in order to control for differences in lifespan. Courtship intensity (duration, alignments, and copulation attempts) did not differ between the treatments however, manipulated females performed rejection kicks significantly more often (Table 3, Figure 9)

Courtship Behavior Measurement	t	d.f.	p
Courtship duration	0.195	39	0.846
Number of alignments	-1.484	39	0.146
Number of copulation attempts	-0.209	28.8*	0.836
Number of female kicking events	-2.587	33.6*	0.014

Table 3. t-tests comparing courtship behavior measurements between the treatments show there is no difference in courtship intensity measurements, however, they do differ in lifetime female rejection kicking events. Each measurement value was divided by the number of observations per male in order to control for lifespan differences. \* denotes application of separate variance t-test due to unequal treatment variances

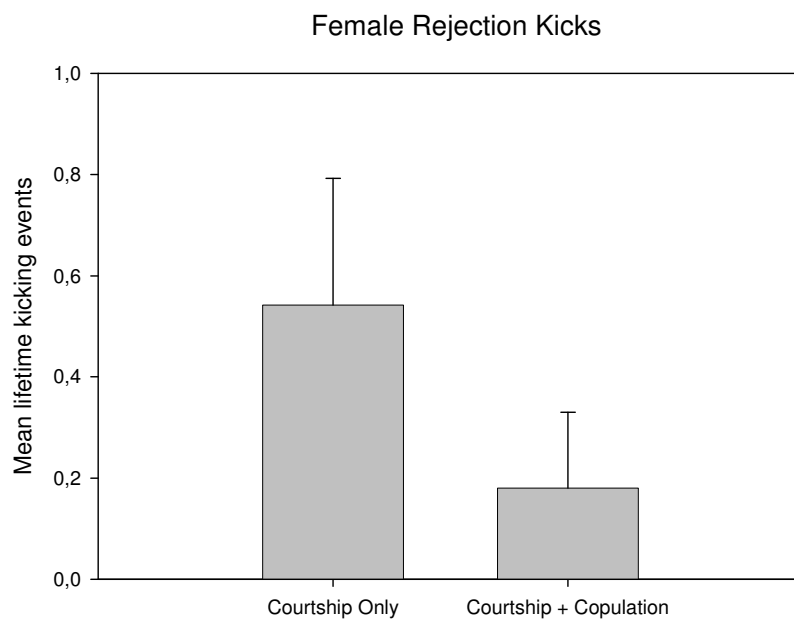

Figure 9. Males who could copulate were kicked significantly less than males who could only court. Error bars denote the upper half of the 95% confidence interval.

The four courtship behaviors investigated are strongly correlated (Table 4). In order to avoid confounding results in the following analyses, courtship duration is used as the sole courtship intensity measurement unless otherwise noted.

Courtship behavior measurement	Courtship duration	Copulation attempts	Alignments	Female kicking events
Courtship duration	1.000			
Copulation attempts	0.695	1.000		
Alignments	0.630	0.700	1.000	
Female kicking events	0.621	0.627	0.642	1.000

Table 4. Pearson correlation matrix of the courtship behavior measurements. Each total behavior value was divided by the number of observations in order to control for lifespan differences.

When males were courting, they spent an average of 24% of each observation hour (mean = 14 ± 17 minutes) engaged in courtship (mean calculated from all non-zero courtship values). However, actual courtship duration varied considerably. 39% of males invested an average of more than 30% of each observation hour to courtship and several males spent over 90% of at least one observation period courting. As recorded courtship behavior started with male alignment to a female, these courtship duration values do not include time males spent patrolling perches or attempting to align with females.

### 3.3 Male Longevity

There was not a significant difference in lifespan among the three treatment groups (ANOVA:  $F_{2,62}=1.870$ ,  $p=0.163$ , Figure 10). However, graphing the mean lifespans shows a conspicuous difference between the treatment group extremes: males housed individually and those who could both court and copulate (Figure 10). The difference in means between these treatment groups is only borderline non-significant and would become significant using a one-tail p-value (pooled-variance two-tailed t-test:  $t=1.889$ , d.f. 41,  $p=0.066$ ).



Figure 10. There was not a significant difference in male lifespan among the three treatments during this study. Error bars denote the upper half of the 95% confidence interval.

### 3.4 Courtship Effort Over Time and its Affect on Male Lifespan

Courtship intensity decreased over time (the mean slope value obtained from linear regression analyses performed for each male is significantly negative:  $t=-3.849$ ,  $d.f.=40$ ,  $p<0.001$ , Figure 11). The negative relationship between courtship intensity and time did not differ between treatments (analysis of regression parameters using a MANOVA: Wilks'  $\lambda=0.979$ , Rao's  $F_{2,38}=0.406$ ,  $p=0.669$ , Figure 11).

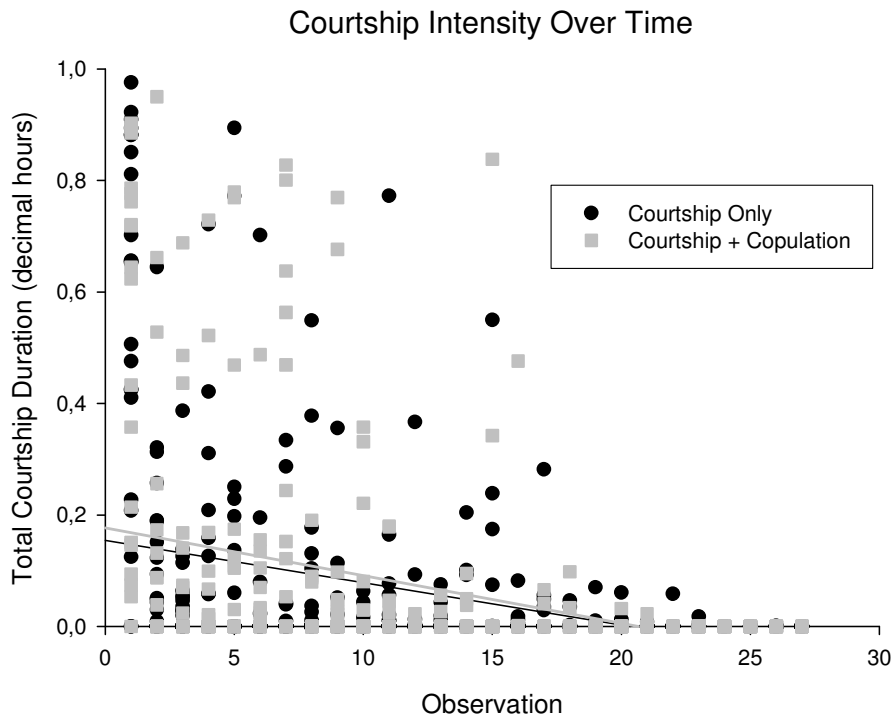

Figure 11. Courtship decreased over time. This figure is only to illustrate the trend in the data; courtship here is measured as total duration whereas the values for the regressions were controlled for differences in lifespan. The lines in this figure merely clarify the negative trend, they are not true regression lines.

Overall, males who courted more intensely lived significantly shorter (ANCOVA:  $F_{1,37}=11.239$ ,  $p=0.002$ , Figure 12) and this affect was stronger in the Courtship Only treatment (ANCOVA interaction term:  $F_{1,37}=8.624$ ,  $p=0.006$ , Figure 12). In fact, further analysis shows that the significant effect is found exclusively in the Courtship Only treatment: the negative relationship of courtship intensity and lifespan is not significant in the Courtship + Copulation treatment group (Pearson correlation:  $r=-0.042$ ,  $N=18$ ,  $p=0.846$ ). Although the treatment factor is significant when courtship duration is held constant ( $F_{1,37}=11.380$ ,  $p=0.002$ ), inclusion of the interaction term in ANCOVA denotes that the treatment effect actually refers to a difference in the intercepts, which in this case holds no biological significance.

The previous findings are the result of modeling using only one courtship behavior measurement (courtship duration). When all four behaviors and their interactions are included in the model, courtship duration is nearly significant and treatment is still significant, however, none of the other behaviors nor any of the interaction terms significantly affect lifespan (Table 5). Again, the inclusion of the interaction terms means that the treatment affect represents a significant difference in intercepts.

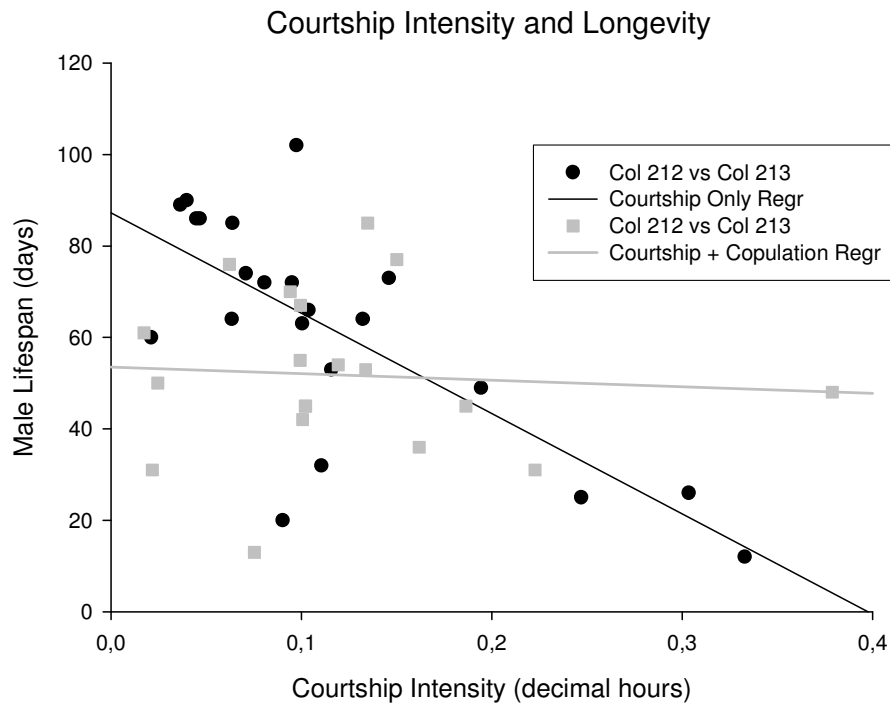

Figure 12. Male courtship intensity and longevity have a negative relationship; the affect is statistically significant only in the Courtship Only treatment. The lines in this figure merely clarify the negative trend, they are not true regression lines.

Source	F	$p$
Treatment	12.673 <sub>1,31</sub>	0.001
Courtship duration	3.840 <sub>1,31</sub>	0.059
Alignments	2.093 <sub>1,31</sub>	0.158
Copulation attempts	1.373 <sub>1,31</sub>	0.250
Female rejection kicking events	0.136 <sub>1,31</sub>	0.715
Treatment x Courtship duration	2.460 <sub>1,31</sub>	0.127
Treatment x Alignments	0.301 <sub>1,31</sub>	0.587
Treatment x Copulation attempts	0.023 <sub>1,31</sub>	0.881
Treatment x Kicking events	0.148 <sub>1,31</sub>	0.703

Table 5. ANCOVA results using a model including treatment, all four observed courtship behaviors as covariates, and lifespan as the dependent variable.

In an effort to provide a clearer representation of the data and to remove error and uncertainty in the model due to the high correlation between courtship behaviors (Table 4), I performed a Principal Component Analysis. Factor analysis of the four behavioral variables resulted in one component (PC1) with a substantial eigenvalue which explains nearly 74% of

the variance in the data matrix. The next three principal components had low eigenvalues and explained little of the variance (Table 6). Similar component loadings (covariance of the original variable to the derived principal component) among the courtship variables on PC1 provides further evidence of courtship measurement multicollinearity (Table 7). I therefore decided to use PC1 as a proxy for the courtship behaviors.

	PC1	PC2	PC3	PC4
Eigenvalue	2.958	0.399	0.366	0.277
Variance explained	73.960	9.979	9.147	6.914

Table 6. Results of courtship behavior Principal Component Analysis.

Courtship Behavior Component Loading	PC1
Courtship duration	0.856
Alignments	0.865
Copulation attempts	0.881
Female rejection kicking events	0.837

Table 7. Component loading of Principal Component One

PC1 was significantly related to lifespan (ANCOVA:  $F=16.095_{1,38}$ ,  $p<0.001$ ; Figure 13). The interaction term was not significant (ANCOVA:  $F=3.600_{1,37}$ ,  $p=0.066$ ) and was therefore removed from the model. Without the interaction term, the treatment factor value no longer represents intercept difference but corresponds to a treatment affect. The removal of courtship behavior variance revealed a significant affect of treatment on longevity with a 14 day disparity in least squares mean lifespan (ANCOVA:  $F=5.705_{1,38}$ ,  $p=0.022$ ; Figure 13).

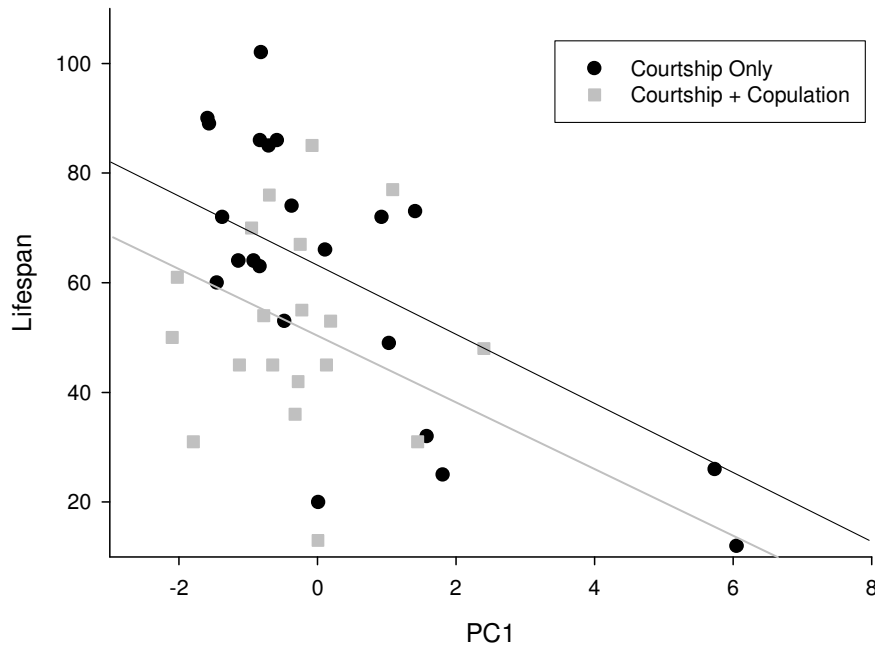

Figure 13. PC1 and male lifespan have a significantly negative relationship. Although the treatment groups are affected by PC1 in the same manner, the means are significantly different.

#### 4. DISCUSSION

This study revealed four important findings: (i) *S. cyaneus* males mate multiply, (ii) courtship activity appears to decrease male longevity, (iii) male success is positively related to lifespan and (iv) copulations *per se* are costly for males. Although males did mate multiply, the rates are low in comparison with that found in other dipteran laboratory and natural populations, where males may inseminate several to many females in a single day (Cordts and Partridge 1996, Bonduriansky and Brassil 2002, Pomiankowski *et al.* 2005). In another mosquito, *Aedes aegypti* (Anophelinae: Aedes), males will mate repeatedly without rest, even after sperm depletion (Gillett 1971). The *S. cyaneus* males, on the other hand, obtained only an average of three matings during their lifetime (mean lifespan was 52 days). Perhaps the low male mating rate is related to the elaborate ornaments and diverged mating system this tribe exhibits which are absent in other mosquitoes which mate at a higher rate.

It is unknown whether the male mating rate observed here for *S. cyaneus* is similar to that found in nature. The low rate could either be due to inadequate lab/experimental conditions or a range of natural causes inherent to the mating system. If males exhibit strong choice for superior females, it may be that I did not provide an adequate number of females for males to choose between. Alternatively, the males who did not succeed in mating were of poor quality



or condition. Härdling *et al* (2008) suggests that one cause for variation in number of matings obtained by males could be differences in sperm/ejaculate recovery time.

The low mating rate and positive correlation with lifespan indicates that copulation success could be condition-dependent. In general, males allowed to copulate had a shorter lifespan than males who were disallowed to copulate, showing that there are costs associated with copulation. However, the positive relationship between lifespan and number of matings among males allowed copulations suggests that males in better condition or of higher genetic quality may suffer fewer costs and therefore live longer and mate more. Males in greater condition would then be able to copulate more and at a lower cost than their poor-condition conspecific.

It is also possible that I was unable to observe a statistically significant cost of copulation due to the very low mating rate. Cordts and Partridge (1996) found that in the dipteran *Drosophila melanogaster*, courtship alone significantly decreased male lifespan but they found no evidence of a copulation cost. The authors suspected that perhaps the cost of successful copulation was undetected due to low mating rates: 0.25 copulations per day, which was still four times greater than the rate of 0.06 observed in this study. The authors refrain from concluding trivial mating costs due to the inability to truly separate the costs of courtship and mating; this attribute is of course one I must consider when drawing conclusions. In this case, it is clear that copulation had a general negative effect on lifespan, but the mating rate was apparently too low to see a direct significant cost per copulation. The cost of mating became apparent only after controlling for courtship intensity.

The propensity to mate multiply is important in gauging the opportunity for male mate choice. If males are only able to obtain a single or few copulations, they should be extremely particular about where to allocate their limited energy and/or sperm. In contrast, if males are able to mate repeatedly without cost, they should not be particular as to whom they inseminate. However, even if males are capable of mating multiply, if each mating is costly and reduces the future opportunities for copulation the male should optimize ejaculate allocation and choose the best partner possible.

PC1, which captures most of the variance of all four courtship behaviors, has a significantly negative relationship with lifespan. The affect of PC1 on lifespan did not differ significantly between the treatments, although the treatment lifespan means were different. Overall, males who courted more intensely did not live as long as males who courted with less vigor. Interestingly, although courtship duration alone had a negative affect on lifespan, its affect was significant only for males who could not copulate. This result suggests that either there is a difference in courtship behavior between the treatments or that courtship without

copulation poses a greater physiological burden than courtship with copulation. The only statistically different behavior I observed was in the amount of female rejection kicks individuals endured. It is plausible that the inability to achieve superficial coupling and eventually copulation caused non-copulating males to alter their courtship behavior in some aspect I did not record, finally inducing the females to reject them. Males could potentially differ in the rate of leg waving or body dipping and an increase or decrease in the rate of courtship behavior may stimulate the females to reject potential mates. Cordts and Partridge (1996) surmised that non-copulating *D. melanogaster* males suffered decreased lifespans due to some physiological affect of exposure to females. The authors did not suggest a process which could reduce lifespan, but I can speculate, merely for illustrative purposes, that perhaps persistent courtship without copulation increases hormones to damaging levels, whereas males who copulate experience physiological processes which lower hormones to innocuous or at least less-harmful levels.

A key question is whether the difference in lifespan I observed is biologically significant. Although this is unclear, it is quite plausible. The nearly statistically significant 23% shorter lifespan of males who engage in complete sexual behavior as compared to males who abstain from any sexual activity may be substantial. Especially when one considers the amount of time males spend courting and that it is likely that the lifespan in natural conditions, with predation and fluctuating temperatures, is much shorter (Gillet 1971). Although lifespan is species specific, and estimates are largely theoretical, female mosquitoes are generally thought to live two to three weeks or up to several months in the field and males to have a much shorter lifespan (Rey 2006). If the *S. cyaneus* male has a shorter natural lifespan, the mortality increase I observed could certainly be biologically significant. Unfortunately, models of male mate choice do not seem to include a quantitative element. Empirical studies which investigate mate choice report statistically significant costs, however, models of male preference do not assign a cost threshold for biological significance. Furthermore, in the field, the male may suffer from other mating costs I did not simulate which may interact with energy costs, compounding the actual cost of reproduction

Time lost during courtship may be a particularly important cost for this system. The mean time males spent actually courting during observation periods was considerable and could be a substantial cost. Time males invest in courtship is time that could otherwise be allocated to searching for food and other mates as well as time lost for courting and mating other partners once they are found. Prolonged courtship not only bears energetic and lost time costs, but can increase the risk of predation (Champion de Crespigny and Hosken 2007).

Increased predation risk due to conspicuous ornaments and/or prolonged courtship can also constrain male mate choice. Woods *et al.* (2007) found evidence of such a situation in a beetle. The male lantern firefly flashes a brilliant light to attract mates and then proceeds with a lengthy courtship lightshow once he encounters a potential partner. Surprisingly, the sexual signal itself is relatively cheap; it takes more energy to walk than to produce the baseline signal. However, the predation risk of a signaling male is significant and the risk increases dramatically when males signal more intensely which females, as well as the predator, find more alluring. The *S. cyaneus* males may face increased predation risk as they patrol perches searching for potential mates. The prolonged courtship which includes conspicuous paddle waving may also increase predation risk- this would likely negatively affect females as well as they are in direct contact with the male.

Although males suffered increased mortality due to courtship and copulation, they nevertheless mated repeatedly. As discussed earlier, mating could be condition dependent so that males who are in better condition are able to both mate more and live longer. It could also be that although males show a preference for high-quality females, in the right conditions they do not forego the opportunity to mate with receptive females. Reading and Backwell (2007) found that although the male fiddler crab (*Uca mjoebergi*) prefers larger females, they did not reject mating opportunities with small females. The authors contend that the highly male-biased OSR induces males to mate when the opportunity avails as the receptive mate encounter rate is low. A similar situation is plausible for *S. cyaneus*. Even though matings may be costly, if potential mates are limited it may not benefit a male to reject lesser quality females. Thus it is possible males show a preference for certain females, however, they do not completely forego substandard mating opportunities.

On the other hand, because males undertake the mate searching and are apparently more active than females in general in *S. cyaneus* (Hancock *et al.* 1990a) it is possible that males suffer a higher risk of predation. Further, male lifespan may be restricted by the fact that they take no blood meals. If this is true, a female-biased OSR may promote male mate choice, since male mating opportunities may not be as restricted. In summary, the strength of male mate choice may depend on local densities, OSR and rate of encountering receptive mates (Reading and Backwell 2007). *S. cyaneus* males may preferentially court and mate higher-quality females, but it is possible that they optimize their reproductive output by courting inferior females. Males may, however, invest less energy or resources in mating events with lower-quality females (Reading and Backwell 2007).

In this study, *S. cyaneus* males suffered higher mortality due to reproduction. It is possible that the reproductive costs they incur from courtship and copulation generate a

situation in which males would benefit from preferring high-quality partners. However, the results are by no means conclusive. Further investigation is necessary to make more definitive inferences about male mate choice and the function of the sexually monomorphic ornament of this species. A mate choice experiment could provide decisive evidence for male preference. If males preferentially court and mate females with certain paddle characteristics, it would be difficult to deny sexual selection as an evolutionary cause for female ornamentation. Indeed, a mate choice experiment is underway and may offer valuable insight into the maintenance of these extravagant ornaments shared by both males and females (South, pers. comm.). If males are not found to prefer females with some differential paddle attribute, more extensive behavioral observations should be undertaken to determine whether the paddle could serve some social or male-mimicking function. It is unlikely that an intersexual genetic correlation is the sole cause of the female ornament, but this alternative should not be discounted.

#### ACKNOWLEDGEMENTS

I can't express enough my gratitude for the patience, guidance, and respect both Göran and Sandra showed me throughout every stage of my thesis work. I greatly appreciate Göran's willingness to devote hours teaching and guiding me through difficult concepts and statistical analysis. Sandra was an incredible investigative partner. Her knack for gently pushing me towards the goal and her investment of endless hours helping and directing me did not go unnoticed; her patience is remarkable. Also, I am still in awe over Sandra's accurate and meticulous editing; this paper is only what it is because of her assistance. I am extremely grateful for the learning experience Göran and Sandra have allowed me. I am forever indebted- thank you.

Thank you to my friends who helped to maintain my sanity and spirits throughout this entire educational experience and particularly the months of intense lab work, especially Martin, Maria, and Santi. Thank you to my family for love and support and also for pushing me to challenge myself.

## APPENDIX

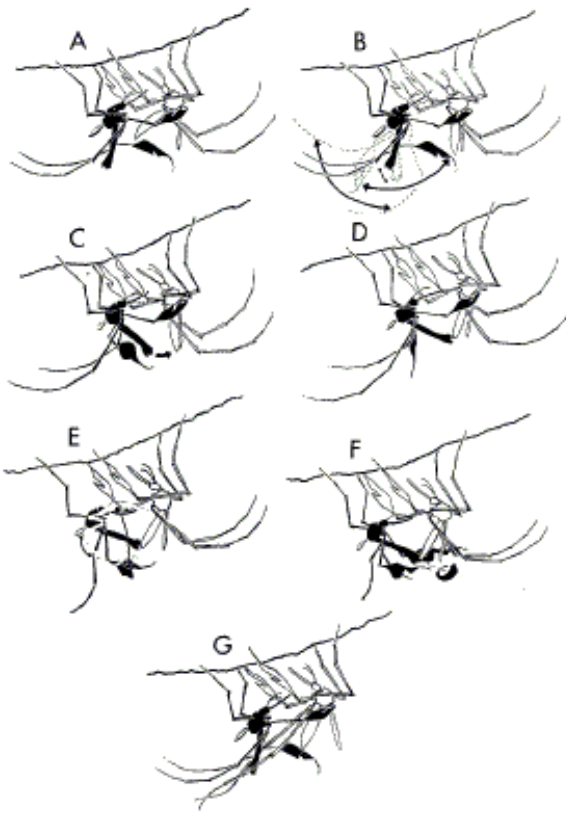

Figure A1. *S. cyaneus* seven stages of courtship. In this figure the male is on the left and shaded black. A) Initial male alignment with female and subsequent male free-leg waving: the male clasps the female's wing with one paddled midleg while waving the other arrhythmically and perpendicular to the female's body; B) male swing and lowering of female abdomen; C) male copulation attempt: often with the male clasping and pulling the female's adjacent hindleg with his free midleg; D) superficial genital coupling with the male still clasping the female's wing: the male's distal genital region of the gonostyli (Appendix Figure 2A) fasten to the female dorsal genital region leaving a narrow gap between the genitals (Appendix Figure 2B); E) male wave: release of female's wing and male synchronous up-and-down waving of the mid- and hindlegs; F) male waggle, after genital shift: male gonostyli folds against gonocoxites to allow full genital contact (Appendix Figure 2C); G) female pushing male with hindlegs (female rejection kicking). This notation was used in my investigations to standardize courtship behavior observations (figure from and figure text adapted from Hancock *et al.* (1990a))

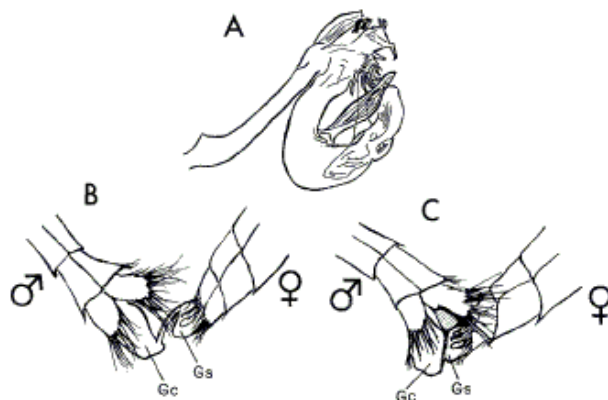

Figure A2. Semidiagrammatic lateral view of *S. cyaneus* genitalia. A) One male gonostylus, showing the slender proximal portion on the left and elaborate distal portion on the right. B) Superficial coupling, showing paired male gonostyli (Gs) attached to female but extended away from their respective gonocoxites (Gc), creating a gap between male and female genitalia. C) Full copulation (after genital shift), showing gonostyli folded against gonocoxites and adpression of male genitalia to female (from Hancock *et al.* (1990a))

## REFERENCES

- Aluja, M. and Norrbom, A. (2000). *Fruit flies (tephritidae): phylogeny and evolution of behavior*. CRC Press LLC
- Amundsen, T. (2000). Female Ornaments: Genetically Correlated or Sexually Selected? In Espmark, Y. Amundsen, T. and Rosenqvist, G. (Eds). *Animal Signals: Signalling and Signal Design in Animal Communication*. Tapir Academic Press: Trondheim, Norway. pp 133-154
- Andersson, M. (1994) *Sexual Selection*. Princeton University Press: Princeton, New Jersey.
- Andersson, S. (1994) Costs of sexual advertising in the lekking Jackson's widowbird. *The Condor* 96(1): 1-10
- Arnqvist, G. (2006) Sensory exploitation and sexual conflict. *Philosophical Transactions of the Royal Society B* 361:375-386
- Arnqvist, G. and Rowe, L. (2005) *Sexual Conflict*. Princeton University Press: Oxford.
- Bateman, A. J. 1948. Intra-sexual selection in *Drosophila*. *Heredity* 2: 349-368
- Becker, N., Petrić, D., Zgomba, M., Boase, C., Dahl, C., Lane, J., and Kaiser, A. (2003) *Mosquitoes and Their Control*. Kluwer Academic/Plenum Publishers. New York.
- Belton, P. (1974). An analysis of direction finding in male mosquitoes. In Barton Browne, L. (ed.), *Experimental Analysis of Insect Behaviour*, Springer-Verlag: New York. pp. 139-148
- Berglund A, Widemo MS, Rosenqvist G. (2005). Sex-role reversal revisited: choosy females and ornamented, competitive males in a pipefish *Behavioral Ecology* 2005 **16**:649-655
- Bisazza, A., Marconato, A., and Marin, G. (1989). Male mate preferences in the mosquitofish *Gambusia holbrooki*. *Ethology* 83: 335-343.
- Birkhead, T.R and Møller, A.P. (1998) *Sperm Competition and Sexual Selection*. Academic Press: New York.
- Bonduriansky, R. (2001) The evolution of male mate choice in insects: a synthesis of ideas and evidence. *Biological reviews of the Cambridge Philosophical Society* 76(3):305-339
- Bonduriansky, R., and Brassil, C. (2002) Senescence: rapid and costly ageing in wild male flies. *Nature* 420:377
- Burley, N. (1981) The evolution of sexual indistinguishability. In: Alexander, R. and Tinkle, D. (eds), *Natural Selection and Social Behaviour: Recent Research and New Theory*. Chiron Press: New York. pp. 121-137
- Champion de Crespigny, F. and Hosken, D. (2007) Sexual selection: signals to die for. *Current Biology* 17(19):R853-855
- Cordts, R., Partridge L. (1996) Courtship reduces longevity of male *Drosophila melanogaster*. *Animal Behaviour* 52: 269-278
- Daly, M. (1978) The cost of mating. *The American Naturalist* 112:771-774
- Darwin, C. (1859) *On the Origin of Species by Means of Natural Selection*. John Murray: London.
- Darwin, C. (1871) *The Descent of Man and Selection in Relation to Sex*. John Murray: London.
- David, P., Bjorksten, T., Fowler, K., and Pomiankowski, A. (2000) Condition-dependent signalling of genetic variation in stalk-eyed flies. *Nature* 406:186-188
- Dewsbury, D. (1982) Ejaculate cost and mate choice. *American Naturalist* 119: 601-610
- Duckworth, R. Medonca, M., and Hill, G. (2004) Condition-dependent sexual traits and social dominance in the house finch. *Behavioral Ecology* 15(5): 779-784
- Emlen, D. (2001) Costs and the diversification of exaggerated animal structures. *Science* 291:1534-1536
- Emlen D. and Oring, L. (1977) Ecology, sexual selection, and the evolution of mating systems. *Science* 197(4300): 215-223
- Engqvist L. and Sauer K.P. (2002) A life-history perspective on strategic mating effort in male scorpionflies. *Behavioral Ecology* 13(5): 632-636

- Fitzpatrick, S., Berglund, A., Rosenqvist, G. (1995) Ornaments or offspring: costs to reproductive success restrict sexual selection processes. *Biological Journal of the Linnean Society* 55(3):251-260
- Funk, D., and Tallamy, D. (2000) Courtship role reversal and deceptive signals in the long-tailed dance fly, *Rhamphomyia longicauda*. *Animal Behavior*, 59, 411-421
- Gillet, J. (1971) *Mosquitoes*. Chaucer Press: Suffolk
- Galan, P. (2000) Females that imitate males: dorsal coloration varies with reproductive stage in female *Podraxis bocagei* (Lacertidae). *Copeia* 819-825
- Gwynne, D., Bussière, L., and Ivy, T. (2007) Female ornaments hinder escape from spider webs in a role-reversed swarming dance fly. *Animal Behaviour* 73:1077-1082
- Halliday T. (1983) The study of mate choice. In Bateson, P. (ed) *Mate Choice*. Cambridge University Press: Cambridge.
- Hancock, R., Foster, W., Yee, W. (1990a) Courtship behavior of the mosquito *Sabethes cyaneus* (Diptera: Culicidae). *Journal of Insect Behavior* 3(3): 401-416
- Hancock, R., Yee, W., Foster, W. (1990b) Tests of *Sabethes cyaneus* leg paddle function in mating and flight. *American Journal of the American Mosquito Control Association* 6:733-735
- Hankison S., and Ptacek, M. (2007) Within and between species variation in male mating behaviors in the Mexican sailfin mollies *Poecilia velifera* and *P. petenensis*. *Ethology*, 113, 802–812
- Harbach and Petersen (1992)
- Harbach, R. and Peyton E. (1990) Transfer of the subgenus *Davismyia* from *Wyeomyia* to *Sabethes* and description of the type species, *Miamyia Petrocchia* (Diptera: Culicidae). *Mosquito Systematics* 22(3): 149-159
- Härdling, R., Godsen, T., and Aguilée, R. (2008) Male mating constraints affect mutual mate choice: prudent male courting and sperm limited females. *The American Naturalist* (in press).
- Johnstone, R. (1993) The evolution of animal signals. In Krebs, J. and Davies, N. (eds.) *Behavioral Ecology: An Evolutionary Approach*. Blackwell Science: Oxford.
- Johnstone, R., and Grafen, A. (1993) Dishonesty and the handicap principle. *Animal Behaviour* 46:759-764
- Johnstone, R., Reynolds, J., and Deutsch, J. (1996) Mutual mate choice and sex differences in choosiness. *Evolution* 50(4):1382-1391
- Johnstone R., (1997) The tactics of mutual mate choice and competitive search. *Behavioural Ecology and Sociobiology* 40:51-59
- Jones, I., and Hunter, F. (1999) Experimental evidence for mutual inter- and intra-sexual selection favoring a Crested Auklet ornament. *Animal Behavior* 57:521–528.
- Jones, K., Monaghan, P., and Nager, R. (2001) Male mate choice and female fecundity in zebra finches. *Animal Behaviour* 62(6):1021-1026
- Kamler, J., Ballard, W. Lemons, P. and Mote, K. (2004). Variation in the mating system and group structure in two populations of swift foxes, *Vulpes velox*. *Animal Behaviour* 68:83-88
- Kawada, H., Tatsuta, H., Arikawa, K., Takagi, M. (2005): Comparative study on the relationship between photoperiodic host-seeking behavioral patterns and the eye parameters of mosquitoes. *J. Insect Physiol.* 52:67-75
- Kitchen, A, Gese, E., Waits, L., Karki, S. and Schauster, E. Multiple breeding strategies in the swift fox, *Vulpes velox*. *Animal Behaviour* 71:1029-1038
- Kokko H. and Johnstone R. (2002) Why is mutual mate choice not the norm? Operational sex ratios, sex roles and the evolution of sexually dimorphic signalling. *Philosophical Transactions of the Royal Society, London B* 357:319-330
- Kokko, H., and Monaghan, P. (2001) Predicting the direction of sexual selection. *Ecology Letters* 4:159-165

- Kraaijeveld K., Gregurke, J., Hall, C., Komdeur, J., and Mulder R. (2004). Mutual ornamentation, sexual selection, and social dominance in the black swan. *Behavioural Ecology* 15(3):380-389
- Kraaijeveld K., Kraaijeveld-Smit, F., and Komdeur, J. (2007) The evolution of mutual ornamentation. *Animal Behaviour* 74: 657-677
- Kraaijeveld K. and Reumer, B. *Animal Behaviour; new research*. In Weber, E. and Krause, L. (eds) Nova Publishers: Hauppauge NY (in press).
- Krebs and Dawkins, R. (1978) Animal signals: information or manipulation? In J. Krebs and N. Davies (eds) *Behavioural Ecology*, pp 282-309
- Land M., Gibson, G., Horwood, J. and Zeil, J. (1999) Fundamental differences in the optical structure of the eyes of nocturnal and diurnal mosquitoes. *Journal of Comparative Physiology* 185: 91-103
- Lande, R. (1980) Sexual dimorphism, sexual selection, and adaptation in polygenic characters. *Evolution* 34(2):292-305
- Langmore, N., and Bennett, A. (1999) Strategic concealment of sexual identity in an estrild finch. *Proceedings of the Royal Society: Biological Sciences* 266(1419):543-550
- LeBas, N., Hockham, L., and Ritchie, M. (2003) Nonlinear and correlational sexual selection on 'honest' female ornamentation. *Proceedings of the Royal Society of London, Series B* 270: 2159-2165
- Møller, A.P. (1988) Female choice selects for male sexual tail ornaments in the monogamous swallow. *Nature* 332:640-642
- Møller, A.P. (1992) Frequency of female copulations with multiple males and sexual selection. *The American Naturalist* 139: 1089-1101
- Olsson, M. (1993) Male preference for large females and assortative mating for body size in the sand lizard. *Behavioural Ecology and Sociobiology* 32(5):337-341
- Ord, T. and Stuart-Fox, D. (2006) Ornament evolution in dragon lizards: multiple gains and widespread losses reveal a complex history of evolutionary change. *European Society for Evolutionary Biology Journal Compilation* 19:797-808
- Parker, G. (1983) Mate quality and mating decisions. In Bateson, P (ed). *Mate Choice*. Cambridge University Press: Cambridge
- Petrie, M. (1983) Mate choice in role-reversed species. In Bateson, P (ed). *Mate Choice*. Cambridge University Press: Cambridge
- Pomiankowski, A., Denniff, M., Fowler, K., and Champman, T. (2005) The costs and benefits of high early mating rates in the male stalk-eyed flies, *Cryptodiopsis dalmanni*. *Journal of Insect Physiology* 51(10):1165-1171
- Pomiankowski, A., and Iwasa, Y. (1998) Runaway ornament diversity caused by Fisherian sexual selection. *Proceedings of the National Academy of Science in the USA* 95:5106-5111
- Proctor, H. 1991. Courtship in *Neumania* watermites: male capitalize on female adaptations for predation. *Animal Behaviour* 42:589-598
- Proctor, H. 1992. Mating behaviour and spermatophore morphology of watermites (Acari: Parasitengona). *Zoological Journal of the Linnaean Society* 106:341-384
- Reading, K. and Backwell, P. (2007) Can beggars be choosers? Male mate choice in a fiddler crab. *Animal Behaviour* 74: 867-872
- Servedio, M., and Lande, R. (2006) Population genetic models of male and mutual mate choice. *Evolution* 60(4):674-685
- South, S. (2007) Signal evolution via sexual selection- with special reference to sabethine mosquitoes. Introductory Research Essay No. 91, Uppsala University, Evolutionary Biology Centre, Department of Animal Ecology. ISSN 1404-4919
- South S. and Arnqvist, G. Evidence of monandry in a mosquito (*Sabethes cyaneus*) with elaborate ornaments in both sexes. (in press)
- Trail, P. (1990) Why should lek-breeders be monomorphic? *Evolution* 44: 1837-1852



- Trivers, R. (1972) Parental investment and sexual selection. In Campbell, B. (ed.) *Sexual Selection and the Descent of Man 1871-1971*. Aldine Publishing Company: Chicago.
- Vahed, K. (2007) All that glitters is not gold: sensory bias, sexual conflict and nuptial feeding in insects and spiders. *Ethology* 113: 105-127
- Verrel, P. 1995 Males choose larger females as mates in the salamander *Desmognathus santeelah*. *Ethology* 99: 162–171
- West-Eberhard, M. (1979) Sexual selection, social competition, and evolution. *Proceedings of the American Philosophical Society* 123: 222–234.
- West-Eberhard, 1983 M.J. West-Eberhard, Sexual selection, social competition, and speciation, *Quarterly Review of Biology* 58: 155–183
- Woods, W., Hendrickson, H., Mason, J., and Lewis, S. (2007) Energy and predation costs of firefly courtship signals. *The American Naturalist* 170(5): 702-708
- Yeh, P. (2004) Rapid evolution of a sexually selected trait following population establishment in a novel habitat. *Evolution* 58(1): 166-174
- Yuval, Boaz. (2006) Mating systems of blood-feeding flies. *Annual Review of Entomology* 51: 413-440
- Zahavi, A. (1975). Mate selection - a selection for a handicap. *Journal of Theoretical Biology* 53: 205–214.