

OPTICAL FIBERS FOR THE DISTRIBUTION OF
FREQUENCY AND TIMING REFERENCES *

George F. Lutes

Jet Propulsion Laboratory
California Institute of Technology
4800 Oak Grove Drive
Pasadena, California 91109
(213) 354-6210

ABSTRACT

An optical fiber communications link was installed for the purpose of evaluating the applicability of optical fiber technology to the distribution of frequency and timing reference signals. It incorporates a 1.5km length of optical fiber cable containing two multi-mode optical fibers. The two fibers were welded together at one end of the cable to attain a path length of 3km.

This paper reports preliminary measurements made on this link, including Allan Variance and power spectral density of phase noise.

INTRODUCTION

A three kilometer stabilized optical fiber distribution link for the dissemination of ultrastable reference frequencies has been demonstrated. The fractional frequency stability ($\Delta f/f$) of this link as a function of the sampling interval (τ) is compared to the stability of a Hydrogen maser in Figure 1.

The effective stability and accuracy of a frequency and/or timing standard is no better than the stability of the distribution system that delivers its output signal to the user. Therefore it is important to improve distribution systems simultaneously with improvements in the stability of frequency and timing standards.

This paper will begin with a discussion of three basic stabilized frequency distribution systems with variations and a description of a coaxial system that has been implemented. This will be followed by an

*This paper presents the results of one phase of research carried out at the Jet Propulsion Laboratory, California Institute of Technology, under Contract No. NAS7-100, sponsored by the National Aeronautics and Space Administration.

examination of error sources encountered in the implementation of these systems. Then the applicability of optical fiber technology to frequency and timing dissemination will be discussed. Finally the details of the stabilized optical fiber frequency distribution system which has been implemented, will be discussed, followed by possible future improvements.

Basic Systems

The three basic kinds of stabilized frequency distribution systems of the two way transmission type are shown in Figure 2(a), (b) and (c).

In each of these figures the forward and return signal paths are drawn separately but in practice the signals are transmitted both ways in the same signal path (coaxial cable, optical fiber, etc.). This is done to assure that the delay (τ) plus the change in delay ($\Delta\tau$) is the same in both directions. The change in delay, $\Delta\tau$, is caused by the effect of temperature variations, pressure changes and mechanical disturbances on the signal path.

In the feed-forward system shown in Figure 2(a), the phase difference between the input signal and the return signal is measured. This difference is divided by two and subtracted from the phase of the output signal. This can be done in a phase shifting device in series with the output signal as shown or in the users software.

In the feed-back system in Figure 2(b), the phase difference between the input signal and the return signal is held constant by controlling the phase shifter such that any change in delay ($2\Delta\tau$) is cancelled.

The phase of the input signal is changed, in the conjugation system shown in Figure 2(c), such that it is always the conjugate of the return signal relative to the zero phase of the reference signal. This forces the output phase to remain at zero.

There are four variations in the way the return signal is generated and each of them is applicable to any of the three basic systems.

The first way, shown in Figure 3(a), is to terminate the transmission line with a mismatch at the far end so that some of the signal is reflected back down the line.

A system was implemented by P. Clements, reference 1, in 1974 using this variation with the feedback system. The phase shift was accomplished by changing air pressure in an air dielectric coaxial cable.

In the second variation, shown in Figure 3b, the terminating impedance at the far end of the line is not only mismatched to the line, but is also varied (modulated) sinusoidally at a low frequency.

This causes the power of the reflected signal to vary with the modulating frequency, generating two sidebands on the return signal which are evenly spaced about the input frequency. This is done so the return signal can be separated, with filters, from the input reference signal. A more complicated form of detector is required, with this variation, to compare the return signal to the reference.

This variation was developed by A. Rogers, Reference 2, in the early 1970's, and was used first in the feed-forward system (Figure 2(a)) and later in the feed-back system (Figure 2(b)).

The last two variations, shown in Figure 3(c) and (d), are similar to the two variations previously discussed, except that the signals are received at the far end of the line and then filtered and amplified, and in the final variation, modulated and retransmitted back down the line. This results in a higher signal to noise ratio at the error detector and may in some cases result in better short term stability of the output signal.

A stabilized microwave distribution system using the modulated turn-around return signal variation with a conjugation system (Figure 2(c)) was developed by J. MacConnell and R. Sydnor in 1976-1977, Reference 3. Two such links were installed at the NASA Deep Space Network (DSN) Complex at Goldstone, California. They were connected end to end in opposite directions so that a signal could be transmitted over a 9 km distance by one link and returned to the origin over the other link. The return signal was compared to the reference to determine the stability. This data is shown in Figure 5.

Coaxial Cable System

The modulated turn-around variation was used in a negative feedback system that was implemented by the author in 1975 (reference 4). A block diagram of this system is shown in figure 4. It was used to stabilize a 300 meter length of coaxial cable and reduced a 10 cm length change on the cable to approximately 2 mm.

A 5 MHz reference frequency was transmitted through a directional coupler and a phase shifter down the coaxial cable to the far end where it was received and divided by 1000. The 5 KHz signal out of the frequency divider was used to modulate the received 5 MHz signal. The modulation resulted in a double sideband suppressed carrier signal that was transmitted back down the coaxial cable through the phase shifter to the directional coupler where it was separated from the forward signal and was directed to the detector. The phase of the return signal was compared, in the detector, to the phase of the reference signal and an error signal was generated that controlled the phase shifter to reduce the error.

Error Sources

One of the most difficult error sources to eliminate is the leakage of the input signal (reference) into the return signal path. This leakage can be due to inadequate isolation in the directional couplers or from the input signal being reflected back toward the source by intermediate reflections in the signal path. This reflection problem is particularly bad in a microwave transmission system, such as the one previously discussed, and makes it necessary to use gated detector techniques to reduce it.

In the case of the modulated return signal type of system, inadequate suppression of the carrier (reference signal) at the return port of the detector can be a source of error.

Drift in the error detector will not be reduced. Any change in the one way signal path will only be reduced by a factor of 2. Error detectors are generally sensitive to amplitude changes. These changes can have several causes and are most likely to occur on the return signal. If a standing wave exists on a transmission line, for example, small changes in the length of the line can cause relatively large changes in amplitude.

When the modulated return signal type of system is used, dispersion in the transmission medium, filters or phase shifter may cause an error by upsetting the phase relationship between the two sidebands and the carrier. This effect gets worse as the sidebands get further apart in frequency and as the distance increases.

Another problem that occurs in a modulated return signal type of system is the problem of eliminating the modulation frequency from the output signal.

Applicability of Optical Fiber Technology

Several characteristics associated with optical fibers can be used to advantage in the dissemination of frequency and timing references.

The change in propagation delay versus temperature is approximately 10 parts per million per degree centigrade. This is comparable to the most stable coaxial cables which are more expensive than fiber optic cable.

Multi-mode optical fibers with 1 GHz-km bandwidth are readily available. This is much greater than any practical coaxial cable.

A wide bandwidth provides the capability of disseminating a wide range of frequencies, possibly several simultaneously on the same fiber.

Wideband optical fibers exhibit low dispersion of 1 ns/km or less. Because of this there is much less spreading of timing pulses than is possible with coaxial cables. In stabilized frequency dissemination systems utilizing modulated return signals, the relationship between the generated sidebands and the carrier is affected much less than it would be in most other propagation media.

Optical fibers are available with optical losses of <3 dB/km at 850 nm wavelength. At 1,300 nm wavelength the loss can be <0.5 dB/km. Laser diodes that operate at this wavelength will soon be available as will diodes capable of much more output power than the typical 1 to 5 milliwatts of C.W. optical power generated with presently available devices.

Solid state laser diode transmitters are available that have modulation bandwidths greater than 1 GHz, and can be linearly or digitally modulated. Receivers are available with a bandwidth from D.C. to 3 GHz.

Optical fibers do not radiate or pick up RFI or EMI. This can be a major source of noise in other propagation mediums.

Electrical isolation can be maintained between an optical transmitter and receiver, thereby eliminating ground loops.

Optical fiber cables are small, lightweight and corrosion resistant.

The installation of optical fiber cables is comparable to coaxial cables; discontinuities can readily be located using an optical time domain reflectometer; and they can be repaired by welding, even in an adverse field environment. Repairs can be made with no more difficulty than repairing coaxial cables.

Directional couplers are available with isolation greater than 80 dB and signals can be transmitted in both directions in an optical link at the same frequency with extremely high isolation between them.

Optical Fiber System

The subject optical fiber link consists of a commercial optical transmitter and receiver and a 1.5 km length of two conductor optical fiber cable.

About 1.5 mW of optical power is emitted, by the optical transmitter, at a wavelength of ≈ 830 nm. The output can be linearly amplitude modulated from 20 Hz to 1.2 GHz.

The modulation frequency response of the receiver is from D.C. to 3 GHz and the gain can be controlled over a 40 dB range.

The cable contains two optical fibers of the multimode graded index type with a bandwidth of 400 MHz-km and 6 dB/km loss. The outside diameter of the fibers is 125 μm with a 62.5 μm core diameter.

The two fibers are welded together at the far end of the cable to attain a round trip signal path length of 3 km.

A directional coupler has been welded to each of the fibers at the near end. This provides an input and an output for each fiber to which a receiver and transmitter has been connected. In this configuration there are two separate links, operating in opposite directions, sharing the same fiber. If the output of one link is connected to the input of the second link a path length of 6 km is attained. The separation between these links is >60 dB. There are 15 welded splices and two connectors in the fiber in this configuration.

The instantaneous bandwidth of each 3 km link is limited by the fiber to 130 MHz. One way (3 km) signal loss in the fiber is 24 dB. The power spectral density of phase noise (reference 4) is ≈ 120 dBc in a 1 Hz bandwidth, 10 Hz from a 100 MHz signal.

Intermodulation distortion products are down more than 40 dBc for two signals separated by 1 kHz around 25 MHz and with a modulation depth of 70%.

A stabilized optical fiber frequency distribution system could be implemented by merely inserting an optical fiber two way link, as described above, between the ends of the stabilized coaxial system shown in figure 4. The result of this would be the system shown in figure 6. However, for most applications, the simpler system shown in figure 7 may be used.

This simplification is made possible by the high degree of isolation between the forward and reverse signals and the relative freedom from reflections in the optical portion of the system.

The stabilizer is of the conjugation type using the nonmodulated turn-around method to generate the return signal. It was breadboarded with individually packaged building blocks such as amplifiers, mixers, low pass filters and operational amplifiers, and no attempt was made to protect them from normal variations in room temperature.

It has been determined that further improvement in the stability of the distribution system is limited by the noise of the optical transmitters and/or the optical receivers being used. Significant improvements in the stability of these devices should be possible.

If the input frequency is changed by some Δf and the resultant phase change $\Delta\phi$ across the phase shifter is carefully measured, the absolute

time delay of the line can be determined, thus eliminating the modulo uncertainty. Once this is done the input frequency can be fixed and the phase across the phase shifter will be a precise indication of the time delay down the link. The link can then be used to transfer very accurate timing signals.

Future Plans

Several problems will be given immediate attention. An effort must be undertaken to reduce the noise of the optical transmitters and/or receivers. Of equal importance is the need to better understand the problem of propagation delay versus bending in optical fibers (reference 6).

Single-mode optical fibers appear to be better in nearly every respect to multimode optical fibers for this application, but the problem of coupling light into the $\approx 10 \mu\text{m}$ core must be resolved. An effort is being started in this area at JPL/CIT.

Work will be continued on the development of optical components such as an R.F. optical phase shifter (reference 5) which shifts the phase of the R.F. modulation on the optical carrier. This will further simplify the stabilized distribution link.

Conclusion

The present capability is adequate for many applications but several refinements are needed to achieve our goal of distributing reference frequencies with a stability of 3 parts in 10^{16} , at averaging times greater than 100 seconds, over a distance of 20 km without appreciably degrading them.

Reference 1 - A personal discussion with P. Clements at JPL, Nov. 1980.

Reference 2 - A. Rogers, "A Receiver Phase and Group Delay Calibrator for Use in Very Long Baseline Interferometry," Haystack Observatory Technical Note 1975-6.

Reference 3 - J.W. MacConnell, R.L. Sydnor, "A Microwave Frequency Distribution Technique for Ultrastable Standard Frequencies," The JPL Deep Space Network Progress Report, 42-28, pp. 34-41, Jet Propulsion Laboratory, Pasadena, Ca., Aug. 15, 1975.

Reference 4 - G. Lutes, "A Transmission Line Stabilizer," The Deep Space Network Progress Report, 42-51, pp. 67-74, Jet Propulsion Laboratory, Pasadena, Ca., June 15, 1979.

Reference 5 - K.Y. Lau, "A Voltage-Controlled Optical Radio Frequency-Phase Shifter," The Deep Space Network Progress Report 42-53, pp. 24-32, Jet Propulsion Laboratory, Pasadena, Ca., Oct. 15, 1979.

Reference 6 - K.Y. Lau, "Propagation Path Length Variations Due to Bending of Optical Fibers," to be published.

RUN: B2. 2A
TSP: 3. 16
ALLAN VARIANCE
SIGMA (N, T, B, TAU)

N = 2
T = TAU
B = 1 Hz
fo = 100.0 MHz

SA014 - SA06

START: 1720: 07-13-80
END: 0710: 07-14-80
CHANNEL: 1

670

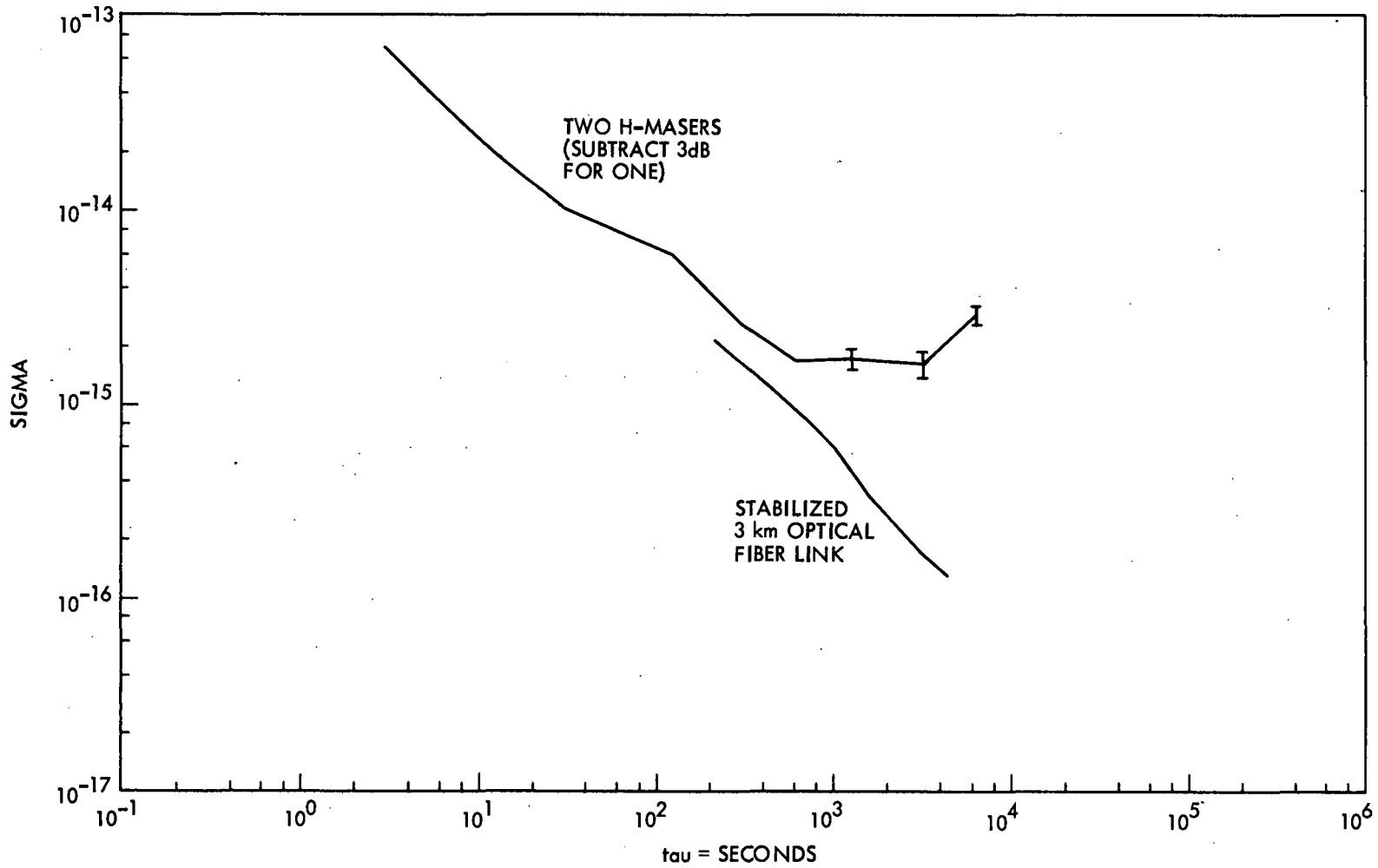

Figure 1. Stabilized Optical Fiber Link Compared to a H-Maser

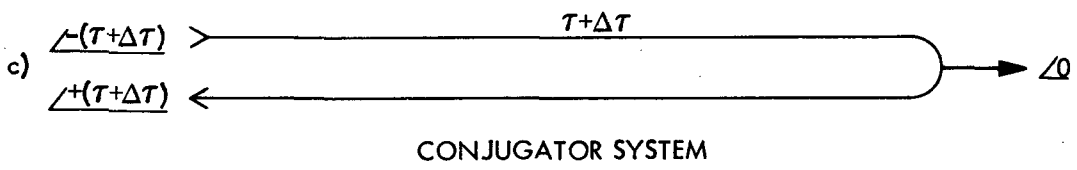
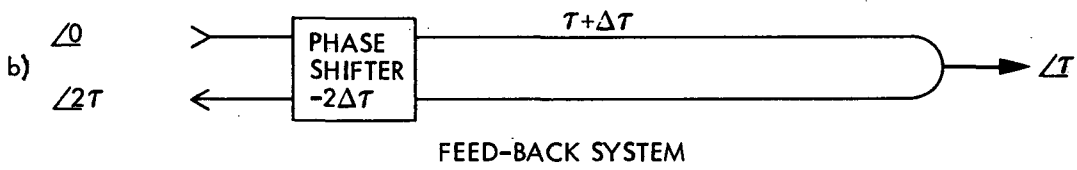
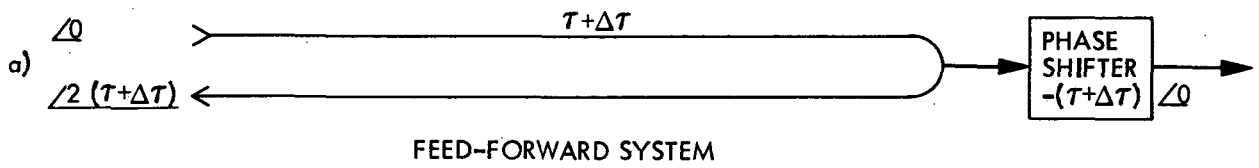

Figure 2. Basic Two Way Transmission Stabilization Systems

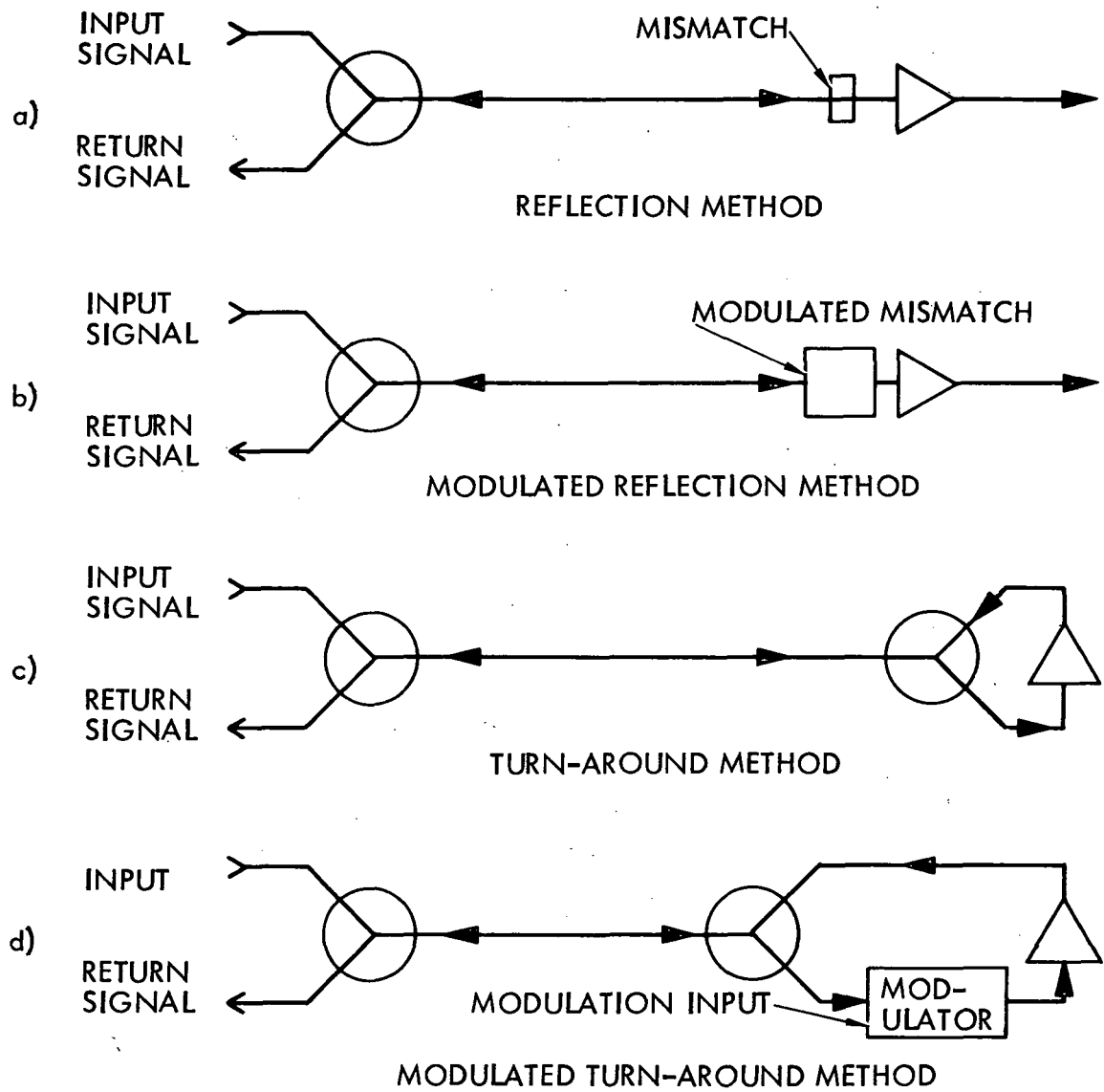

Figure 3. Return Signal Generation Variations

STABILIZED COAXIAL CABLE SYSTEM

673

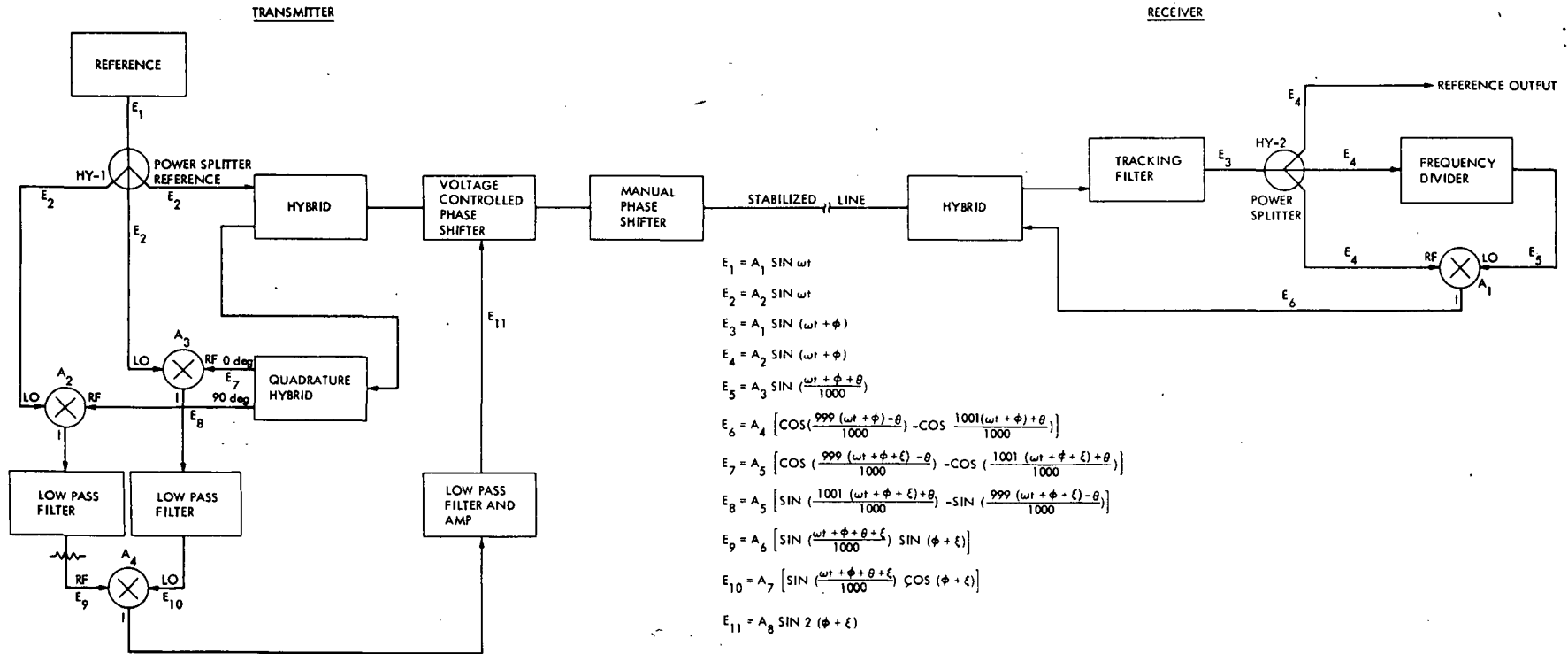

Figure 4. Stabilized Coaxial System

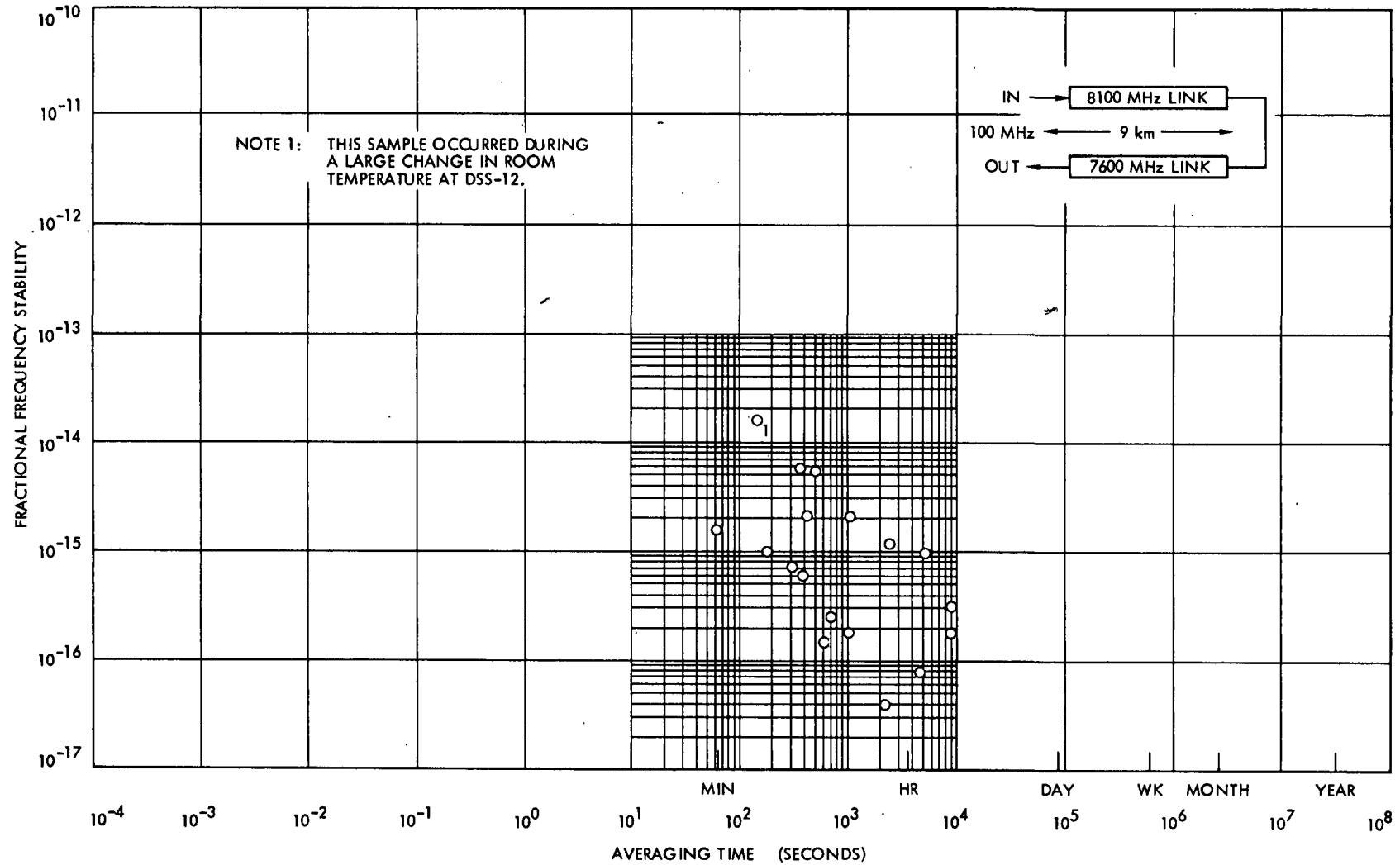

Figure 5. Worst Case Samples of the Fractional Frequency Stability for Two Phase Stabilized Microwave Links Connected in Series Over a Total Distance of 18 km

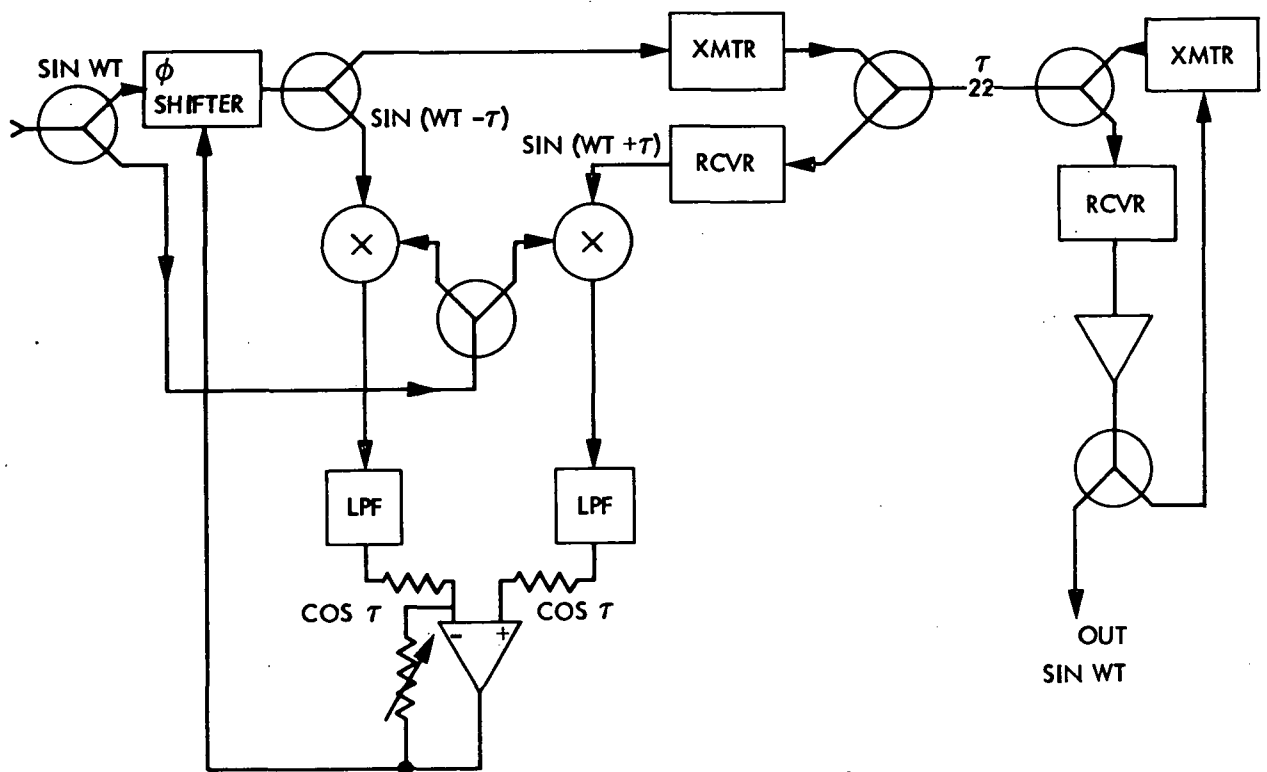

Figure 7. Present 3 km Optical Fiber Stabilized Distribution Link

QUESTIONS AND ANSWERS

DR. VICTOR REINHARDT, NASA/Goddard

What are you achieving with the optical fibers?

DR. LUTES:

We are achieving the curve shown in the second viewgraph. Why don't we show that again?

This curve is the stability we are achieving at the present time. That stability is limited right now since changes in the one-way signal path due to the optical transmitter and/or receivers are compensated by a factor of two. They are causing the limit at the present time.

Improvements in those devices should improve this considerably.

DR. REINHARDT:

What is that about?

DR. LUTES:

This is 225 seconds sampling interval, which is about four parts in 10^{15} . Down here is 4,000 seconds, somewhere around a part in 10^{16} .

PROFESSOR LESCHIUTTA:

We have established a more simple system in my laboratory but we are plagued with the problem of reliability of transmitting diodes. What is your experience of the useful life of the transmitting diodes? Thank you very much.

DR. LUTES:

We have had no failures in transmitting diodes. We had some failures in the receivers which are state-of-the-art receivers as far as bandwidth goes, probably not as far as noise goes though. The laser diodes are guaranteed for 10,000 hours mean time between failure. They are expected to last much longer than that. The projected life is well over 50,000 hours mean time between failures.

PROFESSOR CARROLL ALLEY, University of Maryland

Have you had any experience in transmitting ultra short pulses of light over these optical fibers for strictly timing comparisons?

DR. LUTES:

Yes, we have run some experiments where we transmitted pulses that were about 30 picoseconds in width over short distances, but not over this particular length. That is as short a pulse as we can resolve with our receiver.

PROFESSOR ALLEY:

What kind of spreading did you observe? You mentioned one nano-second dispersion over a kilometer. Is that an observed quantity?

DR. LUTES:

We haven't transmitted these over a line length of that distance so we don't know. We would expect from the experience we have that it is somewhere very close to one nanosecond or better for a kilometer. Actually, for very long lines it gets better than that. Most of the dispersion takes place in the first kilometer. Then, after that, it gets somewhat better.

PROFESSOR ALLEY:

I might comment for the possible interest of the group that we have recently been transmitting 100 picosecond pulses over a 25 kilometer distance without fibers using a mirror upon the Washington Cathedral and one on a water tower near Goddard in order to compare times between the Goddard Optical Research site and the Naval Observatory.

We are hoping for a 100 picosecond resolution in this system once it is completely worked out. Thank you.

DR. LUTES:

Yes, we have done some work in the area determining how long the propagation delay on these lines are. One way of getting rid of the module ambiguity is to change the frequency slightly and measure the phase. This we can do very well with the measuring techniques that have been developed.

Once we get rid of the module of ambiguity, then we can just look at the phase of the error and further resolve the length of the line. We can resolve the length of the line in this case to about a picosecond for a three kilometer system.

DR. BOB COATES, NASA/Goddard

I am interested in the performance of optical connectors in such a fiber length. Did your link have connectors in it and what are their stability?

DR. LUTES:

For the link that we showed here, most of the connections were welded connections. We have 11 welded connections and two connectors. The only place that we use connectors in this link are at the receivers. The reason that we can get away with it there is that the detector area is fairly large compared to the core diameter of the optical fiber so that the alignment is not very critical. Everywhere else we use welded connections, and the average loss (we haven't measured the actual loss at the connectors because there is some difficulties involved in doing it on short pieces of fiber) is less than half a dB per splice.

It is probably more like a tenth of a dB or less.

DR. TOM CLARK, NASA/Goddard

You alluded to information on the performance of these fibers under bending and that one is our concern, too, because many of the applications do require you to be able to bend cables. Could you comment on that?

DR. LUTES:

With multi-mode fibers, there appears to be a problem with bending and this problem can result in the phase propagation in the two directions on the line not being reciprocal. Therefore, these systems will not cancel that kind of a difference.

We suspect this is not true for single mode fibers, although we haven't actually made measurements to validate this. We are somewhat worried about this problem, also.

VOICE:

At what frequencies?

DR. LUTES:

You can see about two degrees at 100 megahertz for short-bending radiuses of three or four centimeters. It is very obvious when you do bend the fiber; it is more sensitive toward the receivers

of the fiber than it is further away. This is because of the way that this effect occurs. It is a moding effect and once the moding stabilizes, the effect is no longer there and the line becomes reciprocal. So any bends within one kilometer from the transmitter of multi-mode fiber is a problem.

However, we suspect it is not with single mode fiber because there are no other modes to add to the phase or subtract from phase.