

# Optical flip-flop based on two-coupled mode-locked ring lasers

**Citation for published version (APA):**

Tangdionga, E., Yang, X., Li, Z., Liu, Y., Lenstra, D., Khoe, G. D., & Dorren, H. J. S. (2005). Optical flip-flop based on two-coupled mode-locked ring lasers. *IEEE Photonics Technology Letters*, 17(1), 208-210.  
<https://doi.org/10.1109/LPT.2004.837742>

**DOI:**

[10.1109/LPT.2004.837742](https://doi.org/10.1109/LPT.2004.837742)

**Document status and date:**

Published: 01/01/2005

**Document Version:**

Publisher's PDF, also known as Version of Record (includes final page, issue and volume numbers)

**Please check the document version of this publication:**

- A submitted manuscript is the version of the article upon submission and before peer-review. There can be important differences between the submitted version and the official published version of record. People interested in the research are advised to contact the author for the final version of the publication, or visit the DOI to the publisher's website.
- The final author version and the galley proof are versions of the publication after peer review.
- The final published version features the final layout of the paper including the volume, issue and page numbers.

[Link to publication](#)

**General rights**

Copyright and moral rights for the publications made accessible in the public portal are retained by the authors and/or other copyright owners and it is a condition of accessing publications that users recognise and abide by the legal requirements associated with these rights.

- Users may download and print one copy of any publication from the public portal for the purpose of private study or research.
- You may not further distribute the material or use it for any profit-making activity or commercial gain
- You may freely distribute the URL identifying the publication in the public portal.

If the publication is distributed under the terms of Article 25fa of the Dutch Copyright Act, indicated by the "Taverne" license above, please follow below link for the End User Agreement:

[www.tue.nl/taverne](http://www.tue.nl/taverne)

**Take down policy**

If you believe that this document breaches copyright please contact us at:

[openaccess@tue.nl](mailto:openaccess@tue.nl)

providing details and we will investigate your claim.

# Optical Flip-Flop Based on Two-Coupled Mode-Locked Ring Lasers

Eduward Tangdionga, Xuelin Yang, Zhonggui Li, Yong Liu, *Student Member, IEEE*, Daan Lenstra, *Member, IEEE*, Giok-Djan Khoe, *Fellow, IEEE*, and Harm J. S. Dorren, *Member, IEEE*

**Abstract**—We report an all-optical flip-flop that is based on two coupled actively mode-locked fiber ring lasers. The lasers are coupled so that when one of the lasers lases, it quenches lasing in the other laser. The state of the flip-flop is determined by the wavelength of the laser that is currently lasing. The concept of the flip-flop is explained and experimental results are presented that indicate a flip-flop operation over 25-dB contrast ratio and less than 0.3-mW switching power.

**Index Terms**—Flip-flop memories, optical bistability, packet switching, semiconductor optical amplifiers (SOAs).

## I. INTRODUCTION

OPTICAL flip-flop memories have been extensively investigated as they have potential applications in all-optical packet switches for futuristic telecommunication nodes. In [1], an optical packet switch is presented that consists of three optical functional building blocks: an optical header recognizer, an optical flip-flop memory, and a wavelength converter. The role of the optical flip-flop memory is to store the processed header information for the duration of the packet, and to generate a continuous-wave (CW) control signal that drives the wavelength converter.

Transmission systems operating at bit rates of higher than 100 Gb/s usually transmit return-to-zero bits with duration of a few picoseconds. Reference [2] describes an optical packet switch for such a system. An optical decision element that controls a packet switch in a return-to-zero transmission system has to satisfy two conditions. First, it has to generate short optical pulses to establish switching. Second, the switching time should be sufficiently short to ensure the transmission of short packets and to allow short guard times. An all-optical flip-flop (AOFF) could act as such an ultrafast decision element for an optical packet switch. The flip-flop concept that we present in this letter outputs optical pulses with a duration of a few picoseconds.

Manuscript received July 6, 2004; revised August 25, 2004. This work was supported by the Netherlands Organization for Scientific Research (NWO), the Technology Foundation STW, and by the Ministry of Economic Affairs through, respectively, the NRC Photonics Grant and the Innovational Research Incentives Scheme Program.

E. Tangdionga, X. Yang, Z. Li, Y. Liu, G.-D. Khoe, and H. J. S. Dorren are with the COBRA Research Institute, Eindhoven University of Technology, Electro-optical Communication, Eindhoven NL-5600 MB, The Netherlands (e-mail: E.Tangdionga@tue.nl; X.Yang@tue.nl; Z.Li@tue.nl; Y.Liu@tue.nl; D.Lenstra@tue.nl; G.D.Khoe@tue.nl; H.J.S.Dorren@tue.nl).

D. Lenstra is with the COBRA Research Institute, Eindhoven University of Technology, Electro-optical Communication, Eindhoven NL-5600 MB, The Netherlands, and also with Vrije Universiteit, FEW, Department of Physics and Astronomy, Amsterdam NL-1081 HV, The Netherlands (e-mail: D.Lenstra@few.vu.nl).

Digital Object Identifier 10.1109/LPT.2004.837742

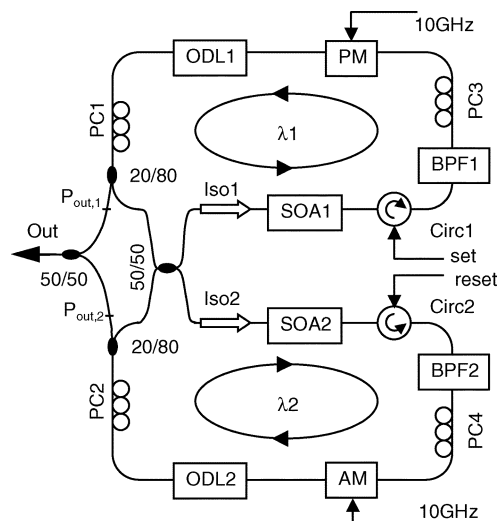

Fig. 1. Schematic of AOFF based on two coupled ring lasers. Circ: optical circulator.

Several forms of optical bistability can be applied in optical flip-flop memories [3]. We use a bistability concept that is based on quenching the gain of a semiconductor laser by externally injected light [4]. AOFFs based on this principle that output CW-light have been demonstrated by coupling two lasers in a master-slave configuration [5].

In this letter, we give proof of concept of an AOFF that is based on two coupled actively mode-locked ring lasers (MLRLs) that form a symmetric master-slave configuration. This flip-flop outputs optical pulses with duration of 3–4 ps at a repetition rate of 10 GHz. The flip-flop is made out of commercially available fiber pig-tailed components. We present flip-flop operation with a contrast ratio between the states of 25 dB. The flip-flop can be optically set and reset at the expense of 0.3 mW of power. A discussion about ultrafast switching behavior is given. The letter is organized as follows. In Section II, the system concept is explained. Experimental results are presented in Section III. Discussion and conclusion are in Section IV.

## II. SYSTEM CONCEPT

Fig. 1 presents a schematic of the AOFF. The system consists of two-coupled lasers operating at central wavelengths  $\lambda_1$  and  $\lambda_2$ , respectively. Each cavity contains a phase or amplitude modulator (AM/PM), an optical delay line (ODL), an isolator (Iso), a bandpass filter (BPF), a semiconductor optical amplifier (SOA), a circulator, and polarization controllers (PCs). The total length

of each cavity was approximately 20 m. We used two bulk InGaAsP–InP SOAs with a 800- $\mu\text{m}$ -long active region. The SOAs have an optimum gain at 1537 and 1547 nm, respectively, and they can provide 23-dB small-signal gain at a bias current of approximately 300 mA. In both ring cavities, the SOA exhibits a polarization sensitivity of 2 dB, while the polarization sensitivity of the AM and PM modules was 3–4 dB. The polarization dependencies were compensated by using PCs. The Iso's were used to ensure unidirectional lasing. The BPF [5 nm, full-width at half-maximum (FWHM)] defined the central wavelength of each cavity and the ODL was used to precisely match multiples of the cavity resonance frequency to the repetition rate. The total cavity loss was 10–13 dB and its cavity fundamental frequency was 6.698 MHz. Note that there is no specific reason for using different modulators in the MLRLs. It is important, however, that the pulsewidths and optical powers in each ring are identical to allow symmetric coupling.

Flip-flop operation was realized by symmetrically connecting the two cavities such that one laser acts as a master, suppressing the other laser, which consequently acts as a slave. The role of master and slave can be interchanged due to the system symmetry. Thus, the system has two states, depending on which laser is lasing. The state can be determined by the wavelength of the output light. To switch between the states, external light has to be injected into the master. The external light quenches the gain of the master so that lasing is stopped. The absence of light from the master laser allows the slave laser to start lasing to become the master. The flip-flop remains in the new state after the external light has been removed.

### III. EXPERIMENTS AND RESULTS

To operate each ring laser in the harmonic mode-locking condition, the external modulation frequency should be exactly equal to an integer multiple of the cavity fundamental frequency. This can be achieved by fine-tuning the cavity length with the ODL. The ring then generates pulses with an FWHM duration of around 3–4 ps that have an FWHM bandwidth of 2 nm. The pulses observed with an autocorrelator were fairly  $\text{sech}^2$  but they were not transform limited because of the combined effect of self-phase modulation in the SOA and dispersion in the fiber. Laser 1 and Laser 2 output light at central wavelengths of 1537 and 1547 nm, respectively. SOA1 was biased with 170 mA of current and the SOA2 was 300 mA. The asymmetry in the bias currents was caused by the difference in the laser cavity losses. The average power inside the cavity of the master laser was about 1 mW for 170 mA of bias current.

The static contrast ratio between the two states of the AOFF was investigated by using an optical spectrum analyzer. Fig. 2 shows that static contrast ratio between states of the flip-flop is larger than 25 dB. In order to change between the AOFF states, external light with a wavelength within the SOA spectral range is injected into the laser that was currently the master. We used CW light with a central wavelength of 1550 nm to stop the lasing of the master. This allows the slave to recover and to become the master. A typical curve that shows the averaged optical power in each cavity as a function of the externally injected power is shown in Fig. 3. The operational regions (*A*, *T*, *B*) indicated in

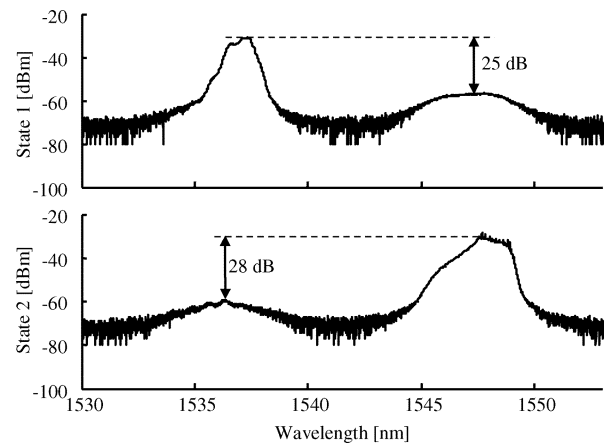

Fig. 2. Optical spectra of the two-state flip-flop operation of the two-coupled ring laser structure.

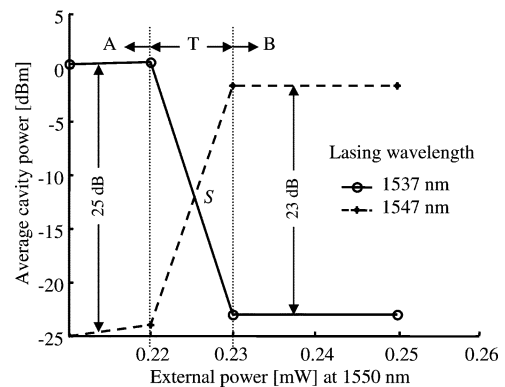

Fig. 3. Optical power in the laser cavities as function of an external injection power around the transition states. Regions *A* and *B* represent stable states. *T* is a transition region.

Fig. 3 represent the steady-state solutions of the system. State 1 is determined by the region labeled *A* in which laser  $\lambda_1$  dominates and laser  $\lambda_2$  is suppressed. Similarly, Region *B* defines State 2, in which laser  $\lambda_2$  suppresses laser  $\lambda_1$ . It turned out that the system is stable in both Regions *A* and *B*. Switching between State 1 and State 2 takes place in the transition region *T*. It follows from Fig. 3 that if the externally injected power exceeds 0.22 mW, the power in the dominant cavity drops and the power in the suppressed cavity increases. The transition point  $S = 0.225$  mW causes an identical power level of  $-12$  dBm in both cavities. If the injected power is greater than 0.23 mW, the dominant laser is switched OFF and the suppressed laser is switched ON. The contrast ratio between the ON and OFF states is 23 dB. Once switching has occurred, the AOFF remains stable, also after the external light is removed.

The average external power to change the AOFF state critically depends on wavelength detuning with respect to the SOA gain maximum. This is illustrated in Fig. 4, where the wavelength dependence of the switching is shown in case of externally injected light at two different wavelengths. The central wavelength of the first beam was 1530 nm ( $-7$ -nm detuning), while the central wavelength of the other beam was 1550 nm ( $+13$ -nm detuning). It is clearly visible that in order to decrease the lasing power by more than 25 dB, 2.1 dB more power is

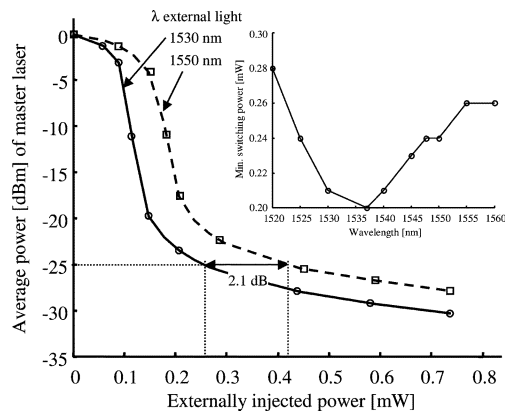

Fig. 4. Average power of the master cavity versus external injection optical powers for CW light wavelength of 1530 and 1550 nm. Inset is the wavelength-dependent minimum average power required for switching OFF the master laser.

required if the wavelength was 1550 nm. For the other wavelengths, the minimum power required for switching is depicted in the inset of Fig. 4. The CW light was generated by a tunable laser that is scanned between 1520 and 1560 nm. Within a wavelength range of 40 nm, we observed a minimum value CW power of 0.2-mW optical power at a wavelength of 1537 nm to switch OFF the master laser. The spread in the required switching power was smaller than 0.1 mW.

The wavelength of the system should be selected such that there is no spectral overlap between the two states. It is desirable but not essential to select the wavelengths near the SOA gain peaks. If the detuning with respect to the gain peak is large, the switching between the states required higher power. The optical power in the laser cavities was too low to instigate nonlinear system penalties, such as four-wave mixing.

The flip-flop switching speed is determined by the length of the cavities and the distance between the ring lasers. Since our setup was implemented using fiber-pigtailed components, each laser had a cavity length of about 20 m and the distance between the lasers was 3 m. This implies that the switching speed was in the order of microseconds.

The dynamic operation of the AOFF was investigated by injecting a regular sequence amplitude modulated ones and zeroes in the laser that was currently the master. This causes the AOFF to change its state after a certain amount of time. The duration of each one and zero was 10  $\mu$ s, the central wavelength of this signal was 1551 nm, and the average power was 1 mW. The AOFF output was detected by a slow photodetector and displayed on an oscilloscope. Due to the limitation of the detector response time, Fig. 5 shows only the envelope of the picosecond pulse train. It should be noted, however, that each one-state consists of a sequence of optical pulses with duration of 3–4 ps (see inset) at a repetition rate of 10 GHz. We found that the flip-flop could change state in less than 2  $\mu$ s (see the risetime–falltime in Fig. 5). This implies that pulses can build up after about 20–30 round-trip times.

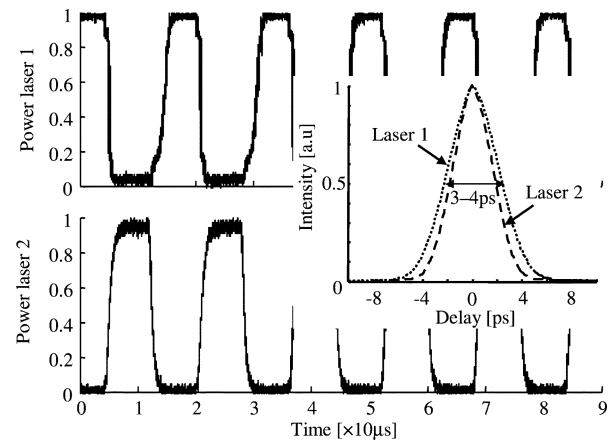

Fig. 5. Regular switching between two flip-flop states as a result of the set–reset signal. The inset shows typical pulse shapes of the MLRLs.

#### IV. DISCUSSION AND CONCLUSION

The AOFF generated a 10-GHz mode-locked pulse train and it could change its states within 2  $\mu$ s. This implies that the flip-flop could be used in 10-Gb/s networks for a minimum optical packet length of 20 000 bits. Shorter packets can be achieved by shortening laser cavities. In order to apply this AOFF in ultrafast optical networks, photonic integration of the concept is required. We would like to remark that the concept that we present can be implemented in many technologies. Compact mode-locked lasers that output short optical pulses at repetition rates up to 40 GHz have been presented by others, i.e., [6] and [7]. The cavity length of these devices could be made smaller than 1 mm. In principle, flip-flop operation could be obtained by symmetrically coupling two of these devices. Assuming that it takes about 20 round-trip times to build up lasing, such a system could switch in less than 200 ps.

In conclusion, based on its switching performance, this flip-flop concept forms a strong candidate for future optical packet switches.

#### REFERENCES

- [1] M. T. Hill, A. Srivatsa, N. Calabretta, Y. Liu, H. de Waardt, G. D. Khoe, and H. J. S. Dorren, "1  $\times$  2 optical packet switch using all-optical header processing," *Electron. Lett.*, vol. 37, pp. 774–775, Jun. 2001.
- [2] D. Cotter, J. K. Lucek, M. Shabeer, K. Smith, D. C. Rogers, D. Nessel, and P. Gunning, "Self-routing of 100 Gb/s packets using 6 bit 'keyword' address recognition," *Electron. Lett.*, vol. 31, pp. 2201–2202, Dec. 1995.
- [3] H. Kawaguchi, "Bistable laser diodes and their applications: State of the art," *IEEE J. Sel. Topics Quantum Electron.*, vol. 3, pp. 1254–1270, Oct. 1997.
- [4] G. J. Lasher and A. B. Fowler, "Mutually quenched injection lasers as bistable devices," *IBM J. Res. and Dev.*, vol. 8, pp. 471–475, Sep. 1964.
- [5] M. T. Hill, H. de Waardt, G. D. Khoe, and H. J. S. Dorren, "All-optical flip-flop based on coupled laser diodes," *IEEE J. Quantum Electron.*, vol. 37, pp. 405–413, Mar. 2001.
- [6] S. C. Zeller, L. Krainer, G. J. Spühler, R. Paschotta, M. Golling, D. Ebling, K. J. Weingarten, and U. Keller, "Passively modelocked 50 GHz Er:Yb:glass laser," *Electron. Lett.*, vol. 40, pp. 875–876, Jul. 2004.
- [7] R. Kaiser, B. Hüttl, H. Heidrich, S. Fidorra, W. Rehbein, H. Stolpe, R. Stenzel, W. Ebert, and G. Sahin, "Tunable monolithic mode-locked lasers on InP with low timing jitter," *IEEE Photon. Technol. Lett.*, vol. 15, no. 5, pp. 634–636, May 2003.