

# Optimal allocation of multi-type FACTS Controllers by using hybrid PSO for Total Transfer Capability Enhancement

Suppakarn Chansareewittaya<sup>1</sup> and Peerapol Jirapong<sup>2</sup>, Non-members

## ABSTRACT

In this paper, the new hybrid particle swarm optimization (hybrid-PSO) based on particle swarm optimization (PSO), evolutionary programming (EP), and tabu search (TS) is developed. Hybrid-PSO is proposed to determine the optimal allocation of multi-type flexible AC transmission system (FACTS) controllers for simultaneously maximizing the power transfer capability of power transactions between generators and loads in power systems without violating system constraints. The particular optimal allocation includes optimal types, locations, and parameter settings. Four types of FACTS controllers consist of thyristor-controlled series capacitor (TCSC), thyristor-controlled phase shifter (TCPS), static var compensator (SVC), and unified power flow controller (UPFC). Power transfer capability determinations are calculated based on optimal power flow (OPF) technique. Test results on IEEE RTS 24-bus system, IEEE 30-bus system and, IEEE 118-bus system indicate that optimally placed OPF with FACTS controllers by the hybrid-PSO could enhance the higher power transfer capability more than those from EP and conventional PSO.

**Keywords:** FACTS Controller, Particle Swarm Optimization, Tabu Search, Evolutionary Programming, Optimal Power Flow, Hybrid Method

## 1. INTRODUCTION

According to demands for electrical power energy which have increased every year, the installation of new electrical power plants or transmission networks can reach these requirements. However, it may take several years from the initial planning and designing throughout construction. Moreover, the pollution control, high cost of installations and operations, and the land acquisitions may be the disadvantages of these utilities. Therefore, to meet those increasing electricity consumption and demand, improving of existing electricity power generation sys-

tem is much reasonably appropriated and can be applicable for many parts of the world. The alternative and advantage solutions to respond these increasing demands are to improve the efficiency of power transfer capability in the power system using Flexible AC Transmission System (FACTS) [1]. The advantages of FACTS include less cost of installations and operations, operating with none pollution, and providing flexible control of the existing transmission system [2].

FACTS controllers are power electronics based system and other static equipment that have the capability of controlling various electrical parameters in transmission networks [3]. These parameters can be adjusted to provide adaptability conditions of transmission network [4, 5]. There are many types of FACTS controllers such as thyristor-controlled series capacitor (TCSC), static var compensator (SVC), thyristor-controlled phase shifter (TCPS), and unified power flow controller (UPFC) [6]. These FACTS controllers have been proved to be used for enhancing system controllability resulted in total transfer capability (TTC) enhancement and minimizing power losses in transmission networks [7, 8].

Total transfer capability (TTC) is defined as an amount of electric power that can be transferred over the interconnected transmission network in a reliable manner while meeting all of a set of defined pre- and post-contingency system conditions [9].

The maximum performance of using FACTS controllers to increase TTC and to minimize system losses should be obtained by choosing suitable types, locations, and parameter settings [10, 11]. The modern heuristics optimization techniques such as evolutionary programming (EP) [12], tabu search (TS) [13], genetic algorithm (GA) [14], and particle swarm optimization (PSO) [15] are successfully implemented to solve complex problems efficiently and effectively [16]. In [17], EP is used to determine the optimal allocation of four types of FACTS controllers. Test results indicated that optimally placed OPF with FACTS controllers by EP can enhance the TTC more than OPF without FACTS controllers. In [18], TS is used to tested and examined with different objectives and different classes of generator cost functions to demonstrate its effectiveness and robustness. The results using the TS approach are compared with evolutionary programming and non-linear programming

Manuscript received on July 7, 2014 ; revised on January 28, 2015.

Final manuscript received February 27, 2015.

<sup>1,2</sup> The authors are with Department of Electrical Engineering, Faculty of Engineering, Chiang Mai University, Chiang Mai, Thailand., E-mail: suppakarn.c@hotmail.com and peerapol@ee.eng.cmu.ac.th

techniques. It is clear that the TS approach outperforms the classical and evolutionary algorithms. In [19], both GA and PSO are used to optimize the parameters of TCSC. However, there are more advantageous performances of the PSO than those of GA. PSO seems to arrive at its final parameter values in fewer generations than GA. PSO gives a better balanced mechanism and better adaptation to the global and local exploration abilities [20]. Furthermore, it can be applied to solve various optimization problems in electrical power system such as power system stability enhancement and capacitor placement problems [21-25].

On the other hand, these modern heuristic methods have their limitations. Most of used control variables may define to the local values which give the almost local answer values. Therefore, in this paper, the new hybrid-PSO is developed. The aims of merging PSO, EP, and TS are to solve those limitations and merge their advantages. The proposed hybrid-PSO is used to determine locations, and parameter settings of four types of FACTS controller (TCSC, TCPS, SVC, and UPFC) to conduct TTC enhancement. The IEEE RTS 24-bus system, IEEE 30-bus system, and IEEE 118-bus system are used as the test systems. Test results are compared with those from EP and conventional PSO.

## 2. PROBLEM FORMULATION

To determine the optimal number and allocation of FACTS controllers for TTC enhancement and power losses reduction, the objective function is formulated as maximization of TTC by (1). Power transfer capability is defined as TTC value : the sum of real power loads in the load buses at the maximum power transfer. TTC value can be transferred from generators in source buses to load buses in power systems subjected to real and reactive power generations limits, voltage limits, line flow limits, and FACTS controllers operating limits.

Four types of FACTS controllers include: thyristor-controlled series capacitor (TCSC), thyristor-controlled phase shifter (TCPS), unified power flow controller (UPFC), and static var compensator (SVC). TCSC is modeled by the adjustable series reactance. TCPS and UPFC are modeled using the injected power model [26]. SVC is modeled as shunt-connected static var generator or absorber.

Maximize

$$F = \sum_{i=1}^{ND\_SNK} P_{Di} + \sum_{i=1}^{ND\_SNK} P_{LOSSi} - \sum_{i=1}^{NG} P_{Gi} \quad (1)$$

Subject to

$$P_{Gi} - P_{Di} + \sum_{k=1}^{m(i)} P_{Pi}(\alpha_{Pk}) + \sum_{k=1}^{m(i)} P_{Ui}(V_{Uk}, \alpha_{Uk}) - \sum_{j=1}^N V_i V_j Y_{ij}(X_{Si}) \cos(\theta_{ij}(X_{Si}) - \delta_i + \delta_j) = 0 \quad (2)$$

$$Q_{Gi} - Q_{Di} + \sum_{k=1}^{m(i)} Q_{Pi}(\alpha_{Pk}) + \sum_{k=1}^{n(i)} Q_{Ui}(V_{Uk}, \alpha_{Uk}) + Q_{Vi} + \sum_{j=1}^N V_i V_j Y_{ij}(X_{Si}) \sin(\theta_{ij}(X_{Si}) - \delta_i + \delta_j) = 0 \quad (3)$$

$$P_{Gi}^{min} \leq P_{Gi} \leq P_{Gi}^{max} \quad \forall i \in NG \quad (4)$$

$$Q_{Gi}^{min} \leq Q_{Gi} \leq Q_{Gi}^{max} \quad \forall i \in NG \quad (5)$$

$$V_i^{min} \leq V_i \leq V_i^{max} \quad \forall i \in N \quad (6)$$

$$|S_{Li}| \leq S_{Li}^{max} \quad \forall i \in NL \quad (7)$$

$$VCPI_i \leq 1 \quad \forall i \in N \quad (8)$$

$$|\delta_{ij}| \leq \delta_{ij}^{crit} \quad \forall i \in N \quad (9)$$

$$X_{Si}^{min} \leq X_{Si} \leq X_{Si}^{max} \quad (10)$$

$$\alpha_{Pi}^{min} \leq \alpha_{Pi} \leq \alpha_{Pi}^{max} \quad (11)$$

$$V_{Ui}^{min} \leq V_{Ui} \leq V_{Ui}^{max} \quad (12)$$

$$\alpha_{Ui}^{min} \leq \alpha_{Ui} \leq \alpha_{Ui}^{max} \quad (13)$$

$$Q_{Vi}^{min} \leq Q_{Vi} \leq Q_{Vi}^{max} \quad (14)$$

$$0 < location_k \leq NorNL \quad (15)$$

Where

$F$	objective function,
$P_{Gi}^{min}, P_{Gi}^{max}$	lower and upper limits of real power generation at bus $i$ ,
$Q_{Gi}^{min}, Q_{Gi}^{max}$	lower and upper limits of reactive power generation at bus $i$ ,
$V_i^{min}, V_i^{max}$	lower and upper limits of voltage magnitude at bus $i$ ,
$S_{Li}^{max}$	$i$ th line or transformer loading limit,
$\delta_{ij}^{crit}$	critical angle difference between bus $i$ and $j$ ,
$X_{Si}^{min}, X_{Si}^{max}$	lower and upper limits of TCSC at line $i$ ,
$\alpha_{Pi}^{min}, \alpha_{Pi}^{max}$	lower and upper limits of TCPS at line $i$ ,
$V_{Ui}^{min}, V_{Ui}^{max}$	lower and upper voltage limits of UPFC at line $i$
$\alpha_{Ui}^{min}, \alpha_{Ui}^{max}$	lower and upper angle limits of UPFC at line $i$ ,
$Q_{Vi}^{min}, Q_{Vi}^{max}$	lower and upper limits of SVC at bus $i$ ,
$N, NL$	number of buses and branches,
$NG$	number of generator buses,
$ND\_SNK$	number of load buses in a sink area,
$n_{CFK}^{max}$	maximum allowable component of FACTS type $k$ ,
$V_i, V_j$	voltage magnitudes at bus $i$ and $j$ ,
$\delta_i, \delta_j$	voltage angles of bus $i$ and $j$ ,
$P_{G1}, Q_{G1}$	real and reactive power generations at slack bus,
$P_{Gi}, Q_{Gi}$	real and reactive power generations at bus $i$ ,
$P_{Di}, Q_{Di}$	real and reactive loads at bus $i$ ,
$P_{Lossi}$	power loss at bus $i$ ,
$P_{Pi(\alpha Pk)}$	injected real power of TCPS at bus $i$ ,
$Q_{Pi(\alpha Pk)}$	injected reactive power of TCPS at bus $i$ ,
$P_{Ui(VUk, \alpha Uk)}$	injected real power of UPFC at bus $i$ ,
$Q_{Ui(VUk, \alpha Uk)}$	injected reactive power of UPFC at bus $i$ ,
$Y_{ij(XS)}, \theta_{ij(XS)}$	magnitude and angle of the $ij$ th element in bus admittance matrix with TCSC included,
$m(i)$	number of injected power from TCPS at bus $i$ ,
$n(i)$	number of injected power from UPFC at bus $i$ ,
$ SLi $	$i$ th line or transformer loading,
$VCPI_i$	voltage collapse proximity indicator at bus $i$ ,

$ \delta_{ij} $	angle difference between bus $i$ and $j$ ,
$X_{Si}$	reactance of TCSC at line $i$ ,
$\alpha_{Pi}$	phase shift angle of TCPS at line $i$ ,
$V_{Ui}, \alpha_{Ui}$	voltage magnitude and angle of UPFC at line $i$ ,
$Q_{Vi}$	injected reactive power of SVC at bus $i$ , and
$location_k$	integer value of line or bus location of FACTS type $k$ .

In this paper considers voltage collapse proximity indicator (VCPI), thermal line flow limit, and static angle stability constraint. The limits are treated as OPF constraints in (6), (7), and (8), respectively. During the optimization, inequality constraints are enforced using a penalty function in (16) and (17).

$$PF = k_p h(P_{G1}) + k_q \sum_{i=1}^{NG} h(Q_{Gi}) + k_v \sum_{i=1}^N h(V_i) + k \sum_{i=1}^{NL} h(|SLi|) + k_d \sum_{p=1}^{NL} h(|\delta_{ij}, p|) + k_{vi} \sum_{i=1}^N h(VCPI_i) \quad (16)$$

$$h(x) = \begin{cases} (x - x^{max})^2 & \text{if } x > x^{max} \\ (x - x^{min})^2 & \text{if } x < x^{min} \\ 0 & \text{if } x^{min} \leq x \leq x^{max} \end{cases} \quad (17)$$

Where

$PF$	penalty function,
$x_{min}, x_{max}$	lower and upper limits of variable $x$ ,
$k_p, k_q, k_v$	penalty coefficients for real power generation at slack bus, reactive power generation of all PV buses and slack bus, and bus voltage magnitude, respectively, and
$k_s, k_d, k_{vi}$	penalty coefficients for line loading, angle difference, and voltage stability index, respectively.

### 3. PROPOSED ALGORITHM

#### 3.1 Overview of Evolutionary Programming

Evolutionary Programming (EP), a stochastic optimization strategy, originally conceived by Lawrence J. Fogel in 1962. It is a mutation-based evolutionary algorithm applied to discrete search spaces [27]. The EP algorithm starts with random generation of initial individuals in a population and then mutation [28]. The processes after mutation are competition and selection to create new offspring from parent.

### 3.2 Overview of Tabu Search

The basic concept of tabu search as described by Glover in 1986 is “a meta-heuristic superimposed on another heuristic”. The overall approach is to avoid entrainment in cycles by forbidding or penalizing moves which take the solution, in the next iteration, to points in the solution space previously visited [29-30].

### 3.3 Overview of Particle Swarm Optimization

Particle Swarm Optimization (PSO) is developed by J. Kennedy and R. Eberhart in 1995 [31]. It is a form of swarm intelligence simulated from the behavior of a biological social system such as a flock of birds or a school of fish. The PSO provides a population-based search procedure when individuals (called particles) change their position. The position of each particle is represented in X-Y plane with its position. Each particle physically moves to the new position using velocity according to its own experience, called  $P_{best}$ , and according to the experience of a neighboring particle, called  $G_{best}$ , which made use of the best position encountered by itself and its neighbor [32-33].

### 3.4 Hybrid-Particle Swarm Optimization

Hybrid-Particle Swarm Optimization (hybrid-PSO) is an integrated approach between PSO, EP, and TS by using PSO as a main algorithm. The general flowchart of hybrid-PSO is shown in Fig. 1.

The main components of the algorithm are briefly explained as follows:

*Step 1: Generation of initial condition of each particle.* Initial searching points and velocities of each particle are usually random within the allowable range. The current searching point is set to for each particle. The best evaluated value of is set to , and the best value is stored.

*Step 2: Evaluation of searching point of each particle.* The objective function value is calculated for each particle. If the value is better than the current  $P_{best}$  of the particle, the  $P_{best}$  value is replaced by the current value. If the best value of is better than the current  $G_{best}$ ,  $G_{best}$  is replaced by the best value and the best value is stored.

*Step 3: Modification of each search point.* The current searching point of each particle is changed using conventional velocity equation of PSO in (18).

$$v_i^{k+1} = w \times v_i^k + c_1 \times rand_1 \times (P_{best_i} - s_i^k) + c_2 \times rand_2 \times (g_{best} - s_i^k) \quad (18)$$

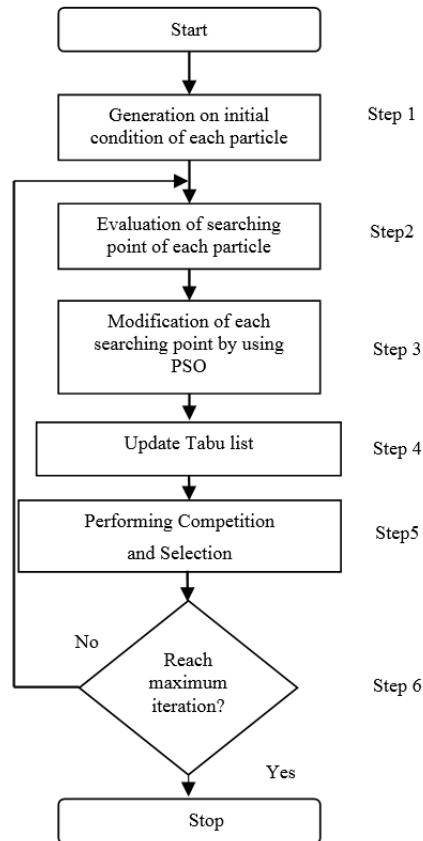

Fig. 1: A general flowchart of hybrid-PSO.

Where  $v_i^k$  velocity of particle  $i$ th at iterations,  
 $w$  weight function,  
 $c_1$  and  $c_2$  weighting coefficients both equal to 2,  
 $rand_1$  and  $rand_2$  random number between 0 and 1,  
 $s_i^k$  current positions of particle  $i$ th at iteration  $k$ ,  
 $P_{best_i}$  best position of particle  $i$ th up to the current iteration, and  
 $g_{best}$  best overall position found by the particles up to the current iteration.

Weight function is given by (19):

$$w = w_{max} - \frac{w_{max} - w_{min}}{iter_{max}} \times iter \quad (19)$$

Where  $w_{max}$  initial weight equal to 0.9,  
 $w_{min}$  final weight equal to 0.4,  
 $iter_{max}$  maximum iteration number, and  
 $iter$  current iteration number.

*Step 4: Tabu list.* This may be viewed as a “meta-heuristic” superimposed on another heuristic method. It is designed to jump local optimal and prevent the cycling movement. It stores movement of solution and forbids backtracking to previous movement [27, 28].

*Step 5: Competition and selection.* This utilization technique is a tournament scheme, which can be computed by using general competition and selection method of EP [29].

*Step 6: Checking the exit condition.* The current iteration number reaches the pre-determined maximum iteration number, then exits. Otherwise the process proceeds to step 2.

### 3.5 Optimal Power Flow with FACTS controllers by Hybrid Particle Swarm Optimization

Hybrid-PSO is used to determine the optimal allocation of multi-type FACTS controllers to maximize the objective function. The proposed method is shown in Fig. 2, which can be described as follows:

*Step 1: Solving base case power flow.* This step solves base case power flow between selection source and sink areas. A full ac Newton-Raphson (NR) power flow analysis is used.

*Step 2: Initialize particles contain all variables.* The  $i$ th particle in a population is represented by a trial solution vector as (20) and (21).

$$V_p^T = [P_{Gp}, V_{Gp}, P_{Dq}, Loc_k] \quad (20)$$

$$Loc_k = [n_{CFk}, location_k, parameter_k] \quad (21)$$

Where

$V_p^T$	trial solution vector of the $p$ th particle,
$V_{Gi}$	voltage magnitude of generator at bus $i$ including slack bus,
$Loc_k$	allocation vector of FACTS controller type $k$ ,
$n_{CFk}$	number of FACTS components, equal 1,
$location_k$	line or bus location of FACTS type $k$ ,
$parameter_k$	parameter settings of FACTS type $k$

*Step 3: Solving power flow.* This step solves power flow between selection source and sink areas. A full ac Newton-Raphson (NR) power flow analysis is used by including FACTS controllers static model and compute the objective function. Then keep  $V_i^T$  of the best objective value as  $Pbest$  and  $Gbest$ . The objec-

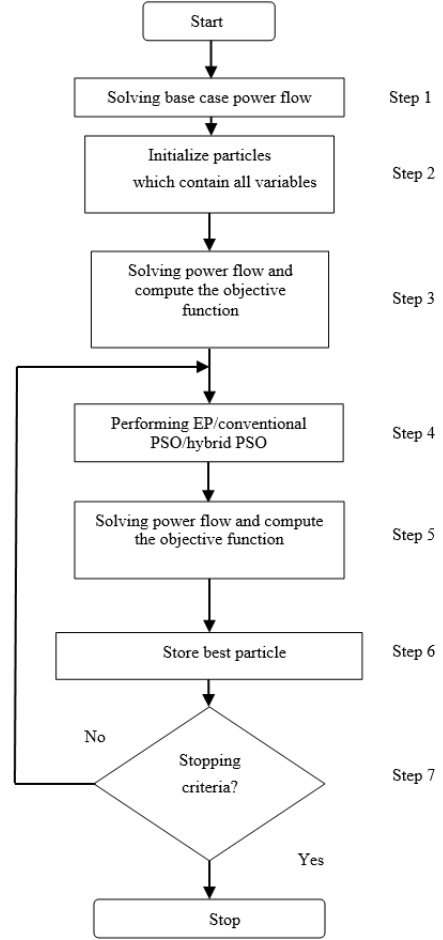

**Fig. 2:** A general flowchart of Proposed Algorithm.

tive function in (1) is taken as the fitness function of the hybrid-PSO approach.

*Step 4: Performing hybrid-PSO algorithm for new searching point.* All variables in (20) and (21) are modified to new searching point using the hybrid-PSO algorithm.

*Step 5: Solving power flow.* This step solves power flow between selection source and sink areas. A full ac Newton-Raphson (NR) power flow analysis is used by including FACTS controllers static model and compute the objective function. Then keep the  $V_i^T$  of best objective value as  $Pbest$ . If new objective value is better than the previous value then  $V_i^T$  is stored as  $Gbest$ . The fitness values are evaluated, too.

*Step 6: The best particle is stored by decision of the best objective function.*

*Step 7: Stopping criteria.* Repeat step 4-6 until there is no improvement of the best fitness within 20 iterations or the maximum number of iterations is reached.

#### 4. CASE STUDY AND EXPERIMENTAL RESULT

The IEEE RTS 24-bus system, IEEE30-bus system, and IEEE-118 bus system were used as test systems. In the simulations, the reactance limit of TCSC in p.u. was  $0 \leq X_{si} \leq 60\%$  of line reactance, phase shifting angle limit of TCPS was  $-\frac{\pi}{4} \leq X_{si} \leq \frac{\pi}{4}$  radian, angle limit of UPFC was  $-\pi \leq \alpha_{U_i} \leq \pi$  radian, voltage limit of UPFC was  $0 \leq V_{U_i} \leq 0.1$  p.u., and reactive power injection limit of SVC was  $0 \leq Q_{V_i} \leq 10$  MVAR. Loads were modeled as constant power factor loads. The particle group sizes of conventional PSO and hybrid-PSO were set to 30. The population size of EP was set to 30. The maximum iteration numbers of EP, conventional PSO, and hybrid-PSO were set to 400.

##### 4.1 The IEEE RTS 24-bus system

The IEEE RTS 24-bus system consisted of 10 generating plants, 24 load buses, and 37 lines shown in Fig. 3 was used as the first test system. Bus 13 was set as swing bus. Base case TTC of IEEE RTS 24-bus system equaled 1131.00 MW.

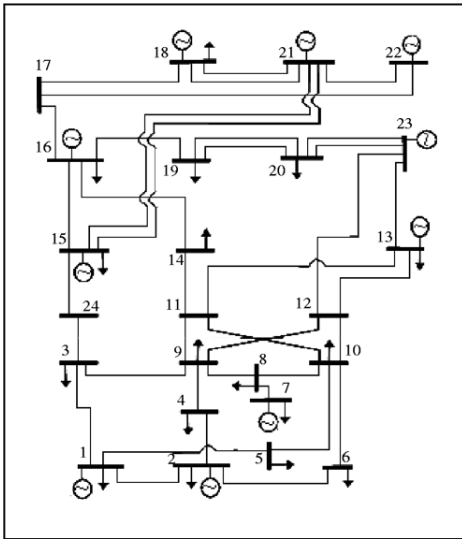

**Fig.3:** Diagram of IEEE RTS 24-bus system.

From Table 1, hybrid-PSO gave higher TTC than EP and conventional PSO. The best, the average and the worst TTC obtained from hybrid-PSO are 2317.98 MW, 2232.91 MW, and 2016.31 MW, respectively. All of the best, the average, and the worst TTC from hybrid-PSO were also better than EP and conventional PSO. In addition, results from this test system hybrid-PSO used less CPU time than conventional PSO. The best optimal allocation of multi-type FACTS controllers from hybrid-PSO was represented in Table 2.

**Table 1:** TTC Results and CPU Time from EP, conventional PSO, and hybrid-PSO on IEEE RTS 24-bus system.

Method \ TTC (MW)	EP	conventional PSD	hybrid-PSO
Best	2164.71	2255.89	2317.98
Average	2051.30	2080.31	2232.91
Worst	1994.52	1932.37	2016.31
Standard deviation	58.72	83.48	79.70
Average CPU time (min)	1.67	2.71	2.56

**Table 2:** The optimal allocation of multi-type FACTS controllers from hybrid-PSO of IEEE RTS 24-bus system.

Type of FACTS Controller	TCSC	TCPS	UPFC		SVC
Parameter of FACTS Controller	$X_s$ (p.u.)	$\alpha_p$ (rad)	$\alpha_u$ (rad)	$V_u$ (p.u.)	$Q_v$ (MVAR)
	0.0231	0.0012	-0.0011	0.0056	5.663
Location	Line 25	Line 24	Line 10		Bus 24

##### 4.2 The IEEE 30-bus system

The IEEE 30-bus system consisted of 6 generating plants, 30 load buses, and 41 lines shown in Fig. 4 was used as the second test system. Bus 1 was set as swing bus. Base case TTC of IEEE 30-bus system equaled 164.30 MW.

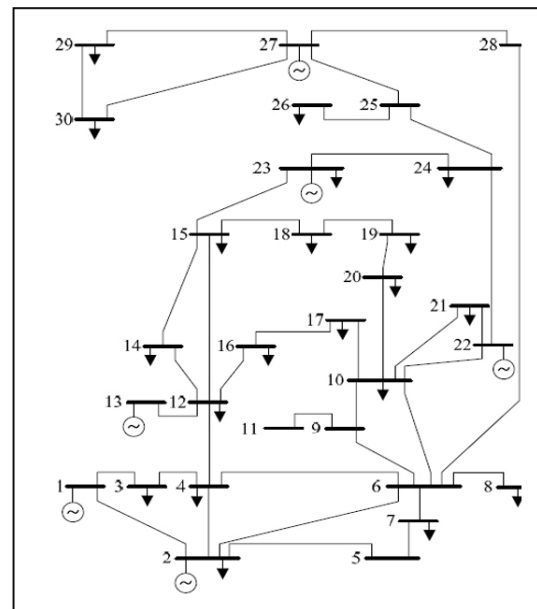

**Fig.4:** Diagram of IEEE 30-bus system.

From Table 3, TTC results from hybrid-PSO were higher than TTC from EP and conventional PSO. The best, the average and the worst TTC obtained from hybrid-PSO were 361.52 MW, 284.01 MW, and 263.87 MW, respectively. In this test system, hybrid-PSO used the highest CPU time. It could be indi-

cated that hybrid-PSO can step over the local optimal and use more iterations and CPU times for convergence to global optimal. The allocation of multi-type FACTS controllers from hybrid- PSO was represented in Table 4.

**Table 3:** *TTC Results and CPU Time from EP, conventional PSO, and hybrid-PSO on IEEE 30-bus system.*

TTC (MW) \ Method	EP	conventional PSD	hybrid-PSO
Best	224.61	228.65	361.52
Average	221.62	211.13	284.01
Worst	203.79	202.49	263.87
Standard deviation	10.73	7.80	21.52
Average CPU time (min)	6.47	2.17	8.86

**Table 4:** *The optimal allocation of multi-type FACTS controllers from hybrid-PSO of IEEE 30-bus system.*

Type of FACTS Controller	TCSC	TCPS	UPFC		SVC
Parameter of FACTS Controller	$X_s$ (p.u)	$\alpha_p$ (rad)	$\alpha_u$ (rad)	$V_u$ (p.u.)	$Q_v$ (MVAR)
	0.0231	0.0012	-0.0011	0.0056	5.663
Location	Line 29	Line 25	Line 27		Bus 24

### 4.3 The IEEE 118-bus system

The IEEE 18-bus system consisted of 54 generating plants, 64 load buses, and 186 lines shown in Fig. 5 was used as the third test system. Bus 1 was set as swing bus. Base case TTC of IEEE 118-bus system equaled 1433.00 MW.

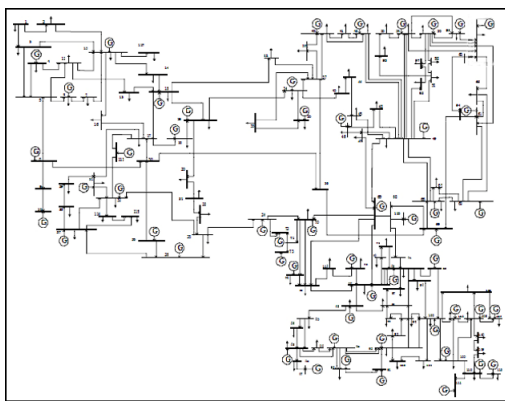

**Fig.5:** *Diagram of IEEE 118-bus system.*

From Table 5, TTC results from hybrid-PSO showed higher TTC than those from EP and conventional PSO. The best, the average and the worst TTC obtained from hybrid-PSO are 3410.78 MW, 3174.95 MW, and 2906.22 MW, respectively. It could be indicated that hybrid-PSO can step over from local op-

**Table 5:** *TTC Results and CPU Time from EP, conventional PSO, and hybrid-PSO on IEEE 118-bus system.*

TTC (MW) \ Method	EP	conventional PSD	hybrid-PSO
Best	2767.60	2979.08	3410.78
Average	2529.94	2832.75	3174.95
Worst	2373.30	2656.07	2906.22
Standard deviation	126.86	94.34	132.65
Average CPU time (min)	40.29	16.25	16.72

**Table 6:** *The optimal allocation of multi-type FACTS controllers from hybrid-PSO of IEEE 118-bus system.*

Type of FACTS Controller	TCSC	TCPS	UPFC		SVC
Parameter of FACTS Controller	$X_s$ (p.u)	$\alpha_p$ (rad)	$\alpha_u$ (rad)	$V_u$ (p.u.)	$Q_v$ (MVAR)
	0.0553	0.0430	0.0581	0.0693	0.0193
Location	Line 71	Line 144	Line 11		Bus 18

timal by TS and uses less CPU times than EP by conventional PSO mechanism. In additional, competition and selection strategy gave the strong parents to create new offspring particles for convergence to global optimal. The allocation of multi-type FACTS controllers from hybrid-PSO was represented in Table 6.

## 5. CONCLUSIONS AND FUTURE WORK

In this paper, hybrid-PSO was used to determine the optimal allocations of multi-type FACTS controllers. The hybrid-PSO used the selection mechanism of EP and updating strategy based on TS to step over from the local solutions. These advantages of hybrid-PSO can be used to calculate TTC, especially in large and complicate test system. The hybrid-PSO resulted in the effectiveness to improve the searching for optimal location and the operating points of multi-type FACTS controllers. The overall results from the test systems indicated that the hybrid-PSO can effectively and successfully enhance the higher TTC more than those from EP and conventional PSO. In addition, the hybrid PSO can create no different convergence in IEEE 24-bus and IEEE 30-bus test system. Faster and better convergence can also be created by the hybrid PSO, compared to EP and conventional PSO in IEEE 118-bus test system. These can specify that the hybrid PSO use less sufficiency CPU time than EP and conventional PSO. Therefore, the installation of FACTS controllers with optimal allocation using hybrid-PSO are worthwhile and beneficial for the decision making and further expansion plans.

## ACKNOWLEDGEMENT

This work was supported in part by the Energy Policy and Planning Office (EPPO), Ministry of Energy, Thailand and Thailand and Academic Research Division, Thailand Research Fund (TRF).

## References

- [1] Y. H. Song and Y. H. Johns, *Flexible AC Transmission System (FACTS)*, IEE Power and Energy Series 30, 1999.
- [2] M. A. Abdel-Moamen and N. P. Padhy, "Optimal power flow incorporating FACTS devices-bibliography and survey," *IEEE PES Transmission and Distribution Conference and Exposition 2003*, vol. 2, Sep. 2003.
- [3] IEEE Power Engineering Society, "FACTS Overview," Cigre 95 TP108, 1995.
- [4] N. G. Hingorani and L. Gyugyi, *Understanding FACTS: Concepts and Technology of Flexible AC Transmission Systems*, New York, John Wiley & Sons, 1999.
- [5] IEEE Power Engineering Society, "FACTS Applications," Dec 1995.
- [6] A. Parameeswaran, A. Sarma, H. Garcia-Molina, N. Polyzotis, FACTS Terms & Definitions Task Force of the FACTS Working Group of the DC and FACTS Subcommittee, "Proposed Terms and Definitions for Flexible AC Transmission System (FACTS)," *IEEE Transactions on Power Delivery*, vol. 12, no. 4, Oct. 1997.
- [7] H. Ren, D. Watts, Z. Mi, and J. Lu, "A review of FACTS' practical Consideration and Economic Evaluation," *Power and Energy Engineering Conference 2009, Asia-Pacific*, 2009.
- [8] T. S. Chung and G. Shaoyun, "Optimal power flow incorporating FACTS devices and power flow control constraints," *International Conference Power System Technology*, Aug. 1998
- [9] G. C. Ejebe, J. G. Waight, S. N. Manuel, and W. F. Tinney, "Fast calculation of linear available transfer capability," *IEEE Transactions on Power Systems*, vol. 15, no. 3, Aug. 2000.
- [10] S. Gerbex, R. Cherkaoui, and A. J. Germond, "Optimal location of multi-type FACTS devices in a power system by means of genetic algorithms," *IEEE Transaction Power System*, vol. 16, no. 3, pp. 537-544, Aug. 2001.
- [11] S. Chansareewittaya and P. Jirapong, "Power transfer capability enhancement with Optimal Number of FACTS Controllers using hybrid TSSA," *IEEE SouthEastCon2012*, Orlando, Florida, USA, Mar. 2012.
- [12] L. J. Fogel, A. J. Owens, and M. J. Walsh, *Artificial Intelligence Thorough Simulated Evolution*, John Wiley & Sons, Ltd, Chichester, U.K., 1966.
- [13] F. Glover and M. Laguna, *Handbook of Applied Optimization, chapter Tabu Search*, Oxford Academic Press, 1980.
- [14] D. E. Goldberg, *Genetic Algorithm in Search: Optimization and Machine Learning*, Addison Wesley Publishing Company, USA, 1989.
- [15] M. A. Abido, "Optimal power flow using particle swarm optimization," *International Journal of Electrical Power & Energy Systems*, vol. 24, Issue 7, pp. 563-571, Oct. 2002.
- [16] M. R. AlRashidi and M. E. El-Hawary, "Applications of computational intelligence techniques for solving the revived optimal power flow problem," *Electric Power Systems Research*, vol. 79, issue 4, pp. 694-702, Apr. 2009.
- [17] W. Ongsakul and P. Jirapong, "Optimal allocation of FACTS devices to enhance total transfer capability using evolutionary programming," *International Symposium on Circuits and Systems*, Japan, 23-26 May, vol. 5, 2005.
- [18] M. A. Abido, "Optimal Power Flow Using Tabu Search Algorithm," *Electric Power Components and Systems*, vol. 30, issue 5, pp. 469-483S, 2002.
- [19] S. Panda and N. P. Padhy, "Comparison of particle swarm optimization and genetic algorithm for FACTS-based controller design," *Applied Soft Computing*, vol. 8, issue 4, pp. 1418-1427, Sep. 2008.
- [20] S. Chansareewittaya and P. Jirapong, "Power Transfer Capability enhancement with multi-type FACTS controller Using Particle Swarm Optimization", *IEEE TENCON2010*, Fukuoka, Japan, Nov. 2010.
- [21] S. A. Jumaat, I. Musirin, M. M. Othman, H. Mokhlis, "Placement and sizing of thyristor controlled series compensator using PSO based technique for loss minimization," *2012 IEEE International Power Engineering and Optimization Conference*, PEOCO 2012 - Conference Proceedings, Malacca, Malaysia, Jun 2012.
- [22] A. J. Siti, M. Ismail, M. O. Muhammad, H. Mokhlis, "Applications of PSO technique to optimal location and sizing of static var compensator," *2012 IEEE Symposium on Computers and Informatics*, ISCI 2012, Penang, Malaysia, Mar 2012.
- [23] S. A. Jumaat, I. Musirin, M. M. Othman, H. Mokhlis, "PSO based technique for loss minimization considering voltage profile and cost function," *2011 5th International Power Engineering and Optimization Conference*, PEOCO 2011 - Program and Abstracts, Selengor, Malaysia, Jun 2011.
- [24] A. T. Al-Awami, Y. L. Abdel-Magid, and M. A. Abido, "A particle-swarm-based approach of power system stability enhancement with unified power flow controller," *International Journal of Electrical Power & Energy Systems*, vol. 29, Issue 3, pp. 251-259, Mar. 2007.
- [25] N. W. Oo, "A comparison study on particle swarm and evolutionary particle swarm optimization using capacitor placement problem,"



- 2nd IEEE international Conference on Power and Energy*, Johor Baharu, Malaysia, Dec. 2008.
- [26] P. Bhasaputra and W. Ongsakul, "Optimal power flow with multitype FACTS devices by hybrid TS/SA approach," *IEEE ICIT'02*, Bangkok, Thailand, 2002.
- [27] K. Deb, *Multi-Objective Optimization using Evolutionary Algorithms*, John Wiley and Sons, Inc., New York, 2004, ch4
- [28] S. Chansareewittaya and P. Jirapong, "Power Transfer Capability enhancement with Optimal Maximum Number of FACTS Controllers using Evolutionary Programming," *IEEE IECON2011 Conference on IEEE Industrial Electronics Society*, Melbourne, Australia, Nov. 2011.
- [29] F. Glover, "Tabu Search, Part I," *ORSA Journal on Computing*, vol. 1, no. 3, pp. 190-206, Summer, 1989.
- [30] F. Glover, "Tabu Search, Part II," *ORSA Journal on Computing*, vol. 2, no. 1, pp. 4-32, Winter, 1990.
- [31] J. Kennedy and R. Eberhart, "Particle swarm optimization," *IEEE International Conference of Neural Networks*, vol.4, pp. 1942-1948., 1995.
- [32] L. L. Lai, *Intelligent System Applications in Power Engineering: Evolutionary Programming and Neural Networks*, John Wiley & Sons, 1998.
- [33] K. Y. Lee and A. E. Mohamed, *Modern Heuristics Optimization Techniques*, New York, John Wiley & Sons, 2008.



**Suppakarn Chansareewittaya** received his B.Eng degree in Electrical Engineering from King Mongkut's Institute of Technology Ladkrabang, Bangkok, Thailand, in 2001 and M.Eng degree in Electrical Engineering from Chiang Mai University, Chiangmai, Thailand, in 2007. He has joined the membership of IEEE since he was a master student. Now he is a Ph.D. student in Electrical Engineering, Department of Electrical Engineering, Faculty of Engineering, Chiang Mai University, Chiang Mai, Thailand. His research interests are heuristic methods and electrical engineering.

Engineering, Faculty of Engineering, Chiang Mai University, Chiang Mai, Thailand. His research interests are heuristic methods and electrical engineering.



**Peerapol Jirapong** received his B.Eng degree with 2nd class honor in Electrical Engineering from King Mongkut's Institute of Technology Ladkrabang, Bangkok, Thailand, in 1997, M.Eng degree and D.Eng degree in Electrical Engineering from Asian Institute of Technology, Pathumthani, Thailand, in 2000 and 2006, respectively. Now he is an assistant professor of Department of Electrical Engineering, Faculty of Engineering, Chiang Mai University, Chiang Mai, Thailand. His research interests are high voltage engineering and electrical power engineering.

ing, Chiang Mai University, Chiang Mai, Thailand. His research interests are high voltage engineering and electrical power engineering.