

# Optimal Control of Automatic Manipulator for Elimination of Galvanic Line Load Oscillation

Siarhei Outsou<sup>1</sup>, Anton Rassõlkin<sup>2,3\*</sup>, Toomas Vaimann<sup>2,3</sup>, Galina Demidova<sup>3</sup>, Viktor Saroka<sup>1</sup>, Dzmitry Karpovich<sup>1</sup>, Ants Kallaste<sup>2</sup>

<sup>1</sup> Department of Automation of Production Processes and Electrical Engineering, Faculty of Chemical Technology and Technique, Belarussian State Technological University, 220006 Minsk, 13a Sverdlova str., Belarus

<sup>2</sup> Department of Electrical Power Engineering and Mechatronics, Tallinn University of Technology, 19086 Tallinn, 5 Ehitajate street, Estonia

<sup>3</sup> Faculty of Control Systems and Robotics, ITMO University, 197101 St. Petersburg, 49 Kronverksky Pr., Russia

\* Corresponding author, e-mail: [anton.rassolkin@ttu.ee](mailto:anton.rassolkin@ttu.ee)

Received: 09 March 2020, Accepted: 11 June 2020, Published online: 14 January 2021

## Abstract

This paper provides an analysis of the current state-of-the-art technologies in the field of auto-operators used in production during the electroplating process. General schemes of operations are presented, benefits and drawbacks of each scheme are discussed. The paper discusses an increase in the operating efficiency of the auto-operator in transient conditions (braking and acceleration) by reducing suspension oscillations and provides an example of a similar problem from other industries. In addition to the classification of the auto-operators, three main ways and control methods of the auto-operator of a galvanic line are presented. The main ways of eliminating oscillations during the movement of the auto-operator, as well as the rationale for the choice of adaptive (optimal) control, based on and comparing the basic control algorithms of the robot manipulator, are discussed. The comparative analysis of algorithms used to determine the optimal control has been carried out. Application field of each optimal control method described, moreover advantages and disadvantages as well as implementation methods described. Bellman dynamic programming method was chosen to eliminate oscillations of the suspension with details during the auto-operator transient conditions, the chosen method takes into account all necessary conditions to achieve the desired result.

## Keywords

optimal control, optimization methods, automatic programming

## 1 Introduction

To proceed with the further assembly of technical devices, nowadays industry separates parts of the products needed to be galvanized into additional processing in galvanic lines. In the most common method of galvanization, the parts are submerged in a bath of liquid cover material. The galvanic line is intended for the technological process of applying various coatings on iron or steel. The process, which uses an electric current to reduce dissolved metal cations, is called electroplating. Applying of electroplating gives the parts an additional surface property, such as abrasion and wear resistance, corrosion protection, lubricity, aesthetic qualities.

During the galvanization process, parts have various technological stages – anodizing, degreasing, painting, etc. The duration of each process stage is different from the

other and depends on the quantity and quality of the products themselves. Processing at the galvanic line may be separated into three main groups [1]:

1. Pre-processing, at this level various oils, paints, and other pollution material are removed.
2. Coating, the main stage, at this stage details are getting new properties.
3. Post-processing, at this stage details are washed from residues of electrolytes and dried.

By automation integration, galvanic lines could be divided into two types [2]:

1. Automatic/semi-automatic lines, this type of galvanic line uses a robot-manipulator (with automatic or manual control system) for moving details.

2. Mechanical lines, this type of galvanic line uses various manual devices for moving details operated manually by staff.

The first part of the paper deal with the introduction and short descriptions pros and cons galvanization process. Section 2 of this paper presents a classification of galvanic lines used in the industry and auto-operators, including the control strategies. Section 3 presents an overview of control algorithms to eliminate undesirable oscillations, which occur during the transients. The Section 4 discusses optimal control method selection. Sections 5 and 6 discuss the modelling and simulation of selected optimal control method respectively.

## 2 Classification of galvanic lines and auto-operators

Coating stage of galvanic lines includes few stages (baths) for increasing the quality of processing. Fig. 1 shows four main types of galvanic lines used in the industry, with the various allocation of the line rows [3]. Movement of the

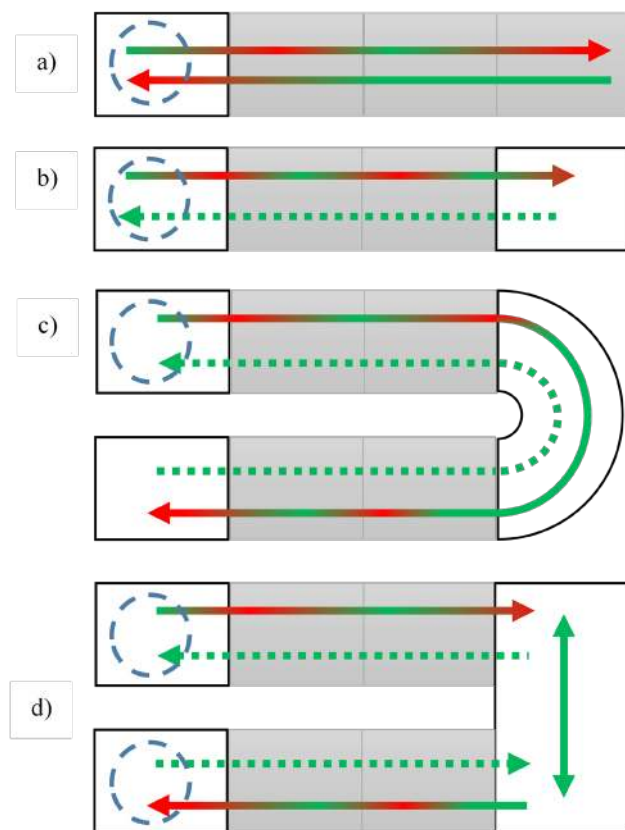

**Fig. 1** Types of galvanic lines, where (a): linear galvanic line with the same initial and final position of auto-operator; (b): linear galvanic line with the different initial and final position of auto-operator; (c): two-row oval galvanic line; (d): two-row square galvanic line.

auto-operator is shown with arrows, flat lines for the main movements of auto-operator, with red, the areas of high oscillation are highlighted, and dotted are the ones for an empty run.

1. Linear galvanic line with the same initial and final position of auto-operator. This type of galvanic line has one or two auto-operators. The first one is used for preparatory operations at the beginning of the line, second is used for final operations at the end of the line. Typically, only one robot-manipulator is used for such type of galvanic lines. The linear line is used for small production.
2. Linear galvanic line with the different initial and final position of auto-operator. This type of galvanic line is used, when the manufacturer has subdivisions with the same operations and common conveyor; or constantly moves the robot-manipulator for moving details between different technological positions. Commonly, on the manufacture set, few small subdivisions can be found in the total galvanic line in the sequence of operations. Similar to the linear galvanic line with the same initial and final position of auto-operator, this type of galvanic line is used for small production.
3. Two-row oval galvanic lines are used, when initial and final positions of the auto-operator are located in different places of manufacture. Usually, two or more auto-operators operate at the galvanic line. The main drawback of the two-row oval line is the complicated structure of trails of the robot-manipulator at the end of the first row that displaces details into the second row of the line. The two-row oval galvanic line is used for mass production.
4. Application of the two-row square galvanic line is similar to the two-row oval galvanic line, but it does not have displacement drawback, while it is equipped with the common galvanic bath that connects both rows of the line. Similarly, to the previous one, it is used for mass production.

The performance of galvanic manufacture depends not only on the structure of the galvanic line but also on the type of auto-operator, which operates on the line [3]. An auto-operator is a robotic arm that is designed to move parts during the processing along the galvanic line and to work with special tools like hangers, cathode rods, and drum containers [4–6]. Modern industrial robots are complex technical systems that are used for various technological operations associated with the movement of goods,

parts, etc. [7–9]. As shown in [10], the energy consumption of an industrial robot depends on the characteristics of its movement. Different trajectories mean the involvement of different degrees of freedom, which in turn means operating different electric motors of the robot.

There are three control modes of galvanic line operator: manual, semi-automatic, and automatic control.

Manual control mode is used for adjusting the robot-manipulator operation, or in case of emergency control of the auto-operator. With manual control, the movement of the auto operator is carried out from the control panel and auto-operator speed is minimized, to reduce the risks of emergency. The movement of the auto-operator occurs until the operator stops the robot by pressing buttons on the control panel or a malfunction occurs. In this control mode, limit switches are installed for safety reasons. The main disadvantage of manual control mode is the limited productivity of a robot due to the psycho-physical factors of a human operator (ex. fatigue) [11–14]. With manual control mode, switching to other modes is not possible until the system is in the main operating position.

Semi-automatic control mode is used for changing conditions of the technological process, for example, the order of processing parts, the exposure time in bathrooms, etc. A control panel is also used in the case of semi-automatic control mode; however, the main difference is that the human operator selects the position that the auto-operator needs to reach. Trajectory matching is usually done automatically by the implementation of optical sensors. Similarly to the manual control mode, productivity is limited due to the lack of consideration of the disturbances that occur at the endpoints of the robot-manipulator movement [11–13].

An automatic control mode of the auto-operator is represented by the cyclogram of the electroplating process. Cyclogram is a moving path of an auto-operator serving to project its motion, an example of a cyclogram is shown in Fig. 2. Each cyclogram includes: lifting, moving to a given technological position, and lowering parts into the bath.

In the automatic control mode, stopping at the end position is also done by optical sensors. Improvement of productivity of the robot-manipulator is possible, however, the right algorithm for eliminating disturbances should be selected [11–13].

Auto-operators are divided into three types, in accordance with the installation method of the robot arm: telpher, console, and portal.

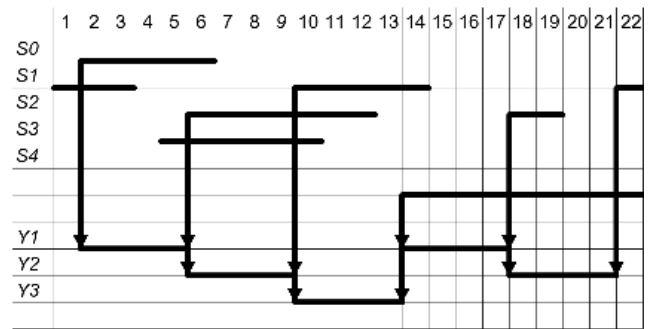

**Fig. 2** Example of the cyclogram used in automatic control mode of galvanic line, where: S0: system activation; S1: traverse auto-operator in the upper position; S2: traverse auto-operator in the lower position; S3: suspension with details grasped by the auto-operator; S4: auto-operator over a given technological position and output signals Y1: lowering the traverse of the auto-operator; Y2: raising the traverse of the auto-operator; Y3: move the auto operator.

### 2.1 Telpher type auto-operator

A telpher type robot arm is designed to work with cathode rods or drum containers on which workpieces are located. The route of the operator is fixed above the galvanic baths on the guide rail, which allows the maximum use of the manufacturing area. A sketch of a telpher robot-manipulator is presented on Fig. 3.

Motor for the horizontal movement is used for transferring frame of the telpher auto-operator. Motor for the vertical movement is used for lowering or raising the traverse of the robot-manipulator. Traverse is used to grasping the drum container. That type of auto-operator has medium load capacity, up to 250 kg [5, 8].

The telpher auto-operator has two operation modes. Manual mode is a standard for telpher robot-manipulator, in this mode, a control panel is used, dedicated buttons

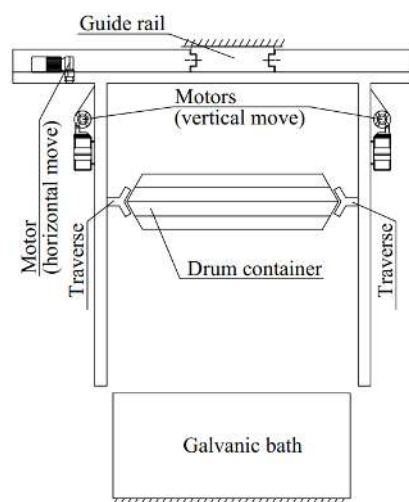

**Fig. 3** Sketch of the telpher robot-manipulator.

correspond to a specific movement of auto-operator and end positions are determined by the sensors (optical, mechanical, inductive, etc. end-switches). Adjustment mode is used to set up a control program of auto-operator by holding the buttons on the control panel, in this mode the robot-manipulator moves with low speed. In both modes, acceleration and deceleration ramps are provided by the frequency converters, which reduces the operating time of the auto-operator [13–15].

### 2.2 Console type auto-operator

Console type auto-operator is an L-shaped floor mounted rack, with guide rail installed only on one side of the galvanic line. Due to design, such type of auto-operator is used only for low-mass parts, up to 100 kg [6]. Sketch of the console robot-manipulator is presented in Fig. 4. Cupboard with the motor-drive system is used for the horizontal movement frame of the console and vertical movement of the traverses system, the system is used for lowering/raising the cathode rod.

The console auto-operator has two work modes. First, manual mode is used for tuning of console robot-manipulator. In this mode, the control of the robot-manipulator is carried out by a control panel, which is usually located close to the auto-operator on flexible cable, and the control panel is equipped with direction buttons. The second mode is elevator mode. It is a semi-automatic operation mode of the console robot-manipulator. Moving of

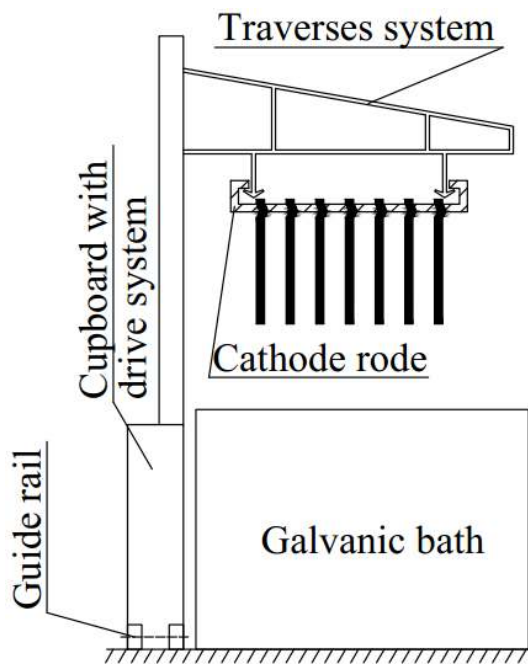

Fig. 4 Sketch of the console robot-manipulator.

auto-operator is carried out by a common control panel by pressing buttons, which is corresponding to a certain technological position. Speed control of the console auto-operator is carried out by a motor-drive system [5, 13, 15].

### 2.3 Portal type auto-operator

Sketch of the portal robot-manipulator is represented in Fig. 5. This type of auto-operator is designed for heavy loads, up to 400 kg [6]. The track of the robotic arm is installed on the floor on both sides of the galvanic line, at the same level with baths. Motor for the horizontal movement is used to transfer the frame of portal auto-operator, vertical move motor for lowering or raising traverse of robot-manipulator. Traverse is used for grasping the drum container. The robotic arm works with special attachments that have protrusions, which the traverses engage [5, 13, 15]. One more advantage of portal type auto-operator is easy maintenance and rigid structure, which allows the use of this type of robot with various types of control, which will be described below.

The portal auto-operator has three work modes: manual, elevator, and automatic. Manual and elevator modes are similar to the console type auto-operator. Automatic mode uses to control the system equipped with sensors, installed along the entire galvanic line. In automatic mode, control signals from the manual control buttons are ignored, the auto-operator moves from any position to the position given to by the program of the technological process,

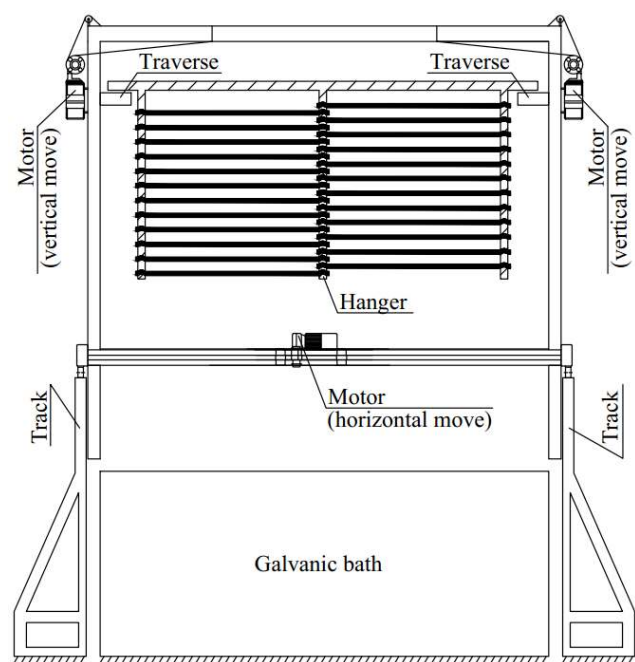

Fig. 5 Sketch of the portal robot-manipulator.

vertical movement occurs after stopping the auto-operator over the galvanic bath from the upper position to the lower position (lowering) and vice versa (raising).

### 2.4 Main challenges in auto-operators control

A comparison of auto-operators is presented in Table 1. The portal auto-operator has the greatest capacity among the presented robot-manipulators. Moreover, this type of auto-operator has more operating modes than telfher or console types. It is also worth noting, that the latter type of auto-operators works with special attachments, while the telfher and console auto-operators work with cathode rods and drum containers.

Transient processes of any type of auto-operator are non-linear, during acceleration or braking, the hanger with its subcomponents has oscillations. The oscillations lead to the next consequences: additional load on the drive elements robot-manipulator is increasing; safety the technological process and productivity of manufacture are reducing. Oscillations may hinder the accuracy of hangers setting over a galvanic bath. This applies especially to very long and heavy workpieces, oscillating movement of the load can introduce uncertainty into the program automatic operation of the automatic manipulator. Optimal control of the auto-operator of galvanic lines is required for minimization of undesirable parameters (hanger oscillations, electrodynamic loads on the motor, etc.) and maximization of the desired properties of the transient process (speed, lower power consumption, etc.).

### 3 Auto-operator control algorithms

The productivity of the auto-operator of galvanic line rises with rising the speed, but it leads to undesirable oscillations of a hanger, which can be a reason of technological process interruption. The oscillations of hanger that occur during transient modes of the automatic manipulator are the cause of its non-uniform motion and additional load on the drive elements.

Oscillations lead to reduced position accuracy, while the hanger is at a given position over the corresponding

bath. That is more significant for large and heavy machined parts. The oscillation character of the robot-manipulator movement may introduce uncertainty in the program of automated operation of the robot manipulator. Therefore, the determination of the optimal control algorithm of the auto-operator movement, when the hanger oscillations are eliminated, until the full stop, is necessary. This state allows accelerating the robot-manipulator according to any controlling law, while the hanger oscillations persist during steady motion. The literature review shows, that eliminating the oscillations during the transitional modes of the robot-manipulator is also necessary for other technical processes [16–21]. The following control algorithms are used to eliminate the oscillations [22–25]:

- fuzzy logic;
- PID-control;
- adaptive (optimal) control.

#### 3.1 Fuzzy logic

Fuzzy logic is a control algorithm that uses state variables of input signals and generates output signals based on the information received, taking into account its rate of change [26]. Fuzzy logic is significantly different from the usual discrete logic (cyclogram) since output signals can take not only two values, but a whole set [23].

Any control system based on fuzzy logic can be represented by three components: input, rule-based controller, and output. The input variables of the control system are primary variables, and they are converted into a fuzzy set, consisting of input values and membership functions, which describe the state of the primary variables [27]. The controller performs the processing of the obtained values based on the knowledge base about the operation of a particular system in the environment embedded in it and generates output crisp signals. Fuzzy logic is used in the next cases: non-linear control of technical processes [23, 28, 29]; research of data [30–32]; self-learning systems [33, 34] and etc.

The main advantage of fuzzy logic is the similarity to human beings' logic. Moreover, fuzzy logic helps a control system to overcome sudden change object parameters with small overshooting. The control system with fuzzy logic makes decisions based on impacts on the object, which leads to desirable results [35]. According to [36–38] main drawbacks of the fuzzy logic are impossible mathematical analysis of this system; too much value of input parameters; absence of a standard for the method synthesis; a high computational burden. Fuzzy logic for the control system of the auto-operator for a galvanic line is particularly used in manual control mode, which is not optimal.

**Table 1** Comparison of basic characteristics of auto-operators types

Type of auto-operator	Characteristics		
	Carrying load, kg	Modes of work	Types of additional devices
Telfher	250	2	cathode rods or drum containers
Console	100	2	cathode rods
Portal	400	3	special attachments that have protrusions



### 3.2 PID-control

Traditional fixed-gain Proportional-Integral (PI) and Proportional-Integral-Derivative (PID) controllers are very sensitive to parameter variations and load disturbances [39]. Control systems with standard PID controllers are widely used in different areas of manufacturing [40–42], but simplified to PI-controllers [43] due to simple structure and accessible calculation of regulator coefficients. The proportional gain determines are used to accelerate the transition process, as well as to counter the deviation of the controlled variable. However, the proportional gain cannot bypass the static error, which is equal to the deviation of the controlled variable from the specified value of the output signal [44]. The integral gain is used to eliminate the static error, if there are no disturbances affecting the system, at the end of the transient controlled variable will become equal to the reference signal. However, wrongly calculated integral gain causes self-oscillations in the system [44]. The derivative gain prevents the deviations of the controlled variable due to the occurrence of external influences on the system as delay, nonlinearity, etc [44].

The main challenge in the use of PID controlled systems is the lack of accurate knowledge about the object of regulation. It is often difficult to develop an accurate system mathematical model due to unknown load variation, unknown and unavoidable parameter variations due to saturation, temperature variations, and system disturbances. [39] These conditions are reasons to appear nonlinearities of the system in the tuning and operation of the PID controller, and it difficult to consider for the build of the control system. In this case, the coefficients of PID regulator must be calculated empirically [40, 44].

### 3.3 Optimal control

The task of optimal control is divided into several stages: the definition of quality indicators, the calculation of the optimal system of control, and the synthesis system. Usually, optimal control systems are calculated based on mathematical laws for finding extremes and calculating a boundary value problem. Synthesis is the task of nonlinear programming [45], where some of the constraints or the objective function are nonlinear. To determine the optimal control system, a mathematical model of the object is selected, which describes its behavior and state. A mathematical model should include: a control goal described using an optimality criterion, a system of differential equations describing the motion of an object, as well as initial and boundary conditions. For multi-level systems,

a hierarchical optimal control is used, where on each control level its own type of controller is calculated and afterward different levels are linked together into a single system [46]. Optimal control method, as the calculus of variations, has the following advantages [45, 47–49]: at each stage, the problem of finding an extremum is solved only in selected variables, therefore, the dimension of these problems is significantly lower compared to the initial one, that allows simplifying the search for optimal values of the desired variables; methods of the optimal control allow to solve tasks, that cannot be solved with another method, for example, complex technological objects and systems.

Optimal control can be minimized to undesirable (dynamic loads, suspension, etc.), or maximized the desired properties (speed, etc.) of the system's motion [50–52].

A comparison of control methods is shown in Fig. 6. As can be seen from the spider-diagram, the optimal control method is most suitable for controlling production mechanisms, moreover, it is possible to eliminate almost any disturbances of the technological process and increase the efficiency of the production as a whole. However, it should be noted that with an increased number of disturbances, the structure of the optimal regulator will become more complex in comparison to other controllers.

### 4 Modelling of the optimal control for the automatic manipulator of the galvanic line

Two-mass model of the automatic manipulator as shown in Fig. 7 will be taken as example for calculation of optimal control. The model could be described by a system of differential equations (Eq. (1) to (10)) [53, 54].

$$\begin{cases} m_1 \frac{d^2 x_1}{dt^2} + m_2 x_2 \frac{g}{l} = F - W; \\ m_2 \left( \frac{d^2 x_2}{dt^2} - \frac{d^2 x_1}{dt^2} \right) + m_2 x_2 \frac{g}{l} = 0; \end{cases} \quad (1)$$

where:

- $m_1$ : the reduced frame weight automatic manipulator;
- $m_2$ : the mass of the suspension with the load;
- $x_1, x_2$ : the coordinates of the centers of mass of the frame and suspension, respectively;
- $g$ : acceleration of gravity;
- $l$ : the length of the suspension;
- $F$ : total traction or braking forces acting on the frame;
- $W$ : given the strength of resistance of the frame movement.

Considering that when it moves, the frame during braking frame does not change its speed, the reduced system of

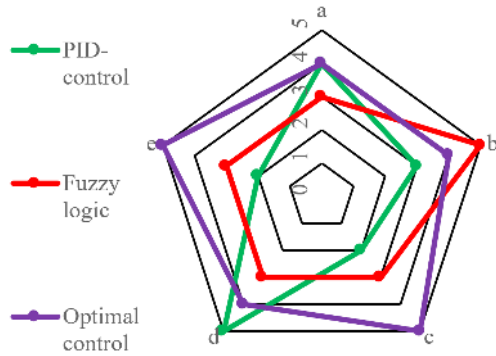

**Fig. 6** Comparison of types of control, with a: frequency of use; b: control system reconfiguration speed when changing process conditions; c: the possibility of accounting for disturbances; d: ease of implementation; e: the ability to control the speed of movement of the auto operator.

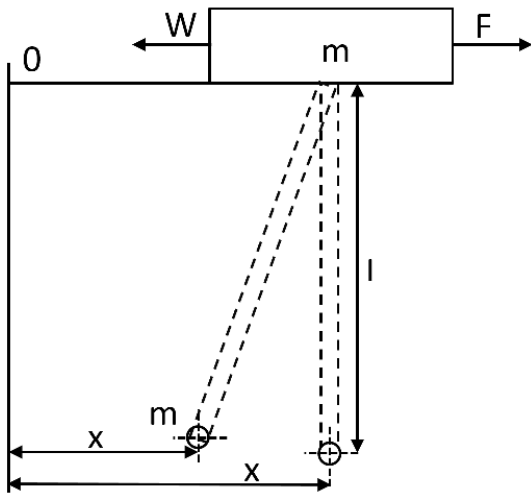

**Fig. 7** Two-mass model of the mechanism of the automatic manipulator for galvanic line.

differential equations can be reduced to a single equation of the second order:

$$\frac{d^2 x_2}{dt^2} + \omega^2 x_2 = \frac{F - W}{m_1}, \quad (2)$$

where  $\omega = \sqrt{\frac{g}{l} \left(1 + \frac{m_2}{m_1}\right)}$  is the natural frequency of the pendulum oscillation of the load relative to the moving point of suspension.

The differential Eq. (2) can be represented as a system of canonical equations, if we take the following notation

$$u = \frac{F - W}{m_1}, \quad z_1 = x_2:$$

$$\begin{cases} \dot{z}_1 = z_2; \\ \dot{z}_2 = (u - \omega^2 z_1). \end{cases} \quad (3)$$

#### 4.1 Eliminating modelling

Kinematic-dynamic integral criterion is used for optimization. This complex criterion shows in an appropriate way the proportion between a squared magnitude of the suspension deflection with the load from the vertical axis and squared dynamic component of the driving force, as follows:

$$I = \int_0^T \left[ k_1 x^2 + k_2 \left( \frac{F - W}{m_1} \right)^2 \right] dt. \quad (4)$$

The deviation of the suspension from the vertical axis leads to several undesirable consequences, therefore, the amount of deviation of the suspension from the load to the vertical axis is minimal. Minimizing the driving force dynamic component will reduce the load in the motor windings. To minimize the criterion shown in (Eq. (10)), Bellman's dynamic programming [47] method is used. The main functional equation is as follows, where  $S$  is Bellman function:

$$\min \left[ k_1 z_1^2 + k_2 u^2 + \frac{\partial S}{\partial z_1} z_2 + \frac{\partial S}{\partial z_2} (u - \omega^2 z_1) \right] = 0. \quad (5)$$

Minimizing right part of (Eq. (5)) will searching for control parameter  $u$ , for which differentiating it concerning  $u$  and equal to zero, makes:

$$2k_2 u + \frac{\partial S}{\partial z_2} = 0. \quad (6)$$

The control  $u$  finds from (Eq. (5)):

$$u = -\frac{1}{2k_2} \frac{\partial S}{\partial z_2}. \quad (7)$$

Substituting in (Eq. (5)), whereby it is obtained:

$$k_1 z_1^2 + \frac{\partial S}{\partial z_1} z_2 - \frac{\partial S}{\partial z_2} z_1 \omega^2 - \frac{1}{4k_2} \left( \frac{\partial S}{\partial z_2} \right)^2 = 0. \quad (8)$$

Eq. (8) is a linear differential equation in partial derivatives, seeking its solution in the form of a quadratic form, where  $A_1, A_2, A_3$  are constant coefficients to be determined:

$$S = A_1 z_1^2 + A_2 z_1 z_2 + A_3 z_2^2. \quad (9)$$

Taking the partial derivatives of Eq. (9) in the parameters:

$$\begin{aligned} \frac{\partial S}{\partial z_1} &= 2A_1 z_1 + A_3 z_2, \\ \frac{\partial S}{\partial z_2} &= A_3 z_1 + 2A_2 z_2, \end{aligned} \quad (10)$$

With the substitution of Eq. (10) it is obtained:

$$\left( k_1 - \frac{A_3^2}{4k_2} - A_3\omega^2 \right) z_1^2 + \left( A_3 - \frac{A_2^2}{k_2} \right) z_1^2 + \left( 2A_1 - \frac{A_2A_3}{k_2} - 2A_2\omega^2 \right) z_1z_2 = 0. \quad (11)$$

Eq. (11) is valid in the case where the expression in brackets will be zero, since  $y_1 \neq 0, y_2 \neq 0$ , Eq. (11) can be replaced by a system of nonlinear algebraic equations, as follows:

$$\begin{cases} k_1 - \frac{A_3^2}{4k_2} - A_3\omega^2 = 0, \\ A_3 - \frac{A_2^2}{k_2} = 0, \\ 2A_1 - \frac{A_2A_3}{k_2} - 2A_2\omega^2 = 0. \end{cases} \quad (12)$$

The system Eq. (14) has two real and two complex roots. One real root is selected, since the motion of the system, in this case, is smooth, and the maximum amount of control small. Substituting the roots in Eq. (13) the function of optimal control can be obtained:

$$u = \frac{z_1 \left[ k_2\omega^2 - \sqrt{k_2(k_1 + k_2\omega^4)} \right]}{k_2} - \frac{\sqrt{2}z_1z_2\sqrt{k_2 \left[ \sqrt{k_2(k_1 + k_2\omega^4)} - k_2\omega^4 \right]}}{k_2}. \quad (13)$$

It is possible to synthesize a control function perturbation modeling  $u = u(z_1, z_2, k_1, k_2, \omega)$ .

#### 4.2 Accelerating modelling

Similar to the eliminating model, kinematic-dynamic integral criteria for accelerating model are calculated as follows:

$$I = \int_0^T \left[ k_2 t^2 + k_1 \left( \frac{F - W}{m_1} \right)^2 \right] dt. \quad (14)$$

The parameter  $t$ , in this case, includes the value of the oscillations of the suspension with the load under the condition of the increased speed of the auto operator.

To minimize Eq. (14) criteria using Bellman's method [47] of dynamic programming, the main functional equation can be written as:

$$\min \left[ k_2 z_2^2 + k_1 u^2 + \frac{\partial S}{\partial z_1} z_2 + \frac{\partial S}{\partial z_2} (u - \omega^2 z_1) \right] = 0. \quad (15)$$

Minimizing right part of Eq. (15) will searching for control parameter  $u$ , for which differentiate it concerning  $u$  and equal to zero, that makes:

$$2k_1 u + \frac{\partial S}{\partial z_2} = 0. \quad (16)$$

The control  $u$  is found from Eq. (17):

$$u = -\frac{1}{2k_1} \frac{\partial S}{\partial z_2}. \quad (17)$$

Substituting it in Eq. (22), whereby it is obtained:

$$k_2 z_2^2 + \frac{\partial S}{\partial z_1} z_2 - \frac{\partial S}{\partial z_2} z_1 \omega^2 - \frac{1}{4k_1} \left( \frac{\partial S}{\partial z_2} \right)^2 = 0. \quad (18)$$

Eq. (18) is a linear differential equation in partial derivatives, seeking its solution in the form of a quadratic form, where  $A_1, A_2, A_3$  are constant coefficients to be determined:

$$S = A_1 z_2^2 + A_2 z_1 z_2 + A_3 z_1^2. \quad (19)$$

Taking the partial derivatives of Eq. (19) in the parameters:

$$\begin{aligned} \frac{\partial S}{\partial z_1} &= A_2 z_2 + 2A_3 z_1, \\ \frac{\partial S}{\partial z_2} &= 2A_1 z_2 + A_2 z_1. \end{aligned} \quad (20)$$

With the substitution of Eq. (18) into Eq. (19) it is obtained:

$$\begin{aligned} z_2^2 \left( k_2 + A_2 - \frac{A_1^2}{k_1} \right) - z_1^2 \left( A_2 \omega^2 + \frac{A_2^2}{4k_1} \right) + z_1 z_2 \left( 2A_3 - 2\omega^2 A_1 - \frac{A_1 A_2}{k_1} \right) &= 0. \end{aligned} \quad (21)$$

Eq. (21) is valid in the case where the expression in brackets will be zero, since  $y_1 \neq 0, y_2 \neq 0$ , Eq. (21) can be replaced by a system of nonlinear algebraic equations, as follows:

$$\begin{cases} k_2 + A_2 - \frac{A_1^2}{k_1} = 0, \\ A_2 \omega^2 + \frac{A_2^2}{4k_1} = 0, \\ 2A_3 - 2\omega^2 A_1 - \frac{A_1 A_2}{k_1} = 0. \end{cases} \quad (22)$$

The system of Eq. (21) has two real and two complex roots. One real root is selected, since the motion of the system, in this case, is smooth, and the maximum amount of control small. Substituting the roots in Eq. (22), the function of optimal control can be obtained:

$$u = 2\omega^2 z_1 - \frac{z_2 \sqrt{k_1(k_2 - 4\omega^2 k_1)}}{k_1}. \quad (23)$$

It is possible to synthesize a control function by accelerating modeling  $u = u(z_1, z_2, k_1, k_2, \omega)$ .



## 5 Optimal control methods

### 5.1 Bellman Dynamic Programming Method (BDPM)

Dynamic programming is a section of mathematical programming that studies a set of techniques and methods that allows to find optimal solutions based on calculating the consequences of each decision and developing the optimal strategy for subsequent decisions. The tasks of dynamic programming are multi-stage, therefore the term *dynamic programming* does not so much define a special type of task, as characterizes methods for finding solutions to individual classes of problems of mathematical programming [55]. Generally, the dynamic programming task is formulated as follows in [47]:

$$u^* = (u_1^*, u_2^*, \dots, u_n^*), \quad (24)$$

where  $u$  is the optimal control of the whole technical system, and  $u_1 \dots u_n$  is the optimal control of the parts of the technical system.

It is necessary to determine such control system  $u$ , in which the function of this system takes an extreme value in the shortest time.

The mathematical description of the Bellman dynamic programming method is presented by the following expression [47]:

$$F_0(x^{(0)}) = \max_{u = (u_1, u_2, \dots, u_n)} [W_1(x^{(0)}; u_1) + \dots + W_n(x^{(n)}; u_n)], \quad (25)$$

where  $F_0(x^{(0)})$  is the maximum gain obtained in  $n$  steps, when the system goes from the initial state to the final state when implementing the optimal control strategy, and  $W_1(x^{(0)}; u_1) \dots W_n(x^{(n)}; u_n)$  are the gains obtained for every step.

There are two types of tasks where methods of dynamic programming are usually applied [56]. First, activity planning of economical objects (enterprise, industry, etc.), taking into account changes in demand for the products produced over time. Second, the problem of the optimal distribution of resources between the different directions in time. However, the most effective application of dynamic programming is a multi-stage problem, where decisions are made step by step.

### 5.2 Pontryagin Maximum Principle (PMP)

The Pontryagin Maximum Principle (PMP) is used in cases when the stationarity condition of the control object is not tolerable. According to PMP, the optimal control is written through the Hamilton function, which is directly

connected with the Lagrange function, and then other conditions for optimal control of the object are introduced, depending on the initial and boundary conditions [48].

Conclusion and calculation of PMP are represented in [48]. PMP shows that there is such an optimal control of the object, with a corresponding trajectory of motion, at which this trajectory crosses the initial and final positions at the initial and final moments of time, and the Hamilton function reaches its maximum. PMP is used in control systems in conditions of maximum speed, and the control of the object must be of relay type without intermediate values [46].

### 5.3 First Integral Method (FIM)

The essence of the First Integral Method (FIM) consists of using the first integrals of the control equations for the motion control of the object (manipulator). Based on the FIM, optimality criteria are derived and the control system is synthesized. This method is effective for different tasks in industry, related to the movement of goods [57].

The optimal criterion of the first integral method can be written using the following equation [57]:

$$J(u) = \frac{1}{2} \int_{t_0}^{t_1} \sum_{j=1}^n \left[ \frac{u_j(t)}{k_j} \right]^2 dt, \quad (26)$$

where  $u_j(t)$  is the optimal control of every step and  $k_j$  is the reactions of the system on optimal control.

To determine the optimal control by the methods of the first integrals, it is necessary to implement the following steps [58]:

1. Determine the first integrals independent of phase displacements for the equation of motion of the manipulator.
2. Solve the Cauchy problem for optimal control and determine the constant coefficients of the system of algebraic equations describing the process of moving.
3. Using the found constants to calculate the optimal control and the extremum of the optimality criterion.

### 5.4 Test Positions Method (TPM)

Determining the optimal control of the system is also possible with the selection of test positions, which can be used to judge the further movement of the manipulator [59]. Based on Test Positions Method (TPM), control can be divided into three types [59]:

1. Hard control, which does not compensate for any displacement in the manipulator;

2. Positional control, in which the offset compensation is carried out based on the vector of generalized coordinates;
3. Sensible control, in which the offset compensation is carried out based on the vector of generalized coordinates and the actual loads on the manipulator.

Based on the set of test positions, an optimality criterion is determined for calculating the motion of the manipulator. The definition of optimal control is reduced to the problem of nonlinear mathematical programming [58] and the complexity of the calculations depends on many factors such as: the power of the set of test points; dimension of vectors; the complexity of mathematical models; restrictions imposed on the movement, etc.

### 5.5 Small Increment Method (SIM)

Small Increment Method (SIM) allows to successfully synthesize optimal control systems for oscillating and non-oscillating objects. This method allows solving the main problems of optimal control, calculation, and determination of optimal control function for multi-level control objects [60]. The main idea of the SIM is a range of initial conditions for the object is limited, therefore, there is no need to calculate the entire switching surface, which simplifies the solution of the problem. Taking into consideration the system of positional control, then, in this case, the above assumption greatly simplifies the calculation of such a system. Considering that the positional control system translates the phase point located on one of the coordinate axes to the origin, when synthesizing the optimal control system there is no need to calculate the entire switching surface, but only the part that is important for this transition [60].

In case the SIM perhaps to obtain few optimal control systems for another type of technical objects. Therefore, the optimal control for the system with position control can be written as follows [60]:

$$u = R \times \text{sign} \left[ x_n - \begin{pmatrix} c_1(g_0)x_1 + c_2(g_0)x_2 \\ + \dots + c_{n-1}(g_0)x_{n-1} \end{pmatrix} \right], \quad (27)$$

In case of optimal control over speed, the output value changes monotonously without overshoot, which allows forming the optimal control in the following form [60]:

$$u = \text{sign} \left[ \begin{pmatrix} (x(t) - x(t_1)) \times (x(t) - x(t_2)) \\ \times \dots \times (x(t) - x(t_m)) \end{pmatrix} \right]. \quad (28)$$

SIM has the following advantages [61]: simple technical implementation; the simple structure of the regulator; lower cost of the management system. Disadvantages of SIM are [61]: insignificant errors, when changing the output value can lead to a significant deviation of the last switch, therefore, the accuracy decreases; it should be mentioned that SIM does not provide a sliding mode at the endpoint, therefore, additional measurements are necessary to ensure that the system does not leave reference point.

### 5.6 Feedback method

If the control of an industrial robot is organized according to the feedback principle that ensures the reduction of the load from the arbitrary initial position to the final position, then the following variants are possible [62]:

$$\begin{aligned} M_i &= M_i^{(0)}(x, \dot{x}, y, \dot{y}), & (29) \\ (x, \dot{x}, y, \dot{y}) &\in B, \\ M_i &= M_i^{(0)}(x, \dot{x}, y, \dot{y}, x_1, y_1), \\ (x, \dot{x}, y, \dot{y}) &\in B \quad i = 1, 2, \end{aligned}$$

where  $M_i$  is the maximum gain obtained in  $i$  steps;  $x, y$  are the input and output values of the technical system;  $B$  is the range of optimal control.

As Eq. (29):

1. In the initial position:

$$(x, \dot{x}, y, \dot{y}) \in B,$$

with condition:

$$\dot{x}_0(y_1 - y_0) - \dot{y}_0(x_1 - x_0) = 0.$$

In this case, the movement to the final position with the help of the control occurs in a straight line, and the exit to the boundary is possible only at zero speed.

2. Two-stage movement:

$$(x, \dot{x}, y, \dot{y}) \in B, \quad \text{but } (x, \dot{x}, y, \dot{y}) \in \Sigma_1;$$

$$M_i = M_i^{(0)}, \quad i = 1, 2;$$

$$M_i = M_i^{(1)}, \quad i = 1, 2;$$

At the first stage, the control allows braking the load by moving in a straight line. At the second stage, the system moves into the final position similarly to the first case. The exit to the border is also possible only at zero speed.

3. Two-stage movement with initial position:

$$(x, \dot{x}, y, \dot{y}) \notin (B \cup \Sigma_1);$$

$$M_i = M_i^{(0)}, i = 1, 2;$$

At the first stage, the exit to the border is carried out by the control at a non-zero speed, because of which

the impact occurs. The second stage is similar to the two-stage movement, the trajectory is represented by a polyline [62].

Usually, oscillations do not occur in practice due to low initial speeds. However, with an increase in the initial velocity, the impact will be inevitable, which can lead to unstable operation of the manipulator [63].

The advantages of feedback method control are [64]:

- elimination of disturbances, due to inaccurate positioning at the initial moment of movement;
- parry pushes in the process of movement of the manipulator.

Main disadvantages measurement of coordinates and speed in the process of movement; more volume calculations in real conditions during the process; strict requirements for the measuring system and the processing apparatus of the robot.

### 6 Simulation

Using the methods of dynamic programming and direct variations makes it possible to achieve the optimum braking mode frame. The nature of optimal control of the frame movement in the horizontal direction is smooth, and the absolute control value does not exceed the specified limits. Optimal control advantage is found with the help of dynamic programming, which is necessary to control the function of the current phase, to enter the coordinates of the system. With the help of MATLAB, an optimal control system using the determined optimal functions  $u$  were created. Building the control schemes shown in Figs. 8 and 9,  $k_1, k_2, \omega$  coefficients were auto-tuned.

Both structure schemes include the transfer function of the auto-operator in state-space (green) and optimal regulators (blue) which is based on optimal control functions, calculated earlier.

System simulation transient plots are presented in Figs. 10 to 13. Transient time for the system with the optimal controller by perturbation modeling (Fig. 10 and Fig. 12) is 1.0 seconds, the deviation from the desired value of 0.68 and 0.41, respectively. The process transition time for the system with an optimal controller by accelerating modeling (Fig. 11 and Fig. 13) is about 0.6 seconds, the overshoot from the desired value of 0.61 and 0.1, respectively.

Simulation numerical data is presented in Table 2. When comparing the simulation results, it can be said, that the use of the artificial increase in the speed of an auto

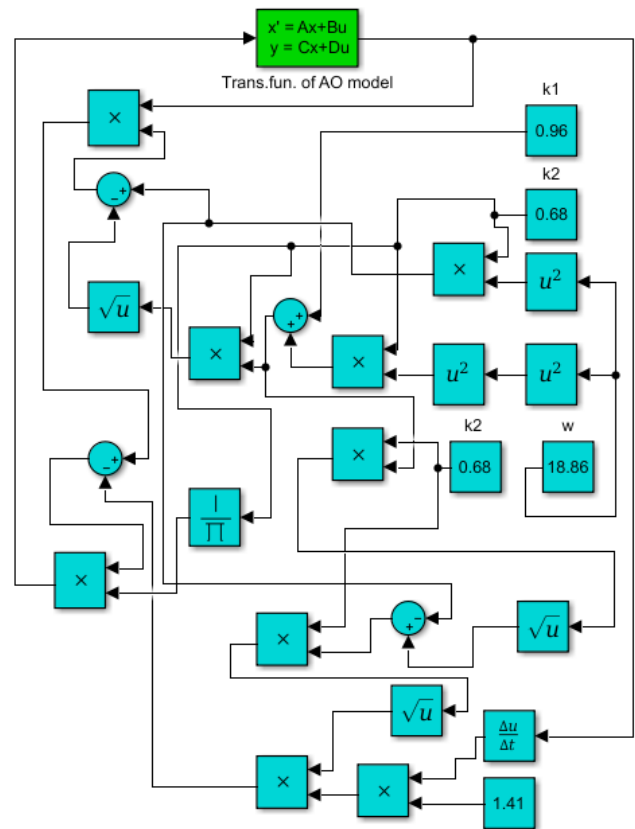

Fig. 8 Structural scheme of the system with the optimal controller by eliminated modeling.

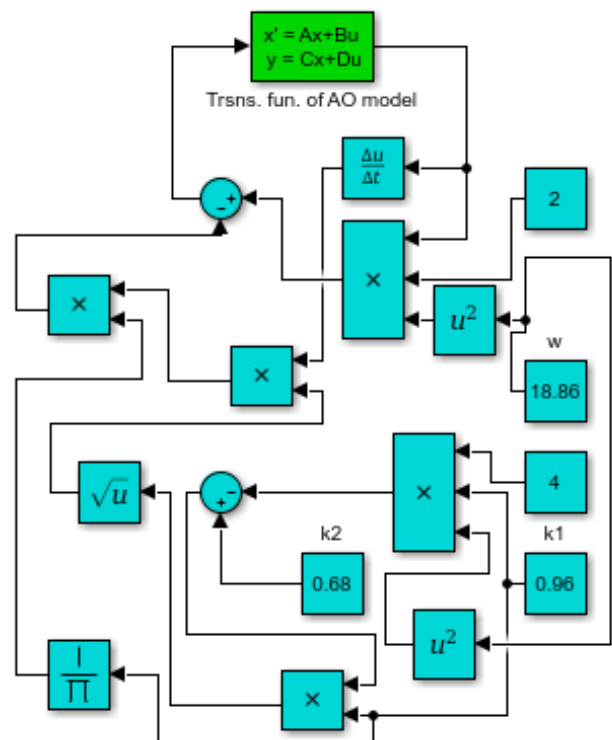
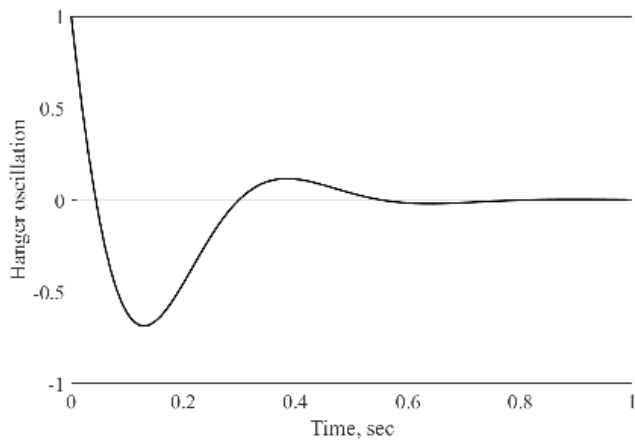
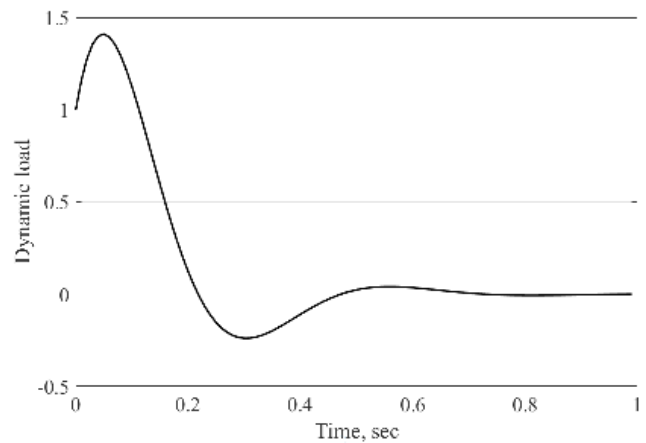

Fig. 9 Structural scheme of the system with the optimal controller by accelerating modeling.



**Fig. 10** Graph of a dynamic system by oscillations of the hanger with optimal controller by eliminated modeling.



**Fig. 12** Graph of a dynamic system by dynamic load of motor-drive with optimal controller by eliminated modeling.

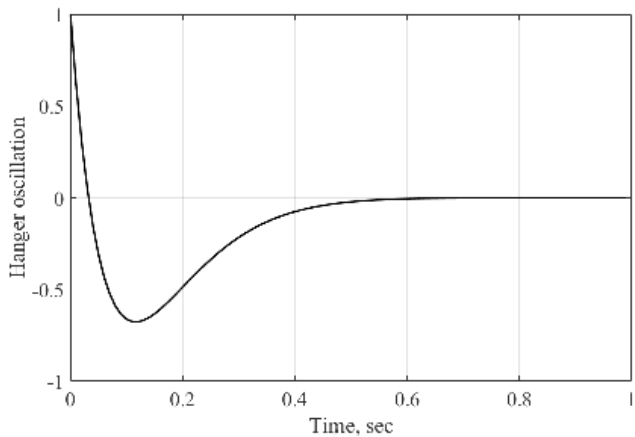

**Fig. 11** Graph of a dynamic system by oscillations of the hanger with optimal controller by accelerating modeling.

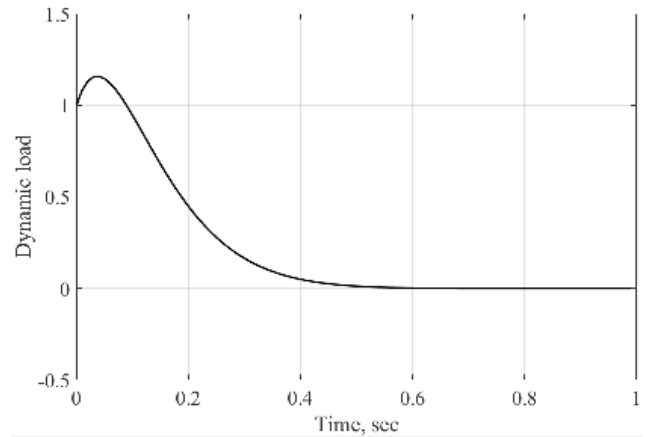

**Fig. 13** Graph of a dynamic system by dynamic load of motor-drive with the optimal controller by accelerating modeling.

**Table 2** Comparison of basic characteristics of auto-operators types

Name of modeling	Name of process	Time of transient process, sec	Over-shoot
Eliminating modelling	Hanger oscillation	1.0	0.68
	Dynamic load		0.41
Accelerating modeling	Hanger oscillation	0.6	0.61
	Dynamic load		0.1

operator's operation under conditions of suspension oscillation with a load, leads to more positive results than using only the oscillation magnitude parameter.

However, it is worth noting that the value of overshoot in the case of accelerated modeling for the magnitude of suspension oscillations is much higher than for eliminated modeling, but the value of overshoot for dynamic loads in the motor windings is almost two times less. The experimental validation of the proposed control method will be presented in further publication works by the authors.

## 7 Discussion and conclusion

Galvanization is a technological treatment process is widely applied in manufacturing. The coating stage of galvanizing is related to the movement of the auto-operator. As it has been discussed in the paper, the work of an auto-operator is strictly cyclical, which has a significant impact on its work. Depending on the type of the auto-operator, the transients of the transfer of parts in the galvanic line are accompanied by the appearance of load oscillations. By proper selection of the control method and its settings for the auto operator, these fluctuations can be reduced and production efficiency improved.

As it was established in the paper, the use of adaptive (optimal) control allows one to accomplish the task given the following advantages:

- the possibility of accounting for disturbances;
- ability to control the speed of movement of the auto-operator;
- ease of implementation.

The main algorithms of optimal control for eliminating load oscillations, when moving it by the means of the auto-operator in a galvanic line, are discussed in the paper.

Other studied algorithms have significant drawbacks, that prevent them from being applied to the studied system:

- small increment method and feedback method, presented in the paper, have the presence of a "strike" at the beginning or the end of the transition process, thereby increasing the load on the drive elements and the efficiency of the auto-operator;
- test position method and first integral method include a large number of mathematical calculations or the presence of a large number of parameters, which allows achieving optimal control and practical implementation within the galvanic production.

When comparing the Bellman dynamic programming method and the Pontryagin maximum principle, it is clear that the first method has several advantages over the second one. The Bellman method allows not only to speed up the work of the auto-operator but also to eliminate the load oscillations, as well as reduce the load on the electric motor, while the maximum principle is mainly used only for tasks to increase the speed of operation of technological systems. That was proven by the calculation of the optimal control system. The current definition of the control system is based on a two-mass model of the auto-operator and produced by two parameters:

## References

- [1] Tuutti, K. "Corrosion of steel in concrete", PhD Thesis, Swedish Cement and Concrete Research Institute, 1982.
- [2] Pokorný, P., Dobiáš, D., Vokáč, M. "Bond strength of HOT - Dip galvanized reinforcement (B500b) with concrete", *Metalurgija – Sisak* then Zagreb, 55(3), pp. 337–340, 2016.
- [3] Vinogradov, S. "Organization of electroplating. Equipment, production calculation, rationing", Globus Publication, Moscow, Russia, 2005.
- [4] Vorotnikov, S. A. "Informative devices of robotic systems", Publishing House of Moscow State Technical University, Moscow, Russia, 2005.
- [5] Zenkevich, S. L., Yushchenko, A. S. "Basics of Manipulating Robots", Publishing House of Moscow State Technical University, Moscow, Russia, 2004.
- [6] Макаров, И., Торчеев, Я. "Робототехника: история и перспективы" (Robotics: History and Prospects), MAI Publishing House, Place of Publishing, Country, 2003. (in Russian)
- [7] Egorov, I. N. "Positional-power control of robotic and mechatronic devices", Publishing House of Vladimir State University, Vladimir, Russia, 2010.
- [8] Ivanov, A. A. "Basics of robotics", INFRA-M, Moscow, Russia, 2017.
- [9] Kuts, V., Tahemaa, T., Otto, T., Sarkans, M., Lend, H. "Robot manipulator usage for measurement in production areas", *Journal of Mechanical Engineering*, 16(1), pp. 57–67, 2016.
- [10] Rassõlkin, A., Hõimoja, H., Teemets, R. "Energy saving possibilities in the industrial robot IRB 1600 control", In: 2011 7th International Conference-Workshop Compatibility and Power Electronics (CPE), Tallinn, Estonia, 2011, pp. 226–229. <https://doi.org/10.1109/CPE.2011.5942236>
- [11] Merlet, J. P. "Parallel Robots", Springer, Dordrecht, Netherlands, 2006. <https://doi.org/10.1007/1-4020-4133-0>
- [12] Schilling, R. J. "Fundamentals of Robotics: Analysis & Control", Prentice Hall, Upper Saddle River, NJ, USA, 2005.
- [13] Kozyrev, Y. G. "Industrial robots", Mashinostroenie, Moscow, Russia, 2011.
- [14] Kuts, V., Sarkans, M., Otto, T., Tahemaa, T. "Collaborative Work Between Human And Industrial Robot In Manufacturing By Advanced Safety Monitoring System", In: 28th DAAAM International Symposium on Intelligent Manufacturing and Automation, Zadar, Croatia, 2017, pp. 0996–1001. <https://doi.org/10.2507/28th.daaam.proceedings.138>

oscillation and time. As a result of the simulation, two optimal control functions were obtained in two directions: eliminated modeling and accelerating modeling, on the basis of which the controllers for the auto-operator control system were synthesized.

Structure schemes of optimal control systems and the results of modeling, as well as the comparison of both systems, are also discussed in the paper. It should be noticed that the optimal control systems, described in the article, can be adapted not only for various types of auto-operators for galvanic lines but also for other mechanical means used in industry, such as port and tower cranes, robotic assembly lines, conveyor (transport) lines, etc. It is important to note that the use of this method, with an increase in the number of variables, leads to a complication of the structure of the regulator. Therefore, when applying the optimal control method to eliminate oscillations based on the dynamic method, it is necessary to make Bellman's programming with a well-thought-out substitute-effect connection between them.

Implementation of such optimization methodology may be used also for other application, e.g. as a part of digital twin of the control entity for autonomous electric vehicle [65] for proper system tuning and optimization.

## Acknowledgement

The research has been supported by the Estonian Research Council under grant PSG453 and was financially supported by Government of Russian Federation (Grant 08-08).



- [15] Gogu, G. "Structural Synthesis of Parallel Robots", Springer, Dordrecht, Netherlands, 2008.  
<https://doi.org/10.1007/978-1-4020-5710-6>
- [16] Tho, H. D., Tasaki, R., Miyoshi, T., Terashima, K. "Optimal Control of Payload's Skew Rotation in Crane Systems with State and Control Input Constraints", In: 2018 IEEE Conference on Control Technology and Applications (CCTA), Copenhagen, Denmark, 2018, pp. 729–735.  
<https://doi.org/10.1109/CCTA.2018.8511443>
- [17] Adams, C., Potter, J., Singhose, W. "Modeling and input shaping control of a micro coaxial radio-controlled helicopter carrying a suspended load", In: 2012 12th International Conference on Control, Automation and Systems, JeJu Island, South Korea, 2012, pp. 645–650.
- [18] Zhang, F., Keikha, E., Shahsavari, B., Horowitz, R. "Adaptive mismatch compensation for vibratory gyroscopes", 2014 International Symposium on Inertial Sensors and Systems (ISISS), Laguna Beach, CA, USA, 2014, pp. 1–4.  
<https://doi.org/10.1109/ISISS.2014.6782514>
- [19] Shi, Z., Zhao, L. "Adaptive output feedback autopilot design for spinning projectiles", In: 2017 36th Chinese Control Conference (CCC), Dalian, China, 2017, pp. 3516–3521.  
<https://doi.org/10.23919/ChiCC.2017.8027902>
- [20] Wang, C., Yang, M., Zheng, W., Hu, K., Xu, D. "Analysis and Suppression of Limit Cycle Oscillation for Transmission System With Backlash Nonlinearity", IEEE Transactions on Industrial Electronics, 64(12), pp. 9261–9270, 2017.  
<https://doi.org/10.1109/TIE.2017.2711564>
- [21] Zhang, Q., He, Y., Li, L., Nurzat, N. "Sliding Mode Control of Rotary Drilling System with Stick Slip Oscillation", In: 2010 2nd International Workshop on Intelligent Systems and Applications, Wuhan, China, 2010, pp. 1–4.  
<https://doi.org/10.1109/IWISA.2010.5473281>
- [22] Uyanik, I., Saranlı, U., Morgül, Ö. "Adaptive control of a spring-mass hopper", In: 2011 IEEE International Conference on Robotics and Automation, Shanghai, China, 2011, pp. 2138–2143.  
<https://doi.org/10.1109/ICRA.2011.5979726>
- [23] Liu, H., Hu, M., Yu, H., Yu, L. "Study on fuzzy control in electromagnetic suspension system based on the prediction model", In: 2010 International Conference on Intelligent Control and Information Processing, Dalian, China, 2010, pp. 725–728.  
<https://doi.org/10.1109/ICICIP.2010.5564196>
- [24] Fubin, S., Linxiu, S., Lin, L., Qizhi, Z. "Adaptive PID control of rotary drilling system with stick slip oscillation", In: 2010 2nd International Conference on Signal Processing Systems, Dalian, China, 2010, pp. V2-289–V2-292.  
<https://doi.org/10.1109/ICSPS.2010.5555490>
- [25] Varghese, E. S., Vincent, A. K., Bagyaveereswaran, V. "Optimal control of inverted pendulum system using PID controller, LQR and MPC", IOP Conference Series: Materials Science and Engineering, 263(5), Article Number: 052007, 2017.  
<https://doi.org/10.1088/1757-899X/263/5/052007>
- [26] Yu, J., Shi, P., Dong, W., Lin, C. "Adaptive Fuzzy Control of Nonlinear Systems with Unknown Dead Zones Based on Command Filtering", IEEE Transactions on Fuzzy Systems, 26(1), pp. 46–55, 2018.  
<https://doi.org/10.1109/TFUZZ.2016.2634162>
- [27] Segatori, A., Marcelloni, F., Pedrycz, W. "On Distributed Fuzzy Decision Trees for Big Data", IEEE Transactions on Fuzzy Systems, 26(1), pp. 174–192, 2018.  
<https://doi.org/10.1109/TFUZZ.2016.2646746>
- [28] Lukichev, D. V., Demidova, G. L., Brock, S. "Fuzzy adaptive PID control for two-mass servo-drive system with elasticity and friction", In: 2015 IEEE 2nd International Conference on Cybernetics (CYBCONF), Gdynia, Poland, 2015, pp. 443–448.  
<https://doi.org/10.1109/CYBConf.2015.7175975>
- [29] Lukichev, D. V., Demidova, G. L., Brock, S. "Comparison of Adaptive Fuzzy PID and ANFIS Controllers for Precision Positioning of Complex Object with Nonlinear Disturbance - Study and Experiment", In: 2018 20th European Conference on Power Electronics and Applications (EPE'18 ECCE Europe), Riga, Latvia, 2018, pp. P.1–P.9.
- [30] Tannahill, B. K., Maute, C. E., Yetis, Y., Ezell, M. N., Jaimes, A., Rosas, R., Motaghi, A., Kaplan, H., Jamshidi, M. "Modeling of system of systems via data analytics - Case for "Big Data" in SoS", In: 2013 8th International Conference on System of Systems Engineering, Maui, HI, USA, 2013, pp. 177–183.  
<https://doi.org/10.1109/SYSoSE.2013.6575263>
- [31] Yu, Z., Chen, H., You, J., Liu, J., Wong, H. S., Han, G., Li, L. "Adaptive Fuzzy Consensus Clustering Framework for Clustering Analysis of Cancer Data", IEEE/ACM Transactions on Computational Biology and Bioinformatics, 12(4), pp. 887–901, 2015.  
<https://doi.org/10.1109/TCBB.2014.2359433>
- [32] Zhang, L., Wang, W., Shi, Y. "Research on maximum power point tracking based on an improved fuzzy-PD dual-mode algorithm", In: 2017 10th International Congress on Image and Signal Processing, BioMedical Engineering and Informatics (CISP-BMEI), Shanghai, China, 2017, pp. 1–6.  
<https://doi.org/10.1109/CISP-BMEI.2017.8302309>
- [33] Marcus, S., Mihai, F. I. F., Sorin, M., Ciprian, S. "The implementation of the fuzzy logic controller for permanent magnet synchronous machines", Eurocon 2013, Zagreb, Croatia, 2013, pp. 1988–1991.  
<https://doi.org/10.1109/EUROCON.2013.6625252>
- [34] Demidova, G. L., Lukichev, D. V., Kuzin, A. Y. "A Genetic Approach for Auto-Tuning of Adaptive Fuzzy PID Control of a Telescope's Tracking System", Procedia Computer Science, 150, pp. 495–502, 2019.  
<https://doi.org/10.1016/j.procs.2019.02.084>
- [35] Zhang, J., Deng, Z., Choi, K. S., Wang, S. "Data-Driven Elastic Fuzzy Logic System Modeling: Constructing a Concise System With Human-Like Inference Mechanism", IEEE Transactions on Fuzzy Systems, 26(4), pp. 2160–2173, 2018.  
<https://doi.org/10.1109/TFUZZ.2017.2767025>
- [36] Zadeh, L. A. "Fuzzy logic and approximate reasoning", Synthese, 30(3), pp. 407–428, 1975.  
<https://doi.org/10.1007/BF00485052>
- [37] Zadeh, L. A. "The concept of a linguistic variable and its application to approximate reasoning—I", 8(3), pp. 199–249, 1975.  
[https://doi.org/10.1016/0020-0255\(75\)90036-5](https://doi.org/10.1016/0020-0255(75)90036-5)
- [38] Bolognani, S., Zigliotto, M. "Hardware and software effective configurations for multi-input fuzzy logic controllers", IEEE Transactions on Fuzzy Systems, 6(1), pp. 173–179, 1998.  
<https://doi.org/10.1109/91.660817>

- [39] Uddin, M. N., Radwan, T. S., Rahman, M. A. "Performances of fuzzy-logic-based indirect vector control for induction motor drive", *IEEE Transactions on Industry Application*, 38(5), pp. 1219–1225, 2002.  
<https://doi.org/10.1109/TIA.2002.802990>
- [40] Ang, K. H., Chong, G., Li, Y. "PID control system analysis, design, and technology", *IEEE Transactions on Control Systems Technology*, 13(4), pp. 559–576, 2005.  
<https://doi.org/10.1109/TCST.2005.847331>
- [41] Gevorkov, L., Rassölkin, A., Kallaste, A., Vaimann, T. "Simulation study of mixed pressure and flow control systems for optimal operation of centrifugal pumping plants", *Electrical, Control, and Communication Engineering*, 14(1), pp. 89–94, 2018.  
<https://doi.org/10.2478/ecce-2018-0010>
- [42] Rassölkin, A., Sell, R., Leier, M. "Development Case Study of the First Estonian Self-Driving Car, ISEAUTO", *Electrical, Control and Communication Engineering*, 14(1), pp. 81–88, 2018.  
<https://doi.org/10.2478/ecce-2018-0009>
- [43] Hahn, J. "Handbook of PI and PID Controller Tuning Rules – [Book Review]", *IEEE Control Systems Magazine*, 26(1), pp. 92–93, 2006.  
<https://doi.org/10.1109/MCS.2006.1580157>
- [44] Araki, M. "PID Control", In: Unbehauen, H. (ed.) *Control Systems, Robotics, and Automation – Volume II: System Analysis and Control: Classical Approaches II*, *Encyclopedia of Life Support Systems (EOLSS)*, EOLSS Publications, Oxford, UK, 2009.
- [45] Dasgupta, S., Papadimitriou, C. H., Vazirani, U. V. "Algorithms", McGraw-Hill Education, New Delhi, India, 2006.
- [46] Tanwani, A., Henrion, D. "Calculus of variations, optimal control, and optimization", In: *Module Edsys'18: Optimal Control*, Equipe MAC, LAAS, Toulouse, France, Jan, 22–25, 2018.
- [47] Bellman, R. E. "Dynamic Programming", Princeton University Press, Princeton, NJ, USA, 2010.
- [48] Dmitruk, A. V. "On the development of Pontryagin's Maximum Principle in the works of A.Ya. Dubovitskii and A.A. Milyutin", *Control and Cybernetics*, 38(4), pp. 923–957, 2009.
- [49] Neumaier, A., Shcherbina, O. "Nonserial dynamic programming and local decomposition algorithms in discrete programming", *Optimization Online*, pp. 1–12, 2006.
- [50] Aghili, F. "Optimal Feedback Linearization Control of Interior PM Synchronous Motors Subject to Time-Varying Operation Conditions Minimizing Power Loss", *IEEE Transactions on Industrial Electronics*, 65(7), pp. 5414–5421, 2018.  
<https://doi.org/10.1109/TIE.2017.2784348>
- [51] Yang, L., He, D., Wang, Q., Luo, J., Huang, Y., Zhen, Z. "Particle Swarm Optimization Algorithm Based on Robust Control of Random Discrete Systems", In: *2017 4th International Conference on Information Science and Control Engineering (ICISCE)*, Changsha, China, 2017, pp. 1089–1093.  
<https://doi.org/10.1109/ICISCE.2017.227>
- [52] Ding, F., Huang, J., Wang, Y., Matsuno, T., Fukuda, T. "Vibration damping in manipulation of deformable linear objects using sliding mode control", *Advanced Robotics*, 28(3), pp. 157–172, 2014.  
<https://doi.org/10.1080/01691864.2013.861769>
- [53] Saroka, V., Autsou, S. "Synthesis of the control system of the robot manipulator of galvanic lines using the Bellman dynamic programming method", In: *2017 Open Conference of Electrical, Electronic and Information Sciences (eStream)*, Vilnius, Lithuania, 2017, pp. 1–4.  
<https://doi.org/10.1109/eStream.2017.7950328>
- [54] Saroka, V. V., Autsou, S. A. "Synthesis of optimal control systems for braking process for automatic manipulator frame", In: *2016 Open Conference of Electrical, Electronic and Information Sciences (eStream)*, Vilnius, Lithuania, 2016, pp. 1–4.  
<https://doi.org/10.1109/eStream39242.2016.7485914>
- [55] Aleksandrov, A. G. "Synthesis of controllers in terms of accuracy and speed", *A&T*, 5, pp. 27–42, 2015.
- [56] Balandin, D. V., Kogan, M. M. "Design of Pareto-Optimal Linear Quadratic Estimates, Filters and Controllers", *Automation and Remote Control*, 79(1), pp. 24–38, 2018.  
<https://doi.org/10.1134/S0005117918010034>
- [57] Grigoryev, M. A., Gorozhankin, A. N., Kinas, S. I., Belousov, E. V. "Dynamic parameters of active rectifiers", *Russian Electrical Engineering*, 85(10), pp. 638–640, 2014.  
<https://doi.org/10.3103/S1068371214100083>
- [58] Shcherbina, O. A. "Methodological aspects of dynamical programming", *Dinamicheskie sistemy*, 22, pp. 21–36, 2007.
- [59] Kosmatopoulos, E. B. "Control of Unknown Nonlinear Systems With Efficient Transient Performance Using Concurrent Exploitation and Exploration", *IEEE Transactions on Neural Networks*, 21(8), pp. 1245–1261, 2010.  
<https://doi.org/10.1109/TNN.2010.2050211>
- [60] Denisov, A. I. "Синтез оптимальных по быстродействию систем управления методом малых приращений" (Synthesis of optimal speed control systems by the method of small increments), PhD Thesis, Tuvan State University, 1999. (in Russian)
- [61] Azanov, V. M., Kan, Y. S. "Design of optimal strategies in the problems of discrete system control by the probabilistic criterion", *Automation and Remote Control*, 78(6), pp. 1006–1027, 2017.  
<https://doi.org/10.1134/S0005117917060042>
- [62] Reutenberg, Y. N. "Автоматическое управление" (Automatic control), Nauka Publishing House, Moscow, Russia, 1991.
- [63] Armbruster, D., Fonteijn, J., Wienke, M. "Modeling production planning and transient clearing functions", *Logistics Research*, 5(3), pp. 133–139, 2012.  
<https://doi.org/10.1007/s12159-012-0087-8>
- [64] Berbyuk, V. E. "Dynamics and optimization of robotic systems", Naukova Dumka, Kiev, Ukraine, 1995.
- [65] Rassölkin, A., Vaimann, T., Kallaste, A., Kuts, V. "Digital twin for propulsion drive of autonomous electric vehicle", In: *2019 IEEE 60th International Scientific Conference on Power and Electrical Engineering of Riga Technical University (RTUCON)*, Riga, Latvia, 2019, pp. 1–4.  
<https://doi.org/10.1109/RTUCON48111.2019.8982326>