

Optimal Control with Unreliable Communication: the TCP Case

Bruno Sinopoli*, Luca Schenato**, Massimo Franceschetti***,
Kameshwar Poolla*, Shankar S. Sastry*

* *Department of Electrical Engineering and Computer Sciences
University of California at Berkeley,*

{sinopoli,poolla,sastry}@eecs.berkeley.edu,

** *Department of Information Engineering*

University of Padova, Italy,

schenato@dei.unipd.it,

*** *Department of Electrical and Computer Engineering*

University of California at San Diego,

massimo@ece.ucsd.edu

Abstract—The paper considers the Linear Quadratic Gaussian (LQG) optimal control problem in the discrete time setting and when data loss may occur between the sensors and the estimation-control unit and between the latter and the actuation points. We consider the case where the arrival of the control packet is acknowledged at the receiving actuator, as it happens with the common Transfer Control Protocol (TCP). We start by showing that the separation principle holds. Additionally, we can prove that the optimal LQG control is a linear function of the state. Finally, building upon our previous results on estimation with unreliable communication, the paper shows the existence of critical arrival probabilities below which the optimal controller fails to stabilize the system. This is done by providing analytic upper and lower bounds on the cost functional.

I. INTRODUCTION

Today, a growing number of applications demands remote control of plants over unreliable networks. Examples are wireless sensor networks used for estimation and control of dynamical systems [1]. In these systems issues of communication delay, data loss, and time synchronization between components play a key role. In short, communication and control become tightly coupled such that the two issues cannot be addressed independently.

Consider, for example, the problem of navigating a vehicle based on the estimate from a sensor web of its current position and velocity. The measurements underlying this estimate can be lost or delayed due to the unreliability of the wireless links. What is the amount of data loss that the control loop can tolerate to reliably perform the navigation task? Can communication protocols be designed to satisfy this constraint? The goal of this paper is to examine some control-theoretic implications of using unreliable networks for control. These require a generalization of classical control techniques that explicitly take into account the stochastic nature of the communication channel.

Communication channels typically use one of two kinds of protocols: Transmission Control (TCP) or User Data-

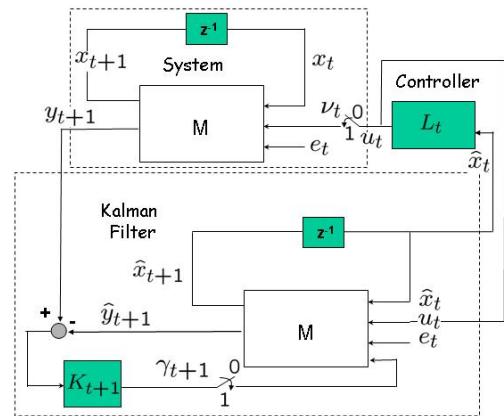

Fig. 1. **Overview of the system.** We study the statistical convergence of the expected state covariance of the discrete time LQG, where both the observation and the control signal, travelling over an unreliable communication channel, can be lost at each time step with probability $1 - \bar{\gamma}$ and $1 - \bar{\nu}$ respectively.

gram (UDP). In the first case there is acknowledgement of received packets, while in the second case no-feedback is provided on the communication link. We study the effect of data losses due to the unreliability of the network links in the TCP case. We generalize the Linear Quadratic Gaussian (LQG) optimal control problem —modeling the arrival of an observation as a random process whose parameters are related to the characteristics of the communication channel. Accordingly, we consider two independent Bernoulli processes, of parameters $\bar{\gamma}$ and $\bar{\nu}$, that govern packet loss between the sensors and the estimation-control unit, and between the latter and the actuation points, see Figure 1.

In our previous work [2] we have determined the optimal LQG controller for the case when data loss occurs only between sensors and estimator. We have also shown that the

separation principle still holds under this assumption, hence, the optimal controller is linear with the state. In this paper we consider the more general case in which data loss occurs also between the controller and the actuator. Accordingly, we show that in the TCP case the separation principle holds and the optimal controller is a linear function of the state. We also show the existence of critical values for the parameters of the Bernoulli arrival processes, below which a transition to instability occurs and the optimal controller fails to stabilize the system. In other words, in order to have stability, the packet loss rate must be below a given threshold that depends on the dynamics of the system.

Following the procedure and using the result in [3], [4] we are able to prove the existence of a critical value for the arrival rate above which the optimization problem is bounded, and below which the cost J goes unbounded. This is accomplished by finding deterministic upper and lower bounds for the expected optimal cost and their convergence conditions.

Study of stability of dynamical systems where component are connected asynchronously via communication channels has received considerable attention in the past few years and our contribution can be put in the context of the previous literature. Ling and Lemmon [5], in a series of papers, proposed a compensator approach for some data loss models. They consider an optimal compensator design when data loss is i.i.d. A different approach was considered in [6] which proposed to place an estimator, i.e. a Kalman filter, at the sensor side of the link and without assuming any statistical model for the data loss process. The work of [7] is the closest to the present paper, but we consider the more general case when the matrix C is not the identity and there is noise in the observation. Moreover we analyze the infinite horizon case.

Nilsson [8] presents the LQG optimal regulator with bounded delays between sensors and controller, and between the controller and the actuator, but he does not address the packet-loss case. This is considered by Hadjicostis and Touri [9], where dropped measurements are replaced by zeros. Other approaches include using the last received sample for control, or designing a dropout compensator [10], [5]. We consider the alternative approach where the external compensator feeding the controller is the optimal time varying Kalman gain. Moreover, we analyze the proposed solution in state space domain rather than in frequency domain as it was presented in [5], and we consider the more general Multiple Input Multiple Output (MIMO) case.

The paper is organized as follows. The next section provides a mathematical formulation for the problem. Section III provide some preliminary results in the form of lemmas, which we then use to prove our main results in section IV. We finally conclude and provide directions for future work in section V.

II. PROBLEM FORMULATION

Consider the following linear stochastic system with intermittent observations:

$$x_{k+1} = Ax_k + \nu_k B u_k + w_k \quad (1)$$

$$y_k = Cx_k + v_k, \quad (2)$$

where $x_k \in \mathbb{R}^n$ is the state vector, $y_k \in \mathbb{R}^m$ is the output vector, $u_k \in \mathbb{R}^q$ is the input vector, $x_0 \in \mathbb{R}^n$, $w_k \in \mathbb{R}^n$ and $v_k \in \mathbb{R}^m$ are Gaussian, uncorrelated, white, with zero mean and covariance (P_0, Q, R_k) respectively, $R_k = \gamma_k R + (1 - \gamma_k)\sigma^2 I$, and (γ_k, ν_k) are i.i.d. Bernoulli random variables with $P(\gamma_k = 1) = \bar{\gamma}$ and $P(\nu_k = 1) = \bar{\nu}$. Let us define the following information set:

$$\mathcal{I}_k \triangleq \{\mathbf{y}^k, \gamma^k, \nu^{k-1}\}, \quad (3)$$

where $\mathbf{y}^k = (y_k, y_{k-1}, \dots, y_1)$, $\gamma^k = (\gamma_k, \gamma_{k-1}, \dots, \gamma_1)$, and $\nu^k = (\nu_k, \nu_{k-1}, \dots, \nu_1)$.

Consider also the following cost function:

$$\begin{aligned} J_N(\mathbf{u}^{N-1}) &= \quad (4) \\ &= \mathbb{E} \left[x'_N W_N x_N + \sum_{k=0}^{N-1} (x'_k W_k x_k + \nu_k u'_k U_k u_k) \mid \mathcal{I}_N \right]. \end{aligned}$$

We now look for a control input sequence \mathbf{u}^{*N-1} that minimizes the above functional given that the information \mathcal{I}_k is available at time k , i.e.

$$J_N^* = \min_{\mathbf{u}^{N-1}} J_N(\mathbf{u}^{N-1}) = J_N(\mathbf{u}^{*N-1}) \quad (5)$$

where $u_k^* = u_k^*(\mathcal{I}_k)$ and \mathcal{I}_k is defined in Equation 3.

III. MATHEMATICAL BACKGROUND

Before proceeding, let us define the following variables:

$$\begin{aligned} \hat{x}_{k|k} &\triangleq \mathbb{E}[x_k \mid \mathcal{I}_k], \\ e_{k|k} &\triangleq x_k - \hat{x}_{k|k}, \\ P_{k|k} &\triangleq \mathbb{E}[e_{k|k} e'_{k|k} \mid \mathcal{I}_k]. \end{aligned} \quad (6)$$

In the following derivation we will make use of the following facts

Lemma 1. *The following facts are true:*

- (a) $\mathbb{E}[(x_k - \hat{x}_k)\hat{x}'_k \mid \mathcal{I}_k] = \mathbb{E}[e_{k|k}\hat{x}'_k \mid \mathcal{I}_k] = 0$
- (b) $\mathbb{E}[x'_k S x_k \mid \mathcal{I}_k] = \hat{x}'_k S \hat{x}_k + \text{trace}(S P_{k|k}) = \hat{x}'_k S \hat{x}_k + \mathbb{E}[e'_{k|k} S e_{k|k} \mid \mathcal{I}_k], \quad \forall S$
- (c) $\mathbb{E}[\mathbb{E}[g(x_{k+1}) \mid \mathcal{I}_{k+1}] \mid \mathcal{I}_k] = \mathbb{E}[g(x_{k+1}) \mid \mathcal{I}_k], \quad \forall g(\cdot)$

Proof: (a) It follows directly from the definition. In fact: $\mathbb{E}[(x_k - \hat{x}_k)\hat{x}'_k \mid \mathcal{I}_k] = \mathbb{E}[x_k \hat{x}'_k - \hat{x}_k \hat{x}'_k \mid \mathcal{I}_k] = \mathbb{E}[x_k \mid \mathcal{I}_k] \hat{x}'_k - \hat{x}_k \hat{x}'_k = 0$

(b) Using standard algebraic operations and the previous fact we have:

$$\begin{aligned} \mathbb{E}[x'_k S x_k \mid \mathcal{I}_k] &= \mathbb{E}[(x_k - \hat{x}_k + \hat{x}_k)' S (x_k - \hat{x}_k + \hat{x}_k) \mid \mathcal{I}_k] \\ &= \hat{x}'_k S \hat{x}_k + \mathbb{E}[(x_k - \hat{x}_k)' S (x_k - \hat{x}_k)] + \\ &+ 2\mathbb{E}[\hat{x}'_k S (x_k - \hat{x}_k) \mid \mathcal{I}_k] \\ &= \hat{x}'_k S \hat{x}_k + 2\text{trace}\{S \mathbb{E}[(x_k - \hat{x}_k)\hat{x}'_k \mid \mathcal{I}_k]\} + \\ &+ \text{trace}\{S \mathbb{E}[(x_k - \hat{x}_k)(x_k - \hat{x}_k)' \mid \mathcal{I}_k]\} \\ &= \hat{x}'_k S \hat{x}_k + \text{trace}\{S P_{k|k}\} \end{aligned}$$

(c) Let (X, Y, Z) be any random vectors, $g(\cdot)$ any function, and p the probability distribution, then

$$\begin{aligned} & \mathbb{E}_{Y,Z} [g(X, Y, Z) | X] = \\ &= \int_Z \int_Y g(X, Y, Z) p(Y, Z|X) dY dZ \\ &= \int_Z \int_Y g(X, Y, Z) p(Y|Z, X) p(Z|X) dY dZ \\ &= \int_Z \left[\int_Y g(X, Y, Z) p(Y|Z, X) dY \right] p(Z|X) dZ \\ &= \mathbb{E}_Z [\mathbb{E}_Y [g(X, Y, Z) | Z, X] | X]. \end{aligned}$$

where we used Bayes' Rule. Since $\mathcal{I}_k \subseteq \mathcal{I}_{k+1}$, fact (c) follows from the above equality by substituting $\mathcal{I}_k = X$ and $\mathcal{I}_{k+1} = (X, Z)$. ■

We now compute some quantities that will prove to be useful when deriving the equation for the optimal LQG controller. Let us compute the following expectation:

$$\begin{aligned} & \mathbb{E}[x'_{k+1} S x_{k+1} | \mathcal{I}_k] = \\ &= \mathbb{E}[(Ax_k + \nu_k B u_k + w_k)' S (Ax_k + \nu_k B u_k + w_k) | \mathcal{I}_k] \\ &= \mathbb{E}[x'_k A' S A x_k + \nu_k^2 u'_k B' S B u_k + w'_k S w_k + \\ &+ 2\nu_k u'_k B' S A x_k + 2(Ax_k + \nu_k B u_k) w_k | \mathcal{I}_k] = \\ &= \mathbb{E}[x'_k A' S A x_k | \mathcal{I}_k] + \bar{\nu} u'_k B' S B u_k + \\ &+ 2\bar{\nu} u'_k B' S A \mathbb{E}[x_k | \mathcal{I}_k] + \text{trace}(S \mathbb{E}[w_k w'_k | \mathcal{I}_k]) = \\ &= \mathbb{E}[x'_k A' S A x_k | \mathcal{I}_k] + \bar{\nu} u'_k B' S B u_k + \\ &+ 2\bar{\nu} u'_k B' S A \hat{x}_{k|k} + \text{trace}(S Q) \end{aligned} \quad (7)$$

where we used independence of ν_k , w_k , x_k , and zero-mean property of w_k . Also

$$\mathbb{E}[e'_{k|k} T e_{k|k} | \mathcal{I}_k] = \text{trace}(T \mathbb{E}[e_{k|k} e'_{k|k} | \mathcal{I}_k]) = \text{trace}(T P_{k|k}). \quad (8)$$

IV. FINITE AND INFINITE HORIZON LQG

We first start finding the optimal estimator, which will be needed to solve the LQG controller design, as it will be shown later.

A. Estimator Design, $\sigma \rightarrow +\infty$

We derive the equations for optimal estimator using similar arguments used for the standard Kalman filtering equations. The innovation step is given by:

$$\begin{aligned} \hat{x}_{k+1|k} &\triangleq \mathbb{E}[x_{k+1} | \nu_k, \mathcal{I}_k] = \mathbb{E}[Ax_k + \nu_k B u_k + w_k | \nu_k, \mathcal{I}_k] \\ &= A \mathbb{E}[x_k | \mathcal{I}_k] + \nu_k B u_k \\ &= A \hat{x}_{k|k} + \nu_k B u_k \end{aligned} \quad (9)$$

$$\begin{aligned} e_{k+1|k} &\triangleq x_{k+1} - \hat{x}_{k+1|k} \\ &= Ax_k + \nu_k B u_k + w_k - (A \hat{x}_{k|k} + \nu_k B u_k) \\ &= A e_{k|k} + w_k \end{aligned} \quad (10)$$

$$\begin{aligned} P_{k+1|k} &\triangleq \mathbb{E}[e_{k+1|k} e'_{k+1|k} | \nu_k, \mathcal{I}_k] = \\ &= \mathbb{E}[(A e_{k|k} + w_k) (A e_{k|k} + w_k)' | \nu_k, \mathcal{I}_k] \\ &= A \mathbb{E}[e_{k|k} e'_{k|k} | \mathcal{I}_k] A' + \mathbb{E}[w_k w'_k] \\ &= A P_{k|k} A' + Q \end{aligned} \quad (11)$$

where we used the independence of w_k and \mathcal{I}_k . Since y_{k+1} , γ_{k+1} , w_k and \mathcal{I}_k are all independent of each other and

following the same approach described in [3], the correction step is given by:

$$\hat{x}_{k+1|k+1} = \hat{x}_{k+1|k} + \gamma_{k+1} K_{k+1} (y_{k+1} - C \hat{x}_{k+1|k}) \quad (12)$$

$$\begin{aligned} e_{k+1|k+1} &= x_{k+1} - \hat{x}_{k+1|k+1} \\ &= x_{k+1} - (\hat{x}_{k+1|k} + \gamma_{k+1} K_{k+1} (y_{k+1} - C \hat{x}_{k+1|k})) \\ &= e_{k+1|k} - \gamma_{k+1} K_{k+1} (C x_{k+1} + v_{k+1} - C \hat{x}_{k+1|k}) \\ &= (I - \gamma_{k+1} K_{k+1} C) e_{k+1|k} - \gamma_{k+1} K_{k+1} v_{k+1} \\ P_{k+1|k+1} &= P_{k+1|k} - \gamma_{k+1} K_{k+1} C P_{k+1|k}, \end{aligned} \quad (13)$$

$$K_{k+1} \triangleq P_{k+1|k} C' (C P_{k+1|k} C' + R)^{-1}, \quad (14)$$

where we took the limit $\sigma \rightarrow +\infty$.

The initial conditions for the estimator iterative equations are:

$$\hat{x}_{0|-1} = 0 \quad (15)$$

$$P_{0|-1} = P_0 \quad (16)$$

B. Controller design

To derive the optimal feedback control law and the corresponding value for the objective function we will follow the dynamic programming approach based on the cost-to-go iterative procedure.

Define the optimal value function $V_k(x_k)$ as follows:

$$V_N(x_N) \triangleq \mathbb{E}[x'_N W_N x_N | \mathcal{I}_N]$$

$$V_k(x_k) \triangleq \min_{u_k} \mathbb{E}[x'_k W_k x_k + \nu_k u'_k U_k u_k + V_{k+1}(x_{k+1}) | \mathcal{I}_k]$$

Using dynamic programming theory [11] [12], one can show that $J_N^* = V_0(x_0)$.

We claim that the value function $V_k(x_k)$ can be written as:

$$V_k(x_k) = \mathbb{E}[x'_k S_k x_k | \mathcal{F}_k] + c_k, \quad k = 0, \dots, N \quad (17)$$

where the matrix S_k and the scalar c_k are to be determined and are independent of the information set \mathcal{I} . We will prove it by induction. The claim is certainly true for $k = N$ with the following choice of parameters:

$$S_N = W_N \quad (18)$$

$$c_N = 0 \quad (19)$$

Suppose now that the claim is true for $k + 1$, i.e. $V_{k+1}(x_{k+1}) = \mathbb{E}[x'_{k+1} S_{k+1} x_{k+1} | \mathcal{F}_{k+1}] + c_{k+1}$, and we use it to compute the value function at time step k as follows:

$$\begin{aligned} V_k(x_k) &= \min_{u_k} \mathbb{E}[x'_k W_k x_k + \nu_k u'_k U_k u_k + V_{k+1}(x_{k+1}) | \mathcal{I}_k] \\ &= \min_{u_k} \mathbb{E}[x'_k W_k x_k + \nu_k u'_k U_k u_k + \\ &+ \mathbb{E}[x'_{k+1} S_{k+1} x_{k+1} + c_{k+1} | \mathcal{F}_{k+1}] | \mathcal{I}_k] \\ &= \min_{u_k} \mathbb{E}[x'_k W_k x_k + \nu_k u'_k U_k u_k + x'_{k+1} S_{k+1} x_{k+1} + \\ &+ c_{k+1} | \mathcal{I}_k] \\ &= \mathbb{E}[x'_k W_k x_k + x'_k A' S_{k+1} A x_k | \mathcal{I}_k] + \\ &+ \text{trace}(S_{k+1} Q) + \mathbb{E}[c_{k+1} | \mathcal{I}_k] + \\ &+ \bar{\nu} \min_{u_k} (u'_k (U_k + B' S_{k+1} B) u_k + \\ &+ 2u'_k B' S_{k+1} A \hat{x}_{k|k}) \end{aligned} \quad (20)$$

where we used Lemma 1(c) in the third line, and Equation (7) in the last two lines. The value function is a quadratic function of the input, therefore the minimizer can be simply obtained by solving $\frac{\partial V_k}{\partial u_k} = 0$, which gives:

$$u_k = -(B'S_{k+1}B + U_k)^{-1}B'S_{k+1}A\hat{x}_{k|k} = L_k\hat{x}_{k|k}. \quad (21)$$

The optimal feedback is thus a simple linear feedback of the estimated state. If we substitute the minimizer back into Equation (20), and we use the Equation (17) we get:

$$\begin{aligned} V_k(x_k) &= \mathbb{E}[x_k'W_kx_k + x_k'A'S_{k+1}Ax_k | \mathcal{I}_k] + \\ &+ \text{trace}(S_{k+1}Q) + \mathbb{E}[c_{k+1} | \mathcal{I}_k] + \\ &- \bar{\nu}\hat{x}_{k|k}'A'S_{k+1}B(U_k + B'S_{k+1}B)^{-1}B'S_{k+1}A\hat{x}_{k|k} \end{aligned} \quad (22)$$

$$\begin{aligned} &\mathbb{E}[x_k'S_kx_k | \mathcal{I}_k] + c_k = \\ &= \mathbb{E}[x_k'W_kx_k + x_k'A'S_{k+1}Ax_k - \\ &+ \bar{\nu}x_k'A'S_{k+1}B(U_k + B'S_{k+1}B)^{-1}B'S_{k+1}Ax_k | \mathcal{I}_k] + \\ &+ \text{trace}(S_{k+1}Q) + \mathbb{E}[c_{k+1} | \mathcal{I}_k] + \\ &+ \bar{\nu}\text{trace}(A'S_{k+1}B(U_k + B'S_{k+1}B)^{-1}B'S_{k+1}P_{k|k}) \end{aligned} \quad (23)$$

where we used Lemma 1(b) in the last line. For the previous equation to hold for all x_k , we need to have:

$$\begin{aligned} S_k &= A'S_{k+1}A + W_k - \\ &+ \bar{\nu}A'S_{k+1}B(B'S_{k+1}B + U_k)^{-1}B'S_{k+1}A \quad (24) \\ c_k &= \bar{\nu}\text{trace}(A'S_{k+1}B(U_k + B'S_{k+1}B)^{-1}B'S_{k+1}P_{k|k}) + \\ &+ \text{trace}(S_{k+1}Q) + \mathbb{E}[c_{k+1} | \mathcal{I}_k] \\ &= \text{trace}((A'S_{k+1}A + W_k - S_k)P_{k|k}) + \\ &+ \text{trace}(S_{k+1}Q) + \mathbb{E}[c_{k+1} | \mathcal{I}_k] \end{aligned} \quad (25)$$

Therefore, the cost function for the optimal LQG using TCP is given by:

$$\begin{aligned} J_N^* &= V_0(x_0) = \mathbb{E}[x_0'S_0x_0] + \\ &+ \sum_{k=0}^{N-1} (\text{trace}((A'S_{k+1}A + W_k - S_k)\mathbb{E}_\gamma[P_{k|k}]) + \\ &+ \text{trace}(S_{k+1}Q)) \\ &= \bar{x}_0'S_0\bar{x}_0 + \text{trace}(S_0P_0) + \\ &+ \sum_{k=0}^{N-1} (\text{trace}((A'S_{k+1}A + W_k - S_k)\mathbb{E}_\gamma[P_{k|k}]) + \\ &+ \text{trace}(S_{k+1}Q)) \end{aligned} \quad (26)$$

The matrices $\{P_{k|k}\}_{k=0}^N$ are stochastic since they are function of the sequence $\{\gamma_k\}$. The exact expected value of these matrices cannot be computed analytically, since they are nonlinear function of the arrival sequence γ_k , as shown in [3]. However, they can be bounded by computable deterministic quantities. In fact let us consider the following

equation:

$$\begin{aligned} \hat{P}_{k+1|k} &= A\hat{P}_{k|k-1}A' + Q + \\ &- \bar{\gamma}A\hat{P}_{k|k-1}C'(C\hat{P}_{k|k-1}C' + R)^{-1} \\ &C\hat{P}_{k|k-1}A' \end{aligned} \quad (27)$$

$$\begin{aligned} \hat{P}_{k|k} &= \hat{P}_{k|k-1} - \bar{\gamma}\hat{P}_{k|k-1}C'(C\hat{P}_{k|k-1}C' + R)^{-1} \\ &C\hat{P}_{k|k-1} \end{aligned} \quad (28)$$

$$\tilde{P}_{k+1|k} = (1 - \bar{\gamma})A\tilde{P}_{k|k-1}A' + Q \quad (29)$$

$$\tilde{P}_{k|k} = (1 - \bar{\gamma})\tilde{P}_{k|k-1} \quad (30)$$

initialized to $\hat{P}_{0|-1} = \tilde{P}_{0|-1} = P_0$. Using similar arguments as those in [3], it is possible to show that the matrices $P_{k|k}$'s are concave and monotonic functions of $P_{k|k-1}$, respectively. Therefore, the following bounds are true:

$$\tilde{P}_{k|k} \leq \mathbb{E}_\gamma[P_{k|k}] \leq \hat{P}_{k|k}, \quad (31)$$

$$(32)$$

and we have:

$$J_N^{min} \leq J_N^* \leq J_N^{max} \quad (33)$$

$$\begin{aligned} J_N^{max} &= \bar{x}_0'S_0\bar{x}_0 + \text{trace}(S_0P_0) + \\ &+ \sum_{k=0}^{N-1} (\text{trace}((A'S_{k+1}A + W_k - S_k)\hat{P}_{k|k}) + \\ &+ \text{trace}(S_{k+1}Q)) \end{aligned} \quad (34)$$

$$\begin{aligned} J_N^{min} &= \bar{x}_0'S_0\bar{x}_0 + \text{trace}(S_0P_0) + \\ &+ \sum_{k=0}^{N-1} (\text{trace}((A'S_{k+1}A + W_k - S_k)\tilde{P}_{k|k}) + \\ &+ \text{trace}(S_{k+1}Q)) \end{aligned} \quad (35)$$

C. Finite and Infinite Horizon LQG control

The previous equations were derived for the finite horizon LQG. The infinite horizon LQG can be obtained by taking the limit for $N \rightarrow +\infty$ of the previous equations. However the minimal cost J_N is a stochastic function and does not have a limit. Differently from standard LQG controller design where the controller always stabilizes the original system, in the case control packet loss, the stability can be lost if the arrival probability $\bar{\nu}, \bar{\gamma}$ is below a certain threshold. In particular the Equation for the cost matrix S_k is the solution of a modified Riccati Algebraic Equation (MARE) which was already introduced and studied in our previous work [3]. In particular, Equation (24) is the dual of the estimator equation presented in [3]. Therefore, the same conclusions can be drawn and we are now ready summarize the previous result in the following theorem:

Theorem 1 (Finite Horizon LQG under TCP). *Consider the system (1)-(2) and consider the problem of minimizing the cost function (4) with policy $u_k = f(\mathcal{I}_k)$, where \mathcal{I}_k is the information available under TCP communication, given in Equation (3). Then, the optimal control is a **linear** function of the estimated system state given by Equation (21), where the matrix S_k can be computed iteratively*

using Equation (24). The **separation principle** still holds under TCP communication, since the optimal estimator is independent of the control input u_k . The optimal state estimator is given by Equations (9)-(12) and (11)-(14), and the minimal achievable cost is given by Equation (26).

Theorem 2 (Infinite Horizon LQG under TCP). Consider the same systems as defined in the previous theorem with the following additional hypothesis: $W_N = W_k = W$ and $U_k = U$. Moreover, let (A, B) and $(A, Q^{\frac{1}{2}})$ be controllable, and let (A, C) and $(A, W^{\frac{1}{2}})$ be observable. Let us consider the limiting case $N \rightarrow +\infty$, then, there exist arrival probabilities ν_{min} and γ_{min} which satisfy the following property:

$$\min \left(1, 1 - \frac{1}{|\lambda_{max}(A)|^2} \right) \leq \nu_{min} \leq 1, \quad (36)$$

$$\min \left(1, 1 - \frac{1}{|\lambda_{max}(A)|^2} \right) \leq \gamma_{min} \leq 1, \quad (37)$$

where $|\lambda_{max}(A)|$ is the eigenvalue of matrix A with largest absolute value, such that for all $\bar{\gamma} > \gamma_{min}$ we have:

$$L_k = L_\infty = -(B'S_\infty B + U)^{-1} B'S_\infty A \quad (38)$$

$$\frac{1}{N} J_N^{min} \leq \frac{1}{N} J_N^* \leq \frac{1}{N} J_N^{max} \quad (39)$$

where the mean cost bounds J_∞^{min} , J_∞^{max} are given by:

$$\begin{aligned} J_\infty^{max} &= \lim_{N \rightarrow +\infty} \frac{1}{N} J_N^{max} \\ &= \text{trace}((A'S_\infty A + W_k - S_\infty)(\hat{P}_\infty + \\ &\quad - \bar{\gamma} \hat{P}_\infty C'(C\hat{P}_\infty C' + R)^{-1} C\hat{P}_\infty)) + \text{trace}(S_\infty Q) \\ J_\infty^{min} &= \lim_{N \rightarrow +\infty} \frac{1}{N} J_N^{min} \\ &= (1 - \bar{\gamma}) \text{trace}((A'S_\infty A + W_k - S_\infty)\tilde{P}_\infty) + \\ &\quad + \text{trace}(S_\infty Q) \end{aligned}$$

and the matrices $S_\infty, \bar{P}_\infty, P_\infty$

$$\begin{aligned} S_\infty &= A'S_\infty A + W - \bar{\nu} A'S_\infty B(B'S_\infty B + U)^{-1} B'S_\infty A \\ \bar{P}_\infty &= A\bar{P}_\infty A' + Q - \bar{\gamma} A\bar{P}_\infty C'(C\bar{P}_\infty C' + R)^{-1} C\bar{P}_\infty A' \\ P_\infty &= (1 - \bar{\gamma})AP_\infty A' + Q \end{aligned}$$

Moreover, the assumptions above are **necessary and sufficient** conditions for boundedness of cost function under LQG feedback. The critical probabilities γ_{min} and ν_{min} can be computed via the solution of the following LMIs optimization problems:

$$\gamma_{min} = \arg\min_{\bar{\gamma}} \Psi_\gamma(Y, Z) > 0, \quad 0 \leq Y \leq I.$$

$$\Psi_\gamma(Y, Z) = \begin{bmatrix} Y & \sqrt{\gamma}(YA + ZC) & \sqrt{1-\gamma}YA \\ \sqrt{\gamma}(A'Y + C'Z') & Y & 0 \\ \sqrt{1-\gamma}A'Y & 0 & Y \end{bmatrix}$$

$$\nu_{min} = \arg\min_{\bar{\nu}} \Psi_\nu(Y, Z) > 0, \quad 0 \leq Y \leq I.$$

$$\Psi_\nu(Y, Z) = \begin{bmatrix} Y & \sqrt{\nu}(YA' + ZB') & \sqrt{1-\nu}YA' \\ \sqrt{\nu}(AY + BZ') & Y & 0 \\ \sqrt{1-\nu}AY & 0 & Y \end{bmatrix}$$

V. CONCLUSION

Motivated by applications where control is performed over a communication network, in this paper we extend our previous results on optimal control with intermittent observations to the case where control packets may be lost due to the presence of an unreliable communication channel between the controller and the actuator. We assume that an acknowledgement of the arrival of the control packet is always available to the controller (TCP). First, we showed that the separation principle holds also in this case. Then we proved that the optimal LQG control is a linear function of the state. Finally, by providing analytic upper and lower bounds on the cost functional we could show the existence of critical arrival probabilities below which the optimal controller fails to stabilize the system. Future work will involve the analysis for the case when the controller does not receive any acknowledgement to whether its packet has been received by the actuator or not.

VI. ACKNOWLEDGEMENT

This research was partially supported by the Defense Advanced Research Projects Agency under Grant F33615-01-C-1895, and by the European Community Research Information Society Technologies under Grant No. RECSYS IST-2001-32515.

REFERENCES

- [1] B. Sinopoli, C. Sharp, S. Schaffert, L. Schenato, and S. Sastry, "Distributed control applications within sensor networks," *Proceedings of the IEEE, Special Issue on Distributed Sensor Networks*, vol. 91, no. 8, pp. 1235-1246, August 2003.
- [2] B. Sinopoli, L. Schenato, M. Franceschetti, K. Poolla, and S. Sastry, "Time varying optimal control with packet losses," in *IEEE Conference on Decision and Control*, December 2004.
- [3] B. Sinopoli, L. Schenato, M. Franceschetti, K. Poolla, M. Jordan, and S. Sastry, "Kalman filtering with intermittent observations," *IEEE Transactions on Automatic Control*, vol. 49, no. 9, pp. 1453-1464, September 2004.
- [4] —, "Kalman filtering with intermittent observations," in *IEEE Conference on Decision and Control*, December 2003.
- [5] Q. Ling and M. Lemmon, "Optimal dropout compensation in networked control systems," in *IEEE conference on decision and control*, Maui, HI, December 2003.
- [6] V. Gupta, D. Spanos, B. Hassibi, and R. M. Murray, "Optimal lqg control across a packet-dropping link," California Institute of technology, Tech. Rep., 2004, preprint, submitted for publication.
- [7] O. C. Imer, S. Yuksel, and T. Basar, "Optimal control of dynamical systems over unreliable communication links," in *NOLCOS*, Stuttgart, Germany, 2004.
- [8] J. Nilsson, "Real-time control systems with delays," Ph.D. dissertation, Department of Automatic Control, Lund Institute of Technology, 1998.
- [9] C. N. Hadjicostis and R. Touri, "Feedback control utilizing packet dropping network links," in *Proceedings of the 41st IEEE Conference on Decision and Control*, Las Vegas, NV, Dec 2002, invited.
- [10] Q. Ling and M. Lemmon, "Soft real-time scheduling of networked control systems with dropouts governed by a markov chain," in *American Control Conference*, Denver, CO, June 2003.

- [11] P. Kumar and P. Varaiya, *Stochastic Systems: Estimation, Identification and Adaptive Control*, ser. Information and System Science Series, T. Kailath, Ed. Englewood Cliffs, NJ 07632: Prentice Hall, 1986.
- [12] D. Bertsekas and J. Tsitsiklis, *Neuro-Dynamic Programming*. Athena Scientific, September 1996.