

# Optimal portfolio liquidation with execution cost and risk\*

Idris KHARROUBI

Laboratoire de Probabilités et  
Modèles Aléatoires  
CNRS, UMR 7599  
Université Paris 7,  
and CREST,  
e-mail: kharroubi@ensae.fr

Huyên PHAM

Laboratoire de Probabilités et  
Modèles Aléatoires  
CNRS, UMR 7599  
Université Paris 7,  
CREST, and  
Institut Universitaire de France  
e-mail: pham@math.jussieu.fr

This revised version: June 2010

## Abstract

We study the optimal portfolio liquidation problem over a finite horizon in a limit order book with bid-ask spread and temporary market price impact penalizing speedy execution trades. We use a continuous-time modeling framework, but in contrast with previous related papers (see e.g. [28] and [29]), we do not assume continuous-time trading strategies. We consider instead real trading that occur in discrete-time, and this is formulated as an impulse control problem under a solvency constraint, including the lag variable tracking the time interval between trades. A first important result of our paper is to prove rigorously that nearly optimal execution strategies in this context lead actually to a finite number of trades with strictly increasing trading times, and this holds true without assuming ad hoc any fixed transaction fee. Next, we derive the dynamic programming quasi-variational inequality satisfied by the value function in the sense of constrained viscosity solutions. We also introduce a family of value functions converging to our value function, and which is characterized as the unique constrained viscosity solutions of an approximation of our dynamic programming equation. This convergence result is useful for numerical purpose, postponed in a companion paper [15].

**Keywords:** Optimal portfolio liquidation, execution trade, liquidity effects, order book, impulse control, viscosity solutions.

**MSC Classification (2000) :** 93E20, 91B28, 60H30, 49L25.

---

\*We would like to thank Bruno Bouchard for useful comments. We also thank participants at the *Istanbul workshop on Mathematical Finance* in may 2009, for relevant remarks. The comments of two anonymous referees are helpful to improve the first version of this paper.

# 1 Introduction

Understanding trade execution strategies is a key issue for financial market practitioners, and has attracted a growing attention from the academic researchers. An important problem faced by stock traders is how to liquidate large block orders of shares. This is a challenge due to the following dilemma. By trading quickly, the investor is subject to higher costs due to market impact reflecting the depth of the limit order book. Thus, to minimize price impact, it is generally beneficial to break up a large order into smaller blocks. However, more gradual trading over time results in higher risks since the asset value can vary more during the investment horizon in an uncertain environment. There has been recently a considerable interest in the literature on such liquidity effects, taking into account permanent and/or temporary price impact, and problems of this type were studied in [7], [1], [5], [9], [22], [16], [29], [20], [28], and [10], to mention some of them.

There are essentially two popular formulation types for the optimal trading problem in the literature: discrete-time versus continuous-time. In the discrete-time formulation, we may distinguish papers considering that trading take place at fixed deterministic times (see [7]), at exogenous random discrete times given for example by the jumps of a Poisson process (see [26], [6]), or at discrete times decided optimally by the investor through an impulse control formulation (see [16] and [20]). In this last case, one usually assumes the existence of a fixed transaction cost paid at each trading in order to ensure that strategies do not accumulate in time and occur really at discrete points in time (see e.g. [18] or [23]). The continuous-time trading formulation is not realistic in practice, but is commonly used (as in [9], [29] or [28]), due to the tractability and powerful theory of the stochastic calculus typically illustrated by Itô's formula. In a perfectly liquid market without transaction cost and market impact, continuous-time trading is often justified by arguing that it is a limit approximation of discrete-time trading when the time step goes to zero. However, one may question the validity of such assertion in the presence of liquidity effects.

In this paper, we propose a continuous-time framework taking into account the main liquidity features and risk/cost tradeoff of portfolio execution: there is a bid-ask spread in the limit order book, and temporary market price impact penalizing rapid execution trades. However, in contrast with previous related papers ([29] or [28]), we do not assume continuous-time trading strategies. We consider instead real trading that take place in discrete-time, and without assuming ad hoc any fixed transaction cost, in accordance with the practitioner literature. Moreover, a key issue in line of the banking regulation and solvency constraints is to define in an economically meaningful way the portfolio value of a position in stock at any time, and this is addressed in our modelling. These issues are formulated conveniently through an impulse control problem including the lag variable tracking the time interval between trades. Thus, we combine the advantages of the stochastic calculus techniques, and the realistic modeling of portfolio liquidation. In this context, we study the optimal portfolio liquidation problem over a finite horizon: the investor seeks to unwind an initial position in stock shares by maximizing his expected utility from terminal liquidation wealth, and under a natural economic solvency constraint involving the liquidation value of a portfolio.

A first important result of our paper is to show that that nearly optimal execution strategies in this modeling lead actually to a finite number of trading times. Actually, most models dealing with trading strategies via an impulse control formulation assumed a priori that admissible trades occur only finitely many times (see e.g. [21]), or required fixed transaction cost in order to justify a posteriori the discrete-nature of trading times. In this paper, we prove that discrete-time trading appear endogenously as a consequence of liquidity features represented by temporary price impact and bid-ask spread. Moreover, the optimal trading times are strictly increasing. To the best of our knowledge, the rigorous proof of these properties are new. Next, we derive the dynamic programming quasi-variational inequality (QVI) satisfied by the value function in the sense of constrained viscosity solutions in order to handle state constraints. There are some technical difficulties related to the nonlinearity of the impulse transaction function induced by the market price impact, and the non smoothness of the solvency boundary. In particular, since we do not assume a fixed transaction fee, which precludes the existence of a strict supersolution to the QVI, we can not prove directly a comparison principle (hence a uniqueness result) for the QVI. However, by using a utility penalization method with small costs, we can prove that the value function is characterized as the minimal viscosity solution to its QVI. We next consider an approximation problem with fixed small transaction costs, and whose associated value functions are characterized as unique constrained viscosity solutions to their dynamic programming equations. We then prove the convergence of these value functions to our original value function by relying on the finiteness of the number of trading strategies. This convergence result is new and useful for numerical purpose, postponed in a further study.

The plan of the paper is organized as follows. Section 2 presents the details of the model and formulates the liquidation problem. In Section 3, we show some interesting economical and mathematical properties of the model, in particular the finiteness of the number of trading strategies under illiquidity costs. Section 4 is devoted to the dynamic programming and viscosity properties of the value function to our impulse control problem. We prove in particular that our value function is characterized as the minimal constrained viscosity solution to its dynamic programming QVI. We propose in Section 5 an approximation of the original problem by considering small fixed transaction fee.

## 2 The model and liquidation problem

We consider a financial market where an investor has to liquidate an initial position of  $y > 0$  shares of risky asset (or stock) by time  $T$ . He faces with the following risk/cost tradeoff: if he trades rapidly, this results in higher costs for quickly executed orders and market price impact; he can then split the order into several smaller blocks, but is then exposed to the risk of price depreciation during the trading horizon. These liquidity effects received recently a considerable interest starting with the papers [7], and [1] in a discrete-time framework, and further investigated among others in [22], [29], or [28] in a continuous-time model. These papers assume continuous trading with instantaneous trading rate inducing price impact. In a continuous time market framework, we propose here a more realistic modeling by

considering that trading takes place at discrete points in time through an impulse control formulation, and with a temporary price impact depending on the time interval between trades, and including a bid-ask spread.

We present the details of the model. Let  $(\Omega, \mathcal{F}, \mathbb{P})$  be a probability space equipped with a filtration  $\mathbb{F} = (\mathcal{F}_t)_{0 \leq t \leq T}$  satisfying the usual conditions, and supporting a one dimensional Brownian motion  $W$  on a finite horizon  $[0, T]$ ,  $T < \infty$ . We denote by  $P_t$  the market price of the risky asset, by  $X_t$  the amount of money (or cash holdings), by  $Y_t$  the number of shares in the stock held by the investor at time  $t$ , and by  $\Theta_t$  the time interval between time  $t$  and the last trade before  $t$ . We set  $\mathbb{R}^* = \mathbb{R} \setminus \{0\}$ ,  $\mathbb{R}_+^* = (0, \infty)$  and  $\mathbb{R}_-^* = (-\infty, 0)$ .

- *Trading strategies.* We assume that the investor can only trade discretely on  $[0, T]$ . This is modelled through an impulse control strategy  $\alpha = (\tau_n, \zeta_n)_{n \geq 0}$ :  $\tau_0 \leq \dots \leq \tau_n \dots \leq T$  are nondecreasing stopping times representing the trading times of the investor and  $\zeta_n$ ,  $n \geq 0$ , are  $\mathcal{F}_{\tau_n}$ -measurable random variables valued in  $\mathbb{R}$  and giving the number of stock purchased if  $\zeta_n \geq 0$  or sold if  $\zeta_n < 0$  at these times. We denote by  $\mathcal{A}$  the set of trading strategies. The sequence  $(\tau_n, \zeta_n)$  may be a priori finite or infinite. Notice also that we do not assume a priori that the sequence of trading times  $(\tau_n)$  is strictly increasing. We introduce the lag variable tracking the time interval between trades:

$$\Theta_t = \inf \{t - \tau_n : \tau_n \leq t\}, \quad t \in [0, T],$$

which evolves according to

$$\Theta_t = t - \tau_n, \quad \tau_n \leq t < \tau_{n+1}, \quad \Theta_{\tau_{n+1}} = 0, \quad n \geq 0. \quad (2.1)$$

The dynamics of the number of shares invested in stock is given by:

$$Y_t = Y_{\tau_n}, \quad \tau_n \leq t < \tau_{n+1}, \quad Y_{\tau_{n+1}} = Y_{\tau_{n+1}^-} + \zeta_{n+1}, \quad n \geq 0. \quad (2.2)$$

- *Cost of illiquidity.* The market price of the risky asset process follows a geometric Brownian motion:

$$dP_t = P_t(bdt + \sigma dW_t), \quad (2.3)$$

with constants  $b$  and  $\sigma > 0$ . We do not consider a permanent price impact on the price, i.e. the lasting effect of large trader, but focus here on the effect of illiquidity, that is the price at which an investor will trade the asset. Suppose now that the investor decides at time  $t$  to make an order in stock shares of size  $e$ . If the current market price is  $p$ , and the time lag from the last order is  $\theta$ , then the price he actually get for the order  $e$  is:

$$Q(e, p, \theta) = pf(e, \theta), \quad (2.4)$$

where  $f$  is a temporary price impact function from  $\mathbb{R} \times [0, T]$  into  $\mathbb{R}_+ \cup \{\infty\}$ . The impact of liquidity modelled in (2.4) is like a transaction cost combining nonlinearity and proportionality effects. The nonlinear costs come from the dependence of the function  $f$  on  $e$  and  $\theta$ , and we assume the natural condition:

**(H1)**  $f(0, \theta) = 1$ , and  $f(\cdot, \theta)$  is nondecreasing for all  $\theta \in [0, T]$ .

Condition **(H1)** means that no trade incurs no impact on the market price, i.e.  $Q(0, p, \theta) = p$ , and a purchase (resp. a sale) of stock shares induces a cost (resp. gain) greater (resp. smaller) than the market price, which increases (resp. decreases) with the size of the order. In other words, we have  $Q(e, p, \theta) \geq$  (resp.  $\leq$ )  $p$  for  $e \geq$  (resp.  $\leq$ )  $0$ , and  $Q(\cdot, p, \theta)$  is nondecreasing. The proportional transaction costs effect is realized by considering a bid-ask spread, i.e. assuming the following condition:

$$\begin{aligned} \text{(H2)} \quad \overline{\kappa_b} &:= \sup_{\theta \in [0, T]} \kappa_b(\theta) := \sup_{\theta \in [0, T]} f(0^-, \theta) < 1, \text{ and} \\ \underline{\kappa_a} &:= \inf_{\theta \in [0, T]} \kappa_a(\theta) := \inf_{\theta \in [0, T]} f(0^+, \theta) > 1. \end{aligned}$$

The term  $\kappa_b(\theta)$  (resp.  $\kappa_a(\theta)$ ) may be interpreted as the relative bid price (resp. ask price) given a time lag from last order  $\theta$ , and condition **(H2)** means that, given a current market or mid price  $p$  at time  $t$ ,  $\overline{\kappa_b}p$  is the largest bid price,  $\underline{\kappa_a}p$  is the lowest ask price, and  $(\underline{\kappa_a} - \overline{\kappa_b})p$  is the bid-ask spread. In typical example (see (2.6)),  $\kappa_a(\theta)$  and  $\kappa_b(\theta)$  does not depend on  $\theta$ , i.e.  $\kappa_a(\theta) = \underline{\kappa_a}$ , and  $\kappa_b(\theta) = \overline{\kappa_b}$ . On the other hand, this transaction cost function  $f$  can be determined implicitly from the impact of a market order placed by a large trader in a limit order book, as explained in [22], [29] or [28]. Indeed, suppose that there is some mid price  $p$  at current time  $t$ , and an order book of quotes posted either side of the mid price. To fix the ideas, we consider the upperhalf of the limit order book (LOB), and we denote by  $\rho_a(k, \theta)$  the density of quotes to sell at relative price  $k \geq \kappa_a(\theta)$ , when the time lag from the last market order of the large trader is  $\theta$ . Similarly as in [22] or [12], we considered that the LOB may be affected by the past trades of the large investor through e.g. its last trading time. If the large investor places a buy market order for  $e > 0$  shares of the asset, this will consume all shares in the LOB located at relative prices between  $\kappa_a(\theta)$  and  $\hat{k} = \hat{k}(e, \theta)$  determined by

$$\int_{\kappa_a(\theta)}^{\hat{k}} \rho_a(k, \theta) dk = e.$$

Consequently, the cost paid by the large investor to acquire  $e > 0$  units of the asset through the LOB is

$$Q(p, e, \theta) = p \int_{\kappa_a(\theta)}^{\hat{k}} k \rho_a(k, \theta) dk = pf(e, \theta). \quad (2.5)$$

Therefore, the shape function  $\rho_a$  of the LOB for sell quotes determines via the relation (2.5) the temporary market impact function  $f$  for buy market order. Similarly, the shape function  $\rho_b$  of the LOB for buy quotes determines the price impact function  $f$  for sell market order, i.e.  $f(e, \cdot)$  for  $e < 0$ . Notice in particular that the dependence of  $f$  in  $\theta$  is induced by the dependence of  $\rho_a$  and  $\rho_b$  on  $\theta$ . Such an assumption is also made in the seminal paper [1], where the price impact function penalizes high trading volume per unit of time  $e/\theta$ . We assume that  $f$  satisfies:

$$\text{(H3)} \quad \text{(i) } f(e, 0) = 0 \text{ for } e < 0, \text{ and (ii) } f(e, 0) = \infty \text{ for } e > 0.$$

Condition **(H3)** expresses the higher costs for immediacy in trading: indeed, the immediate market resiliency is limited, and the faster the investor wants to liquidate (resp. purchase) the asset, the deeper into the limit order book he will have to go, and lower (resp. higher)

will be the price for the shares of the asset sold (resp. bought), with a zero (resp. infinite) limiting price for immediate block sale (resp. purchase). If the investor speeds up his buy trades, he will deplete the short-term supply and increase the immediate cost for additional trades. As more time is allowed between trades, supply will gradually recover. Moreover, the intervention of a large investor in an illiquid market has an important impact on the order book. His trading will execute the majority of orders on standby, and so clear out the order book. Condition **(H3)** also prevents the investor to pass orders at immediate consecutive times, which is the case in practice. Notice that if we consider a market impact function  $f(e)$ , which does not depend on  $\theta$ , then the strict increasing monotonicity of trading times is not guaranteed a priori by a fixed transaction fee  $\varepsilon > 0$ . Indeed, suppose for example that the investor wants to buy  $e$  shares of stock, given the current market price  $p$ . Then, in the case where  $e_1pf(e_1) + e_2pf(e_2) + \varepsilon < epf(e)$ , for some positive  $e_1, e_2$  s.t.  $e_1 + e_2 = e$ , it is better to split the number of shares, and trade separately the smaller quantities  $e_1$  and  $e_2$  at the same time.

We also assume some technical regularity conditions on the temporary price impact function, which shall be used later in Theorem 3.1.

- (H4)** (i)  $f$  is continuous on  $\mathbb{R}^* \times (0, T]$ ,  
(ii)  $f$  is  $C^1$  on  $\mathbb{R}_-^* \times [0, T]$  and  $x \mapsto \frac{\partial f}{\partial \theta}$  is bounded on  $\mathbb{R}_-^* \times [0, T]$ .

A usual form (see e.g. [19], [2]) of temporary price impact function  $f$  (which also includes here a transaction cost term as well), suggested by empirical studies is

$$f(e, \theta) = \exp\left(\lambda \left|\frac{e}{\theta}\right|^\beta \text{sgn}(e)\right) \cdot \left(\underline{\kappa}_a \mathbf{1}_{e>0} + \mathbf{1}_{e=0} + \overline{\kappa}_b \mathbf{1}_{e<0}\right), \quad (2.6)$$

with the convention  $f(0, 0) = 1$ . Here  $0 < \overline{\kappa}_b < 1 < \underline{\kappa}_a$ ,  $\underline{\kappa}_a - \overline{\kappa}_b$  is the (relative) the bid-ask spread parameter,  $\lambda > 0$  is the temporary price impact factor, and  $\beta > 0$  is the price impact exponent. The price impact function  $f$  depends on  $e$  and  $\theta$  through the volume per unit of time  $\vartheta = e/\theta$ , and the penalization of quick trading, i.e. when  $\theta$  goes to zero, is formulated by condition **(H3)**, which is satisfied in (2.6). The power functional form in  $e/\theta$  for the logarithm of the price impact function fits well with the statistical properties of order books (see [27]), and the parameters  $\lambda, \beta$  can be determined by regressions on data. In particular, empirical observations suggest a value  $\beta = 1/2$ . Notice that in the limiting case  $\lambda = 0$ , the function  $f$  is constant on  $(0, \infty)$  and  $(-\infty, 0)$ , with a jump at 0, which means that one ignores the nonlinear costs, keeping only the proportional costs.

In our illiquidity model, we focus on the cost of trading fast (that is the temporary price impact), and ignore as in [9] and [28] the permanent price impact of a large trade. This last effect could be included in our model, by assuming a jump of the price process at the trading date, depending on the order size, see e.g. [16] and [20].

• *Cash holdings.* We assume a zero risk-free return, so that the bank account is constant between two trading times:

$$X_t = X_{\tau_n}, \quad \tau_n \leq t < \tau_{n+1}, \quad n \geq 0. \quad (2.7)$$

When a discrete trading  $\Delta Y_t = \zeta_{n+1}$  occurs at time  $t = \tau_{n+1}$ , this results in a variation of the cash amount given by  $\Delta X_t := X_t - X_{t-} = -\Delta Y_t \cdot Q(\Delta Y_t, P_t, \Theta_{t-})$  due to the illiquidity

effects. In other words, we have

$$\begin{aligned} X_{\tau_{n+1}} &= X_{\tau_{n+1}^-} - \zeta_{n+1}Q(\zeta_{n+1}, P_{\tau_{n+1}}, \Theta_{\tau_{n+1}^-}) \\ &= X_{\tau_{n+1}^-} - \zeta_{n+1}P_{\tau_{n+1}}f(\zeta_{n+1}, \tau_{n+1} - \tau_n), \quad n \geq 0. \end{aligned} \quad (2.8)$$

Notice that similarly as in the above cited papers dealing with continuous-time trading, we do not assume fixed transaction fees to be paid at each trading. They are practically insignificant with respect to the price impact and bid-ask spread. We can then not exclude a priori trading strategies with immediate trading times, i.e.  $\Theta_{\tau_{n+1}^-} = \tau_{n+1} - \tau_n = 0$  for some  $n$ . However, notice that under condition **(H3)**, an immediate sale does not increase the cash holdings, i.e.  $X_{\tau_{n+1}} = X_{\tau_{n+1}^-} = X_{\tau_n}$ , while an immediate purchase leads to a bankruptcy, i.e.  $X_{\tau_{n+1}} = -\infty$ .

**Remark 2.1** Although assumption **(H3)** induces the worst gains for immediate successive trading, it does not prevent continuous-time trading at the limit. To see this, let us consider a market impact function  $f(e, \theta) = \bar{f}(e/\theta)$  depending on  $e, \theta$  through the volume per unit of time  $e/\theta$ , as in (2.6), and define the continuous-time (deterministic) strategy  $(Y_t)_t$  with constant slope starting from  $Y_0 = y > 0$ , and ending at  $Y_T = 0$  at the liquidation date  $T$ . Consider now a uniform time discretization of the interval  $[0, T]$  with time step  $h = T/N$ , and define the discrete-time strategy  $\alpha^h = (\tau_n^h, \zeta_n^h)_{1 \leq n \leq N}$  by

$$\tau_n^h = nh \quad \text{and} \quad \zeta_n^h = Y_{\tau_n^h} - Y_{\tau_{n-1}^h} = -\frac{y}{N}, \quad n \geq 1,$$

with  $\tau_0^h = 0$ . This strategy  $\alpha^h$  à la Almgren-Criss is a uniform discrete-time approximation of  $Y$ . From (2.8), the cash holdings associated to this strategy, and starting from an initial capital  $x$ , is then given at terminal date  $T$  by:

$$\begin{aligned} X_T^h &= x - \sum_{n=1}^N \zeta_n^h P_{\tau_n^h} \bar{f}\left(\frac{\zeta_n^h}{\tau_n^h - \tau_{n-1}^h}\right) \\ &= x + \sum_{n=1}^N \frac{y}{T} h P_{\tau_n^h} \bar{f}\left(-\frac{y}{T}\right) \longrightarrow x + \frac{y}{T} \bar{f}\left(-\frac{y}{T}\right) \int_0^T P_t dt, \end{aligned}$$

when  $h$  goes to zero. Thus, we see that the execution cost for the continuous-time limit strategy is also finite. Actually, the above argument shows more generally that any continuous-time finite variation strategy  $(Y_t)$  with continuous instantaneous trading rate process  $\eta_t = dY_t/dt$ , can be approximated by a discrete-time trading strategy  $\alpha^h = (\tau_n^h, \zeta_n^h)_{1 \leq n \leq N}$ , with  $\tau_n^h = nh$ ,  $\zeta_n^h = Y_{\tau_n^h} - Y_{\tau_{n-1}^h}$ , such that the corresponding execution cost  $X_T^h$  converges to  $x - \int_0^T P_t \bar{f}(\eta_t) dY_t$ , as  $h = T/N$  goes to zero.

- *Liquidation value and solvency constraint.* A key issue in portfolio liquidation is to define in an economically meaningful way what is the portfolio value of a position on cash and stocks. In our framework, we impose a no-short selling constraint on the trading strategies, i.e.

$$Y_t \geq 0, \quad 0 \leq t \leq T.$$

This constraint is consistent with the bank regulations following the financial crisis. We consider the liquidation function  $L(x, y, p, \theta)$  representing the net wealth value that an investor with a cash amount  $x$ , would obtained by liquidating his stock position  $y \geq 0$  by a single block trade, when the market price is  $p$  and given the time lag  $\theta$  from the last trade. It is defined on  $\mathbb{R} \times \mathbb{R}_+ \times \mathbb{R}_+^* \times [0, T]$  by

$$L(x, y, p, \theta) = x + ypf(-y, \theta),$$

and we impose the liquidation constraint on trading strategies:

$$L(X_t, Y_t, P_t, \Theta_t) \geq 0, \quad 0 \leq t \leq T.$$

We have  $L(x, 0, p, \theta) = x$ , and under condition **(H3)**(ii), we notice that  $L(x, y, p, 0) = x$  for  $y \geq 0$ . We naturally introduce the liquidation solvency region:

$$\mathcal{S} = \left\{ (z, \theta) = (x, y, p, \theta) \in \mathbb{R} \times \mathbb{R}_+ \times \mathbb{R}_+^* \times [0, T] : y > 0 \text{ and } L(z, \theta) > 0 \right\}.$$

We denote its boundary and its closure by

$$\partial \mathcal{S} = \partial_y \mathcal{S} \cup \partial_L \mathcal{S} \quad \text{and} \quad \bar{\mathcal{S}} = \mathcal{S} \cup \partial \mathcal{S},$$

where

$$\begin{aligned} \partial_y \mathcal{S} &= \left\{ (z, \theta) = (x, y, p, \theta) \in \mathbb{R} \times \mathbb{R}_+ \times \mathbb{R}_+^* \times [0, T] : y = 0 \text{ and } x = L(z, \theta) \geq 0 \right\}, \\ \partial_L \mathcal{S} &= \left\{ (z, \theta) = (x, y, p, \theta) \in \mathbb{R} \times \mathbb{R}_+ \times \mathbb{R}_+^* \times [0, T] : L(z, \theta) = 0 \right\}. \end{aligned}$$

We also denote by  $D_0$  the corner line in  $\partial \mathcal{S}$ :

$$D_0 = \{0\} \times \{0\} \times \mathbb{R}_+^* \times [0, T] = \partial_y \mathcal{S} \cap \partial_L \mathcal{S}.$$

We represent in Figure 1 the graph of  $\mathcal{S}$  in the plane  $(x, y)$ , in Figure 2 the graph of  $\mathcal{S}$  in the space  $(x, y, p)$ , and in Figure 3 the graph of  $\mathcal{S}$  in the space  $(x, y, \theta)$ .

- *Admissible trading strategies.* Given  $(t, z, \theta) \in [0, T] \times \bar{\mathcal{S}}$ , we say that the impulse control strategy  $\alpha = (\tau_n, \zeta_n)_{n \geq 0}$  is admissible, denoted by  $\alpha \in \mathcal{A}(t, z, \theta)$ , if  $\tau_0 = t - \theta$ ,  $\tau_n \geq t$ ,  $n \geq 1$ , and the process  $\{(Z_s, \Theta_s) = (X_s, Y_s, P_s, \Theta_s), t \leq s \leq T\}$  solution to (2.1)-(2.2)-(2.3)-(2.7)-(2.8), with an initial state  $(Z_{t-}, \Theta_{t-}) = (z, \theta)$  (and the convention that  $(Z_t, \Theta_t) = (z, \theta)$  if  $\tau_1 > t$ ), satisfies  $(Z_s, \Theta_s) \in [0, T] \times \bar{\mathcal{S}}$  for all  $s \in [t, T]$ . As usual, to alleviate notations, we omitted the dependence of  $(Z, \Theta)$  in  $(t, z, \theta, \alpha)$ , when there is no ambiguity.

- *Portfolio liquidation problem.* We consider a utility function  $U$  from  $\mathbb{R}_+$  into  $\mathbb{R}$ , nondecreasing, concave, with  $U(0) = 0$ , and s.t. there exists  $K \geq 0$  and  $\gamma \in [0, 1)$ :

$$\text{(H5)} \quad 0 \leq U(x) \leq Kx^\gamma, \quad \forall x \in \mathbb{R}_+.$$

The problem of optimal portfolio liquidation is formulated as

$$v(t, z, \theta) = \sup_{\alpha \in \mathcal{A}_\ell(t, z, \theta)} \mathbb{E}[U(X_T)], \quad (t, z, \theta) \in [0, T] \times \bar{\mathcal{S}}, \quad (2.9)$$



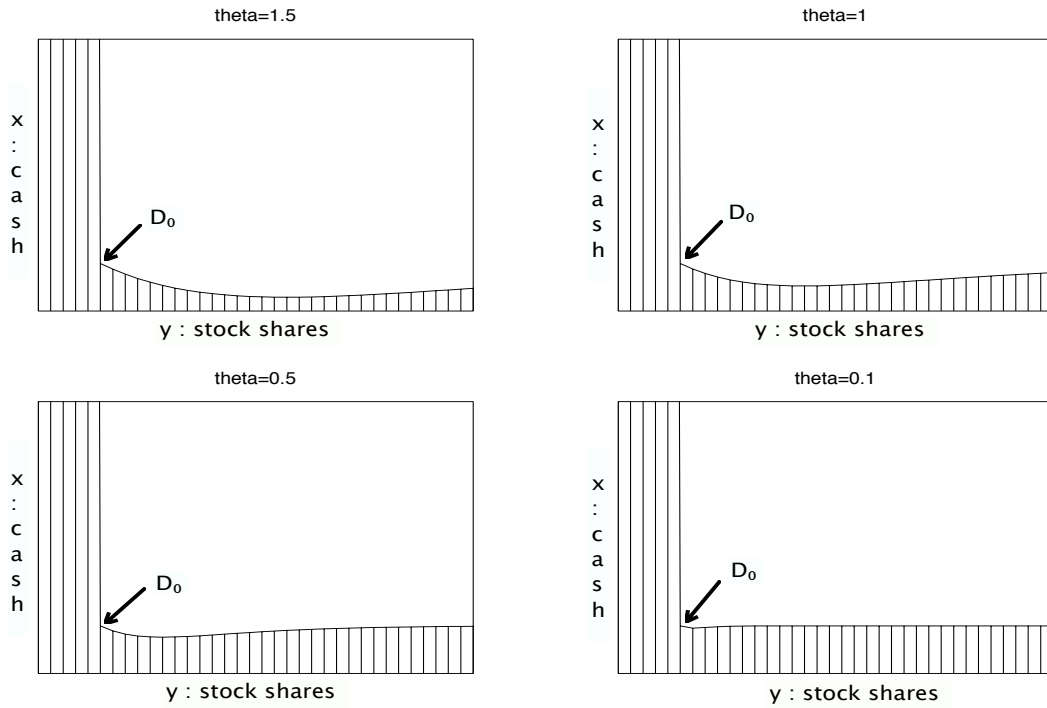

Figure 1: Domain  $\mathcal{S}$  in the nonhatched zone for fixed  $p = 1$  and  $\theta$  evolving from 1.5 to 0.1. Here  $\bar{\kappa}_b = 0.9$  and  $f(e, \theta) = \bar{\kappa}_b \exp(\frac{e}{\theta})$  for  $e < 0$ . Notice that when  $\theta$  goes to 0, the domain converges to the open orthant  $\mathbb{R}_+^* \times \mathbb{R}_+^*$ .

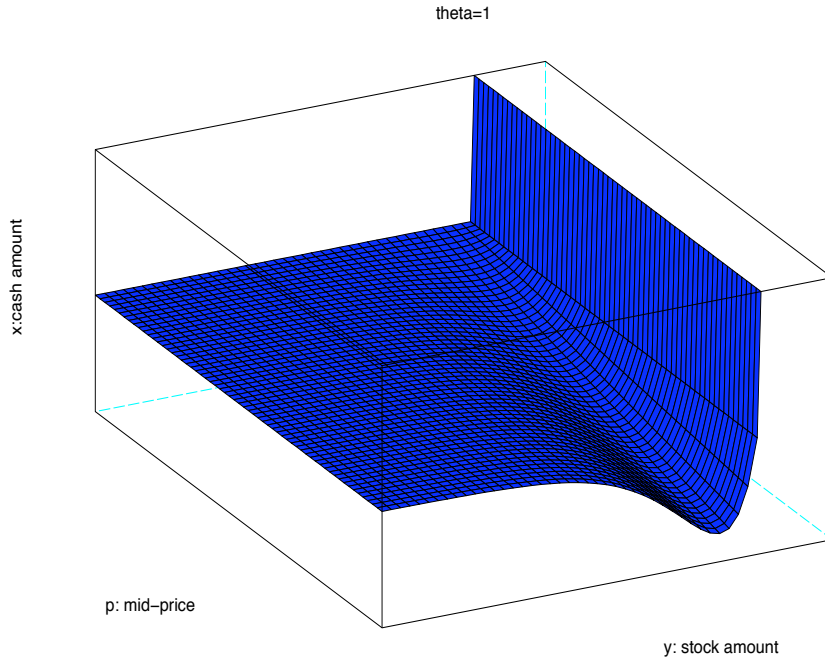

Figure 2: Lower bound of the domain  $\mathcal{S}$  for fixed  $\theta = 1$ . Here  $\bar{\kappa}_b = 0.9$  and  $f(e, \theta) = \bar{\kappa}_b \exp(\frac{e}{\theta})$  for  $e < 0$ . Notice that when  $p$  is fixed, we obtain the Figure 1.

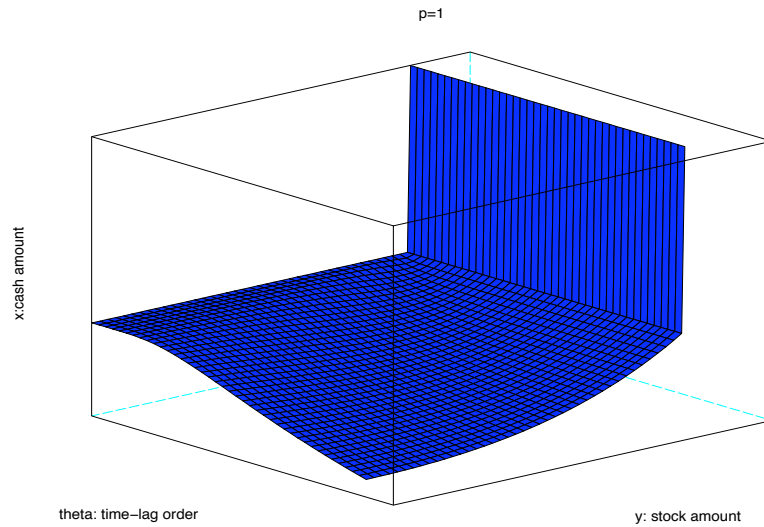

Figure 3: Lower bound of the domain  $\mathcal{S}$  for fixed  $p$  with  $f(e, \theta) = \bar{\kappa}_b \exp(\frac{e}{\theta})$  for  $e < 0$  and  $\bar{\kappa}_b = 0.9$ . Notice that when  $\theta$  is fixed, we obtain the Figure 1.

where  $\mathcal{A}_\ell(t, z, \theta) = \{\alpha \in \mathcal{A}(t, z, \theta) : Y_T = 0\}$ . Notice that this set is nonempty. Indeed, let  $(t, z, \theta) \in [0, T] \times \bar{\mathcal{S}}$ , and consider the impulse control strategy  $\tilde{\alpha} = (\tau_n, \zeta_n)_{n \geq 0}$ ,  $\tau_0 = t - \theta$ , consisting in liquidating immediately all the stock shares, and then doing no transaction anymore, i.e.  $(\tau_1, \zeta_1) = (t, -y)$ , and  $\zeta_n = 0$ ,  $n \geq 2$ . The associated state process  $(Z = (X, Y, P), \Theta)$  satisfies  $X_s = L(z, \theta)$ ,  $Y_s = 0$ , which shows that  $L(Z_s, \Theta_s) = X_s = L(z, \theta) \geq 0$ ,  $t \leq s \leq T$ , and thus  $\tilde{\alpha} \in \mathcal{A}_\ell(t, z, \theta) \neq \emptyset$ . Observe also that for  $\alpha \in \mathcal{A}_\ell(t, z, \theta)$ ,  $X_T = L(Z_T, \Theta_T) \geq 0$ , so that the expectations in (2.9), and the value function  $v$  are well-defined in  $[0, \infty]$ . Moreover, by considering the particular strategy  $\tilde{\alpha}$  described above, which leads to a final liquidation value  $X_T = L(z, \theta)$ , we obtain a lower-bound for the value function:

$$v(t, z, \theta) \geq U(L(z, \theta)), \quad (t, z, \theta) \in [0, T] \times \bar{\mathcal{S}}. \quad (2.10)$$

**Remark 2.2** We can shift the terminal liquidation constraint in  $\mathcal{A}_\ell(t, z, \theta)$  to a terminal liquidation utility by considering the function  $U_L$  defined on  $\bar{\mathcal{S}}$  by:

$$U_L(z, \theta) = U(L(z, \theta)), \quad (z, \theta) \in \bar{\mathcal{S}}.$$

Then, problem (2.9) is written equivalently in

$$\bar{v}(t, z, \theta) = \sup_{\alpha \in \mathcal{A}(t, z, \theta)} \mathbb{E} \left[ U_L(Z_T, \Theta_T) \right], \quad (t, z, \theta) \in [0, T] \times \bar{\mathcal{S}}. \quad (2.11)$$

Indeed, by observing that for all  $\alpha \in \mathcal{A}_\ell(t, z, \theta)$ , we have  $\mathbb{E}[U(X_T)] = \mathbb{E}[U_L(Z_T, \Theta_T)]$ , and since  $\mathcal{A}_\ell(t, z, \theta) \subset \mathcal{A}(t, z, \theta)$ , it is clear that  $v \leq \bar{v}$ . Conversely, for any  $\alpha \in \mathcal{A}(t, z, \theta)$  associated to the state controlled process  $(Z, \Theta)$ , consider the impulse control strategy  $\tilde{\alpha} = \alpha \cup (T, -Y_T)$  consisting in liquidating all the stock shares  $Y_T$  at time  $T$ . The corresponding state process  $(\tilde{Z}, \tilde{\Theta})$  satisfies clearly:  $(\tilde{Z}_s, \tilde{\Theta}_s) = (Z_s, \Theta_s)$  for  $t \leq s < T$ , and  $\tilde{X}_T = L(Z_T, \Theta_T)$ ,  $\tilde{Y}_T = 0$ , and so  $\tilde{\alpha} \in \mathcal{A}_\ell(t, z, \theta)$ . We deduce that  $\mathbb{E}[U_L(Z_T, \Theta_T)] = \mathbb{E}[U(\tilde{X}_T)] \leq v(t, z, \theta)$ , and so since  $\alpha$  is arbitrary in  $\mathcal{A}(t, z, \theta)$ ,  $\bar{v}(t, z, \theta) \leq v(t, z, \theta)$ . This proves the equality  $v = \bar{v}$ . Actually, the above arguments also show that  $\sup_{\alpha \in \mathcal{A}_\ell(t, z, \theta)} U(X_T) = \sup_{\alpha \in \mathcal{A}(t, z, \theta)} U_L(Z_T, \Theta_T)$ .

**Remark 2.3** Following Remark 2.1, we can formulate a continuous-time trading version of our illiquid market model with stock price  $P$  and temporary price impact  $\bar{f}$ . The trading strategy is given by a  $\mathbb{F}$ -adapted process  $\eta = (\eta_t)_{0 \leq t \leq T}$  representing the instantaneous trading rate, which means that the dynamics of the cumulative number of stock shares  $Y$  is governed by:  $dY_t = \eta_t dt$ . The cash holdings  $X$  follows

$$dX_t = -\eta_t P_t \bar{f}(\eta_t) dt.$$

Notice that in a continuous-time trading formulation, the time interval between trades is  $\Theta_t = 0$  at any time  $t$ . Under condition **(H3)**, the liquidation value is then given at any time  $t$  by:

$$L(X_t, Y_t, P_t, 0) = X_t, \quad 0 \leq t \leq T,$$

and does not take into account the position in stock shares, which is economically undesirable. On the contrary, by explicitly considering the time interval between trades in our discrete-time trading formulation, we take into account the position in stock.

### 3 Properties of the model

In this section, we show that the illiquid market model presented in the previous section displays some interesting and economically meaningful properties on the admissible trading strategies and the optimal performance, i.e. the value function. Let us consider the impulse transaction function  $\Gamma$  defined on  $\mathbb{R} \times \mathbb{R}_+ \times \mathbb{R}_+^* \times [0, T] \times \mathbb{R}$  into  $\mathbb{R} \cup \{-\infty\} \times \mathbb{R} \times \mathbb{R}_+^*$  by:

$$\Gamma(z, \theta, e) = \left( x - epf(e, \theta), y + e, p \right),$$

for  $z = (x, y, p)$ , and set  $\bar{\Gamma}(z, \theta, e) = (\Gamma(z, \theta, e), 0)$ . This corresponds to the value of the state variable  $(Z, \Theta)$  immediately after a trading at time  $t = \tau_{n+1}$  of  $\zeta_{n+1}$  shares of stock, i.e.  $(Z_{\tau_{n+1}}, \Theta_{\tau_{n+1}}) = (\Gamma(Z_{\tau_{n+1}}^-, \Theta_{\tau_{n+1}}^-, \zeta_{n+1}), 0)$ . We then define the set of admissible transactions:

$$\mathcal{C}(z, \theta) = \left\{ e \in \mathbb{R} : (\Gamma(z, \theta, e), 0) \in \bar{\mathcal{S}} \right\}, \quad (z, \theta) \in \bar{\mathcal{S}}.$$

This means that for any  $\alpha = (\tau_n, \zeta_n)_{n \geq 0} \in \mathcal{A}(t, z, \theta)$  with associated state process  $(Z, \Theta)$ , we have  $\zeta_n \in \mathcal{C}(Z_{\tau_n}^-, \Theta_{\tau_n}^-)$ ,  $n \geq 1$ . We define the impulse operator  $\mathcal{H}$  by

$$\mathcal{H}\varphi(t, z, \theta) = \sup_{e \in \mathcal{C}(z, \theta)} \varphi(t, \Gamma(z, \theta, e), 0), \quad (t, z, \theta) \in [0, T] \times \bar{\mathcal{S}}.$$

We also introduce the liquidation function corresponding to the classical Merton model without market impact:

$$L_M(z) = x + py, \quad \forall z = (x, y, p) \in \mathbb{R} \times \mathbb{R} \times \mathbb{R}_+^*.$$

For  $(t, z, \theta) \in [0, T] \times \bar{\mathcal{S}}$ , with  $z = (x, y, p)$ , we denote by  $(Z^{0,t,z}, \Theta^{0,t,\theta})$  the state process starting from  $(z, \theta)$  at time  $t$ , and without any impulse control strategy: it is given by

$$\left( Z_s^{0,t,z}, \Theta_s^{0,t,\theta} \right) = \left( x, y, P_s^{t,p}, \theta + s - t \right), \quad t \leq s \leq T,$$

where  $P^{t,p}$  is the solution to (2.3) starting from  $p$  at time  $t$ . Notice that  $(Z^{0,t,z}, \Theta^{0,t,\theta})$  is the continuous part of the state process  $(Z, \Theta)$  controlled by  $\alpha \in \mathcal{A}(t, z, \theta)$ . The infinitesimal generator  $\mathcal{L}$  associated to the process  $(Z^{0,t,z}, \Theta^{0,t,\theta})$  is

$$\mathcal{L}\varphi + \frac{\partial \varphi}{\partial \theta} = bp \frac{\partial \varphi}{\partial p} + \frac{1}{2} \sigma^2 p^2 \frac{\partial^2 \varphi}{\partial p^2} + \frac{\partial \varphi}{\partial \theta}.$$

We first prove a useful result on the set of admissible transactions.

**Lemma 3.1** *Assume that (H1), (H2) and (H3) hold. Then, for all  $(z, \theta) \in \bar{\mathcal{S}}$ , with  $z = (x, y, p)$ , the set  $\mathcal{C}(z, \theta)$  is compact in  $\mathbb{R}$  and satisfy*

$$\mathcal{C}(z, \theta) \subset [-y, \bar{e}(z, \theta)], \tag{3.1}$$

where  $-y \leq \bar{e}(z, \theta) < \infty$  is given by

$$\bar{e}(z, \theta) = \begin{cases} \sup \left\{ e \in \mathbb{R} : epf(e, \theta) \leq x \right\}, & \text{if } \theta > 0 \\ 0, & \text{if } \theta = 0. \end{cases}$$

For  $\theta = 0$ , (3.1) becomes an equality :  $\mathcal{C}(z, 0) = [-y, 0]$ .

The set function  $\mathcal{C}$  is continuous with respect to the Hausdorff metric, i.e. if  $(z_n, \theta_n)$  converges to  $(z, \theta)$  in  $\bar{\mathcal{S}}$ , and  $(e_n)$  is a sequence in  $\mathcal{C}(z_n, \theta_n)$  converging to  $e$ , then  $e \in \mathcal{C}(z, \theta)$ . Moreover, if  $e \in \mathbb{R} \mapsto ef(e, \theta)$  is strictly increasing for  $\theta \in (0, T]$ , then for  $(z, \theta) \in \partial_L \mathcal{S}$  with  $\theta > 0$ , we have  $\bar{e}(z, \theta) = -y$ , i.e.  $\mathcal{C}(z, \theta) = \{-y\}$ .

**Proof.** By definition of the impulse transaction function  $\Gamma$  and the liquidation function  $L$ , we immediately see that the set of admissible transactions is written as

$$\begin{aligned} \mathcal{C}(z, \theta) &= \left\{ e \in \mathbb{R} : x - epf(e, \theta) \geq 0, \text{ and } y + e \geq 0 \right\} \\ &= \left\{ e \in \mathbb{R} : epf(e, \theta) \leq x \right\} \cap [-y, \infty) =: \mathcal{C}_1(z, \theta) \cap [-y, \infty). \end{aligned} \quad (3.2)$$

It is clear that  $\mathcal{C}(z, \theta)$  is closed and bounded, thus a compact set. Under **(H1)** and **(H2)**, we have  $\lim_{e \rightarrow \infty} epf(e, \theta) = \infty$ . Hence we get  $\bar{e}(z, \theta) < \infty$  and  $\mathcal{C}_1(z, \theta) \subset (-\infty, \bar{e}(z, \theta)]$ . From (3.2), we get (3.1). Suppose  $\theta = 0$ . Under **(H3)**, using  $(z, \theta) \in \bar{\mathcal{S}}$ , we have  $\mathcal{C}_1(z, \theta) = \mathbb{R}_-$ . From (3.2), we get  $\mathcal{C}(z, \theta) = [-y, 0]$ .

Let us now prove the continuity of the set of admissible transactions. Consider a sequence  $(z_n, \theta_n)$  in  $\bar{\mathcal{S}}$ , with  $z_n = (x_n, y_n, p_n)$ , converging to  $(z, \theta) \in \bar{\mathcal{S}}$ , and a sequence  $(e_n)$  in  $\mathcal{C}(z_n, \theta_n)$  converging to  $e$ . Suppose first that  $\theta > 0$ . Then, for  $n$  large enough,  $\theta_n > 0$  and by observing that  $(z, \theta, e) \mapsto \bar{\Gamma}(z, \theta, e)$  is continuous on  $\mathbb{R} \times \mathbb{R}_+ \times \mathbb{R}_+^* \times \mathbb{R}_+^* \times \mathbb{R}$ , we immediately deduce that  $e \in \mathcal{C}(z, \theta)$ . In the case  $\theta = 0$ , writing  $x_n - e_n f(e_n, \theta_n) \geq 0$ , using **(H3)**(ii) and sending  $n$  to infinity, we see that  $e$  should necessarily be nonpositive. By writing also that  $y_n + e_n \geq 0$ , we get by sending  $n$  to infinity that  $y + e \geq 0$ , and therefore  $e \in \mathcal{C}(z, 0) = [-y, 0]$ .

Suppose finally that  $e \in \mathbb{R} \mapsto ef(e, \theta)$  is increasing, and fix  $(z, \theta) \in \partial_L \mathcal{S}$ , with  $\theta > 0$ . Then,  $L(z, \theta) = 0$ , i.e.  $x = -ypf(-y, \theta)$ . Set  $\bar{e} = \bar{e}(z, \theta)$ . By writing that  $\bar{e}pf(\bar{e}, \theta) \leq x = -ypf(-y, \theta)$ , and  $\bar{e} \geq -y$ , we deduce from the increasing monotonicity of  $e \mapsto epf(e, \theta)$  that  $\bar{e} = -y$ .  $\square$

**Remark 3.1** The previous Lemma implies in particular that  $\mathcal{C}(z, 0) \subset \mathbb{R}_-$ , which means that an admissible transaction after an immediate trading should be necessarily a sale. In other words, given  $\alpha = (\tau_n, \zeta_n)_{n \geq 0} \in \mathcal{A}(t, z, \theta)$ ,  $(t, z, \theta) \in [0, T] \times \bar{\mathcal{S}}$ , if  $\Theta_{\tau_n^-} = 0$ , then  $\zeta_n \leq 0$ . The continuity property of  $\mathcal{C}$  ensures that the operator  $\mathcal{H}$  preserves the lower and upper-semicontinuity (see (A.3) in Appendix). This Lemma also asserts that, under the assumption of increasing monotonicity of  $e \mapsto ef(e, \theta)$ , when the state is in the boundary  $L = 0$ , then the only admissible transaction is to liquidate all stock shares. This increasing monotonicity means that the amount traded is increasing with the size of the order. Such an assumption is satisfied in the example (2.6) of temporary price impact function  $f$  for  $\beta = 2$ , but is not fulfilled for  $\beta = 1$ . In this case, the presence of illiquidity cost implies that it may be more advantageous to split the order size.

We next state some useful bounds on the liquidation value associated to an admissible transaction.

**Lemma 3.2** *Assume that (H1) holds. Then, we have for all  $(t, z, \theta) \in [0, T] \times \bar{\mathcal{S}}$ :*

$$0 \leq L(z, \theta) \leq L_M(z), \quad (3.3)$$

$$L_M(\Gamma(z, \theta, e)) \leq L_M(z), \quad \forall e \in \mathbb{R}, \quad (3.4)$$

$$\sup_{\alpha \in \mathcal{A}(t, z, \theta)} L(Z_s, \Theta_s) \leq L_M(Z_s^{0, t, z}), \quad t \leq s \leq T. \quad (3.5)$$

Furthermore, under (H2), we have for all  $(z, \theta) \in \bar{\mathcal{S}}$ ,  $z = (x, y, p)$ ,

$$L_M(\Gamma(z, \theta, e)) \leq L_M(z) - \min(\underline{\kappa}_a - 1, 1 - \bar{\kappa}_b) |e| p, \quad \forall e \in \mathbb{R}. \quad (3.6)$$

**Proof.** Under (H1), we have  $f(e, \theta) \leq 1$  for all  $e \leq 0$ , which shows clearly (3.3). From the definition of  $L_M$  and  $\Gamma$ , we see that for all  $e \in \mathbb{R}$ ,

$$L_M(\Gamma(z, \theta, e)) - L_M(z) = ep(1 - f(e, \theta)), \quad (3.7)$$

which yields the inequality (3.4). Fix some arbitrary  $\alpha = (\tau_n, \zeta_n)_{n \geq 0} \in \mathcal{A}(t, z, \theta)$  associated to the controlled state process  $(Z, \Theta)$ . When a transaction occurs at time  $s = \tau_n$ ,  $n \geq 1$ , the jump of  $L_M(Z)$  is nonpositive by (3.4):

$$\Delta L_M(Z_s) = L_M(Z_{\tau_n}) - L_M(Z_{\tau_n}^-) = L_M(\Gamma(Z_{\tau_n}^-, \Theta_{\tau_n}^-, \zeta_n)) - L_M(Z_{\tau_n}^-) \leq 0.$$

We deduce that the process  $L_M(Z)$  is smaller than its continuous part equal to  $L_M(Z^{0, t, z})$ , and we then get (3.5) with (3.3). Finally, under the additional condition (H2), we easily obtain inequality (3.6) from relation (3.7).  $\square$

We now check that our liquidation problem is well-posed by stating a natural upper-bound on the optimal performance, namely that the value function in our illiquid market model is bounded by the usual Merton bound in a perfectly liquid market.

**Proposition 3.1** *Assume that (H1) and (H5) hold. Then, for all  $(t, z, \theta) \in [0, T] \times \bar{\mathcal{S}}$ , the family  $\{U_L(Z_T, \Theta_T), \alpha \in \mathcal{A}(t, z, \theta)\}$  is uniformly integrable, and we have*

$$\begin{aligned} v(t, z, \theta) \leq v_0(t, z) &:= \mathbb{E} \left[ U \left( L_M(Z_T^{0, t, z}) \right) \right], \quad (t, z, \theta) \in [0, T] \times \bar{\mathcal{S}}, \\ &\leq K e^{\rho(T-t)} L_M(z)^\gamma, \end{aligned} \quad (3.8)$$

where  $\rho$  is a positive constant s.t.

$$\rho \geq \frac{\gamma}{1 - \gamma} \frac{b^2}{2\sigma^2}. \quad (3.9)$$

**Proof.** From (3.5) and the nondecreasing monotonicity of  $U$ , we have for all  $(t, z, \theta) \in [0, T] \times \bar{\mathcal{S}}$ :

$$\sup_{\alpha \in \mathcal{A}_\ell(t, z, \theta)} U(X_T) = \sup_{\alpha \in \mathcal{A}(t, z, \theta)} U_L(Z_T, \Theta_T) \leq U(L_M(Z_T^{0, t, z})),$$

and all the assertions of the Proposition will follow once we prove the inequality (3.8). For this, consider the nonnegative function  $\varphi$  defined on  $[0, T] \times \bar{\mathcal{S}}$  by:

$$\varphi(t, z, \theta) = e^{\rho(T-t)} L_M(z)^\gamma = e^{\rho(T-t)} (x + py)^\gamma,$$

and notice that  $\varphi$  is smooth  $C^2$  on  $[0, T] \times (\bar{\mathcal{S}} \setminus D_0)$ . We claim that for  $\rho > 0$  large enough, the function  $\varphi$  satisfies:

$$-\frac{\partial \varphi}{\partial t} - \frac{\partial \varphi}{\partial \theta} - \mathcal{L}\varphi \geq 0, \quad \text{on } [0, T] \times (\bar{\mathcal{S}} \setminus D_0).$$

Indeed, a straightforward calculation shows that for all  $(t, z, \theta) \in [0, T] \times (\bar{\mathcal{S}} \setminus D_0)$ :

$$\begin{aligned} & -\frac{\partial \varphi}{\partial t}(t, z, \theta) - \frac{\partial \varphi}{\partial \theta}(t, z, \theta) - \mathcal{L}\varphi(t, z, \theta) \\ &= e^{\rho(T-t)} L_M(z)^{\gamma-2} \left[ \left( \sqrt{\rho} L_M(z) + \frac{b\gamma}{2\sqrt{\rho}} yp \right)^2 + \left( \frac{\gamma(1-\gamma)\sigma^2}{2} - \frac{b^2\gamma^2}{4\rho} \right) y^2 p^2 \right] \end{aligned} \quad (3.10)$$

which is nonnegative under condition (3.9).

Fix some  $(t, z, \theta) \in [0, T] \times \bar{\mathcal{S}}$ . If  $(z, \theta) = (0, 0, p, \theta) \in D_0$ , then we clearly have  $v_0(t, z, \theta) = U(0)$ , and inequality (3.8) is trivial. Otherwise, if  $(z, \theta) \in \bar{\mathcal{S}} \setminus D_0$ , then the process  $(Z^{0,t,z}, \Theta^{0,t,\theta})$  satisfy  $L_M(Z^{0,t,z}, \Theta^{0,t,\theta}) > 0$ . Indeed, denote by  $(\bar{Z}^{t,z}, \bar{\Theta}^{t,\theta})$  the process starting from  $(z, \theta)$  at  $t$  and associated to the strategy consisting in liquidating all stock shares at  $t$ . Then we have  $(\bar{Z}_s^{t,z}, \bar{\Theta}_s^{t,\theta}) \in \bar{\mathcal{S}} \setminus D_0$  for all  $s \in [t, T]$  and hence  $L_M(\bar{Z}_s^{t,z}, \bar{\Theta}_s^{t,\theta}) > 0$  for all  $s \in [t, T]$ . Using (3.5) we get  $L_M(Z_s^{0,t,z}, \Theta_s^{0,t,\theta}) \geq L_M(\bar{Z}_s^{t,z}, \bar{\Theta}_s^{t,\theta}) > 0$ .

We can then apply Itô's formula to  $\varphi(s, Z_s^{0,t,z}, \Theta_s^{0,t,\theta})$  between  $t$  and  $T_R = \inf\{s \geq t : |Z_s^{0,t,z}| \geq R\} \wedge T$ :

$$\begin{aligned} \mathbb{E}[\varphi(T_R, Z_{T_R}^{0,t,z}, \Theta_{T_R}^{0,t,\theta})] &= \varphi(t, z) + \mathbb{E} \left[ \int_t^{T_R} \left( \frac{\partial \varphi}{\partial t} + \frac{\partial \varphi}{\partial \theta} + \mathcal{L}\varphi \right) (s, Z_s^{0,t,z}, \Theta_s^{0,t,\theta}) ds \right] \\ &\leq \varphi(t, z). \end{aligned}$$

(The stochastic integral term vanishes in expectation since the integrand is bounded before  $T_R$ ). By sending  $R$  to infinity, we get by Fatou's lemma and since  $\varphi(T, z, \theta) = L_M(z)^\gamma$ :

$$\mathbb{E} \left[ L_M(Z_T^{0,t,z})^\gamma \right] \leq \varphi(t, z, \theta).$$

We conclude with the growth condition **(H5)**. □

As a direct consequence of the previous Proposition, we obtain the continuity of the value function on the boundary  $\partial_y \mathcal{S}$ , i.e. when we start with no stock shares.

**Corollary 3.1** *Assume that **(H1)** and **(H5)** hold. Then, the value function  $v$  is continuous on  $[0, T] \times \partial_y \mathcal{S}$ , and we have*

$$v(t, z, \theta) = U(x), \quad \forall t \in [0, T], (z, \theta) = (x, 0, p, \theta) \in \partial_y \mathcal{S}.$$

*In particular, we have  $v(t, z, \theta) = U(0) = 0$ , for all  $(t, z, \theta) \in [0, T] \times D_0$ .*

**Proof.** From the lower-bound (2.10) and the upper-bound in Proposition 3.1, we have for all  $(t, z, \theta) \in [0, T] \times \bar{\mathcal{S}}$ ,

$$U \left( x + ypf(-y, \theta) \right) \leq v(t, z, \theta) \leq \mathbb{E} [ U(L_M(Z_T^{0,t,z})) ] = \mathbb{E} [ U(x + yP_T^{t,p}) ].$$

These two inequalities imply the required result. □

The following result states the finiteness of the total number of shares and amount traded.

**Proposition 3.2** *Assume that (H1) and (H2) hold. Then, for any  $\alpha = (\tau_n, \zeta_n)_{n \geq 0} \in \mathcal{A}(t, z, \theta)$ ,  $(t, z, \theta) \in [0, T] \times \bar{\mathcal{S}}$ , we have*

$$\sum_{n \geq 1} |\zeta_n| < \infty, \quad \sum_{n \geq 1} |\zeta_n| P_{\tau_n} < \infty, \quad \text{and} \quad \sum_{n \geq 1} |\zeta_n| P_{\tau_n} f(\zeta_n, \Theta_{\tau_n}^-) < \infty, \quad a.s.$$

**Proof.** Fix  $(t, z, \theta) \in [0, T] \times \bar{\mathcal{S}}$ , and  $\alpha = (\tau_n, \zeta_n)_{n \geq 0} \in \mathcal{A}(t, z, \theta)$ . Observe first that the continuous part of the process  $L_M(Z)$  is  $L_M(Z^{0,t,z})$ , and we denote its jump at time  $\tau_n$  by  $\Delta L_M(Z_{\tau_n}) = L_M(Z_{\tau_n}) - L_M(Z_{\tau_n}^-)$ . From the estimates (3.3) and (3.6) in Lemma 3.2, we then have almost surely for all  $n \geq 1$ ,

$$\begin{aligned} 0 \leq L_M(Z_{\tau_n}) &= L_M(Z_{\tau_n}^{0,t,z}) + \sum_{k=1}^n \Delta L_M(Z_{\tau_k}) \\ &\leq L_M(Z_{\tau_n}^{0,t,z}) - \bar{\kappa} \sum_{k=1}^n |\zeta_k| P_{\tau_k}, \end{aligned}$$

where we set  $\hat{\kappa} = \min(\underline{\kappa}_a - 1, 1 - \bar{\kappa}_b) > 0$ . We deduce that for all  $n \geq 1$ ,

$$\sum_{k=1}^n |\zeta_k| P_{\tau_k} \leq \frac{1}{\hat{\kappa}} \sup_{s \in [t, T]} L_M(Z_s^{0,t,z}) = \frac{1}{\hat{\kappa}} (x + y \sup_{s \in [t, T]} P_s^{t,p}) < \infty, \quad a.s.$$

This shows the almost sure convergence of the series  $\sum_n |\zeta_n| P_{\tau_n}$ . Moreover, since the price process  $P$  is continuous and strictly positive, we also obtain the convergence of the series  $\sum_n |\zeta_n|$ . Recalling that  $f(e, \theta) \leq 1$  for all  $e \leq 0$  and  $\theta \in [0, T]$ , we have for all  $n \geq 1$ .

$$\begin{aligned} \sum_{k=1}^n |\zeta_k| P_{\tau_k} f(\zeta_k, \Theta_{\tau_k}^-) &= \sum_{k=1}^n \zeta_k P_{\tau_k} f(\zeta_k, \Theta_{\tau_k}^-) + 2 \sum_{k=1}^n |\zeta_k| P_{\tau_k} f(\zeta_k, \Theta_{\tau_k}^-) \mathbf{1}_{\zeta_k \leq 0} \\ &\leq \sum_{k=1}^n \zeta_k P_{\tau_k} f(\zeta_k, \Theta_{\tau_k}^-) + 2 \sum_{k=1}^n |\zeta_k| P_{\tau_k}. \end{aligned} \quad (3.11)$$

On the other hand, we have

$$\begin{aligned} 0 \leq L_M(Z_{\tau_n}) &= X_{\tau_n} + Y_{\tau_n} P_{\tau_n} \\ &= x - \sum_{k=1}^n \zeta_k P_{\tau_k} f(\zeta_k, \Theta_{\tau_k}^-) + (y + \sum_{k=1}^n \zeta_k) P_{\tau_n}. \end{aligned}$$

Together with (3.11), this implies that for all  $n \geq 1$ ,

$$\sum_{k=1}^n |\zeta_k| P_{\tau_k} f(\zeta_k, \Theta_{\tau_k}^-) \leq x + (y + \sum_{k=1}^n |\zeta_k|) \sup_{s \in [t, T]} P_s^{t,p} + 2 \sum_{k=1}^n |\zeta_k| P_{\tau_k}.$$

The convergence of the series  $\sum_n |\zeta_n| P_{\tau_n} f(\zeta_n, \Theta_{\tau_n}^-)$  follows therefore from the convergence of the series  $\sum_n |\zeta_n|$  and  $\sum_n |\zeta_n| P_{\tau_n}$ .  $\square$

As a consequence of the above results, we can now prove that in the optimal portfolio liquidation, it suffices to restrict to a finite number of trading times, which are strictly



increasing. Given a trading strategy  $\alpha = (\tau_n, \zeta_n)_{n \geq 0} \in \mathcal{A}$ , let us denote by  $N(\alpha)$  the process counting the number of intervention times:

$$N_t(\alpha) = \sum_{n \geq 1} \mathbf{1}_{\tau_n \leq t}, \quad 0 \leq t \leq T.$$

We denote by  $\mathcal{A}_\ell^b(t, z, \theta)$  the set of admissible trading strategies in  $\mathcal{A}_\ell(t, z, \theta)$  with a finite number of trading times, such that these trading times are strictly increasing, namely:

$$\begin{aligned} \mathcal{A}_\ell^b(t, z, \theta) = & \left\{ \alpha = (\tau_n, \zeta_n)_{n \geq 0} \in \mathcal{A}_\ell(t, z, \theta) : N_T(\alpha) < \infty, \quad a.s. \right. \\ & \left. \text{and } \tau_n < \tau_{n+1} \quad a.s., \quad 0 \leq n \leq N_T(\alpha) - 1 \right\}. \end{aligned}$$

For any  $\alpha = (\tau_n, \zeta_n)_n \in \mathcal{A}_\ell^b(t, z, \theta)$ , the associated state process  $(Z, \Theta)$  satisfies  $\Theta_{\tau_{n+1}^-} > 0$ , i.e.  $(Z_{\tau_{n+1}^-}, \Theta_{\tau_{n+1}^-}) \in \bar{\mathcal{S}}^* := \{(z, \theta) \in \bar{\mathcal{S}} : \theta > 0\}$ . We also set  $\partial_L \mathcal{S}^* = \partial_L \mathcal{S} \cap \bar{\mathcal{S}}^*$ .

**Theorem 3.1** *Assume that (H1), (H2), (H3), (H4) and (H5) hold. Then, we have*

$$v(t, z, \theta) = \sup_{\alpha \in \mathcal{A}_\ell^b(t, z, \theta)} \mathbb{E}[U(X_T)], \quad (t, z, \theta) \in [0, T] \times \bar{\mathcal{S}}. \quad (3.12)$$

Moreover, we have

$$v(t, z, \theta) = \sup_{\alpha \in \mathcal{A}_{\ell+}^b(t, z, \theta)} \mathbb{E}[U(X_T)], \quad (t, z, \theta) \in [0, T] \times (\bar{\mathcal{S}} \setminus \partial_L \mathcal{S}), \quad (3.13)$$

where  $\mathcal{A}_{\ell+}^b(t, z, \theta) = \{\alpha \in \mathcal{A}_\ell^b(t, z, \theta) : (Z_s, \Theta_s) \in (\bar{\mathcal{S}} \setminus \partial_L \mathcal{S}), t \leq s < T\}$ .

**Proof. Step 1.** Fix  $(t, z, \theta) \in [0, T] \times \bar{\mathcal{S}}$ , and denote by  $\bar{\mathcal{A}}_\ell^b(t, z, \theta)$  the set of admissible trading strategies in  $\mathcal{A}_\ell(t, z, \theta)$  with a finite number of trading times:

$$\bar{\mathcal{A}}_\ell^b(t, z, \theta) = \left\{ \alpha = (\tau_k, \zeta_k)_{k \geq 0} \in \mathcal{A}_\ell(t, z, \theta) : N_T(\alpha) \text{ is bounded a.s.} \right\}.$$

Given an arbitrary  $\alpha = (\tau_k, \zeta_k)_{k \geq 0} \in \mathcal{A}_\ell(t, z, \theta)$  associated to the state process  $(Z, \Theta) = (X, Y, P, \Theta)$ , let us consider the truncated trading strategy  $\alpha^{(n)} = (\tau_k, \zeta_k)_{k \leq n} \cup (\tau_{n+1}, -Y_{\tau_{n+1}^-})$ , which consists in liquidating all stock shares at time  $\tau_{n+1}$ . This strategy  $\alpha^{(n)}$  lies in  $\bar{\mathcal{A}}_\ell(t, z, \theta)$ , and is associated to the state process denoted by  $(Z^{(n)}, \Theta^{(n)})$ . We then have

$$X_T^{(n)} - X_T = \sum_{k \geq n+1} \zeta_k P_{\tau_k} f(\zeta_k, \Theta_{\tau_k^-}) + Y_{\tau_{n+1}^-} P_{\tau_{n+1}} f(-Y_{\tau_{n+1}^-}, \Theta_{\tau_{n+1}^-}).$$

Now, from Proposition 3.2, we have

$$\sum_{k \geq n+1} \zeta_k P_{\tau_k} f(\zeta_k, \Theta_{\tau_k^-}) \longrightarrow 0 \quad a.s. \quad \text{when } n \rightarrow \infty.$$

Moreover, since  $0 \leq Y_{\tau_{n+1}^-} = Y_{\tau_n}$  goes to  $Y_T = 0$  as  $n$  goes to infinity, by definition of  $\alpha \in \mathcal{A}_\ell(t, z, \theta)$ , and recalling that  $f$  is smaller than 1 on  $\mathbb{R}_- \times [0, T]$ , we deduce that

$$\begin{aligned} 0 \leq Y_{\tau_{n+1}^-} P_{\tau_{n+1}} f(-Y_{\tau_{n+1}^-}, \Theta_{\tau_{n+1}^-}) & \leq Y_{\tau_{n+1}^-} \sup_{s \in [t, T]} P_s^{t, p} \\ & \longrightarrow 0 \quad a.s. \quad \text{when } n \rightarrow \infty. \end{aligned}$$

This proves that  $X_T^{(n)} \rightarrow X_T$  a.s. when  $n$  goes to infinity. From Proposition 3.1, the sequence  $(U(X_T^{(n)}))_{n \geq 1}$  is uniformly integrable, and we can apply the dominated convergence theorem to get:  $\mathbb{E}[U(X_T^{(n)})] \rightarrow \mathbb{E}[U(X_T)]$ , when  $n$  goes to infinity. Since  $\alpha$  is arbitrary in  $\mathcal{A}_\ell(t, z, \theta)$ , this shows that

$$v(t, z, \theta) \leq \bar{v}^b(t, z, \theta) := \sup_{\alpha \in \bar{\mathcal{A}}_\ell^b(t, z, \theta)} \mathbb{E}[U(X_T)],$$

and actually the equality  $v = \bar{v}^b$  since the other inequality  $\bar{v}^b \leq v$  is trivial from the inclusion  $\bar{\mathcal{A}}_\ell^b(t, z, \theta) \subset \mathcal{A}_\ell(t, z, \theta)$ .

**Step 2.** Denote by  $v^b$  the value function in the r.h.s. of (3.12). It is clear that  $v^b \leq \bar{v}^b = v$  since  $\mathcal{A}_\ell^b(t, z, \theta) \subset \bar{\mathcal{A}}_\ell^b(t, z, \theta)$ . To prove the reverse inequality we need first to study the behavior of optimal strategies at time  $T$ . Introduce the set

$$\tilde{\mathcal{A}}_\ell^b(t, z, \theta) = \left\{ \alpha = (\tau_k, \zeta_k)_k \in \mathcal{A}_\ell^b(t, z, \theta) : \#\{k : \tau_k = T\} \leq 1 \right\},$$

and denote by  $\tilde{v}^b$  the associated value function. Then we have  $\tilde{v}^b \leq \bar{v}^b$ . Indeed, let  $\alpha = (\tau_k, \zeta_k)_k$  be some arbitrary element in  $\tilde{\mathcal{A}}_\ell^b(t, z, \theta)$ ,  $(t, z = (x, y, p), \theta) \in [0, T] \times \bar{\mathcal{S}}$ . If  $\alpha \in \tilde{\mathcal{A}}_\ell^b(t, z, \theta)$  then we have  $\tilde{v}^b(t, z, \theta) \geq \mathbb{E}[U_L(Z_T, \Theta_T)]$ , where  $(Z, \Theta)$  denotes the process associated to  $\alpha$ . Suppose now that  $\alpha \notin \tilde{\mathcal{A}}_\ell^b(t, z, \theta)$ . Set  $m = \max\{k : \tau_k < T\}$ . Then define the stopping time  $\tau' := \frac{\tau_m + T}{2}$  and the  $\mathcal{F}_{\tau'}$ -measurable random variable  $\zeta' := \operatorname{argmax}\{ef(e, T - \tau_m) : e \geq -Y_{\tau_m}\}$ . Define the strategy  $\alpha' = (\tau_k, \zeta_k)_{k \leq m} \cup (\tau', Y_{\tau_m} - \zeta') \cup (T, \zeta')$ . From the construction of  $\alpha'$ , we easily check that  $\alpha' \in \tilde{\mathcal{A}}_\ell^b(t, z, \theta)$  and  $\mathbb{E}[U_L(Z_T, \Theta_T)] \leq \mathbb{E}[U_L(Z'_T, \Theta'_T)]$  where  $(Z', \Theta')$  denotes the process associated to  $\alpha'$ . Thus,  $\tilde{v}^b \geq \bar{v}^b$ .

We now prove that  $v^b \geq \tilde{v}^b$ . Let  $\alpha = (\tau_k, \zeta_k)_k$  be some arbitrary element in  $\tilde{\mathcal{A}}_\ell^b(t, z, \theta)$ ,  $(t, z = (x, y, p), \theta) \in [0, T] \times \bar{\mathcal{S}}$ . Denote by  $N = N_T(\alpha)$  the a.s. finite number of trading times in  $\alpha$ . We set  $m = \inf\{0 \leq k \leq N - 1 : \tau_{k+1} = \tau_k\}$  and  $M = \sup\{m + 1 \leq k \leq N : \tau_k = \tau_m\}$  with the convention that  $\inf \emptyset = \sup \emptyset = N + 1$ . We then define  $\alpha' = (\tau'_k, \zeta'_k)_{0 \leq k \leq N - (M - m) + 1} \in \mathcal{A}$  by:

$$(\tau'_k, \zeta'_k) = \begin{cases} (\tau_k, \zeta_k), & \text{for } 0 \leq k < m \\ (\tau_m = \tau_M, \sum_{k=m}^M \zeta_k), & \text{for } k = m \text{ and } m < N, \\ (\tau_{k+M-m}, \zeta_{k+M-m}), & \text{for } m + 1 \leq k \leq N - (M - m) \text{ and } m < N, \\ (\tau', \sum_{l=m+1}^M \zeta_l) & \text{for } k = N - (M - m) + 1 \end{cases}$$

where  $\tau' = \frac{\hat{\tau} + T}{2}$  with  $\hat{\tau} = \max\{\tau_k : \tau_k < T\}$ , and we denote by  $(Z' = (X', Y', P), \Theta')$  the associated state process. It is clear that  $(Z'_s, \Theta'_s) = (Z_s, \Theta_s)$  for  $t \leq s < \tau_m$ , and so  $X'_{(\tau')^-} = X_{(\tau')^-}$ ,  $\Theta'_{(\tau')^-} = \Theta_{(\tau')^-}$ . Moreover, since  $\tau_m = \tau_M$ , we have  $\Theta_{\tau_k^-} = 0$  for  $m + 1 \leq k \leq M$ . From Lemma 3.1 (or Remark 3.1), this implies that  $\zeta_k \leq 0$  for  $m + 1 \leq k \leq M$ , and so  $\zeta'_{N - (M - m) + 1} = \sum_{k=m+1}^M \zeta_k \leq 0$ . We also recall that immediate sales does not increase the cash holdings, so that  $X_{\tau_k} = X_{\tau_m}$  for  $m + 1 \leq k \leq M$ . We then get

$$X'_T = X_T - \zeta'_{N - (M - m) + 1} P_{\tau'} f(\zeta'_{N - (M - m) + 1}, \Theta'_{(\tau')^-}) \geq X_T.$$

Moreover, we have  $Y'_T = y + \sum_{k=1}^N \zeta_k = Y_T = 0$ . By construction, notice that  $\tau'_0 < \dots < \tau'_{m+1}$ . Given an arbitrary  $\alpha \in \tilde{\mathcal{A}}_\ell^b(t, z, \theta)$ , we can then construct by induction a trading

strategy  $\alpha' \in \mathcal{A}_\ell^b(t, z, \theta)$  such that  $X_T' \geq X_T$  a.s. By the nondecreasing monotonicity of the utility function  $U$ , this yields

$$\mathbb{E}[U(X_T)] \leq \mathbb{E}[U(X_T')] \leq v^b(t, z, \theta).$$

Since  $\alpha$  is arbitrary in  $\tilde{\mathcal{A}}_\ell^b(t, z, \theta)$ , we conclude that  $\tilde{v}^b \leq v^b$ , and thus  $v = \bar{v}^b = \tilde{v}^b = v^b$ .

**Step 3.** Fix now an element  $(t, z, \theta) \in [0, T] \times (\bar{\mathcal{S}} \setminus \partial_L \mathcal{S})$ , and denote by  $v_+$  the r.h.s of (3.13). It is clear that  $v \geq v_+$ . Conversely, take some arbitrary  $\alpha = (\tau_k, \zeta_k)_k \in \mathcal{A}_\ell^b(t, z, \theta)$ , associated with the state process  $(Z, \Theta)$ , and denote by  $N = N_T(\alpha)$  the finite number of trading times in  $\alpha$ . Consider the first time before  $T$  when the liquidation value reaches zero, i.e.  $\tau^\alpha = \inf\{t \leq s \leq T : L(Z_s, \Theta_s) = 0\} \wedge T$  with the convention  $\inf \emptyset = \infty$ . We claim that there exists  $1 \leq m \leq N + 1$  (depending on  $\omega$  and  $\alpha$ ) such that  $\tau^\alpha = \tau_m$ , with the convention that  $m = N + 1$ ,  $\tau_{N+1} = T$  if  $\tau^\alpha = T$ . On the contrary, there would exist  $1 \leq k \leq N$  such that  $\tau_k < \tau^\alpha < \tau_{k+1}$ , and  $L(Z_{\tau^\alpha}, \Theta_{\tau^\alpha}) = 0$ . Between  $\tau_k$  and  $\tau_{k+1}$ , there is no trading, and so  $(X_s, Y_s) = (X_{\tau_k}, Y_{\tau_k})$ ,  $\Theta_s = s - \tau_k$  for  $\tau_k \leq s < \tau_{k+1}$ . We then get

$$L(Z_s, \Theta_s) = X_{\tau_k} + Y_{\tau_k} P_s f(-Y_{\tau_k}, s - \tau_k), \quad \tau_k \leq s < \tau_{k+1}. \quad (3.14)$$

Moreover, since  $0 < L(Z_{\tau_k}, \Theta_{\tau_k}) = X_{\tau_k}$ , and  $L(Z_{\tau^\alpha}, \Theta_{\tau^\alpha}) = 0$ , we see with (3.14) for  $s = \tau^\alpha$  that  $Y_{\tau_k} P_{\tau^\alpha} f(-Y_{\tau_k}, \tau^\alpha - \tau_k)$  should necessarily be strictly negative:  $Y_{\tau_k} P_{\tau^\alpha} f(-Y_{\tau_k}, \tau^\alpha - \tau_k) < 0$ , a contradiction with the admissibility conditions and the nonnegative property of  $f$ .

We then have  $\tau^\alpha = \tau_m$  for some  $1 \leq m \leq N + 1$ . Observe that if  $m \leq N$ , i.e.  $L(Z_{\tau_m}, \Theta_{\tau_m}) = 0$ , then  $U(L(Z_T, \Theta_T)) = 0$ . Indeed, suppose that  $Y_{\tau_m} > 0$  and  $m \leq N$ . From the admissibility condition, and by Itô's formula to  $L(Z, \Theta)$  in (3.14) between  $\tau^\alpha$  and  $\tau_{m+1}^-$ , we get

$$\begin{aligned} 0 \leq L(Z_{\tau_{m+1}^-}, \Theta_{\tau_{m+1}^-}) &= L(Z_{\tau_{m+1}^-}, \Theta_{\tau_{m+1}^-}) - L(Z_{\tau^\alpha}, \Theta_{\tau^\alpha}) \\ &= \int_{\tau^\alpha}^{\tau_{m+1}^-} Y_{\tau_m} P_s \left[ \beta(Y_{\tau_m}, s - \tau_m) ds + \sigma f(-Y_{\tau_m}, s - \tau_m) dW_s \right], \end{aligned} \quad (3.15)$$

where  $\beta(y, \theta) = bf(-y, \theta) + \frac{\partial f}{\partial \theta}(-y, \theta)$  is bounded on  $\mathbb{R}_+ \times [0, T]$  by **(H4)**(ii). Since the integrand in the above stochastic integral w.r.t the Brownian motion  $W$  is strictly positive, thus nonzero, we must have  $\tau^\alpha = \tau_{m+1}$ . Otherwise, there is a nonzero probability that the r.h.s. of (3.15) becomes strictly negative, a contradiction with the inequality (3.15).

Hence we get  $Y_{\tau_m} = 0$ , and thus  $L(Z_{\tau_{m+1}^-}, \Theta_{\tau_{m+1}^-}) = X_{\tau_m} = 0$ . From the Markov feature of the model and Corollary 3.1, we then have

$$\mathbb{E} \left[ U \left( L(Z_T, \Theta_T) \right) \middle| \mathcal{F}_{\tau_m} \right] \leq v(\tau_m, Z_{\tau_m}, \Theta_{\tau_m}) = U(X_{\tau_m}) = 0.$$

Since  $U$  is nonnegative, this implies that  $U(L(Z_T, \Theta_T)) = 0$ . Let us next consider the trading strategy  $\alpha' = (\tau'_k, \zeta'_k)_{0 \leq k \leq (m-1)} \in \mathcal{A}$  consisting in following  $\alpha$  until time  $\tau^\alpha$ , and liquidating all stock shares at time  $\tau^\alpha = \tau_{m-1}$ , and defined by:

$$(\tau'_k, \zeta'_k) = \begin{cases} (\tau_k, \zeta_k), & \text{for } 0 \leq k < m - 1 \\ (\tau_{m-1}, -Y_{\tau_{(m-1)}^-}), & \text{for } k = m - 1, \end{cases}$$

and we denote by  $(Z', \Theta')$  the associated state process. It is clear that  $(Z'_s, \Theta'_s) = (Z_s, \Theta_s)$  for  $t \leq s < \tau_{m-1}$ , and so  $L(Z'_s, \Theta'_s) = L(Z_s, \Theta_s) > 0$  for  $t \leq s \leq \tau_{m-1}$ . The liquidation at time  $\tau_{m-1}$  (for  $m \leq N$ ) yields  $X_{\tau_{m-1}} = L(Z_{\tau_{m-1}^-}, \Theta_{\tau_{m-1}^-}) > 0$ , and  $Y_{\tau_{m-1}} = 0$ . Since there is no more trading after time  $\tau_{m-1}$ , the liquidation value for  $\tau_{m-1} \leq s \leq T$  is given by:  $L(Z_s, \Theta_s) = X_{\tau_{m-1}} > 0$ . This shows that  $\alpha' \in \mathcal{A}_{\ell^+}^b(t, z, \theta)$ . When  $m = N + 1$ , we have  $\alpha = \alpha'$ , and so  $X'_T = L(Z'_T, \Theta'_T) = L(Z_T, \Theta_T) = X_T$ . For  $m \leq N$ , we have  $U(X'_T) = U(L(Z'_T, \Theta'_T)) \geq 0 = U(L(Z_T, \Theta_T)) = U(X_T)$ . We then get  $U(X'_T) \geq U(X_T)$  a.s., and so

$$\mathbb{E}[U(X_T)] \leq \mathbb{E}[U(X'_T)] \leq v_+(t, z, \theta).$$

Since  $\alpha$  is arbitrary in  $\bar{\mathcal{A}}_{\ell}^b(t, z, \theta)$ , we conclude that  $v \leq v_+$ , and thus  $v = v_+$ .  $\square$

**Remark 3.2** If we suppose that the function  $e \in \mathbb{R} \mapsto ef(e, \theta)$  is increasing for  $\theta \in (0, T]$ , we get the value of  $v$  on the bound  $\partial_L \mathcal{S}^*$ :  $v(t, z, \theta) = U(0) = 0$  for  $(t, z = (x, y, p), \theta) \in [0, T] \times \partial_L \mathcal{S}^*$ . Indeed, fix some point  $(t, z = (x, y, p), \theta) \in [0, T] \times \partial_L \mathcal{S}^*$ , and consider an arbitrary  $\alpha = (\tau_k, \zeta_k)_k \in \mathcal{A}_{\ell}^b(t, z, \theta)$  with state process  $(Z, \Theta)$ , and denote by  $N$  the number of trading times. We distinguish two cases: (i) If  $\tau_1 = t$ , then by Lemma 3.1, the transaction  $\zeta_1$  is equal to  $-y$ , which leads to  $Y_{\tau_1} = 0$ , and a liquidation value  $L(Z_{\tau_1}, \Theta_{\tau_1}) = X_{\tau_1} = L(z, \theta) = 0$ . At the next trading date  $\tau_2$  (if it exists), we get  $X_{\tau_2^-} = Y_{\tau_2^-} = 0$  with liquidation value  $L(Z_{\tau_2^-}, \Theta_{\tau_2^-}) = 0$ , and by using again Lemma 3.1, we see that after the transaction at  $\tau_2$ , we shall also obtain  $X_{\tau_2} = Y_{\tau_2} = 0$ . By induction, this leads at the final trading time to  $X_{\tau_N} = Y_{\tau_N} = 0$ , and finally to  $X_T = Y_T = 0$ . (ii) If  $\tau_1 > t$ , we claim that  $y = 0$ . On the contrary, by arguing similarly as in (3.15) between  $t$  and  $\tau_1^-$ , we have then proved that any admissible trading strategy  $\alpha \in \mathcal{A}_{\ell}^b(t, z, \theta)$  provides a final liquidation value  $X_T = 0$ , and so

$$v(t, z, \theta) = U(0) = 0, \quad \forall (t, z, \theta) \in [0, T] \times \partial_L \mathcal{S}^*. \quad (3.16)$$

**Comments on Theorem 3.1.** The representation (3.12) of the optimal portfolio liquidation reveals interesting economical and mathematical features. It shows that the liquidation problem in a continuous-time illiquid market model with discrete-time orders and temporary price impact with the presence of a bid-ask spread as considered in this paper, leads to nearly optimal trading strategies with a finite number of orders and with strictly increasing trading times. While most models dealing with trading strategies via an impulse control formulation assumed fixed transaction fees in order to justify the discrete nature of trading times, we prove rigorously in this paper that discrete-time trading appears naturally as a consequence of temporary price impact and bid-ask spread. Although the result is quite intuitive, its proof uses technical argument. In particular the separation of intervention times in Step 2, could not be done in a single step. Indeed, the natural idea consisting in replacing the sequence  $(\tau_{k-1}, \tau_k, \tau_{k+1})$  with  $\tau_{k-1} = \tau_k < \tau_{k+1}$ , by  $(\tau_{k-1}, \tau'_k = \frac{\tau_{k-1} + \tau_{k+1}}{2}, \tau_{k+1})$  is not possible since  $\frac{\tau_{k-1} + \tau_{k+1}}{2}$  is not necessarily a stopping time. We therefore gather all the cumulated orders at the terminal time and we construct a stopping time of the form  $\frac{\tau_N + T}{2}$  where  $\tau_N$  is the last time intervention such that  $\tau_N < T$ . This allows us to obtain a strategy, which provides a better gain and for which the intervention times are separated.

We mention a recent related paper [21], which considers an impulse control problem with subadditive transaction costs where the investor can trade only finitely many times during the trading horizon  $[0, T]$ . In this case, the authors prove that the number of trading times has finite expectation.

The representation (3.13) shows that when we are in an initial state with strictly positive liquidation value, then we can restrict in the optimal portfolio liquidation problem to admissible trading strategies with strictly positive liquidation value up to time  $T^-$ . The relation (3.16) means that when the initial state has a zero liquidation value, which is not a result of an immediate trading time, then the liquidation value will stay at zero until the final horizon.

## 4 Dynamic programming and viscosity properties

In the sequel, the conditions **(H1)**, **(H2)**, **(H3)**, **(H4)** and **(H5)** stand in force, and are not recalled in the statement of Theorems and Propositions.

We use a dynamic programming approach to derive the equation satisfied by the value function of our optimal portfolio liquidation problem. Dynamic programming principle (DPP) for impulse controls was frequently used starting from the works in [4], and then considered e.g. in [32], [24], [20] or [30]. In our context (recall the expression (2.11) of the value function), this is formulated as:

DYNAMIC PROGRAMMING PRINCIPLE (DPP). For all  $(t, z, \theta) \in [0, T] \times \bar{\mathcal{S}}$ , we have

$$v(t, z, \theta) = \sup_{\alpha \in \mathcal{A}(t, z, \theta)} \mathbb{E}[v(\tau, Z_\tau, \Theta_\tau)], \quad (4.1)$$

where  $\tau = \tau(\alpha)$  is any stopping time valued in  $[t, T]$  eventually depending on the strategy  $\alpha$  in (4.1).

The corresponding dynamic programming Hamilton-Jacobi-Bellman (HJB) equation is a quasi-variational inequality (QVI) written as:

$$\min \left[ -\frac{\partial v}{\partial t} - \frac{\partial v}{\partial \theta} - \mathcal{L}v, v - \mathcal{H}v \right] = 0, \quad \text{in } [0, T] \times \bar{\mathcal{S}}, \quad (4.2)$$

together with the relaxed terminal condition:

$$\min [v - U_L, v - \mathcal{H}v] = 0, \quad \text{in } \{T\} \times \bar{\mathcal{S}}. \quad (4.3)$$

The rigorous derivation of the HJB equation satisfied by the value function from the dynamic programming principle is achieved by means of the notion of viscosity solutions, and is by now rather classical in the modern approach of stochastic control (see e.g. the books [13] and [25]). There are some specific features here related to the impulse control and the liquidation state constraint, and we recall in Appendix A, definitions of (discontinuous) constrained viscosity solutions for parabolic QVIs. The first result of this section is stated as follows.

**Proposition 4.1** *The value function  $v$  is a constrained viscosity solution to (4.2)-(4.3).*

The proof of Proposition 4.1 is quite routine following for example arguments in [25] or [8], and is omitted here.

In order to have a complete characterization of the value function through its HJB equation, we usually need a uniqueness result, thus a comparison principle for the QVI (4.2)-(4.3). A key argument originally due to [17] for getting a uniqueness result for variational inequalities with impulse parts, is to produce a strict viscosity supersolution. However, in our model, this is not possible. Indeed, suppose we can find a strict viscosity lsc supersolution  $w$  to (4.2), so that  $(w - \mathcal{H}w)(t, z, \theta) > 0$  on  $[0, T] \times \mathcal{S}$ . But for  $z = (x, y, p)$  and  $\theta = 0$ , we have  $\Gamma(z, 0, e) = (x, y + e, p)$  for any  $e \in \mathcal{C}(z, 0)$ . Since  $0 \in \mathcal{C}(z, 0)$  we have  $\mathcal{H}w(t, z, 0) = \sup_{e \in [-y, 0]} w(t, x, y + e, p, 0) \geq w(t, z, 0) > \mathcal{H}w(t, z, 0)$ , a contradiction. Actually, the main reason why one cannot obtain a strict supersolution is the absence of fixed cost in the impulse function  $\Gamma$  or in the objective functional.

However, we can prove a weaker characterization of the value function in terms of minimal solution to its DPE. The argument is based on a small perturbation of the gain functional. The proof is postponed in Appendix B.

**Proposition 4.2** *The value function  $v$  is the minimal constrained viscosity solution in  $\mathcal{G}_\gamma([0, T] \times \mathcal{S})$  to (4.2)-(4.3), satisfying the boundary condition*

$$\lim_{(t', z', \theta') \rightarrow (t, z, \theta)} v(t', z', \theta') = v(t, z, \theta) = U(0), \quad \forall (t, z, \theta) \in [0, T] \times D_0. \quad (4.4)$$

## 5 An approximating problem with fixed transaction fee

In this section, we consider a small variation of our original model by adding a fixed transaction fee  $\varepsilon > 0$  at each trading. This means that given a trading strategy  $\alpha = (\tau_n, \zeta_n)_{n \geq 0}$ , the controlled state process  $(Z = (X, Y, P), \Theta)$  jumps now at time  $\tau_{n+1}$ , by:

$$(Z_{\tau_{n+1}}, \Theta_{\tau_{n+1}}) = \left( \Gamma_\varepsilon(Z_{\tau_{n+1}}^-, \Theta_{\tau_{n+1}}^-, \zeta_{n+1}), 0 \right), \quad (5.1)$$

where  $\Gamma_\varepsilon$  is the function defined on  $\mathbb{R} \times \mathbb{R}_+ \times \mathbb{R}_+^* \times [0, T] \times \mathbb{R}$  into  $\mathbb{R} \cup \{-\infty\} \times \mathbb{R} \times \mathbb{R}_+^*$  by:

$$\Gamma_\varepsilon(z, \theta, e) = \Gamma(z, \theta, e) - (\varepsilon, 0, 0) = \left( x - epf(e, \theta) - \varepsilon, y + e, p \right),$$

for  $z = (x, y, p)$ . The dynamics of  $(Z, \Theta)$  between trading dates is given as before. We also introduce a modified liquidation function  $L_\varepsilon$  defined by:

$$L_\varepsilon(z, \theta) = \max[x, L(z, \theta) - \varepsilon], \quad (z, \theta) = (x, y, p, \theta) \in \mathbb{R} \times \mathbb{R}_+ \times \mathbb{R}_+^* \times [0, T].$$

The interpretation of this modified liquidation function is the following. Due to the presence of the transaction fee at each trading, it may be advantageous for the investor not to liquidate his position in stock shares (which would give him  $L(z, \theta) - \varepsilon$ ), and rather bin his stock shares, by keeping only his cash amount (which would give him  $x$ ). Hence, the investor chooses the best of these two possibilities, which induces a liquidation value  $L_\varepsilon(z, \theta)$ .

We then introduce the corresponding solvency region  $\mathcal{S}_\varepsilon$  with its closure  $\bar{\mathcal{S}}_\varepsilon = \mathcal{S}_\varepsilon \cup \partial\mathcal{S}_\varepsilon$ , and boundary  $\partial\mathcal{S}_\varepsilon = \partial_y\mathcal{S}_\varepsilon \cup \partial_L\mathcal{S}_\varepsilon$ :

$$\begin{aligned}\mathcal{S}_\varepsilon &= \left\{ (z, \theta) = (x, y, p, \theta) \in \mathbb{R} \times \mathbb{R}_+ \times \mathbb{R}_+^* \times [0, T] : y > 0 \text{ and } L_\varepsilon(z, \theta) > 0 \right\}, \\ \partial_y\mathcal{S}_\varepsilon &= \left\{ (z, \theta) = (x, y, p, \theta) \in \mathbb{R} \times \mathbb{R}_+ \times \mathbb{R}_+^* \times [0, T] : y = 0 \text{ and } L_\varepsilon(z, \theta) \geq 0 \right\}, \\ \partial_L\mathcal{S}_\varepsilon &= \left\{ (z, \theta) = (x, y, p, \theta) \in \mathbb{R} \times \mathbb{R}_+ \times \mathbb{R}_+^* \times \mathbb{R}_+ : L_\varepsilon(z, \theta) = 0 \right\}.\end{aligned}$$

We also introduce the corner lines of  $\partial\mathcal{S}_\varepsilon$ . For simplicity of presentation, we consider a temporary price impact function  $f$  in the form:

$$f(e, \theta) = \tilde{f}\left(\frac{e}{\theta}\right) = \exp\left(\lambda\frac{e}{\theta}\right)\left(\kappa_a\mathbf{1}_{e>0} + \mathbf{1}_{e=0} + \kappa_b\mathbf{1}_{e<0}\right)\mathbf{1}_{\theta>0},$$

where  $0 < \bar{\kappa}_b < 1 < \underline{\kappa}_a$ , and  $\lambda > 0$ . A straightforward analysis of the function  $L$  shows that  $y \mapsto L(x, y, p, \theta)$  is increasing on  $[0, \theta/\lambda]$ , decreasing on  $[\theta/\lambda, \infty)$  with  $L(x, 0, p, \theta) = x = L(x, \infty, p, \theta)$ , and  $\max_{y>0} L(x, y, p, \theta) = L(x, \theta/\lambda, p, \theta) = x + p\frac{\theta}{\lambda}\tilde{f}(-1/\lambda)$ . We first get the form of the sets  $\mathcal{C}(z, \theta)$ :  $\mathcal{C}(z, \theta) = [-y, \bar{e}(z, \theta)]$ , where the function  $\bar{e}$  is defined in Lemma 3.1. We then distinguish two cases: (i) If  $p\frac{\theta}{\lambda}\tilde{f}(-1/\lambda) < \varepsilon$ , then  $L_\varepsilon(x, y, p, \theta) = x$ . (ii) If  $p\frac{\theta}{\lambda}\tilde{f}(-1/\lambda) \geq \varepsilon$ , then there exists a unique  $y_1(p, \theta) \in (0, \theta/\lambda]$  and  $y_2(p, \theta) \in [\theta/\lambda, \infty)$  such that  $L(x, y_1(p, \theta), p, \theta) = L(x, y_2(p, \theta), p, \theta) = x$ , and  $L_\varepsilon(x, y, p, \theta) = x$  for  $y \in [0, y_1(p, \theta)) \cup (y_2(p, \theta), \infty)$ ,  $L_\varepsilon(x, y, p, \theta) = L(x, y, p, \theta) - \varepsilon$  for  $y \in [y_1(p, \theta), y_2(p, \theta)]$ . We then denote by

$$\begin{aligned}D_0 &= \{0\} \times \{0\} \times \mathbb{R}_+^* \times [0, T] = \partial_y\mathcal{S}_\varepsilon \cap \partial_L\mathcal{S}_\varepsilon, \\ D_{1,\varepsilon} &= \left\{ (0, y_1(p, \theta), p, \theta) : p\frac{\theta}{\lambda}\tilde{f}\left(\frac{-1}{\lambda}\right) \geq \varepsilon, \theta \in [0, T] \right\}, \\ D_{2,\varepsilon} &= \left\{ (0, y_2(p, \theta), p, \theta) : p\frac{\theta}{\lambda}\tilde{f}\left(\frac{-1}{\lambda}\right) \geq \varepsilon, \theta \in [0, T] \right\}.\end{aligned}$$

Notice that the inner normal vectors at the corner lines  $D_{1,\varepsilon}$  and  $D_{2,\varepsilon}$  form an acute angle (positive scalar product), while we have a right angle at the corner  $D_0$ . We represent in Figure 4 the graph of  $\mathcal{S}_\varepsilon$  in the plane  $(x, y)$  for different values of  $\varepsilon$ , in Figure 5 the graph of  $\mathcal{S}_\varepsilon$  in the space  $(x, y, p)$ , and in Figure 6 the graph of  $\mathcal{S}_\varepsilon$  in the space  $(x, y, \theta)$ .

Next, we define the set of admissible trading strategies as follows. Given  $(t, z, \theta) \in [0, T] \times \bar{\mathcal{S}}_\varepsilon$ , we say that the impulse control  $\alpha$  is admissible, denoted by  $\alpha \in \mathcal{A}^\varepsilon(t, z, \theta)$ , if  $\tau_0 = t - \theta$ ,  $\tau_n \geq t$ ,  $n \geq 1$ , and the controlled state process  $(Z^\varepsilon, \Theta)$  solution to (2.1)-(2.2)-(2.3)-(2.7)-(5.1), with an initial state  $(Z_{t-}^\varepsilon, \Theta_{t-}) = (z, \theta)$  (and the convention that  $(Z_t^\varepsilon, \Theta_t) = (z, \theta)$  if  $\tau_1 > t$ ), satisfies  $(Z_s^\varepsilon, \Theta_s) \in [0, T] \times \bar{\mathcal{S}}_\varepsilon$  for all  $s \in [t, T]$ . Here, we stress the dependence of  $Z^\varepsilon = (X^\varepsilon, Y, P)$  in  $\varepsilon$  appearing in the transaction function  $\Gamma_\varepsilon$ , and we notice that it affects only the cash component. Notice that  $\mathcal{A}^\varepsilon(t, z, \theta)$  is nonempty for any  $(t, z, \theta) \in [0, T] \times \bar{\mathcal{S}}_\varepsilon$ . Indeed, for  $(z, \theta) \in \bar{\mathcal{S}}_\varepsilon$  with  $z = (x, y, p)$ , i.e.  $L_\varepsilon(z, \theta) = \max(x, L(z, \theta) - \varepsilon) \geq 0$ , we distinguish two cases: (i) if  $x \geq 0$ , then by doing none transaction, the associated state process  $(Z^\varepsilon = (X^\varepsilon, Y, P), \Theta)$  satisfies  $X_s^\varepsilon = x \geq 0$ ,  $t \leq s \leq T$ , and thus this zero transaction is admissible; (ii) if  $L(z, \theta) - \varepsilon \geq 0$ , then by liquidating immediately all the stock shares, and doing nothing more after, the associated state process satisfies  $X_s^\varepsilon = L(z, \theta) - \varepsilon$ ,  $Y_s =$

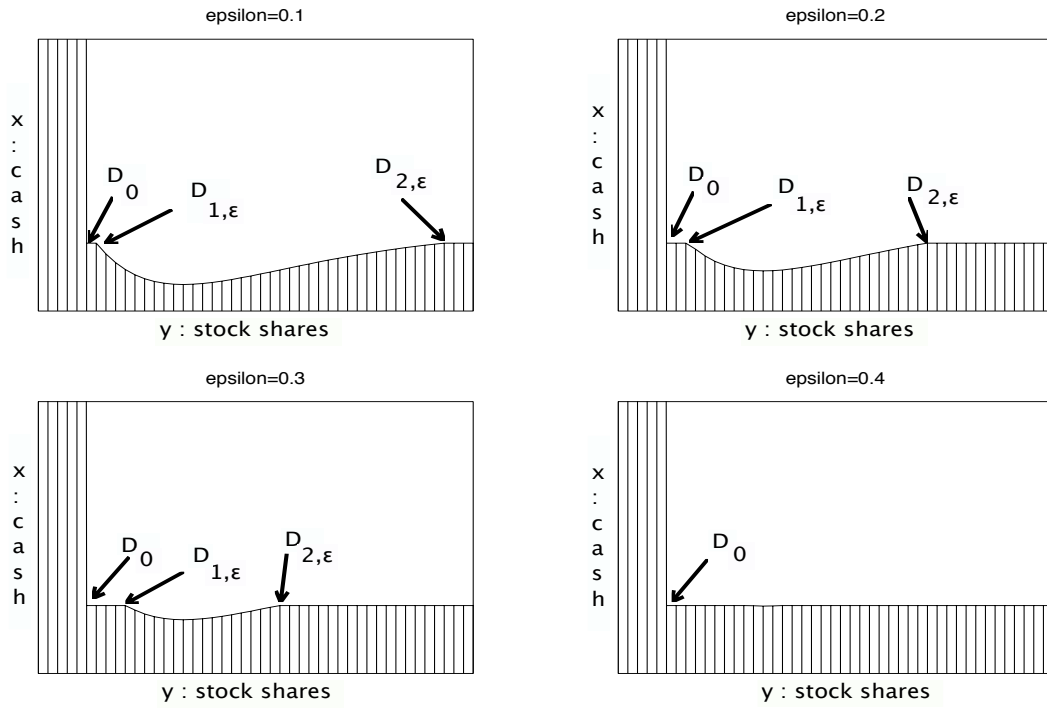

Figure 4: Domain  $\mathcal{S}_\epsilon$  in the nonhatched zone for fixed  $p = 1$  and  $\theta = 1$  and  $\epsilon$  evolving from 0.1 to 0.4. Here  $\kappa_b = 0.9$  and  $f(e, \theta) = \kappa_b \exp\left(\frac{e}{\theta}\right)$  for  $e < 0$ . Notice that for  $\epsilon$  large enough,  $\mathcal{S}_\epsilon$  is equal to open orthant  $\mathbb{R}_+^* \times \mathbb{R}_+^*$ .



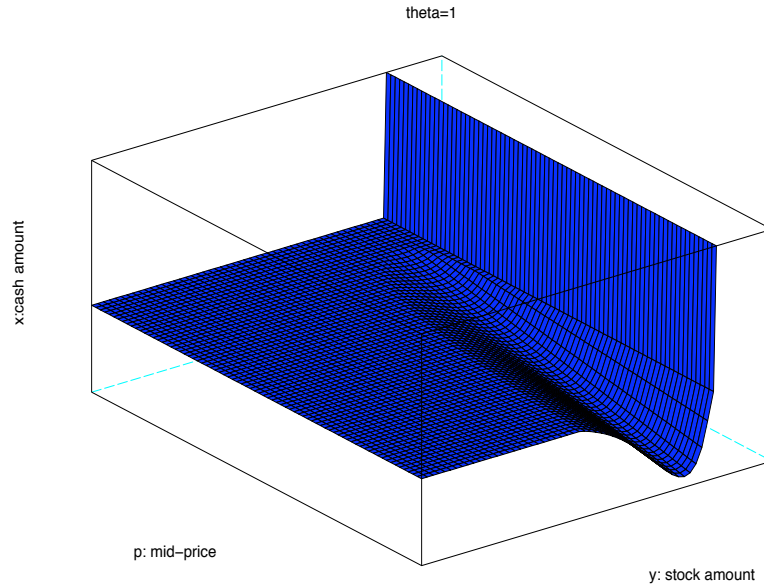

Figure 5: Lower bound of the domain  $\mathcal{S}_\varepsilon$  for fixed  $\theta = 1$  and  $f(e, \theta) = \kappa_b \exp\left(\frac{e}{\theta}\right)$  for  $e < 0$ . Notice that when  $p$  is fixed, we obtain the Figure 4.

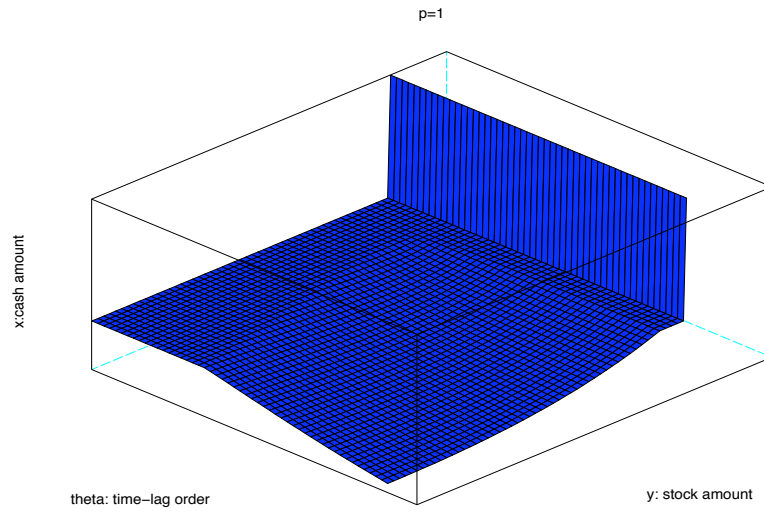

Figure 6: Lower bound of the domain  $\mathcal{S}_\varepsilon$  for fixed  $p = 1$  and  $\varepsilon = 0.2$ . Here  $\kappa_b = 0.9$  and  $f(e, \theta) = \kappa_b \exp\left(\frac{e}{\theta}\right)$  for  $e < 0$ . Notice that when  $\theta$  is fixed, we obtain the Figure 4.

0, and thus  $L_\varepsilon(Z_s^\varepsilon, \Theta_s) = X_s^\varepsilon \geq 0$ ,  $t \leq s \leq T$ , which shows that this immediate transaction is admissible.

Given the utility function  $U$  on  $\mathbb{R}_+$ , and the liquidation utility function defined on  $\bar{\mathcal{S}}_\varepsilon$  by  $U_{L_\varepsilon}(z, \theta) = U(L_\varepsilon(z, \theta))$ , we then consider the associated optimal portfolio liquidation problem defined via its value function by:

$$v_\varepsilon(t, z, \theta) = \sup_{\alpha \in \mathcal{A}^\varepsilon(t, z, \theta)} \mathbb{E}[U_{L_\varepsilon}(Z_T^\varepsilon, \Theta_T)], \quad (t, z, \theta) \in [0, T] \times \bar{\mathcal{S}}_\varepsilon. \quad (5.2)$$

Notice that when  $\varepsilon = 0$ , the above problem reduces to the optimal portfolio liquidation problem described in Section 2, and in particular  $v_0 = v$ . The main purpose of this section is to provide a unique PDE characterization of the value functions  $v_\varepsilon$ ,  $\varepsilon > 0$ , and to prove that the sequence  $(v_\varepsilon)_\varepsilon$  converges to the original value function  $v$  as  $\varepsilon$  goes to zero.

We define the set of admissible transactions in the model with fixed transaction fee by:

$$\mathcal{C}_\varepsilon(z, \theta) = \left\{ e \in \mathbb{R} : \left( \Gamma_\varepsilon(z, \theta, e), 0 \right) \in \bar{\mathcal{S}}_\varepsilon \right\}, \quad (z, \theta) \in \bar{\mathcal{S}}_\varepsilon.$$

A similar calculation as in Lemma 3.1 shows that for  $(z, \theta) \in \bar{\mathcal{S}}_\varepsilon$ ,  $z = (x, y, p)$ ,

$$\mathcal{C}_\varepsilon(z, \theta) = \begin{cases} [-y, \bar{e}_\varepsilon(z, \theta)], & \text{if } \theta > 0 \text{ or } x \geq \varepsilon, \\ \emptyset, & \text{if } \theta = 0 \text{ and } x < \varepsilon, \end{cases}$$

where  $\bar{e}_\varepsilon(z, \theta) = \sup\{e \in \mathbb{R} : ep\tilde{f}(e/\theta) \leq x - \varepsilon\}$  if  $\theta > 0$  and  $\bar{e}_\varepsilon(z, 0) = 0$  if  $x \geq \varepsilon$ . Here, the set  $[-y, \bar{e}_\varepsilon(z, \theta)]$  should be viewed as empty when  $\bar{e}_\varepsilon(z, \theta) < y$ , i.e.  $x + py\tilde{f}(-y/\theta) - \varepsilon < 0$ . We also easily check that  $\mathcal{C}_\varepsilon$  is continuous for the Hausdorff metric. We then consider the impulse operator  $\mathcal{H}_\varepsilon$  by

$$\mathcal{H}_\varepsilon w(t, z, \theta) = \sup_{e \in \mathcal{C}_\varepsilon(z, \theta)} w(t, \Gamma_\varepsilon(z, \theta, e), 0), \quad (t, z, \theta) \in [0, T] \times \bar{\mathcal{S}}_\varepsilon,$$

for any locally bounded function  $w$  on  $[0, T] \times \bar{\mathcal{S}}_\varepsilon$ , with the convention that  $\mathcal{H}_\varepsilon w(t, z, \theta) = -\infty$  when  $\mathcal{C}_\varepsilon(z, \theta) = \emptyset$ .

Next, consider again the Merton liquidation function  $L_M$ , and observe similarly as in (3.7) that

$$\begin{aligned} L_M(\Gamma_\varepsilon(z, \theta, e)) - L_M(z) &= ep(1 - f(e, \theta)) - \varepsilon \\ &\leq -\varepsilon, \quad \forall (z, \theta) \in \bar{\mathcal{S}}_\varepsilon, \quad e \in \mathbb{R}. \end{aligned} \quad (5.3)$$

This implies in particular that

$$\mathcal{H}_\varepsilon L_M < L_M \quad \text{on } \bar{\mathcal{S}}_\varepsilon. \quad (5.4)$$

Since  $L_\varepsilon \leq L_M$ , we observe from (5.3) that if  $(z, \theta) \in \mathcal{N}_\varepsilon := \{(z, \theta) \in \bar{\mathcal{S}}_\varepsilon : L_M(z) < \varepsilon\}$ , then  $\mathcal{C}_\varepsilon(z, \theta) = \emptyset$ . Moreover, we deduce from (5.3) that for all  $\alpha = (\tau_n, \zeta_n)_{n \geq 0} \in \mathcal{A}^\varepsilon(t, z, \theta)$  associated to the state process  $(Z, \Theta)$ ,  $(t, z, \theta) \in [0, T] \times \bar{\mathcal{S}}_\varepsilon$ :

$$\begin{aligned} 0 \leq L_M(Z_T) &= L_M(Z_T^{0,t,z}) + \sum_{n \geq 0} \Delta L_M(Z_{\tau_n}) \\ &\leq L_M(Z_T^{0,t,z}) - \varepsilon N_T(\alpha), \end{aligned}$$

where we recall that  $N_T(\alpha)$  is the number of trading times over the whole horizon  $T$ . This shows that

$$N_T(\alpha) \leq \frac{1}{\varepsilon} L_M(Z_T^{0,t,z}) < \infty \quad a.s.$$

In other words, we see that, under the presence of fixed transaction fee, the number of intervention times over a finite interval for an admissible trading strategy is finite almost surely.

The dynamic programming equation associated to the control problem (5.2) is

$$\min \left[ -\frac{\partial w}{\partial t} - \frac{\partial w}{\partial \theta} - \mathcal{L}w, w - \mathcal{H}_\varepsilon w \right] = 0, \quad \text{in } [0, T] \times \bar{\mathcal{S}}_\varepsilon, \quad (5.5)$$

$$\min [w - U_{L_\varepsilon}, w - \mathcal{H}_\varepsilon w] = 0, \quad \text{in } \{T\} \times \bar{\mathcal{S}}_\varepsilon. \quad (5.6)$$

The main result of this section is stated as follows.

**Theorem 5.1** (1) *The sequence  $(v_\varepsilon)_\varepsilon$  is nonincreasing, and converges pointwise on  $[0, T] \times (\bar{\mathcal{S}} \setminus \partial_L \mathcal{S})$  towards  $v$  as  $\varepsilon$  goes to zero.*

(2) *For any  $\varepsilon > 0$ , the value function  $v_\varepsilon$  is continuous on  $[0, T] \times \mathcal{S}_\varepsilon$ , and is the unique (in  $[0, T] \times \mathcal{S}_\varepsilon$ ) constrained viscosity solution to (5.5)-(5.6), satisfying the growth condition:*

$$|v_\varepsilon(t, z, \theta)| \leq K(1 + L_M(z)^\gamma), \quad \forall (t, z, \theta) \in [0, T] \times \bar{\mathcal{S}}_\varepsilon, \quad (5.7)$$

for some positive constant  $K$ , and the boundary condition:

$$\begin{aligned} \lim_{(t', z', \theta') \rightarrow (t, z, \theta)} v_\varepsilon(t', z', \theta') &= v(t, z, \theta) \\ &= U(0), \quad \forall (t, z = (0, 0, p), \theta) \in [0, T] \times D_0. \end{aligned} \quad (5.8)$$

We first prove rigorously the convergence of the sequence of value functions  $(v_\varepsilon)$ . The proof relies in particular on the discrete-time feature of nearly optimal trading strategies for the original value function  $v$ , see Theorem 3.1. There are technical difficulties related to the dependence on  $\varepsilon$  of the solvency constraint via the liquidation function  $L_\varepsilon$ , when passing to the limit  $\varepsilon \rightarrow 0$ .

**Proof of Theorem 5.1 (1).**

Notice that for any  $0 < \varepsilon_1 \leq \varepsilon_2$ , we have  $L_{\varepsilon_2} \leq L_{\varepsilon_1} \leq L$ ,  $\mathcal{A}^{\varepsilon_2}(t, z, \theta) \subset \mathcal{A}^{\varepsilon_1}(t, z, \theta) \subset \mathcal{A}(t, z, \theta)$ , for  $t \in [0, T]$ ,  $(z, \theta) \in \bar{\mathcal{S}}_{\varepsilon_2} \subset \bar{\mathcal{S}}_{\varepsilon_1} \subset \bar{\mathcal{S}}$ , and for  $\alpha \in \mathcal{A}^{\varepsilon_2}(t, z, \theta)$ ,  $L_{\varepsilon_2}(Z^{\varepsilon_2}, \Theta) \leq L_{\varepsilon_2}(Z^{\varepsilon_1}, \Theta) \leq L_{\varepsilon_1}(Z^{\varepsilon_1}, \Theta) \leq L(Z, \Theta)$ . This shows that the sequence  $(v_\varepsilon)$  is nonincreasing, and is upper-bounded by the value function  $v$  without transaction fee, so that

$$\lim_{\varepsilon \downarrow 0} v_\varepsilon(t, z, \theta) \leq v(t, z, \theta), \quad \forall (t, z, \theta) \in [0, T] \times \bar{\mathcal{S}}. \quad (5.9)$$

Fix now some point  $(t, z, \theta) \in [0, T] \times (\bar{\mathcal{S}} \setminus \partial_L \mathcal{S})$ . From the representation (3.13) of  $v(t, z, \theta)$ , there exists for any  $n \geq 1$ , an  $1/n$ -optimal control  $\alpha^{(n)} = (\tau_k^{(n)}, \zeta_k^{(n)})_k \in \mathcal{A}_{\ell^+}^b(t, z, \theta)$  with associated state process  $(Z^{(n)} = (X^{(n)}, Y^{(n)}, P), \Theta^{(n)})$  and number of trading times  $N^{(n)}$ :

$$\mathbb{E}[U(X_T^{(n)})] \geq v(t, z, \theta) - \frac{1}{n}. \quad (5.10)$$

We denote by  $(Z^{\varepsilon,(n)}, \Theta^{(n)}) = (X^{\varepsilon,(n)}, Y^{(n)}, P), \Theta^{(n)}$  the state process controlled by  $\alpha^{(n)}$  in the model with transaction fee  $\varepsilon$  (only the cash component is affected by  $\varepsilon$ ), and we observe that for all  $t \leq s \leq T$ ,

$$X_s^{\varepsilon,(n)} = X_s^{(n)} - \varepsilon N_s^{(n)} \nearrow X_s^{(n)}, \quad \text{as } \varepsilon \text{ goes to zero.} \quad (5.11)$$

Given  $n$ , we consider the family of stopping times:

$$\sigma_\varepsilon^{(n)} = \inf \{s \geq t : L(Z_s^{\varepsilon,(n)}, \Theta_s^{(n)}) \leq \varepsilon\} \wedge T, \quad \varepsilon > 0.$$

Let us prove that

$$\lim_{\varepsilon \searrow 0} \sigma_\varepsilon^{(n)} = T \text{ a.s.} \quad (5.12)$$

Observe that for  $0 < \varepsilon_1 \leq \varepsilon_2$ ,  $X_s^{\varepsilon_2,(n)} \leq X_s^{\varepsilon_1,(n)}$ , and so  $L(Z_s^{\varepsilon_2,(n)}, \Theta_s) \leq L(Z_s^{\varepsilon_1,(n)}, \Theta_s)$  for  $t \leq s \leq T$ . This implies clearly that the sequence  $(\sigma_\varepsilon^{(n)})_\varepsilon$  is nonincreasing. Since this sequence is bounded by  $T$ , it admits a limit, denoted by  $\sigma_0^{(n)} = \lim_{\varepsilon \downarrow 0} \uparrow \sigma_\varepsilon^{(n)}$ . Now, by definition of  $\sigma_\varepsilon^{(n)}$ , we have  $L(Z_{\sigma_\varepsilon^{(n)}}^{\varepsilon,(n)}, \Theta_{\sigma_\varepsilon^{(n)}}^{(n)}) \leq \varepsilon$ , for all  $\varepsilon > 0$ . By sending  $\varepsilon$  to zero, we then get with (5.11):

$$L(Z_{\sigma_0^{(n)},-}^{(n)}, \Theta_{\sigma_0^{(n)},-}^{(n)}) = 0 \text{ a.s.}$$

Recalling the definition of  $\mathcal{A}_{\ell+}^b(t, z, \theta)$ , this implies that  $\sigma_0^{(n)} = \tau_k^{(n)}$  for some  $k \in \{1, \dots, N^{(n)} + 1\}$  with the convention  $\tau_{N^{(n)}+1}^{(n)} = T$ . If  $k \leq N^{(n)}$ , arguing as in (3.15), we get a contradiction with the solvency constraints. Hence we get  $\sigma_0^{(n)} = T$ .

Consider now the trading strategy  $\tilde{\alpha}^{\varepsilon,(n)} \in \mathcal{A}$  consisting in following  $\alpha^{(n)}$  until time  $\sigma_\varepsilon^{(n)}$  and liquidating all the stock shares at time  $\sigma_\varepsilon^{(n)}$ , i.e.

$$\tilde{\alpha}^{\varepsilon,(n)} = (\tau_k^{(n)}, \zeta_k^{(n)}) \mathbf{1}_{\tau_k < \sigma_\varepsilon^{(n)}} \cup (\sigma_\varepsilon^{(n)}, -Y_{\sigma_\varepsilon^{(n)},-}^{(n)}).$$

We denote by  $(\tilde{Z}^{\varepsilon,(n)} = (\tilde{X}^{\varepsilon,(n)}, \tilde{Y}^{\varepsilon,(n)}, P), \tilde{\Theta}^{\varepsilon,(n)})$  the associated state process in the market with transaction fee  $\varepsilon$ . By construction, we have for all  $t \leq s < \sigma_\varepsilon^{(n)}$ :  $L(\tilde{Z}_s^{\varepsilon,(n)}, \tilde{\Theta}_s^{\varepsilon,(n)}) = L(Z_s^{\varepsilon,(n)}, \Theta_s^{(n)}) \geq \varepsilon$ , and thus  $L_\varepsilon(\tilde{Z}_s^{\varepsilon,(n)}, \tilde{\Theta}_s^{\varepsilon,(n)}) \geq 0$ . At the transaction time  $\sigma_\varepsilon^{(n)}$ , we then have  $\tilde{X}_{\sigma_\varepsilon^{(n)}}^{\varepsilon,(n)} = L(\tilde{Z}_{\sigma_\varepsilon^{(n)},-}^{\varepsilon,(n)}, \tilde{\Theta}_{\sigma_\varepsilon^{(n)},-}^{\varepsilon,(n)}) - \varepsilon = L(Z_{\sigma_\varepsilon^{(n)},-}^{(n)}, \Theta_{\sigma_\varepsilon^{(n)},-}^{(n)}) - \varepsilon$ ,  $\tilde{Y}_{\sigma_\varepsilon^{(n)}}^{\varepsilon,(n)} = 0$ . After time  $\sigma_\varepsilon^{(n)}$ , there is no more transaction in  $\tilde{\alpha}^{\varepsilon,(n)}$ , and so

$$\tilde{X}_s^{\varepsilon,(n)} = \tilde{X}_{\sigma_\varepsilon^{(n)}}^{\varepsilon,(n)} = L(Z_{\sigma_\varepsilon^{(n)},-}^{(n)}, \Theta_{\sigma_\varepsilon^{(n)},-}^{(n)}) - \varepsilon \geq 0, \quad (5.13)$$

$$\tilde{Y}_s^{\varepsilon,(n)} = \tilde{Y}_{\sigma_\varepsilon^{(n)}}^{\varepsilon,(n)} = 0, \quad \sigma_\varepsilon^{(n)} \leq s \leq T, \quad (5.14)$$

and thus  $L_\varepsilon(\tilde{Z}_s^{\varepsilon,(n)}, \tilde{\Theta}_s^{\varepsilon,(n)}) = \tilde{X}_s^{\varepsilon,(n)} \geq 0$  for  $\sigma_\varepsilon^{(n)} \leq s \leq T$ . This shows that  $\tilde{\alpha}^{\varepsilon,(n)}$  lies in  $\mathcal{A}^\varepsilon(t, z, \theta)$ , and thus by definition of  $v_\varepsilon$ :

$$v_\varepsilon(t, z) \geq \mathbb{E}[U_{L_\varepsilon}(\tilde{Z}_T^{\varepsilon,(n)}, \tilde{\Theta}_T^{\varepsilon,(n)})]. \quad (5.15)$$

Let us check that given  $n$ ,

$$\lim_{\varepsilon \downarrow 0} L_\varepsilon(\tilde{Z}_T^{\varepsilon,(n)}, \tilde{\Theta}_T^{\varepsilon,(n)}) = X_T^{(n)}, \quad a.s. \quad (5.16)$$

To alleviate notations, we set  $N = N_T^{(n)}$  the total number of trading times of  $\alpha^{(n)}$ . If the last trading time of  $\alpha^{(n)}$  occurs strictly before  $T$ , then we do not trade anymore until the final horizon  $T$ , and so

$$X_T^{(n)} = X_{\tau_N}^{(n)}, \quad \text{and} \quad Y_T^{(n)} = Y_{\tau_N}^{(n)} = 0, \quad \text{on} \quad \{\tau_N < T\}. \quad (5.17)$$

By (5.12), we have for  $\varepsilon$  small enough:  $\sigma_\varepsilon^{(n)} > \tau_N$ , and so  $\tilde{X}_{\sigma_\varepsilon^{(n)},-}^{\varepsilon,(n)} = X_{\tau_N}^{\varepsilon,(n)}$ ,  $\tilde{Y}_{\sigma_\varepsilon^{(n)},-}^{\varepsilon,(n)} = Y_{\tau_N}^{(n)} = 0$ . The final liquidation at time  $\sigma_\varepsilon^{(n)}$  yields:  $\tilde{X}_T^{\varepsilon,(n)} = \tilde{X}_{\sigma_\varepsilon^{(n)}}^{\varepsilon,(n)} = \tilde{X}_{\sigma_\varepsilon^{(n)},-}^{\varepsilon,(n)} - \varepsilon = X_{\tau_N}^{\varepsilon,(n)} - \varepsilon$ , and  $\tilde{Y}_T^{\varepsilon,(n)} = \tilde{Y}_{\sigma_\varepsilon^{(n)}}^{\varepsilon,(n)} = 0$ . We then obtain

$$\begin{aligned} L_\varepsilon(\tilde{Z}_T^{\varepsilon,(n)}, \tilde{\Theta}_T^{\varepsilon,(n)}) &= \max\left(\tilde{X}_T^{\varepsilon,(n)}, L(\tilde{Z}_T^{\varepsilon,(n)}, \tilde{\Theta}_T^{\varepsilon,(n)}) - \varepsilon\right) \\ &= \tilde{X}_T^{\varepsilon,(n)} = X_{\tau_N}^{\varepsilon,(n)} - \varepsilon \quad \text{on} \quad \{\tau_N < T\} \\ &= X_T^{(n)} - (1 + N)\varepsilon \quad \text{on} \quad \{\tau_N < T\}, \end{aligned}$$

by (5.11) and (5.17), which shows that the convergence in (5.16) holds on  $\{\tau_N < T\}$ . If the last trading of  $\alpha^{(n)}$  occurs at time  $T$ , this means that we liquidate all stock shares at  $T$ , and so

$$X_T^{(n)} = L(Z_{T-}^{(n)}, \Theta_{T-}^{(n)}), \quad Y_T^{(n)} = 0 \quad \text{on} \quad \{\tau_N = T\}. \quad (5.18)$$

On the other hand, by (5.13)-(5.14), we have

$$\begin{aligned} L_\varepsilon(\tilde{Z}_T^{\varepsilon,(n)}, \tilde{\Theta}_T^{\varepsilon,(n)}) = \tilde{X}_T^{\varepsilon,(n)} &= L(Z_{\sigma_\varepsilon^{(n)},-}^{(n)}, \Theta_{\sigma_\varepsilon^{(n)},-}^{(n)}) - \varepsilon \\ &\longrightarrow L(Z_{T-}^{(n)}, \Theta_{T-}^{(n)}) \quad \text{as } \varepsilon \text{ goes to zero,} \end{aligned}$$

by (5.12). Together with (5.18), this implies that the convergence in (5.16) also holds on  $\{\tau_N = T\}$ , and thus almost surely. Since  $0 \leq L_\varepsilon \leq L$ , we immediately see by Proposition 3.1 that the sequence  $\{U_{L_\varepsilon}(\tilde{Z}_T^{\varepsilon,(n)}, \tilde{\Theta}_T^{\varepsilon,(n)}), \varepsilon > 0\}$  is uniformly integrable, so that by sending  $\varepsilon$  to zero in (5.15) and using (5.16), we get

$$\lim_{\varepsilon \downarrow 0} v_\varepsilon(t, z, \theta) \geq \mathbb{E}[U(X_T^{(n)})] \geq v(t, z) - \frac{1}{n},$$

from (5.10). By sending  $n$  to infinity, and recalling (5.9), this completes the proof of assertion (1) in Theorem 5.1.  $\square$

We now turn to the viscosity characterization of  $v_\varepsilon$ . The viscosity property of  $v_\varepsilon$  is proved similarly as for  $v$ , and is also omitted. From Proposition 3.1, and since  $0 \leq v_\varepsilon \leq v$ , we know that the value functions  $v_\varepsilon$  lie in the set of functions satisfying the growth condition in (5.7), i.e.

$$\mathcal{G}_\gamma([0, T] \times \bar{\mathcal{S}}_\varepsilon) = \left\{ w : [0, T] \times \bar{\mathcal{S}}_\varepsilon \rightarrow \mathbb{R}, \sup_{[0, T] \times \bar{\mathcal{S}}_\varepsilon} \frac{|w(t, z, \theta)|}{1 + L_M(z)^\gamma} < \infty \right\}.$$

The boundary property (5.8) is immediate. Indeed, fix  $(t, z = (x, 0, p), \theta) \in [0, T] \times \partial_y \mathcal{S}_\varepsilon$ , and consider an arbitrary sequence  $(t_n, z_n = (x_n, y_n, p_n), \theta_n)_n$  in  $[0, T] \times \bar{\mathcal{S}}_\varepsilon$  converging to  $(t, z, \theta)$ . Since  $0 \leq L_\varepsilon(z_n, \theta_n) = \max(x_n, L(z_n, \theta_n) - \varepsilon)$ , and  $y_n$  goes to zero, this implies that for  $n$  large enough,  $x_n = L_\varepsilon(z_n, \theta_n) \geq 0$ . By considering from  $(t_n, z_n, \theta_n)$  the admissible strategy of doing none transaction, which leads to a final liquidation value  $X_T = x_n$ , we have  $U(x_n) \leq v_\varepsilon(t_n, z_n, \theta_n) \leq v(t_n, z_n, \theta_n)$ . Recalling Corollary 3.1, we then obtain the continuity of  $v_\varepsilon$  on  $\partial_y \mathcal{S}_\varepsilon$  with  $v_\varepsilon(t, z, \theta) = U(x) = v(t, z, \theta)$  for  $(z, \theta) = (x, 0, p, \theta) \in \partial_y \mathcal{S}_\varepsilon$ , and in particular (5.8). Finally, we address the uniqueness issue, which is a direct consequence of the following comparison principle for constrained (discontinuous) viscosity solution to (5.5)-(5.6).

**Theorem 5.2** (*Comparison principle*)

Suppose  $u \in \mathcal{G}_\gamma([0, T] \times \bar{\mathcal{S}}_\varepsilon)$  is a usc viscosity subsolution to (5.5)-(5.6) on  $[0, T] \times \bar{\mathcal{S}}_\varepsilon$ , and  $w \in \mathcal{G}_\gamma([0, T] \times \bar{\mathcal{S}}_\varepsilon)$  is a lsc viscosity supersolution to (5.5)-(5.6) on  $[0, T] \times \bar{\mathcal{S}}_\varepsilon$  such that

$$u(t, z, \theta) \leq \liminf_{\substack{(t', z', \theta') \rightarrow (t, z, \theta) \\ (t', z', \theta') \in [0, T] \times \mathcal{S}_\varepsilon}} w(t', z', \theta'), \quad \forall (t, z, \theta) \in [0, T] \times D_0. \quad (5.19)$$

Then,

$$u \leq w \quad \text{on} \quad [0, T] \times \bar{\mathcal{S}}_\varepsilon. \quad (5.20)$$

Notice that with respect to usual comparison principles for parabolic PDEs where we compare a viscosity subsolution and a viscosity supersolution from the inequalities on the domain and at the terminal date, we require here in addition a comparison on the boundary  $D_0$  due to the non smoothness of the domain  $\bar{\mathcal{S}}_\varepsilon$  on this right angle of the boundary. A similar feature appears also in [20], and we shall only emphasize the main arguments adapted from [3], for proving the comparison principle.

**Proof of Theorem 5.2.**

Let  $u$  and  $w$  as in Theorem 5.2, and (re)define  $w$  on  $[0, T] \times \partial \mathcal{S}_\varepsilon$  by

$$w(t, z, \theta) = \liminf_{\substack{(t', z', \theta') \rightarrow (t, z, \theta) \\ (t', z', \theta') \in [0, T] \times \mathcal{S}_\varepsilon}} w(t', z', \theta'), \quad (t, z, \theta) \in [0, T] \times \partial \mathcal{S}_\varepsilon. \quad (5.21)$$

In order to obtain the comparison result (5.20), it suffices to prove that  $\sup_{[0, T] \times \bar{\mathcal{S}}_\varepsilon} (u - w) \leq 0$ , and we shall argue by contradiction by assuming that

$$\sup_{[0, T] \times \bar{\mathcal{S}}_\varepsilon} (u - w) > 0. \quad (5.22)$$

- *Step 1. Construction of a strict viscosity supersolution.*

Consider the function defined on  $[0, T] \times \bar{\mathcal{S}}_\varepsilon$  by

$$\psi(t, z, \theta) = e^{\rho'(T-t)} L_M(z)^{\gamma'}, \quad t \in [0, T], (z, \theta) = (x, y, p, \theta) \in \bar{\mathcal{S}}_\varepsilon,$$

where  $\rho' > 0$ , and  $\gamma' \in (0, 1)$  will be chosen later. The function  $\psi$  is smooth  $C^2$  on  $[0, T] \times (\bar{\mathcal{S}}_\varepsilon \setminus D_0)$ , and by the same calculations as in (3.10), we see that by choosing  $\rho' > \frac{\gamma'}{1-\gamma'} \frac{b^2}{2\sigma^2}$ , then

$$-\frac{\partial \psi}{\partial t} - \frac{\partial \psi}{\partial \theta} - \mathcal{L}\psi > 0 \quad \text{on} \quad [0, T] \times (\bar{\mathcal{S}}_\varepsilon \setminus D_0). \quad (5.23)$$

Moreover, from (5.4), we have

$$\begin{aligned} (\psi - \mathcal{H}_\varepsilon \psi)(t, z, \theta) &= e^{\rho'(T-t)} \left[ L_M(z)^{\gamma'} - (\mathcal{H}_\varepsilon L_M(z))^{\gamma'} \right] =: \Delta(t, z) \\ &> 0 \quad \text{on } [0, T] \times \bar{\mathcal{S}}_\varepsilon. \end{aligned} \quad (5.24)$$

For  $m \geq 1$ , we denote by

$$\tilde{u}(t, z, \theta) = e^t u(t, z, \theta), \quad \text{and} \quad \tilde{w}_m(t, z, \theta) = e^t \left[ w(t, z, \theta) + \frac{1}{m} \psi(t, z, \theta) \right].$$

From the viscosity subsolution property of  $u$ , we immediately see that  $\tilde{u}$  is a viscosity subsolution to

$$\min \left[ \tilde{u} - \frac{\partial \tilde{u}}{\partial t} - \frac{\partial \tilde{u}}{\partial \theta} - \mathcal{L} \tilde{u}, \tilde{u} - \mathcal{H}_\varepsilon \tilde{u} \right] \leq 0, \quad \text{on } [0, T] \times \bar{\mathcal{S}}_\varepsilon \quad (5.25)$$

$$\min \left[ \tilde{u} - \tilde{U}_{L_\varepsilon}, \tilde{u} - \mathcal{H}_\varepsilon \tilde{u} \right] \leq 0, \quad \text{on } \{T\} \times \bar{\mathcal{S}}_\varepsilon, \quad (5.26)$$

where we set  $\tilde{U}_{L_\varepsilon}(z, \theta) = e^T U_{L_\varepsilon}(z, \theta)$ . From the viscosity supersolution property of  $w$ , and the relations (5.23)-(5.24), we also derive that  $\tilde{w}_m$  is a viscosity supersolution to

$$\tilde{w}_m - \frac{\partial \tilde{w}_m}{\partial t} - \frac{\partial \tilde{w}_m}{\partial \theta} - \mathcal{L} \tilde{w}_m \geq 0 \quad \text{on } [0, T] \times (\mathcal{S}_\varepsilon \setminus D_0) \quad (5.27)$$

$$\tilde{w}_m - \mathcal{H}_\varepsilon \tilde{w}_m \geq \frac{1}{m} \Delta \quad \text{on } [0, T] \times \mathcal{S}_\varepsilon. \quad (5.28)$$

$$\tilde{w}_m - \tilde{U}_{L_\varepsilon} \geq 0 \quad \text{on } \{T\} \times \mathcal{S}_\varepsilon. \quad (5.29)$$

On the other hand, from the growth condition on  $u$  and  $w$  in  $\mathcal{G}_\gamma([0, T] \times \bar{\mathcal{S}}_\varepsilon)$ , and by choosing  $\gamma' \in (\gamma, 1)$ , we have for all  $(t, \theta) \in [0, T]^2$ ,

$$\lim_{|z| \rightarrow \infty} (u - w_m)(t, z, \theta) = -\infty.$$

Therefore, the usc function  $\tilde{u} - \tilde{w}_m$  attains its supremum on  $[0, T] \times \bar{\mathcal{S}}_\varepsilon$ , and from (5.22), there exists  $m$  large enough, and  $(\bar{t}, \bar{z}, \bar{\theta}) \in [0, T] \times \bar{\mathcal{S}}_\varepsilon$  s.t.

$$\tilde{M} = \sup_{[0, T] \times \bar{\mathcal{S}}_\varepsilon} (\tilde{u} - \tilde{w}_m) = (\tilde{u} - \tilde{w}_m)(\bar{t}, \bar{z}, \bar{\theta}) > 0. \quad (5.30)$$

• *Step 2.* From the boundary condition (5.19), we know that  $(\bar{z}, \bar{\theta})$  cannot lie in  $D_0$ , and we have then two possible cases:

(i)  $(\bar{z}, \bar{\theta}) \in \mathcal{S}_\varepsilon \setminus D_0$

(ii)  $(\bar{z}, \bar{\theta}) \in \partial \mathcal{S}_\varepsilon \setminus D_0$ .

The case (i) where  $(\bar{z}, \bar{\theta})$  lies in  $\mathcal{S}_\varepsilon$  is standard in the comparison principle for (nonconstrained) viscosity solutions, and we focus here on the case (ii), which is specific to constrained viscosity solutions. From (5.21), there exists a sequence  $(t_n, z_n, \theta_n)_{n \geq 1}$  in  $[0, T] \times \mathcal{S}_\varepsilon$  such that

$$(t_n, z_n, \theta_n, \tilde{w}_m(t_n, z_n, \theta_n)) \longrightarrow (\bar{t}, \bar{z}, \bar{\theta}, \tilde{w}_m(\bar{t}, \bar{z}, \bar{\theta})) \quad \text{as } n \rightarrow \infty.$$

We then set  $\delta_n = |z_n - \bar{z}| + |\theta_n - \bar{\theta}|$ , and consider the function  $\Phi_n$  defined on  $[0, T] \times (\bar{\mathcal{S}}_\varepsilon)^2$  by:

$$\begin{aligned}\Phi_n(t, z, \theta, z', \theta') &= \tilde{u}(t, z, \theta) - \tilde{w}_m(t, z', \theta') - \varphi_n(t, z, \theta, z', \theta') \\ \varphi_n(t, z, \theta, z', \theta') &= |t - \bar{t}|^2 + |z - \bar{z}|^4 + |\theta - \bar{\theta}|^4 \\ &\quad + \frac{|z - z'|^2 + |\theta - \theta'|^2}{2\delta_n} + \left( \frac{d(z', \theta')}{d(z_n, \theta_n)} - 1 \right)^4.\end{aligned}$$

Here,  $d(z, \theta)$  denotes the distance from  $(z, \theta)$  to  $\partial\mathcal{S}_\varepsilon$ . Since  $(\bar{z}, \bar{\theta}) \notin D_0$ , there exists an open neighborhood  $\bar{\mathcal{V}}$  of  $(\bar{z}, \bar{\theta})$  satisfying  $\bar{\mathcal{V}} \cap D_0 = \emptyset$ , such that the function  $d(\cdot)$  is twice continuously differentiable with bounded derivatives. This is well known (see e.g. [14]) when  $(\bar{z}, \bar{\theta})$  lies in the smooth parts of the boundary  $\partial\mathcal{S}_\varepsilon \setminus (D_{1,\varepsilon} \cup D_{2,\varepsilon})$ . This is also true for  $(\bar{z}, \bar{\theta}) \in D_{k,\varepsilon}$  for  $k \in \{1, 2\}$ . Indeed, at these corner lines, the inner normal vectors form an acute angle (positive scalar product), and thus one can extend from  $(\bar{z}, \bar{\theta})$  the boundary to a smooth boundary so that the distance  $d$  is equal, locally on the neighborhood, to the distance to this smooth boundary. From the growth conditions on  $u$  and  $w$  in  $\mathcal{G}_\gamma([0, T] \times \bar{\mathcal{S}}_\varepsilon)$ , there exists a sequence  $(\hat{t}_n, \hat{z}_n, \hat{\theta}_n, \hat{z}'_n, \hat{\theta}'_n)$  attaining the maximum of the usc  $\Phi_n$  on  $[0, T] \times (\bar{\mathcal{S}}_\varepsilon)^2$ . By standard arguments (see e.g. [3] or [20]), we have

$$(\hat{t}_n, \hat{z}_n, \hat{\theta}_n, \hat{z}'_n, \hat{\theta}'_n) \longrightarrow (\bar{t}, \bar{z}, \bar{\theta}, \bar{z}, \bar{\theta}) \quad (5.31)$$

$$\frac{|\hat{z}_n - \hat{z}'_n|^2 + |\hat{\theta}_n - \hat{\theta}'_n|^2}{2\delta_n} + \left( \frac{d(\hat{z}'_n, \hat{\theta}'_n)}{d(z_n, \theta_n)} - 1 \right)^4 \longrightarrow 0 \quad (5.32)$$

$$\tilde{u}(\hat{t}_n, \hat{z}_n, \hat{\theta}_n) - \tilde{w}_m(\hat{t}_n, \hat{z}'_n, \hat{\theta}'_n) \longrightarrow (\tilde{u} - \tilde{w}_m)(\bar{t}, \bar{z}, \bar{\theta}). \quad (5.33)$$

The convergence in (5.32) shows in particular that for  $n$  large enough,  $d(\hat{z}'_n, \hat{\theta}'_n) \geq d(z_n, \theta_n)/2 > 0$ , and so  $(\hat{z}'_n, \hat{\theta}'_n) \in \mathcal{S}_\varepsilon$ . From the convergence in (5.31), we may also assume that for  $n$  large enough,  $(\hat{z}_n, \hat{\theta}_n), (\hat{z}'_n, \hat{\theta}'_n)$  lie in the neighborhood  $\bar{\mathcal{V}}$  of  $(\bar{z}, \bar{\theta})$  so that the derivatives upon order 2 of  $d(\cdot)$  at  $(\hat{z}_n, \hat{\theta}_n)$  and  $(\hat{z}'_n, \hat{\theta}'_n)$  exist and are bounded.

• *Step 3.* By similar arguments as in [20], we show that for  $n$  large enough,  $\hat{t}_n < T$ , and

$$\tilde{u}(\hat{t}_n, \hat{z}_n, \hat{\theta}_n) - \mathcal{H}_\varepsilon \tilde{u}(\hat{t}_n, \hat{z}_n) > 0. \quad (5.34)$$

• *Step 4.* We use the viscosity subsolution property (5.25) of  $\tilde{u}$  at  $(\hat{t}_n, \hat{z}_n, \hat{\theta}_n) \in [0, T] \times \bar{\mathcal{S}}_\varepsilon$ , which is written by (5.34) as

$$\left( \tilde{u} - \frac{\partial \tilde{u}}{\partial t} - \frac{\partial \tilde{u}}{\partial \theta} - \mathcal{L}\tilde{u} \right)(\hat{t}_n, \hat{z}_n, \hat{\theta}_n) \leq 0. \quad (5.35)$$

The above inequality is understood in the viscosity sense, and applied with the test function  $(t, z, \theta) \mapsto \varphi_n(t, z, \theta, \hat{z}'_n, \hat{\theta}'_n)$ , which is  $C^2$  in the neighborhood  $[0, T] \times \bar{\mathcal{V}}$  of  $(\hat{t}_n, \hat{z}_n, \hat{\theta}_n)$ . We also write the viscosity supersolution property (5.27) of  $\tilde{w}_m$  at  $(\hat{t}_n, \hat{z}'_n, \hat{\theta}'_n) \in [0, T] \times (\mathcal{S}_\varepsilon \setminus D_0)$ :

$$\left( \tilde{w}_m - \frac{\partial \tilde{w}_m}{\partial t} - \frac{\partial \tilde{w}_m}{\partial \theta} - \mathcal{L}\tilde{w}_m \right)(\hat{t}_n, \hat{z}'_n, \hat{\theta}'_n) \geq 0. \quad (5.36)$$

The above inequality is again understood in the viscosity sense, and applied with the test function  $(t, z', \theta') \mapsto -\varphi_n(t, \hat{z}_n, \hat{\theta}_n, z', \theta')$ , which is  $C^2$  in the neighborhood  $[0, T] \times \bar{\mathcal{V}}$  of  $(\hat{t}_n, \hat{z}'_n, \hat{\theta}'_n)$ . The conclusion is achieved by arguments similar to [20]: we invoke Ishii's Lemma, subtract the two inequalities (5.35)-(5.36), and finally get the required contradiction  $\tilde{M} \leq 0$  by sending  $n$  to infinity with (5.31)-(5.32)-(5.33).  $\square$



## Appendix A: constrained viscosity solutions to parabolic QVIs

We consider a parabolic quasi-variational inequality in the form:

$$\min \left[ -\frac{\partial v}{\partial t} + F(t, x, v, D_x v, D_x^2 v), v - \mathcal{H}v \right] = 0, \quad \text{in } [0, T] \times \bar{\mathcal{O}}, \quad (\text{A.1})$$

together with a terminal condition

$$\min [v - g, v - \mathcal{H}v] = 0, \quad \text{in } \{T\} \times \bar{\mathcal{O}}. \quad (\text{A.2})$$

Here,  $\mathcal{O} \subset \mathbb{R}^d$  is an open domain,  $F$  is a continuous function on  $[0, T] \times \mathbb{R}^d \times \mathbb{R} \times \mathbb{R}^d \times \mathcal{S}^d$  ( $\mathcal{S}^d$  is the set of positive semidefinite symmetric matrices in  $\mathbb{R}^{d \times d}$ ), nonincreasing in its last argument,  $g$  is a continuous function on  $\bar{\mathcal{O}}$ , and  $\mathcal{H}$  is a nonlocal operator defined on the set of locally bounded functions on  $[0, T] \times \bar{\mathcal{O}}$  by:

$$\mathcal{H}v(t, x) = \sup_{e \in \mathcal{C}(t, x)} [v(t, \Gamma(t, x, e)) + c(t, x, e)].$$

$\mathcal{C}(t, x)$  is a compact set of a metric space  $E$ , eventually empty for some values of  $(t, x)$ , in which case we set  $\mathcal{H}v(t, x) = -\infty$ , and is continuous for the Hausdorff metric, i.e. if  $(t_n, x_n)$  converges to  $(t, x)$  in  $[0, T] \times \bar{\mathcal{O}}$ , and  $(e_n)$  is a sequence in  $\mathcal{C}(t_n, x_n)$  converging to  $e$ , then  $e \in \mathcal{C}(t, x)$ . The functions  $\Gamma$  and  $c$  are continuous, and such that  $\Gamma(t, x, e) \in \bar{\mathcal{O}}$  for all  $e \in \mathcal{C}(t, x, e)$ .

Given a locally bounded function  $u$  on  $[0, T] \times \bar{\mathcal{O}}$ , we define its lower-semicontinuous (lsc in short) envelope  $u_*$  and upper-semicontinuous (usc) envelope  $u^*$  on  $[0, T] \times \bar{\mathcal{S}}$  by:

$$u_*(t, x) = \liminf_{\substack{(t', x') \rightarrow (t, x) \\ (t', x') \in [0, T] \times \mathcal{O}}} u(t', x'), \quad u^*(t, x) = \limsup_{\substack{(t', x') \rightarrow (t, x) \\ (t', x') \in [0, T] \times \mathcal{O}}} u(t', x').$$

One can check (see e.g. Lemma 5.1 in [20]) that the operator  $\mathcal{H}$  preserves lower and upper-semicontinuity:

$$(i) \quad \mathcal{H}u_* \text{ is lsc, and } \mathcal{H}u_* \leq (\mathcal{H}u)_*, \quad (ii) \quad \mathcal{H}u^* \text{ is usc, and } (\mathcal{H}u)^* \leq \mathcal{H}u^*. \quad (\text{A.3})$$

We now give the definition of constrained viscosity solutions to (A.1)-(A.2). This notion, which extends the definition of viscosity solutions of Crandall, Ishii and Lions (see [11]), was introduced in [31] for first-order equations for taking into account boundary conditions arising in state constraints, and used in [33] for stochastic control problems in optimal investment.

**Definition A.1** *A locally bounded function  $v$  on  $[0, T] \times \bar{\mathcal{O}}$  is a constrained viscosity solution to (A.1)-(A.2) if the two following properties hold:*

(i) *Viscosity supersolution property on  $[0, T] \times \mathcal{O}$ : for all  $(\bar{t}, \bar{x}) \in [0, T] \times \mathcal{O}$ , and  $\varphi \in C^{1,2}([0, T] \times \mathcal{O})$  with  $0 = (v_* - \varphi)(\bar{t}, \bar{x}) = \min(v_* - \varphi)$ , we have*

$$\begin{aligned} \min \left[ -\frac{\partial \varphi}{\partial t}(\bar{t}, \bar{x}) + F(\bar{t}, \bar{x}, \varphi_*(\bar{t}, \bar{x}), D_x \varphi(\bar{t}, \bar{x}), D_x^2 \varphi(\bar{t}, \bar{x})), \right. \\ \left. v_*(\bar{t}, \bar{x}) - \mathcal{H}v_*(\bar{t}, \bar{x}) \right] \geq 0, \quad (\bar{t}, \bar{x}) \in [0, T] \times \mathcal{O}, \\ \min [v_*(\bar{t}, \bar{x}) - g(\bar{x}), v_*(\bar{t}, \bar{x}) - \mathcal{H}v_*(\bar{t}, \bar{x})] \geq 0, \quad (\bar{t}, \bar{x}) \in \{T\} \times \mathcal{O}. \end{aligned}$$

(ii) *Viscosity subsolution property on  $[0, T] \times \bar{\mathcal{O}}$ : for all  $(\bar{t}, \bar{x}) \in [0, T] \times \bar{\mathcal{O}}$ , and  $\varphi \in C^{1,2}([0, T] \times \bar{\mathcal{O}})$  with  $0 = (v^* - \varphi)(\bar{t}, \bar{x}) = \max(v^* - \varphi)$ , we have*

$$\begin{aligned} \min \left[ -\frac{\partial \varphi}{\partial t}(\bar{t}, \bar{x}) + F(\bar{t}, \bar{x}, \varphi_*(\bar{t}, \bar{x}), D_x \varphi(\bar{t}, \bar{x}), D_x^2 \varphi(\bar{t}, \bar{x})), \right. \\ \left. v^*(\bar{t}, \bar{x}) - \mathcal{H}v^*(\bar{t}, \bar{x}) \right] \leq 0, \quad (\bar{t}, \bar{x}) \in [0, T] \times \bar{\mathcal{O}}, \\ \min [v^*(\bar{t}, \bar{x}) - g(\bar{x}), v^*(\bar{t}, \bar{x}) - \mathcal{H}v^*(\bar{t}, \bar{x})] \leq 0, \quad (\bar{t}, \bar{x}) \in \{T\} \times \bar{\mathcal{O}}. \end{aligned}$$

## Appendix B: proof of Proposition 4.2

We consider a small perturbation of our initial optimization problem by adding a cost  $\varepsilon$  to the utility at each trading. We then define the value function  $\bar{v}_\varepsilon$  on  $[0, T] \times \bar{\mathcal{S}}$  by

$$\bar{v}_\varepsilon(t, z, \theta) = \sup_{\alpha \in \mathcal{A}_\ell^b(t, z, \theta)} \mathbb{E} \left[ U_L(Z_T, \Theta_T) - \varepsilon N_T(\alpha) \right], \quad (t, z, \theta) \in [0, T] \times \bar{\mathcal{S}}. \quad (\text{B.1})$$

**Step 1.** We first prove that the sequence  $(\bar{v}_\varepsilon)_\varepsilon$  converges pointwise on  $[0, T] \times \bar{\mathcal{S}}$  towards  $v$  as  $\varepsilon$  goes to zero. It is clear that the sequence  $(\bar{v}_\varepsilon)_\varepsilon$  is nondecreasing and that  $\bar{v}_\varepsilon \leq v$  on  $[0, T] \times \bar{\mathcal{S}}$  for any  $\varepsilon > 0$ . Let us prove that  $\lim_{\varepsilon \searrow 0} \bar{v}_\varepsilon = v$ . Fix  $n \in \mathbb{N}^*$  and  $(t, z, \theta) \in [0, T] \times \bar{\mathcal{S}}$  and consider some  $\alpha^{(n)} \in \mathcal{A}_\ell^b(t, z, \theta)$  such that

$$\mathbb{E} \left[ U_L(Z_T^{(n)}, \Theta_T^{(n)}) \right] \geq v(t, z, \theta) - \frac{1}{n},$$

where  $(Z^{(n)}, \Theta^{(n)})$  is the associated controlled process. From the monotone convergence theorem, we then get

$$\lim_{\varepsilon \searrow 0} \bar{v}_\varepsilon(t, z, \theta) \geq \mathbb{E} \left[ U_L(Z_T^{(n)}, \Theta_T^{(n)}) \right] \geq v(t, z, \theta) - \frac{1}{n}.$$

Sending  $n$  to infinity, we conclude that  $\lim_\varepsilon \bar{v}_\varepsilon \geq v$ , which ends the proof since we already have  $\bar{v}_\varepsilon \leq v$ .

**Step 2.** The nonlocal impulse operator  $\bar{\mathcal{H}}^\varepsilon$  associated to (B.1) is given by

$$\bar{\mathcal{H}}_\varepsilon \varphi(t, z, \theta) = \mathcal{H} \varphi(t, z, \theta) - \varepsilon,$$

and we consider the corresponding dynamic programming equation:

$$\min \left[ -\frac{\partial w}{\partial t} - \frac{\partial w}{\partial \theta} - \mathcal{L}w, w - \bar{\mathcal{H}}_\varepsilon w \right] = 0, \quad \text{in } [0, T] \times \bar{\mathcal{S}}, \quad (\text{B.2})$$

$$\min [w - U_L, w - \bar{\mathcal{H}}_\varepsilon w] = 0, \quad \text{in } \{T\} \times \bar{\mathcal{S}}. \quad (\text{B.3})$$

One can show by routine arguments that  $\bar{v}_\varepsilon$  is a constrained viscosity solution to (B.2)-(B.3), and as in Section 5, the following comparison principle holds:

Suppose  $u \in \mathcal{G}_\gamma([0, T] \times \bar{\mathcal{S}})$  is a usc viscosity subsolution to (B.2)-(B.3) on  $[0, T] \times \bar{\mathcal{S}}$ , and  $w \in \mathcal{G}_\gamma([0, T] \times \bar{\mathcal{S}})$  is a lsc viscosity supersolution to (B.2)-(B.3) on  $[0, T] \times \bar{\mathcal{S}}$ , such that

$$u(t, z, \theta) \leq \liminf_{\substack{(t', z', \theta') \rightarrow (t, z, \theta) \\ (t', z', \theta') \in [0, T] \times \bar{\mathcal{S}}}} w(t', z', \theta'), \quad \forall (t, z, \theta) \in [0, T] \times D_0.$$

Then,

$$u \leq w \quad \text{on} \quad [0, T] \times \mathcal{S}. \quad (\text{B.4})$$

The proof follows the same lines of arguments as in the proof of Theorem 5.2 (the function  $\psi$  is still a strict viscosity supersolution to (B.2)-(B.3) on  $[0, T] \times \bar{\mathcal{S}}$ ), and so we omit it.

**Step 3.** Let  $V \in \mathcal{G}_\gamma([0, T] \times \bar{\mathcal{S}})$  be a viscosity solution in  $\mathcal{G}_\gamma([0, T] \times \bar{\mathcal{S}})$  to (4.2)-(4.3), satisfying the boundary condition (4.4). Since  $\mathcal{H} \geq \bar{\mathcal{H}}_\varepsilon$ , it is clear that  $V_*$  is a viscosity supersolution to (B.2)-(B.3). Moreover, since  $\lim_{(t', z', \theta') \rightarrow (t, z, \theta)} V_*(t', z', \theta') = U(0) = v(t, z, \theta) \geq \bar{v}_\varepsilon^*(t, z, \theta)$  for  $(t, z, \theta) \in [0, T] \times D_0$ , we deduce from the comparison principle (B.4) that  $V \geq V_* \geq \bar{v}_\varepsilon^* \geq \bar{v}_\varepsilon$  on  $[0, T] \times \mathcal{S}$ . By sending  $\varepsilon$  to 0, and from the convergence result in Step 1, we obtain:  $V \geq v$ , which proves the required result.

## References

- [1] Almgren R. and N. Chriss (2001): “Optimal execution of portfolio transactions”, *Journal of Risk*, **3**, 5-39.
- [2] Almgren R., Thum C., Hauptmann E. and H. Li (2005): “Equity market impact”, *Risk*, July 2005, 58-62.
- [3] Barles G. (1994): Solutions de viscosité des équations d’Hamilton-Jacobi, *Math. et Appli.*, Springer Verlag.
- [4] Bensoussan A. and J.L. Lions (1982): Impulse control and quasi-variational inequalities, Gauthiers-Villars.
- [5] Bank P. and D. Baum (2004): “Hedging and portfolio optimization in illiquid financial markets with a large trader”, *Mathematical Finance*, **14**, 1-18.
- [6] Bayraktar E. and M. Ludkovski (2009): “Optimal trade execution in illiquid markets”, to appear in *Mathematical Finance*.
- [7] Bertsimas D. and A. Lo (1998): “Optimal control of execution costs”, *Journal of Financial Markets*, **1**, 1-50.
- [8] Bouchard B. (2009): “A stochastic target formulation for optimal switching problems in finite horizon”, *Stochastics*, **81**, 171-197.
- [9] Cetin U., Jarrow R. and P. Protter (2004): “Liquidity risk and arbitrage pricing theory”, *Finance and Stochastics*, **8**, 311-341.
- [10] Cetin U., Soner M. and N. Touzi (2008): “Option hedging for small investors under liquidity costs”, to appear in *Finance and Stochastics*.
- [11] Crandall M., Ishii H. and P.L. Lions (1992): “User’s guide to viscosity solutions of second order partial differential equations”, *Bull. Amer. Math. Soc.*, **27**, 1-67.
- [12] Engle R. and R. Ferstenberg (2007): “Execution risk”, *Journal of Portfolio Management*, **33**, 34-44.
- [13] Fleming W. and M. Soner (1993): Controlled Markov processes and viscosity solutions, Springer Verlag, Series: Stochastic Modelling and Applied Probability.

- [14] Gilbarg D. and N. Trudinger (1977): Elliptic partial differential equations of second order, Springer Verlag, Berlin.
- [15] Guilbaud F., Mnif M. and H. Pham (2010): “Numerical methods for an optimal order execution problem”, forthcoming.
- [16] He H. and H. Mamaysky (2005): “Dynamic trading policies with price impact”, *Journal of Economic Dynamics and Control*, **29**, 891-930.
- [17] Ishii K. (1993): “Viscosity solutions of nonlinear second order elliptic PDEs associated with impulse control problems”, *Funkcial. Ekvac.*, **36**, 123-141.
- [18] Korn R. (1998): “Portfolio optimization with strictly positive transaction costs and impulse control”, *Finance and Stochastics*, **2**, 85-114.
- [19] Lillo F., Farmer J. and R. Mantagna (2003): “Master curve for price impact function”, *Nature*, **421**, 129-130.
- [20] Ly Vath V., Mnif M. and H. Pham (2007): “A model of optimal portfolio selection under liquidity risk and price impact”, *Finance and Stochastics*, **11**, 51-90.
- [21] Ma J., Song Q., Xu J. and J. Zhang (2009): “Impulse control problem and optimal portfolio selection with general transaction costs”, working paper USC.
- [22] Obizhaeva A. and J. Wang (2005): “Optimal trading strategy and supply/demand dynamics”, to appear in *Journal of Financial Markets*.
- [23] Oksendal B. and A. Sulem (2002): “Optimal consumption and portfolio with both fixed and proportional transaction costs”, *SIAM J. Cont. Optim.*, **40**, 1765-1790.
- [24] Oksendal B. and A. Sulem (2006): Applied stochastic control of jump diffusions, Universitext, Springer Verlag.
- [25] Pham H. (2009): Continuous-time stochastic control and optimization with financial applications, Springer Verlag, Series: Stochastic Modelling and Applied Probability.
- [26] Pham H. and P. Tankov (2008): “A model of optimal consumption under liquidity risk with random trading times”, *Mathematical Finance*, **18**, 613-627.
- [27] Potters M. and J.P. Bouchaud (2003): “More statistical properties of order books and price impact”, *Physica A*, **324**, 133-140.
- [28] Rogers L.C.G. and S. Singh (2008): “The cost of illiquidity and its effects on hedging”, to appear in *Mathematical Finance*.
- [29] Schied A. and T. Schöneborn (2009): “Risk aversion and the dynamics of optimal liquidation strategies in illiquid markets”, *Finance and Stochastics*, **13**, 181-204.
- [30] Seydel R. (2008): “Existence and uniqueness of viscosity solutions for QVI associated with impulse control of jump-diffusions”, Preprint, University of Leipzig.
- [31] Soner H. (1986): “Optimal control with state-space constraint”, *SIAM J. Control and Optimization*, **24**, 552-561.
- [32] Tang S. and J. Yong (1993): “Finite horizon stochastic optimal switching and impulse controls with a viscosity solution approach”, *Stoch. and Stoch. Reports*, **45**, 145-176.
- [33] Zariphopoulou T. (1988): Optimal investment-consumption models with constraints, PhD Thesis, Brown University.