

Optimal Power Flow using the Moth Flam Optimizer: A Case Study of the Algerian Power System

Bachir Bentouati*, Lakhdar Chaib, Saliha Chettih

LACoSERE Laboratory, Electrical Engineering Department, Amar Telidji University of Laghouat, Algeria
email : b.bentouati@lagh-univ.dz

Abstract

In this paper, a new technique of optimization known as Moth-Flam Optimizer (MFO) has been proposed to solve the problem of the Optimal Power Flow (OPF) in the interconnected power system, taking into account the set of equality and inequality constraints. The proposed algorithm has been presented to the Algerian power system network for a variety of objectives. The obtained results are compared with recently published algorithms such as; as the Artificial Bee Colony (ABC), and other meta-heuristics. Simulation results clearly reveal the effectiveness and the robustness of the proposed algorithm for solving the OPF problem.

Keywords: Moth flam optimizer, Optimal power flow, Power system optimization, Voltage profile

1. Introduction

Optimal power flow (OPF) is a well studied optimization problem in power systems. In 1962, such an issue was first introduced by Carpentier [2]. The problem of the OPF can be defined as a nonlinear programming problem [1]. The main objective of the OPF problem is to optimize chosen objective functions such as piecewise quadratic cost function, fuel cost with valve point effects and voltage profile improvement, by optimal adjusting the power system control variables and satisfying various system operating such as power flow equations and inequality constraints, simultaneously [3–6].

To solve this problem, the researchers proposed a number of optimization algorithms over the years. Therefore optimization is known as one of the most current problem facing research, a good optimization leads to an optimal solution for an efficient system. The first solution method for the OPF problem was proposed by Dommel and Tinney [7] in 1968, and since then numerous other methods have been proposed, some of them are: Ant Colony Optimization (ACO) [8], Genetic Algorithm (GA) [9-10], enhanced genetic algorithm (EGA) [11-12], Hybrid Genetic Algorithm (HGA) [13], artificial neural network (ANN) [14], Particle swarm optimization (PSO) [15], fuzzy based hybrid particle swarm optimization (fuzzy HPSO) [16], Tabu Search (TS) [17], Gravitational Search Algorithm (GSA) [18]. Biogeography based optimization algorithm (BBO) [19], harmony search algorithm (HS) [20], krill herd algorithm (KHA) [21], Cuckoo Search (CS) [22], adaptive group search optimization (AGSO) [23], Black-Hole-Based Optimization (BHBO) [24]. The reported results were promising and encouraging new research in this direction.

A new method known as the Moth-Flame Optimization MFO algorithm this method has been proposed by Seyedali Mirjalili [25] in 2015 is a nature-inspired method from navigating mechanism of moths in nature called transverse orientation, which has not received yet much attention in the power system. Hence, the first objective of this paper is to apply a new method that is the MFO in order to solve the OPF problem. In what follows, we will briefly give the mathematical model on the proposed algorithm of spiral flying path of moths around artificial lights (flames) [25].

In this paper, an approach based on MFO is proposed to solve the OPF problem. This problem has been formulated as a nonlinear optimization problem with equality and inequality constraints. Indeed, different objectives are considered in this work to minimize the cost of fuel, emission, and improve the voltage profile. Moreover, this method is simulated and tested on the Algerian power system network. In addition, the results are compared with other methods reported in any relevant literature dealing with the subject.

The organization of this paper is as follows: Section 2 discusses the problem formulation of OPF while brief description of MFO, It is followed by OPF implementation in solving OPF problem in Section 3. Section 4 presents the simulation results and discussion. Finally, Section 5 states the conclusion of this paper.

2. The Formulation of OPF Problem

In general, the mathematical formulation of OPF problem can be formulated as an optimization problem subject to nonlinear constraints:

$$F(x, u) \quad (1)$$

$$G(x, u) = 0 \quad (2)$$

$$H(x, u) \leq 0 \quad (3)$$

Equations (4) and (5) give respectively the vectors of control variables 'u' and state variables 'x' of the problem of OPF:

$$u = [P_g, V_g, T_c, Q_c] \quad (4)$$

where P_g : active power Generator output at PV buses except at the slack bus. V_g : voltages Generation bus T_{L_c} : Transformer taps settings. Q_c : Shunt VAR compensation.

$$x = [V_L, \theta, P_s, Q_s] \quad (5)$$

where V_L : voltage profile to load buses θ : Argument voltages of all the buses, except the beam node (slack bus) P_s : Active power generated to the balance bus (slack bus). Q_s : reactive powers generated of generators buses.

2.1. Equality Constraints

Ties constraints of the OPF reflect the physical system of electrical energy. They represent the flow equations of active and reactive power in an electric network, which are represented respectively by equations (6) and (7):

$$P_k = 0 = PG_k - PD_k = V_k \sum_{j=1}^N V_j [G_{kj} \cos(\delta_k - \delta_j) + B_{kj} \sin(\delta_k - \delta_j)] \quad (6)$$

$$Q_k = 0 = QG_k - QD_k = V_k \sum_{j=1}^N V_j [G_{kj} \sin(\delta_k - \delta_j) + B_{kj} \cos(\delta_k - \delta_j)] \quad (7)$$

G_{kj}, B_{kj} Elements of the admittance matrix (conductance and susceptance respectively).

2.2. Inequality Constraints

$$P_{i,\min}^g \leq P_i^g \leq P_{i,\max}^g \quad i=1 \dots n_g \quad (8)$$

$$Q_{i,\min}^g \leq Q_i^g \leq Q_{i,\max}^g \quad i=1 \dots n_g \quad (9)$$

$$V_{i,\min}^g \leq V_i^g \leq V_{i,\max}^g \quad i=1 \dots n_g \quad (10)$$

$$Q_{i,\min}^{sh} \leq Q_i^{sh} \leq Q_{i,\max}^{sh} \quad i=1 \dots n_{sh} \quad (11)$$

$$T_{i,\min}^g \leq T_i^g \leq T_{i,\max}^g \quad i=1 \dots n_T \quad (12)$$

where $P_{i,\min}^g$, $P_{i,\max}^g$, $Q_{i,\min}^g$, and $Q_{i,\max}^g$ are the maximum active power, minimum active power, maximum reactive power, and minimum reactive power of the i th generation unit, respectively. In addition, $V_{i,\min}^g$, $V_{i,\max}^g$ are the maximum and minimum limits of voltage amplitude, respectively. $Q_{i,\min}^{sh}$ stands for lower and $Q_{i,\max}^{sh}$ stands for upper limits of compensator capacitor. Finally, $T_{i,\min}^g$ and $T_{i,\max}^g$ presents lower and upper bounds of tap changer in i th transformer.

Security constraints: involve the constraints of voltages at load buses and transmission line loading as:

$$V_{i,\min}^L \leq V_i^L \leq V_{i,\max}^L \quad i=1,\dots,n_L \quad (13)$$

$$S_i^L \leq S_{i,\max}^L \quad i=1,\dots,n_l \quad (14)$$

where $V_{i,\max}^L$ and $V_{i,\min}^L$ are the minimum and maximum load voltage of i th unit, S_i^L defines apparent power flow of i th branch. $S_{i,\max}^L$ defines maximum apparent power flow limit of i th branch.

A penalty function [26] is added to the objective function, if the functional operating constraints violate any of the limits. The initial values of the penalty weights are considered as in [27].

3. Moth Flam Optimizer [19]

Moth Flam Optimizer (MFO) was first introduced in [25]. The MFO has proved its competitiveness with many other optimization algorithm, which is inspired from physical phenomena in nature. The main inspiration of the proposed algorithm is the navigating mechanism of moths in nature that is called transverse orientation. Figure 1 shows a conceptual model of transverse orientation. Moths are fancy insects that flight in the night using moonlight, that have a special navigation method in the night. Their movement is done by maintaining a fixed angle with respect to the moon, which allows them to fly in a straight light. This method is called transverse orientation. However, due to artificial light, the moths do not move straight but spiral. For that, this light is considered as a new goal for moths that have to be converged. The optimization algorithm of this move is called Moth-Flame Optimization (MFO). In what follows, we will present the mathematical model of the proposed algorithm of spiral flying path of moths around artificial lights (flames). The application includes the finding of the optimal values of control variables to minimize the objective function.

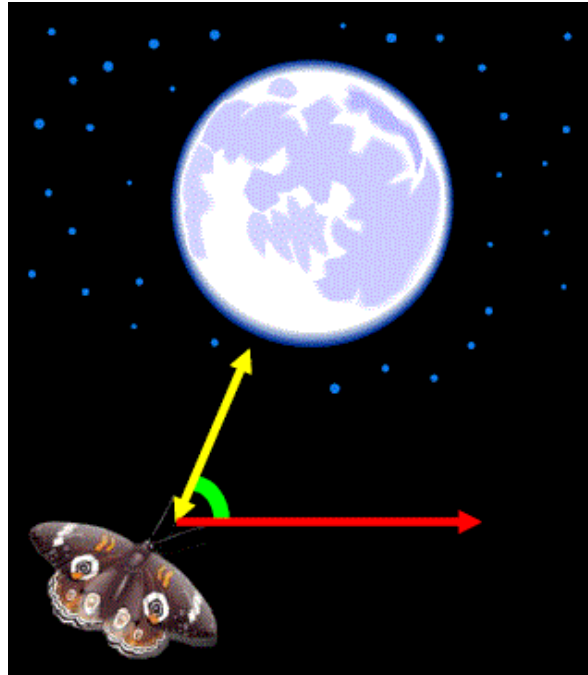

Figure 1. Transverse orientation [25]

3.1. Mathematical Modelling

It is assumed that the candidate solutions are the moths, and the variables of the problem are the position of moths in space. The moths can fly hyper dimensional space with changing their position vectors. MFO algorithm is based on the population. All the moths are represented in a matrix as follows:

$$M = \begin{bmatrix} m_{1,1} & \cdots & m_{1,d} \\ \vdots & \ddots & \vdots \\ m_{n,1} & \cdots & m_{n,d} \end{bmatrix} \quad (15)$$

Where n is the number of moths and d is the number of variables (dimension). We assume a table to store the values of all moths the formatting as follows:

$$OM = \begin{bmatrix} OM_1 \\ OM_2 \\ \vdots \\ OM_n \end{bmatrix} \quad (16)$$

Where n is the number of moths. Another key components in the proposed algorithm are flames. A matrix similar to the moth matrix is considered as follows:

$$F = \begin{bmatrix} F_{1,1} & \cdots & F_{1,d} \\ \vdots & \ddots & \vdots \\ F_{n,1} & \cdots & F_{n,d} \end{bmatrix} \quad (17)$$

where n is the number of moths, and d is the number of variables (dimension).

It is also supposed that there is an array for storing the corresponding shaping of values as follows:

$$OF = \begin{bmatrix} OF_1 \\ OF_2 \\ \vdots \\ OF_n \end{bmatrix} \tag{18}$$

where n is the number of moths. The moths are actual search agents that move on the search space, while the flames are the best position moths. The position of each moth is updated with respect to a flame using the following equation:

$$M_i = S(M_i, F_j) \tag{19}$$

where M_i indicates the i -th moth, F_j indicates the j -th flame, and S is the spiral function. Considering these points, a logarithmic spiral is defined for the MFO algorithm as follows:

$$S(M_i, F_j) = D_i \cdot e^{bt} \cdot \cos(2\pi t) + F_j \tag{20}$$

where D_i indicates the distance of the i -th moth for the j -th flame, b is a constant for defining the shape of the logarithmic spiral, and t are a random number in $[-1, 1]$. The logarithmic spiral, space around the flame, and the position considering different t on the curve are illustrated in Figure 2.

D is calculated as follows:

$$D_i = |F_j - M_i| \tag{21}$$

where D_i indicates the distance of the i -th moth for the j -th flame.

Number of flames is reduced by increasing the number of iterations. The following formula is utilized in this subject:

$$flam\ no = round(N - l * \frac{N - 1}{T}) \tag{22}$$

where l is the current number of iteration, N is the maximum number of flames, and T denote the maximum number of iterations.

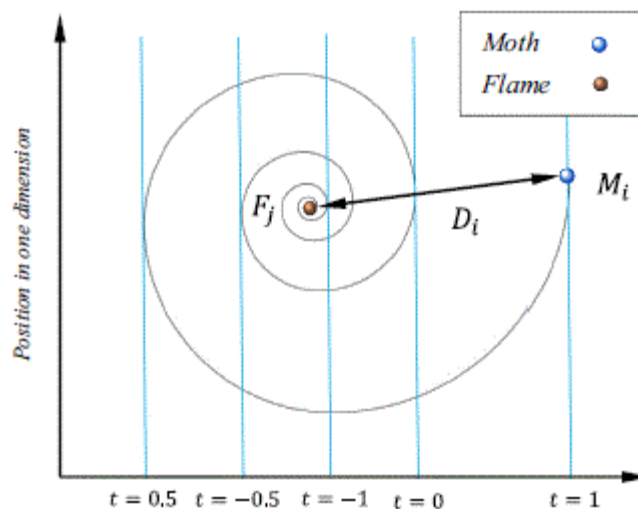

Figure 2. Logarithmic spiral, space around a flame, and the position with respect to t [25]

3.2. Implementation of the Proposed MFO Algorithm to the OPF Problem

The summarize flowchart of the proposed moth-flame algorithm is given in Figure 3.

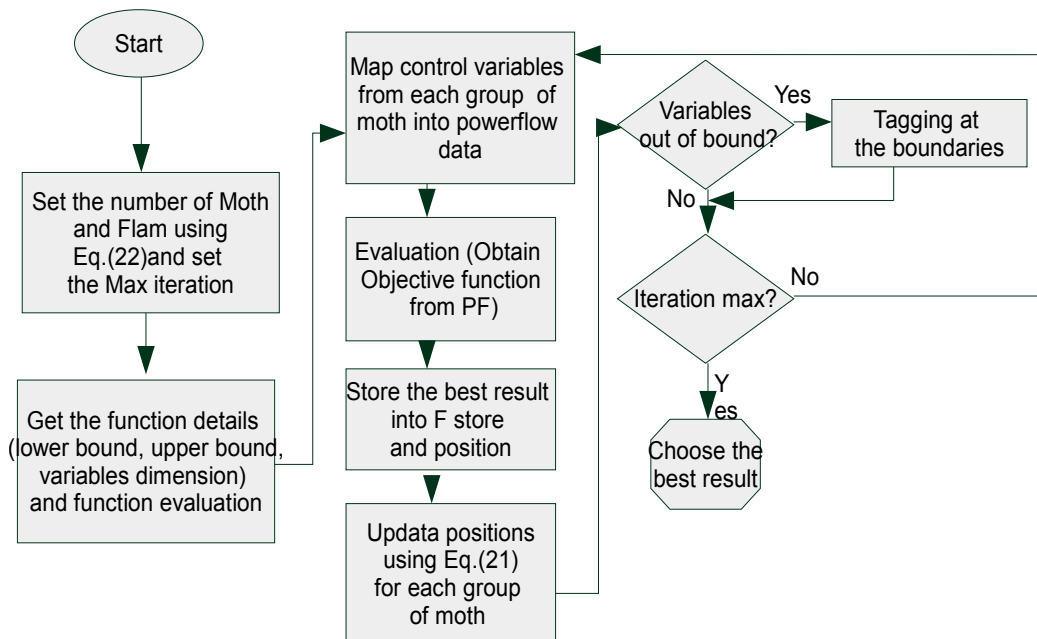

Figure 3. Flow of proposed MFO for solving OPF

where, the boundary limits and variable of control are given by;

$lb=[lb_1, lb_2, \dots, lb_n]$ is the lower bound of variable n ;

$ub=[ub_1, ub_2, \dots, ub_n]$ the upper bound of variable n .

Our objective is to solve the OPF problem. Hence, we will apply the moth-flame method for this purpose as follows;

The control variables are: P , V , T and Q_c

Where

$$Lb=[P_{min}, V_{min}, T_{min}, Q_{c min}] \quad (23)$$

$$Ub=[P_{max}, V_{max}, T_{max}, Q_{c max}] \quad (24)$$

4. Application and Results

In order to show the robustness and effectiveness of proposed MFO approach for solving OPF problem in larger power systems, it has been tested on Algerian 59-bus test system shown in Figure 4. Which has a 20 control variables. This network is composed 10 generator, 36 loads of 684.10MW and 83 branches, knowing that the generator of the bus No. 13 is not in service. The values of coefficients fuel costs and emissions of the ten generators, the various network control variables and their ranges considered throughout this study and other parameters are given in [28]. The parameter settings to execute MFO is: Number of population = 40, maximum of iteration = 150.

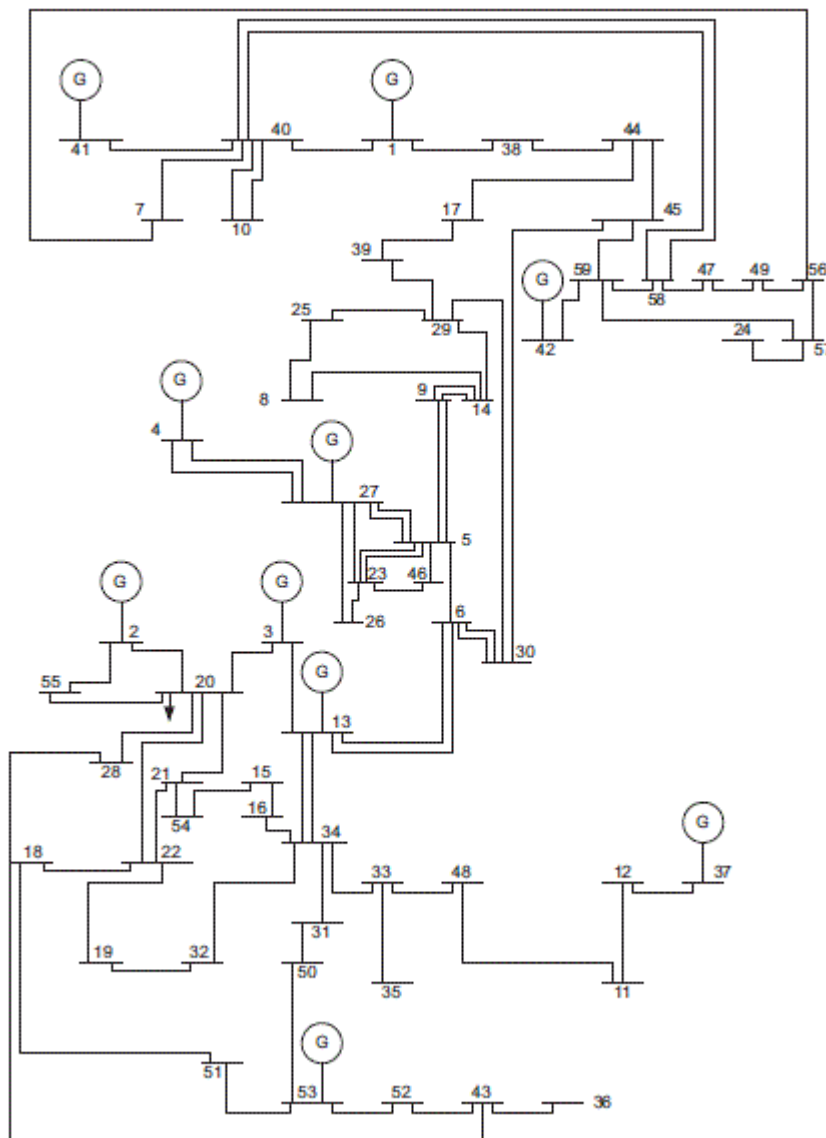

Figure 4. Single line diagram of the Algerian production and transmission network 59-bus system [24]

The MFO method has been applied to solve the OPF problem for the following cases:

Case 0: The basic case

Case 1: Minimization of generation fuel cost.

Case 2: Minimization of total emission.

Case 3: Voltage profile improvement.

Case 4: Voltage profile improvement with fuel cost minimization.

Case 5: Minimization of generation fuel cost and emission.

Case 6: Minimization of generation fuel cost with considering valve point effect.

The value of the voltage profile is constantly maintained within the allowable operating limits by adding the penalty factor. The proposed work was implemented and computed under Intel(R) Core(TM), 2.40 GHz computer with 8 GB RAM.

4.1. Case 1: Minimization of Generation Fuel Cost

In this case, we are interested in solving the problem of OPF while minimizing the corresponding fuel cost production. The nature and form of the objective function in this case is:

$$\text{Case 1} = \sum_{i=1}^{N_g} F_i(P_{gi}) = \sum_{i=1}^{N_g} (a_i + b_i P_{gi} + c_i P_{gi}^2) + \text{Penalty} \quad (23)$$

where N_g : Total number of generators. P_{gi} : active power generated by the unit i . a_i, b_i, c_i are the fuel cost coefficients of the i th generator

The reduction of the objective function can be achieved by finding the optimal set of control parameters which is a minimum production cost. The results of the optimal control variables obtained in this case are shown in Table 1. These values give us the best solution in production cost (minimum cost of fuel). Additionally, it can be seen that the optimal power flow problem led economic dispatch to control the active power while considering flexible functional constraints for influencing in the optimization procedure, it can be noted that all the control variables remained in their permissible limits. The values of fuel cost for the Algerian 59-bus test system are 1693,6193 (\$/hr), the MFO is considered as 12.8% less than the base case. The voltage diagram shown in Figure 5 illustrates that MFO violated the upper boundaries in a few buses.

Figure 6 shows the variation of the fuel cost based on the number of iterations for the proposed algorithms MFO. As observed, from and onwards 60 iterations there is no change in the fuel cost function value. That signifies the optimal solution for the problem can be obtained within 60 iterations. This can be justified by performance of the proposed method to explore the search space and minimize the rate of convergence. The MFO manages to find a good production cost with greater convergence rate which is measured by the number of generations.

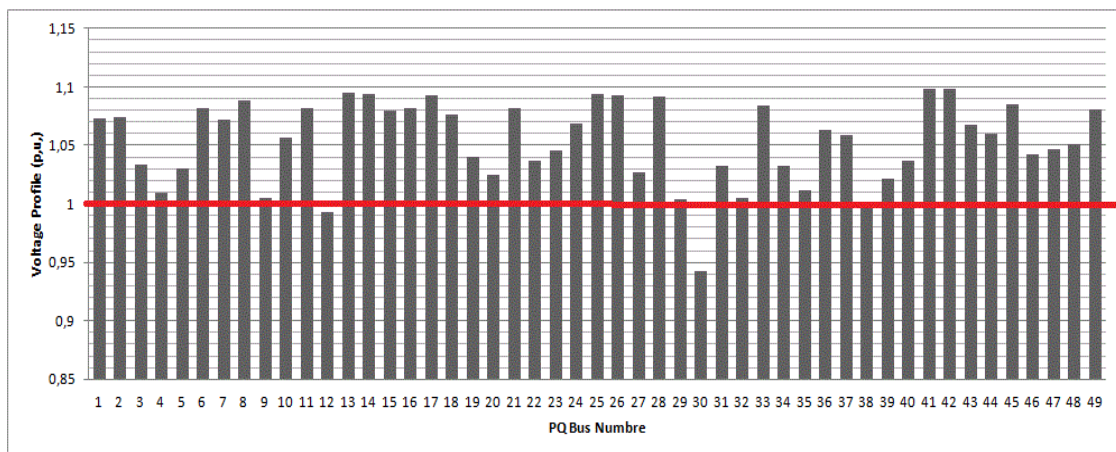

Figure 5. Voltage diagram for case 1

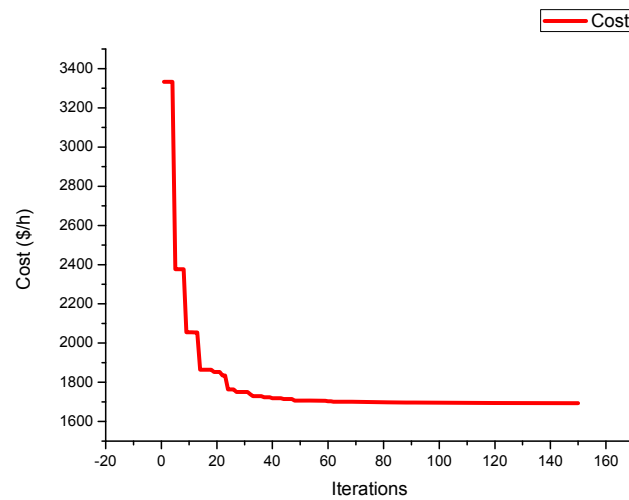

Figure 6. Convergence for case 1

Table 1. Optimal settings of control variables for different cases

Control variable	Case 0	Case 1	Case 2	Case 3	Case 4	Case 5	Case 6
V _{G1}	1,06	1,0999	1,1	1,099	1,1	1,1	0,96727
V _{G2}	1,04	1,0874	1,0975	1,0066	1,003	1,1	1,1
V _{G3}	1,05	1,098	1,098	0,9406	0,94	1,099	1,0872
V _{G4}	1,0283	1,0914	1,0896	1,0616	1,0392	1,0177	0,9976
V _{G5}	1	1,0994	1,0879	0,98048	1,0005	1,1	1,0264
V _{G6}	1,0266	1,0907	1,0895	1,04244	1,0393	1,018	1,0199
V _{G7}	1,0273	1,1	1,1	1,0308	1,03	1,1	1,093
V _{G8}	1,0966	1,09996	1,097051	1,0133	1,0207	1,097	1,0409
V _{G9}	1,034	1,1	1,097	1,0593	1,0684	1,0999	1,1
V _{G10}	1	1,09972	1,093	1,1	1,1	1,0986	1,06342
P _{G1}	8,0436	56,599	9,065	71,9711	72	28,38	60,8856
P _{G2}	70	23,5344	69,994	67,2696	24,164	64,2715	51,6744
P _{G3}	70	104,349	90,7919	31,0485	120,895	101,730	149,479
P _{G4}	115	114,893	86,4097	121,649	114,357	111,062	76,8308
P _{G5}	0	0	0	0	0	0	0
P _{G6}	40	10	82,402	64,062	33,4847	10	99,2313
P _{G7}	30	51,471	58,383	40,7262	49,676	58,8279	10
P _{G8}	110	98,5932	72,129	118,764	79,055	85,7488	140
P _{G9}	70	145,321	90,9795	174,595	146,424	103,18	42,4206
P _{G10}	200	105,779	87,646	188,862	113,792	103,649	50,0607
Fuel cost (\$/h)	1943,4	1693,61	1811,93	2165,57	1732,852	1739,18	1773,04
Emission (ton/h)	0,5834	0,5786	0,3844	1,8907	0,5922	0,4333	0,6488
Ploss (MW)	28,944	29,621	23,078	40,573	26,391	30,298	30,144
QPloss(MVar)	97,83	112,37	76,85	150,01	111,82	108,28	108,01
VD	1,48	2,77	2,79	1,335	1,435	2,508	2,0101

4.2. Case 2: Minimization of Total Emission

The central thermal power generations are a major source of greenhouse gases emission: nitrogen oxides (NO_x), sulfur dioxide (SO₂) and carbon dioxide (CO₂). The function of emissions includes two terms, a polynomial term and an exponential term. The analytical expression for this function is as follows:

$$Case\ 2 = \sum_{i=1}^{N_g} (\alpha_i + \beta_i P g_i + \gamma_i P g_i^2 + \mu_i exp(\xi_i P g_i)) + Penalty \tag{24}$$

with $\alpha_i, \beta_i, \gamma_i, \mu_i$ and ξ_i are the emission factors for unit i .

The optimal values of the control variables obtained by minimizing emissions through the algorithm are given in Table 1. From this result, it is clear that emissions are reduced to 0,3844 tons/hour, which reduces emissions over 34.5% compared to the base case. Figure 7 shows the variation of the emission depending on the number of iterations for the proposed method. The same remarks can be deducted as before.

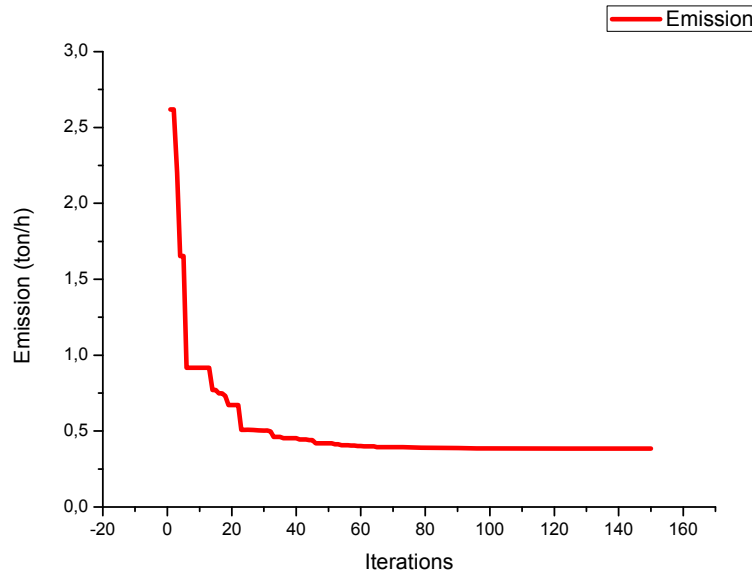

Figure 7. Convergence for case 2

4.3. Case 3: Voltage Profile Improvement

For improving the voltage profile, a target representing the reduction in the gap voltage load buses compared to the unit (1 pu) is included in the OPF, this can be written as follows:

$$Case\ 3 = \sum_{i=1}^{npq} |V_i - 1| + Penalty \quad (25)$$

where V_i voltage profil to load buses (pu), npq Total load buses.

We must also minimize the deviation of the voltage profile of all buses in the network. The optimum values of the 20 control variables obtained in this case are shown in Table 1. Noting that, the voltage profile of a few buses is forced to 1 pu Figure8 depicts the voltage diagram of the Algerian 59-bus test system.

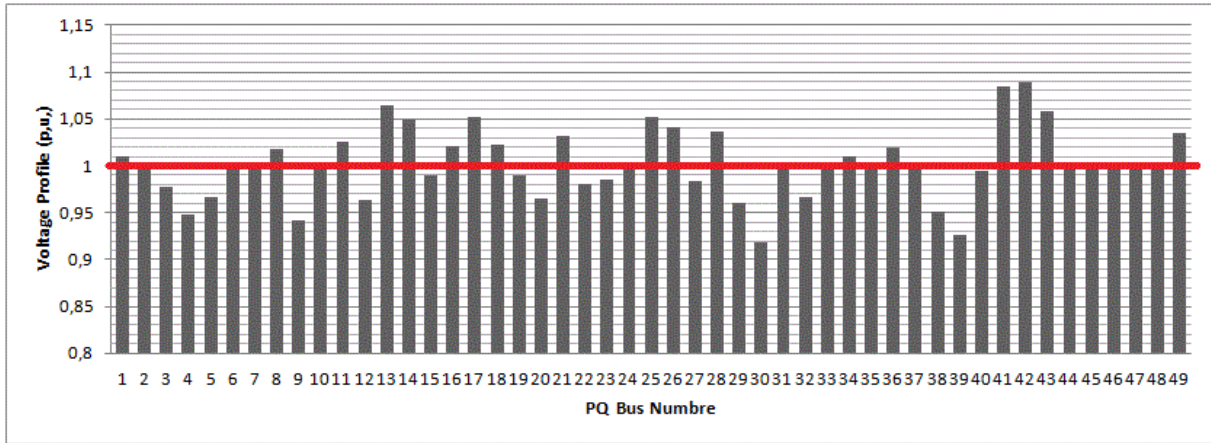

Figure 8. Voltage diagram for case 3

4.4. Case 4: Voltage Profile Improvement with Fuel Cost Minimization

In this case, two competing objectives, namely the voltage profile improvement and fuel cost are shown in the equation (26):

$$Case\ 4 = \sum_{i=1}^{N_g} (a_i + b_i P g_i + c_i P g_i^2) + \eta \sum_{i=1}^{npq} |V_i - 1| + Penalty \tag{26}$$

where: η is the weight factor, it was chosen carefully. After several experiments the weight coefficient related to the voltage profile and fuel cost is 500. We considered that the optimal solution is achieved with using the algorithm proposed and presented in the Table 1.

The total generation fuel cost and voltage deviations are 1732,852 \$/h and 1,435p.u for this case compared to Case 1 which gave us 1693,6193\$/h and 2,77 p.u. Note an increase in the fuel cost by 2.3 % but there is an improvement in the voltage profile by 48.4 %. The voltage diagram shown in Figure 9 illustrates in this case improvement compared with case 1, we can note from this figure that the voltage profile has improved and relieved

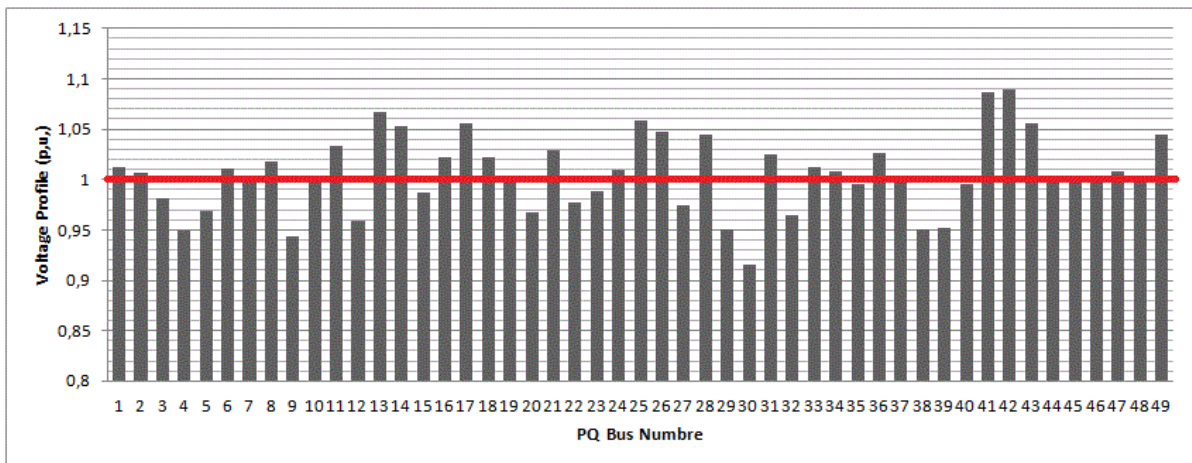

Figure 9. Voltage diagram for case 4

4.5. Case 5: Minimization of Generation Fuel Cost and Emission

In this simulation, the objective function is a combination of case 1 and case 2 which may be formulated as follows:

$$Case\ 5 = \sum_{i=1}^{N_g} (a_i + b_i P g_i + c_i P g_i^2) + \sum_{i=1}^{N_g} (\alpha_i + \beta_i P g_i + \gamma_i P g_i^2 + \mu_i \exp(\xi_i P g_i)) + Penalty \quad (27)$$

The optimal solution is obtained using the proposed MFO that is shown in the table (1). It is clear that the proposed method MFO provide well distributed solutions.

4.6. Case 6: Minimization of Generation Fuel Cost with Considering Valve Point Effect

For more rational and precise modelling of fuel cost function, the generating units with multi-valve steam turbines exhibit a greater variation in the fuel-cost functions [29]. The valve-point effects are taken into consideration in the problem by superimposing the basic quadratic fuel-cost characteristics with the rectified sinusoid component as follows:

$$Case\ 6 = \sum_{i=1}^{N_g} (a_i + b_i P g_i + c_i P g_i^2) + |d_i * \sin (e_i * (P_{g_i}^{min} - P g_i))| + Penalty \quad (28)$$

where: d_i and e_i are the coefficients that represent the valve-point loading effects, the coefficients are given in [28].

Clearly that MFO violated the upper boundaries in a generators buses as shown in Figure 10 and an amelioration in the reactive power.

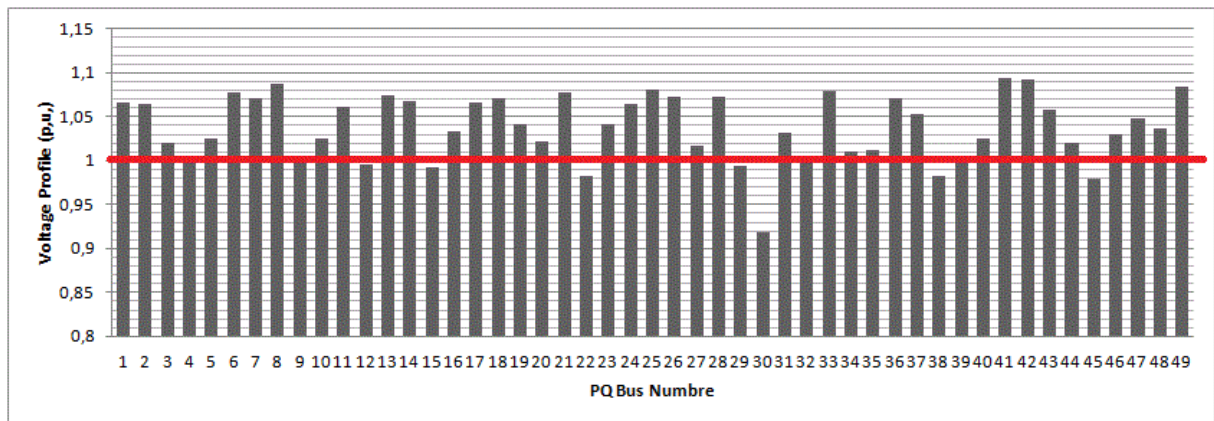

Figure 10. Voltage diagram for case 6

4.7 Comparative Study

The different cases in this paper are studied for the first time with the Algerian Power System. In table (2) a comparison between the results obtained by the proposed algorithms MFO with those found in the literature, which is made in this case for minimization of production cost. The results validate the proposed method and prove their performance in terms of solution quality.

Table 2. Some of results obtained by different algorithms

Method	Case 1	Case 2	Case 5		Method description
	Cost	Emission	Cost	Emission	
MFO	1693,6193	0,3844	1739,181	0,4333	Moth-Flam Optimizer
ABC [30]	1703.8	-	-	-	Artificial bee colony
FGA [13]	1768.5	-	-	-	Fuzzy Genetic Algorithm
PGA [31]	1769.7	0.4213	1765.7	0.4723	Decomposed Parallel GA
FSLP [32]	1775.856	0.4329	1786	0.4746	Fast successive linear programming
ACO [33]	1815.7	-	-	-	Ant Colony Optimization
GA [33]	1937.1	-	-	-	Genetic algorithm
BHBO[24]	1710.0859	-	-	-	Black-Hole-Based Optimization

Statistically: According to the all results obtained through the minimization of treated objectives, I wish to note that the process has run 50 times with different initial solutions for case 1, Table 3 indicates that algorithm offers the minimum values of best, worst, median values of fuel cost, and the average of the average total computational times. We can show that time of proposed MFO method is low, as well as note the difference between the minimum and the worst is very close, from it we can say that the proposed method is robust.

Table 3. Statistical results for case 1

Best	Median	Worst	Avr CPU time (s)
1693,6193	1694,2102	1694,546	25

To show the capability of proposed MFO approach in solving OPF problem in other power systems, The IEEE 30-bus with 41 branch systems has been tested in this party, which has a 25 control variables as follows: 6 generator voltage magnitudes, 4 transformer-tap settings, and 9 bus shunt reactive compensators. We are interested in solving the problem of OPF while minimizing the corresponding fuel production cost. The results of the optimal control variables obtained in this case are shown in Table (4). To verify whether the achieved result is better than the results of other algorithms or not, we have made a comparison with other known methods in the literature, which is offered in Table (5). This comparison shows the effectiveness and the robustness of the proposed algorithm, and we can say the MFO algorithm also provides very competitive results compared to other algorithms.

Table 4. Optimal settings of control variables

Control variable	Limits		MFO
	Min	Max	Fuel cost minimization
V_1 (p.u)	0.95	1.1	1,0999
V_2 (p.u)	0.95	1.1	1,0883
V_5 (p.u)	0.95	1.1	1,0986
V_8 (p.u)	0.95	1.1	1,0733
V_{11} (p.u)	0.95	1.1	1,1
V_{13} (p.u)	0.95	1.1	1,0998
P_{G1} (MW)	50	200	176.656
P_{G2} (MW)	20	80	48,8937
P_{G5} (MW)	15	50	21,398
P_{G8} (MW)	10	35	20,9752
P_{G11} (MW)	10	30	12,0419
P_{G13} (MW)	12	40	12
T_{6-9}	0.9	1.1	0,9502
T_{6-10}	0.9	1.1	0,956
T_{4-12}	0.9	1.1	0,95014
T_{28-27}	0.9	1.1	0,95
QC_{10} (Mvar)	0	5	4,9994
QC_{12} (Mvar)	0	5	4,1815
QC_{15} (Mvar)	0	5	4,9811
QC_{17} (Mvar)	0	5	5
QC_{20} (Mvar)	0	5	4,9982
QC_{21} (Mvar)	0	5	4,88
QC_{23} (Mvar)	0	5	4,999
QC_{24} (Mvar)	0	5	4,7598
QC_{29} (Mvar)	0	5	5
Cost (\$/h)			798.9448

Table 5. Comparison of results for minimization of fuel cost

Algorithm	Cost (\$/h)	Method description
MFO	798.9448	Moth-Flam Optimizer
AGSO[23]	801.75	Adaptive Group Search Optimization
EP [34]	802.63	Evolutionary Programming
TS [17]	802.3	Tabu search
PSO [35]	802.205	Particle swarm optimization
ABC[36]	800.6600	Artificial bee colony algorithm
DE [37]	799.2891	Differential evolution algorithm
GA[38]	805.94	Genetic algorithm
BBO[19]	799.1116	Biogeography-Based Optimization
IGA[26]	800.805	Improved Genetic Algorithms
ICA[39]	801.843	Imperialist Competitive Algorithm
EADHDE[40]	800.1579	Genetic Evolving Ant Direction HDE
SA[41]	799.45	Simulated Annealing
SGA (wo-VP)[42]	802.359	Hybrid genetic algorithm
GM[43]	804.853	Gradient Method

5. Conclusion

In this study, Moth Flam Optimizer has been presented and applied to solve the OPF problem. The program can treat different objectives in order to: minimize the total fuel cost, minimize the total emission and minimize, improve the voltage profile, the total fuel cost considering the valve point effect. Through the applications that made for the first time on the Algerian 59-bus test system. The results obtained from the MFO approach were compared with those reported in the recent literature. According to the results obtained, the effectiveness, robustness and performance of MFO achieve the best of all objectives.

References

- [1] Carpentier J. Contribution to the Economic Dispatch Problem. *Bulletin Society Francaise Electriciens*. 1962; 3(8): 431-447.
- [2] M Cain, R O'Neill, and A Castillo. History of Optimal Power Flow and Formulations. *Fed, Energy Regul, Comm.* ..., no. 2012; 1-36.
- [3] Niknam T, Jabbari M, Malekpour AR. A modified shuffle frog leaping algorithm for multi-objective optimal power flow. *Energy*. 2011; 36: 6420-32.
- [4] Sayah S, Zehar K. Modified differential evolution algorithm for optimal power flow with non-smooth cost functions. *Energy Convers Manage*. 2008; 49: 3036-42.
- [5] Ghasemi M, Ghavidel S, Rahmani S, Roosta A, Falah H. A novel hybrid algorithm of imperialist competitive algorithm and teaching learning algorithm for optimal power flow problem with non-smooth cost functions. *Eng Appl Artif Intell*. 2014; 29: 54-69.
- [6] Ghasemi M, Ghavidel S, Ghanbarian MM, Massrur HR, Gharibzadeh M. Application of imperialist competitive algorithm with its modified techniques for multi-objective optimal power flow problem: a comparative study. *Inform Sci*. 2014.
- [7] H Dommel and W Tinney. Optimal Power Flow Solutions. *IEEE Tran, Power Appar, Syst*. 1968; 87(10): 1866-1876.
- [8] J Soares. T Sousa. ZA Vale. H Morais. and P Faria. Ant colony search algorithm for the optimal power flow problem. *IEEE Power Energy Soc, Gen, Meet*. 2011; 1-8.
- [9] TS Chung and YZ Li. A hybrid GA approach for OPF with consideration of FACTS devices. *IEEE Power Engineering Review*. 2001; 47-50.
- [10] LJ Cai, I Erlich and G Stamtzis. Optimal choice and allocation of FACTS devices in deregulated electricity market using genetic algorithms. *IEEE*. 2004.
- [11] K Kalaiselvi, V Kumar, and K Chandrasekar. Enhanced Genetic Algorithm for Optimal Electric Power Flow using TCSC and TCPS. *Proc. World*. 2010; (II).
- [12] AG Bakirtzis. P Biskas, CE Zoumas, and V Petridis. Optimal power flow by enhanced genetic algorithm. *Power Syst, IEEE Trans*. 2002; 17(2): 229-236.
- [13] Slimani L, Bouktir T. Optimal Power Flow Solution of the Algerian Electrical Network using Differential Evolution Algorithm. *TELKOMNIKA Indonesian Journal of Electrical Engineering*. 2012; 10(2): 199-210.
- [14] Badrul H Chowdhury. Towards the concept of integrated security: optimal dispatch under static and dynamic security constraints. *Electric Power Syst, Research*. 1992; 25: 213-225.

- [15] M Saravanan, SM Slochanal, P Venkatesh, J Abraham. Application of particle swarm optimization technique for optimal location of FACTS devices considering cost of installation and system loadability. *Electric Power Syst, Research*. 2007; 77: 276-283.
- [16] Liang Ruey-Hsun, Tsai Sheng-Ren, Chen Yie-Tone, Tseng Wan-Tsun. Optimal power flow by a fuzzy based hybrid particle swarm optimization approach. *Electr Power Syst Res*. 2011; 81(7): 1466-74.
- [17] Abido MA. Optimal power flow using tabu search algorithm. *Electric Power Compon Syst*. 2002; 30: 469-83.
- [18] S Duman U Güvenç, Y Sönmez and N Yörükeren. Optimal power flow using gravitational search algorithm. *Energy Convers, Manag*. 2012; 59: 86-95.
- [19] A Bhattacharya and PChattopadhyay. Application of biogeography-based optimisation to solve different optimal power flow problems. *IET Gener, Transm, Distrib*. 2011; 5(1): 70.
- [20] N Sinsupan, U Leeton and T Kulworawanichpong. *Application of Harmony Search to Optimal Power Flow Problems*. 2010:219-222.
- [21] A Mukherjee and V Mukherjee. *Solution of optimal power flow using chaotic krill herd algorithm*. Chaos, Solitons & Fractals. 2015; 78: 10-21.
- [22] M Rama, Mohana Rao and AV Naresh Babu. Optimal Power Flow Using Cuckoo Optimization Algorithm. *IJAREEIE*. 2013: 4213-4218.
- [23] Daryani N, Hagh MT & Teimourzadeh, S. Adaptive group search optimization algorithm for multi-objective optimal power flow problem. *Appl. Soft Comput*. 2016; 38: 1012-1024.
- [24] Bouchekara HREH. Optimal power flow using black-hole-based optimization approach. *Appl. Soft Comput*. 2014; 24: 879-888.
- [25] S Mirjalili. Knowledge-Based Systems Moth-flame optimization algorithm: A novel nature-inspired heuristic paradigm. *Knowledge-Based Syst*. 2015.
- [26] L Lai, JT Ma, R Yokoyama, and M Zhao. Improved genetic algorithms for optimal power flow under both normal and contingent operation states. *Int, J, Electr, Power Energy Syst*. 1997; 19(5): 287-292.
- [27] O Alsac and B Stott. Optimal Load Flow with Steady-State Security. *IEEE Trans, Power Appar, Syst*. 1974; 93(3): 745-751.
- [28] HREH Bouchekara, MA Abido, AE Chaib, R Mehasni. Optimal power flow using the league championship algorithm: a case study of the Algerian power system. *Energy Convers. Manag*. 2014; 87: 58-70.
- [29] H Hardiansyah. A Modified Particle Swarm Optimization Technique for Economic Load Dispatch with Valve-Point Effect. *Int, J, Intell, Syst, Appl*. 2013; 5(7): 32-41.
- [30] Slimani L. Bouktir T. Economic power dispatch of power system with pollution control using artificial bee colony optimization. *Turkish J Electr Eng Comput Sci*. 2013; 21(06): 1515-27.
- [31] Mahdad B, Bouktir T, Srairi K. OPF with environmental constraints with SVC controller using decomposed parallel GA: application to the Algerian network. *J Electr Eng Technol, Korea*. 2009; 4(1): 55-65
- [32] Zehar K, Sayah S. Optimal power flow with environmental constraint using a fast successive linear programming algorithm: application to the Algerian power system. *Energy Convers Manage*. 2008; 49: 3362-6.
- [33] Bouktir T, Labdani R, Slimani L. Optimal power flow of the Algerian electrical network using ant colony optimization method. *Leonardo J Sci*. 2005: 43-57.
- [34] Ongsakul W, Tantimaporn T. Optimal power flow by improved evolutionary programming. *Electr Power Compon Syst*. 2006; 34(1): 79-95.
- [35] T Niknam, M Narimani J Aghaei and R Azizpanah-Abarghoee. Improved particle swarm optimisation for multi-objective optimal power flow considering the cost, loss, emission and voltage stability index. *IET Gener, Transm, Distrib*. 2012; 6(6): 515.
- [36] M Rezaei. Adaryani and A Karami. Artificial bee colony algorithm for solving multi-objective optimal power flow problem. *Int, J, Electr, Power Energy Syst*. 2013; 53: 219-230.
- [37] AA Abou El Ela, MA Abido and S R Spea. Optimal power flow using differential evolution algorithm. *Electr, Power Syst, Res*. 2010; 80(7): 878-885.
- [38] Paranjothi SR, Anburaja K. Optimal power flow using refined genetic algorithm. *Electr Power Compon Syst*. 2002; 30: 1055-63.
- [39] Ghanizadeh AJ, Mokhtari1 G, Abedi M, Gharehpetian GB. Optimal power flow based on imperialist competitive algorithm. *Int Rev Electr Eng*. 2011; 6(4).
- [40] Vaisakh K, Srinivas LR. Genetic evolving ant direction HDE for OPF with nonsmooth cost functions and statistical analysis. *Expert Syst Appl*. 2011; 38: 2046-62.
- [41] Roa-Sepulveda CA. Pavez-Lazo BJ. A solution to the optimal power flow using simulated annealing. *Int J Electr Power Energy Syst*. 2003; 25(1): 47-57.
- [42] Bhaskar MM, Maheswarapu S. A Hybrid Harmony Search Algorithm Approach for Optimal Power Flow. *TELKOMNIKA*. 2012; 9(2): 125-144.
- [43] Abido MA. Optimal power flow using particle swarm optimization. *Int J Electr Power Energy Syst*. 2002; 24(7): 563-71.