

Optimization of Distribution Network Configuration for Loss Reduction Using Artificial Bee Colony Algorithm

R. Srinivasa Rao, S.V.L. Narasimham, M. Ramalingaraju

Abstract—Network reconfiguration in distribution system is realized by changing the status of sectionalizing switches to reduce the power loss in the system. This paper presents a new method which applies an artificial bee colony algorithm (ABC) for determining the sectionalizing switch to be operated in order to solve the distribution system loss minimization problem. The ABC algorithm is a new population based metaheuristic approach inspired by intelligent foraging behavior of honeybee swarm. The advantage of ABC algorithm is that it does not require external parameters such as cross over rate and mutation rate as in case of genetic algorithm and differential evolution and it is hard to determine these parameters in prior. The other advantage is that the global search ability in the algorithm is implemented by introducing neighborhood source production mechanism which is a similar to mutation process. To demonstrate the validity of the proposed algorithm, computer simulations are carried out on 14, 33, and 119-bus systems and compared with different approaches available in the literature. The proposed method has outperformed the other methods in terms of the quality of solution and computational efficiency.

Keywords—Distribution system, Network reconfiguration, Loss reduction, Artificial Bee Colony Algorithm.

I. INTRODUCTION

THE distribution systems deliver power to the customers from a set of distribution substations and these are normally configured radially for effective co-ordination of their protective systems. There are two types of switches used in primary distribution systems; sectionalizing switches (normally closed) and tie switches (normally open). They are designed for both protection and configuration management in the system. Under normal operating conditions, feeders are frequently reconfigured by changing the open/closed state of each switch in order to reduce line losses or to avoid the overloading network branches. Since there are many candidate-switching combinations possible in a distribution system, finding the operating network reconfiguration becomes a complicated combinatorial, non-differentiable constrained optimization problem.

Distribution system reconfiguration for loss reduction was first proposed by Merlin *et al* [1]. They employed a blend of optimization and heuristics to determine the minimal-loss operating configuration for the distribution system represented by a spanning tree structure at a specific load condition. A branch and bound type heuristic algorithm was suggested by

Civanlar *et al*. [2], where a simple formula was developed for determination of change in power loss due to a branch exchange. In [3]–[5], the authors suggested to employ a power flow method-based heuristic algorithm (PFBHA) for determining the minimum loss configuration of radial distribution networks. In [6]–[8], the authors proposed a solution procedure employing simulated annealing (SA) to search an acceptable non-inferior solution. Nara *et al*. [9] presented an implementation using a genetic algorithm (GA) to look for the minimum loss configuration. Das [10] presents an algorithm based on the heuristic rules and fuzzy multi-objective approach for optimizing network configuration.

In this paper, a new algorithm called artificial bee colony (ABC) algorithm is proposed for the minimization of power losses in the distribution system. The artificial bee colony algorithm is a new metaheuristic approach, proposed by Karaboga [21]. It is inspired by the intelligent foraging behavior of honey bee swarm. The proposed method is tested on 14, 33 and 119 bus systems and results obtained are effective and encouraging.

The rest of this paper is organized as follows: Section II provides mathematical model of the problem; Section III describes overview of ABC algorithm; Section IV provides application of ABC to network reconfiguration problem; Section V provides results and section V outlines conclusions.

II. FORMULATION OF OPTIMIZATION MODEL FOR LOSS MINIMIZATION

The network reconfiguration problem in a distribution system is to find a best configuration of radial network that gives minimum power loss while satisfying certain operating constraints. The operating constraints are voltage profile of the system, current capacity of the feeder and radial structure of the distribution system. The objective function for the minimization of power loss is described as:

$$\text{Minimize } f = \min(P_{T, Loss}) \quad (1)$$

$$\text{Subjected to } V_{\min} \leq |V_i| \leq V_{\max} \quad (2)$$

$$|I_i| \leq |I_{i, \max}| \quad (3)$$

where

$P_{T, Loss}$ is the total real power loss of the system;

$|V_i|$ Voltage magnitude of bus i ;

V_{\min}, V_{\max} are bus minimum and maximum voltage limits respectively;

$I_i, I_{i,\max}$ are current magnitude and maximum current limit of branch i respectively;

A set of simplified feeder-line flow formulations is employed. Considering the single-line diagram depicted in Fig. 1, the recursive equations (4) to (6) are used to compute the power flow.

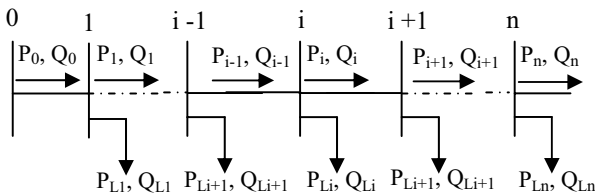

Fig. 1 Single-line diagram of a main feeder

Because of the complexity of the large scale distribution system, network reconfiguration problem is normally assumed as symmetrical system and constant loads. Therefore, the distribution lines are represented as series impedances of the value ($Z_{i,i+1} = R_{i,i+1} + jX_{i,i+1}$) and load demand as constant and balanced power sinks $S_L = P_L + jQ_L$. The real and reactive power flows at the receiving end of branch $i+1$, P_{i+1} , and Q_{i+1} , and the voltage magnitude at the receiving end, $|V_{i+1}|$ is expressed by the following set of recursive equations:

$$P_{i+1} = P_i - P_{Li+1} - R_{i,i+1} \cdot \frac{(P_i^2 + Q_i^2)}{|V_i|^2} \quad (4)$$

$$Q_{i+1} = Q_i - Q_{Li+1} - X_{i,i+1} \cdot \frac{(P_i^2 + Q_i^2)}{|V_i|^2} \quad (5)$$

$$|V_{i+1}|^2 = |V_i|^2 - 2(R_{i,i+1} \cdot P_i + X_{i,i+1} \cdot Q_i) + (R_{i,i+1}^2 + X_{i,i+1}^2) \cdot \frac{(P_i^2 + Q_i^2)}{|V_i|^2} \quad (6)$$

Equations (4) – (6) are known as the *Distflow equations*. Hence, if P_0, Q_0, V_0 at the first node of the network is known or estimated, then the same quantities at the other nodes can be calculated by applying the above branch equations successively. This procedure is referred to as a *forward update*.

Similar to forward update, a *backward update* is expressed by the following set of recursive equations [4]:

$$P_{i-1} = P_i + P_{Li} + R_{i,i+1} \cdot \frac{(P_i^2 + Q_i^2)}{|V_i|^2} \quad (7)$$

$$Q_{i-1} = Q_i + Q_{Li} + X_{i,i+1} \cdot \frac{(P_i^2 + Q_i^2)}{|V_i|^2} \quad (8)$$

$$|V_{i-1}|^2 = |V_i|^2 + 2(R_{i-1,i} \cdot P_i' + X_{i-1,i} \cdot Q_i') + (R_{i-1,i}^2 + X_{i-1,i}^2) \cdot \frac{(P_i'^2 + Q_i'^2)}{|V_i|^2} \quad (9)$$

where $P_i' = P_i + P_{Li}$ and $Q_i' = Q_i + Q_{Li}$

Note that by applying backward and forward update schemes successively one can get a power flow solution.

The power loss of the line section connecting between buses i and $i+1$ is computed as

$$P_{Loss}(i, i+1) = R_{i,i+1} \cdot \frac{(P_i^2 + Q_i^2)}{|V_i|^2} \quad (10)$$

The total power loss of the feeder $P_{F, Loss}$ is determined by summing up the losses of all line sections of the feeder, which is given by

$$P_{T, Loss} = \sum_{i=0}^{n-1} P_{Loss}(i, i+1) \quad (11)$$

where the total system power loss $P_{T, Loss}$ is the sum of power losses of all feeders in the system.

III. OVERVIEW OF ARTIFICIAL BEE COLONY ALGORITHM (ABC)

In the ABC algorithm, the colony of artificial bees contains three groups of bees: employed bees, onlookers and scouts. A bee waiting on the dance area for making decision to choose a food source is called an onlooker and a bee going to the food source visited by it previously is named an employed bee. A bee carrying out random search is called a scout. In the ABC algorithm, first half of the colony consists of employed artificial bees and the second half constitutes the onlookers. For every food source, there is only one employed bee. In other words, the number of employed bees is equal to the number of food sources around the hive. The employed bee whose food source is exhausted by the employed and onlooker bees becomes a scout. In the ABC algorithm, each cycle of the search consists of three steps: sending the employed bees onto the food sources and then measuring their nectar amounts; selecting of the food sources by the onlookers after sharing the information of employed bees and determining the nectar amount of the foods; determining the scout bees and then sending them onto possible food sources. At the initialization stage, a set of food source positions are randomly selected by the bees and their nectar amounts are determined. Then, these bees come into the hive and share the nectar information of the sources with the bees waiting on the dance area within the hive. At the second stage, after sharing the information, every employed bee goes to the food source area visited by her at the previous cycle since that food source exists in her memory, and then chooses a new food source by means of

visual information in the neighborhood of the present one. At the third stage, an onlooker prefers a food source area depending on the nectar information distributed by the employed bees on the dance area. As the nectar amount of a food source increases, the probability with which that food source is chosen by an onlooker increases, too. Hence, the dance of employed bees carrying higher nectar recruits the onlookers for the food source areas with higher nectar amount. After arriving at the selected area, she chooses a new food source in the neighborhood of the one in the memory depending on visual information. Visual information is based on the comparison of food source positions. When the nectar of a food source is abandoned by the bees, a new food source is randomly determined by a scout bee and replaced with the abandoned one. In our model, at each cycle at most one scout goes outside for searching a new food source and the number of employed and onlooker bees were equal.

The probability P_i of selecting a food source i is determined using the following expression:

$$P_i = \frac{fit_i}{\sum_{n=1}^{S_N} fit_n} \quad (12)$$

where fit_i is the fitness of the solution represented by the food source i and S_N is the total number of food sources. Clearly, with this scheme good food sources will get more onlookers than the bad ones. After all onlookers have selected their food sources, each of them determines a food source in the neighborhood of his chosen food source and computes its fitness. The best food source among all the neighboring food sources determined by the onlookers associated with a particular food source i and food source i itself, will be the new location of the food source i . If a solution represented by a particular food source does not improve for a predetermined number of iterations then that food source is abandoned by its associated employed bee and it becomes a scout, i.e., it will search for a new food source randomly. This tantamount to assigning a randomly generated food source (solution) to this scout and changing its status again from scout to employed. After the new location of each food source is determined, another iteration of ABC algorithm begins. The whole process is repeated again and again till the termination condition is satisfied.

The food source in the neighborhood of a particular food source is determined by altering the value of one randomly chosen solution parameter and keeping other parameters unchanged. This is done by adding to the current value of the chosen parameter the product of a uniform variate in $[-1, 1]$ and the difference in values of this parameter for this food source and some other solution randomly chosen food source. Formally, suppose each solution consists of d parameters and let $x_i = (x_{i1}, x_{i2}, \dots, x_{id})$ be a solution with parameter values $x_{i1}, x_{i2}, \dots, x_{id}$. In order to determine a solution v_i in the neighborhood of x_i , a solution parameter j and another solution $x_k = (x_{k1}, x_{k2}, \dots, x_{kd})$ are selected randomly. Except for the value of the selected parameter j , all other parameter values of v_i are same as x_i , i.e.,

$v_i = (x_{i1}, x_{i2}, \dots, x_{i(j-1)}, x_{ij}, x_{i(j+1)}, \dots, x_{id})$. The value v_i of the selected parameter j in v_i is determined using the following formula:

$$v_{ij} = x_{ij} + u(x_{ij} - x_{kj}) \quad (13)$$

where u is an uniform variate in $[-1, 1]$. If the resulting value falls outside the acceptable range for parameter j , it is set to the corresponding extreme value in that range.

IV. ABC ALGORITHM FOR NETWORK RECONFIGURATION PROBLEM

The proposed artificial bee colony algorithm is summarized as follows:

1. Read the line input data; Initialize MNC (Maximum Iteration Count) and base case as the best solution;
2. Construct initial Bee population (solution) x_{ij} as each bee is formed by the open switches in the configuration and the number of employed bees are equal to onlooker bees;
3. Evaluate fitness value for each employed bee by using the following the formula

$$fitness = \frac{1}{1 + Power Loss}$$

4. Initialize cycle=1;
5. Generate new population (solution) v_{ij} in the neighborhood of x_{ij} for employed bees using equation (13) and evaluate them;
6. Apply the greedy selection process between x_i and v_i ;
7. Calculate the probability values P_i for the solutions x_i by means of their fitness values using the equation (12);
8. Produce the new populations v_i for the onlookers from the populations x_i , selected depending on P_i by applying roulette wheel selection process, and evaluate them;
9. Apply the greedy selection process for the onlookers between x_i and v_i ;
10. Determine the abandoned solution, if exists, and replace it with a new randomly produced solution x_i for the scout bees using the following equation

$$x_{ij} = min_j + rand(0,1) * (max_j - min_j);$$
11. Memorize the best solution achieved so far;
12. cycle=cycle+1;
13. if cycle<MIC, go to step 5, otherwise go to step 14;
14. Stop.

The flow chart of the proposed method is shown in figure 2.

V. TEST RESULTS

The proposed method was tested on 14-bus [11], 33-bus [17], and 119-bus [18] radial distribution systems and results have been obtained to evaluate its effectiveness. For all these systems, the substation voltage is considered as 1.0 p.u. and all the tie and sectionalizing switches are considered as candidate switches for reconfiguration problem. The algorithm of this method was programmed in MATLAB

environment and run on a Pentium IV, 3-GHz personal computer with 0.99 GB RAM.

14-bus system: The first example is a three feeder, 14-bus radial distribution system [11], as shown in fig. 3. The input line and load data of the example system are shown in Table 1. The system consists of 13 sectionalizing switches (normally closed) and three tie switches (normally open). The solid line in fig. 3 represents the sectionalizing switches and a dotted line represents the tie switches. The tie lines of the system are 15, 21 and 26.

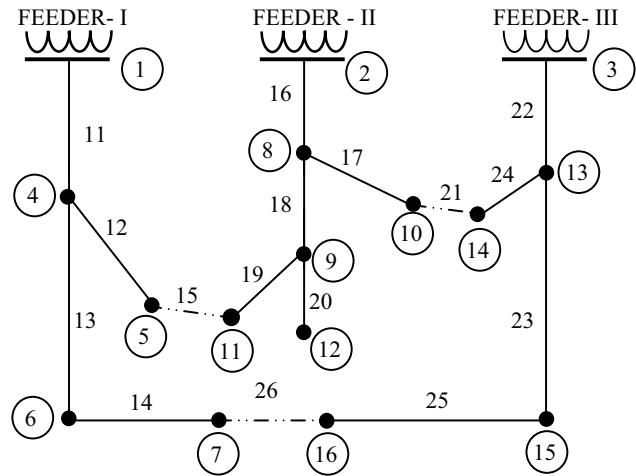

Fig. 3 Three- feeder, 14 bus distribution system

TABLE I INPUT DATA FOR 14-BUS SYSTEM

Bus to bus	Section Resistance (p.u)	Section Reactance (p.u)	End bus real Load (MW)	End bus reactive Load (MVar)	End bus fixed capacitor (MVar)
1-4	0.075	0.10	2.0	1.6	1.1
4-5	0.08	0.11	3.0	1.5	1.2
4-6	0.09	0.18	2.0	0.8	
6-7	0.04	0.04	1.5	0.2	
2-8	0.11	0.11	4.0	2.7	
8-9	0.08	0.11	5.0	3.0	1.2
8-10	0.11	0.11	1.0	0.9	
9-11	0.11	0.11	0.6	0.1	0.6
9-12	0.08	0.11	4.5	2.0	3.7
3-13	0.11	0.11	1.0	0.9	
13-14	0.09	0.12	1.0	0.7	1.8
13-15	0.08	0.11	1.0	0.9	
15-16	0.04	0.04	2.1	1.0	1.8
5-11	0.04	0.04			
10-14	0.04	0.04			
7-16	0.12	0.12			

The total active and reactive power loads on the system are 28.7 MW and 16.3 MVar. The system load is assumed to be constant and base MVA and voltage ratings of the system are selected as 100 MVA and 11 kV. The initial power loss obtained for the original configuration shown in fig. 3 is 511.4 kW. The minimum voltage in the system before reconfiguration is 0.9693 p.u which occur at node 9.

For this test case, the bee colony population size is taken as 30 and the number of employed bees is equal to onlooker bees. The scout bee is taken as 1. For this example maximum iteration count (MNC) is taken as 20. Simulations are carried from 5 to 20 iterations and all are converged to same solution after 5 iterations. The convergence characteristic is shown in fig. 4. The optimal power loss after reconfiguration is obtained as 466.1 kW. The minimum voltage at node 9 is improved to 0.9731 p.u. The results of the proposed algorithm are compared with the algorithms of Simulated Annealing [6] and Differential Evolution [11] and shown in Table 2.

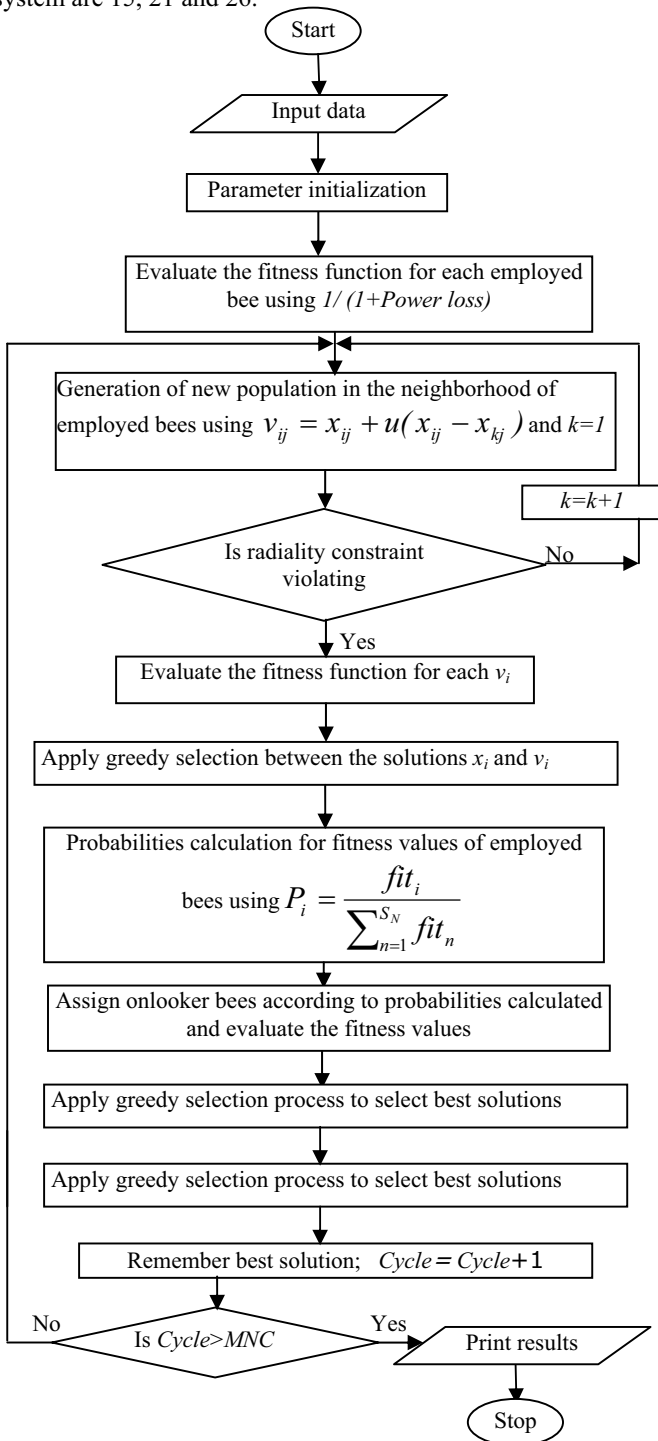

Fig. 2 Flowchart of the proposed algorithm

TABLE II SIMULATION RESULTS OF 14-BUS SYSTEM

Item	Tie switches	Power loss (kW)	Min. Node voltage (pu)	Power loss reduction (%)	CPU Time (sec)
Original Configuration	15, 21, 26	511.4	0.9693 (Node 9)	--	---
Proposed Method	19, 17, 26	464.1	0.9731 (Node 9)	8.15	4.3
SA [6]	19, 17, 26	466.1	0.9716	8.86	8.3
DE [11]	19, 17, 26	466.1	0.9716	8.86	7.7

From the Table 2, it is observed that the optimal power loss obtained by the proposed method is less than the other two methods SA[6] and DE [11]. The CPU time used to reach the optimal solution by the proposed method is approximately half the value in comparison to other methods.

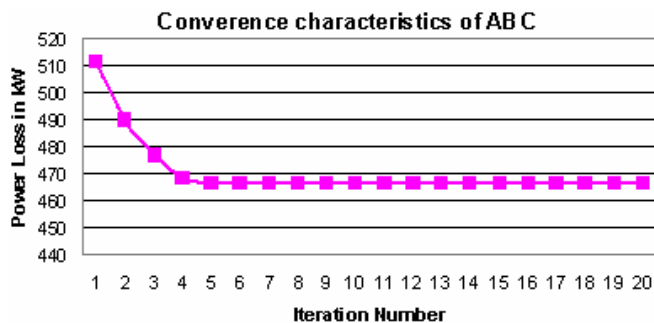

Fig. 4 Convergence characteristics of ABC for 14 bus radial distribution system

33- bus system: The second test system is a 33-bus, 12.66 kV, radial distribution system [17] shown in fig. 5. It consists of five tie lines and 32 sectionalize switches. The normally open switches are 33, 34, 35, 36 and 37 and the normally closed switches are 1 to 32. The data of the buses and lines are given Table 3. The total real and reactive power loads on the system are 3715 kW and 2300 kVAr. The initial power loss this system is 202.71 kW. The lowest bus bar voltage limit is 0.9131 p.u which occurs at node 18.

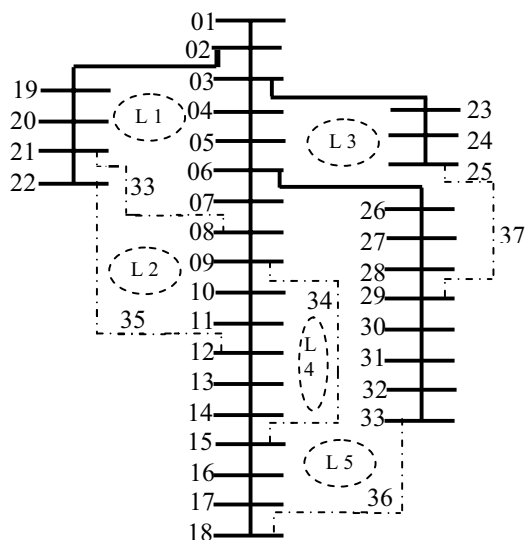

Fig. 5 33-Bus radial distribution system with loops

TABLEIV TEST DATA FOR 33-BUS SYSTEM

Line No.	From Bus	To Bus	R (Ω)	X (Ω)	Load at Receiving End Bus	
					Real Power Load (kW)	Reactive Power Load (kVAR)
1	1	2	0.0922	0.0477	100.0	60.0
2	2	3	0.4930	0.2511	90.0	40.0
3	3	4	0.3660	0.1840	120.0	80.0
4	4	5	0.3811	0.1941	60.0	30.0
5	5	6	0.8190	0.070	60.0	20.0
6	6	7	0.1872	0.6188	200.0	100.0
7	7	8	1.7114	1.2351	200.0	100.0
8	8	9	1.0300	0.7400	60.0	20.0
9	9	10	1.0400	0.7400	60.0	20.0
10	10	11	0.1966	0.0650	45.0	30.0
11	11	12	0.3744	0.1238	60.0	35.0
12	12	13	1.4680	1.1550	60.0	35.0
13	13	14	0.5416	0.7129	120.0	80.0
14	14	15	0.5910	0.5260	60.0	10.0
15	15	16	0.7463	0.5450	60.0	20.0
16	16	17	1.2890	1.7210	60.0	20.0
17	17	18	0.7320	0.5740	90.0	40.0
18	2	19	0.1640	0.1565	90.0	40.0
19	19	20	1.5042	1.3554	90.0	40.0
20	20	21	0.4095	0.4784	90.0	40.0
21	21	22	0.7089	0.9373	90.0	40.0
22	3	23	0.4512	0.3083	90.0	50.0
23	23	24	0.8980	0.7091	420.0	200.0
24	24	25	0.8960	0.7011	420.0	200.0
25	6	26	0.2030	0.1034	60.0	25.0
26	26	27	0.2842	0.1447	60.0	25.0
27	27	28	1.0590	0.9337	60.0	20.0
28	28	29	0.8042	0.7006	20.0	70.0
29	29	30	0.5075	0.2585	200.0	600.0
30	30	31	0.9744	0.9630	150.0	70.0
31	31	32	0.3105	0.3619	210.0	100.0
32	32	33	0.3410	0.5302	60.0	40.0
33*	21	8	2.0000	2.0000		
34*	9	15	2.0000	2.0000		
35*	12	22	2.0000	2.0000		
36*	18	33	0.5000	0.5000		
37*	25	19	0.5000	0.5000		

* Tie Lines, Substation Voltage=12.66 kV

For this test case, the bee colony population size is taken as 50 and the number of employed bees is and onlooker bees. The scout bee is taken as 1. The maximum iteration count (MNC) is taken as 100. Simulations are carried from 10 to 100 iterations and all are converged to same solution after 8 iterations. The CPU time used to get optimal solution is 5.3 seconds. The optimal configuration obtained by the proposed algorithm is 33,14,8, 32, 28, which has a real power loss of 139.5 kW. This amounts to a reduction of 31.2 % in total power loss. The minimum node voltage of the system after reconfiguration improved to 0.9437 p.u (node 33). The results of the proposed algorithm are compared with Genetic Algorithms [14] and Refined Genetic Algorithms [16] and are

presented in Table 2. From the results, it is observed that the optimal power loss obtained by the proposed method is 1.1 kW less than GA [14] and is same as RGA [16]. The CPU time used by the proposed method is 5.3 sec only but it is 15.2 and 13.8 in case of GA and RGA methods.

TABLE IV SIMULATION RESULTS OF 33-BUS SYSTEM

Item	Tie switches	Power loss (kW)	Min. Node voltage (pu)	Power loss reduction (%)	CPU Time (s)
Original Configuration	33,34,35, 36,37	202.71	0.9131 (Node 18)	--	--
Proposed Method	33,14,8, 32, 28	139.5	0.9437 (Node 33)	31.2	5.3
GA[14]	33,9,34, 28, 36	140.6	0.9371 (Node 33)	30.6	15.2
RGA[16]	7,9,14, 32, 37	139.5	0.9371 (Node 33)	31.2	13.8

The 119-Bus System: The third test system is a 119-bus, 11-kV distribution system [18] consists of 118 sectionalizing switches and 15 tie switches. The line and load data of the system is found in the reference [18]. The normally open switches are 119, 120, 121, 122, 123, 124, 125, 126, 127, 128, 129, 130, 131, 132 and 133. For this case, the initial real power loss is 1298.09 kW. Table 5, shows the results of the proposed method.

TABLE V SIMULATION RESULTS OF 119-BUS SYSTEM

Item	Tie switches	Power loss (kW)	Min. Node voltage (pu)	Power loss reduction (%)	CPU Time (s)
Original Configuration	119,120,121,122, 23,124,125,126, 127,128,129,130, 131,132,133	1294.3	0.9131	--	--
Proposed Method	43, 27, 24, 52, 123, 59, 40, 96, 75, 72, 98, 130, 131, 110, 35	865.87	0.9323 (Node 116)	33.1	9.1
TS [18]	43, 27, 23, 52, 49, 62, 40, 126, 74, 72, 77, 83, 131, 110, 33	884.16	0.9321 (Node 116)	31.7	20.5

For this test case, the bee colony population size is taken as 300 and the number of employed bees is equal to onlooker bees. The scout bee is taken as 1. The maximum iteration count (MNC) is taken as 500. The optimal configuration obtained with proposed algorithm is 43, 27, 24, 52, 123, 59, 40, 96, 75, 72, 98, 130, 131, 110, and 35. The power loss after reconfiguration is 865.87 kW. The percentage reduction in real power loss after reconfiguration is approximately 33% and the minimum node voltage of the are improved from 0.9131 p.u to 0.9323 (at node 116). The results of the proposed method are compared with the results of Tabu Search [18] and are shown in Table 5. It is observed that the power loss obtained by the proposed method is 2.6 kW less than the TS [18]. The CPU time used by the proposed

algorithm is 9.2 sec whereas it is 20.5 sec in case of simulated annealing method.

VI. CONCLUSIONS

In the present work, a new population based artificial bee colony algorithm (ABC) has been proposed to solve the network reconfiguration problem in a radial distribution system. The main objectives considered in the present problem are minimization of real power loss, voltage profile improvement and feeder load balancing subject to the radial network structure in which all loads must be energized. Simulations are carried on 14, 33 and 119 bus systems and results are compared with the other populations based methods such as GA, DE and simulated annealing. The results obtained by the proposed method out perform the other methods in terms of quality of the solution and computation efficiency.

The main advantage of ABC algorithm is that it does not require external parameters such as cross over rate and mutation rate etc, as in case of genetic algorithms, differential evolution and other evolutionary algorithms and these are hard to determine in prior. The other advantage is that the global search ability in the algorithm is implemented by introducing neighborhood source production mechanism which is a similar to mutation process.

As far as the authors knowledge this is the first application of artificial bee colony algorithm to network reconfiguration problem in distribution system. This paper demonstrates the capability of artificial bee colony algorithm in solving network reconfiguration problem. Ideas presented in this paper can be applied to many other power system problems also.

REFERENCES

- [1] A. Merlin, H. Back, "Search for a minimal-loss operating spanning tree configuration in an urban power distribution system" Proceedings of 5th Power System Computation Conference (PSCC), Cambridge, UK, 1975, pp. 1-18.
- [2] S. Civanlar, J. Grainger, H. Yin, and S. Lee, "Distribution feeder reconfiguration for loss reduction," *IEEE Trans. Power Del.*, vol. 3, no. 3, pp. 1217-1223, Jul. 1988.
- [3] D. Shirmohammadi and H.W. Hong, Reconfiguration of electric distribution networks for resistive line losses reduction," *IEEE Trans. Power Del.*, vol. 4, no. 2, pp. 1492-1498, Apr. 1989.
- [4] T. P. Wagner, A. Y. Chikhani, and R. Hackam, "Feeder reconfiguration for loss reduction: an application of distribution automation," *IEEE Trans. Power Del.*, vol. 6, no. 4, pp. 1922-1931, Oct. 1991.
- [5] S. Goswami and S. Basu, "A new for the reconfiguration of distribution feeders for loss minimization," *IEEE Trans. Power Del.*, vol. 7, no. 3, pp. 1484-1491, Jul. 1992.
- [6] H. C. Cheng and C. C. Kou, "Network reconfiguration in distribution systems using simulated annealing," *Elect. Power Syst. Res.*, vol. 29, pp. 227-238, May 1994.
- [7] H. D. Chiang and J. J. Rene, "Optimal network reconfiguration in distribution systems: part 1: a new formulation and a solution methodology," *IEEE Trans. Power Del.*, vol. 5, no. 4, pp. 1902-1908, Oct. 1990.
- [8] H. D. Chiang and J. J. Rene, "Optimal network reconfiguration in distribution systems: part 2: solution algorithms and numerical results," *IEEE Trans. Power Del.*, vol. 5, no. 3, pp. 1568-1574, Jul. 1992.
- [9] K. Nara, A. Shiose, M. Kitagawoa, and T. Ishihara, "Implementation of genetic algorithm for distribution systems loss minimum

- reconfiguration," *IEEE Trans. Power Syst.*, vol. 7, no. 3, pp. 1044–1051, Aug. 1992.
- [10] D. Das, "A fuzzy multi-objective approach for network reconfiguration of distribution systems," *IEEE Trans. Power Del.*, vol. 21, no. 1, pp. 202–209, Jan. 2006.
- [11] C. T. Su and C. S. Lee, "Network reconfiguration of distribution systems using improved mixed-integer hybrid differential evolution," *IEEE Trans. on Power Delivery*, Vol. 18, No. 3, July 2003.
- [12] Y. C. Huang, "Enhanced genetic algorithm-based fuzzy multi-objective approach to distribution network reconfiguration," *Proc. Inst. Elect. Eng.*, vol. 149, no. 5, pp. 615–620, 2002.
- [13] I. Z. Zhu, "Optimal reconfiguration of electrical distribution network using the refined genetic algorithm," *Elect. Power Syst. Res.*, vol. 62, pp. 37–42, 2002.
- [14] Y. Y. Hong and S. Y. Ho, "Determination of network configuration considering multi-objective in distribution systems using genetic algorithms," *IEEE Trans. Power Syst.*, vol. 20, no. 2, pp. 1062–1069, May 2005.
- [15] K. Prasad, R. Ranjan, N. C. Sahoo, and A. Chaturvedi, "Optimal reconfiguration of radial distribution systems using a fuzzy mutated genetic algorithm," *IEEE Trans. Power Del.*, vol. 20, no. 2, pp. 1211–1213, Apr. 2005.
- [16] J. Z. Zhu, "Optimal reconfiguration of electrical distribution network using the refined genetic algorithm," *Elect. Power Syst. Res.*, vol. 62, no. 1, pp. 37–42, May 2002.
- [17] M. E. Baran and F. Wu, "Network reconfiguration in distribution system for loss reduction and load balancing," *IEEE Trans. Power Del.*, vol. 4, no. 2, pp. 1401–1407, Apr. 1989.
- [18] Y. Mishima, K. Nara, T. Satoh, T. Ito, "Method for minimum-loss reconfiguration of distribution system by tabu search", *Electrical Engg. Japan*, Vol. 152, No. 2, July 2005.
- [19] D. Zhang, Z. Fu, L. Zhang, "An improved TS algorithm for loss-minimum reconfiguration in large-scale distribution systems", *Electric Power Systems Research*, Vol. 77, pp. 685–694, 2007.
- [20] Chun Wang and Hao Zhong Cheng, "Optimization of Network Configuration in Large Distribution Systems Using Plant Growth Simulation Algorithm," *IEEE Transactions on Power Systems*, VOL. 23, NO. 1, February 2008.
- [21] D. Karaboga, "An idea based on honey bee swarm for numerical optimization," Technical Report TR06, Computer Engineering Department, Erciyes University, Turkey, 2005.
- [22] B. Basturk, D. Karaboga, "An artificial bee colony (ABC) algorithm for numeric function optimization," *IEEE Swarm Intelligence Symposium 2006*, May 12–14, Indianapolis, IN, USA, 2006.
- [23] D. Karaboga, B. Basturk, "A powerful and efficient algorithm for numerical function optimization: artificial bee colony (ABC) algorithm", *Journal of Global Optimization*, Vol. 39, pp. 459–471, 2007.
- [24] D. Karaboga, B. Basturk, "On the performance of artificial bee colony (ABC) algorithm", *Applied Soft Computing* Vol. 8 pp. 687–697, 2008.

R. Srinivasa Rao is a research scholar in Jawaharlal Nehru Technological University, Hyderabad, INDIA. His areas of interest include electric power distribution systems and power systems operation and control.

S.V.L Narasimham is Professor of Computer Science and Engineering Department, Jawaharlal Nehru Technological University, Hyderabad, INDIA. His areas of interests include real time power system operation and control, ANN, Fuzzy logic and Genetic Algorithm applications to Power Systems.

M. Ramalingaraju is Professor of Electrical Engineering Department, Jawaharlal Nehru Technological University, Kakinada, INDIA. His areas of interests include Energy management, Energy conversion, ANN, Fuzzy logic and Genetic Algorithm applications to Power Systems.