



Optimization of PV/Wind/Micro-Hydro/Diesel Hybrid Power System in HOMER for the Study Area

Deepak Kumar Lal¹, Bibhuti Bhusan Dash², and A. K. Akella³

¹Department of Electrical Engineering VSS University of Technology, Odisha, Sambalpur-768018, INDIA

²Department of Physics, Silicon Institute of Technology, Sambalpur-768200, INDIA

³Department of Electrical Engineering, National Institute of Technology, Jamshedpur-831014, INDIA

Abstract: A large proportion of the world's population lives in remote rural areas that are geographically isolated and sparsely populated. This paper proposed a hybrid power generation system suitable for remote area application. The concept of hybridizing renewable energy sources is that the base load is to be covered by largest and firmly available renewable source(s) and other intermittent source(s) should augment the base load to cover the peak load of an isolated mini electric grid system. The study is based on modeling, simulation and optimization of renewable energy system in rural area in Sundargarh district of Orissa state, India. The model has designed to provide an optimal system configuration based on hour-by-hour data for energy availability and demands. Various renewable/alternative energy sources, energy storage and their applicability in terms of cost and performance are discussed. The homer software is used to study and design the proposed hybrid alternative energy power system model. The Sensitivity analysis was carried out using Homer program. Based on simulation results, it has been found that renewable/alternative energy sources will replace the conventional energy sources and would be a feasible solution for distribution of electric power for stand alone applications at remote and distant locations.

Index Terms: HOMER, hybrid energy system, Micro-hydropower, optimal system, Photovoltaic energy, renewable energy

1. Introduction

The world is ceased with four major priorities as per the U.N. these are 'Energy security', 'Drinking water', 'Climate change' and 'poverty'. India is a highly populated country in the world, and hence its energy need is also more and growing with time. In most countries of equatorial Africa and Indian states it is difficult to satisfy power demand all year long by hydro sources alone. Hence it is necessary to interconnect other renewable/alternative energy sources for reliability and consistence power supply. Renewable energy sources offer a viable alternative to the provision of power in rural areas [1-5]. One of the widely available energy sources is the solar energy. Seasonal variations of wind and solar resources are complementary to each other. Wind energy in India: Status and future prospects are presented and discussed [6]. A consistent exploitation of the complementarities of these two sources of energy with battery storage and diesel generator as backup seems necessary to maintain a consistent level of electricity production in favorable sites. Therefore, much research is conducted on minimization of usage of diesel fuel.

The potential negative environmental impacts of hydropower are:

1. Resettlement and disruption of communities.
2. Destructions and/or modifications to forests, wildlife habitats and hydrological regime.

Although, hydropower projects can have major impacts on the environment due to increasing concerns over air quality, the use of small, or 'micro' hydropower schemes are

likely to become an alternative and attractive means of expanding energy supply to rural areas and is eco friendly. Technological advancement, high expected lifetime and low maintenance costs makes hydro an ideal source for locations with access to flow-of-river. Even a small contribution of hydro may already be valuable [7].

The alternative/renewable energy sources such as solar energy, wind energy and micro/small hydro-power plant have the greater potential to generate power for system utilities. The abundant energy available in nature can be harnessed and converted to electricity in a sustainable and clean way to supply the necessary power to elevate the living standards of people without access to the electricity grid. If stability is concerned with available voltage and power variation, these problems can be solved by integrating the possible alternative/renewable energy sources. The concept of hybridizing renewable energy sources is that the base load is to be covered by largest and firmly available renewable source(s) and other intermittent source(s) should augment the base load to cover the peak load of an isolated mini electric grid system.

The hybrid power systems which utilize renewable energy generators can be classified into two basic configurations: Series hybrid system and Parallel hybrid system [4]. Both the systems have their own characteristics. The proposed scheme is based on parallel hybrid system.

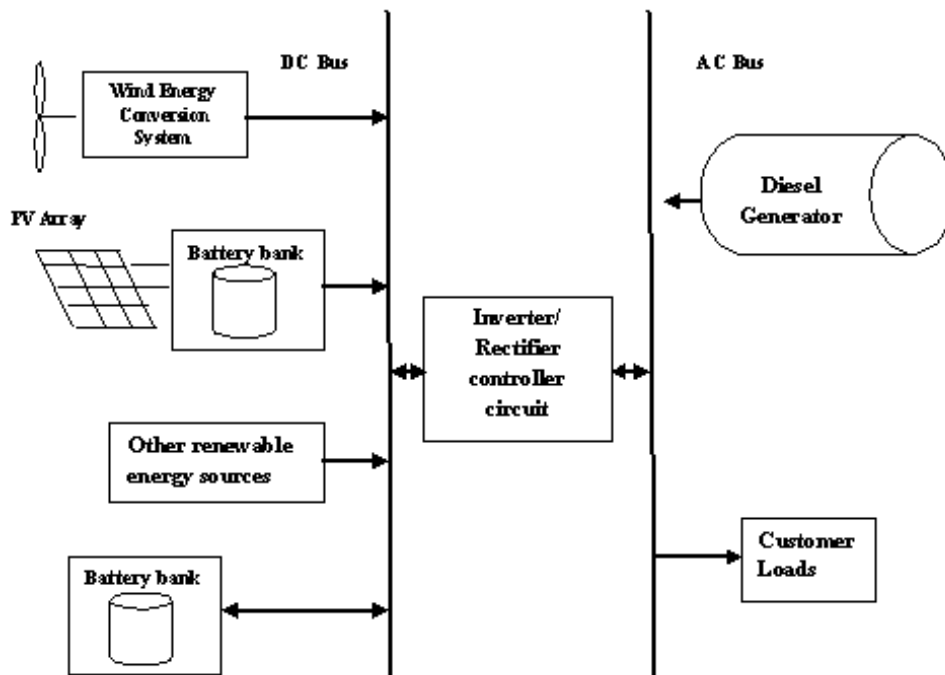

Figure 1. Parallel hybrid renewable/alternative energy system

The wind turbine is the largest supplier of energy to this system and the fluctuation of wind power with time, together with the household demand, are the only external variables influencing the system. The base load is to be covered by firmly available micro hydro plant. The PV systems with battery banks share some of the loads. The diesel generators and battery banks are used as a back-up electricity source [8, 9].

Here a case study is given based on the practically available data with analysis using computer software. HOMER software means Hybrid Optimization Model for Electric Renewable [10, 11]. HOMER is a micro-power optimization model that simplifies the task of evaluating power system designs in a variety of applications. As HOMER does both optimization and sensitivity analysis, it makes easier to evaluate many possible system configurations of the large number of technology options and the variation in technology

costs and availability of energy resources. Solar, wind and hydro data are collected [12-16]. Many literature references have discussed on sizing and to determine the optimum combination of a hybrid energy system [5, 17, 18]. Many have presents a comparison study to determine the optimal configuration of power sources relevant to different regions [2].

Many hybrid systems have been proposed in the past for electrification of remote areas or grid connected sites. Many tools are also available for sizing and simulation of a hybrid system. But fewer include hydro resources [19, 20]. The performance of hybrid system is dependent on the environmental conditions, analysis is considered in the given study area to investigate the associated cost and component size. The diesel fuel price, the wind speed and solar radiation as a sensitivity variable are collected to determine the effect of these variables on the cost of the system and the optimal system configuration. The authors have adopted a new approach to the PV/Wind/ diesel hybrid system including a hydro resource and comparing it with excluding it. The paper is organized as follows. Study area and water resources availability is discussed in section 2. Energy demand and resources for the proposed scheme are discussed in section 3. The hybrid system proposed is consists of micro hydro plant, wind turbine and solar photovoltaic (PV) panels. Diesel generators and battery bank are included as part of back-up and storage system. Mathematical modeling of hybrid energy system components are given in section 4 and analysis is done in section 5. Homer hybrid model is given in section 6. The project lifetime is estimated for about 25 years. The results obtained from Homer simulation is discussed in section 7. Also simulation is done and presented without hydro plants and discussed in section 8.

2. Study Area and Water Resources

Figure 2 shows the geographical location of the study area on the map [12]. The study area under consideration is located in the Sundargarh district of Orissa state, India. Sundargarh geographically extends over the North-Western portion of the state and is located between 21⁰35' N and 22⁰32' N latitudes and 83⁰32' E and 85⁰22' E longitudes. The district covers an area of 9712 Sq Kms.

The Ib and the Brahmani are the two principal rivers in Sundargarh district which flow for lengths of 96 km and 83 km respectively [12]. The river Ib originates from the Khudia plateau in the Ex-state of Jaspur in Chhattisgarh and enters the district from the North at Tilijore. It passes through Sundargarh district to meet the river Mahanadi in Sambalpur distict. The Tunga and the Ichha rivers along the western bank and the Safei on the Eastern bank are the principal tributaries of Ib. The confluence of the Koel and the Sankha rivers at Panposh is the origin of the river Brahmani. Besides these two major rivers, a number of tributaries, distributaries, canals, and hills streams also flow through the district. The hot season begins in March and end in May, when the temperature ranges between 41⁰ C and 49⁰ C. Arrival of monsoon by mid-June brings respite from the heat and temperature begins to fall from mid-June onwards. Winter starts from November and reaches a low of 30⁰ to 40⁰ Celsius during December and January. The district receives maximum rainfall between June and September through south-west monsoon. The average rainfall of this district has been recorded at 1647.6 mm (or 64.862"). The month of July gets the heaviest rainfall of the year, though rainfall is not very regular throughout the season but fairly uniform throughout the district. Besides, the relative humidity varies between 30 % and 86%. The district faces occasional flash floods which, because of the terrain, cause heavy damage to roads and crops. Though the normal rainfall is 1647.6 mm, rainfall has mostly been erratic. Forests, which cover about 51.07% of the total area of the district, play a very important role in the economy of this tribal district.

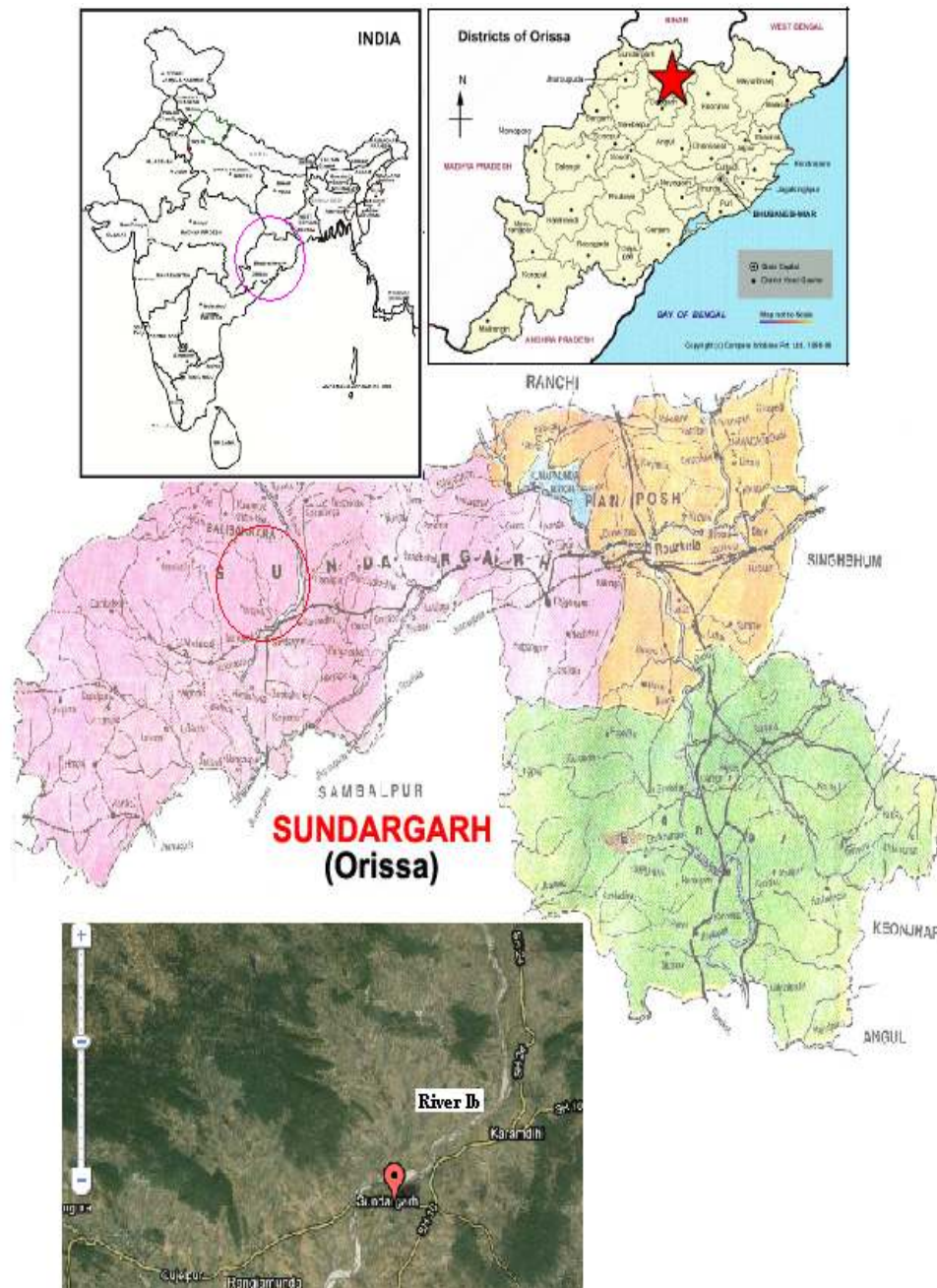

Figure 2. Study area

List of symbols			
t	Time in Hour	$P_{WEG}(t)$	Electrical power generated by wind generator
Q	Discharge in m^3/s	$E_{WEG}(t)$	Hourly energy generated by wind generator
ρ_{Water}	Density of water = 1000 kg/m^3	η_{INV}	Efficiency of inverter
h	Head in metre	$E_{PVG-IN}(t)$	Hourly energy output from inverter (in case of SPV), kWh
η_{Hydro}	Hydro efficiency	η_{CHG}	Battery charging efficiency
P_{MHP}	Electrical power generated by micro hydropower generator	η_{DCHG}	Battery discharging efficiency
$E_{MHP}(t)$	Electrical energy generated by micro hydropower generator	$E_{BAT}(t)$	Energy stored in battery at hour t, kWh
A	Surface area of the PV modules in m^2	$E_{BAT}(t-1)$	Energy stored in battery at hour t-1, kWh
P	PV penetration level factor	$E_{BAT-INV}(t)$	Hourly energy output from inverter (in case of battery), kWh
η_{PVG}	Efficiency of PV generator	$E_{SUR-AC}(t)$	Amount of surplus energy from AC sources, kWh
$G(t)$	Hourly irradiance in kWh/m^2	$E_{Load}(t)$	Hourly energy consumed by the load side, kWh
$E_{PVG}(t)$	Hourly energy output of the PV generator	η_{REC}	Efficiency of rectifier
$E_{DEG}(t)$	Hourly energy generated by diesel generator	$E_{REC-IN}(t)$	Hourly energy input to rectifier, kWh
P_{DEG}	Rated power output by diesel generator	$E_{REC-OUT}(t)$	Hourly energy output from rectifier, kWh
η_{DEG}	Diesel generator efficiency	C_{MHP}	Capital cost of micro hydro plant
η_{CC}	Efficiency of charge controller	C_{WEG}	Capital cost of wind energy system
$E_{CC-IN}(t)$	Hourly energy input to charge controller, kWh	C_{PVG}	Capital cost of PV generator system
$E_{CC-OUT}(t)$	Hourly energy output from charge controller, kWh	C_{DEG}	Capital cost of diesel generator unit
ρ_{Wind}	Density of air in $1.22Kg / m^3$	C_{BAT}	Capital cost of battery system
C_P	Performance coefficient of the turbine	C_F	Fixed cost include cost of converter and other installation cost
λ	Tip speed ratio of the rotor blade tip speed to wind speed	C_C	Total capital cost
β	Blade pitch angle (deg) as 0°	C_O	Annual operating cost
v	Wind speed (m/s)	C_{Annual}	Total annualized life cycle cost of the system
η_t	Wind turbine efficiency	CRF	Capital recovery factor for the system with expected discount rate
η_g	Generator efficiency	E_T	Total load served in kWh/year

3. Energy Demand and Resources

A. Load/demand assessment

The electrical loads of the area are classified as domestic, agricultural, community and rural industries. The domestic sector needs electricity for electrical appliances such as TV, fan and compact fluorescent lamps. The agricultural load includes irrigation, fodder cutting and crop threshing machines. The community load includes schools and village government office buildings. The rural industries such as milk storage and small-scale milk processing plants have been considered for these villages.

B. Solar radiation and Wind resources

Monthly clearness index and daily radiation profile as a monthly average for a year obtained through Homer is given in Figure3. The data is collected for latitude $21^{\circ} 35'$ North and longitude $83^{\circ} 32'$ East [16]. Monthly wind speed data are collected [16], which is shown in Figure4. Figure 5 shows wind speed probability distribution.

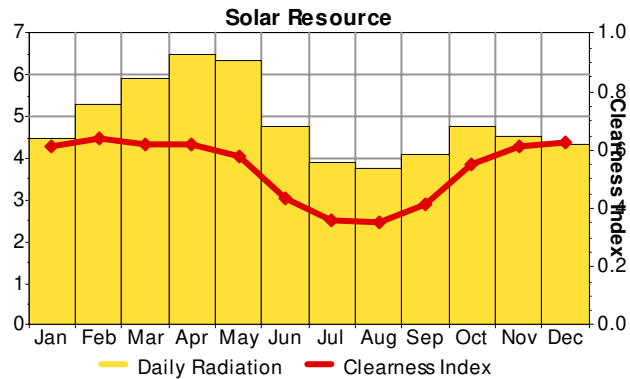

Figure 3. Monthly average daily radiation and clearness index

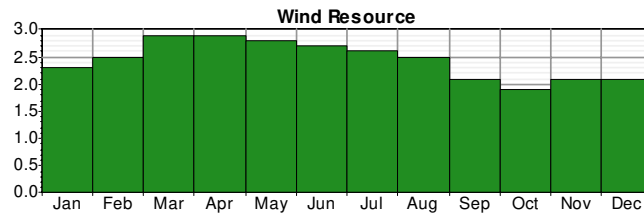

Figure 4. Monthly average wind speed

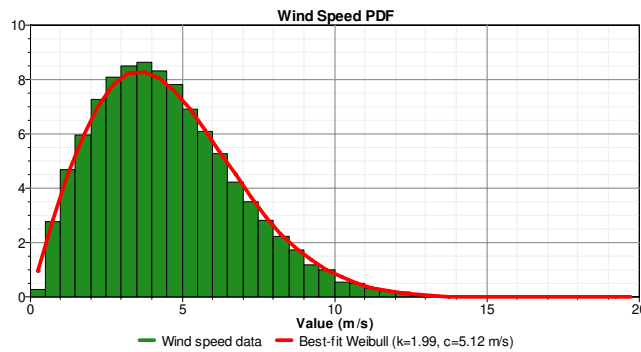

Figure 5. Wind speed probability distribution

C. Micro hydro plant

The barriers perceived in development of the small/micro hydro segment are technical, procedural and cost-related in nature [14]. The technical barriers include factors such as accessibility to the sites and risks involved in transporting heavy equipments to the sites. The procedural issues primarily relate to the number of clearances required before taking the project. Typically, a developer is required to get a project allotment from the state nodal agency, obtain clearance from Ministry of Environment and Forests where forestland is involved (in projects costing more than \$20 millions), clearance from the Irrigation/Water Resources Department, clearance from the state government on land availability, etc. In some areas security problems are also experienced due to insurgency. On the cost front, it is a matter of some concern that equipment prices are not going down due to the limited number of players. Ministry of Non-Conventional Energy Resources supports for Off-grid Micro Hydro Projects for Rural Electrification Up to 100 kW. In average all over India the present capital cost of micro hydro plant is \$3000/kW. Operation and Maintenance costs 2% of capital costs [21].

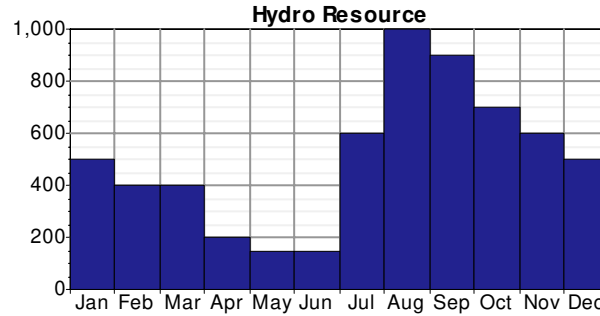

Figure 6. Monthly average water flow

4. Modeling of Hybrid Energy System Components

Before going to the computer simulation, mathematical modeling of hybrid energy system components is described below. The proposed system contains micro hydro generating sub-system, wind energy sub-system, PV sub-system, diesel generators unit and battery storage sub-system. The theoretical aspects are given below and based on Figure7 [3, 22].

A. Mathematical model of micro-hydro generator

In the proposed scheme the micro hydro generator will supply power to the base load. The capacity factor of the resources is taken as unity. The sub-system is considered as run of river with small pondage. The available power will be dependent of seasonal variation of the resources. The electrical power generated by small hydropower generator is given by,

$$P_{MHP}(t) = \eta_{Hydro} \frac{9.81 \times Q \times \rho_{Water} \times h}{1000} \quad (1)$$

And the total energy in kWh is given by

$$E_{MHP}(t) = P_{MHP}(t) \times t \quad (2)$$

B. Mathematical model of Solar Photovoltaic generator

Using the solar radiation available on the tilted surface the hourly energy output (E_{PVG}) of the PV generator can be calculated according to the following equation:

$$E_{PVG} = G(t) \times A \times P \times \eta_{PVG} \quad (3)$$

Here assumes that the temperature effects (on PV cells) are ignored.

C. Mathematical model of wind energy generator

Hourly energy generated (E_{WEG}) by wind generator with rated power output (P_{WEG}) is defined by the following expression:

$$P_{WEG} = \frac{1}{2} \rho_{Wind} A v^3 C_p(\lambda, \beta) \times \eta_t \times \eta_g \quad (4)$$

$$E_{WEG}(t) = P_{WEG} \times t \quad (5)$$

D. Mathematical model of diesel generator

Hourly energy generated (E_{DEG}) by diesel generator with rated power output (P_{DEG}) is defined by the following expression:

$$E_{DEG}(t) = P_{DEG}(t) \times \eta_{DEG} \quad (6)$$

For better performance and higher efficiency the diesel generator will always operate between 80 and 100% of their kW rating.

E. Mathematical model of converter

In the proposed scheme converter contains both rectifier and inverter. PV generator and battery sub-systems are connected with DC bus. Hydro, wind energy generator and diesel generating unit sub-systems are connected with AC bus. The electric loads connected in this scheme are AC loads.

The inverter model for photovoltaic generator and battery bank are given below:

$$E_{PVG-INV}(t) = E_{PVG}(t) \times \eta_{INV} \quad (7)$$

$$E_{BAT-INV}(t) = [(E_{BAT}(t-1) - E_{Load}(t)) / (\eta_{INV} \times \eta_{DCHG})] \quad (8)$$

The rectifier is used to transform the surplus AC power from the micro hydro unit, wind energy generator and diesel electric generator to DC power of constant voltage, when the energy generated by the hybrid energy system exceeds the load demand. The rectifier model is given below:

$$E_{REC-OUT}(t) = E_{REC-IN}(t) \times \eta_{REC} \quad (9)$$

$$E_{REC-IN}(t) = E_{SUR-AC}(t) \quad (10)$$

At any time t,

$$E_{SUR-AC}(t) = E_{SHP}(t) + E_{WEG}(t) + E_{DEG}(t) - E_{Load}(t) \quad (11)$$

F. Mathematical model of charge controller

To prevent overcharging of a battery, a charge controller is used to sense when the batteries are fully charged and to stop or decrease the amount of energy flowing from the energy source to the batteries. The model of the charge controller is presented below:

$$E_{CC-OUT}(t) = E_{CC-IN}(t) \times \eta_{CC} \quad (12)$$

$$E_{CC-IN}(t) = E_{REC-OUT}(t) + E_{SUR-DC}(t) \quad (13)$$

G. Mathematical model of battery bank

The battery state of charge (SOC) is the cumulative sum of the daily charge/discharge transfers. At any hour t the state of battery is related to the previous state of charge and to the energy production and consumption situation of the system during the time from t-1 to t.

During the charging process, when the total output of all generators exceeds the load demand, the available battery bank capacity at hour t can be described by,

$$E_{BAT}(t) = E_{BAT}(t-1) - E_{CC-OUT}(t) \times \eta_{CHG} \quad (14)$$

On the other hand, when the load demand is greater than the available energy generated, the battery bank is in discharging state. Therefore, the available battery bank capacity at hour t can be expressed as:

$$E_{BAT}(t) = E_{BAT}(t-1) - E_{Needed}(t) \quad (15)$$

Let d be the ratio of minimum allowable SOC voltage limit to the maximum SOC voltage across the battery terminals when it is fully charged.

So, the Depth of Discharge (DOD)

$$DOD = (1 - d) \times 100 \quad (16)$$

DOD is a measure of how much energy has been withdrawn from a storage device, expressed as a percentage of full capacity. The maximum value of SOC is 1, and the minimum SOC is determined by maximum depth of discharge (DOD),

$$SOC_{Min} = 1 - \frac{DOD}{100} \quad (17)$$

5. Proposed Model Analysis

Total hybrid power generated at any time t ,

$$P(t) = \sum_{MHP=1}^{N_H} P_{MHP} + \sum_{WEG=1}^{N_W} P_{WEG} + \sum_{PVG=1}^{N_P} P_{PVG} + \sum_{DEG=1}^{N_D} P_{DEG} \quad (18)$$

Where N_M, N_W, N_P, N_D , are number of units of micro-hydro generators, wind generators, number of PV cells and of diesel generators unit respectively. This generated power will feed to the loads. The diesel generator has the constraint to always operate between 80 and 100% of their kW rating. When this generated power exceeds the load demand then the surplus of energy will be stored in the battery bank. This energy will be used when deficiency of power occur to meet the load. The charged quantity of the battery bank has the constraint $SOC_{MIN} \leq SOC(t) \leq SOC_{MAX}$. The dump load will draw excess energy produced by the renewable generators or diesel generators but unused when the load does not need all the energy and the battery has reached its maximum capacity and can not store more energy. The approach involves the minimization of a cost function subject to a set of equality and inequality constraints. The total capital cost C_C for the proposed combination of PV-Wind-micro-hydro hybrid system is given by,

$$C_C = \sum_{MHP=1}^{N_H} C_{MHP} + \sum_{WEG=1}^{N_W} C_{WEG} + \sum_{PVG=1}^{N_P} C_{PVG} + \sum_{DEG=1}^{N_D} C_{DEG} + \sum_{B=1}^{N_B} C_{Bat} + C_F \quad (19)$$

The annual operating cost C_o computed based on the operating costs of all the installed units for the interval t in a day as shown below.

$$C_o = \sum_{t=1}^{365} \left\{ \sum_{t=1}^{24} (C_{OMHP}(t) + C_{OWEG}(t) + C_{OPVG}(t) + C_{ODEG}(t) + C_{OBat}(t) + C_{OF}(t)) \right\} \quad (20)$$

Total annualized life cycle cost of the system comprises both capital and operating cost,

$$C_{Annual} = (C_C \cdot CRF + C_O) \quad (21)$$

Unit cost of electricity by hybrid energy system,

$$COE = \frac{C_{Annual}}{E_T} \quad (22)$$

6. HOMER Simulation

The renewable energy as well as conventional power generating technologies can be modeled through HOMER. Graphical results help identify market opportunities and barriers for each micro power technology. HOMER helps determine how different conventional, renewable, and hybrid systems interact with end-use demand. Based on the availability and

potential of renewable energies in the study area a hybrid energy system is modelled consisting of wind turbine and solar PV system along with DGs back-up, battery storage. The details of various parameters such as solar and wind resource potential of the area, load profile of the intended village cluster and description of various components, i.e. size, number and cost of wind turbine, PV array, DG, battery, converter, etc. in the proposed hybrid scheme have been collected from different resources.

A. Micro-hydro model

Water resources are discussed in section 3. The selected site is rich from water resources. The micro hydro model in Homer software is not designed for a particular water resource. Certain assumptions are taken about available head, design flow rate, maximum and minimum flow ratio and efficiency to the turbines. The available head is assumed to be 10 m and designed flow rate as 1000 L/s. The life time of the micro hydro model in simulation is taken as 50 years. The sub system is designed for 100 kW of capacity having capital cost \$300000. The replacement price of \$300000 and O/M costs is 2% of capital costs of \$6000.

B. Wind turbine model

The monthly wind speed data is given in Figure5 measured at 10m height [16]. The number of WES 18 wind turbines considered for simulation is eight. The capital, replacement and O&M costs of the turbine have been given in Table I. The projected lifetime of the wind turbine is 25 years i.e. end of the project.

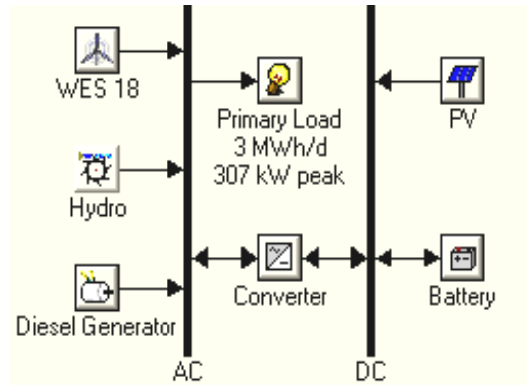

Figure 7. Proposed scheme of hybrid energy generation for the study area in HOMER software model

Table 1. Details of the capital, replacement and O&M costs of various equipments employed in the proposed scheme [2].

Component detail	Capital cost (\$)	Replacement cost (\$)	O&M cost (\$/yr)
Solar PV system (1 kW)	5600	5000	10
Wind turbine	11,000	10,000	110
Battery (6V, 6.94kWh)	700	600	0.1
Converter(1 kW)	140	126	15
Diesel Generator (70 kW)	18000	18000	0.15 \$/h

C. PV array model

The latitude of the site is 21° 30 min North, and the longitude is 83° 32 min East. The time zone is GMT +05:30. The daily solar radiation – horizontal data are taken for simulation [16]. There are 200 PV panels with each has a capacity of 1 kW. The capital, replacement and O&M

costs each panels of 1 kW have been given in Table I. The projected lifetime of the PV array is 25 years. The PV plant considered here has no tracking system.

D. Battery model

The variations of solar and wind energy generation do not match the time distribution of the demand. Therefore, power generation systems dictate the association of battery storage facility to smooth the time–distribution mismatch between the load and solar/wind energy generation and to account for maintenance of the systems. Batteries are considered as a major cost factor in small-scale stand-alone power systems. The battery stacks may contain a number of batteries range from 0 – 500 units. A battery of 4V, 7.6kWh has been chosen. The cost of a battery, its replacement and O&M costs as used for simulation are shown in Table I.

E. Diesel Generator model

The study included a sensitivity analysis on the price of diesel fuel. This price can vary considerably based on region, transportation costs, and current market price. The price of diesel fuel for the simulation is taken as \$0.8/L based on present price in India as on October, 2010. Also the simulations include diesel fuels cost \$0.9/L, \$1.00/L, \$ 1.1/L and \$1.2/L. The capital cost is given in table I. The diesel back-up system is operated at times when the output from wind and solar systems fails to satisfy the load and when the battery storage is depleted.

F. Converter

Here converter is used which can work both as an inverter and rectifier depending on the direction of flow of power. In the present case, the size of the converter ranges from 0 to 500 kW for simulation purposes.

G. Connected electric load

Electrical load is one or more devices that consume electric energy. The data were measured for the total hourly basis daily electrical load requirement of a residential of a small block of sundargarh district. The name of the block is Hemgir. The expected load consumption profile of the area is shown in Figure 8. The daily load requirement of the intended village cluster is found to be 2975 kWh per day and the peak load is found to be 307 kW.

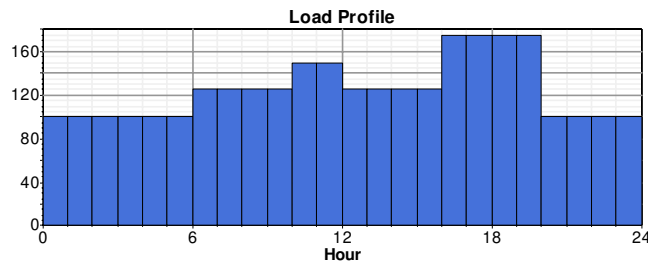

Figure 8. Hourly load consumption

7. Results and Discussions

HOMER simulates system configurations with all of the combinations of components that were specified in the component input. HOMER performs hundreds or thousands of hourly simulations (to ensure best possible matching of demand and supply) and offers a list of feasible schemes ranked on the basis of the NPC (net present cost). The strategy taken in this simulation is to ensure the power generator provide enough power to meet the demand. The renewable energy sources in collaboration with the micro hydro and diesel generators were evaluated to determine the feasibility of the system. The system is also simulated in order to evaluate its operational characteristics, namely annual electrical energy production, annual

electrical load served, excess electricity, renewable energy fraction, capacity shortage and unmet electric load as shown in Figure10 to Figure 17.

In the months of July and August on a cloudy, windy day when solar photovoltaic cells are producing lower levels of energy, a wind generator is producing a lot of energy as shown in Figure11. The results show that in the months of May and June when flow of water is very low the Diesel Generator is supplying considerable amount of power to the loads to meet peak load demands. The simulation is done for five different costs of diesel fuels as \$0.8/L, \$0.9/L, \$1.00/L, \$ 1.1/L and \$1.2/L and the simulation results are shown in Figure9. The economic balance between micro-hydro and rest of the scheme at any time depends upon the nature of the load curve, run-off and its seasonal variation and cost of fuel etc. The run-of-river plant can be used as base load plant during rainy season and may work as peak load plant during dry season. For the optimum solution of the proposed model the COE is found to be \$0.207/kWh, which is slightly higher than the COE from conventional sources at present. But we hope that in the competitive market if installation cost decrease and further technological advancement to the design of hybrid models the COE at present calculated value will also decrease.

Sensitivity Results | Optimization Results

Tabular Graphic

Export

Double click on a system below for optimization results.

Diesel (\$/L)	PV (kW)	wES18	Hydro (kW)	DG (kW)	Batt. (kW)	Conv. (kW)	Initial Capital	Total NPC	COE (\$/kWh)	Ren. Frac.	Diesel (L)	DG (hrs)
0.800	200	8	73.6	250	500	500	\$ 1,914,086	\$ 2,687,272	0.194	0.93	43,022	656
0.900	200	8	73.6	250	500	500	\$ 1,914,086	\$ 2,742,268	0.198	0.93	43,022	656
1.000	200	8	73.6	250	500	500	\$ 1,914,086	\$ 2,797,263	0.202	0.93	43,022	656
1.100	200	8	73.6	250	500	500	\$ 1,914,086	\$ 2,852,259	0.205	0.93	43,022	656
1.200	200	8	73.6	250	500	500	\$ 1,914,086	\$ 2,907,255	0.209	0.93	43,022	656

Figure 9. The simulation results for PV-wind-diesel energy system

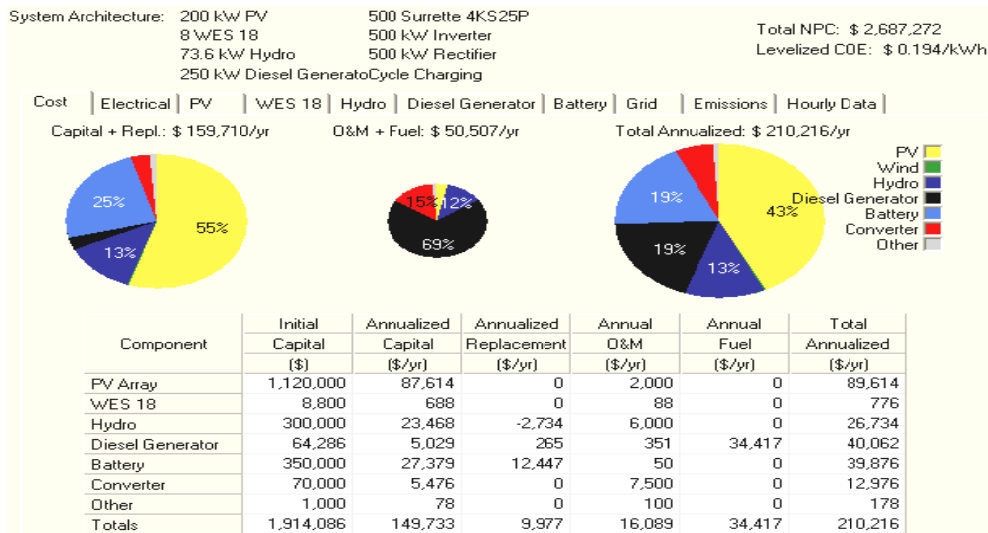

Figure 10. Cost sheet of the optimum system

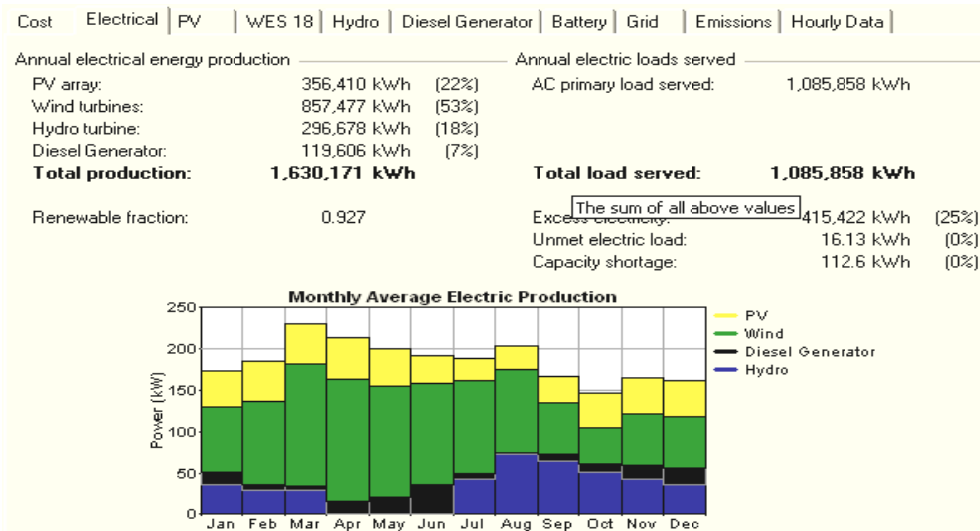

Figure 11. Contribution of electrical energy production by various energy sources in the optimal system.

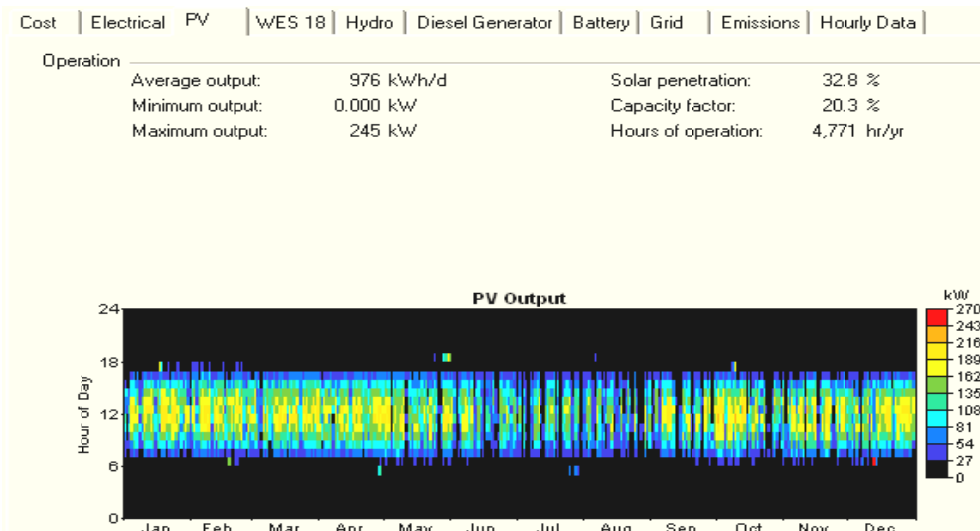

Figure 12. Annual electric production of PV system

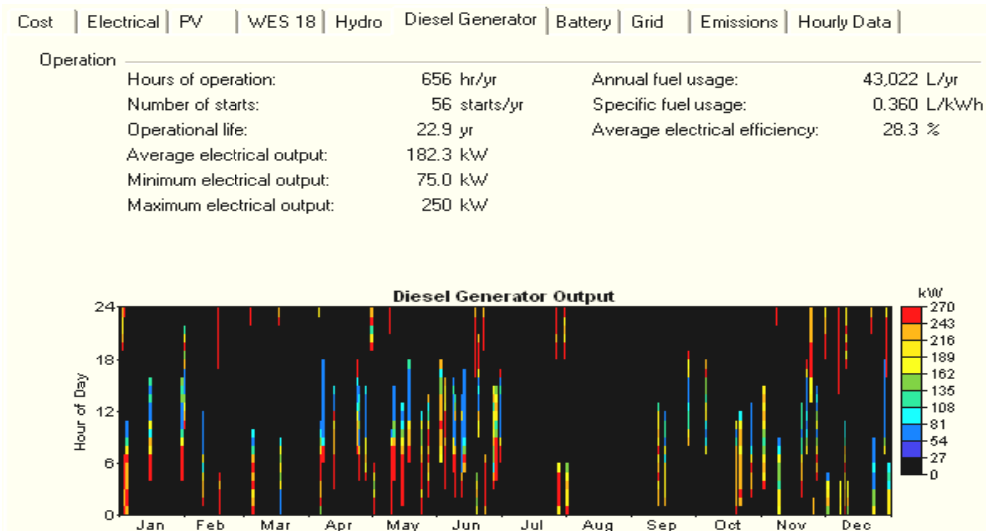

Figure 13. Annual electric production of Diesel Generator

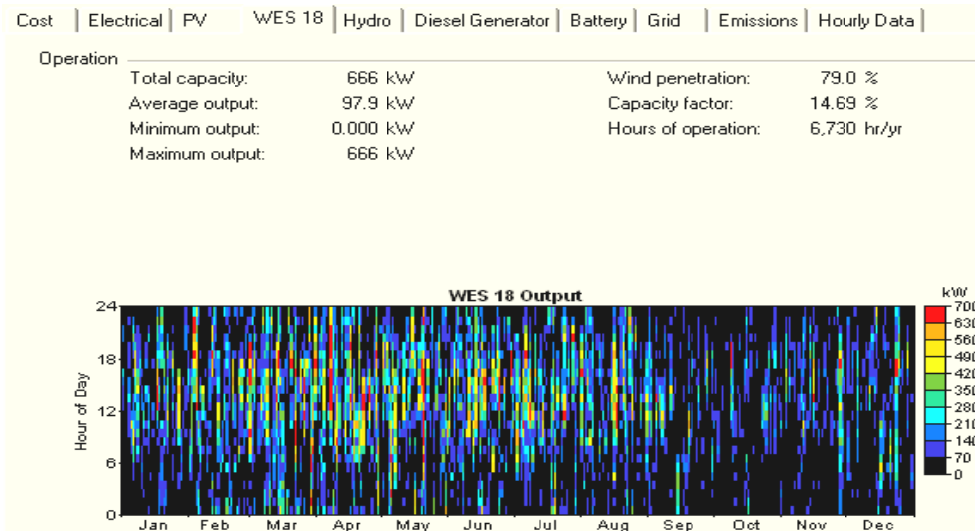

Figure 14. Annual electric production of wind energy generator

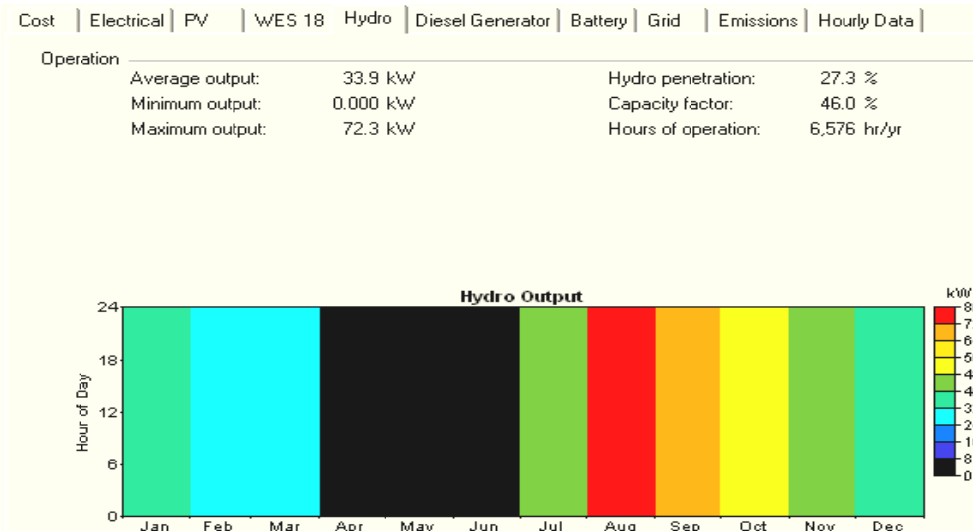

Figure15. Annual electrical energy production of hydro plant

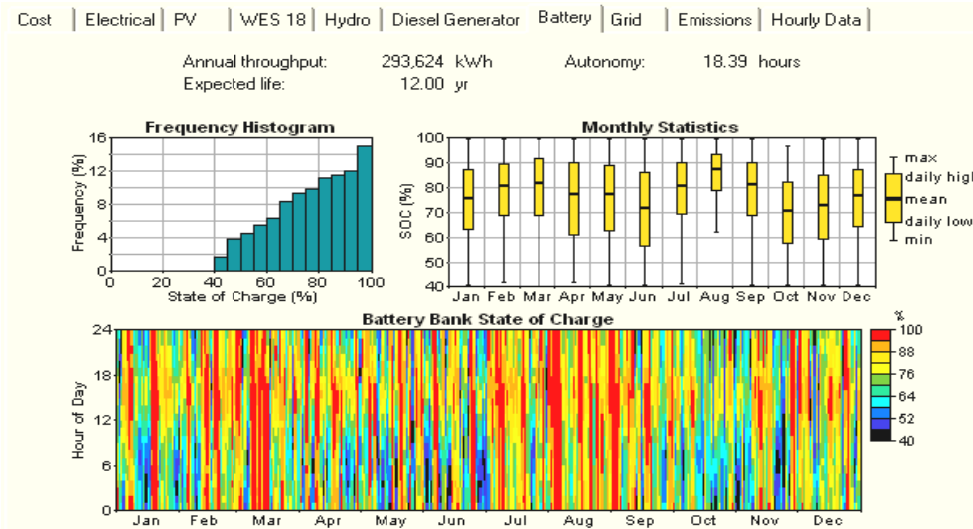

Figure16. Statistical results of battery system

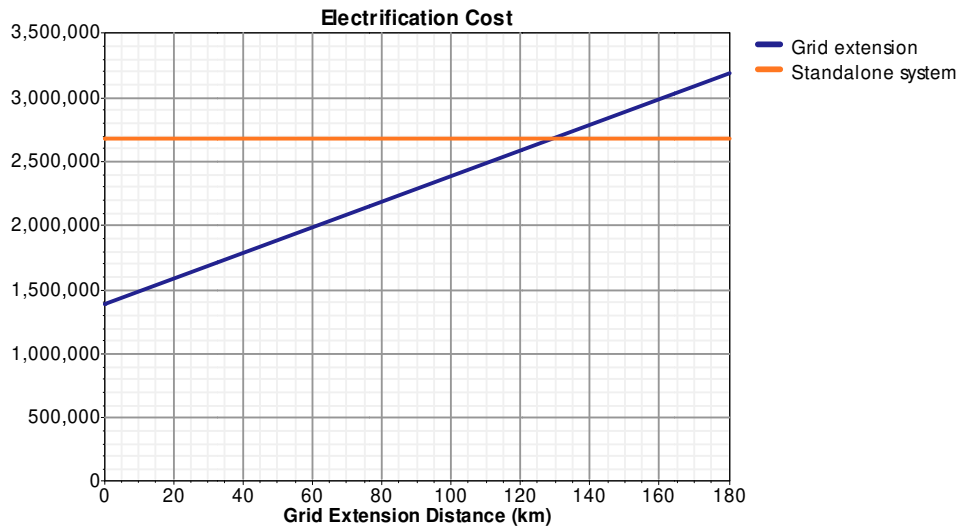

Figure17. Break-even grid distance

8. PV-wind-diesel system simulation without hydro and its comparison with the proposed scheme

Figure 18 and Figure 19 shows the cost summary and contribution of electrical energy production by various energy sources in the system respectively without micro-hydro plant for diesel cost of \$0.8. The contribution of electrical power by diesel generators increases in absence of micro-hydro plant. The simulation results show that the cost of energy increases with increase in electric power output by diesel generators unit.

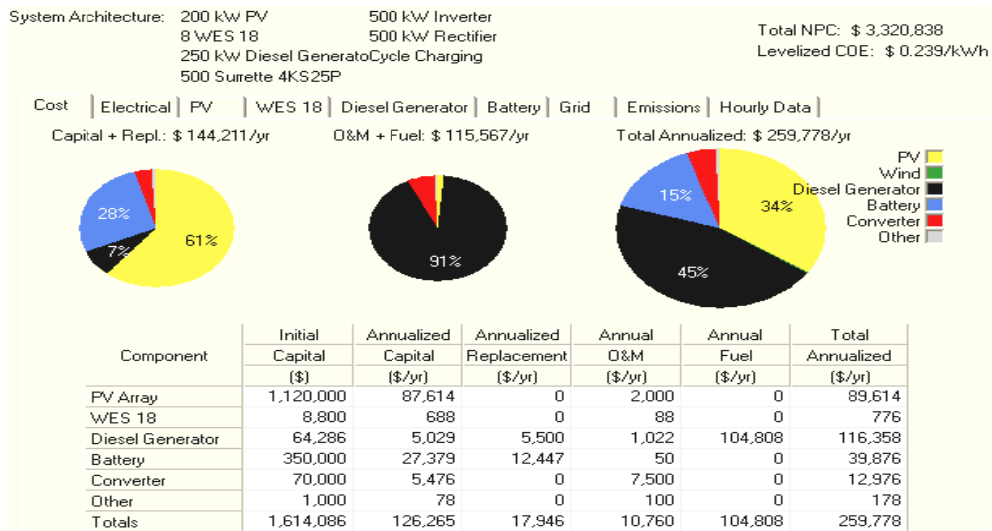

Figure18. Cost sheet of the optimum system without micro-hydro plant.

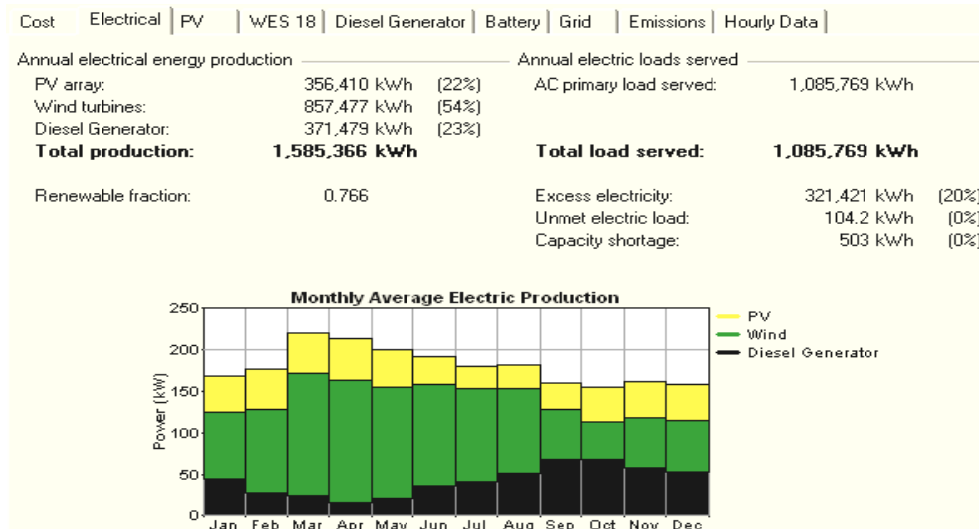

Figure19 Contribution of electrical energy production by various energy sources in the system without micro-hydro plant.

9. Conclusions

The main criterion for sustainable development is that all key factors interacting within a global system should be in equilibrium. For a sustainable materials development it needs optimum combinations between three factors: Economy, Ecology and Energy. Any increase in one of these factors may worsen the other factors and the balance is disturbed. The renewable energy sources are eco-friendly, the main intention of this paper is to suggest the proposed scheme based on the balance among economy, environment and energy. HOMER software was used to determine the optimum hybrid configuration. The comparison is also made between with and without micro-hydro plant. The availability of different renewable energy sources is highly variable and site specific and the comparison suggests us that there is a need of integrated renewable energy systems which reduce the dependencies on diesel generating units and other conventional energy sources. The simulation results show that the cost of energy in the proposed scheme is comparably higher than the conventional energy sources. But this scheme is highly preferable for rural and remote areas where installations and O&M to extended grid systems are very difficult and costly. A hybrid energy system, where electricity is generated using multiple renewable sources significantly improves efficiency, and the sustainability of such a system. The lots of work need to be done in the field of integrating hybrid power system. An important study is the behaviour of hybrid system which allows employing renewable and variable in time energy sources while providing a continuous supply. More study for wind availability and daily wind speed and solar radiation data was required to precisely evaluated wind/PV generation economics.

References

- [1] A.B. Kanase-Patil, R.P. Saini, M.P. Sharma, “Integrated renewable energy systems for off grid rural electrification of remote area”, *Renewable Energy* 35 (2010), pp. 1342–1349.
- [2] Rajoriya, E. Fernandez, “Sustainable energy generation using hybrid energy system for remote hilly rural area in India”, *International Journal of Sustainable Engineering*, May 2010, pp. 1–9.
- [3] Ajai Gupta, R.P. Saini, M.P. Sharma, “Steady-state modeling of hybrid energy system for off grid electrification of cluster of villages”, *Renewable Energy* 35 (2010) pp. 520–535.

- [4] Ahmad Agus Setiawan, Yu Zhao, Chem. V. Nayar, “Design, economic analysis and environmental considerations of mini-grid hybrid power system with reverse osmosis desalination plant for remote areas”, *Renewable Energy* 34 (2009) pp. 374–383.
- [5] Akella A.K., Sharma M.P. and Saini R.P., Optimum utilization of renewable energy sources in a remote area, *Renewable and Sustainable Energy Reviews* 11 (2007), pp. 894–908.
- [6] Ishan Purohit, Pallav Purohit, “Wind energy in India: Status and future prospects”. *Journal of Renewable and Sustainable Energy* 1 (2009).
- [7] Joseph Kenfack, François Pascal Neirac, Thomas Tamo Tatietse, Didier Mayer, Me´dard Fogue, Andre´ Lejeune, “Micro hydro-PV-hybrid system: Sizing a small hydro-PV-hybrid system for rural electrification in developing countries”, *Renewable Energy* 34 (2009) pp. 2259–2263.
- [8] R. D. Prasad, “A Case Study for Energy Output using a Single Wind Turbine and a Hybrid System for Vadravadra Site in Fiji Islands”, *The Online Journal on Power and Energy Engineering (OJPEE)*, Vol. (1) – No. (1), pp. 22-25.
- [9] Mohd Zamri Ibrahim, Roziah Zailan, Marzuki Ismail and Abdul Majeed Muzathik, “Pre-feasibility Study of Hybrid Hydrogen Based Energy Systems for Coastal Residential Applications”, *Energy Research Journal* 1 (1): pp. 12-21, 2010.
- [10] P. Lilienthal, L. Flowers, “HOMER: The Hybrid Optimization Model for Electric Renewable”, in *Proc. Wind power '95*, American Wind Energy Association, Washington, DC, 27-30 March 1995, pp. 475-480.
- [11] R. D. Prasad, “A Case Study for Energy Output using a Single Wind Turbine and a Hybrid System for Vadravadra Site in Fiji Islands”, *The Online Journal on Power and Energy Engineering (OJPEE)*, Vol. (1) – No. (1), pp. 22-25.
- [12] District Plan Report (2009-2010), SUNDARGARH District, ORISSA, prepared by district administration, Sundargarh & centre for youth & social development.
- [13] Wind energy resources survey in India Volume – VI, 2001. Publication for sale by Centre for Wind Energy Technology (C-WET) India.
- [14] K. Ramanathan, P. Abeygunawardena, Reference document on hydropower development in India, Published 2007.
- [15] Solar Radiation Hand Book (2008), Typical Climatic Data for Selected Radiation Stations (The Data Period Covered: 1986-2000), a joint Project of Solar Energy Centre, MNRE & Indian Metrological Department.
- [16] <http://eosweb.larc.nasa.gov/cgi-bin/sse/retscreen.cgi?email=rets@nrcan.gc.ca&step=1&lat =22.06&lon=84&submit=Submit> accessed on October 26, 2010.
- [17] Juhari Ab. Razak, Kamaruzzaman Sopian, Yusoff Ali, Mohammad Ahmed Alghoul, Azami Zaharim, Ibrahim Ahmad, “Optimization of PV-Wind-Hydro-Diesel Hybrid System by Minimizing Excess Capacity”, *European Journal of Scientific Research*, Vol.25 No.4 (2009), pp.663-671.
- [18] Hani S. Alganahi, Kamaruzzaman S., Mohamed A., Ahmed M.A. Haidar, Ahmed N. Abdalla, “Experimental Study of Using Renewable Energy in Yemen”, *Australian Journal of Basic and Applied Sciences*, 3(4): pp. 4170-4174, 2009.
- [19] S.G. Jimmy Ehnberga, Math H.J. Bollen, “Reliability of a small power system using solar power and hydro”, *Electric Power Systems Research* 74 (2005) pp. 119–127.
- [20] O.A. Jaramillo, M.A. Borja, J.M. Huacuz, “Using hydropower to complement wind energy: a hybrid system to provide firm power”, *Renewable Energy* 29 (2004) pp. 1887–1909.
- [21] <http://environmentpress.in/headlines/water-and-energy-%E2%80%93-decentralised-small-and-micro-hydro-power-generation-in-india/> accessed on October 19, 2010.
- [22] S. Ashok, Optimized model for community-based hybrid energy system, *Renewable Energy* 32 (2007) pp. 1155–1164.



Deepak Kumar Lal was born in Orissa state, India, 1984. He received his B. Tech degree from Biju Patnaik University of Technology, Orissa in 2008, and M.Tech from National Institute of Technology – Jamshedpur, India in 2010. Presently he holds the post of Lecturer, Department of Electrical Engineering, VSS University of Technology, Odisha, India. His areas of major interests are Renewable Energy Technologies, Computer Simulation, Analysis, and Control of Power System.



Bibhuti Bhusan Dash was born in Orissa, India, 1985. He received his M. Phill degree from Sambalpur University, Orissa in 2010. Since 2010, he has been a Lecturer at the Department of Physics, Silicon Institute of Technology – Sambalpur, India. His areas of major interests are Nuclear Physics and Solid State Physics.



A. K. Akella received the Ph.D. degree in electrical engineering from Indian Institute of Technology - Roorkee in 2006. Currently, he is an Assistant Professor in the Department of Electrical Engineering at National Institute of Technology – Jamshedpur, India since 1996. His research is in the area of integrated renewable energy and energy policy.