

# Optimizing Small Wind Turbine Performance in Battery Charging Applications

Stephen Drouilhet, PE  
Eduard Muljadi, Ph. D.  
Richard Holz

*National Renewable Energy Laboratory  
Golden, Colorado*

Vahan Gevorgian, Ph. D.  
*State Engineering University of Armenia  
Yerevan, Armenia*

*Prepared for  
Windpower '95  
Washington, D.C.  
March 27-30, 1995*



National Renewable Energy Laboratory  
1617 Cole Boulevard  
Golden, Colorado 80401-3393  
A national laboratory of the U.S. Department of Energy  
Managed by Midwest Research Institute  
for the U.S. Department of Energy  
under contract No. DE-AC36-83CH10093

Prepared under Task No. WE517230

May 1995

## NOTICE

This report was prepared as an account of work sponsored by an agency of the United States government. Neither the United States government nor any agency thereof, nor any of their employees, makes any warranty, express or implied, or assumes any legal liability or responsibility for the accuracy, completeness, or usefulness of any information, apparatus, product, or process disclosed, or represents that its use would not infringe privately owned rights. Reference herein to any specific commercial product, process, or service by trade name, trademark, manufacturer, or otherwise does not necessarily constitute or imply its endorsement, recommendation, or favoring by the United States government or any agency thereof. The views and opinions of authors expressed herein do not necessarily state or reflect those of the United States government or any agency thereof.

Available to DOE and DOE contractors from:

Office of Scientific and Technical Information (OSTI)  
P.O. Box 62  
Oak Ridge, TN 37831

Prices available by calling (615) 576-8401

Available to the public from:

National Technical Information Service (NTIS)  
U.S. Department of Commerce  
5285 Port Royal Road  
Springfield, VA 22161  
(703) 487-4650



## **Optimizing Small Wind Turbine Performance in Battery Charging Applications**

Stephen Drouilhet, PE

Eduard Muljadi, Ph.D.

Richard Holz

Wind Technology Division  
National Renewable Energy Laboratory  
1617 Cole Blvd.  
Golden, Colorado 80401

Vahan Gevorgian, Ph. D.

State Engineering University of Armenia  
Yerevan, Armenia

### **INTRODUCTION**

Many small wind turbine generators (10 kW or less) consist of a variable speed rotor driving a permanent magnet synchronous generator (alternator). One application of such wind turbines is battery charging, in which the generator is connected through a rectifier to a battery bank. The wind turbine electrical interface is essentially the same whether the turbine is part of a remote power supply for telecommunications, a stand-alone residential power system, or a hybrid village power system, in short, any system in which the wind generator output is rectified and fed into a DC bus. Field experience with such applications has shown that both the peak power output and the total energy capture of the wind turbine often fall short of expectations based on rotor size and generator rating.

Other authors have discussed the performance limitations of permanent magnet wind turbine generators (WTG) in battery charging applications, which are caused by the poor match, over most of the operating wind speed range, of the rotor, generator, and load characteristics [German 1984, Lawrance et al. 1994, Seale 1983]. In this paper, we present a simple analytical model of the typical wind generator battery charging system that allows one to calculate actual power curves if the generator and rotor properties are known. The model clearly illustrates how the load characteristics affect the generator output.

In the second part of this paper, we present four approaches to maximizing energy capture from wind turbines in battery charging applications. The first of these is to determine the optimal battery bank voltage for a given WTG. The second consists of adding capacitors in series with the generator. The third approach is to place an optimizing DC/DC voltage converter between the rectifier and the battery bank. The fourth is a combination of the series capacitors and the optimizing voltage controller. We also discuss both the limitations and the potential performance gain associated with each of the four configurations.

## PART I: MODELLING THE WIND TURBINE BATTERY CHARGING SYSTEM

### Single Phase Model of the WTG Battery Charging Circuit

The typical three-phase WTG battery charging system is shown schematically in Figure 1. A rotor drives a permanent magnet synchronous generator at variable speed, depending on the wind speed. The output of the generator is rectified and fed to a battery bank. Typically there is a charge controller in the circuit to prevent overcharging of the batteries. We omitted the charge controller from the present discussion, because normally it is only active when the batteries are near a state of full charge and otherwise does not affect system performance. The primary issue we are considering is not battery-charging dynamics, but the fundamental performance of a permanent magnet generator used to charge a nearly constant voltage DC bus.

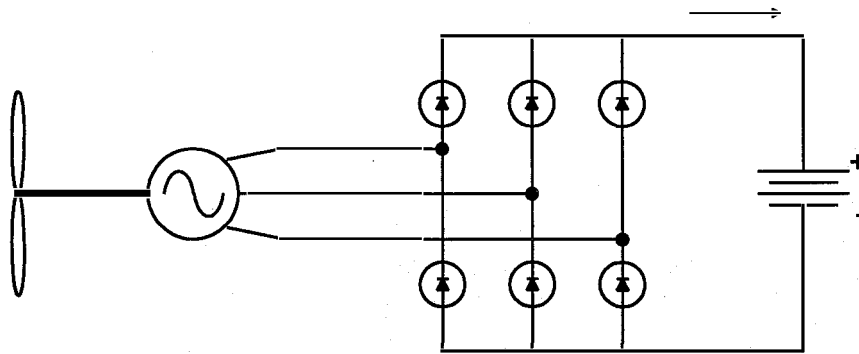

Figure 1. Typical Three-Phase WTG Battery Charging System

In a balanced three-phase circuit, all three phases are equivalent. It is therefore sufficient to model the system as a per-phase equivalent circuit. The power delivered by the actual generator is then simply three times that of the single-phase representation. As shown in Figure 2, a single-phase permanent magnet synchronous generator may be modeled as an AC voltage source in series with an inductance and a resistance. The voltage and frequency of the AC source is proportional to the rotor speed. The inductance  $L_S$  and resistance  $R_A$  are the internal inductance and resistance of the generator.

In the present context, we are interested only in the steady state behavior of the electrical system. That is, for a particular generator and battery voltage, we wish to calculate the power transferred from the generator to the battery bank as a function of generator frequency. This may be done using the classical methods of linear circuit analysis if we replace the highly non-linear rectifier/battery combination with a linear component that imposes an equivalent<sup>1</sup> load on the generator. In fact, this equivalence is

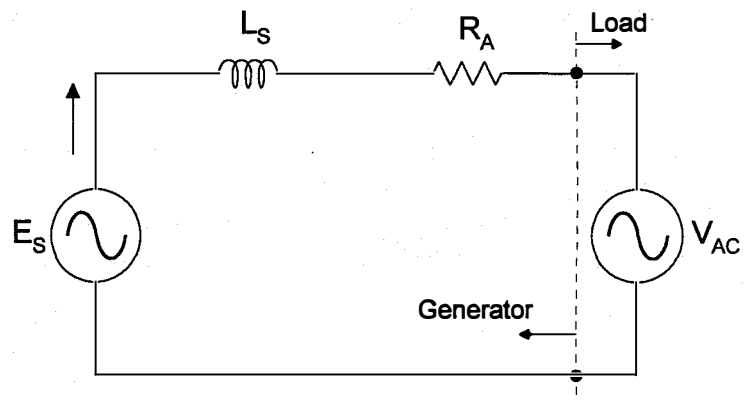
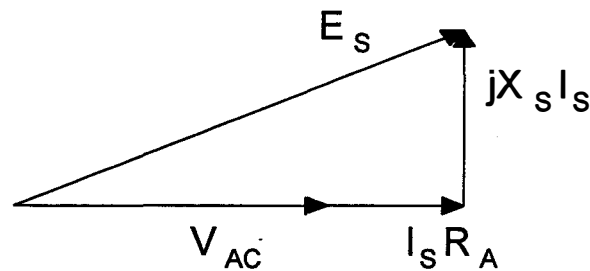

Figure 2. Single phase model of WTG Battery Charging Circuit

achieved by replacing the rectifier/battery with a sinusoidal AC voltage source as shown in Figure 2. The frequency and phase of this voltage source are both tied to that of the AC current in the circuit. The AC voltage amplitude  $V_{AC}$  is constant and represents the battery voltage referred to the AC side of the rectifier and is given by<sup>2</sup>

$$V_{AC} = \frac{\pi}{3\sqrt{6}} V_{DC}$$

The phasor diagram for the single phase circuit is shown in Figure 3.



**Figure 3.** Phasor Diagram of Per-Phase Equivalent Circuit

Through simple geometric analysis, one can solve for the stator current  $I_s$ . The generator power output is then given by

$$P_{gen,out} = 3I_s V_{AC}$$

The input power to the generator is then approximated as the output power plus the generator's internal resistive losses:

$$P_{gen,in} = P_{gen,out} + 3I_s^2 R_A$$

Figure 4 shows the output power vs. frequency calculated for a nominally 10 kW permanent magnet generator connected through a rectifier to a 240 VDC battery bank. The generator parameters  $E_s(f)$ ,  $L_s$  and  $R_A$  were determined by experiment. Note that the alternator does not begin transferring power to the battery bank until the electrical frequency (which is proportional to shaft speed) reaches about 35 Hz. At lower speeds, the generator does not produce a high enough voltage to overcome the reverse bias on the rectifier diodes imposed by the battery voltage. At higher speeds, the power out rises rapidly but then quickly rolls off at slightly more than 6 kW.

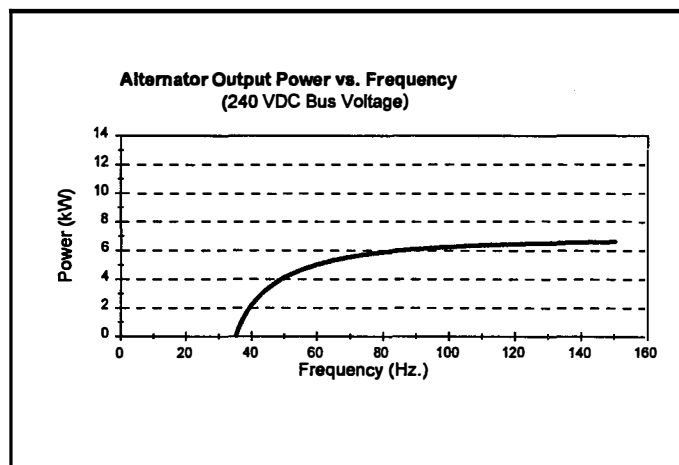

**Figure 4**

As the generator frequency increases, power transfer is limited by high resistive losses in the generator and the increasing impedance of the stator inductance  $L_S$ . Figure 4 shows the essential impedance mismatch of permanent magnet generator to a rectifier/battery load. At low frequencies, the generator is a low impedance source and the load is very high impedance (no current can flow due to the rectifier's reverse bias). At high frequencies the generator is a high impedance source, while the battery bank now has a very low impedance (small voltage changes produce large changes in current). Only at a particular frequency in the middle of the range (in this case about 50 Hz) can efficient power transfer occur.

### Determining the System Power Curve

Figure 5 shows a power coefficient versus tip speed ratio curve typical of horizontal axis wind turbine rotors. This particular rotor has a maximum  $C_p$  of about .43 occurring at a tip speed ratio of about 7. This curve was used to model the rotor performance in the present analysis. By assuming a particular rotor diameter (taken here to be 6.5 m), one can convert the  $C_p$  curve into a rotor power versus frequency curve at a given wind speed. A family of such curves is shown in Figure 6. The WTG power curve is obtained by determining the locus of intersections between this family of curves and the generator *input* power versus frequency curve, because at steady state, the power output by the rotor must be completely absorbed by the generator.

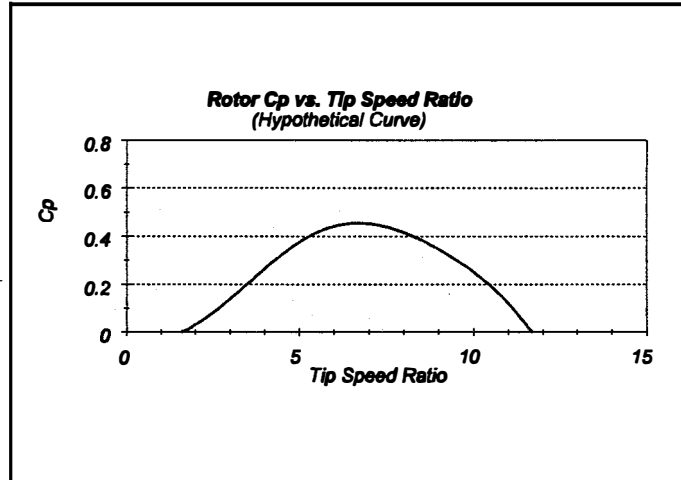

Figure 5

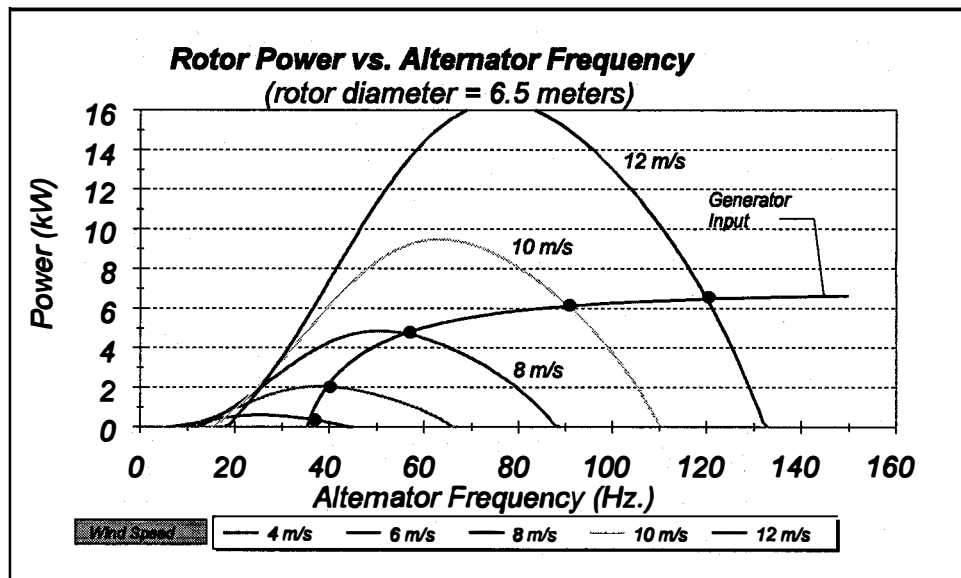

Figure 6

The WTG power curve obtained in this manner is shown in Figure 7. Also shown for reference is the maximum available rotor power, i.e., the shaft power that the rotor would produce if it operated always at

optimal tip speed ratio. Note that because of the generator characteristic shown in Figure 4, at low wind speeds the generator output goes to zero and at high wind speeds it rolls off at a little more than 6 kW. Only at wind speeds from 5 to 6 m/s is maximum power being extracted from the rotor.

Figure 8 shows the generator stator current as a function of wind speed. At higher wind speeds, the stator current approaches the generator's rated current of 24 amps even though the power output is well below the rated power of 10 kW. Generator current is one of the constraints that must be respected when developing solutions to the battery charging performance problem.

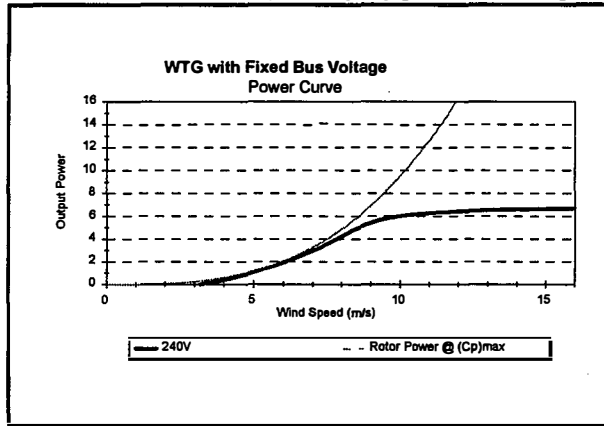

Figure 7

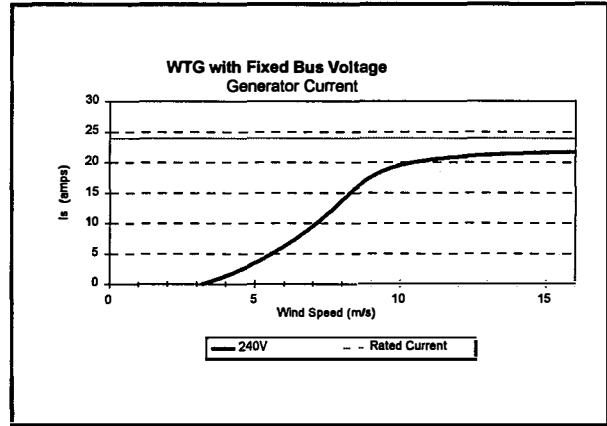

Figure 8

## PART II: EVALUATING FOUR APPROACHES TO IMPROVING SYSTEM PERFORMANCE

We considered four different approaches to improving the energy capture of small wind turbines, involving four different system configurations, ranging from the simple to the sophisticated. The four configurations are shown in Figure 9 and will be considered individually in the sections that follow.

### Optimal Fixed Bus Voltage

Configuration 1 in Figure 9 represents current practice and is the configuration we have discussed so far in this report. The first approach to performance optimization is to simply determine the fixed DC bus (battery bank) voltage that will yield the maximum annual energy capture. As shown in Figure 10, different battery voltages lead to different power curves for the same rotor/generator combination. By integrating the various power curves with the wind speed frequency distribution corresponding to a particular wind regime of interest, it is possible to

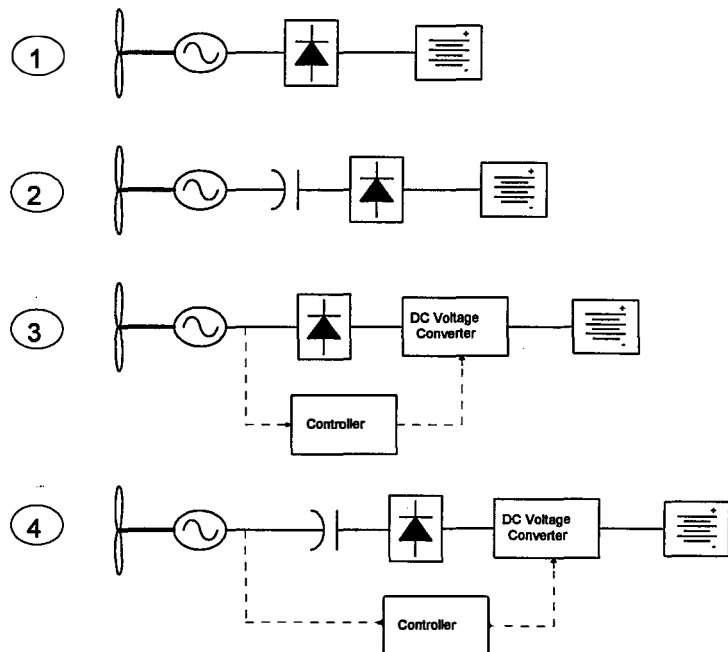

Figure 9. Wind Turbine Battery Charging Configurations

determine the battery voltage that will yield the highest energy capture. The results of such an analysis is not shown here, but it turns out for the hypothetical wind turbine analyzed here, the 240 VDC battery bank is optimal for a Rayleigh wind speed distribution with an average wind speed of 4-5 m/s. Because such moderate wind regimes are typical of the installation sites for small wind turbines, we will use the 240V performance as being representative of Configuration 1.

Unfortunately, the performance gain available by optimally choosing the battery voltage is very limited. As seen in Figure 10, when the battery bank voltage is raised to increase high wind performance, low wind performance suffers, and vice versa. The remaining three configurations attempt to address the problem by changing the impedance characteristics of the generator, the load, or both.

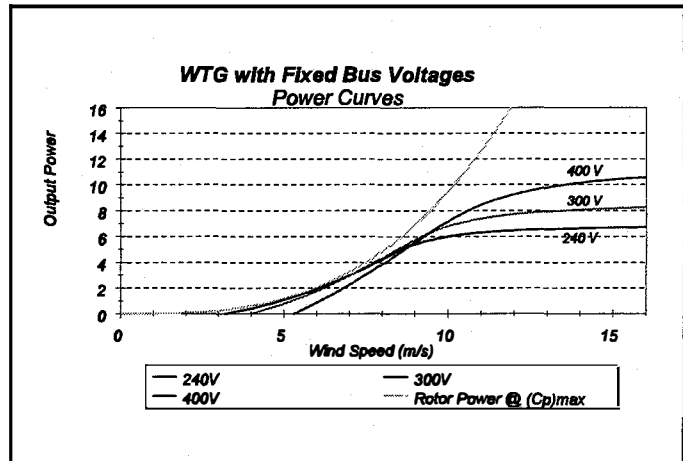

Figure 10

### Series Capacitor Configuration

Configuration 2 of Figure 9 shows the addition of a capacitor in series with the generator, which has the effect of lowering the generator's effective impedance at higher frequencies. The capacitor value is tuned so that it resonates with the inductor at a frequency at the upper end of the generator operating range. The performance of this circuit was obtained by an analysis procedure similar to that presented in Part I.

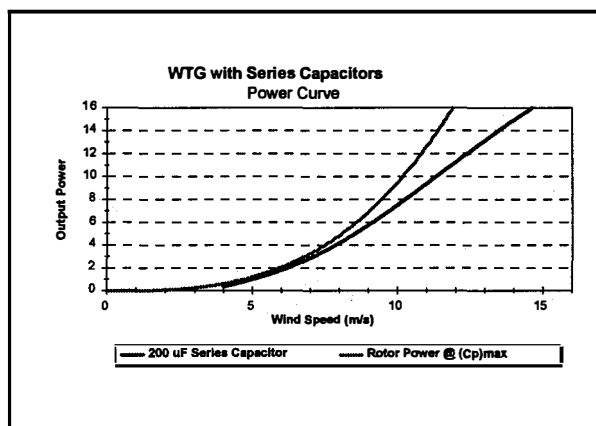

Figure 11

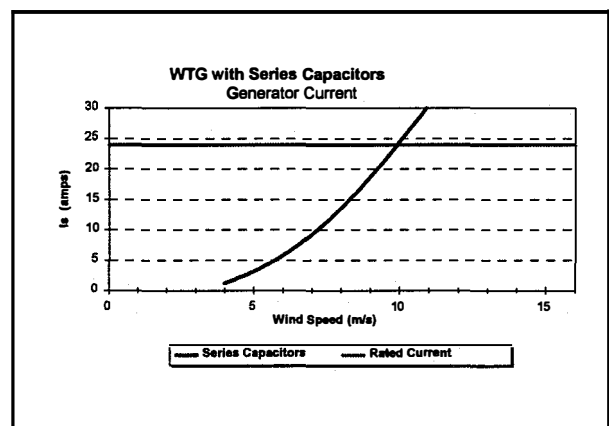

Figure 12

The WTG power curve obtained in this configuration, shown in Figure 11, is a significant improvement over Configuration 1. (The fact that power does not roll off at the rated power level is not significant here, because most small wind turbines have a furling or blade pitch mechanism to limit power output.) However, the graph of stator current versus wind speed for this case (Figure 12) shows that this is not a viable system,



because the generator current rises very rapidly with increasing wind speed and exceeds the rated value at a wind speed of less than 10 m/s, when the generator output is only 7 kW. Leaving the capacitor in the circuit at higher wind speed would damage the generator. Some other modification is required in order to keep the generator currents to an acceptable level.

### Optimizing Voltage Controller

Configuration 3 of Figure 9 shows the basic battery charging system with the addition of a DC/DC voltage converter and a controller. Because the battery bank voltage is fixed, the function of the voltage converter is to vary the DC voltage on its *input* side according to a set point provided by the controller. The converter/controller combination we refer to as an Optimizing Voltage Controller (OVC). Because the OVC is in fact regulating the rectifier output voltage, it is effectively regulating the AC voltage at the rectifier input ( $V_{AC}$  in Figure 2), and in turn the generator terminal voltage. The Optimizing Voltage Controller maintains the rectifier output voltage at the level that causes the maximum power transfer from the rotor to the battery bank.

At low wind speeds, a low voltage is applied to the rectifier output, which allows current to flow even at low generator speed. At high wind speed, a high voltage is maintained at the rectifier output, which raises the apparent impedance of the load, making it a better match to the generator. The control transfer function is actually quite complex, because the optimum power transfer depends not only on the generator and load characteristics, but also on the rotor characteristics. The details of the operation of the Optimizing Voltage Controller are not covered in this paper, only its function and the effect it has on system performance.

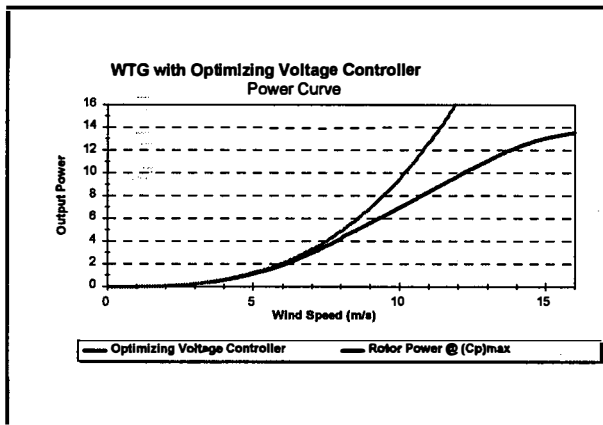

Figure 13

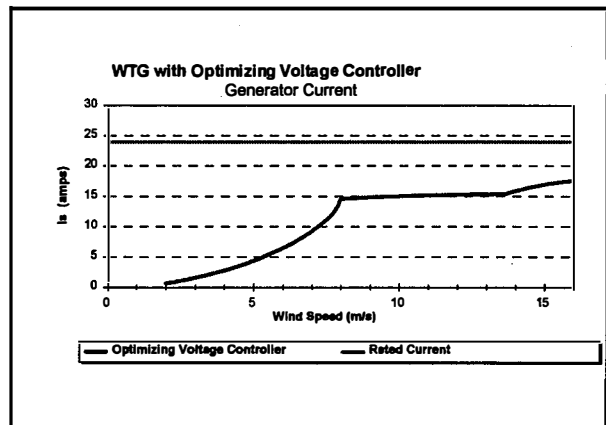

Figure 14

Figure 13 shows the system power curve obtained using the Optimizing Voltage Controller. As with the series capacitors, the power curve is a big improvement over the base case (Figure 7). The cut-in wind speed has been reduced, resulting in improved low wind energy capture. Also, the generator current is well below rated current over the whole operating range (see Figure 14). Still, at wind speeds above about 8 m/s, the power curve departs significantly from the power available in the rotor, in fact, more so than with Configuration 2. Although increasing the apparent battery bank voltage reduces the resistive losses and improves the impedance match between the generator and the load, the generator inductance still dominates as the operating frequency increases. This inductive impedance tends to limit the electric power transfer.

## Optimizing Voltage Controller with Series Capacitors

Configurations 2 and 3 both result in improved system power curves, but both configurations have limitations. The final configuration we considered was Configuration 4 shown in Figure 9, which combines the series capacitors with the Optimizing Voltage Controller. Again, the function of the OVC is to continuously maintain the rectifier output voltage at the level that results in maximum wind power conversion by the rotor. The combined configuration simultaneously achieves the current-limiting benefits of the Optimizing Voltage Controller with the generator impedance-reducing benefits of the series capacitors, resulting in a greater performance improvement than is attainable with either feature alone. The system power curve is shown in Figure 15. Note that the generator power output closely tracks the optimal rotor power curve all the way up to a wind speed of about 12 m/s. The generator current versus wind speed curve (Figure 16) is particularly interesting. The current increases steadily from zero to rated current and then goes no higher. In addition to its power optimization function, the controller algorithm is designed to limit the generator current to its rated value. When operating in this mode, the controller sets the rectifier output voltage to maximize generator power output subject to the generator current constraint. The presence of the active controller in the system offers the possibility of imposing other operating constraints as well, such as maximum allowable power output and maximum generator terminal voltage.

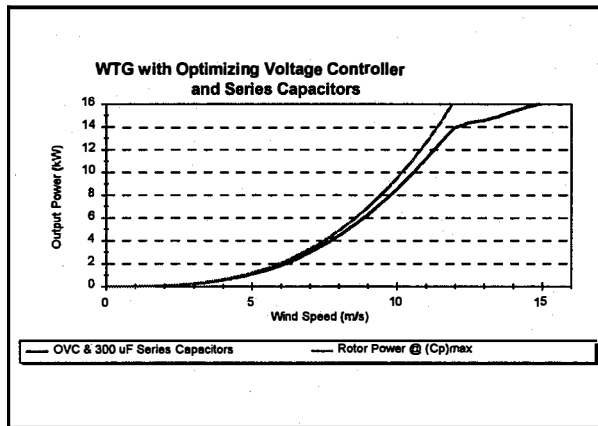

Figure 15

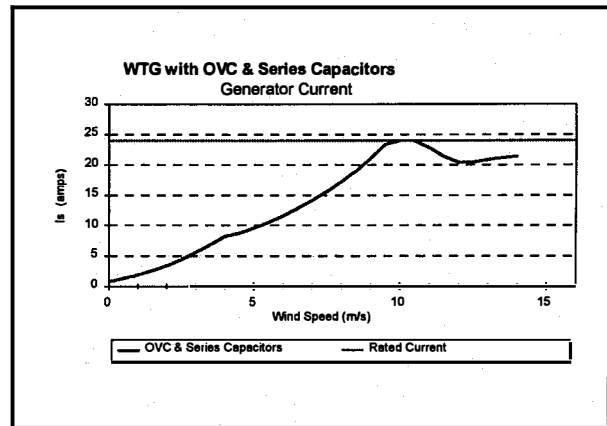

Figure 16

## Performance Comparison

The power curves for Configurations 1, 3, and 4 are shown together in Figure 17. (Configuration 2, which consists of capacitors placed in series with the generator, is omitted because of the excessive currents associated with this configuration.) As mentioned earlier, the performance shown for Configuration 1 assumes a 240 VDC battery bank. What is remarkable about these curves is that by merely adding electrical components (capacitors and a voltage controller) to

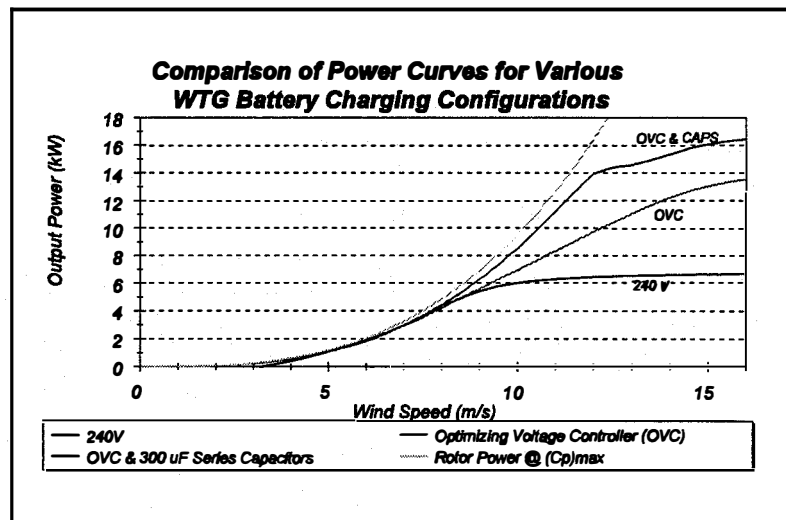

Figure 17

## CONCLUSIONS

1. The standard rectifier/battery combination is inherently poorly matched to a permanent magnet AC wind turbine generator. Both low wind and high wind performance suffer due to the impedance mismatch between the generator and the load.
2. Series capacitors improve system performance by decreasing effective generator impedance at higher wind speeds. However, series capacitors alone (Configuration 2) lead to excessive generator current.
3. An optimizing voltage controller at the rectifier output improves system performance by decreasing the effective impedance of the battery bank at low wind speeds and increasing it at high wind speeds to more closely match the generator characteristics.
4. The most promising system configuration combines series capacitors with an Optimizing Voltage Controller (Configuration 4). This system allows the generator power output to track the optimal rotor power curve over an extended range of wind speeds. The calculated increase in annual energy capture at typical sites ranges from 15 to 65%, depending on the annual average wind speed.

## FUTURE WORK

The National Renewable Energy Laboratory's Wind Technology Division plans to pursue the refinement and implementation of the proposed WTG battery charging system. The phases of the planned work are as follows:

1. Complete a dynamic analysis of the whole system, including rotor, generator, capacitors, OVC, and battery bank. Preliminary analysis indicates that the system has acceptable dynamic behavior, with no instabilities present.
2. Bench test a prototype of the Optimizing Voltage Controller on a typical permanent magnet alternator driven by a dynamometer.
3. Install and field test a complete WTG system in a battery-charging situation.
4. Work with industry partners to commercialize the technology.

## REFERENCES

German, J.C. (1984). "An Electronic Controller to Maximize Efficiency of Battery Charging from a Wind Generator", *Alternative Energy Systems - Proceedings of the Electrical Integration and Utilisation Conference, Coventry Polytechnic, Coventry, England, 10-12 September 1984*. Pergamon Press.

Lawrance, W.; Langridge, D; Johnston, D. (1994). "Low Wind Speed Wind Generation Scheme," *Renewable Energy*, Vol. 4, No. 5, pp. 489-494.

Seale, J.B. (April 1983). *Matching Wind Turbine Rotors and Loads - Computational Methods for Designers*, Rockwell International Corporation, Wind Energy Research Center, Report Number RFP-3423, Final Report under U.S. Department of Energy Contract DE-AC04-76DP03533.

## **NOTES**

1. It is important to note here that the equivalence here is limited to the average electric power transfer from the generator to the load. The actual current and voltage waveforms at the input to the rectifier are not sinusoidal and are not represented accurately by the simple model described here.
2. Our intent here is not to present our analytical method in detail but simply to describe our basic approach to modelling the wind turbine battery charging system. The derivation of the relationship between the voltage of the battery bank (or DC bus) and the voltage of the AC voltage source representation of the rectifier/battery system is described fully in a more theoretical paper to be published by Eduard Muljadi of the National Renewable Energy Laboratory in late 1995.

the base system, we have transformed a 6.5 kW peak power wind turbine generator into a 16 kW machine, even while reducing its cut-in wind speed. The substantial improvement of the power curve, particularly over the upper half of the wind speed operating range, has a profound impact on the annual energy capture of the wind turbine. Figure 18 compares the annual energy output of the wind turbine in these three configurations, assuming a Rayleigh wind speed frequency distribution. Figure 19 shows the same data represented as the percent performance gain of Configurations 3 and 4 over Configuration 1 as a function of average annual wind speed. Even at *worst*, in very moderate wind regimes with an average wind speed of about 4 m/s, Configuration 4 offers a performance gain of 15% over Configuration 1. In what would be considered good wind sites, with average wind speeds from 5.5 to 7 m/s, the increase in annual energy capture ranges from 30% to 50%. Performance gains of this magnitude will have a major impact on the economics of small wind turbines in battery charging applications.

A detailed cost analysis of the system modifications involved in Configuration 4 has not been done, but we estimate that the additional hardware cost to be less than 5% of the installed cost of the typical small wind turbine. In practice, this additional cost would likely be offset by savings associated with the substitution of a smaller generator for a given rotor size, because the capacitor/OVC combination allows one to safely extract more power from a given size generator, or conversely, the same amount of power from a smaller generator.

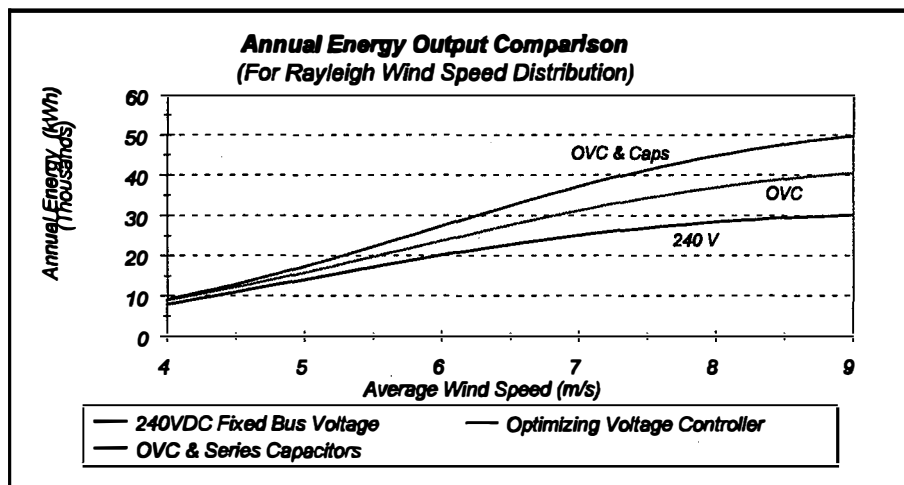

Figure 18

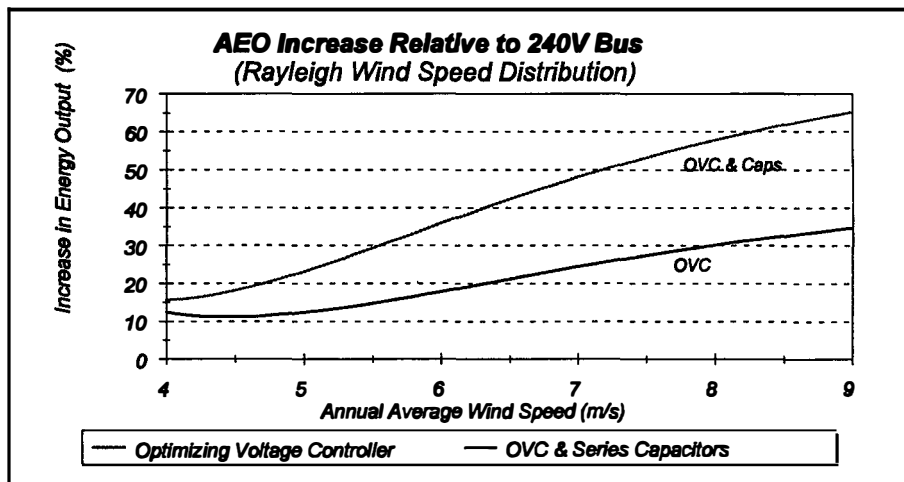

Figure 19