

Optimum Design for RF-to-Optical Up-Converter in Coherent Optical OFDM Systems

Yan Tang, William Shieh, Xingwen Yi, and Rob Evans

Abstract—In this letter, we conduct analysis on the optimum design for RF-to-optical up-converter in coherent optical OFDM systems using an optical I/Q modulator. We first derive closed-form expressions for the nonlinearity in the optical I/Q modulator, represented by two-tone intermodulation products as a function of the bias point and modulation index. Additionally, we perform a numerical simulation to identify Q -penalty and the excess modulation insertion loss under various transmitter conditions. We find that in contrast to the direct-detected system, the optimal modulator bias point for the coherent system is π , where the Q -penalty and excess loss are minimized.

Index Terms—Coherent communications, nonlinearity, optical modulator, orthogonal frequency-division multiplexing (OFDM).

I. INTRODUCTION

ORTHOGONAL frequency-division multiplexing (OFDM) has been extensively studied to combat RF microwave multipath fading [1]. Recently, an optical equivalent of RF OFDM called coherent optical OFDM (CO-OFDM) has been proposed to combat fiber dispersion [2]. In addition to its inherent chromatic dispersion tolerance, CO-OFDM provides a potential to resolve the impairment from fiber polarization-mode dispersion [3]. In a CO-OFDM system, optical Mach-Zehnder modulators (MZMs) are used to up-convert the OFDM signal from the RF domain to optical domain and coherent balanced receivers to down-convert the OFDM signal from optical domain to the RF domain. The MZM characteristic has been intensively investigated in [4]. It is also well known that OFDM is very sensitive to nonlinearity, and subsequently a thorough study of the nonlinearity impact from the up-converter on CO-OFDM systems is of great interest. In this letter, we focus on the up-converter nonlinearity introduced by the nonlinearity of MZM.

The nonlinearity of MZM on the system performance in the direct-detected systems has been extensively studied in [5] and [6]. It is shown that for the conventional direct-detected system the optimal bias point is at quadrature and a large signal will add

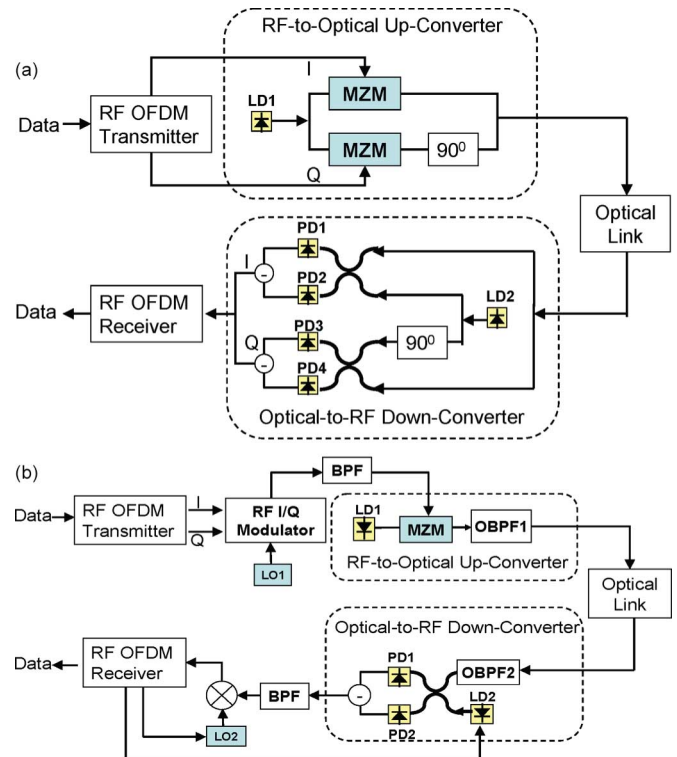

Fig. 1. CO-OFDM system with (a) direct up/down conversion architecture and (b) IF architecture.

nonlinearity impairment to the system. In this letter, we conduct analysis on the optimum design for a CO-OFDM up-converter using an optical I/Q modulator. We first derive closed-form expressions for the nonlinearity in the optical I/Q modulator, represented by two-tone intermodulation products as a function of the bias point and modulation index. Additionally, we perform a numerical simulation to identify the excess modulation insertion loss and Q -penalty from nonlinearity for the CO-OFDM system.

II. CO-OFDM SYSTEM ARCHITECTURE

Figs. 1(a) and (b) show, respectively, a CO-OFDM system which uses direct up/down conversion architecture and intermediate frequency (IF) architecture. The functionalities of the RF OFDM transmitter which appears in both architectures include 1) mapping the data into OFDM symbols, performing inverse-fast Fourier transform of the signal from the frequency domain to the time domain, 2) inserting pilot symbols and guard interval for receiver processing, 3) performing digital-analog-conversion to generate real-time signal.

Manuscript received November 27, 2006; revised January 24, 2007.

Y. Tang, X. Yi, and R. Evans are with Victoria Research Laboratory, National ICT Australia, Department of Electrical and Electronic Engineering, University of Melbourne, Melbourne, VIC 3010, Australia (e-mail: y.tang@ee.unomelb.edu.au; x.yi@ee.unomelb.edu.au; r.evans@ee.unomelb.edu.au).

W. Shieh is with ARC Special Research Centre for Ultra-Broadband Information Networks, Department of Electrical and Electronic Engineering, University of Melbourne, Melbourne, VIC 3010, Australia (e-mail: w.shieh@ee.unomelb.edu.au).

Color versions of one or more of the figures in this letter are available online at <http://ieeexplore.ieee.org>.

Digital Object Identifier 10.1109/LPT.2007.893582

In the direct up/down conversion architecture, the baseband OFDM signal $S_B(t)$ can be written as

$$S_B(t) = \sum_{k=-(N_{sc}/2)+1}^{k=N_{sc}/2} C_k \exp(j2\pi f_k t), \quad f_k = (k-1)/t_s \quad (1)$$

where N_{sc} is the number of subcarriers, t_s is the OFDM symbol period, C_k is the K_{th} subcarrier that can be either information symbol or pilot symbol, and f_k is the frequency of the subcarrier. For the sake of simplicity, the OFDM signal in (1) only shows one OFDM frame. The OFDM RF-to-optical up-converter uses an optical I/Q modulator which comprises two MZMs to up-convert the real/imaginary parts of the $S_B(t)$ from the RF domain to the optical domain, i.e., each MZM is respectively driven by the real or imaginary part of the $S_B(t)$. The OFDM optical-to-RF down-converter uses two pairs of balanced receivers to perform I/Q detection optically. The RF OFDM receiver performs OFDM baseband processing and demodulation to recover the data. The direct-conversion architecture in Fig. 1(a) eliminates a need for narrow optical bandpass filters (OBPF) in both transmitter and receiver.

In the IF architecture, the OFDM baseband signal is first up-converted to an IF f_{LO1} and the OFDM IF signal after the RF I/Q modulator can be written as

$$S_{IF}(t) = \exp(j2\pi f_{LO1} t) \cdot \sum_{k=1-N_{sc}/2}^{k=N_{sc}/2} C_k \exp(j2\pi f_k t), \quad f_k = (k-1)/t_s. \quad (2)$$

The real part of the $S_{IF}(t)$ is further up-converted to optical domain with one MZM. At the receiver, the optical OFDM signal is first down-converted to an IF f_{LO2} and the I/Q detection is performed electrically.

III. TWO-TONE INTERMODULATION ANALYSIS

A two-tone intermodulation analysis is used to study the MZM nonlinearity impact on the CO-OFDM system. For the direct up/down conversion architecture Fig. 1(a), two complex subcarrier tones at $v_1 = v \cdot e^{j\omega_1 t}$ and $v_2 = v \cdot e^{j\omega_2 t}$ are applied to the input of the optical I/Q modulator. For the sake of simplicity, we only show the nonlinearity performance analysis for direct up/down conversion architecture.

The optical signal at the output of the RF-to-optical up-converter is

$$E(t) = A \cdot \cos\left(\frac{\pi}{2} \cdot \frac{V_I + V_{DC}}{V_\pi}\right) \cdot \exp(j\omega_{LD1} t) + A \cdot \cos\left(\frac{\pi}{2} \cdot \frac{V_Q + V_{DC}}{V_\pi}\right) \exp(j\omega_{LD1} t + \pi/2) \quad (3)$$

where A is a proportionality constant. All the proportionality constants will be omitted in the remainder of the letter. V_I and V_Q are real and imaginary part of the complex RF drive signal to each MZM, expressed as $V_I = v \cdot (\cos\omega_1 t + \cos\omega_2 t)$,

$V_Q = v \cdot (\sin\omega_1 t + \sin\omega_2 t)$, where V_{DC} is the DC bias voltage of the modulator, V_π is the half-wave switching voltage, ω_{LD1} is the modulator laser carrier frequency. It can be shown that the photocurrent at the output of two balanced receivers can be written as

$$I_I(t) = \cos\left(\frac{\pi}{2} \cdot \frac{V_I + V_{DC}}{V_\pi}\right), \quad I_Q(t) = \cos\left(\frac{\pi}{2} \cdot \frac{V_Q + V_{DC}}{V_\pi}\right). \quad (4)$$

The signal feeding the RF OFDM receiver in Fig. 1(a) becomes

$$S(t) = \cos\left[\frac{M}{2}(\cos\omega_1 t + \cos\omega_2 t) + \frac{\phi}{2}\right] + j \cos\left[\frac{M}{2}(\sin\omega_1 t + \sin\omega_2 t) + \frac{\phi}{2}\right] \quad (5)$$

where $M = v\pi/V_\pi$ is defined as the modulation index, $v = \sqrt{2}v_{RMS}$, and $\phi = V_{DC}\pi/V_\pi$ is the static phase shift (bias point). The so-defined modulation index M equals the optical modulation index of the optical signal if the optical modulator is biased at quadrature in a direct-detected system. Expanding the cosine term in (5) using Bessel functions, the fundamental output component with frequency $\omega_{1,2}$ can be expressed as

$$S_{\omega_{1,2}}(t) = 2 \cdot \sin(\phi/2) \cdot J_0(M/2) \cdot J_1(M/2) \cdot e^{j\omega_{1,2} t}. \quad (6)$$

The second-order intermodulation output with frequency $\omega_{1,2} - \omega_{2,1}$ can be expressed as

$$S_{\omega_{1,2}-\omega_{2,1}}(t) = 2 \cdot \cos(\phi/2) \cdot J_1^2(M/2) \cdot e^{j(\omega_{1,2}-\omega_{2,1})t}. \quad (7)$$

The third-order intermodulation output with frequency $2\omega_{1,2} - \omega_{2,1}$ will be

$$S_{2\omega_{1,2}-\omega_{2,1}}(t) = 2 \cdot \sin(\phi/2) \cdot J_1(M/2) \cdot J_2(M/2) \cdot e^{j(2\omega_{1,2}-\omega_{2,1})t}. \quad (8)$$

We employ the standard N th-order intercept point (IPN) to characterize the modulator nonlinearity [5]. In particular, IP2 (IP3) is the point where the linear extension of the second-order (third-order) intermodulation output power intersects the linear extension of the fundamental output power. The intercept points are given in terms of fundamental output power. IP2 and IP3 are calculated from (6)–(8), and can be expressed as

$$\text{IP2} = 2 \cdot \sin^4(\phi/2) / \cos^2(\phi/2) \quad (9)$$

$$\text{IP3} = 4 \cdot \sin^2(\phi/2). \quad (10)$$

It can be shown that (10) is also valid for the IF architecture, and the second-order nonlinearity is avoided for the IF architecture.

Equation (10) shows that when the modulator is biased at the zero output ($\phi = \pi$), the IP3 has the maximum value, or least nonlinearity, which means the optimum bias point should be π . Figs. 2(a) and (b) show the characteristics of the first-, second-, and third-order intermodulation as a function of the modulation index M for a bias point of π and quadrature, respectively. It can be seen that at the bias point of π , the fundamental output is maximized while the second-order intermodulation product is eliminated in comparison with the quadrature bias point.

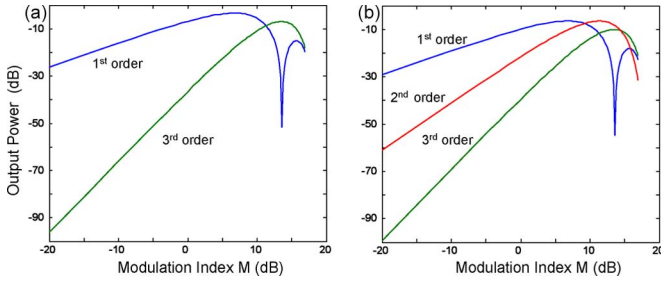

Fig. 2. First-, second-, and third-order output powers as a function of modulation index M (dB) = $20\log M$ at the bias points of (a) π and (b) $\pi/2$.

IV. SIMULATION ANALYSIS FOR OFDM OPTICAL TRANSMITTER

In order to identify the bias point impact on the CO-OFDM system, the Monte Carlo simulation is used to investigate the excess modulation insertion loss L_{EX} (dB) and the Q -penalty of the OFDM RF-to-optical up-converter under different bias points. The modulator excess modulation insertion loss is defined as

$$L_{EX} = P_{in} - P_{out} - 3 \quad (11)$$

where P_{in} (dBm) is the input optical power and P_{out} (dBm) is the optical power in OFDM band at the output of the optical I/Q modulator. The modulator excess modulation insertion loss is defined in a way such that it equals zero for a conventional MZM biased at quadrature ignoring the physical loss of the modulator.

The relevant OFDM system parameters used in the simulation are as follows: OFDM symbol period t_s of 25.6 ns, number of subcarriers N_{sc} of 256, and guard interval of 1/8 of the number of subcarriers; the BPSK encoding is used resulting in a bit rate of 10 Gb/s. We use the data-assisted method instead of pilot symbols for phase estimation. Linewidth for the two laser sources is assumed to be 100 kHz. The optical amplified spontaneous emission (ASE) noise is modeled as white Gaussian noise. The laser phase noise is assumed to be white frequency noise. Our simulation is conducted at an optical signal-to-noise ratio (OSNR) of 3.5 dB (0.1-nm ASE noise resolution bandwidth), which gives a baseline Q -value of 9.8 dB, or a bit-error rate of 10^{-3} [2] without up-converter nonlinearity. Q -penalty is defined as the Q -reduction from this reference Q -value of 9.8 dB due to up-converter nonlinearity. Figs. 3(a) and (b), respectively, show the Q -penalty and excess modulation insertion loss as a function of modulation index, at a fixed OSNR of 3.5 dB while varying the bias point. Insets in Fig. 3 show the OFDM spectrum at various bias points and modulation indexes. For the bias points of $\pi/2$ or $\pi/4$, at the lower modulation index, the residual optical carrier takes a large portion of the signal power and does not contribute to the signal strength in the CO-OFDM systems, and subsequently severely increases the Q -penalty. It can be seen that not only the bias point of π provides the least Q -penalty [Fig. 3(a)], but also it incurs the least excess loss [Fig. 3(b)]. In particular at a modulation index M of 0.6 (1.6), the Q -penalty is about 0.2 dB (1 dB) and the

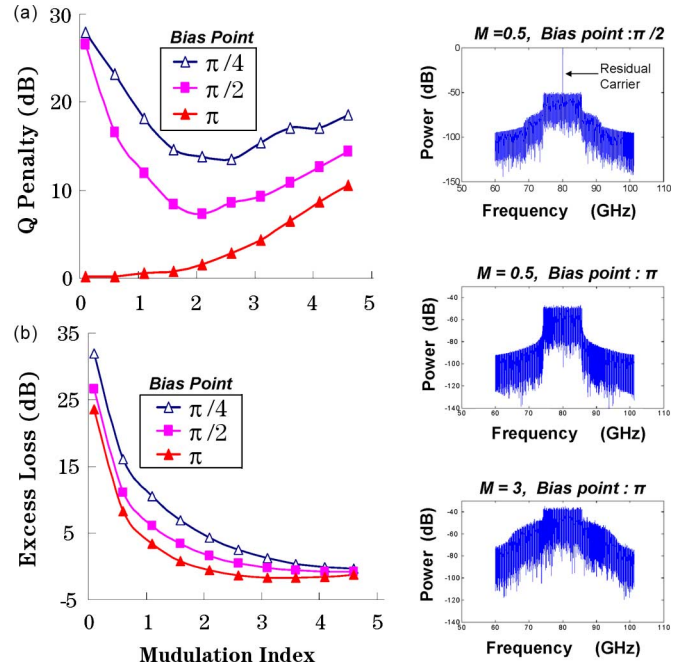

Fig. 3. (a) Q -penalty and (b) excess loss as a function of modulation index, M with varying bias point. Q -penalty is computed at an OSNR of 3.5 dB.

insertion loss is about 8 dB (1 dB), for the bias point at π . Insets in Fig. 3(b) show the OFDM spectra with a modulation index of 0.5 and 3, respectively, at the bias point of π . It can be seen that a large modulation index introduces more intermodulation products as evidenced by the appearance of significant spectral components outside of the OFDM band.

V. CONCLUSION

In this letter, the optical I/Q modulator nonlinearity in CO-OFDM system based on direct up/down conversion has been analyzed. The theoretical analysis and numerical simulation results obtained in this letter show that at the optimum operation bias point of π for MZM, the OFDM signal incurs minimal excess modulation insertion loss and Q -penalty from nonlinearity.

REFERENCES

- [1] S. Hara and R. Prasad, *Multicarrier Techniques for 4G Mobile Communications*. Boston, MA: Artech House, 2003.
- [2] W. Shieh and C. Athaudage, "Coherent optical orthogonal frequency division multiplexing," *Electron. Lett.*, vol. 42, pp. 587–589, 2006.
- [3] W. Shieh, W. Chen, and R. S. Tucker, "Polarization mode dispersion mitigation in coherent optical orthogonal frequency division multiplexed systems," *Electron. Lett.*, vol. 42, pp. 996–997, 2006.
- [4] F. Auracher and R. Keil, "Method for measuring the RF modulation characteristics of Mach-Zehnder-type modulators," *Appl. Phys. Lett.*, vol. 36, pp. 626–629, 1980.
- [5] B. H. Kolner and D. W. Dolfi, "Intermodulation distortion and compression in an integrated electrooptic modulator," *Appl. Opt.*, vol. 26, no. 17, p. 3676, Sep. 1987.
- [6] M. Mayrock and H. Haunstein, "Impact of implementation impairments on the performance of an optical OFDM transmission system," presented at the Tech. Dig. ECOC 2006, Cannes, France, Paper Th3.2.1.