

ORCA-VII: An Autonomous Underwater Vehicle



*Robert C. Altshuler, Joshua F. Apgar, Jonathan S. Edelson, David L. Greenspan,
Debra E. Horng, Alex Khripin, Ara N. Knaian, Steven D. Lovell,
Seth O. Newburg, Jordan J. McRae, Marvin B. Shieh*

Massachusetts Institute of Technology
Project ORCA
77 Massachusetts Avenue, Room 4-405
Cambridge, MA 02139

<http://web.mit.edu/orca/www>

The ORCA-VII is a fully autonomous submarine built to compete in the 2004 International AUV competition. The ORCA-VII is 48" long, 28" wide, and approximately 45 kg. The vehicle is propelled by a pair of horizontal thrusters mounted on the sides and a pair of vertical thrusters on the bow and stern. Autonomous navigation is aided by a suite of instruments including a water pressure depth sensor, a fluid-bulb inclinometer, a DSP based sonar direction finder, a magnetic compass, an inertial measurement unit, a light source tracker and an underwater video camera with computer vision software.

The ORCA-VII follows the basic modular design philosophy of previous incarnations of ORCA. The mechanical frame and core systems are mostly unchanged from the 2003 entry allowing development efforts to be concentrated on redesigning some of the systems, such as the motor controllers, for increased performance and reliability. A custom MEMs-based inertial measurement unit has been developed and an off the shelf camera system is used detecting and targeting the optical beacon provided in the competition arena.

Introduction

ORCA-VII is designed according to the guidelines of the 7th International Autonomous Underwater Vehicle Competition. The competition arena is located at the SPAWAR TRANSDEC facility in San Diego, California. The arena is an oval 200' wide and 320' long, with a flat bottom 16' deep. There is a 160' diameter semi-spherical depression in the middle that extends to a 38' depth at its center.

In the competition arena there will be a validation gate, a linear array of five target bins with an illuminated beacon marking them, and a recovery zone marked by an acoustic beacon.

The competing vehicles will have 15 minutes to complete the mission. Each vehicle must demonstrate basic operation by passing through the validation gate before attempting any other portion of the course. The vehicle then proceeds to the target bins where it must autonomously detect the bins and drop markers in them to score points. After marking the bins, the vehicles will demonstrate an autonomous recovery maneuver by navigating to the recovery zone and surfacing.

ORCA-VII was built to complete this mission reliably, repeatedly, and safely. The modularity of design allowed easy testing and modification throughout the process of construction. All of the modules were tested to insure safe operation.

Structural Overview

The hull of ORCA-VII has a single watertight compartment to house the computer and most of the electronics. The batteries and sensors are mounted on the aluminum frame in an open sensor bay

below the tube. Two vertical thrusters, mounted at the bow and stern, control the vehicle's depth and pitch. Two horizontal thrusters at the sides control the forward velocity and heading of the submarine.

The vehicle is controlled by a single board computer running Linux. A spread-spectrum radio data link or an Ethernet tether may be used to communicate with the submarine computer.

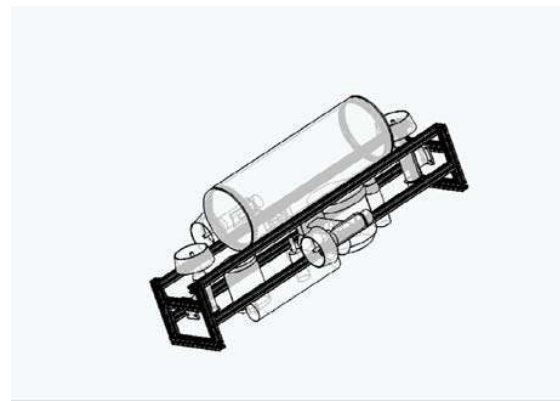

Wire frame drawing of ORCA-VII

The ORCA-VI controls its depth using feedback from a pressure sensor or sonar altimeter. Heading is controlled using feedback from a magnetic compass. The submarine can navigate in relation to an acoustic beacon with its four hydrophones. To recognize the visual cues and aim for the target, ORCA-VI uses a video camera and machine vision software.

Mechanical and Electrical Systems

The mechanical design of ORCA-VII is meant to be simple and modular. The frame was divided into four larger mechanical parts that could be constructed separately: the skeleton, the thruster mounts, the waterproof housing, and the sensor mounts.

The skeleton is made of 80/20 10-series T-slotted aluminum extrusions. Modifications can easily be made to the simple rectangular

design. The slotted extrusions allow all of the components to slide into place for easy mounting and vehicle trimming.

Each thruster mount is made of three aluminum pieces, welded together. One rectangular block attaches the mount to the 80/20 frame. A streamlined foil holds the thrusters away from the vehicle, without adding significant drag or blocking flow. A motor mount allows the cylindrical thruster body to be hose-clamped firmly to the end of the mount.

The single dry compartment is a 27-inch long, eight-inch diameter PVC pipe. The hull is mounted on the aluminum frame and closed with PVC end plugs with double O-ring bore seals. Through-hull electrical connections are made with bulkhead connectors mounted into these end plugs. This compartment holds the computer, radio transceiver, antenna, motor drivers, and power electronics. The electronics are mounted on guide rails supported by parallel discs that slide inside the compartment. This assembly slides in and out of the dry compartment on Teflon rods used to prevent the discs from scraping the hull. This design allows maximum use of the volume of the compartment. The sliding electronics assembly can be removed without disconnecting any cables because a blind-mating multi-pin connector links the last disk to the compartment's PVC end plug.

The sensors and batteries are mounted directly on the aluminum frame. This versatile design allows quick changing of the batteries. The batteries are placed low on the vehicle, to increase its righting moment, making the ORCA-VII passively stable in pitch and roll.

Thrusters

ORCA-VII uses four maneuvering thrusters, attached via their mounts onto the aluminum frame. Two horizontal thrusters drive the vehicle forward and back and allow control of the vehicle's yaw. Two vertically mounted thrusters allow control of depth and pitch. The thruster assemblies are provided by Inuktun Services Limited. Each one draws 7 A at 24 V producing approximately 15 lbs of thrust.

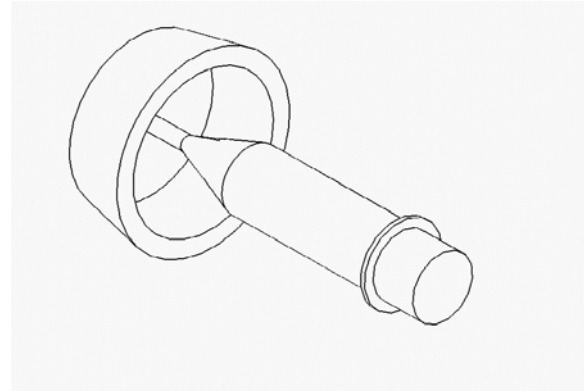

Wire frame drawing of Inuktun thruster

The Inuktun thrusters provide significantly better performance than the trolling motors used previously for horizontal thrusters. They provide almost twice the thrust that the trolling motors did at a given power level. Their higher operating voltage means they require less current than a 12 V motor, which simplifies electronics layout inside the sub. Their light weight, 2.5 lbs, provides 6 lbs of weight savings (per motor) over the trolling motors.

Motor Control

The motor controllers used in the vehicle have been completely redesigned from previous competitions. The speed controllers used in ORCA VII are derived from the 'OSMC' controller design (Open Source Motor Controller, <http://groups.yahoo.com/group/osmc/>), modified for the tight space requirements

and lower current requirements of the vehicle.

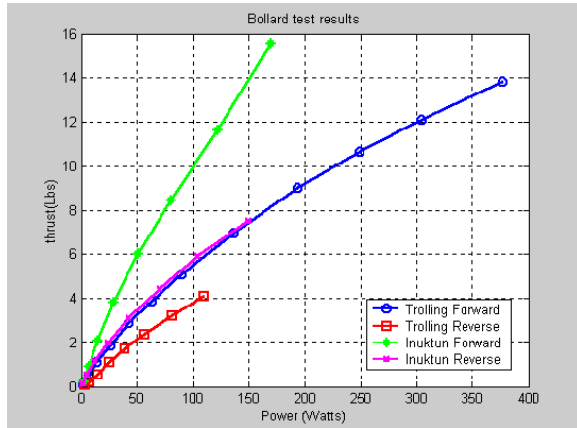

Plot of power in versus bollard thrust out for the Inuktun thrusters and the trolling motors previously used

The OSMC is a simple and robust H bridge amplifier capable of operating over a wide input voltage range and at rather high currents. An H-bridge has 4 switched legs, and the OSMC uses 4 MOSFET devices in parallel for each leg. An HIP4081 driver chip provides gate drive for all of these MOSFETS, providing the necessary high gate voltage to drive the devices into saturation, and providing the ‘high side’ gate drive voltages by means of a floating capacitor supply. Various protection components, including TVS diodes and Zener diodes are used to protect the components from possible motor transients. The 12V power supply for the fan, the HIP4081, and other components is provided by a DC-DC converter from the main DC supply voltage. The OSMC is an H-bridge alone, and does not accept standard control inputs, but rather accepts inputs directly to the HIP4081, using the HIP4081 truth table. Our new motor controllers extend the OSMC, adding a microcontroller that controls the OSMC and communicates to the computer through a serial port.

The new controllers have proven suitable and reliable. Using these new controllers, ORCA-VII is much more easily controlled. When the same thrust value is commanded to both left and right thruster, the vehicle essentially drives straight. This clean open loop performance reduces the load on feedback control loops, and releases control overhead to actually run the mission.

Electrical Connections

Electrical connections through the hull are made with hermetically sealed locking multi-pin connectors. The connectors are rated to a depth of 80 m. Each outboard component connects to the vehicle using its own receptacle mounted in the PVC end plug at the stern end of the electronics compartment. In addition to the outboard component connectors, there is a tether connector for development and testing.

Wire frame drawing of endcap machined for through hull connectors

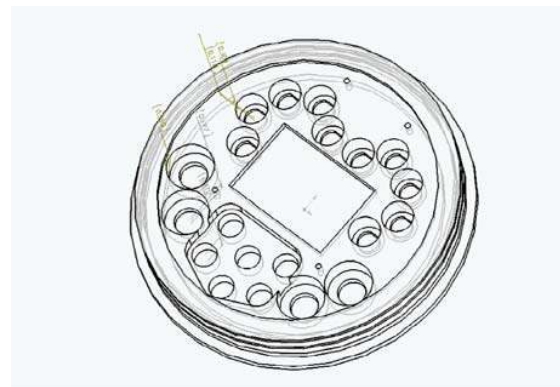

Wire frame drawing of endcap machined for through hull connectors

PCBs

ORCA-VI uses custom printed circuit boards extensively. These allow the use of small surface mount components, simplify wiring, and make for a neater, more robust submarine.

Power Supply

Two separate voltage busses power ORCA VII – one for the motors and motor drivers, another for the computer, electronics and sensors. Devices on these busses are individually fused to prevent an isolated failure from bringing the whole system down. Efficient boost and step down converters provide all voltages other than the battery voltages.

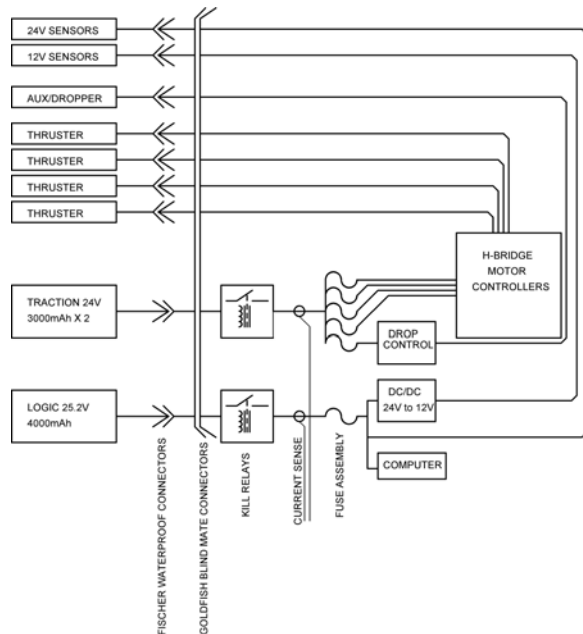

Vehicle power distribution

Power from the batteries is switched through a set of mechanical relays. Two waterproof magnetic kill switches with colored ripcords can be used to power down the motors or the computer.

The batteries are sealed in external battery pods that attach to the vehicle via through hull connectors. The electronics battery pods have 20 NiMH 4/3A cells wired in series giving a nominal voltage of 24 V and a capacity of 4 Ah. A single electronics battery pod powers the vehicle for four hours on a single charge. The motor battery pods have 20 NiMH SCU3300 cells wired in series giving a nominal voltage of 24V and a

capacity of 3.3 Ah. A pair of motor battery pods powers the motors for a half hour to an hour depending on use.

The use of external battery pods has the advantage of allowing the batteries to be changed much more quickly than if they were housed in the dry-hull.

Monitoring System

The vehicle is equipped with a power monitoring system. The voltage and current through the batteries and motors are read, and a PIC microcontroller reports values to the computer using a RS-232 serial interface. The monitoring system also has a temperature sensor to alert the operator to over temperature conditions. Blown fuses are signaled with LEDs for fast identification.

Imaging - Vision Algorithm

The goal of the vision system is to capture and analyze images of the pond bottom and determine the existence, position, and orientation of any rectangular bins the vehicle passes over.

The ORCA VII is equipped with a color video CCD camera (Aurora, Insite Tritech Inc., Solana Beach, CA). Images from the downward-pointing camera are captured using a PC/104+ frame grabber card (Sensoray 311, Sensoray Company Inc., Tigard, OR) and are saved on the computer's hard drive. Machine vision algorithms running on the main computer analyze the images and provide real-time targeting information to higher-level control programs.

The image is first transformed from its original colorspace and resolution into a grayscale raster consisting of a more manageable number of pixels. The colorspace transformation is chosen to

emphasize the white six-inch rims around the bins. The edges of this white region, especially those that bound the dark bin interiors, are likely to be the sharpest, straightest, and generally most significant

Filters are first applied to the source image (a) to determine the x and y directional derivatives of the image considered as an intensity function of x and y. The filters are convolution kernels calculated by taking the x- and y-derivatives of a two-dimensional Gaussian. The kernels are x-y separable, meaning that each can be applied using a series of two one-dimensional convolutions (for a speed boost), and they are steerable, meaning that they are a basis for a set of directional derivative filters for all directions that can be obtained by linear combination. The results of applying the two derivative filters are two signed rasters (b) holding the derivatives for each pixel. Together they define a gradient vector for each pixel.

Plotting these gradients (c) clearly reveals the dominant orientation of the edges in the image. The software detects this orientation by combining the vectors using two orthogonal quarter-turn symmetric weighting functions. Using this new information, the x- and y-derivative rasters

edges in the image. Furthermore, they are all mutually parallel or perpendicular, so that once an overall axis orientation is chosen, only two edge orientations (parallel to the two axes) are of interest. can be combined to yield two new orthogonal directional derivative rasters (d), this time specifically emphasizing edges in line with the detected orientation. The next step is to detect the individual locations of the strongest edges, and for simplicity the software works with mathematical lines rather than segments. Since only a single line orientation is of interest for each raster, the rasters can be collapsed along this direction into one-dimensional functions (e). The most prominent extrema of these functions (found by looking for zero-crossings of their derivatives) are recorded as edge-line candidates (f, red and blue).

It then remains to consider combinations of these lines as possibly bounding bin interiors. A proper set of four edges must obey many constraints, including edge sign (opposite edges must have opposite sign), bin size (compared to expectations based on the ORCA's other sensors), bin aspect ratio, gradients across the edges, and brightness and consistency of the bin-interior region of the image. Bin candidates are identified and

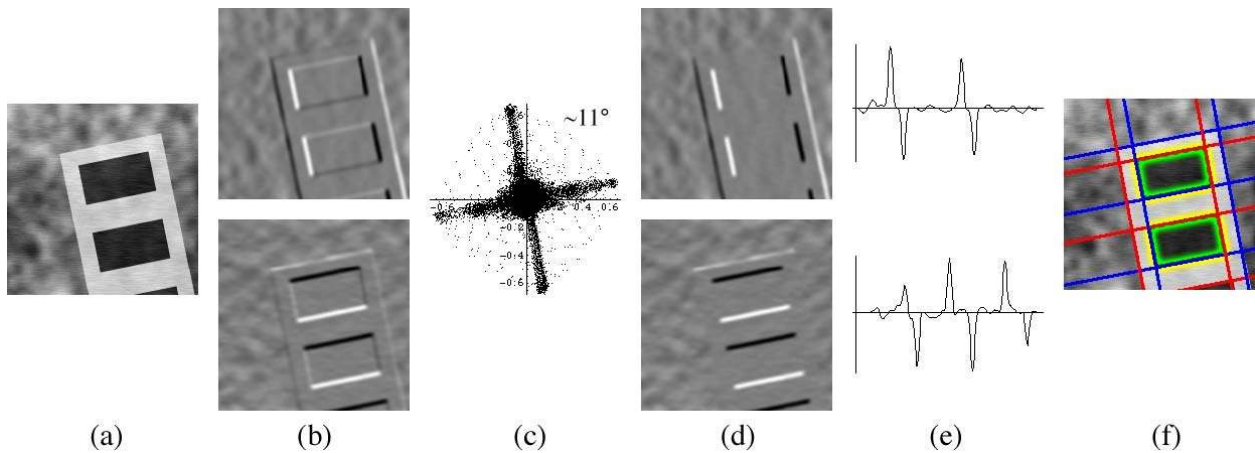

Example diagram of the machine vision algorithm

ranked using a confidence measure based on these criteria, and likely bins are reported.

Sonar Range Finders

ORCA-VII uses two Tritech PA500 sonar range finders. One is used to measure the distance to the floor of the arena. The other is mounted on the starboard side and measures the distance to the sidewall for collision avoidance. The PA500 measures the distance to the bottom by actively pinging at 500 kHz and measuring the time delay to the echo return. It returns the measured distance over an RS-232 serial port. The units are operable from 0.1 to 10 m distance, suitable for the size of the competition arena.

Depth Sensor

A Sensotec TJE series analog output pressure sensor measures the depth of the vehicle. A PIC microcontroller provides analog to digital conversion and communications to the main computer.

Doppler Velocity Log (DVL) -- Removed

In order to help meet the new weight restrictions of the competition, the Doppler Velocity Log system has been removed from the vehicle. This sensor was deemed an unnecessary payload as its measurements will not be needed for motion control or high level navigation in the proposed mission and testing environment.

Passive Sonar System

The ORCA-VII includes a passive sonar system to determine the bearings to the acoustic beacons on the targets. The passive sonar unit is mounted to the 80/20 frame with a neoprene cover for acoustic decoupling from the frame.

The system detects pings using four hydrophones mounted in a pyramidal array.

The hydrophones are mounted to the bottom of a waterproof enclosure, which contains processing electronics. The passive sonar system communicates with the ORCA-VII main computer using an RS-232 serial port. For each ping received, the unit transmits the bearing and elevation angle to the transmitter in degrees, the frequency of the ping, and the time in milliseconds since the last ping.

The system computes the angle to the pinger by measuring the time delay between the ping signal as received at each of the four hydrophones. The data acquisition and embedded computing hardware used are described in detail in the ORCA journal paper written for the 2002 AUVSI competition. Each hydrophone signal is digitized and input to a DSP microcomputer. The DSP bandpass filters and thresholds the signal from one hydrophone to find the start of each ping. The system captures the next 2 ms of signal from each hydrophone for further processing.

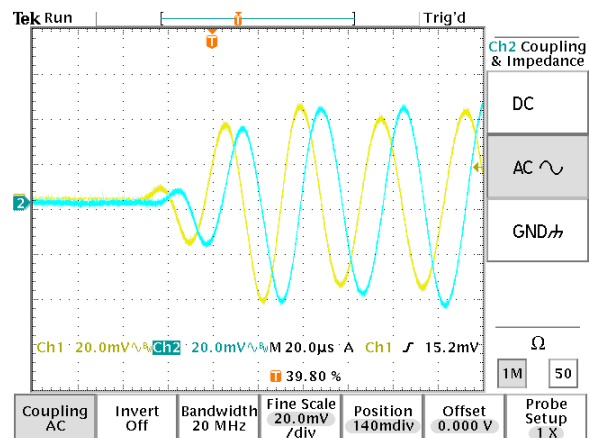

Signals from a two element array showing the angle dependent phase delay

To determine the ping frequency, the system calculates a 2048-point FFT of one of the signals, and finds the maximum energy bin. The system then determines the time delay between each pairwise combination of

hydrophones, using the method of generalized cross-correlation as described in Underwater Signal and Data Processing by Joseph C. Hassab. The system uses only the first 150 microseconds of ping energy to determine the hydrophone pair delays, to reject multipath echoes.

To find the bearing and elevation angle to the pinger, the calculated delays are used to solve a system of simultaneous equations that gives the required angles in terms of the delays. The system of equations is overconstrained, so the program computes a least-squares optimal solution. The equations are derived from the geometry of the hydrophone array and the plane wave approximation.

The calculations for each ping take about 80 ms. Once processing is complete, the bearing, elevation angle and frequency for the ping are transmitted to the main computer in an ASCII string for navigational use.

Control Computer

All navigation and control code is run under Linux on a Pentium-based PC/104+ embedded computer. This computing platform provides a stable and familiar programming environment, is amenable to remote operation, has modular standard peripherals and has a small install footprint. The ORCA-VI PC/104+ stack consists of a CPU card, a switching power supply, an eight serial port expansion card, and a frame grabber card. Most sensors and actuators interface to the computer using the RS-232 serial protocol.

Marker Drop Mechanism

The marker drop mechanism for ORCA-VII is comprised of two permanent electromagnets that each hold one 1.5 inch steel ball bearing marker. When off, the

device is a simple magnet that holds the marker in place. When the electromagnet creates a field that cancels the permanent magnet's field, allowing the marker to drop. Each electromagnet can be actuated independently. The permanent electromagnet provides power savings over an electromagnet since holding the markers in place, which is the state of the dropper for the majority of the time, requires no power.



The improve marker design is large, visible and stable

The permanent electromagnets operate on 24V from the motor bus, fits in a 1.5" square bounding box and weighs about 1 lb.

Software Development

For development and testing purposes a tether can be attached to the vehicle to make communication with the computer possible. The computer uses the Sun RPC protocol to communicate with multiple on-shore computers. From each station the vehicle can be remotely operated with a joystick, and all variables and sensor values can be inspected and modified with a graphical user interface. In addition, the main control program can be remotely modified and recompiled. All of this can be done while the submarine is submerged and operational. The control program has a simulation mode that uses a simple mathematical model of the pond and vehicle to generate simulated

non-ideal sensor data in response to motor commands. The simulator employs a rudimentary graphical user interface and a simplified graphical mock-up of the area. The simulation mode allows control code to be developed and debugged in the lab before it is tested in the water.

Tether and Data Link

The wireless data link is a pair of Freewave DGRO frequency-hopping spread spectrum data transceivers. These devices operate over the 902-928 MHz frequency band, transmitting at 1 W. They connect to the host computer using an RS-232 serial port and have a maximum data rate of 115 kbps/sec. In air, they have a 20-mile line-of-sight range, but with one unit underwater, depth becomes the limiting factor. In a chlorinated swimming pool, the units perform well up to a depth of about 1 m. Communication with the vehicle can also be established using a tether which provides an Ethernet link to the computer and a live video feed from the CCD camera. This allows team members to watch what the vehicle is doing while submerged, which has proven useful when debugging complex autonomous maneuvers.

Mission Control Software

The mission control software is implemented as a multithreaded Java program. Each sensor has an associated driver thread that communicates with the device and scales its data into engineering units. An autopilot thread keeps the vehicle's depth, heading, pitch, and speed at desired setpoints. The autopilot uses PID control on the four thrusters to servo the values returned by the pressure sensor, compass, inclinometer, and DVL to the desired setpoints.

Mission Plan

A pre-programmed state machine executes the mission plan. This section outlines the basic sequence of maneuvers the vehicle will use to complete the mission. Upon activation, the vehicle will dive to a cruising depth of 1.5 meters and will navigate through the validation gate using dead reckoning. Continuing to the target bin array, the vehicle will use the visual cue of the lit indicator lights home in on the bins. When an image with the bins is found, the image processing algorithm will give the location of the bin and the vehicle will center itself over the bins and drop the markers. When the markers are away, the vehicle will wait for a ping and correct its heading to face the acoustic beacon. The vehicle will navigate toward the acoustic beacon, correcting its course after each ping interval until it determines the beacon is below the vehicle. At this point the vehicle will surface and the mission run will be over.

Conclusion

The new mission for 2004 provided challenges that prompted several improvements on previous years' vehicles. The physical requirements encouraged our shift to a single dry compartment with external batteries. After the modifications and testing, we look forward to participating in the 2004 International AUV competition.