

Title	Oriented bordism and involutions
Author(s)	Komiya, Katsuhiko
Citation	Osaka Journal of Mathematics. 9(1) P.165-P.181
Issue Date	1972
Text Version	publisher
URL	<a href="https://doi.org/10.18910/8692">https://doi.org/10.18910/8692</a>
DOI	10.18910/8692
rights	
Note	

*Osaka University Knowledge Archive : OUKA*

<https://ir.library.osaka-u.ac.jp/>

Osaka University

## ORIENTED BORDISM AND INVOLUTIONS

KATSUHIRO KOMIYA

(Received May 12, 1971)

### 0. Introduction

Let  $(X, A)$  be a topological pair, and  $\tau : (X, A) \rightarrow (X, A)$  be an involution. For a triple  $(X, A, \tau)$ , R.E. Stong [7] defined the notions of the unoriented equivariant bordism groups  $\mathfrak{N}_*(X, A, \tau)$  and  $\hat{\mathfrak{N}}_*(X, A, \tau)$ , and studied their properties.

In this paper, we consider oriented analogues of  $\mathfrak{N}_*(X, A, \tau)$  and  $\hat{\mathfrak{N}}_*(X, A, \tau)$ . For a fixed involution  $(X, A, \tau)$ , let  $(M, \mu, f)$  be a triple with  $M$  a compact oriented differentiable manifold with boundary,  $\mu : M \rightarrow M$  an orientation-preserving [resp., -reversing] differentiable involution, and  $f : (M, \partial M) \rightarrow (X, A)$  a continuous equivariant map. We define for two such triples to be equivalent, or bordant in the same way as [7] but we consider oriented manifolds and orientation-preserving [resp., -reversing] involutions as bordism. We let  $\Omega_*^+(X, A, \tau)$  [resp.,  $\Omega_*^-(X, A, \tau)$ ] be the set of equivalence classes by this relation. These become graded  $\Omega$ -modules in the standard way, where  $\Omega$  is the oriented cobordism ring. As in [7], considering only fixed-point free differentiable involutions, we define also graded  $\Omega$ -modules  $\hat{\Omega}_*^+(X, A, \tau)$  and  $\hat{\Omega}_*^-(X, A, \tau)$ .

If  $A$  is empty, we write  $\Omega_*^+(X, \tau)$  for  $\Omega_*^+(X, A, \tau)$ , and so on.

The main results of this paper are as follows.

In section 2, we obtain

**Proposition 1.**  $\Omega_*^+( \quad ), \hat{\Omega}_*^+( \quad ), \Omega_*^-( \quad )$  and  $\hat{\Omega}_*^-( \quad )$  are equivariant generalized homology theories on the category of pairs with involution and equivariant maps.

In section 3, we introduce "equivariant cobordism groups"  $\Omega_*^*(X, A, \tau)$  and  $\hat{\Omega}_*^*(X, A, \tau)$  by using of suitable equivariant Thom spectra, and we prove the following dualities of Poincaré type.

**Proposition 2.** Let  $(X, A, \tau)$  be an involution on a compact pair  $(X, A)$  such that  $X - A$  is an  $n$ -dimensional oriented manifold without boundary, and

$\tau|X-A : X-A \rightarrow X-A$  is a fixed-point free differentiable involution. Then, if  $\tau|X-A$  preserves orientation,

$$\begin{aligned} \Omega_+^{\pm}(X, A, \tau) &\cong \Omega_{n-k}^{\pm}(X-A, \tau) (\cong \hat{\Omega}_{n-k}^{\pm}(X-A, \tau)) \\ \Omega_-^{\pm}(X, A, \tau) &\cong \Omega_{n-k}^{\mp}(X-A, \tau) (\cong \hat{\Omega}_{n-k}^{\mp}(X-A, \tau)) \end{aligned}$$

and if  $\tau|X-A$  reverses orientation,

$$\begin{aligned} \Omega_+^{\pm}(X, A, \tau) &\cong \Omega_{n-k}^{\mp}(X-A, \tau) (\cong \hat{\Omega}_{n-k}^{\mp}(X-A, \tau)) \\ \Omega_-^{\pm}(X, A, \tau) &\cong \Omega_{n-k}^{\pm}(X-A, \tau) (\cong \hat{\Omega}_{n-k}^{\pm}(X-A, \tau)). \end{aligned}$$

In section 4, we explore nature of the fixed-point set of involutions. For this purpose, we introduce the graded  $\Omega$ -modules  $\mathfrak{A}_*^{\pm}(X, A)$  and  $\mathfrak{A}_*^{\mp}(X, A)$  for any pair  $(X, A)$ , which are defined to be the set of equivalence classes of triples  $(\zeta \rightarrow M, \mathcal{O}, f)$  wherein  $\zeta \rightarrow M$  is a vector bundle over a compact manifold  $M$  with boundary,  $\mathcal{O}$  is an orientation of the Whitney sum  $\zeta \oplus \tau_M$ ,  $\tau_M$  the tangent bundle of  $M$ , and  $f : (M, \partial M) \rightarrow (X, A)$  is a continuous map. We have

**Proposition 3.** *The triangles*

$$\begin{array}{ccc} \hat{\Omega}_*^{\pm}(X, A, \tau) & \xrightarrow{k_*} & \Omega_*^{\pm}(X, A, \tau), \hat{\Omega}_*^{\mp}(X, A, \tau) & \xrightarrow{k_*} & \Omega_*^{\mp}(X, A, \tau) \\ S \swarrow & & \searrow F & & S \swarrow & & \searrow F \\ & & \mathfrak{A}_*^{\pm}(F_{\tau}, F_{\tau} \cap A) & & \mathfrak{A}_*^{\mp}(F_{\tau}, F_{\tau} \cap A) \end{array}$$

are exact, where  $F_{\tau}$  is the fixed-point set of  $\tau$ ,  $k_*$  forgets freeness,  $F$  is obtained by taking the normal bundle of the fixed-point set, and  $S$  is obtained from a sphere bundle construction.

In section 5, we define the Smith homomorphisms  $\Delta : \hat{\Omega}_*^{\pm}(X, A, \tau) \rightarrow \hat{\Omega}_*^{\mp}(X, A, \tau)$  and  $\Delta : \hat{\Omega}_*^{\mp}(X, A, \tau) \rightarrow \hat{\Omega}_*^{\pm}(X, A, \tau)$ , which are of degree  $-1$ , and prove

**Proposition 4.** *The triangles*

$$\begin{array}{ccc} \hat{\Omega}_*^{\pm}(X, A, \tau) & \xrightarrow{\Delta} & \hat{\Omega}_*^{\mp}(X, A, \tau), \hat{\Omega}_*^{\mp}(X, A, \tau) & \xrightarrow{\Delta} & \hat{\Omega}_*^{\pm}(X, A, \tau) \\ 1+\tau_* \swarrow & & \searrow \mathcal{L}_* & & 1-\tau_* \swarrow & & \searrow \mathcal{L}_* \\ & & \Omega_*(X, A) & & \Omega_*(X, A) \end{array}$$

are exact, where  $\mathcal{L}_*$  forgets equivariance,  $1+\tau_*$  sends  $[M, f]$  into  $[M \cup M, c, f \cup \tau f]$ ,

$c$  the involution changing components, and  $1-\tau_*$  sends  $[M, f]$  into  $[M \cup (-M), c, f \cup \tau f]$ ,  $-M$  the manifold with reversed orientation of  $M$ .

In section 6, we study connection between our oriented equivariant bordism groups  $\hat{\Omega}_*^+(X, A, \tau)$ ,  $\hat{\Omega}_*^-(X, A, \tau)$  and Stong's unoriented equivariant bordism group  $\hat{\mathfrak{U}}_*(X, A, \tau)$ , and we obtain the exact triangles of the type of Dold [5].

**Proposition 8.** *The triangles*

$$\begin{array}{ccc} \hat{\Omega}_*^+(X, A, \tau) \oplus \hat{\mathfrak{U}}_*(X, A, \tau) & \xrightarrow{(2, 0)} & \hat{\Omega}_*^+(X, A, \tau) \\ & \swarrow (\partial, d) & \searrow F \\ & \hat{\mathfrak{U}}_*(X, A, \tau) & \end{array}$$

and

$$\begin{array}{ccc} \hat{\Omega}_*^-(X, A, \tau) \oplus \hat{\mathfrak{U}}_*(X, A, \tau) & \xrightarrow{(2, 0)} & \hat{\Omega}_*^-(X, A, \tau) \\ & \swarrow (\partial, d) & \searrow F \\ & \hat{\mathfrak{U}}_*(X, A, \tau) & \end{array}$$

are exact, where 2 is the multiplication by the integer 2, 0 is the zero homomorphism,  $F$  forgets orientedness, and  $\partial$  and  $d$  are of degree  $-1$  and  $-2$ , respectively.

The author wishes to express his thanks to Professors M. Nakaoka and F. Uchida, and Mr. K. Shibata for their useful suggestions and criticisms for writing this paper.

**1. Definitions**

Let an involution  $(X, A, \tau)$  be fixed. We consider a triple  $(M, \mu, f)$  with  $M$  a compact oriented differentiable manifold with boundary,  $\mu : M \rightarrow M$  an orientation-preserving [resp., -reversing] differentiable involution, and  $f : (M, \partial M) \rightarrow (X, A)$  a continuous equivariant map. We identify  $(M, \mu, f)$  with  $(M', \mu', f')$  if and only if there exists an orientation-preserving diffeomorphism  $\varphi : M \approx M'$  such that  $\mu' \varphi = \varphi \mu$  and  $f = f' \varphi$ .  $(M, \mu, f)$  is called *bordant* to  $(M', \mu', f')$  if and only if there exists a 4-tuple  $(W, V, \nu, g)$  such that  $W$  and  $V$  are compact oriented manifolds with boundary,  $\partial V = \partial M \cup -\partial M'$  (disjoint union) and  $\partial W = M \cup V \cup -M'$  (glueing the boundaries),  $\nu : (W, V) \rightarrow (W, V)$  is an orientation-preserving [resp., -reversing] differentiable involution which restricts to  $\mu$  on  $M$ , and  $\mu'$  on  $M'$ , and  $g : (W, V) \rightarrow (X, A)$  is a continuous equivariant map which restricts to  $f$  on  $M$ , and  $f'$  on  $M'$ . We denote the bordism class of  $(M, \mu, f)$  by  $[M, \mu, f]$ .

Let  $\Omega_*^+(X, A, \tau)$  [resp.,  $\Omega_*^-(X, A, \tau)$ ] be the set of bordism classes by this bordism relation. Then  $\Omega_*^+(X, A, \tau)$  [resp.,  $\Omega_*^-(X, A, \tau)$ ] is made an abelian group by the disjoint union of triples, and a graded group by the gradation given by the dimension of the manifold  $M$ . For any class  $[M, \mu, f]$  in  $\Omega_*^+(X, A, \tau)$  [resp.,  $\Omega_*^-(X, A, \tau)$ ], and  $[N]$  in the oriented cobordism ring  $\Omega$ , we define

$$[M, \mu, f] [N] = [M \times N, \mu \times 1, f\pi_1]$$

where  $\pi_1 : M \times N \rightarrow M$  is the projection to the first factor. This makes  $\Omega_*^+(X, A, \tau)$  [resp.,  $\Omega_*^-(X, A, \tau)$ ] a graded  $\Omega$ -module.

Considering only fixed-point free orientation-preserving [resp., -reversing] differentiable involutions as  $\mu, \mu', \nu, \dots$ , we may also define a graded  $\Omega$ -module  $\hat{\Omega}_*^+(X, A, \tau)$  [resp.,  $\hat{\Omega}_*^-(X, A, \tau)$ ].

### 2. Equivariant homology theories

Let  $\mathcal{H}_n(X, A, \tau)$  denote one of  $\Omega_n^+(X, A, \tau), \Omega_n^-(X, A, \tau), \hat{\Omega}_n^+(X, A, \tau)$  and  $\hat{\Omega}_n^-(X, A, \tau)$ . Given an equivariant map  $g : (X, A, \tau) \rightarrow (X', A', \tau')$ , we define a homomorphism  $\mathcal{H}_n(g) : \mathcal{H}_n(X, A, \tau) \rightarrow \mathcal{H}_n(X', A', \tau')$  by sending  $[M, \mu, f]$  into  $[M, \mu, gf]$ . We also define a homomorphism  $\partial_n : \mathcal{H}_n(X, A, \tau) \rightarrow \mathcal{H}_{n-1}(A, \tau)$  by sending  $[M, \mu, f]$  into  $[\partial M, \mu, f]$ . We then have

**Proposition 1.** (1) *If  $g, g'$  are equivariantly homotopic maps, then  $\mathcal{H}_n(g) = \mathcal{H}_n(g')$ .*

(2) *If  $U$  is an invariant open set with  $\bar{U} \subset \text{Int } A$ ,  $A$  closed, then the inclusion  $i : (X - U, A - U) \rightarrow (X, A)$  induces an isomorphism  $\mathcal{H}_n(i) : \mathcal{H}_n(X - U, A - U, \tau) \rightarrow \mathcal{H}_n(X, A, \tau)$ .*

(3) *The sequence*

$$\begin{aligned} \dots \rightarrow \mathcal{H}_n(A, \tau) &\xrightarrow{\mathcal{H}_n(i)} \mathcal{H}_n(X, \tau) \xrightarrow{\mathcal{H}_n(j)} \mathcal{H}_n(X, A, \tau) \\ &\xrightarrow{\partial_n} \mathcal{H}_{n-1}(A, \tau) \rightarrow \dots \end{aligned}$$

*with  $(A, \phi, \tau) \xrightarrow{i} (X, \phi, \tau) \xrightarrow{j} (X, A, \tau)$  the inclusions, is exact.*

The proof is an obvious repetition of the proof given by Stong [7], taking care of orientability and orientedness.

REMARK. This makes  $\{\mathcal{H}_n, \partial_n\}$  an equivariant generalized homology theory on the category of pairs with involution and equivariant maps, as defined by Bredon [2].

### 3. Dualities of Poincaré type

In this section, we define the “equivariant cobordism groups”  $\Omega_*^+(X, A, \tau)$

and  $\Omega^*(X, A, \tau)$  by using of suitable equivariant Thom spectra, and prove that there are dualities of Poincaré type between these cobordism groups and the bordism groups in the previous sections.

Let  $ESO(n) \rightarrow BSO(n)$  be the  $n$ -dimensional universal oriented vector bundle, and  $MSO(n)$  be its Thom space. We may consider  $BSO(n)$  as the set of all  $n$ -dimensional oriented subspaces in the infinite dimensional euclidean space  $R^\infty$ , and  $ESO(n)$  as the set of pairs  $(v, H)$  with  $v$  a vector in an  $n$ -dimensional oriented subspace  $H$  in  $R^\infty$ . Then we define involutions as bundle map  $\iota_n^+, \iota_n^- : ESO(n) \rightarrow ESO(n)$  by  $\iota_n^+(v, H) = (v, H)$ ,  $\iota_n^-(v, H) = (v, -H)$ ,  $-H$  the subspace with the reversed orientation of  $H$ .

REMARK.  $ESO(n)/\iota_n^- \rightarrow BSO(n)/\bar{\iota}_n^-$  is the  $n$ -dimensional universal unoriented vector bundle, where  $\bar{\iota}_n^-$  is the involution on  $BSO(n)$  covered by  $\iota_n^-$ .

**Lemma 1.** *Let  $E \rightarrow B$  an  $n$ -dimensional oriented vector bundle with a fixed-point free involution  $(\alpha, \bar{\alpha})$  as bundle map such that  $B$  is paracompact or  $B/\bar{\alpha}$  is paracompact and Hausdorff<sup>1)</sup>. Then, if  $\alpha$  is orientation-preserving, there exists an equivariant bundle map  $\varphi : (E, \alpha) \rightarrow (ESO(n), \iota_n^+)$ , and if  $\alpha$  is orientation-reversing, there exists an equivariant bundle map  $\varphi : (E, \alpha) \rightarrow (ESO(n), \iota_n^-)$ . In the both cases, moreover,  $\varphi$  uniquely exists up to equivariant bundle homotopy.*

Proof. If  $\alpha$  is orientation-preserving, the Lemma is clear, since  $E/\alpha \rightarrow B/\bar{\alpha}$  is also an oriented bundle. If  $\alpha$  is orientation-reversing, we obtain a diagram of bundle maps

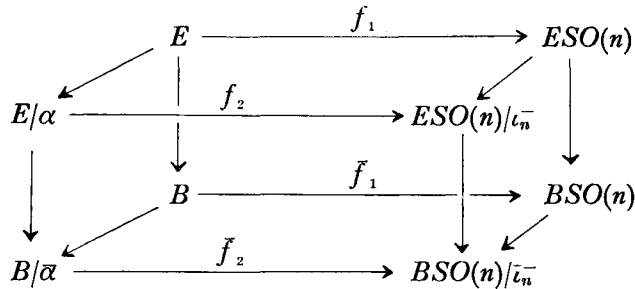

in which  $\bar{f}_1$  is a classifying map of  $E \rightarrow B$ ,  $\bar{f}_2$  is that of  $E/\alpha \rightarrow B/\bar{\alpha}$ ,  $f_1$  and  $f_2$  are bundle maps covering  $\bar{f}_1$  and  $\bar{f}_2$ , respectively, and the each slant arrow is the natural projection to the orbit space. The upper and lower squares are homotopy commutative by universality. We may deform these homotopy commutative squares to be strictly commutative, since the slant arrows are double coverings, i.e., fibrations. The Lemma thus follows.

<sup>1)</sup> If  $B$  is paracompact, then  $B/\bar{\alpha}$  is so. Conversely, if  $B/\bar{\alpha}$  is paracompact and Hausdorff, then  $B$  is paracompact.

Let  $TE$  denote the Thom space of a vector bundle  $E \rightarrow B$ . Let  $\alpha$  be an involution on  $E$  as bundle map. We also denote the involution on  $TE$  induced from  $\alpha$  by  $\alpha$ . This will cause no confusion. We then have the following Corollary.

**Corollary 1.** *Under the same assumption as Lemma 1, if  $\alpha$  is orientation-preserving, there exists an equivariant map  $\psi : (TE, \alpha) \rightarrow (MSO(n), \iota_n^+)$ , and if  $\alpha$  is an orientation-reversing, there exists an equivariant map  $\psi : (TE, \alpha) \rightarrow (MSO(n), \iota_n^-)$ . In the both cases, moreover, as a map induced from a bundle map,  $\psi$  is unique up to equivariant homotopy.*

Let  $X$  be a space with base point  $*$ , and  $\tau : X \rightarrow X$  be an involution with base point preserving. We then define the suspension  $\Sigma X = X \times [0, 1] / * \times [0, 1] \cup X \times \{0, 1\}$  of  $X$ , and the involution  $\Sigma \tau : \Sigma X \rightarrow \Sigma X$  induced by  $\tau \times 1$ .

We obtain equivariant maps

$$h_n^+ : (\Sigma MSO(n), \Sigma \iota_n^+) \rightarrow (MSO(n+1), \iota_{n+1}^+)$$

and

$$h_n^- : (\Sigma MSO(n), \Sigma \iota_n^-) \rightarrow (MSO(n+1), \iota_{n+1}^-)$$

as follows.  $h_n^+$  is obtained from a bundle map  $ESO(n) \times R^1 \rightarrow ESO(n+1)$ , and  $h_n^-$  is obtained by applying Corollary 1 to the involution  $(ESO(n) \times R^1, \iota_n^- \times 1)$ . We can now define the equivariant spectra

$$MSO^+ = \{(MSO(n), \iota_n^+), h_n^+\}$$

and

$$MSO^- = \{(MSO(n), \iota_n^-), h_n^-\}.$$

For any  $(X, A, \tau)$ , we define

$$\Omega_+^n(X, A, \tau) = \lim_{k \rightarrow \infty} [(\Sigma^k(X/A), \Sigma^k \tau), (MSO(n+k), \iota_{n+k}^+)],$$

$$\Omega_-^n(X, A, \tau) = \lim_{k \rightarrow \infty} [(\Sigma^k(X/A), \Sigma^k \tau), (MSO(n+k), \iota_{n+k}^-)],$$

where  $[ , ]$  denotes the equivariant homotopy set. Then  $\Omega_+^*( )$  and  $\Omega_-^*( )$  are equivariant generalized cohomology theories on the category of CW-pair  $(X, A)$  with cellular involution  $\tau$  whose fixed-point set is a subcomplex of  $X$ , and equivariant maps (see Bredon[2]).

REMARK. By the definition, we can easily see  $\Omega_+^*(X, A, 1) = \Omega^*(X, A)$ , and  $\Omega_-^*(X, A, 1) = 0$ , where  $\Omega^*(X, A)$  is the cobordism group of a pair  $(X, A)$  defined by Atiyah [1].

**Proposition 2.** *If  $(X, A, \tau)$  is an involution on a compact pair  $(X, A)$  such that  $X - A$  is an  $n$ -dimensional oriented manifold without boundary, and  $\tau|_{X-A} : X - A \rightarrow X - A$  is a fixed-point free differentiable involution, then if  $\tau|_{X-A}$  preserves orientation,*

$$\begin{aligned} \Omega_+^{\pm}(X, A, \tau) &\cong \Omega_{n-k}^{\pm}(X-A, \tau) (\cong \hat{\Omega}_{n-k}^{\pm}(X-A, \tau)) \\ \Omega_{\pm}^{\pm}(X, A, \tau) &\cong \Omega_{n-k}^{\mp}(X-A, \tau) (\cong \hat{\Omega}_{n-k}^{\mp}(X-A, \tau)), \end{aligned}$$

and if  $\tau|_{X-A}$  reverses orientation,

$$\begin{aligned} \Omega_+^{\pm}(X, A, \tau) &\cong \Omega_{n-k}^{\mp}(X-A, \tau) (\cong \hat{\Omega}_{n-k}^{\mp}(X-A, \tau)) \\ \Omega_{\pm}^{\pm}(X, A, \tau) &\cong \Omega_{n-k}^{\pm}(X-A, \tau) (\cong \hat{\Omega}_{n-k}^{\pm}(X-A, \tau)). \end{aligned}$$

REMARK. For any involution  $(Y, B, \sigma)$  with  $\sigma$  fixed-point free, we can easily see  $\Omega_{\ast}^{\pm}(Y, B, \sigma) \cong \hat{\Omega}_{\ast}^{\pm}(Y, B, \sigma)$  and  $\Omega_{\mp}^{\pm}(Y, B, \sigma) \cong \hat{\Omega}_{\mp}^{\pm}(Y, B, \sigma)$ . In more general, if the fixed-point set  $F_{\sigma}$  of  $\sigma$  is contained in  $B$ , the above isomorphisms also exist by Proposition 3.

We prepare the following Lemma for the proof of Proposition 2.

**Lemma 2.** *Let  $D^r$  be an  $r$ -dimensional disc. For any involution  $(X, A, \tau)$ , there is an equivariant homeomorphism*

$$(\sum^r(X/A), \sum^r\tau) \approx (X \times D^r / X \times \partial D^r \cup A \times D^r, \tau \times 1).$$

Outline of the proof of Proposition 2. The proofs of isomorphichness in four cases are similar, so we suppose  $\tau|_{X-A}$  preserves orientation and  $[M, \mu, f] \in \Omega_+^{\pm}(X-A, \tau)$ . We consider  $if : (M, \mu) \xrightarrow{f} ((X-A) \times 0, \tau \times 1) \xrightarrow{i} ((X-A) \times D^r, \tau \times 1)$ . For large  $r$ , there exists a differentiable imbedding  $g : (M, \mu) \rightarrow ((X-A) \times D^r, \tau \times 1)$  which is equivariantly homotopic to  $if$  and satisfies  $g(M) \cap (X-A) \times \partial D^r = \emptyset$ . Let  $N$  be the the normal bundle of  $g$ , and  $TN$  be its Thom space. Then we have an equivariant map  $\psi : (TN, d(\tau \times 1)) \rightarrow (MSO(n+r-k), \iota_{n+r-k}^+)$  by Corollary 1. Let  $\alpha$  be the composition

$$\begin{aligned} (\sum^r(X/A), \sum^r\tau) &\approx (X \times D^r / X \times \partial D^r \cup A \times D^r, \tau \times 1) \\ &\xrightarrow{c} (TN, d(\tau \times 1)) \xrightarrow{\psi} (MSO(n+r-k), \iota_{n+r-k}^+), \end{aligned}$$

where, identifying a disc bundle of  $N$  with a tubular neighborhood  $T$  of  $g(M)$ ,  $c$  is the collapsing outside  $T$ , and the identity on  $T$ . Sending  $[M, \mu, f]$  into the class of  $\alpha$ , we have the desired isomorphism.

#### 4. Nature of the fixed-point set

In this section, we obtain an oriented analogue of Proposition 2 in [7]. Let a pair  $(X, A)$  be fixed. We consider a triple  $(\zeta \rightarrow M, \mathcal{O}, f)$ , wherein  $\zeta \rightarrow M$  is a vector bundle over a compact manifold  $M$  with boundary,  $\mathcal{O}$  is an orientation of the Whitney sum  $\zeta \oplus_{\tau_M} \tau_M$  the tangent bundle of  $M$ , and  $f : (M, \partial M) \rightarrow (X, A)$



is a continuous map. We identify  $(\zeta \rightarrow M, \mathcal{O}, f)$  with  $(\zeta' \rightarrow M', \mathcal{O}', f')$  if and only if there is a bundle isomorphism

$$\begin{array}{ccc} \zeta & \xrightarrow{\Phi} & \zeta' \\ \downarrow & & \downarrow \\ M & \xrightarrow{\varphi} & M' \end{array}$$

such that 1)  $\varphi$  is a diffeomorphism, 2)  $f\varphi' = f$ , and 3)  $\Phi \oplus d\varphi : \zeta \oplus \tau_M \rightarrow \zeta' \oplus \tau_{M'}$  preserves the orientation. Let  $-(\zeta \rightarrow M, \mathcal{O}, f) = (\zeta \rightarrow M, -\mathcal{O}, f)$ .

A boundary operator  $\partial$  is defined by

$$\partial(\zeta \rightarrow M, \mathcal{O}, f) = (\zeta|_{\partial M} \rightarrow \partial M, \partial\mathcal{O}, f|_{\partial M}).$$

The orientation  $\partial\mathcal{O}$  of  $(\zeta|_{\partial M}) \oplus \tau_{\partial M}$  is defined as follows. If  $\nu$  is the normal bundle of  $\partial M \subset M$ , then  $(\zeta \oplus \tau_M)|_{\partial M} = (\zeta|_{\partial M}) \oplus \tau_{\partial M} \oplus \nu$  inherits an orientation from  $\mathcal{O}$ .  $\partial\mathcal{O}$  is the orientation which is compatible with those of  $(\zeta \oplus \tau_M)|_{\partial M}$  and  $\nu$ ,  $\nu$  being oriented by the inner unit normal vector.

If  $\zeta_i^k \rightarrow M_i^n$  ( $i=1, 2$ ) are  $k$ -dimensional vector bundles over  $n$ -dimensional compact manifolds, then  $(\zeta_1^k \rightarrow M_1^n, \mathcal{O}_1, f_1)$  is *bordant* to  $(\zeta_2^k \rightarrow M_2^n, \mathcal{O}_2, f_2)$  if and only if there is a 4-tuple  $(\zeta^k \rightarrow W^{n+1}, V^n, \mathcal{O}, f)$  such that  $\partial V = \partial M_1 \cup \partial M_2$  (disjoint union),  $\partial W = M_1 \cup V \cup M_2$  (glueing the boundaries),  $f : (W, V) \rightarrow (X, A)$ ,  $\partial(\zeta \rightarrow W, \mathcal{O}, f)|_{M_1} = (\zeta_1 \rightarrow M_1, \mathcal{O}_1, f_1)$ , and  $\partial(\zeta \rightarrow W, \mathcal{O}, f)|_{M_2} = -(\zeta_2 \rightarrow M_2, \mathcal{O}_2, f_2)$ . Denote a bordism class by  $[\zeta^k \rightarrow M^n, \mathcal{O}, f]$ , and the set of such bordism classes by  $A(k, n; (X, A))$ . This is an abelian group by the disjoint union. We can now define the graded  $\Omega$ -modules

$$\mathfrak{A}_*^+(X, A) = \bigoplus_{m \geq 0} \mathfrak{A}_m^+(X, A), \text{ where } \mathfrak{A}_m^+(X, A) = \bigoplus_{2k+n=m} A(2k, n; (X, A)), \text{ and}$$

$$\mathfrak{A}_*^-(X, A) = \bigoplus_{m \geq 0} \mathfrak{A}_m^-(X, A), \text{ where } \mathfrak{A}_m^-(X, A) = \bigoplus_{2k+1+n=m} A(2k+1, n; (X, A)).$$

$\mathfrak{A}_*^+(\text{pt}, 1) = \mathfrak{A}$  in the notation of [3].

The fixed-point set  $F_\mu$  of a differentiable involution  $\mu : M \rightarrow M$  is a manifold with boundary  $\partial F_\mu = F_\mu \cap \partial M$ . Let  $F_\mu^m$  be the union of the  $m$ -dimensional components of  $F_\mu$ , and  $\nu_m$  be the normal bundle of  $F_\mu^m \subset M$ . Then  $F_\mu^m = \emptyset$ , if  $\mu$  is orientation-preserving and  $m$  is odd, or  $\mu$  is orientation-reversing and  $m$  is even. Therefore we can define homomorphisms  $F : \Omega_*^+(X, A, \tau) \rightarrow \mathfrak{A}_*^+(F_\tau, F_\tau \cap A)$ , and  $F : \Omega_*^-(X, A, \tau) \rightarrow \mathfrak{A}_*^-(F_\tau, F_\tau \cap A)$ , by sending  $[M^n, \mu, f]$  into  $\bigoplus_{m=0}^n [\nu_m \rightarrow F_\mu^m, \mathcal{O}_m, f|_{F_\mu^m}]$ , where  $\mathcal{O}_m$  is the orientation restricted by that of  $M$ .

We also obtain homomorphisms  $S : \mathfrak{A}_*^+(F_\tau, F_\tau \cap A) \rightarrow \hat{\Omega}_*^+(X, A, \tau)$ , and  $S : \mathfrak{A}_*^-(F_\tau, F_\tau \cap A) \rightarrow \hat{\Omega}_*^-(X, A, \tau)$ , of degree  $-1$ , by sending  $[\zeta \rightarrow M, \mathcal{O}, f]$

into  $[S(\zeta), a, f\pi]$ , where  $S(\zeta)$  is the associated sphere bundle to  $\zeta$ , this is canonically oriented by  $\mathcal{O}$ ,  $a$  is the antipodal bundle involution on  $S(\zeta)$ , and  $f\pi : S(\zeta) \subset \zeta \xrightarrow{\pi} M \xrightarrow{f} F_\tau \subset X$ .

Letting  $k_* : \hat{\Omega}_*^+(X, A, \tau) \rightarrow \Omega_*^+(X, A, \tau)$ , and  $k_* : \hat{\Omega}_*^-(X, A, \tau) \rightarrow \Omega_*^-(X, A, \tau)$  be the homomorphisms induced by forgetting freeness, we then have

**Proposition 3.** *The triangles*

$$\begin{array}{ccccc}
 \hat{\Omega}_*^+(X, A, \tau) & \xrightarrow{k_*} & \Omega_*^+(X, A, \tau) & , & \hat{\Omega}_*^-(X, A, \tau) & \xrightarrow{k_*} & \Omega_*^-(X, A, \tau) \\
 S \swarrow & & \searrow F & & S \swarrow & & \searrow F \\
 \mathfrak{A}_*^+(F_\tau, F_\tau \cap A) & & & & \mathfrak{A}_*^-(F_\tau, F_\tau \cap A) & & 
 \end{array}$$

are exact.

This is proved by the same technic as [7], so we omit the proof.

**5. The Smith homomorphisms**

Let  $(S^k, a)$  be the antipodal involution on the  $k$ -dimensional sphere. The Smith homomorphisms in the oriented case are defined as follows. For a triple  $(M, \mu, f)$  with  $\mu$  free, and large  $k$ , there is an equivariant map  $\lambda : (M, \mu) \rightarrow (S^k, a)$  which is transverse regular on  $S^{k-1}$ . We set  $N = \lambda^{-1}(S^{k-1})$ , then  $N$  has the orientation induced from  $M$ . The involution  $\mu|N : N \rightarrow N$  is orientation-preserving if  $\mu$  is reversing, or reversing if  $\mu$  is preserving. Sending  $[M, \mu, f]$  into  $[N, \mu|N, f|N]$ , we obtain the Smith homomorphisms  $\Delta : \hat{\Omega}_*^+(X, A, \tau) \rightarrow \hat{\Omega}_*^-(X, A, \tau)$ , and  $\Delta : \hat{\Omega}_*^-(X, A, \tau) \rightarrow \hat{\Omega}_*^+(X, A, \tau)$ , of degree  $-1$ .

REMARK. We easily check that any element in the image of  $\Delta$  is of order 2.

We also define homomorphisms  $\mathcal{L}_* : \hat{\Omega}_*^+(X, A, \tau) \rightarrow \Omega_*(X, A)$  and  $\mathcal{L}_* : \hat{\Omega}_*^-(X, A, \tau) \rightarrow \Omega_*(X, A)$  sending  $[M, \mu, f]$  into  $[M, f], 1 + \tau_* : \Omega_*(X, A) \rightarrow \hat{\Omega}_*^+(X, A, \tau)$  sending  $[M, f]$  into  $[M \cup M, c, f \cup \tau f]$ ,  $c$  the involution changing components, and  $1 - \tau_* : \Omega_*(X, A) \rightarrow \hat{\Omega}_*^-(X, A, \tau)$  sending  $[M, f]$  into  $[M \cup (-M), c, f \cup \tau f]$ ,  $-M$  the manifold with reversed orientation of  $M$ .

**Proposition 4.** *The triangles*

$$\begin{array}{ccccc}
 \hat{\Omega}_*^+(X, A, \tau) & \xrightarrow{\Delta} & \hat{\Omega}_*^-(X, A, \tau) & , & \hat{\Omega}_*^-(X, A, \tau) & \xrightarrow{\Delta} & \hat{\Omega}_*^+(X, A, \tau) \\
 1 + \tau_* \swarrow & & \searrow \mathcal{L}_* & & 1 - \tau_* \swarrow & & \searrow \mathcal{L}_* \\
 \Omega_*(X, A) & & & & \Omega_*(X, A) & & 
 \end{array}$$

are exact.

The proof is entirely parallel to the proof in the unoriented case [7], taking care of orientability and orientedness, so we omit the proof.

**6. Connection between  $\hat{\Omega}_*(X, A, \tau)$ ,  $\hat{\Omega}_*(X, A, \tau)$  and  $\mathfrak{Y}_{\mathbb{Z}_2}^*(X, A, \tau)$**

Wall [8] defined the subring  $\mathfrak{M}$  of the unoriented cobordism ring  $\mathfrak{N}$ , and the homomorphism  $\partial : \mathfrak{M} \rightarrow \Omega$  of degree  $-1$ , and he obtained the exact triangle

$$\begin{array}{ccc}
 \Omega & \xrightarrow{2} & \Omega \\
 \partial \swarrow & & \searrow F \\
 & \mathfrak{M} &
 \end{array}$$

where 2 is the multiplication by the integer 2, and  $F$  is the homomorphism forgetting orientation. Dold [5] generalized this exact triangle and obtained the exact triangle

$$\begin{array}{ccc}
 \Omega \oplus \mathfrak{N} & \xrightarrow{(2, 0)} & \Omega \\
 (\partial, d) \swarrow & & \searrow F \\
 & \mathfrak{N} &
 \end{array}$$

In this section, we obtain exact triangles of the type of Wall and Dold in our equivariant case.

If  $\eta$  is an  $n$ -dimensional vector bundle, the determinant bundle,  $\det \eta$ , is the line bundle  $\Lambda^n(\eta)$  giving by the  $n$ -fold exterior power of the bundle  $\eta$ . We easily see the followings:  $\det(\eta \oplus \eta') \cong \det \eta \otimes \det \eta'$ , if  $\rho$  is a line bundle then  $\det \rho = \rho$ , and if  $\theta^1$  is a trivial line bundle then  $\det(\eta \oplus \theta^1) \cong \det \eta$ .

Considering the determinant bundle of the tangent bundle  $\tau_M$  of a manifold  $M$ ,  $\det \tau_M$  is oriented if and only if  $M$  is oriented. Therefore, if  $M$  is oriented and we give a Riemannian metric on  $M$ , we canonically have the trivialization  $\det \tau_M \cong M \times R^1$ . Then we obtain

**Lemma 3.** *If  $\mu : M \rightarrow M$  is an involution on an oriented manifold  $M$ , then  $\mu$  is orientation-preserving or -reversing if and only if  $\det d\mu = \mu \times 1$  or  $\det d\mu = \mu \times (-1)$ , respectively.*

Let  $\xi \rightarrow RP(\infty)$  be the universal line bundle, and  $\alpha : M \rightarrow RP(\infty)$  be a classifying map of  $\det \tau_M$ . If  $M$  is compact, then  $\alpha(M) \subset RP(r)$  for some  $r \geq 0$ . Such  $\alpha$  is called an  $RP(r)$ -structure of  $M$ .

Let an involution  $(X, A, \tau)$  be fixed. We consider a 4-tuple  $(M, \mu, f, \alpha)$ , wherein  $(M, \mu, f)$  is a triple with  $\mu$  free in the previous sections but  $M$  is unoriented, and  $\alpha$  is an equivariant  $RP(1)$ -structure of  $M$  satisfying  $\bar{\alpha} \circ \det d\mu = \bar{\alpha}$  or  $\bar{\alpha} \circ (-\det d\mu) = \bar{\alpha}$  for some bundle map  $\bar{\alpha}$  covering  $\alpha$ , where  $-\det d\mu = (-1) \circ \det d\mu$ . We identify  $(M, \mu, f, \alpha)$  with  $(M', \mu', f', \alpha')$  if and only if there is a diffeomorphism  $M \approx M'$  which is equivariant under  $\mu$  and  $\mu', f$  and  $f'$ , and  $\alpha$  and  $\alpha'$ . We identify  $\det \tau_{\partial M}$  with  $\det \tau_M | \partial M$  by the inner unit normal vector. Then we define that  $(M, \mu, f, \alpha)$  is *bordant* to  $(M', \mu', f', \alpha')$  if and only if  $(M, \mu, f)$  is bordant to  $(M', \mu', f')$  with bordism  $(W, V, \nu, g)$  in the sense of Stong [7], and  $W$  has an equivariant  $RP(1)$ -structure  $\beta$  satisfying  $\beta | M = \bar{\alpha}$  and  $\beta | M' = \bar{\alpha}'$ , where  $\bar{\alpha}, \bar{\alpha}'$ , and  $\beta$  are bundle maps covering  $\alpha, \alpha'$  and  $\beta$ , respectively. We may define the graded  $\mathfrak{M}$ -modules  $\hat{\mathfrak{M}}_*(X, A, \tau)$  and  $\hat{\mathfrak{M}}_*(X, A, \tau)$  by dividing the sets  $\{(M, \mu, f, \alpha) | \bar{\alpha} \circ \det d\mu = \bar{\alpha}\}$  and  $\{(M, \mu, f, \alpha) | \bar{\alpha} \circ (-\det d\mu) = \bar{\alpha}\}$  by this bordism relation, respectively.

There are homomorphisms  $F : \hat{\mathfrak{M}}_*(X, A, \tau) \rightarrow \mathfrak{M}_*(X, A, \tau)$  and  $F : \hat{\mathfrak{M}}_*(X, A, \tau) \rightarrow \mathfrak{M}_*(X, A, \tau)$  which forget an  $RP(1)$ -structure.

**Proposition 5.** *The two homomorphisms  $F$  are monic. Moreover, the image of  $F$  is direct summand of  $\mathfrak{M}_*(X, A, \tau)$ .*

Proof. It is sufficient to construct homomorphisms  $\Phi : \mathfrak{M}_*(X, A, \tau) \rightarrow \hat{\mathfrak{M}}_*(X, A, \tau)$  and  $\Phi : \mathfrak{M}_*(X, A, \tau) \rightarrow \hat{\mathfrak{M}}_*(X, A, \tau)$  satisfying  $\Phi F = id$ .

Let  $\varepsilon$  denote one of the signs  $+$  and  $-$ . Given a class  $[M, \mu, f] \in \mathfrak{M}_*(X, A, \tau)$ , there is an equivariant bundle map  $\bar{h} : (\det \tau_M, \varepsilon \det d\mu) \rightarrow (\xi_r, 1)$ , where  $\xi_r$  is the canonical line bundle over  $RP(r)$ ,  $r$  large, and  $1$  is the identity bundle map of  $\xi_r$ . Let  $h : (M, \mu) \rightarrow (RP(r), 1)$  be the map covered by  $\bar{h}$ , and  $\varphi : RP(r) \times RP(1) \rightarrow RP(2r+1)$  be the usual imbedding given by

$$\varphi([x_0, x_1, \dots, x_r], [y_0, y_1]) = [x_0 y_0, x_0 y_1, x_1 y_0, x_1 y_1, \dots, x_r y_0, x_r y_1].$$

Then we have an equivariant bundle map

$$\begin{array}{ccc} ((\det \tau_M \hat{\otimes} \xi_1, \varepsilon \det d\mu \hat{\otimes} 1) \rightarrow (\xi_{2r+1}, 1)) & & \\ \downarrow & & \downarrow \\ (M \times RP(1), \mu \times 1) & \xrightarrow{\varphi \circ (h \times 1)} & (RP(2r+1), 1) \end{array}$$

in which  $\hat{\otimes}$  denotes the external tensor product. By means of a homotopy we may equivariantly deform  $\varphi \circ (h \times 1)$  to  $\theta$  which is transverse regular on  $RP(2r)$ . We set  $N = \theta^{-1}(RP(2r))$ . Let  $\nu$  be the involution on  $N$  which is restricted by the involution  $\mu \times 1$  on  $M \times RP(1)$ . Let  $g : N \rightarrow X$  and  $\alpha : N \rightarrow RP(1)$  be the compositions

$$N \hookrightarrow M \times RP(1) \xrightarrow{\pi_1} M \xrightarrow{f} X$$

and 
$$N \hookrightarrow M \times RP(1) \xrightarrow{\pi_2} RP(1),$$
 respectively.

We have an equivariant bundle map  $\bar{\alpha} : (\det \tau_N, \varepsilon \det d\nu) \rightarrow (\xi_1, 1)$  which covers  $\alpha$ . We can see this as follows. The normal bundle of  $RP(2r) \subset RP(2r+1)$  is  $\xi_{2r}$ . Let  $\nu_N$  be the normal bundle of  $N \subset M \times RP(1)$ . We then have an equivariant bundle isomorphism  $(\nu_N, d(\mu \times 1)) \cong (\det \tau_M \hat{\otimes} \xi_1, \varepsilon \det d\mu \hat{\otimes} 1)$  on  $N$ . Therefore,

$$(\tau_N \oplus (\det \tau_M \hat{\otimes} \xi_1), d\nu \oplus (\varepsilon \det d\mu \hat{\otimes} 1)) \cong (\tau_M \times \theta^1, d\mu \times 1) \text{ on } N,$$

where  $\theta^1$  is the trivial line bundle over  $RP(1)$ . Taking  $\det$  and tensoring  $(\det \tau_M \hat{\otimes} \xi_1, \det d\mu \hat{\otimes} 1)$  on both sides, we have  $(\det \tau_N, \varepsilon \det d\nu) \cong (M \times \xi_1, \mu \times 1)$  on  $N$ , since, in general, if  $(\eta, \bar{\sigma})$  is a line bundle over  $B$  with involution  $\bar{\sigma}$ ,  $(\eta \otimes \eta, \bar{\sigma} \otimes \bar{\sigma}) \cong (B \times R^1, \sigma \times 1)$ ,  $\sigma$  the involution covered by  $\bar{\sigma}$ . This implies that the desired  $\bar{\alpha}$  exists. By the above, a 4-tuple  $(N, \nu, g, \alpha)$  represents the class in  $\hat{\mathfrak{M}}_*^s(X, A, \tau)$ . We then define  $\Phi[M, \mu, f] = [N, \nu, g, \alpha]$ .

We prepare the following definitions and a Lemma for the proof of  $\Phi F = id$ . Let  $\kappa : RP(3) \rightarrow RP(3)$  be the diffeomorphism sending homogeneous coordinates  $[x_0, x_1, x_2, x_3] \in RP(3)$  into  $[x_0 + x_0, x_0 + x_1, x_0 + x_2, x_0 + x_3] \in RP(3)$ . Then  $\kappa$  is homotopic to the identity of  $RP(3)$ . We set

$$H = \{([x_0, x_1], [y_0, y_1]) \in RP(1) \times RP(1) \mid x_0 y_0 + x_1 y_1 = 0\},$$

and 
$$RP(2) = \{[x_0, x_1, 0] \in RP(3)\}.$$

**Lemma 4.** *Let  $M$  be a manifold and  $\alpha : M \rightarrow RP(1)$  be a differentiable map. Then the composition  $\theta = \kappa \circ \varphi \circ (\alpha \times 1) : M \times RP(1) \xrightarrow{\alpha \times 1} RP(1) \times RP(1) \xrightarrow{\varphi} RP(3) \xrightarrow{\kappa} RP(3)$  is transverse regular on  $RP(2)$ .*

*Proof.*  $\alpha \times 1$  is transverse regular on  $H$  (see Stong [6] p 152).  $\kappa \varphi$  is also transverse regular on  $RP(2)$ , and  $\kappa \varphi(H) \subset RP(2)$ . Then  $\theta$  is transverse regular on  $RP(2)$ .

For a given  $[M, \mu, f, \alpha] \in \mathfrak{M}_*^s(X, A, \tau)$ , we may construct a representative  $(N, \nu, g, \beta)$  of  $\Phi[M, \mu, f]$  by  $\theta = \kappa \circ \varphi \circ (\alpha \times 1)$ , i.e.,  $N = \theta^{-1}(RP(2))$ . Let  $\sigma$  be the involution on  $RP(1)$  sending  $[x_0, x_1]$  into  $[-x_1, x_0]$ . Then  $N = \{(m, \sigma\alpha(m)) \in M \times RP(1)\}$ , and  $(N, \nu, g, \beta) = (M, \mu, f, \sigma\alpha)$  by the diffeomorphism  $N \rightarrow M$  sending  $(m, \sigma\alpha(m))$  to  $m$ .  $[M, \mu, f, \sigma\alpha] = [M, \mu, f, \alpha]$  in  $\hat{\mathfrak{M}}_*^s(X, A, \tau)$ , since  $\sigma$  is homotopic to the identity of  $RP(1)$ . This implies  $\Phi F = id$ .

We define homomorphisms  $\rho: \hat{\Omega}_*^+(X, A, \tau) \rightarrow \hat{\mathfrak{M}}_*^+(X, A, \tau)$  and  $\rho: \hat{\Omega}_*^-(X, A, \tau) \rightarrow \hat{\mathfrak{M}}_*^-(X, A, \tau)$  by  $\rho[M, \mu, f] = [M, \mu, f, c]$ , where  $c$  is the constant map such that  $c(M) = p \in RP(1)$  ( $p \neq RP(0)$ ).

We also define a homomorphism  $\partial: \hat{\mathfrak{M}}_*^+(X, A, \tau) \rightarrow \hat{\Omega}_*^+(X, A, \tau)$  of degree  $-1$  as follows. For a given class  $[M, \mu, f] \in \hat{\mathfrak{M}}_*^+(X, A, \tau)$ , there is an equivariant bundle map  $\bar{\alpha}: (\det \tau_M, \det d\mu) \rightarrow (\xi_r, 1)$  for large  $r$  such that the map  $\alpha$  covered by  $\bar{\alpha}$  is transverse regular on  $RP(r-1)$ . We set  $N = \alpha^{-1}(RP(r-1))$ , then  $N$  is orientable and its orientation is uniquely determined up to sign. The involution  $\mu|N$  on  $N$  preserves orientation by Lemma 3. Let  $T(N)$  be a tubular neighborhood of  $N$  in  $M$ , and  $W = M - \text{Int } T(N)$ . Then  $(W, \mu|W, f|W)$  is a bordism from  $2(N, \mu|N, f|N)$  to zero, if we nicely deform  $f$  by means of homotopy. We may then define the homomorphism  $\partial$  by sending  $[M, \mu, f]$  into  $[N, \mu|N, f|N]$ . We also define a homomorphism  $\partial: \hat{\mathfrak{M}}_*^-(X, A, \tau) \rightarrow \hat{\Omega}_*^-(X, A, \tau)$  of degree  $-1$  in the same way as the above but we replace  $\det d\mu$  by  $-\det d\mu$ .

We then obtain the exact triangles of the type of Wall.

**Proposition 6.** *The triangles*

$$\begin{array}{ccc} \hat{\Omega}_*^+(X, A, \tau) & \xrightarrow{2} & \hat{\Omega}_*^+(X, A, \tau) \\ \partial F \swarrow & & \swarrow \rho \\ \hat{\mathfrak{M}}_*^+(X, A, \tau) & & \end{array} \quad \begin{array}{ccc} \hat{\Omega}_*^-(X, A, \tau) & \xrightarrow{2} & \hat{\Omega}_*^-(X, A, \tau) \\ \partial F \swarrow & & \swarrow \rho \\ \hat{\mathfrak{M}}_*^-(X, A, \tau) & & \end{array}$$

are exact.

*Proof.* It is easy to see that  $\rho 2 = 0$  and  $\partial F \rho = 0$ .  $2\partial F = 0$  is already seen. In the below, let  $\varepsilon$  denote one of the signs  $+$  and  $-$ .

$\text{Ker } \rho \subset \text{Im } 2$ . If  $[M, \mu, f] \in \hat{\Omega}_*^\varepsilon(X, A, \tau)$  and  $\rho[M, \mu, f] = [M, \mu, f, c] = 0$ , there is a bordism  $(W, \nu, g, \beta)$  with boundary  $(M, \mu, f, c)$ . We equivariantly deform  $\beta$  to be transverse regular on  $RP(0)$ , keeping on  $M$  fixed, and set  $N = \beta^{-1}(RP(0))$ . Then  $(N, \nu|N, g|N)$  represents a class in  $\hat{\Omega}_*^\varepsilon(X, A, \tau)$ . A tubular neighborhood of  $N$  in  $W$  is of the form  $N \times [-1, 1]$ . We deform  $g$  so that  $g|N \times [-1, 1] = (g|N) \circ \pi_1$  on a tubular neighborhood  $N \times [-1, 1]$  of  $N$  in  $W$ . Then  $2(N, \nu|N, g|N)$  is bordant to  $(M, \mu, f)$  with a bordism  $(W - N \times (-1, 1), \nu, g)$ .

$\text{Ker } \partial F \subset \text{Im } \rho$ . If  $[M, \mu, f, \alpha] \in \hat{\mathfrak{M}}_*^\varepsilon(X, A, \tau)$  and  $\partial F[M, \mu, f, \alpha] = [N, \mu|N, f|N] = 0$ , there is a bordism  $(W, \nu, g)$  with boundary  $(N, \mu|N, f|N)$ . Let  $f$  deform so that  $f|N \times [-1, 1] = (f|N) \circ \pi_1$  on a tubular neighborhood  $N \times [-1, 1]$  of  $N$  in  $M$ . Let  $V$  be the manifold formed from  $M \times [-1, 1]$  and  $W \times [-1, 1]$  by identifying a tubular neighborhood  $(N \times 1) \times [-1, 1]$  of  $N \times 1$  in  $M \times 1$  with the submanifold  $N \times [-1, 1]$  of  $W \times [-1, 1]$ . Define an involution  $\sigma$  on  $V$  by  $\sigma = \mu \times 1$  on  $M \times [-1, 1]$  and  $\sigma = \nu \times 1$  on  $W \times [-1, 1]$ , and

an equivariant map  $h: (V, \sigma) \rightarrow (X, \tau)$  by  $h = f\pi_1$  on  $M \times [-1, 1]$  and  $h = g\pi_1$  on  $W \times [-1, 1]$ . Also define  $L = (M \times 1 - (N \times 1) \times (-1, 1)) \cup W \times \{-1, 1\}$ . Then  $(L, \sigma|L, h|L)$  represents a class in  $\hat{\Omega}_*^e(X, A, \tau)$ . We then have  $\rho[L, \sigma|L, h|L] = [M, \mu, f]$ .

$\text{Ker } 2 \subset \text{Im } \partial F$ . If  $[M, \mu, f] \in \hat{\Omega}_*^e(X, A, \tau)$  and  $2[M, \mu, f] = 0$ , there is a bordism  $(W, \nu, g)$  with boundary  $2(M, \mu, f)$ , i.e.,  $\partial W$  contains two copies  $M_{-1}$  and  $M_1$  of  $M$ . Let  $[-1, 1]$  be a neighborhood of  $RP(0)$  in  $RP(1)$  with  $RP(0) = 0 \in [-1, 1]$ . We may obtain an  $RP(1)$ -structure  $\alpha$  of  $W$  such that  $\alpha(W) = RP(1) - (-1, 1)$ ,  $\alpha(M_{-1}) = -1$ ,  $\alpha(M_1) = 1$ , and  $\bar{\alpha} \circ \varepsilon \det d\nu = \bar{\alpha}$ ,  $\bar{\alpha}$  a bundle map covering  $\alpha$ . Let  $L$  be the manifold formed from  $M \times [-1, 1]$  and  $W$  by identifying  $M \times (-1)$  and  $M \times 1$  with  $M_{-1}$  and  $M_1$ , respectively. We may also obtain a desirable equivariant  $RP(1)$ -structure  $\beta$  of  $L$  such that  $\beta$  is the projection to the neighborhood  $[-1, 1]$  of  $RP(0)$  on  $M \times [-1, 1]$  and  $\beta = \alpha$  on  $W$ . Define an involution  $\sigma$  on  $L$  by  $\sigma = \mu \times 1$  on  $M \times [-1, 1]$  and  $\sigma = \nu$  on  $W$ , and an equivariant map  $h: (L, \sigma) \rightarrow (X, \tau)$  by  $h = f\pi_1$  on  $M \times [-1, 1]$  and  $h = g$  on  $W$ . Then  $(L, \sigma, h, \beta)$  represents a class in  $\hat{\mathfrak{M}}_*^e(X, A, \tau)$ , and  $\partial F[L, \sigma, h, \beta] = [M, \mu, f]$ , since  $\beta$  is transverse regular on  $RP(0)$ . The Proposition thus follows.

REMARK. In the special case  $(X, A, \tau) = (\text{pt}, \phi, 1)$ , from the exact triangles, we have the exact sequences  $\Omega_*(Z_2) \xrightarrow{2} \Omega_*(Z_2) \xrightarrow{F} \mathfrak{N}_*(Z_2)$  in the notation of Conner-Floyd [4], and  $0 \rightarrow \Omega_*^-(Z_2) \xrightarrow{F} \mathfrak{N}_*(Z_2)$  in which  $\Omega_*^-(Z_2)$  is the cobordism group of fixed-point free orientation-reversing involutions.

Being given a class  $[M, \mu, f] \in \hat{\mathfrak{N}}_*^e(X, A, \tau)$ , we have a classifying map  $\alpha: M \rightarrow RP(r)$  of  $\det \tau_M$  for large  $r$  such that  $\alpha$  is transverse regular on  $RP(r-2)$  and  $\alpha\mu = \alpha$ . Then we have a homomorphism  $d: \hat{\mathfrak{N}}_*^e(X, A, \tau) \rightarrow \hat{\mathfrak{N}}_*^e(X, A, \tau)$  of degree  $-2$  which sends  $[M, \mu, f]$  into  $[N, \mu|N, f|N]$ , where  $N = \alpha^{-1}(RP(r-2))$ .

**Proposition 7.** *The sequences*

$$\begin{aligned} 0 &\longrightarrow \hat{\mathfrak{M}}_*^+(X, A, \tau) \xrightarrow{F} \hat{\mathfrak{N}}_*^e(X, A, \tau) \xrightarrow{d} \hat{\mathfrak{N}}_*^e(X, A, \tau) \longrightarrow 0, \\ 0 &\longrightarrow \hat{\mathfrak{M}}_*^-(X, A, \tau) \xrightarrow{F} \hat{\mathfrak{N}}_*^e(X, A, \tau) \xrightarrow{d} \hat{\mathfrak{N}}_*^e(X, A, \tau) \longrightarrow 0 \end{aligned}$$

*are exact.*

Combining these exact sequences with the exact triangles in Proposition 6, we obtain the exact triangles of the type of Dold.

**Proposition 8.** *The triangles*

$$\begin{array}{ccc} \hat{\Omega}_*^+(X, A, \tau) \oplus \hat{\mathfrak{Y}}_*^+(X, A, \tau) & \xrightarrow{(2, 0)} & \hat{\Omega}_*^+(X, A, \tau) \\ & \swarrow (\partial, d) \quad \searrow F & \\ & \hat{\mathfrak{Y}}_*^+(X, A, \tau) & \end{array}$$

and

$$\begin{array}{ccc} \hat{\Omega}_*^-(X, A, \tau) \oplus \hat{\mathfrak{Y}}_*^-(X, A, \tau) & \xrightarrow{(2, 0)} & \hat{\Omega}_*^-(X, A, \tau) \\ & \swarrow (\partial, d) \quad \searrow F & \\ & \hat{\mathfrak{Y}}_*^-(X, A, \tau) & \end{array}$$

are exact.

Proof of Proposition 7.  $F$  is monic by Proposition 5.  $dF=0$  is easy, for if  $[M, \mu, f, \alpha] \in \hat{\mathfrak{Y}}_*^e(X, A, \tau)$ , a representative  $(N, \mu|N, f|N)$  of  $dF[M, \mu, f, \alpha]$  is constructed by  $\alpha: M \rightarrow RP(1)$ , so  $N$  is empty.

$\text{Ker } d \subset \text{Im } F$ . If  $[M, \mu, f] \in \hat{\mathfrak{Y}}_*^e(X, A, \tau)$  and  $d[M, \mu, f] = [N, \mu|N, f|N] = 0$ , there is a bordism  $(W, \nu, g)$  with boundary  $(N, \mu|N, f|N)$ . There is an equivariant bundle map  $\bar{\alpha}: (\det \tau_M, \varepsilon \det d\mu) \rightarrow (\xi_r, 1)$ , for sufficiently large  $r$ , such that the map  $\alpha$  covered by  $\bar{\alpha}$  is transverse regular on  $RP(r-1)$  and  $RP(r-2)$ . We set  $L = \alpha^{-1}(RP(r-1))$  and  $N = \alpha^{-1}(RP(r-2))$ , then we obtain equivariant bundle isomorphisms  $(\nu(N \subset L), d\mu) \cong (\det \tau_M, \varepsilon \det d\mu)|N \cong (\det \tau_N, \varepsilon \det d(\mu|N))$ , where  $\nu(N \subset L)$  is the normal bundle of  $N \subset L$ . Since  $r$  is large, we have an equivariant bundle map  $\bar{\beta}: (\det \tau_W, \varepsilon \det d\nu) \rightarrow (\xi_{r-2}, 1)$  which is compatible with  $\bar{\alpha}$  on  $N$  through the above bundle isomorphism. The disc bundle  $D(\xi_{r-2})$  associated to  $\xi_{r-2}$  may be considered as a tubular neighborhood of  $RP(r-2)$  in  $RP(r-1)$ . Therefore we may consider  $\bar{\beta}: D \det \tau_W \rightarrow RP(r-1)$ . Let  $(\varphi, \lambda)$  be the induced bundle  $\varphi$  with the induced involution  $\lambda$  over  $D \det \tau_W$  from  $(\xi_{r-1}, 1)$  by  $\bar{\beta}$ . Then we have  $(\varphi, \lambda)|(D \det \tau_N, \varepsilon \det d(\mu|N)) \cong (\nu(L \subset M), d\mu)|(D\nu(N \subset L), d\mu)$ .

Let  $\bar{M}$  be the manifold formed from  $M \times [0, 1]$  and  $D(\varphi)$  by identifying the appropriate part of  $D(\varphi)$  with that of the tubular neighborhood of  $L \times 1$  in  $M \times 1$

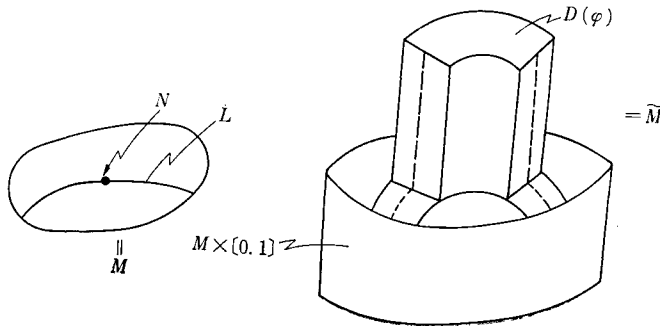



by the above isomorphism. Define an involution  $\tilde{\mu}$  on  $\tilde{M}$  by  $\tilde{\mu}|M \times [0, 1] = \mu \times 1$  and  $\tilde{\mu}|D(\varphi) = \lambda$ , and an equivariant map  $\tilde{f}: (\tilde{M}, \tilde{\mu}) \rightarrow (X, \tau)$  by  $\tilde{f}|M \times [0, 1] = f\pi_1$  and  $\tilde{f}|D(\varphi) = g\pi\pi'$ ,  $\pi$  and  $\pi'$  the appropriate bundle projections. We set  $M' = \partial\tilde{M} - \text{Int}(M \times 0 \cup \partial M \times [0, 1] \cup D(\varphi)|V)$ ,  $V =$  the closure of  $\partial W - N$ ,  $\mu' = \tilde{\mu}|M'$ , and  $f' = \tilde{f}|M'$ . Then  $(M', \mu', f')$  is bordant to  $(M, \mu, f)$  with a bordism  $(\tilde{M}, \tilde{\mu}, \tilde{f})$  in  $\hat{\mathfrak{R}}_*(X, A, \tau)$ .

Now nothing remains but to see that  $M'$  has a desirable  $RP(1)$ -structure. There exists an equivariant bundle map  $\bar{\gamma}: (\det \tau_{\tilde{M}}, \varepsilon \det d\tilde{\mu}) \rightarrow (\xi_r, 1)$  such that the map  $\gamma$  covered by  $\bar{\gamma}$  is the composition  $\alpha\pi_1$  on  $M \times [0, 1]$  and  $\bar{\beta}: D(\varphi) \rightarrow D(\xi_{r-1}) \subset RP(r)$  on  $D(\varphi)$ ,  $\bar{\beta}$  the bundle map covering  $\beta$ . For this is clear on  $M \times [0, 1]$ , while on  $D(\varphi)$ , we have  $(\det \tau_{D(\varphi)}, \varepsilon \det d\lambda) \cong \pi^*(\varphi, \lambda)$  where  $\pi: D(\varphi) \rightarrow D \det \tau_W$  is the bundle projection. We then obtain an equivariant bundle map  $\bar{\gamma}': (\det \tau_{M'}, \varepsilon \det d\mu') \rightarrow (\xi_r, 1)$  such that the map  $\gamma'$  covered by  $\bar{\gamma}'$  is the restriction of  $\gamma$  to  $M'$ . Let identify the associated disc bundle  $D\nu(N \subset L)$  of  $\nu(N \subset L)$  with a tubular neighborhood of  $N$  in  $L$ , and let  $S \det \tau_W$  be the associated sphere bundle of  $\det \tau_W$ . Let  $L'$  be the submanifold of  $M'$  which is the union of  $L - \text{Int}(D\nu(N \subset L))$  and  $S \det \tau_W$ , i.e.,  $L'$  is the part of the dotted lines in the above figure. Then  $L' = \gamma'^{-1}(RP(r-1))$ . Since  $RP(r) - RP(r-1)$  is contractible, we may equivariantly homotope  $\gamma'$  to the composition  $M' \xrightarrow{c} T\nu(L' \subset M') \xrightarrow{T(\gamma'|L')} T\xi_{r-1} = RP(r)$ , where  $T\nu(L' \subset M')$  and  $T\xi_{r-1}$  are the Thom spaces,  $c$  is the collapsing, and  $T(\gamma'|L')$  is induced from a bundle map covering  $\gamma'|L'$ . Since  $RP(r-1) - RP(r-2)$  is also contractible, we may equivariantly homotope  $\gamma'|L'$  to a point map. So  $T(\gamma'|L')$  is homotoped to  $T\nu(L' \subset M') \rightarrow T(\xi_{r-1}| \text{one pt}) = RP(1)$ . This implies  $M'$  has a desirable  $RP(1)$ -structure.

Finally,  $d$  is epic. Let  $[M, \mu, f] \in \hat{\mathfrak{R}}_*(X, A, \tau)$ . Let  $V_0 = P \det \tau_M \xrightarrow{\pi_0} M$ ,  $V_1 = P(\det \tau_M \oplus \theta^1) \xrightarrow{\pi_1} M$ , and  $V_2 = P(\det \tau_M \oplus \theta^2) \xrightarrow{\pi_2} M$  be the projective space bundles associated to  $\det \tau_M$ ,  $\det \tau_M \oplus \theta^1$  and  $\det \tau_M \oplus \theta^2$ , respectively, where  $\theta^1$  and  $\theta^2$  are the trivial bundles over  $M$  of dimension 1 and 2, respectively. Then  $V_0 \subset V_1 \subset V_2$  is a sequence of submanifolds with involution  $\nu_0 = P \det d\mu$ ,  $\nu_1 = P(\det d\mu \oplus 1)$  and  $\nu_2 = P(\det d\mu \oplus 1)$ , respectively. Let  $\alpha_0: (V_0, \nu_0) \rightarrow (RP(r), 1)$  be the classifying map of  $\det \tau_{V_2}|V_0$ . Since the normal bundle of  $V_0 \subset V_1$  is the canonical line bundle over  $V_0$ , we may extend  $\alpha_0$  to a map from a tubular neighborhood of  $V_0$  in  $V_1$  to that of  $RP(r)$  in  $RP(r+1)$ . Further, we may extend it to a classifying map  $\alpha_1: (V_1, \nu_1) \rightarrow (RP(r+1), 1)$  of  $\det \tau_{V_2}|V_1$  which is transverse regular on  $RP(r)$  and  $\alpha_1^{-1}(RP(r)) = V_0$ , since  $RP(r+1) - RP(r)$  is contractible. (See Wall [9] for detail.) Exactly as before, we may extend  $\alpha_1$  to a classifying map  $\alpha_2: (V_2, \nu_2) \rightarrow (RP(r+2), 1)$  of  $\det \tau_{V_2}$  which is transverse regular on  $RP(r)$  and  $\alpha_2^{-1}(RP(r)) = V_0$ . Then we have  $d[V_2, \nu_2, f\pi_2] = [V_0, \nu_0, f\pi_0]$

for  $[V_2, \nu_2, f\pi_2] \in \mathfrak{H}_*^{\hat{\sigma}}(X, A, \tau)$ , and  $[V_0, \nu_0, f\pi_0] = [M, \mu, f]$  by  $\pi_0$ . The Proposition thus follows.

OSAKA UNIVERSITY

---

### References

- [ 1 ] M.F. Atiyah: *Bordism and cobordism*, Proc. Cambridge Philos. Soc. **57** (1961), 200–208.
- [ 2 ] G.E. Bredon: *Equivariant Cohomology Theories*, Lecture Notes in Math. 34, Springer-Verlag, 1967.
- [ 3 ] P.E. Conner: *Lectures on the Action of a Finite Group*, Lecture Notes in Math. 73, Springer-Verlag, 1968.
- [ 4 ] P.E. Conner and E.E. Floyd: *Differentiable Periodic Maps*, 1964, Springer-Verlag.
- [ 5 ] A. Dold: *Structure de l'anneau de cobordisme  $\Omega$* , Bourbaki seminar notes, Paris, 1959–60.
- [ 6 ] R.E. Stong: *Notes on Cobordism Theory*, Princeton Univ. Press, 1969.
- [ 7 ] ———: *Bordism and involutions*, Ann. of Math. **90** (1969), 47–74.
- [ 8 ] C.T.C. Wall: *Determination of the cobordism ring*, Ann. of Math. **72** (1960), 292–311.
- [ 9 ] ———: *Cobordism exact sequences for differential and combinatorial manifolds*, Ann. of Math. **77** (1963), 1–15.

