

Overview of grid-connected two-stage transformer-less inverter design



Mohsen SHAYESTEGAN¹ 

Abstract This paper gives an overview of previous studies on photovoltaic (PV) devices, grid-connected PV inverters, control systems, maximum power point tracking (MPPT) control strategies, switching devices and transformer-less inverters. The literature is classified based on types of PV systems, DC/DC boost converters and DC/AC inverters, and types of controllers that control the circuit to ensure maximum power tracking and stabilization of load and input voltage. This is followed by the theoretical background of PV devices, an overview of MPPT controllers and common mode leakage current, and a detailed investigation of different inverter topologies regarding the ground leakage current. Furthermore, design principles of power converters, such as DC/DC boost converters, and single-phase inverters are discussed. The paper also discusses limitations and benefits in addition to the basic operating principles of several topologies. Finally, the proposed system is derived and its simulation results are discussed to offer the next generation of grid connected PV systems.

Keywords Transformer-less inverter, DC/DC boost converter, Maximum power point tracking (MPPT) controller, Grid connected photovoltaic (PV) system

CrossCheck date: 23 October 2017

Received: 29 November 2016 / Accepted: 24 October 2017 /
Published online: 29 January 2018
© The Author(s) 2018. This article is an open access publication

✉ Mohsen SHAYESTEGAN
mohsen_sh1361@hotmail.com

¹ Department of Electric, Electronic and system Engineering,
Faculty of Engineering and Built Environment, Universiti
Kebangsaan Malaysia, Bangi, Malaysia

1 Introduction

By the increasing growth in the population of the world, the demand for new energy sources is significantly increasing. Today, fossil fuel resources are the major energy sources used for generating electricity. These resources include petroleum, natural gas, coal, etc. [1], which also result in serious environmental pollution and contribute to global warming by releasing the harmful carbon dioxide into the atmosphere. In addition, such resources are non-renewable limited energy sources that cannot fulfill the ever increasing demand for energy.

Renewable sources of energy such as biomass, wave energy, wind power, hydroelectricity, and solar power could be alternative sources to replace fossil energy resources. Renewable resources provided for about 18% of global energy consumption in 2006 [2]. Wind power is currently widely used in the United States and Europe. It is installed capacity of over 100 GW and growing rate of over the 30% per annum. Photovoltaic industry could produce more than 2000 MW of electricity power in 2006 [2]. Because of their reliability and easy access to the energy source, photovoltaic systems have attracted much more attention than other technologies that use renewable energy sources. Advantages of photovoltaic (PV) systems outweigh their drawbacks. Some of these advantages are long life, low maintenance needs, ease of installation and no need for fuel; drawbacks are low output in cloudy days and high costs of initial setup [3]. The voltage generated by a PV cell is low (about 0.5 to 0.7 V); thus, it is necessary to connect a series of cells in a PV panel. In addition, the panels can be linked in parallel or in series to produce higher voltage with a greater current with same voltage, or the same current, respectively [4]. Generally, grid connected PV inverters can be divided into two groups: single

stage inverters and two stage inverters. Previous studies were mainly centered on single stage inverters, while present and future studies mainly focus on two stage inverters. In two stage inverters, a DC/DC converter connects the PV panel and the DC/AC inverter. The PV panel converts sunlight to DC electricity (for a PV panel with low output voltage, a DC/DC boost converter is used [5]); DC voltage can then be converted to AC voltage with a power electronics system (inverter).

In either grid-connected or stand-alone applications of such devices, DC voltage can be converted to AC voltage by a DC/AC inverter system [4]. Grid-connected or stand-alone, these devices are used in a wide range of systems today, from streetlights to space vehicles. They are used as an attempt to improve reliability, efficiency and cost [6].

In the past, galvanic isolation in photovoltaic grid-connected inverters was mainly realized through employing line frequency transformers between the photovoltaic system and the grid. These transformers were not only difficult to install, but also large and heavy. In addition, they increased system complexity and were inefficient due to several power stages [7, 8]. To solve the problems of efficiency, cost and size of inverters, transformer-less inverters were introduced. Removing the transformer causes a galvanic connection between the photovoltaic system and the power grid. Thus, the common mode leakage current may follow through the parasitic capacitors between photovoltaic system and ground [9]. This leakage current increases system losses and grid current harmonics and leads to serious unsafety [10]. Therefore, the common mode leakage current must be taken into account in designing transformer-less PV inverters.

The efficiency of a PV system is directly affected by the intensity of sun radiation and ambient temperature. In power applications, the efficiency of a PV systems needs be high if it is to deliver the power to the grid. Therefore, it is necessary to track the maximum power under changing surrounding conditions. In a two-stage inverter, the first stage – DC/DC boost converter –delivers maximum power to the second stage and regulates the DC-link voltage [11, 12]. There are various types of controllers, e.g., P&O, Fuzzy, Neural network, sliding mode controller etc., to track the maximum power in the first stage [13]. In the second stage, the controller system controls power stability and quality. In PV applications, good inverter controllers are essential for enhancing the inverter performance since the conversion process depends on control algorithms [14]. This paper reviews the literature on the design of grid-connected PV systems containing DC/DC boost converters, DC/AC inverters, and controllers used for converters and inverters.

2 Photovoltaic device

Several energy sources are available for energy conversion systems, including batteries, PV devices, fuel cells and wind generators. Each energy source is connected to its inverter through a specific integration technique; sometimes, additional devices and extra steps may also be needed. For instance, a wind turbine generator needs an extra AC/DC converter (e.g. rectifier) to connect to an inverter [15], since it generates an AC instead of a DC current. On the contrary, a PV panel creates DC power; thus, it can be linked to the inverter directly or through a DC/DC converter. Favorably, this will decrease the total cost [16]. Essentially, a PV cell has a semiconductor P-N junction diode cell that directly transforms light into electricity [17]. When sunlight hits common junctions of a p-n diode, comprising of photons, the electron system of the material absorbs the energy and produces electron-hole pairs (charge carriers). These are detached by the potential wall, generating a voltage that uses an external circuit to drive a current through, known as the photovoltaic effect [18]. Different cell arrangements, such as series-parallel, parallel and series create a PV module that has a specific power capacity [19].

Likewise, modules are linked in series-parallel arrangement to gain higher power capacity and make a panel or array [20]. The solar cell's output voltage is a function of the photocurrent that is contingent on the level of solar irradiation throughout the process [21].

Shortcomings of a PV device include low energy conversion efficiency and high cost of initial-installation [22–26]. The control system has an important role in a PV system that uses power converters, such as DC/DC converters and DC/AC inverters to safeguard the system's overall operation [27].

3 DC/DC power converter

DC/DC power converters are employed in PV systems to change the output voltage. Normally, a DC/DC converter is sequentially inserted between the load and the PV panel to gain the power available from the panel through tracking methods. It is useful for a PV system with unstable and fluctuating output. If the PV system uses both AC and DC converters, a DC-link capacitor can enhance the DC output voltage stability, and therefore, reduce the effect of fluctuation on the AC output [28]. DC converters may be boost converters (step-up), buck converters (step-down), or a combination of both, like CUK converters and buck-boost converters. Converter type may be selected based on the desired capacity or size of the output voltage



to provide the appropriate input voltage for the inverter with the dc voltage stabilization and regulation capability [29]. This is applicable for hybrid energy systems, grid-connected systems and standalone systems. DC/DC converter in such systems works with a maximum power operating algorithm so that the PV system generates more power. The performance of a converter varies based on the specific application.

4 DC/AC inverter

An inverter is a power electronic converter, which converts DC power to AC power [30] to generate a sinusoidal AC output with controllable frequency and magnitude [31]. Inverters are classified into two types: a voltage source inverter (VSI) is an inverter which is fed with constant voltage, while a current source inverter (CSI) is fed with constant current. Generally, CSIs are used for applications that need very high power AC motor drives. According to the aims, a single-phase VSI was used in this study.

The single-phase inverter involves power stage of two legs, a DC-link capacitor, and a DC input voltage source (VDC). The DC input voltage source is basically a constant voltage source that can be connected to the DC-link capacitor. DC input voltage level is determined by the inverter's specifications. For a power system, the dc input voltage level of a single-phase inverter should be greater than the peak voltage of the inverter's line-to-line AC output voltage. The capacitor's properties are important when there is a fluctuating input DC power, as is the case for a PV panel, to ensure that the DC-link voltage is kept stable during switching between power devices [32]. The DC-link capacitance must be sufficient enough to decrease the DC-link voltage ripple, in order to generate quality output power [33].

Switching devices is an important part of DC/AC conversion. Each leg has two insulated gate bipolar transistors (IGBTs) with anti-parallel diodes so that the legs never work simultaneously [30]. Switching device is selected based on the specific design of a system, e.g. switching speed and power capacity. Generally, MOSFET is chosen for supplying lower power capacity with fast switching speed, whereas IGBT is used for higher power capacity with medium switching speed [31].

5 Design of grid-tied PV inverter

The inverter in the grid-tied PV system acts as an interface between energy sources: the utility grid on one side and the PV module on the other. As the inverter

transforms DC power into AC power, it is in control of power quality that should be met as required by different standards. Based on the galvanic isolation between the grid and the PV module, the grid-tied PV inverters are grouped into isolated and non-isolated types. A high frequency transformer or a line frequency transformer can be used to observe the galvanic isolation that adjusts DC voltage of the converter [34–36]. Usually, this galvanic isolation is realized through a transformer that has a great effect on DC/AC efficiency of grid-connected PV systems [37]. In a grid connected PV system, the existence of galvanic isolation depends on the regulations of each country [38]. In countries, such as Italy and UK, it is a requirement and is implemented either by a high-frequency transformer on the DC side or by a low-frequency step-up transformer on the grid side, as shown in Fig. 1b, c.

Due to weight, size and cost problems, line frequency transformers are usually preferred to be removed when designing a new converter. Moreover, a high-frequency transformer requires numerous power stages, which makes it difficult to increase efficiency and reduce the costs [39].

On the other hand, in Spain and Germany galvanic isolation is not used if other technological solutions are employed to separate the electrical grid and the PV array. Figure 1a depicts a typical transformer-less PV system, which decreases installation complexity, weight cost and size of the whole system. One drawback of these systems is that DC currents may be produced in the injected AC current by the inverter because of the missing line-frequency transformer, causing overheating and failure [40, 41]. One of the advantages of these systems is 2% increase in the total efficiency [30, 42, 43].

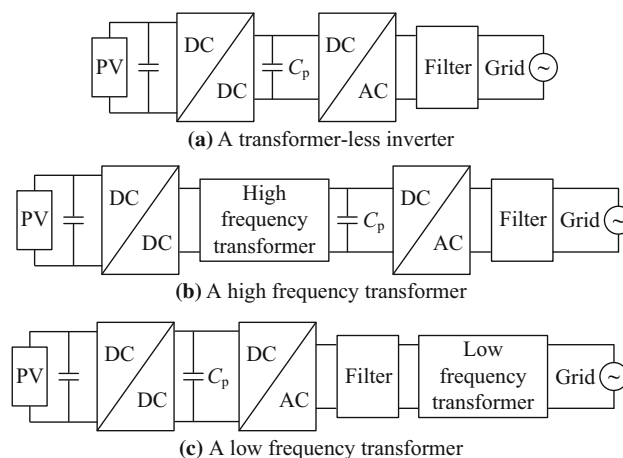

Fig. 1 Grid-connected PV system

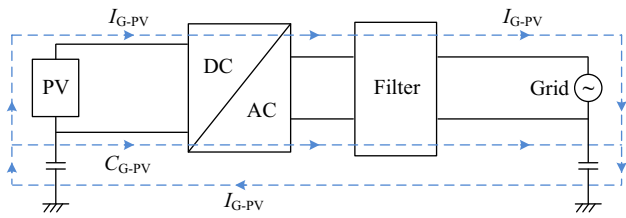

Fig. 2 Path of ground leakage current in transformer-less PV system

6 Leakage ground current

There is no galvanic isolation between the grid and PV array in a transformer-less topology. As such, the grid and the PV panels are directly linked, so the leakage ground currents, created through the potential fluctuations between the grid and the PV array, have a direct path [44]. The parasitic capacitance created between the grounded frame and surface of the PV are charged and discharged by these voltage fluctuations, shown as C_{G-PV} in Fig. 2.

A resonant circuit is formed by the parasitic capacitance and the DC lines that link the inverter to the PV array. Resonance frequency in this circuit depends on the length of DC cables and PV array size [45, 46]. According to the inverter topology, modulation strategy and PV panel structure, a ground current can flow in the body if panel surfaces are touched; if the current is higher than a certain level, it can result in a shock or lead to injury [69]. The blue intermittent line in Fig. 2 shows the path of the ground

current moving through the parasitic capacitance of the PV array.

Based on the VDE0126-1-1 standard, a residual current monitoring unit should be used to monitor secure operation of a grid-connected PV system. The LEM CT 0.2-P [47] is a commercial current sensor that has been studied by many scholars for potential use in ground leakage current measurement.

7 Transformer-less single phase inverters

7.1 Full H-bridge

Full H-bridge is commonly used in grid-connected photovoltaic inverters. It has 4 transistors, linked as shown in Fig. 3a.

Since many commercial inverters employ this topology together with a low frequency transformer, it is worth studying its use for transformer-less inverters. Unipolar PWM is the most commonly used modulation in this topology, since it offers several advantages compared to bipolar modulation, such as better efficiency or lower emission of electromagnetic interferences and lower current ripple at high frequencies [48]. Nevertheless, a high frequency common mode voltage of amplitude $V_{dc}/2$ is applied to the photovoltaic panels in unipolar PWM modulation, which produces a non-negligible leakage current

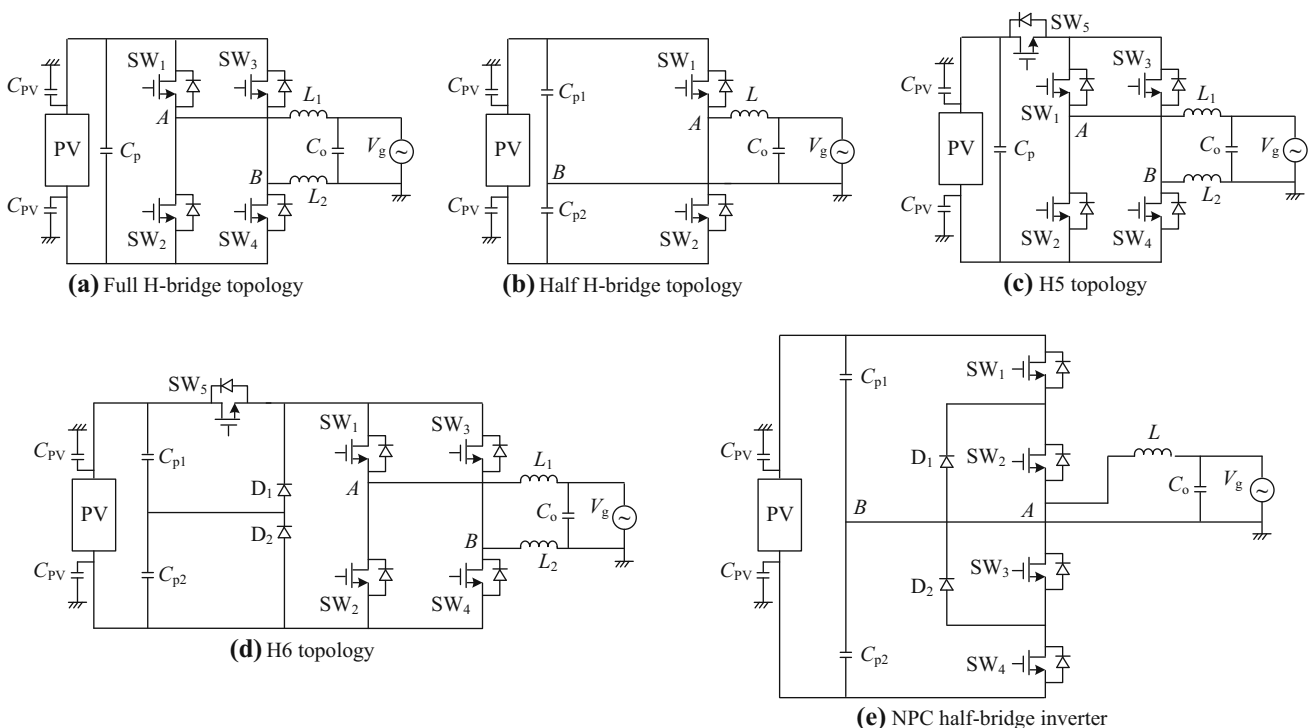

Fig. 3 Topology of inverters

due to the parasitic capacitance of photovoltaic panels. Thus, it is not recommended to use this modulation in transformer-less inverters [49]. In the full H-bridge photovoltaic inverter, the Bipolar PWM modulation is used to solve the problem of the leakage current. This eliminates high frequency components of the applied common-mode voltage to the panels [50]. The common mode voltage has only the low frequency component of the first harmonic and thus, leakage current is reduced [9, 46, 51]. However, gate signals of bridge transistors need to be synchronized so that peak leakage current is limited. Otherwise, leakage current might increase significantly [52]. Therefore, this topology is not suitable for transformer-less photovoltaic inverters, even when bipolar PWM modulation is used [53].

7.2 Half H-bridge

The half H-bridge topology involves a capacitive divider coupled with the photovoltaic module and 2 transistors shown in Fig. 3b.

The grid neutral wire connection to the capacitive divider midpoint warrants a more or less constant voltage that inhibits leakage current through the module's parasitic capacitance [54]. The half H-bridge uses half of the semiconductors, which makes it simpler and less costly than the H-bridge topology [55]. However, serious disadvantages limit its use. For example, the switches need to support twice the voltage required in full H-bridge topology, the output waveform has only two levels, and the output current is so distorted that produces high electromagnetic interference emissions [54, 56]. Therefore, it needs higher blocking voltage power transistors that in turn increase the switching losses.

7.3 H5 topology

H5 topology was first introduced by the SMA [57]. Compared to the full-bridge, this topology requires only one extra transistor. This means that, the photovoltaic panels are disconnected from the grid during current free-wheeling periods to inhibit switching of frequency ripple in panel poles' the voltage to ground, keeping a nearly constant common mode voltage. The H5 topology shown in Fig. 3c uses a full-bridge consisting of a DC-bypass SW_5 switch and 4 other switches: SW_1 , SW_2 , SW_3 and SW_4 .

SW_1 and SW_2 switches work at grid frequency, while SW_3 , SW_4 and SW_5 function at high frequency. SW_5 is open during current free-wheeling period, detaching the inverter of full H-bridge from photovoltaic panels. SW_1 closes the free-wheeling path, by SW_3 and SW_1 inverse diode for the negative half-cycle and the SW_3 inverse diode for the positive half-cycle of electrical grid. H5

transformer-less inverter topology is highly efficient, especially at partial load [58]. It only requires one extra transistor compared to the full H-bridge topology. Nevertheless, conduction losses may increase in case of a low-quality semiconductor, since the transistor is in series with the full H-bridge inverter [59]. Currently, this topology is used by some inverters in the market, particularly those from branded patent, as an alternative to transformer-less photovoltaic inverters [50].

7.4 H6 topology

Full-bridge with DC bypass (FB-DCBP) topology adds a bidirectional clamping branch and two switches to the FB topology shown in Fig. 3d [60]. The clamping branch has two diodes and a capacitive divider that clamp half of the DC input voltage to the CM voltage. SW_1 and SW_4 are commutated in anti-parallel to SW_2 and SW_3 with line frequency, depending on whether the grid voltage is in negative or positive half period. D_1 or D_2 (diodes of SW_1 and SW_2) work during freewheeling mode depending on whether freewheeling path potential is lower or higher than half of the DC link voltage. Effectiveness of leakage current removal in this topology depends only on the turn-on speed of the clamping diodes. The main disadvantage of FB-DCBP topology is conduction losses due to the flow of inductor current through four switches in the active mode [60].

7.5 NPC half-bridge

The NPC half-bridge is a single-phase version of the multilevel topology for high-power motor-drive uses [61]. It has been lately introduced as an alternative in designing photovoltaic inverters. It has a branch with two clamping diodes and 4 transistors shown in Fig. 3e.

The diodes provide a free-wheeling path for the output current, resulting in state of 0 V output voltage [50]. The NPC half-bridge topology functions in the same way as the half-bridge, but it has less current ripple, better efficiency and a constant common mode voltage [56], inhibiting leakage currents. The NPC topology's voltage derivative and performance are also similar to full-bridge topology with unipolar PWM modulation that is three-level output inverter voltage. Therefore, the performance of both the converter and the output filter is comparable to a unipolar PWM modulated full-bridge [51].

This topology, however, has a number of disadvantages. It requires a high input voltage, several power semiconductors and a high capacity bank of capacitors [46, 62], which makes twice the full-bridge input voltage [50]. Another problem is the transient overvoltage in internal transistors because of lack of parallel capacitors [63]. This

Table 1 Major characteristics of different transformer-less topologies

Methods	Leakage current	Input voltage (V)	Efficiency
Half H-bridge [55]	Moderate	800	—
Full H-bridge [52]	Moderate	400	+
NPC [61]	Very low	400	++
Dual-buck [49]	Low	400	++++
FC [95]	Very low	400	++++
H5 [96]	Low	400	+++
Single-buck [97]	Moderate	400	+++
HB-ZVR [98]	Moderate	400	+
HERIC [99]	Low	400	+++
H6 [100]	Moderate	800	++

problem, however, can be solved by a snubber circuit. Moreover, not the same level of power loss occurs in all of the semiconductors [64]. Table 1 shows the efficiency, leakage current and input voltage of several previously validated methods. Nevertheless, determining the best method is difficult because each method has its own strengths and weaknesses.

8 Control structures for grid connected PV systems

Sinusoidal current is injected into the grid by DC/AC inverters. The inverter transforms the DC power into AC power for grid injection. Control is an important part of the system PV linked to the grid. Two types of controllers are used in these systems: ① MPP controller that mainly extracts the maximum power from the PV module; ② Inverter controller that controls DC-link voltage, active and reactive power fed into the grid, grid synchronization and the injected power.

The control structure has two controllers that work in two cascaded loops: an external voltage loop that regulates the DC-link voltage, and a fast internal current loop that controls the grid current or voltage. The DC-link voltage controller balances the system’s power flow. Typically, the external controller is intended to do optimal control and ensure the stability of systems with slow dynamics. The stability time in this loop should be 5–20 times more than that in the internal current loop. The external and internal loops work separately; therefore, the transfer role of the current control loop is not considered in the design of the voltage controller [35, 65–67]. Sometimes, the controller uses a cascaded DC-link voltage loop with an internal power loop rather than a current loop. In this way, the injected current is controlled indirectly. Figure 4 shows the

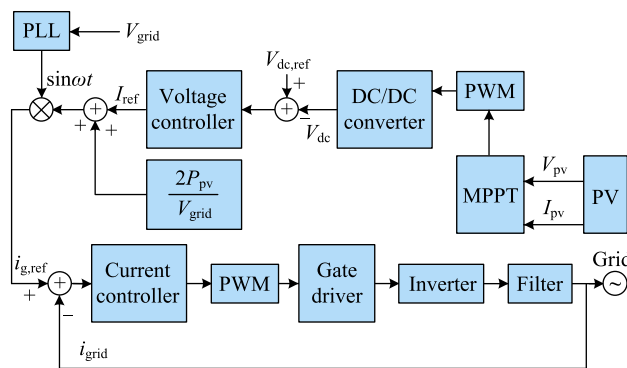

Fig. 4 Control structure topology for single phase two stage inverter

control structure of a single phase inverter with a DC/DC converter, as introduced by Ciobotaru et al [68]. A current-controlled H-bridge PWM inverter with low-pass output filters is the most popular control structure for the DC/AC grid converter.

8.1 MPPT control

To get the maximum power in the inverter, a maximum power point tracker (MPPT) is needed. This is achieved by regulating the operating current and voltage of the converter so that it remains close to MPP all the time. In MPPT, voltage and current of the PV array are detected by voltage and current sensors at a particular sampling cycle, respectively [69]. The values are then entered in a MPPT block that calculates the MPP. The MPP provides the reference values for voltage and current, which are transformed to a power value that should match the calculated value. If there is a difference, the converter’s duty cycle is adjusted. When the reference value and the measured power match, it means that the array is already working at maximum power. The converter is typically based on the standard non-isolated, boost or buck–boost topology. The most important advantage of the MPPT is its ability to find the MPP as fast and efficiently as possible. A number of algorithms can be used for the MPPT [70–72], including the incremental conductance, perturb and observe, constant voltage and parasitic capacitance. Incremental conductance and perturb and observe algorithms are the most common.

Perturb and observe (P&O) method has attracted much attention because of its simplicity [13, 72]. In this method, the system current is disturbed by a perturbation in the duty cycle of the converter and consequently, it perturbs the PV system voltage.

As it can be seen in Fig. 5, clearly when the power operating on the left side needs to increase the voltage, the one operating on the right side needs to decrease the voltage. Therefore, when the power increases, the next duty

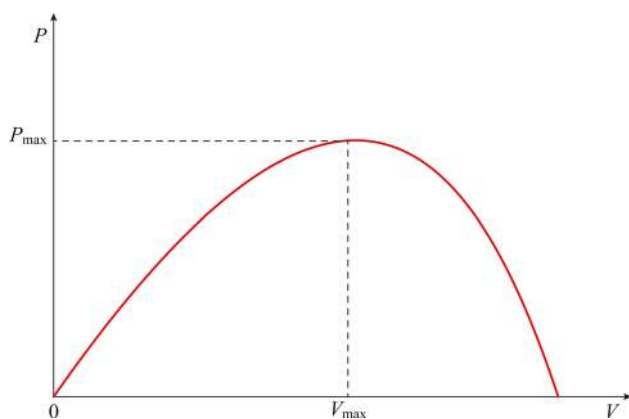

Fig. 5 Characteristic of PV panel power curve

cycle should remain constant to obtain the maximum power point, while when the power decreases the duty cycle should be reversed to reach the MPP. This process is iterated until the system reaches the MPP. Owing to the ease of application and simplicity of the P&O technique, it is the most popular method in practice [13, 72].

This method has two major problems: ① determining the convergence rate of the tracking MPP; ② determining the oscillation amplitude. For large perturbations, the MPP is tracked faster, but causes higher oscillation amplitude. For small perturbations, the convergence rate is reduced, but the oscillation around the MPP is decreased as well. This results in a decline in steady oscillations around the MPP. To solve this, modified versions of P&O have been developed [73].

Various MPPT methods have been proposed [73–82], each with its own pros and cons, and it is quite difficult to decide which method to use. In fact, the decision depends on the specific application. For example, in solar vehicles the priority is fast convergence to the MPP. In this case, the intelligent methods are the most suitable option. In the case of space satellites, where reliability and performance of the MPPT are the most important factors and MPP tracking needs to be done almost in real-time, Hill-climbing methods such as P&O are the best choice. Characteristics of different MPPT techniques, i.e. complexity, convergence speed, and PV module dependency, are summarized in Table 2.

8.2 DC/AC inverter control

To control the output current, a control system is required that can automatically regulate the duty cycle. The DC/AC controller has two control loops: the external DC-bus voltage control loop, and the internal current control loop. The internal control loop controls sudden changes in AC current to maintain a sinusoidal current. A PLL sinusoidal signal reference generates the reference current (I_{ref}),

Table 2 Major characteristics of different MPPT methods

Method	True MPPT	Convergence speed	Tuning	Complexity
P&O [73]	YES	Fast	NO	Medium
IC [74]	YES	Varies	YES	High
Fuzzy [75]	YES	Fast	YES	High
NN [76]	YES	Fast	YES	Medium
GA [77]	YES	Fast	YES	Low
Voc [78]	NO	Medium	YES	Medium
Isc [79]	NO	Medium	NO	Low
DC-link [80]	NO	Medium	YES	High
ESC [81]	YES	Fast	NO	High
Temp [82]	YES	Medium	YES	Low

which synchronizes the grid voltage with the output inverter current [68, 83, 84]. The amplitude current is controlled by the external voltage loop. The external loop controls the DC-bus voltage (V_{dc}). This voltage should be limited; however, controlling V_{dc} is required for controlling the power fed into the grid.

9 Power quality

An important consideration in power quality is that, according to the standards (e.g. IEEE Std 519-1992) the output waveform should obtain low level of THD. The power conversion process can endanger quality [85]. Power quality consists of current quality and voltage quality [86]. Current and voltage quality are related to deviations from the standards [87]. A single-frequency sine wave of constant frequency and amplitude has perfect quality [87]. Harmonics, voltage flickers, voltage dips and noise are examples of problems that negatively affect power quality. The most important of these problems is harmonics [86], which can cause decreased volt-ampere capacity, equipment overheating, current and voltage waveform distortion and increased losses [88]. The harmonic level is determined by the THD value, which is a measure of similarity of shape between a waveform and its main mechanisms [30]. Inverter output involves harmonics that might be harmful to the loads. Therefore, the inverter must use filters prior to sending power to the loads [89]. In addition, in inverters, and generally power converters, the quality of DC input voltage has an important role in the quality of the output waveform [90]. Accordingly, one way of enhancing the quality of the output waveform is filtering the DC input voltage. Generally, the second order low-pass LC filter is used for this purpose. It is simple and inexpensive and can decrease the output waveform's higher harmonics components.

10 Grid synchronization techniques

Traditionally, synchronization of grid connected DC/AC inverters is done by duplicating the grid voltage in a way that grid voltage and output current reference are in the same phase [91]. This technique is simple; however, it has a number of disadvantages. It transfers the grid transients and distortions to distort the output current, which is undesirable for grid-connected uses. Furthermore, this method does not enable inverters to control reactive power flow. Single phase grid connected inverters generally use phase locked loops (PLL). Stationary frame PLLs do not need extra signals, and therefore, they only take the grid voltage as input. A typical stationary frame PLL uses a voltage controlled oscillator (VCO), a loop filter (LF) and a sinusoidal multiplier phase detector (PD). Thacker et al. modified the stationary frame PLLs by adding extra state feedback terms [92], which improved immunity to input disturbances and noise, increased synchronization speed, and eliminated the double-line frequency ripple term created by the PD.

11 Requirements of grid

Grid-connected PV systems should adhere to certain standards specific to each country, such as EN 50106, IEEE 1547.1-2005, IEC61727 and VDE0126-1-1. These standards deal with issues like individual harmonic current levels, total harmonic distortion (THD), leakage current, injected DC current level, range of frequency and voltage for regular operation, detection of islanding operation, power factor (PF), automatic reconnection, synchronization and grounding of the system [35, 93]. In Germany, the VDE-0126-1-1 standard is the only one addressing leakage current levels or faults in transformer-less PV inverters. According to this standard, when the RMS of leakage current is above 30 mA, it takes 0.3 s to disconnect the inverter from the grid. Table 3 shows RMS values of the leakage current or faults and their disconnection times.

Table 3 Leakage current values and their corresponding disconnection times listed in VDE 0126-1-1 standard

Leakage current value (mA)	Disconnection time (s)
30	0.3
60	0.15
100	0.04

12 Proposed grid connected system

A grid-connected photovoltaic system uses PV panels in parallel or series to convert sunlight to DC power, and converters to convert AC current to DC current. There also exist DC/DC converters that are used to keep the PV system at maximum power operation. In this study, the input energy was generated using a PV panel. The PV panel is connected to the DC/DC boost converter. The boost converter uses the soft switching technique to boost the DC input voltage (100 V to 400 V). The system was further modified and was connected to a grid to become a grid-connected system. AC current was created by a new single-phase transformer-less inverter using the sinusoidal pulse width modulation technique and synchronized utility grid. The power fed from the PV device was controlled by controlling the frequency and duty cycle of switches S_1 and S_2 . Controlling frequency and duty cycles ensures power flow through the sources and between the source and the load.

Figure 6 shows the proposed two stage single phase transformer-less inverter, which consists of a resonant boost converter with an additional switch and a full bridge inverter with two additional switches SW_5 and SW_6 . In the boost converter both switches (S_1 and S_2) are IGBT transistors because of zero current switching. The switches SW_1 - SW_4 are high frequency MOSFET switches and the switches SW_5 and SW_6 are low frequency IGBT switches [94]. Furthermore, two extra capacitors connect switches SW_2 and SW_4 to eliminate the leakage current. In the second stage, the two phase leg including SW_1 - SW_4 switches operating at the switching frequency, and two additional switches SW_5 and SW_6 operating at the grid frequency were added. In the positive half cycle, SW_5 is always on and SW_1 and SW_4 commute at the switching frequency in order to produce V_{dc} and 0 states. Likewise, in

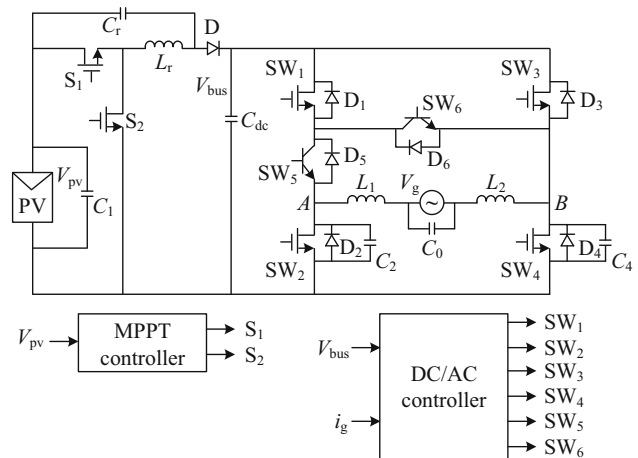

Fig. 6 Proposed two stage PV system

Table 4 Characteristics of proposed PV panel

Parameters	Values
Maximum power (P_{max})	500 W
Voltage at maximum power (V_{max})	105 V
Current at maximum Power (I_{max})	5 A
Short circuit current (I_{sc})	5.7 A
Open circuit voltage (V_{oc})	115 V

the negative half cycle, SW_6 is always on and SW_3 and SW_2 commutate at the switching frequency to create $-V_{dc}$ and 0 states. The proposed inverter was simulated in PSIM software. The candidate panel is assumed to generate a maximum power of 500 W. Details of the proposed panel used in the proposed Simulink model are shown in Table 4.

The operational characteristics of the proposed inverter was also analyzed. Design details of the proposed inverter are explained below. Power, input voltage, and DC output voltage of the system were arbitrarily chosen to be 500 W, 100 V and 400 V, respectively. Voltage gain (A) was approximately 4. A 40 μF capacitor was selected for input DC filtering. The resonant frequency was set to 50 KHz. For the selected resonance inductor and capacitor we had $L_f = 100 \mu H$ and $C_f = 100 nF$. The total design parameters of the simulated system are shown in Table 5. Real effects, such as dead time delays and non-ideality of components were also considered in simulation, so that real and simulated performance were as close as possible.

Figure 7 shows the block diagram of a MPPT controller. First, the power of the converter is calculated using current and voltage values. Second, maximum power is calculated using current and MPP voltage values and P&O method. Afterward, the calculated power value is compared with the

Table 5 Simulation parameters

Parameters	Values
Input voltage	100 V
DC voltage (V_{dc})	400 V
Rated power	500 W
Resonant inductor (L_f)	100 μH
Resonant capacitor (C_f)	100 nF
DC capacitor (C_{dc})	400 μF
Input capacitor (C_i)	50 μF
Switching frequency (DC/DC)	47 kHz
MOSFET switch frequency (DC/AC)	20 kHz
IGBT switch frequency (DC/AC)	50 Hz
Filter inductor ($L_{1,2}$)	10 mH
Filter capacitor (C_o)	0.2 μF
Extra capacitors	0.5 nF

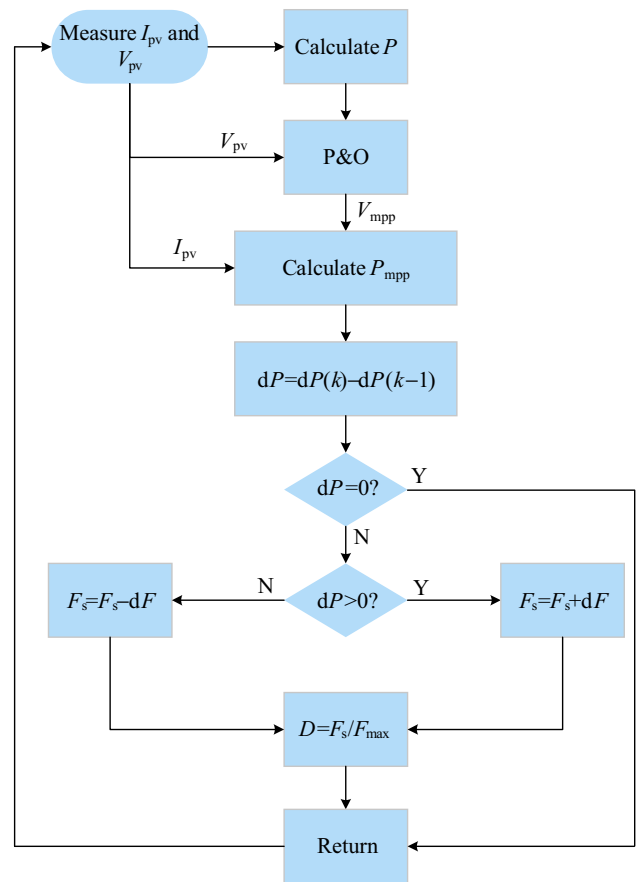

Fig. 7 Flowchart of MPPT controller of proposed DC/DC converter (first stage)

previous power value. The calculated value is used to decide about the direction of further changes in frequency and duty cycle. If change in power is positive, the change in frequency (dF) will be also be positive. Otherwise, the change in frequency (dF) will be negative. Finally, the calculated frequency is divided by the maximum switching frequency (47 kHz) to determine the value of duty cycle.

The proposed controller is designed as a double loop control system, in which the outer loop is used to regulate the DC bus voltage, while the inner loop regulates the AC line current. The inner loop has a high bandwidth, in order to provide fast dynamic responses. G_v and G_i are PI controllers. The magnitude of the output current (I_g) is given by the outer loop (G_v). This value is then multiplied by sine table in phase ($\sin\phi$) with the grid voltage. In the final step, error followed by PI controller and proper SPWM is generated.

Figure 8 shows voltage and current waveforms of the boost converter's switches. Switches S1 and S2 are turned on and off under zero current switching (ZCS). The current passing through the switches is sinusoidal, reducing switching loss.

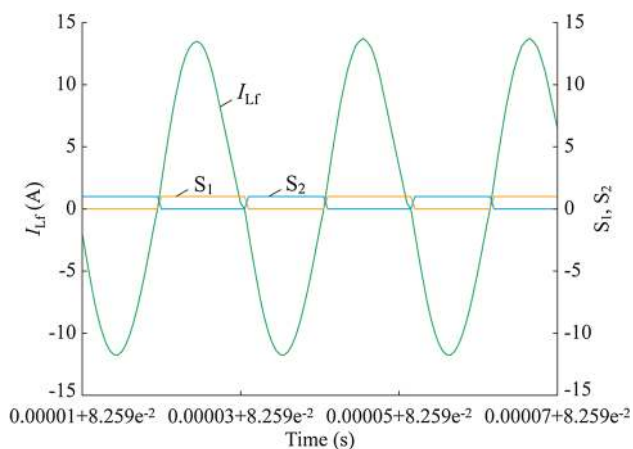

Fig. 8 Current waveform of inductor

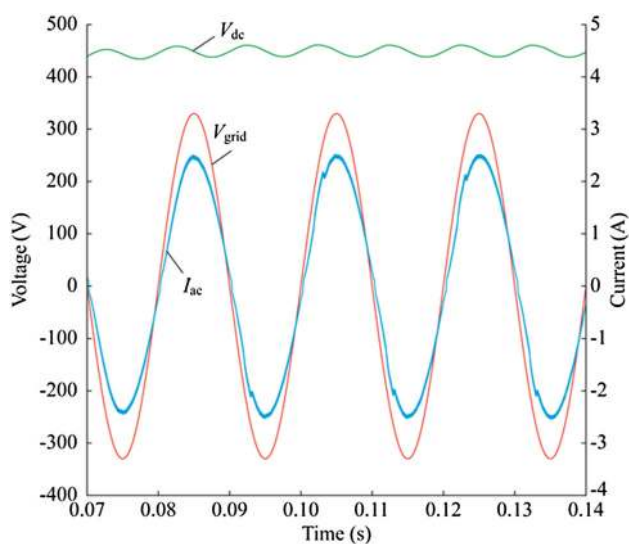

Fig. 9 DC bus voltage and AC currents/voltages waveform

Figure 9 shows the simulated current and voltage waveforms. The results show that (when working at full power) the proposed inverter and its controller can inject the input power into the grid with lower harmonic distortion (THD = 3.58%) and unity power factor. Figure 10 shows the simulated results of common mode voltage (V_{CM}), V_{AN} , V_{BN} . As it can be seen, when voltages V_{AN} and V_{BN} do not fluctuate, V_{CM} and V_P remain constant, and thus the leakage current (I_{cm}) is reduced considerably.

Figure 11 shows the simulation results under varying irradiance from 100% to 50%. The results show that the performance of the proposed system is satisfactory when working under changing irradiance. When irradiance is 1000 W/m^2 , the AC current is approximately 2.1 A, and when the radiation drops to 500 W/m^2 , the AC current approaches 1 A without any overshoot. As can be seen, maximum voltage is tracked by an MPPT controller. The

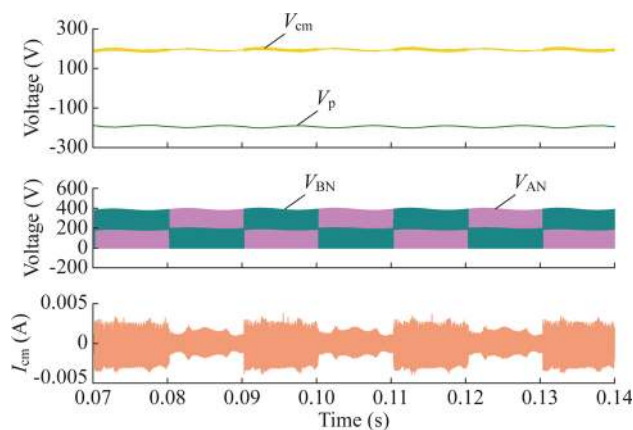

Fig. 10 DM characteristics of proposed inverter with constant input

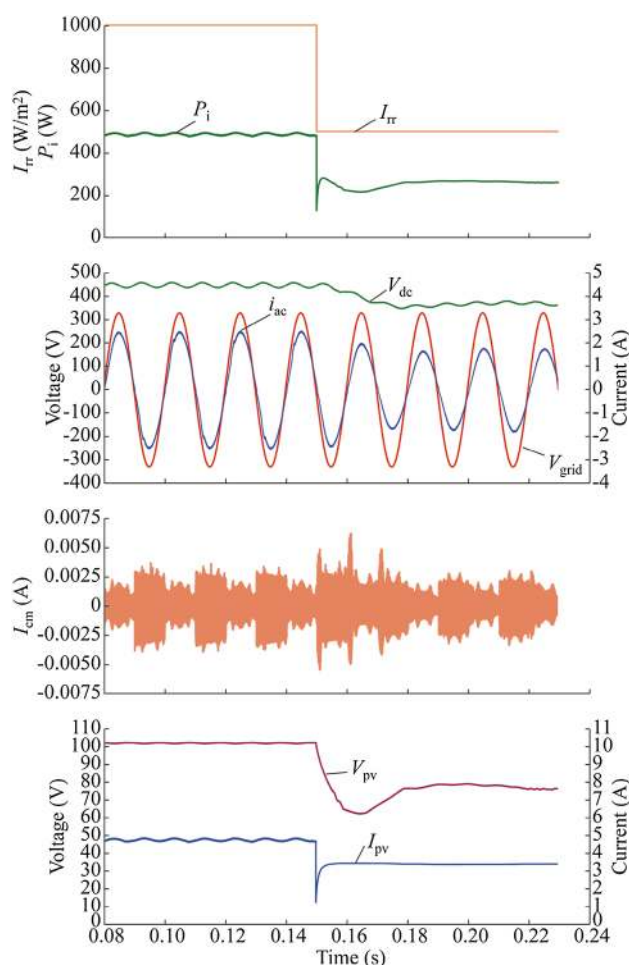

Fig. 11 Performance of proposed PV system by changing irradiance

proposed controller in the second stage maintains a proper DC voltage to ensure that the voltage is within a suitable range. In addition, RMS value of the leakage current (I_{cm}) is below 15 mA that satisfies the standards given by VDE-0126-1-1. Figure 11 also shows the waveforms of the

grid current, which are highly sinusoidal and synchronized with the grid voltage.

13 Conclusion

This paper was a review of the literature to help gain an understanding of the process of designing grid connected PV systems. It discussed DC/DC boost converters that boost the voltage of the current received from PV panels. It became clear that soft switching converters perform satisfactorily at high frequencies in reducing switching losses, decreasing the inductor and capacitor size, and increasing efficiency. Voltage-source inverters, such as full-bridge inverters and half bridge inverters, and their strengths and weaknesses were also discussed. Transformer-less inverters are used to improve the efficiency, lower the costs, and decrease the size. They were introduced to minimize the leakage current and enhance efficiency. A system was also proposed in this study that aimed to reduce the leakage current. It was able to provide a high quality output current and decrease the THD.

Open Access This article is distributed under the terms of the Creative Commons Attribution 4.0 International License (<http://creativecommons.org/licenses/by/4.0/>), which permits unrestricted use, distribution, and reproduction in any medium, provided you give appropriate credit to the original author(s) and the source, provide a link to the Creative Commons license, and indicate if changes were made.

References

- [1] Demirbas A (2009) Global renewable energy projections. *Energy Sources Part B Econ Plan Policy* 4(2):212–224
- [2] Fulekar MH (2010) *Environmental biotechnology*. CRC Press, Boca Raton
- [3] Kamalasadani S, Al-Olimat KS (2013) Modeling and control of a micro-grid set up using photovoltaic arrays. In: *Proceedings of 45th southeastern symposium on system theory*, Waco, USA, 11 March 2013, 8 pp
- [4] Kroposki B, DeBlasio R (2000) Technologies for the new millennium: photovoltaics as a distributed resource. In: *Proceedings of 2000 power engineering society summer meeting*, Seattle, USA, 16–20 July 2000, 4 pp
- [5] Sanjeevikumar P, Rajambal K (2008) Extra-high-voltage DC–DC boost converters topology with simple control strategy. *Model Simul Eng* 2008:1–8
- [6] Schaefer JC (1990) Review of photovoltaic power plant performance and economics. *IEEE Trans Energy Convers* 5(2):232–238
- [7] Kjaer SB, Pedersen JK, Blaabjerg B (2005) A review of single-phase grid-connected inverters for photovoltaic modules. *IEEE Trans Ind Appl* 41(5):1292–1306
- [8] Wolfs P (2008) A review of the single phase photovoltaic module integrated converter topologies with three different DC link configurations. *IEEE Trans Power Electron* 23(3):1320–1333
- [9] Ma L, Tang F, Zhou F et al (2008) Leakage current analysis of a single-phase transformer-less PV inverter connected to the grid. In: *Proceedings of 2008 IEEE international conference on sustainable energy technologies*, Singapore, 24–27 Nov 2008, 4 pp
- [10] Xiao H, Xie S (2010) Leakage current analytical model and application in single-phase transformerless photovoltaic grid-connected inverter. *IEEE Trans Electromagn Compat* 52(4):902–913
- [11] Lee JP, Min BD, Kim TJ et al (2009) Design and control of novel topology for photovoltaic DC/DC converter with high efficiency under wide load ranges. *J Power Electron* 9(2):300–307
- [12] Min BD, Lee J, Kim JH et al (2007) A novel grid-connected PV PCS with new high efficiency converter. In: *Proceedings of 2007 7th international conference on power electronics*, Daegu, South Korea, 22–26 Oct 2007, 4 pp
- [13] Reisi AR, Moradi MH, Jamsab S (2013) Classification and comparison of maximum power point tracking techniques for photovoltaic system: a review. *Renew Sustain Energy Rev* 19:433–443
- [14] El-Barbari S, Hofmann W (2000) Digital control of a three phase 4 wire PWM inverter for PV applications. In: *Proceedings of the IEEE industrial electronics society conference (IECON '00)*, 9 pp
- [15] Coelho RF, Schimtz L, Martins DC (2011) Grid-connected PV-wind-fuel cell hybrid system employing a supercapacitor bank as storage device to supply a critical DC load. In: *Proceedings of IEEE 33rd international telecommunications energy conference (INTELEC)*, Amsterdam, Netherlands, 9–13 Oct 2011, 10 pp
- [16] Molina MG, Mercado PE (2008) A new control strategy of variable speed wind turbine generator for three-phase grid-connected applications. In: *2008 IEEE/PES transmission and distribution conference and exposition: Latin America*, Bogota, Colombia, 13–15 Aug 2008, 8 pp
- [17] Patel MR (2005) *Wind and solar power systems: design, analysis, and operation*, 2nd edn. CRC Press, Boca Raton
- [18] Hersch P, Zweibel K (1982) Basic photovoltaic principles and methods. *Antimicrob Agents Chemother* 58(12):7250–7257
- [19] Geoffrey PCS, Walker R (2004) Cascaded DC–DC converter connection of photovoltaic modules. *IEEE Trans Power Electron* 19(4):1130–1139
- [20] Perez PJ, Almonacid G, Aguilera J et al (2008) RMS current of a photovoltaic generator in grid-connected PV systems: definition and application. *Int J Photoenergy* 4:464–477
- [21] Amrani AE, Mahrane A, Moussa FY et al (2007) Solar module fabrication. *Int J Photoenergy* 2007(4):136–151
- [22] Bose BK, Szczesny PM, Steigerwald RL (1985) Microcomputer control of a residential photovoltaic power conditioning system. *IEEE Trans Ind Appl* 21(5):1182–1191
- [23] Marnoto T, Sopian K, Ramli WAN et al (2007) Mathematical model for determining the performance characteristics of multicrystalline photovoltaic modules. In: *Proceedings of the 9th WSEAS international conference on mathematical and computational methods in science and engineering*, Trinidad and Tobago, 5–7 November 2007, 5 pp
- [24] Ahmad GE, Hussein HMS, El-Ghetany HH (2003) Theoretical analysis and experimental verification of PV modules. *Renew Energy* 28(8):1159–1168
- [25] Grandi G, Rossi C, Ostojic D et al (2009) A new multilevel conversion structure for grid-connected PV applications. *IEEE Trans Ind Electron* 56(11):4416–4426
- [26] Shimizu T, Hirakata M, Kamezawa T et al (2001) Generation control circuit for photovoltaic modules. *IEEE Trans Power Electron* 16(3):293–300

- [27] Li J, Wang H (2009) A novel stand-alone PV generation system based on variable step size INC MPPT and SVPWM control. In: Proceedings of 2009 IEEE 6th international power electronics and motion control conference, Wuhan, China, 17–20 May 2009, 5 pp
- [28] Liu X, Wang P, Loh PC (2010) Optimal coordination control for stand-alone PV system with nonlinear load. In: Proceedings of 2010 9th international power and energy conference, Singapore, 27–29 Oct 2010, 5 pp
- [29] Grandi G, Rossi C, Ostojic D et al (2009) A new multilevel conversion structure for grid-connected PV applications. *IEEE Trans Ind Electron* 56(11):4416–4426
- [30] Haeberlin H (2001) Evolution of inverters for grid connected PV-systems from 1989 to 2000. In: Proceedings of 17th European photovoltaic solar energy conference, Munich, Germany, 22–26 October 2001, 5 pp
- [31] Mohan N, Undeland TM (2007) Power electronics: converters, applications, and design. Wiley, New York
- [32] Elshaer M, Mohamed A, Mohammed O (2010) Smart optimal control of DC-DC boost converter in PV systems. In: Proceedings of IEEE/PES transmission and distribution conference and exposition: Latin America, Sao Paulo, Brazil, 8–10 Nov 2010, 7 pp
- [33] Rahman SA, Varma RK (2011) PSCAD/EMTDC model of a 3-phase grid connected photovoltaic solar system. In: Proceedings of North American power symposium, Boston, USA, 4–6 Aug 2011, 7 pp
- [34] Amjad M, Facta M, Mekhilef S (2013) Analysis and implementation of transformerless LCL resonant power supply for ozone generation. *IEEE Trans Power Electron* 28(2):650–660
- [35] Blaabjerg F, Teodorescu R, Liserre M (2006) Overview of control and grid synchronization for distributed power generation systems. *IEEE Trans Ind Electron* 53(5):1398–1409
- [36] Islam M, Mekhilef S (2014) High efficiency transformerless MOSFET inverter for grid-tied photovoltaic system. In: Proceedings of IEEE applied power electronics conference and exposition (APEC), Fort Worth, USA, 16–20 March 2014, 5 pp
- [37] Salas V, Ollás E (2009) Overview of the state of technique for PV inverters used in low voltage grid-connected PV systems: inverters below 10 kW. *Renew Sustain Energy Rev* 13(6):1541–1550
- [38] Rollier S, Richard B, Keller M (2005) Earth leakage control in solar inverters. *Power System Design Europe*
- [39] Mekhilef S, Omar AM, Muhammad KS (2006) An improved topology of digitally-controlled single-phase single-stage high DC voltage converter. In: Proceedings of IEEE power electronics specialists conference, Jeju, South Korea, 18–22 June 2006, 5 pp
- [40] Ishikawa T (2002) Grid-connected photovoltaic power systems: survey of inverter and related protection equipments. Report IEA PVPS T5-05
- [41] Gertmar L, Karlsson P, Samuelsson O (2005) On DC injection to AC grids from distributed generation. In: Proceedings of European conference on power electronics and applications, Dresden, Germany, 11–14 Sept 2005, 10 pp
- [42] Meinhardt M (2005) Improvement of photovoltaic inverter efficiency—targets, methods, limits. SMA Technologie AG
- [43] Haeberlin H, Borgna L, Kaempfer M (2006) New tests at grid-connected PV inverters: overview over test results and measured values of total efficiency η_{tot} . In: Proceedings of 21st European photovoltaic solar energy conference, Dresden, Germany, Sept 2006, 4 pp
- [44] Gu B, Dominic J, Lai JS et al (2013) High reliability and efficiency single-phase transformerless inverter for grid-connected photovoltaic systems. *IEEE Trans Power Electron* 28(5):2235–2245
- [45] Henze N, Degner T (2002) Radio interference of photovoltaic power systems. In: Proceedings of 16th international Wroclaw symposium and exhibition on EMC, Wroclaw, Poland, 25–28 June 2002, 6 pp
- [46] López Ó, Teodorescu R, Doval-Gandoy J (2016) Multilevel transformerless topologies for single-phase grid-connected converters. In: Proceeding of IECON, Paris, France, 6–10 Nov 2006, 5 pp
- [47] Kerekes T, Sera D, Mathe L (2012) Leakage current measurement in transformerless PV inverters. In: Proceedings of the international conference on optimisation of electrical and electronic equipment, Brasov, Romania, 24–26 May 2012, 6 pp
- [48] Nayar D (1997) A comparison of tri-level and bi-level current controlled grid-connected single-phase full-bridge inverters. In: Proceedings of the IEEE international symposium on industrial electronics, Guimaraes, Portugal, 7–11 July 1997, 6 pp
- [49] Araújo SV, Zacharias P, Mallwitz R (2010) Highly efficient single-phase transformerless inverters for grid-connected photovoltaic systems. *IEEE Trans Ind Electron* 57(9):3118–3128
- [50] Burger B, Kranzer D (2009) Extreme high efficiency PV-power converters. In: Proceedings of 13th European conference on power electronics and applications, Barcelona, Spain, 8–10 Sept 2009, 13 pp
- [51] López Ó, Freijedo FD, Yepes AG et al (2010) Eliminating ground current in a transformerless photovoltaic application. *IEEE Trans Energy Convers* 25(1):140–147
- [52] Zhang K, Zhou Y, Zhang Y et al (2007) Reduction of common mode EMI in a full-bridge converter through automatic tuning of gating signals. In: Proceedings of IEEE 5th international power electronics and motion control conference, Shanghai, China, 14–16 Aug 2006, 5 pp
- [53] Hinz H, Mutschler P (1996) Single phase voltage source inverters without transformer in photovoltaic applications. In: Proceedings of 7th International Power Electronics and Motion Control (PEMC)
- [54] Jiang QJ, Brown Q (2001) Comparison of electromagnetic compatibility of different PV inverter. In: Proceedings of 4th IEEE international conference on power electronics and drive systems, Denpasar, Indonesia, 25–25 Oct 2001, 5 pp
- [55] Shen CL, Peng ST (2007) A half-bridge PV system with bi-direction power flow controlling and power quality improvement. In: Proceedings of 7th international conference on power electronics and drive systems, Bangkok, Thailand, 27–30 Nov 2007, 7 pp
- [56] Gonzalez R, Gubia E, Lopez J et al (2008) Transformerless single-phase multilevel-based photovoltaic inverter. *IEEE Trans Ind Electron* 55(7):2694–2702
- [57] Victor M, Greizer F, Bremicker S et al (2004) Method of converting a DC voltage of a dc source, in particular of a photovoltaic DC source, in an AC voltage. European Patent, EP1626494, DE10204030912
- [58] Vazquez G, Kerekes T, Rolan A et al (2009) Losses and CMV evaluation in transformerless grid-connected PV topologies. In: Proceedings of IEEE international symposium on industrial electronics, Seoul, South Korea, 5–8 July 2009, 5 pp
- [59] Schimpf F, Norum LE (2008) Grid connected converters for photovoltaic, state of the art, ideas for improvement of transformerless inverters. Dissertation Helsinki University of Technology
- [60] Gonzalez R, Lopez J, Sanchis P et al (2007) Transformerless inverter for single-phase photovoltaic systems. *IEEE Trans Power Electron* 22(2):693–697
- [61] Debnath D, Chatterjee K (2016) Neutral point clamped transformerless grid connected inverter having voltage buck–boost capability for solar photovoltaic systems. *IET Power Electron* 9(2):385–392



- [62] Calais M, Agelidis VG, Meinhardt M (1999) Multilevel converters for single-phase grid connected photovoltaic systems: an overview. *Sol Energy* 66(5):325–335
- [63] Zhao ZL, Zheng Y, Zhan CJ et al (1999) Analysis on voltage unbalance between the inner and outer devices in three level IGBT converters. In: Proceedings of IEEE international conference on power electronics and drive systems, Hong Kong, China, 27–29 July 1999, 7 pp
- [64] Brückner T, Bernet S, Güldner H (2005) The active NPC converter and its loss-balancing control. *IEEE Trans Ind Electron* 52(3):855–868
- [65] Buso S, Malesani L, Mattavelli P (1998) Comparison of current control techniques for active filter applications. *IEEE Trans Ind Electron* 45(5):722–729
- [66] Kazmierkowski MP, Malesani L (1998) Current control techniques for three-phase voltage-source PWM converters: a survey. *IEEE Trans Ind Electron* 45(5):691–703
- [67] Fukuda S, Yoda T (2001) A novel current-tracking method for active filters based on a sinusoidal internal model. *IEEE Trans Ind Appl* 37(3):888–895
- [68] Ciobotaru M, Teodorescu R, Blaabjerg F (2006) Control of single-stage single-phase PV inverter. *Eur Power Electron Drives J* 16(3):20–26
- [69] Salam Z, Ahmed J, Merugu BS (2013) The application of soft computing methods for MPPT of PV system: a technological and status review. *Appl Energy* 107:135–148
- [70] Kwon M, Park J, Choi S (2013) High gain soft-switching bidirectional DC-DC converters for eco-friendly vehicles. In: Proceedings of IEEE applied power electronics conference and exposition, Long Beach, USA, 17–21 March 2013, 6 pp
- [71] Prakash SL, Arutchelvi M, Sharon SS (2015) Simulation and performance analysis of MPPT for single stage PV grid connected system. In: Proceedings of 9th international conference on intelligent systems and control, Coimbatore, India, 9–10 Jan 2015, 6 pp
- [72] Ishaque K, Salam Z (2013) A review of maximum power point tracking techniques of PV system for uniform insolation and partial shading condition. *Renew Sustain Energy Rev* 19:475–488
- [73] Ahmed J, Salam Z (2015) An improved perturb and observe (P&O) maximum power point tracking (MPPT) algorithm for higher efficiency. *Appl Energy* 150:97–108
- [74] Kim TY, Ahn HG, Park SK et al (2001) A novel maximum power point tracking control for photovoltaic power system under rapidly changing solar radiation. In: Proceedings of IEEE international symposium on industrial electronics, Pusan, South Korea, 12–16 June 2001, 4 pp
- [75] Bendib B, Krim F, Belmili H et al (2014) Advanced fuzzy MPPT controller for a stand-alone PV system. *Energy Procedia* 50:383–392
- [76] Messalti S, Harrag A, Loukriz A (2017) A new variable step size neural networks MPPT controller: Review, simulation and hardware implementation. *Renew Sustain Energy Rev* 68:221–233
- [77] Shaiek Y, Smida MB, Sakly A et al (2013) Comparison between conventional methods and GA approach for maximum power point tracking of shaded solar pv generators. *Solar Energy* 90:107–122
- [78] Kobayashi K, Matsuo H, Sekine Y (2004) A novel optimum operating point tracker of the solar cell power supply system. In: Proceedings of power electronics specialists conference, Aachen, Germany, 20–25 June 2004, 4 pp
- [79] Noguchi T, Togashi S, Nakamoto R (2000) Short-current pulse based adaptive maximum-power-point tracking for photovoltaic power generation system. In: Proceedings of IEEE international symposium on industrial electronics, Cholula, Mexico, 4–8 Dec 2000, 6 pp
- [80] Kitano T, Matsui M, Xu DH (2001) Power sensor-less mppt control scheme utilizing power balance at dc link-system design to ensure stability and response. In: Proceedings of 27th annual conference of the IEEE industrial electronics society, Denver, USA, 29 Nov–2 Dec 2001, 6 pp
- [81] Leyva R, Alonso C, Queindec I et al (2006) MPPT of photovoltaic systems using extremum seeking control. *IEEE Trans Aerosp Electron Syst* 42(1):249–258
- [82] Coelho RF, Concer FM, Martins DC (2010) A MPPT approach based on temperature measurements applied in PV systems. In: Proceedings of 9th IEEE/IAS international conference on industry applications, Sao Paulo, Brazil, 8–10 Nov 2010, 6 pp
- [83] Li Y, Peng Y, Liu F et al (2017) A controllably inductive filtering method with transformer-integrated linear reactor for power quality improvement of shipboard power system. *IEEE Trans Power Deliv* 32(4):1817–1827
- [84] Li Y, Liu Q, Hu S et al (2017) A virtual impedance comprehensive control strategy for the controllably inductive power filtering system. *IEEE Trans Power Electron* 32(2):920–926
- [85] Platakis A, Bleizgys V, Lucinskis A et al (2012) Investigation of photovoltaic inverter power quality. *Prz Elektrotechniczny* 88(7):180–182
- [86] Hassaine L, Olías E, Quintero J et al (2014) Power control for grid connected applications based on the phase shifting of the inverter output voltage with respect to the grid voltage. *Int J Electr Power Energy Syst* 57:250–260
- [87] Bollen MH (2000) Understanding power quality problems. IEEE Press, New York
- [88] Zhong QC (2013) Harmonic droop controller to reduce the voltage harmonic of inverter. *IEEE Trans Ind Electron* 60(3):936–945
- [89] Zia FB, Salim KM, Yousuf NB et al (2012) Design and implementation of a single phase grid tie photo voltaic inverter. In: Proceedings of 2nd international conference on the developments in renewable energy technology, Dhaka, Bangladesh, 5–7 Jan 2012, 4 pp
- [90] Maswood A, Rahman M (1996) Performance parameters of a pulse-width modulation voltage source inverter with proportional-integral controller under non-ideal conditions. *Electr Power Syst* 38:19–24
- [91] Souza KCAD, Castro MRD, Antunes F (2002) A DC/AC converter for single-phase grid-connected photovoltaic systems. In: Proceedings of IECON, Sevilla, Spain, 5–8 Nov 2002, 5 pp
- [92] Thacker T, Wang R, Dong D et al (2009) Phase-locked loops using state variable feedback for single-phase converter systems. In: Proceedings of IEEE applied power electronics conference and exposition, Washington, USA, 15–19 Feb 2009, 6 pp
- [93] Salas V, Olías E, Alonso M et al (2008) Overview of the legislation of DC injection in the network for low voltage small grid-connected PV systems in Spain and other countries. *Renew Sustain Energy Rev* 12(2):575–583
- [94] Chen B, Lai JS (2015) A family of single-phase transformerless inverters with asymmetric phase-legs. In: Proceedings of IEEE applied power electronics conference and exposition, Charlotte, USA, 15–19 March 2015, 5 pp
- [95] Siwakoti YP, Blaabjerg F (2016) A novel flying capacitor transformerless inverter for single-phase grid connected solar photovoltaic system. In: Proceedings of 7th international symposium on power electronics for distributed generation systems, Vancouver, Canada, 27–30 June 2016, 6 pp
- [96] Victor M, Greizer F, Bremicker S et al (2008) Method of converting a direct current voltage from a source of direct

current voltage, more specifically from a photovoltaic source of direct current voltage, into a alternating current voltage. U.S. Patent, No. 7, 411, 802

- [97] Rooij D, Andrew M, Glaser JS et al (2011) High efficiency photovoltaic inverter. U.S. Patent, No. 8,023,297
- [98] Kerekes T, Teodorescu R, Rodríguez P et al (2011) A new high-efficiency single-phase transformerless PV inverter topology. *IEEE Trans Ind Electron* 58(1):184–191
- [99] Heribert K, Christoph S, Jurgen S (2003) Inverter for transforming a DC voltage into an AC current or an AC voltage. Patent EP1369985A2
- [100] Yu W, Lai JS, Qian H et al (2011) High-efficiency MOSFET inverter with H6-type configuration for photovoltaic

nonisolated AC-module applications. *IEEE Trans Power Electron* 26(4):1253–1260

Mohsen SHAYESTEGAN received the B.S. degree from IAU, Iran, in 2006 and the M.S. degree from UPM, Malaysia in control and automation, in 2013. He is currently working toward the Ph.D. degree in power electronic engineering from the national university of Malaysia. His research interests include PV systems, control and automation, power electronics applications.

