

Overview of the MEDLI Project

Michael J. Gazarik¹, Alan Little², F.Neil Cheatwood³, Michael J.Wright⁴, Jeff A. Herath⁵, Edward R. Martinez⁶, Michelle Munk⁷, Frank J. Novak⁸, Henry S. Wright⁹

⁽¹⁾NASA Langley Research Center, M/S 468, Hampton VA 23681, USA Michael.J.Gazarik@Nasa.Gov

⁽²⁾NASA Langley Research Center, M/S 434, Hampton VA 23681, USA A.Little@Nasa.Gov

⁽³⁾NASA Langley Research Center, M/S 489, Hampton VA 23681, USA F.M.Cheatwood@Nasa.Gov

⁽⁴⁾NASA Ames Research Center, M/S 230-2, Moffett Field CA 94035, USA Michael.J.Wright@Nasa.Gov

⁽⁵⁾NASA Langley Research Center, M/S 489, Hampton VA 23681, USA Jeffrey.A.Herath@Nasa.Gov

⁽⁶⁾NASA Ames Research Center, M/S 230-3, Moffett Field CA 94035, USA Edward.R.Martinez@Nasa.Gov

⁽⁷⁾NASA Langley Research Center, M/S 489, Hampton VA 23681, USA Michelle.M.Munk@nasa.gov

⁽⁸⁾NASA Langley Research Center, M/S 468, Hampton VA 23681, USA Frank.J.Novak@Nasa.Gov

⁽⁹⁾NASA Langley Research Center, M/S 489, Hampton VA 23681, USA Henry.S.Wright@Nasa.Gov

ABSTRACT

The Mars Science Laboratory Entry, Descent, and Landing Instrumentation (MEDLI) Project's objectives are to measure aerothermal environments, sub-surface heatshield material response, vehicle orientation, and atmospheric density for the atmospheric entry and descent phases of the Mars Science Laboratory (MSL) entry vehicle. The flight science objectives of MEDLI directly address the largest uncertainties in the ability to design and validate a robust Mars entry system, including aerothermal, aerodynamic and atmosphere models, and thermal protection system (TPS) design. The instrumentation suite will be installed in the heatshield of the MSL entry vehicle. The acquired data will support future Mars entry and aerocapture missions by providing measured atmospheric data to validate Mars atmosphere models and clarify the design margins for future Mars missions. MEDLI thermocouple and recession sensor data will significantly improve the understanding of aeroheating and TPS performance uncertainties for future missions. MEDLI pressure data will permit more accurate trajectory reconstruction, as well as separation of aerodynamic and atmospheric uncertainties in the hypersonic and supersonic regimes. This paper provides an overview of the project including the instrumentation design, system architecture, and expected measurement response.

1 INTRODUCTION

MSL is taxing the limits of current modeling capabilities for Mars entry missions. Aeroheating uncertainties are greater than 50% on the heatshield, due primarily to early transition to turbulence, surface chemistry, and ablation induced roughness. A primary

source of this uncertainty is a lack of relevant flight data to validate and improve computational models. Flight data are required for engineering validation of atmospheric models especially in terms of Martian atmospheric winds and density, aerothermodynamics models, entry system aerodynamics models, and TPS response models. The data obtained will allow validation of Earth-based physical models and subscale testing procedures for the Martian carbon-dioxide atmosphere. In addition, Entry, Descent, and Landing (EDL) flight data will allow separation of the atmospheric and aerodynamic performance issues that is not possible with inertial data alone. Uncertainties in these models are significant, and limit the ability to design and validate a more robust EDL architecture for future planetary missions.

The database of EDL flight data is sparse, with the bulk of data acquired in the 1960s, primarily in support of the Apollo program. Furthermore, for the most part, these data sets have not been critically evaluated or used for code-validation purposes in more than 30 years.¹ Recent attempts to propose dedicated flight experiments have failed to reach fruition, largely because of budget constraints and competing mission objectives. While many early planetary missions contained at least a minimal set of engineering instruments (including Pioneer, Venus, Viking, and Galileo), attempts to instrument recent science mission vehicles have been largely unsuccessful. This policy change was mainly because of conflicting mission assurance concerns and the high priority on utilization of limited financial resources for science payloads.

While a brief highlight of MEDLI-relevant EDL flight experience is given here, a more comprehensive summary of aeroheating flight data is provided in [1]

and an overview of the flush air data system flown on the Shuttle is given in [2].

In 1976, the two Viking entry vehicles were instrumented with pressure and temperature sensors and provided the first aerodynamic flight data on Mars. Both probes were 70-degree sphere-cones with an ablative forebody heat shield made of a lightweight silicone-based ablator, called SLA-561V, injected into a phenolic fiberglass honeycomb structure. Atmospheric properties along the reconstructed flight trajectories are provided by Seiff and Kirk.³ Each probe included a base pressure sensor and two surface-mounted aft-body temperature sensors: one on the fiberglass inner cone and one on the aluminum skin of the outer cone.⁴ The base pressure sensor was mounted inside the vented aeroshell. Three of the four temperature sensors functioned as expected, but the sensor on the aluminum outer cone of the Viking I entry vehicle failed near the peak heating point. Edquist et. al examined the aft-body thermocouple data on Viking I and showed that modern computational tools generally under-predict the measured heating rates.⁵

The Shuttle Entry Air Data System (SEADS) was a flush mounted orifice air data system in the nose cap of the Shuttle Orbiter. It provided accurate data across the Orbiter speed range throughout the sensible atmospheric flight region. Fourteen pressure ports were located in the shape of a cruciform in the nose cap. Acquired data, when coupled with static pressure ports mounted on the fuselage, permitted computation of attack, angle of side slip, Mach number, and velocity.²

In 1997, the entry vehicle of Mars Pathfinder was instrumented with nine thermocouples (TC) embedded at various depths within the vehicle's TPS (also SLA-561V) and three platinum resistance thermometers (PRTs) used to provide a reference calibration point for the TC data.¹ Three of the nine thermocouples (including two of three on the backshell) returned no useful data, and apparently failed prior to or during launch.⁶ Of the other six thermocouples, the temperature data from those on the heatshield (TC2-TC6) is incorrect because the cold-junction temperature from PRT2 was pegged at the low temperature cutoff during entry. This calibration error was partially corrected with pre-launch calibration data, and the resulting reconstructed heat flux was consistent with approximately 85% of the predicted laminar fully catalytic level.⁶

The MEDLI dataset will provide the first non-Earth entry aeroheating data since the Pathfinder mission, and will provide more than an order of magnitude more data than all previous Mars entry missions combined. The

acquired data will help answer some of the fundamental questions relating to leeside turbulent heating levels, forebody transition, and TPS material response in a carbon dioxide atmosphere, and will permit a more accurate trajectory reconstruction, as well as enable separation of aerodynamic and atmospheric uncertainties in the hypersonic and supersonic regimes.

1.1 Overview of MSL

The MSL EDL system is a new architecture based on Viking heritage technologies and designed to meet the challenges of landing larger mass payloads on Mars.⁷ In accordance with level-1 requirements, the MSL EDL system is being designed to land an 850 kg rover to altitudes as high as 1 km above the Mars Orbiter Laser Altimeter (MOLA) defined areoid and within 10 km of the desired landing site. Accordingly, MSL will enter and land the greatest entry mass, fly the largest aeroshell, generate the highest hypersonic lift-to-drag ratio, and deploy the largest Disk-Gap-Band supersonic parachute of any previous mission to Mars. The primary departure from heritage design is the use of the sky crane terminal descent system, which will replace the Pathfinder heritage airbags and lower the rover to the Mars surface on a tether. Major EDL events include the hypersonic guided entry, supersonic parachute deploy and inflation, subsonic heatshield jettison, terminal descent sensor acquisition, powered descent initiation, sky crane terminal descent, rover touchdown detection, and descent stage flyaway. As shown in Fig. 1, MSL contains five major subsystems. The cruise stage provides protection and support to the entry vehicle and rover throughout the in-space cruise phase and is jettisoned prior to atmospheric entry. The backshell and heatshield form the entry vehicle which houses the rover and descent stage. While descending on the subsonic parachute, the heatshield is separated from the entry vehicle. The descent stage then separates from the backshell and performs the terminal descent, and lowers the rover to the Martian surface.

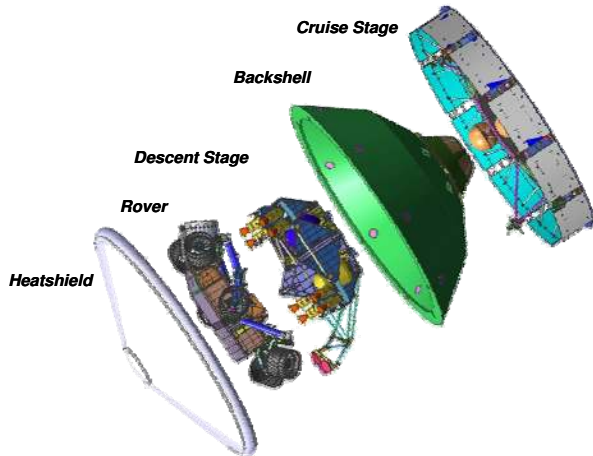

Figure 1. MSL Major Subsystems.

1.2 Overview of MEDLI instrumentation

The MEDLI instrumentation suite consists of seven pressure ports and seven integrated sensor plugs, as well as supporting electronics and wiring. The suite consists of three main subsystems:

- MEDLI Integrated Sensor Plug (MISP)

A circular plug formed from the heatshield TPS material containing four embedded thermocouples and a recession sensor.

- Mars Entry Atmospheric Data System (MEADS)

A series of through-holes, or ports, in the TPS that connect via tubing to pressure transducers mounted on the heatshield interior.

- Sensor Support Electronics (SSE)

Electronics that condition sensor signals, provide power to the sensors, and interface to the MSL data acquisition system.

All instrumentation is installed in the forebody heatshield of the MSL entry vehicle at locations determined by the science team to maximize the value of the aerothermal, aerodynamic, and TPS material response data. The stacked thermocouples will record temperature data at varying depths in the heatshield TPS. The recession sensors will measure an isotherm in the thermal protection system as it ablates during atmospheric entry. The pressure ports are arranged in a bilaterally symmetric pattern about the stagnation point to provide a flush atmospheric data system from which aerodynamic data can be computed.

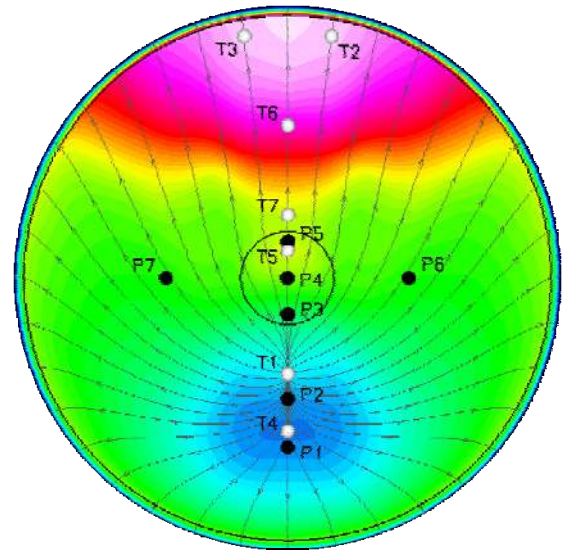

Figure 2. Locations of MISP plugs and MEADS ports on the MSL heatshield.

The locations of the pressure ports (P) and sensor plugs (T) are shown in Fig. 2. The heatshield is colored by the predicted peak heating rate during entry. No instrumentation was placed in the backshell due to schedule considerations; the backshell is on the critical path for the overall aeroshell delivery. The MEDLI subsystems are shown in the cross-sectional view of the MSL entry vehicle in Fig. 3.

1.3 Timeline and operational concept

The MEDLI instrumentation will be operational from approximately ten minutes before atmospheric entry to heatshield separation, totaling approximately fourteen minutes in duration. Acquired data will be recorded and stored on the MSL rover. After landing, the data will be transmitted back to Earth for analysis. MEDLI instrumentation will generate approximately 0.9 MBytes of raw data. With overhead and synchronization data, the total un-margined data volume is expected to be 1.13 MBytes.

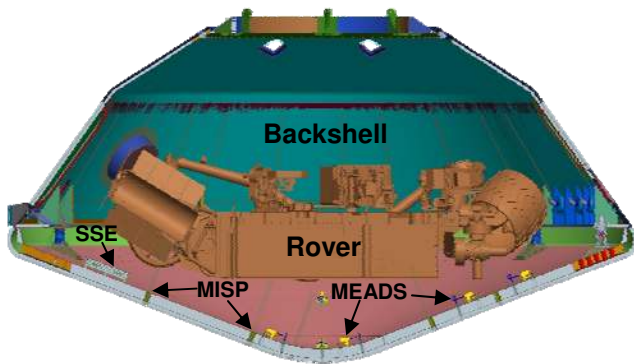

Figure 3. MEDLI Instrumentation in MSL entry vehicle.

2 MEASUREMENT OBJECTIVES

The MEDLI science package consists of two subsystems. MISP gathers data to support aerothermal and TPS response model validation, while the MEADS system gathers pressure data to support the validation of aerodynamic and atmospheric models.

2.1 Aerothermal/TPS Objectives

The design of a low mass and reliable TPS system for Martian atmospheric entry requires an accurate prediction of the encountered aerothermal environment and the subsequent TPS material response. The peak heat flux (along with surface pressure and shear stress) determines the thermal protection material selected for the heatshield, while the total integrated heat load determines the ultimate thickness of required material.

The primary uncertainty in the ability to accurately predict Mars entry heating levels for MSL class vehicles is the onset of turbulent heating. Although prior Mars missions were predicted to be dominated by laminar heating, the larger, lifting, higher ballistic coefficient MSL entry vehicle is predicted to transition to turbulence well before peak heating. Significant uncertainties exist in our ability to predict such a turbulent flow, particularly in a reacting carbon dioxide atmosphere. Baseline turbulent heating levels can be further augmented by roughness effects due to ablation of the TPS material. Recent wind tunnel tests in support of MSL have also shown an apparent localized heating augmentation (occasionally attributed to transition) in the stagnation region of the vehicle. A second significant source of aeroheating uncertainty is catalytic heating in a dissociated carbon dioxide atmosphere. Catalysis, in which the TPS surface facilitates the

recombination of incident species, can be a large contributor to the total heating rate. No fully validated model currently exists to accurately predict the catalytic behavior of Mars TPS materials under flight conditions, and thus conservative design assumptions are employed to model this effect. These aeroheating uncertainties, combined with other effects such as angle of attack and atmospheric dispersions, result in a 3σ uncertainty level of over 50% for this mission.⁸ A more detailed discussion of the aerothermal modeling needs for future Mars entry missions is given in [9].

In regards to TPS material response modeling, the primary uncertainty is the recession rate of the SLA-561V TPS material, particularly in a shear flow environment. SLA is a glassy ablator, and therefore the surface recession is governed by a complex combination of vaporization and possible glass melt flow driven by shear gradients. In contrast, the in-depth thermal performance of the TPS material is believed to be well understood (assuming that the surface recession is accurately predicted). The primary need for in-depth thermal data is therefore to validate the current TPS performance models in an in-situ flight environment.

2.2 Atmospheric/Aerodynamic Objectives

The MEADS subsystem will demonstrate the hypersonic through low supersonic performance of a blunt body Flush Atmospheric Data System (FADS) during a high-energy entry using in-situ pressure measurements, and will allow a more accurate assessment of the aerodynamic and aerothermodynamic performance of the entry system. The acquisition of a series of local, discrete surface pressure measurements on the MSL entry aeroshell during the atmospheric entry and decent phase, in conjunction with the MSL flight system inertial measurement unit (IMU) data, will allow a more accurate post-flight reconstruction of the complete entry aeroshell states and atmospheric environmental data (including low altitude wind information at supersonic conditions). In particular, the acquired pressure data will allow a more accurate estimation of the dynamic pressure (q_{bar}), angle-of-attack (α), and angle-of sideslip (β) by allowing separation of the aerodynamic and atmospheric density uncertainties. In addition, the measured pressure data coupled with the IMU data will allow the determination of the atmospheric density, which is known to vary considerably within the Martian atmosphere.

In January, 2004, the Mars Exploration Rover (MER) entry vehicles successfully landed on the Martian surface. However, the descent of the MER rover entry vehicles, exhibited larger dispersions in angle-of-attack than expected¹⁰. Expected angles-of-attack were on the

order of 1-2 degrees while post-flight reconstruction suggested 4-9 degrees were exhibited. While a cause for the dispersion was identified, a pressure data set such as that provided by MEADS would have greatly improved the post-flight trajectory reconstruction, and assisted in the identification of the root-cause of the observed flight dynamic anomalies.

2.3 Summary of Science Objectives

Based on the preceding discussion, a set of twelve science objectives was defined for MEDLI. These are summarized in Table 1 and

Table 2. In each table, the objectives are listed in the first column, and the set of instrumentation (ports or plugs) that are used to satisfy the objective are listed in the subsequent columns. The objectives shown with gray shading partially satisfy the original science goals. Maximizing satisfaction of these objectives determined both the total number and placement of instrumentation on the MSL heatshield; however, other mission constraints prevented the MEDLI suite from fully answering all proposed objectives. In particular, a further understanding of the importance of catalytic heating on the overall basic heating rate can only be inferred from the baseline MEDLI instrumentation suite.

Table 1. Aerothermal/TPS Science Objectives

Technical Objectives	Location						
	T1	T2	T3	T4	T5	T6	T7
Basic Aeroheating	X	X	X	X	X	X	X
Stagnation Point Heating	X			X			
Turbulent Leaside Heating		X	X		X	X	X
TPS Recession Rate		X	X		X	X	X
Windside Heating Augmentation	X			X			
TPS Total Recession		X	X		X	X	X
Subsurface Material Response.	X	X	X	X	X	X	X
Turbulent Transition		X	X			X	X

Table 2. Aerodynamic/Atmospheric Science Objectives

Technical Objectives	Location						
	P1	P2	P3	P4	P5	P6	P7
Basic Pressure Distribution	X	X	X	X	X	X	X
Angle of Attack	X	X	X	X	X		
Angle of Sideslip				X		X	X
Dynamic Pressure	X	X					
Mach Number	X	X					

3 SYSTEM ARCHITECTURE

MEDLI consists of seven pressure ports and seven integrated sensor plugs all installed in the forebody heatshield of the MSL vehicle. The sensors are wired to the SSE that provides electrical power, conditions, and digitizes the sensor signals. The digital data stream is sent to the MSL Descent Stage Power and Analog Module (DPAM) over an RS-422 bus. The DPAM then relays the data to one of the MSL Rover Compute Elements (RCE) over the MSL EDL-1553 bus for storage until the data set is sent to Earth after landing.

MEDLI utilizes three basic measurements in combination to achieve its science objectives: Temperature, Isotherm, and Pressure.

- Temperature measurements will be made using commercial type-K thermocouples installed at various depths within the TPS material.
- Isotherm measurements will be made using a series of Hollow aErothermal Ablation and Temperature (HEAT) sensors, developed at NASA Ames Research Center, that allow reconstruction of the TPS recession rate.
- Pressure measurements will be made using pressure transducers mounted on the inside of the MSL heatshield, and connected to the outside surface through tubing, and a through-hole port in the TPS material.

MEDLI utilizes one autonomous mode: upon initiation of power, the SSE will begin conditioning and digitizing the sensor signals. From cruise stage separation until heatshield separation, the DPAM will receive the MEDLI sensor data, and the RCE in the rover will request and store the acquired data. The DPAM will request the data from each address assigned to MEDLI at a 64 Hz rate. This data is held in a buffer

in the DPAM and transferred across the EDL-1553 bus. Only every fourth sample is stored thereby reducing the effective MEDLI sampling rate to 8 Hz for each address. This is a standard function of the DPAM and RCE, and requires only changes to the look-up table that selects the channels to be sampled and their sample rate.

3.1 MSL Accommodations

MSL provides the accommodations for the MEDLI instrumentation and avionics. MSL provides the mechanical, electrical and avionics interfaces as shown in Fig. 4. The MEDLI mass allocation is 12.5 kg on the heatshield for the SSE, MEADS, and MISP, and 2.5 kg on the backshell for power, avionics cabling, and the associated cable cutters. The power allocation for MEDLI is 30W during EDL while no power is provided during the launch and cruise phases. The avionics interface to the DPAM is an RS-422 bus. The memory allocation in the RCE is 1.5 Mbytes for storage of the acquired data. The cable harness from the SSE to the DPAM is routed through a cable cutter at the heatshield/backshell interface, and then through a second cable cutter at the interface to the DPAM in the descent stage.

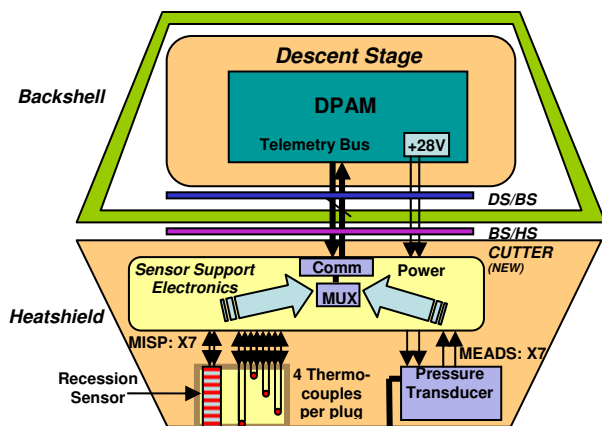

Figure 4. MSL Accommodations and Interfaces.

The components mounted on the inside of the heatshield, the MEADS transducers and the SSE, are fastened to standard inserts in the heatshield structure with thermal isolation standoffs. A custom designed through-hole with a stainless steel sleeve provides a clear and secure path from the port in the TPS through the heatshield honeycomb structure to the pressure transducer mounted in the heatshield interior. The sensor plugs will be integrated into the TPS by Lockheed Martin Space Systems Corporation (LMSSC)

using an established flight-qualified SLA repair procedure.

3.2 MISP

MISP is an instrumented plug that is installed in the TPS. Each plug is made from the heatshield TPS material and includes four embedded thermocouples at varying depths and one recession sensor. The sensor wiring is routed through penetrations in the TPS behind each plug and through the heatshield structure. Fig. 5 illustrates the MISP plug and the cavity in the TPS with heatshield structure in which it is installed using a standard LMSSC TPS repair technique.

Each MISP plug is 33 mm (1.3”) in diameter with a total depth of 20.3 mm (0.8”) and contains four Type K thermocouples. The thermocouples are installed in a U-shaped design at 2.54, 5.08, 10.16, 15.24 mm (0.1, 0.2, 0.4, and 0.6”) from the surface of the plug. The plug itself is installed flush to the overall outer surface of the TPS. The top two thermocouples in each plug are used primarily to reconstruct the aerothermal environment during entry and descent, while the two deeper thermocouples are used to validate the thermal response of the TPS material. At some locations the near surface thermocouples may fail during descent due to over temping. This is expected and occurs due to the desire to select a single set of TC depths that is globally optimized for all seven locations and a wide variety of possible entry trajectories.

The recession sensor, named Hollow aErothermal Ablation and Temperature (HEAT), is shown schematically in Fig. 6. The HEAT sensor measures the temporal progression of a 700 K isotherm through the TPS during entry and descent. This sensor operates on similar principles to the Analog Resistance Ablation Detector (ARAD) flown on the Galileo probe,¹¹ but the design has been significantly modified to allow for accommodation into a variety of TPS materials, and to produce improved signal quality and reduction of signal dropouts. A constant current excitation of 1 mA is provided by the SSE. The sensor element becomes electrically conductive as the surface of the TPS and the HEAT sensor is charred. As the char layer-virgin material interface advances, the HEAT length and voltage output decreases. The measurement range is 0 to 13 mm (0 to 0.52”) from the TPS outer mold line with a measurement accuracy of ± 0.5 mm. The HEAT sensor is sampled at 8 Hz by the SSE. More information on the development and operation of the HEAT sensor can be found in [12].

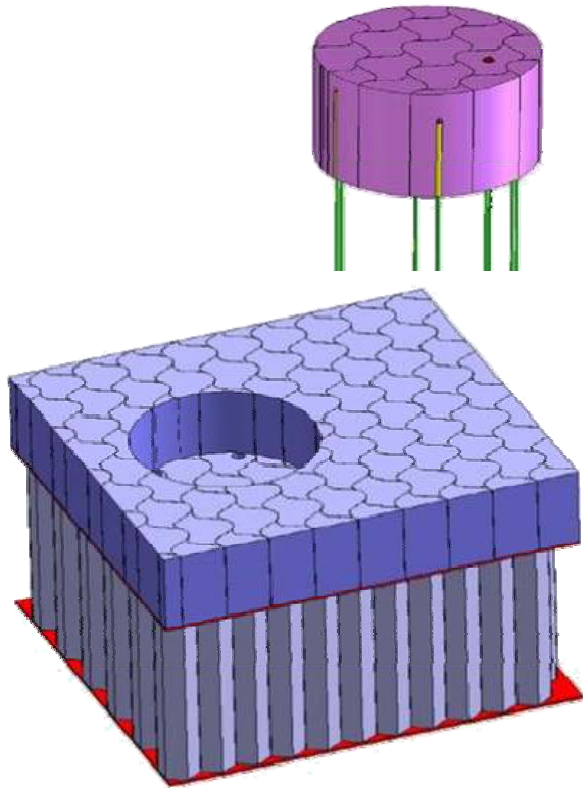

Figure 5. MISP Plug and Acreage TPS/heatshield structure cavity.

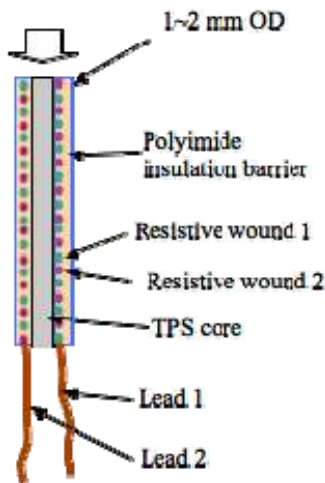

Figure 6. Schematic of HEAT sensor.

The TC measurement junctions are aligned with the center axis of the plug. The science measurement range requirement is 100 to 1300 K with an accuracy of ± 2.2

K or 2.0% below 273 K and ± 1.1 K or 0.4% above 273 K. The depth of the TCs with respect to the TPS outer mold line is ± 0.13 mm (0.005"). The near surface TCs are sampled at 8 Hz and the more slowly varying mid-depth and deep TCs are sampled at either 1 or 2 Hz depending on the location. Cold junction temperature measurement is performed at the SSE and data reduction of all sensors measurements is performed during ground post-processing.

The final MISP design and SLA integration process was validated via a series of developmental and risk reduction arc jet tests at the Aerodynamic Heating Facility (AHF) at NASA Ames Research Center.

3.3 MEADS

In order to meet the aerospace measurement objectives, namely, when the free stream dynamic pressure is greater than 100 Pa, enable reconstruction of the dynamic pressure (q_{bar}) within ± 2.0 percent of measured value, reconstruct Mach number within ± 0.1 , reconstruct angle of attack (α) within ± 0.5 degrees, and reconstruct angle of sideslip (β) within ± 0.5 degrees, each MEDLI pressure transducer will be calibrated to produce outputs that are ± 0.5 percent of reading between 850 Pa and 30 kPa.

As shown in Fig. 7, the MEADS subsystem consists of three main components: a port through the TPS, pressure tube and spool through the heatshield structure, and a pressure transducer. Through a series of arc jet tests conducted at the Boeing-St. Louis Large Core Arc Tunnel Facility, the port diameter of 2.54 mm (0.1") in was found to meet the accuracy requirements. Additional testing has also shown that a sleeve through the TPS is not required. Testing found that pyrolysis gases from the TPS did not significantly affect the pressure reading. To simplify the interface to the heatshield, a stainless steel spool provides a clear pathway through the aluminum honeycomb interior. A fitting allows connection to the stainless steel tube. The tube finally connects to the pressure transducer head. The pressure transducer head is mounted through three mounts to standard inserts. The tube, transducer, and fittings require a volume of 76 x 86 x 183 mm (3.0" x 3.4" x 7.2") in the interior of the heatshield. This volume is sufficient to ensure clearance within the heatshield interior. In order to avoid crossing composite sheet interfaces, three configurations with slightly different orientations are required. The entire subsystem is designed to meet 60g launch loads as required by MSL. Standoffs provide clearance for MSL's multi-layer insulating (MLI) blanket located on the interior of the heatshield. The pressure path is simple and requires two flare fitting connections

between the heatshield outer mold line (OML) and the pressure transducer. The selection of stainless steel for the tubing mitigates the risk of burn-through during entry. The pigtail in the tube provides strain relief for mechanical and thermal distortions during launch, cruise, and entry.

Since power is not provided to MEDLI during the cruise phase, the expected thermal environment at the pressure transducer location prohibited incorporating electronics in the head. Through a two wire interface, the pressure reading is transmitted to the SSE where the signal is appropriately conditioned. Key aspects of the transducer specification are shown in Table 3.

Table 3. MEADS Pressure Transducer Specifications

Key Parameter	Specification
Pressure range	0-35kPa (0-5 psia)
Accuracy	0.5% of reading
Temperature range	-225°C to +125°C
Mass	less than 368 grams

Through a Request For Proposal (RFP) acquisition process, a source selection board selected transducers from Stellar Technology Incorporated (STI) that utilize a strain gauge pressure measurement approach. The temperature of each transducer head is also recorded through a TC mounted on each transducer housing.

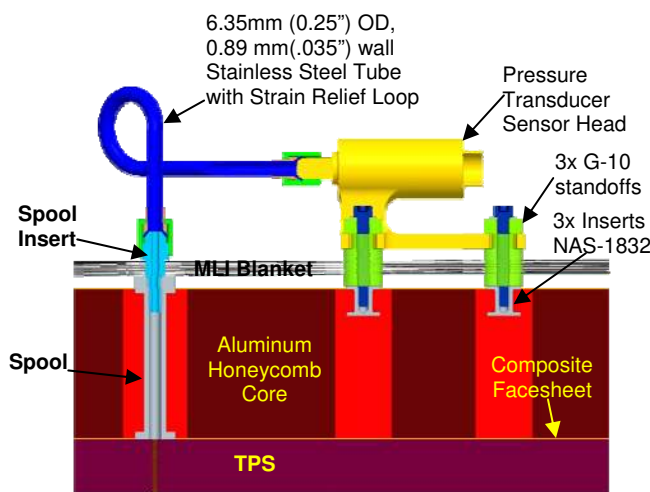

Figure 7. MEADS Overview.

3.4 SSE

The SSE contains two electronic boards housed in a 76.2 × 247.7 × 336.6 mm (3.0" × 9.75" × 13.25") aluminum chassis. The 158.75 × 304.8 mm (6.25" × 12.0") digital board contains the RS-422 interface and power interface to the DPAM. An ACTEL field-programmable gate array will manage the analog-to-digital converter and provide the RS-422 electrical interface. The digital board also provides conditioning of the MSL provided 28V power and conversion to 5.0V and 2.5V power, and contains the pressure transducer signal conditioning electronics. The analog board, also 158.75 × 304.8 mm (6.25" × 12.0") in size, contains the interface for up to 24 thermocouples from the sensor plugs, up to seven thermocouples for the pressure transducers, up to six HEAT sensor inputs, and the pressure transducer signals (conditioned on the digital board). A multiplexer routes all inputs into a single, 14 bit analog-to-digital converter. Each sample is 16 bits wide with two bits reserved for data synchronization. MEDLI will generate approximately 0.9 MBytes during operations. The raw data rate from MEDLI to the DPAM is 4 kilobits per second. The DPAM will add 1/64 second time tags (16 bits each) to each data frame resulting in an additional 225 Kbytes for 30 minutes of operation. The total MEDLI data volume is expected to be 1.13 MBytes. Memory is allocated in the Rover Compute Element (RCE) when MEDLI instrumentation is activated approximately ten minutes before atmospheric interface, and is held until the MEDLI data is transmitted to Earth.

Each of the TC inputs and HEAT inputs use transient voltage suppressors to ensure that sensor anomalies do not damage the processing electronics. In addition to the sensor signals, a series of housekeeping signals including cold junction compensation (CJC) signals, reference voltages, and chassis temperature are recorded. As shown in Table 4, 77 channels are recorded in total.

Table 5 shows the sample strategy for the MISP plugs. The sample rates for each TC were determined based on expected responses from aerothermal and TPS thermal response modeling analysis. In each plug TC1 is the TC nearest the OML (2.54 mm (0.1" depth)) and TC4 is nearest the bondline (15.24 mm (0.6" depth)). The interface to the DPAM limits the number of channels and sample rate. The HEAT sensor from location T4 is at the stagnation point where little recession is expected. Hence, its signal will not be recorded (this channel was employed for additional reference temperature and HEAT calibration measurements). The deeper TCs at locations T5 and T7 will not be recorded because only 24 total TC channels are available, and these four

locations were prioritized lowest in terms of satisfaction of MISP science objectives. However, if any of the 24 primary channels are determined to be nonfunctional during pre-launch checks, one of the deep TCs at T5 or T7 can be connected instead.

The SSE chassis design is largely driven by thermal requirements. Standoffs provide thermal isolation from the cold heatshield and provide clearance for MSL's interior MLI blanket. The SSE location was chosen to minimize interference with the MSL rover and located under the rover's Radioisotope thermoelectric generator (RTG) to take advantage of the thermal energy provided by the RTG, especially during the cruise phase when no power is provided to MEDLI. The chassis surface will be anodized black to provide high thermal absorption and reduce glint. For ease of cable routing, one side of the chassis will house all sensor connections, while the opposite side will house all descent stage connections. The box will be vented through a 0.2 micron high efficiency particulate air (HEPA) filter to allow pressurization equalization and meet planetary protection requirements.

4 SUMMARY

Authorized by NASA in 2006, MEDLI is the most recent effort to acquire much need EDL flight data from planetary probe missions. Expected to enter the Martian atmosphere in 2010, MEDLI instrumentation, installed in the entry vehicle of MSL, will provide thermal, recession, and pressure data that will capture important measurements of the aerothermal environments, sub-surface heatshield material response, vehicle orientation, and atmospheric density of the Martian atmosphere. The flight science objectives of MEDLI directly address the largest uncertainties in the ability to design and validate a robust Mars entry system, including aerothermal, aerodynamic and atmosphere models, and thermal protection system design.

Table 4. Channel Allocation.

Sensor Type	Number of Channels	Sample Rate
Thermocouple	12	8 Hz
Thermocouple	4	2 Hz
Thermocouple	8	1 Hz
Thermocouple Baseline Reference	4	1 Hz
Thermocouple Local Calibration	4	1 Hz
Heat Sensors	6	8 Hz
Heat Sensor Local Calibration	2	1 Hz
Pressure Sensors	7	8 Hz
Pressure Baseline Reference	1	1 Hz
Pressure Temperatures	7	1 Hz
Pressure Temp Baseline Reference	1	1 Hz
CJC Temperatures	3	1 Hz
Housekeeping Temperatures	3	1 Hz
Temperature Local Calibration	2	1 Hz
Housekeeping Voltages	8	1 Hz
On-board Reference Voltages	5	1 Hz
Total	77	

Table 5. MISP Sample Strategy

Plug ID	TC1	TC2	TC3	TC4	HEAT
T1	8 Hz	8 Hz	1 Hz	1 Hz	8 Hz
T2	8 Hz	8 Hz	2 Hz	2 Hz	8 Hz
T3	8 Hz	8 Hz	1 Hz	1 Hz	8 Hz
T4	8 Hz	8 Hz	1 Hz	1 Hz	None
T5	8 Hz	8 Hz	None	None	8 Hz
T6	8 Hz	8 Hz	1 Hz	1 Hz	8 Hz
T7	2 Hz	2 Hz	None	None	8 Hz

5 REFERENCES

1. Wright, M.J., Milos, F.S., and Tran, P., "Afterbody Aeroheating Flight Data for Planetary Probe Thermal Protection System Design," *Journal of Spacecraft and Rockets*, Vol. 43, No. 5, 2006, pp. 929-943.
2. Pruett, C. D., Wolf, H., Heck, M. L., and Siemers III, P.M., "Innovative Air-Data System for the Space Shuttle Orbiter," *Journal of Spacecraft and Rockets*, Vol. 20, No. 1, 1983, pp. 61-69.
3. Seiff, A., and Kirk, D., "Structure of the Atmosphere of Mars in Summer at Mid-Latitudes," *Journal of Geophysical Research*, Vol. 82, Sept. 1977, pp. 4364-4378.
4. Martin-Marietta Corp., "Entry Data Analysis for Viking 1 and 2," NASA CR-159388, Nov. 1976.
5. Edquist, K.T., Wright, M.J., and Allen, G.A., "Viking Afterbody Heating Computations and Comparison to Flight Data," AIAA Paper No. 2006-0386, Jan. 2006.
6. Milos, F., Chen, Y.-K., Congdon, W., and Thornton, J., "Mars Pathfinder Entry Temperature Data, Aerothermal Heating, and Heatshield Material Response," *Journal of Spacecraft and Rockets*, Vol. 36, No. 3, 1999, pp. 380-391.
7. Steltzner, A., Kipp, D., Chen, A., Burkhart, D., Guernsey, C., Mendeck, G., Mitcheltree, R., Powell, R., Rivellini, T., San Martin, M., and Way, D., "Mars Science Laboratory Entry, Descent and Landing System," IEEE Paper No. 2006-1307, Mar. 2006.
8. Edquist, K., Dyakonov, A., Wright, M., and Tang, C., "Aerothermodynamic Environment Definition for the Mars Science Laboratory Entry Capsule," AIAA Paper No. 2007-1206, Jan. 2007.
9. Wright, M.J., Edquist, K.T., Hollis, B.R., Brown, J., and Olejniczak, J., "Review of Aerothermal Modeling for Current and Future Mars Entry Missions," IEEE Paper No. 2006-1428, Mar. 2006.
10. Tolson, R.H., Willcockson, W.H., Desai, P.N., Thomas, P., "Anomalous Disturbance Torques during the Entry Phase of the Mars Exploration Rover Missions - A Telemetry and Mars-Surface Investigation," 29th Annual AAS Guidance and Control Conference, AAS 06-087, February, 2006.
11. Milos, F., Chen, Y.-K., Squire, T., and Brewer, R., "Analysis of Galileo Probe Heatshield Ablation and Temperature Data," *Journal of Spacecraft and Rockets*, Vol. 36, No. 3, 1999, pp. 298-306.
12. Oishi, T., Martinez, E., Fu, J., Santos, J., Mach, J., Gorbunov, S., and Kihara, S., "Development and Application of a TPS Ablation Sensor for Flight," to be presented at the AIAA Aerospace Sciences Meeting, Jan. 2008.