

Parallel phase-shifting digital holographic microscopy

Tatsuki Tahara,¹ Kenichi Ito,¹ Takashi Kakue,¹ Motofumi Fujii,¹ Yuki Shimozato,¹
Yasuhiro Awatsuji,^{1,*} Kenzo Nishio,² Shogo Ura,¹ Toshihiro Kubota,³
and Osamu Matoba⁴

¹Graduate School of Science and Technology, Kyoto Institute of Technology, Matsugasaki, Sakyo-ku, Kyoto, 606-8585, Japan

²Advanced Technology Center, Kyoto Institute of Technology, Sakyo-ku, Kyoto, 606-8585, Japan

³Kubota Holography Laboratory Corporation, Nishihata 34-1-609, Ogura-cho, Uji, Kyoto, 611-0042, Japan

⁴Graduate School of Engineering, Kobe University, Rokkodai 1-1, Nada, Kobe, 657-8501, Japan
*awatsuji@kit.ac.jp

Abstract: We propose parallel phase-shifting digital holographic microscopy (PPSDHM) which has the ability of three-dimensional (3-D) motion measurement using space-division multiplexing technique. By the PPSDHM, instantaneous information of both the 3-D structure and the phase distributions of specimens can be simultaneously acquired with a single-shot exposure. We constructed a parallel phase-shifting digital holographic microscope consisting of an optical interferometer and an image sensor on which micro polarizers are attached pixel by pixel. The validity of the PPSDHM was experimentally verified by demonstrating the single-shot 3-D imaging and phase-imaging ability of the constructed microscope.

©2010 Optical Society of America

OCIS codes: (180.0180) Microscopy; (090.1995) Digital holography; (090.2880) Holographic interferometry; (180.3170) Interference microscopy; (180.6900) Three-dimensional microscopy.

References and links

1. J. W. Goodman, and R. W. Lawrence, "Digital image formation from electronically detected holograms," *Appl. Phys. Lett.* **11**(3), 77–79 (1967).
2. Three-Dimensional Television, Video, and Display Technologies, ed. B. Javidi and F. Okano (Springer, 2002).
3. Digital holography and three-dimensional display: Principles and Applications, ed. T. -C. Poon, (Springer, 2006).
4. Digital Holography, ed., U. Schnars and W. Jueptner (Springer, 2005).
5. T.-C. Poon, K. Doh, B. Schilling, M. Wu, K. Shinoda, and Y. Suzuki, "Three-dimensional microscopy by optical scanning holography," *Opt. Eng.* **34**(5), 1338–1344 (1995).
6. S. S. K. Jericho, J. Garcia-Sucerquia, W. Xu, M. H. Jericho, and H. J. Kreuzer, "Submersible digital in-line holographic microscope," *Rev. Sci. Instrum.* **77**(4), 043706 (2006).
7. J. Sheng, E. Malkiel, J. Katz, J. Adolf, R. Belas, and A. R. Place, "Digital holographic microscopy reveals prey-induced changes in swimming behavior of predatory dinoflagellates," *Proc. Natl. Acad. Sci. U.S.A.* **104**(44), 17512–17517 (2007).
8. B. Javidi, I. Moon, S. Yeom, and E. Carapezza, "Three-dimensional imaging and recognition of microorganism using single-exposure on-line (SEOL) digital holography," *Opt. Express* **13**(12), 4492–4506 (2005), <http://www.opticsinfobase.org/oe/abstract.cfm?URI=oe-13-12-4492>.
9. B. Javidi, S. Yeom, I. Moon, and M. Daneshpanah, "Real-time automated 3D sensing, detection, and recognition of dynamic biological micro-organic events," *Opt. Express* **14**(9), 3806–3829 (2006), <http://www.opticsinfobase.org/oe/abstract.cfm?URI=oe-14-9-3806>.
10. E. Y. Lam, X. Zhang, H. Vo, T.-C. Poon, and G. Indebetouw, "Three-dimensional microscopy and sectional image reconstruction using optical scanning holography," *Appl. Opt.* **48**(34), H113–H119 (2009).
11. E. Cuhe, P. Marquet, and C. Depeursinge, "Simultaneous amplitude-contrast and quantitative phase-contrast microscopy by numerical reconstruction of Fresnel off-axis holograms," *Appl. Opt.* **38**(34), 6994–7001 (1999).
12. F. Dubois, L. Joannes, and J. C. Legros, "Improved three-dimensional imaging with a digital holography microscope with a source of partial spatial coherence," *Appl. Opt.* **38**(34), 7085–7094 (1999).
13. I. Yamaguchi, and T. Zhang, "Phase-shifting digital holography," *Opt. Lett.* **22**(16), 1268–1270 (1997).
14. T. Zhang, and I. Yamaguchi, "Three-dimensional microscopy with phase-shifting digital holography," *Opt. Lett.* **23**(15), 1221–1223 (1998).
15. M. Sasada, Y. Awatsuji, and T. Kubota, "Parallel quasi-phase-shifting digital holography that can achieve instantaneous measurement," in *Technical Digest of the 2004 ICO International Conference: Optics and Photonics in Technology Frontier (International Commission for Optics, 2004)*, (Chiba, 2004) pp. 187–188.

16. M. Sasada, A. Fujii, Y. Awatsuji, and T. Kubota, "Parallel quasi-phase-shifting digital holography implemented by simple optical set up and effective use of image-sensor pixels," in *Technical Digest of the 2004 ICO International Conference: Optics and Photonics in Technology Frontier (International Commission for Optics, 2004)*, (Chiba, 2004) pp. 357–358.
17. Y. Awatsuji, M. Sasada, and T. Kubota, "Parallel quasi-phase-shifting digital holography," *Appl. Phys. Lett.* **85**(6), 1069–1071 (2004).
18. J. Millerd, N. Brock, J. Hayes, M. North-Morris, M. Novak, and J. Wyant, "Pixelated phase-mask dynamic interferometer," *Proc. SPIE* **5531**, 304–314 (2004).
19. S. Yoneyama, H. Kikuta, and K. Moriwaki, "Instantaneous phase-stepping interferometry using polarization imaging with a micro-retarder array," *Exp. Mech.* **45**(5), 451–456 (2005).
20. T. Nomura, S. Murata, E. Nitanaï, and T. Numata, "Phase-shifting digital holography with a phase difference between orthogonal polarizations," *Appl. Opt.* **45**(20), 4873–4877 (2006).
21. Y. Awatsuji, T. Tahara, A. Kaneko, T. Koyama, K. Nishio, S. Ura, T. Kubota, and O. Matoba, "Parallel two-step phase-shifting digital holography," *Appl. Opt.* **47**(19), D183–D189 (2008).
22. S. Murata, D. Harada, and Y. Tanaka, "Spatial phase-shifting digital holography or three-dimensional particle tracking velocimetry," *Jpn. J. Appl. Phys.* **48**(9), 09LB01 (2009).
23. L. Martínez-León, M. Araiza-E, B. Javidi, P. Andrés, V. Climent, J. Lancis, and E. Tajahuerce, "Single-shot digital holography by use of the fractional Talbot effect," *Opt. Express* **17**(15), 12900–12909 (2009), <http://www.opticsinfobase.org/abstract.cfm?uri=oe-17-15-12900>.
24. T. Kakue, T. Tahara, K. Ito, Y. Shimozato, Y. Awatsuji, K. Nishio, S. Ura, T. Kubota, and O. Matoba, "Parallel phase-shifting color digital holography using two phase shifts," *Appl. Opt.* **48**(34), H244–H250 (2009).
25. T. Kakue, Y. Moritani, K. Ito, Y. Shimozato, Y. Awatsuji, K. Nishio, S. Ura, T. Kubota, and O. Matoba, "Image quality improvement of parallel four-step phase-shifting digital holography by using the algorithm of parallel two-step phase-shifting digital holography," *Opt. Express* **18**(9), 9555–9560 (2010), <http://www.opticsinfobase.org/abstract.cfm?uri=oe-18-9-9555>.
26. T. Tahara, Y. Awatsuji, A. Kaneko, T. Koyama, K. Nishio, S. Ura, T. Kubota, and O. Matoba, "Parallel two-step phase-shifting digital holography using polarization," *Opt. Rev.* **17**(3), 108–113 (2010).
27. H. Suzuki, T. Nomura, E. Nitanaï, and T. Numata, "Dynamic Recording of a Digital Hologram with Single Exposure by a Wave-Splitting Phase-Shifting Method," *Opt. Rev.* **17**(3), 176–180 (2010).
28. X. F. Meng, L. Z. Cai, X. F. Xu, X. L. Yang, X. X. Shen, G. Y. Dong, and Y. R. Wang, "Two-step phase-shifting interferometry and its application in image encryption," *Opt. Lett.* **31**(10), 1414–1416 (2006).
29. T. Sato, T. Araki, Y. Sasaki, T. Tsuru, T. Tadokoro, and S. Kawakami, "Compact ellipsometer employing a static polarimeter module with arrayed polarizer and wave-plate elements," *Appl. Opt.* **46**(22), 4963–4967 (2007).

1. Introduction

In recent years, there have been great progresses in life science and biomedical technology. In these fields, multi-parameter imaging technologies are strongly expected. The acquisitions of structure, phase distribution, and dynamics are useful for the various analyses in cell biology, biochemistry, and other life sciences. Microscopic observation and measurement play important roles for the progresses in the fields. However, it is difficult for the conventional optical microscopy to measure change in three-dimensional (3-D) structure or 3-D behavior of dynamically moving specimens due to the requirement for mechanical focusing process. Although confocal laser microscopy is frequently used for measuring a 3-D structure, 3-D measurement for dynamic specimen or phenomena is difficult due to laser beam scanning or moving the stage. Furthermore, phase imaging of the dynamically moving specimen is quite difficult impossible for confocal microscopy.

To overcome the drawbacks, digital holography has been actively researched recently [1–4]. In digital holography, an image sensor records an interference fringe image which contains 3-D information of objects. The interference fringe image is called hologram. 3-D image of objects can be reconstructed by numerically processing the single hologram. Thus, digital holography is capable of 3-D measurement for moving objects. This technique has such the attractive features: focused images of 3-D objects at a desired depth can be acquired without any mechanical focusing process, 3-D images of specimens can be measured without chemically labeling and stimulation, and both amplitude image and phase image can be acquired simultaneously. Digital holographic microscopy (DHM) [4–12] is used for analyzing and imaging 3-D motions as a 4-D microscopy with deep depth of field [7].

Because the pixel pitch of the image sensor is larger than interference fringes in general, in-line digital holography in which both an object wave and a reference wave perpendicularly illuminate an image sensor is mainly adopted [4–10]. However, unwanted images called as the 0-th order diffraction wave and the conjugate image are superimposed on the 3-D image

of objects, and then the image quality is degraded. Phase-shifting digital holography (PSDH) [13,14] was proposed as a technique capable of obtaining high-quality 3-D image free from unwanted images. However, instantaneous 3-D measurement is impossible for PSDH because sequential recording of several holograms is required.

To acquire instantaneous 3-D image of object free from the unwanted images, parallel phase-shifting digital holography (PPSDH) [15–27] was proposed. Thanks to space-division multiplexing of holograms, PPSDH is capable of reconstructing high-quality 3-D image and achieving instantaneous 3-D measurement. By PPSDH, the image sensor simultaneously records the information of several holograms required for PSDH, so that PPSDH has potential of 3-D motion picture (4-D image) measurement. However, parallel phase-shifting digital holographic microscopy (PPSDHM) has not been reported yet. In this Letter, we propose the PPSDHM and construct a PPSDH microscope for the first time, and the validity of the PPSDHM is experimentally demonstrated. To implement a microscope based on PPSDH, we made the optical system located between microscope objectives and a digital camera compact. Then we used an image sensor, on which a micro-polarizer array was attached, in in-line DHM to generate two kinds of phase distributions of a reference wave.

2. Parallel phase-shifting digital holographic microscopy (PPSDHM)

Figure 1(a) shows a block diagram of the PPSDHM. A perpendicularly polarized light beam is emitted from the laser and is split into two beams by a beam splitter. One beam illuminates the specimen, and then the scattered light from the specimen is collected by a microscope objective. Through the polarizer which passes perpendicularly polarized light, the collected light arrives at the image sensor of the digital camera as the object wave. The other beam passes through the other microscope objective and the quarter wave plate (QWP), and then arrives at the image sensor as the reference wave. The micro-polarizer array is attached on the image sensor pixel by pixel to implement 90° phase-shift of the reference wave as shown in Fig. 1(b). Each cell of the micro-polarizer array corresponds with each pixel of the image sensor. Figure 1(c) shows the polarization orientation of the micro-polarizer array. Transmission axis of each cell is tilted 45° against that of the polarizer placed in the path of the object wave, and parallel or orthogonal to fast or slow axis of the QWP. After passing the micro-polarizer array, the object wave and the reference wave which passes through fast axis of the QWP forms a hologram, and these which passes through slow axis of the QWP forms the other hologram on the image sensor, respectively. Thus, a single image sensor can acquire the information of two phase-shifted holograms required for two-step phase-shifting technique [28] by the PPSDHM with a single-shot exposure. Although Fig. 1(a) shows an optical implementation of PPSDHM for a transparent specimen, PPSDHM can be also implemented for a reflective specimen by changing the configuration of the optical system. In the constructed system, the intensities of the reference waves are different in each hologram when the axes of the polarizers of the array do not correspond with the fast or slow axis of QWP. As a result, the system cannot completely remove the unwanted images by the calculation of the phase-shifting interferometry, and the image quality degrades. Then, the intensity distribution of the reference wave passing through the array of A was adjusted to be equal to those passing through the array of B.

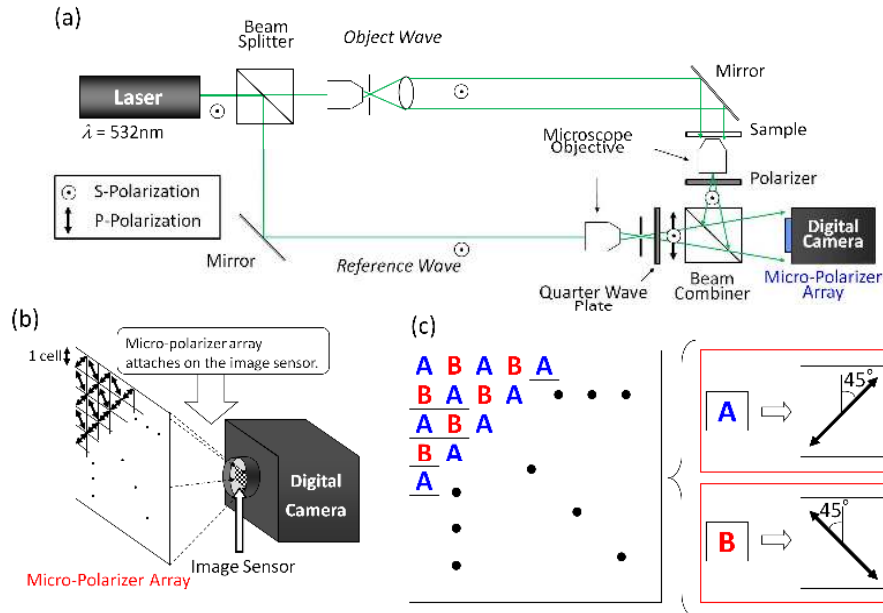

Fig. 1. Schematics of the PPSDHM. (a) An example of the optical implementation, (b) schematic of the image sensor with the micro-polarizer array (c) the configuration of the micro-polarizer array.

Figure 2 shows the processing procedure of image reconstruction of the PPSDHM for the recorded hologram. Two phase-shifted holograms are generated from the recorded hologram. The complex amplitude of the specimen on the image sensor plane is extracted by using the algorithm used in phase-shifting method, and 3-D image of the specimen is obtained. The procedure was described in Ref. 21 in detail. Regardless of whether the focused image of the object is on the image-sensor plane or not, the resolution for the interference fringe is reduced by space-division multiplexing of holograms in the parallel technique. In the system, the resolution for the interference fringe in the $\pm 45^\circ$ direction from horizontal direction is reduced to a half because the pixel pitch is twice in the $\pm 45^\circ$ direction. Therefore, the recordable object size and the resolution are reduced in the $\pm 45^\circ$ direction.

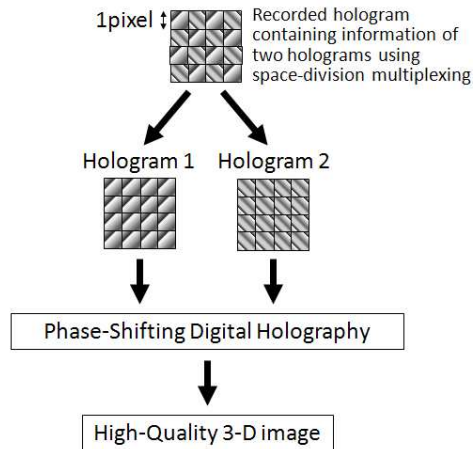

Fig. 2. Processing procedure of the image reconstruction of parallel two-step phase-shifting digital holography.

3. Experimental results

We constructed a PPSDH microscope, and then verified the effectiveness of the PPSDHM. We designed the configuration of the micro-polarizer array shown in Fig. 1(b), and Photonic Lattice, Inc. fabricated the camera. The micro-polarizer array was made of photonic crystal materials [29]. The image sensor has 874 (V) \times 1164 (H) pixels. The microscope photograph of the specimen, scaly hairs of *Elaeagnus*, is shown in Fig. 3. A Nd:YVO₄ laser operated at 532nm was used. Microscope objectives with \times 10 magnification, and N.A. of 0.25 were used.

The experimental results are shown in Fig. 4. Figures 4(a) and 4(b) are the amplitude image and the phase image reconstructed by the PPSDHM. Figures 4(c) and 4(d) are the amplitude and phase images reconstructed by the conventional in-line DHM [4] that requires only a single hologram in the reconstruction. Each image is that numerically focused at 17 mm from the image sensor plane. As seen from Fig. 4, the amplitude image reconstructed by the PPSDHM is much clearer than that by the conventional single-shot in-line DHM that applies Fresnel transform alone. Also, the phase image is clearly reconstructed by the PPSDHM. Thus, the validity of the PPSDHM was successfully demonstrated by the experiment. By analyzing the phase image, instantaneous image measurement of the height or the thickness, and refractive index of specimen can be achieved. The analyses are under way.

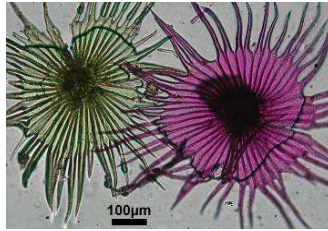

Fig. 3. Microscope photograph of the specimen.

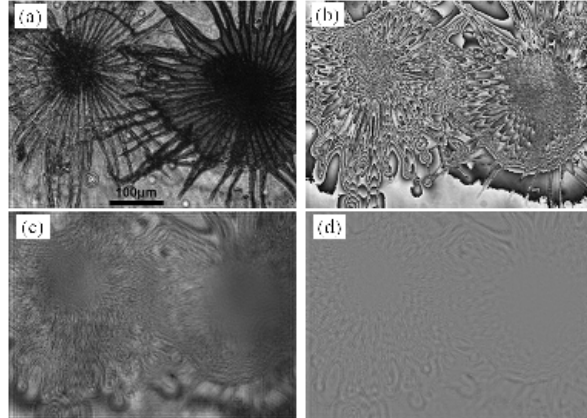

Fig. 4. Reconstructed image by each DHM. (a) Amplitude image, (b) phase image reconstructed by PPSDHM. (c) Amplitude image, (d) phase image reconstructed by the conventional single-shot in-line DHM that applies Fresnel transform alone.

We demonstrate the ability of numerical focusing at a desired depth for single-shot image by PPSDHM. In this study, we applied the diffraction integral at the different depths to the complex amplitude of the object wave obtained by the parallel two-step phase-shifting algorithm reported in Ref. 21 at the image sensor plane for the refocusing. Figures 5(a) and 5(b) show the amplitude images numerically focused at different depths. The images were reconstructed from the same hologram used for reconstructing the image in Fig. 4(a). Figures 6(a)–6(f) show the magnified amplitude images of those focused at different depths.

The magnified areas correspond with that indicated by the rectangles in Fig. 5(a). As shown in Fig. 6, the focused image of a part of the specimen at each depth was clearly reconstructed from the single hologram. The focused image of the particle of 4 μm in diameter was successfully reconstructed, as shown in Fig. 6(b). Thus, the capability of clearly reconstructing the focused images at a desired depth was verified.

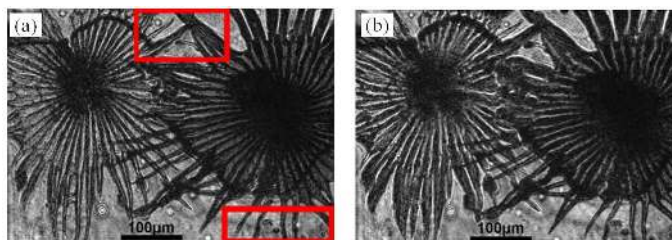

Fig. 5. Reconstructed images by the PPSDHM. Images numerically focused at (a) 19mm, and (b) 22mm from the image sensor plane, respectively.

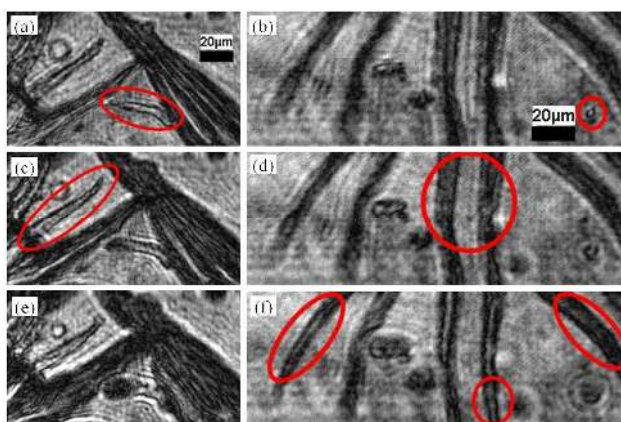

Fig. 6. Magnified images numerically focused at different depths. (a) and (b) are the upper and right bottom parts of the image focused at 17 mm, (c) and (d) are the upper and right bottom parts of the image focused at 19 mm, (e) and (f) are the upper and right bottom parts of the image focused at 22 mm from the image sensor plane, respectively. Insides of the circled ellipsoid areas indicate in-focus areas.

4. Conclusion

We have proposed the PPSDHM which has the ability of high-accuracy instantaneous 3-D image measurement. A PPSDH microscope has been constructed and experimentally demonstrated. Much more high quality image was successfully reconstructed by the PPSDHM in comparison to the image reconstructed by the conventional single-shot in-line DHM, and clear images have been reconstructed at a desired depth from a single hologram.

The 3-D frame rate of the 3-D motion picture obtained by the PPSDHM is equal to the frame rate of digital camera used in the PPSDHM. By using a pulsed laser as a light source, temporal resolution of the 3-D motion picture obtained by PPSDHM is equal to the duration of the pulsed light. Therefore, the PPSDHM is a prospective technique which has the ability of imaging femtosecond order time-dependent changing ultrafast phenomena by using femtosecond pulsed laser. The PPSDHM will be a powerful tool as a 3-D motion picture (4-D) microscopy for imaging and measurement of cell fluid flow, dynamically moving particles, behavior of living cells, biomedical reactions, and so on.

Acknowledgement

This study was partially supported by Industrial Technology Research Grant Program from New Energy and Industrial Technology Development Organization (NEDO) of Japan.