

UNCLASSIFIED

AD NUMBER

ADB139386

LIMITATION CHANGES

TO:

Approved for public release; distribution is unlimited.

FROM:

Distribution authorized to U.S. Gov't. agencies only; Administrative/Operational Use; DEC 1989. Other requests shall be referred to Arnold Engineering Development Center, Arnold AFB, TN.

AUTHORITY

AEDC ltr 3 Feb 1992

THIS PAGE IS UNCLASSIFIED

FEB 15 1990

AEDC-TR-89-15
C#5

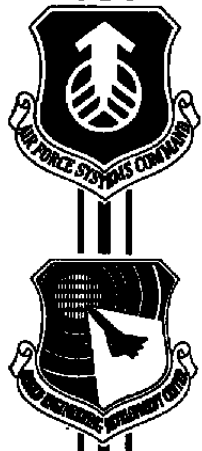

PARC Code: Theory and Usage

G. K. Cooper and J. R. Sirbaugh
Sverdrup Technology, Inc.

December 1989

Final Report for Period July 1, 1985 — June 30, 1989

Approved for public release; distribution unlimited.

~~Distribution authorized to U. S. Government agencies and their contractors, administrative and operational use, December 1989. Other requests for this document shall be referred to Arnold Engineering Development Center/DGGS, Arnold Air Force Base, TN 37389-5000.~~

WARNING
~~This document contains technical data whose export is restricted by the Arms Export Control Act (Title 22, U.S.C., Sec. 2754, et seq.) or The Export Administration Act of 1979, as amended (50 U.S.C. App. 2401, et seq.). Violations of these export laws are subject to severe criminal penalties. Disseminate in accordance with the provisions of AFR 89-34.~~

**ARNOLD ENGINEERING DEVELOPMENT CENTER
ARNOLD AIR FORCE BASE, TENNESSEE
AIR FORCE SYSTEMS COMMAND
UNITED STATES AIR FORCE**

**TECHNICAL REPORTS
FILE COPY**

**PROPERTY OF U.S. AIR FORCE
AEDC TECHNICAL LIBRARY**

12/1989

NOTICES

When U. S. Government drawings, specifications, or other data are used for any purpose other than a definitely related Government procurement operation, the Government thereby incurs no responsibility nor any obligation whatsoever, and the fact that the Government may have formulated, furnished, or in any way supplied the said drawings, specifications, or other data, is not to be regarded by implication or otherwise, or in any manner licensing the holder or any other person or corporation, or conveying any rights or permission to manufacture, use, or sell any patented invention that may in any way be related thereto.

Qualified users may obtain copies of this report from the Defense Technical Information Center.

References to named commercial products in this report are not to be considered in any sense as an endorsement of the product by the United States Air Force or the Government.

DESTRUCTION NOTICE

For classified documents, follow the procedures in DoD 5220.22-M, Industrial Security Manual, Section II-19 or DoD 5200.1-R, Information Security Program Regulation, Chapter IX. For unclassified, limited documents, destroy by any method that will prevent disclosure or reconstruction of the document.

APPROVAL STATEMENT

This report has been reviewed and approved.



MARK S. BRISKI, Capt, USAF
Directorate of Technology
Deputy for Operations

Approved for publication:

FOR THE COMMANDER

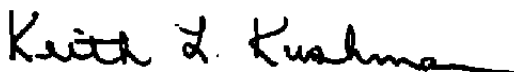

KEITH L. KUSHMAN
Technical Director
Directorate of Technology
Deputy for Operations

REPORT DOCUMENTATION PAGEForm Approved
OMB No. 0704-0188

Public reporting burden for this collection of information is estimated to average 1 hour per response, including the time for reviewing instructions, searching existing data sources, gathering and maintaining the data needed, and completing and reviewing the collection of information. Send comments regarding this burden estimate or any other aspect of this collection of information, including suggestions for reducing this burden, to Washington Headquarters Services, Directorate for Information Operations and Reports, 1215 Jefferson Davis Highway, Suite 1204, Arlington, VA 22202-4302, and to the Office of Management and Budget, Paperwork Reduction Project (0704-0188), Washington, DC 20503.

| | | | | |
|--|---|--|---|--|
| 1. AGENCY USE ONLY (Leave blank) | | 2. REPORT DATE December 1989 | 3. REPORT TYPE AND DATES COVERED Final Report for July 1, 1985 - June 30, 1989 | |
| 4. TITLE AND SUBTITLE PARC Code: Theory and Usage | | | 5. FUNDING NUMBERS PE - 65807F | |
| 6. AUTHOR(S) Cooper, G. K. and Sirbaugh, J. R., Sverdrup Technology, Inc., AEDC Group | | | | |
| 7. PERFORMING ORGANIZATION NAME(S) AND ADDRESS(ES) Arnold Engineering Development Center/DOT Air Force Systems Command Arnold Air Force Base, TN 37389-5000 | | | 8. PERFORMING ORGANIZATION REPORT NUMBER AEDC-TR-89-15 | |
| 9. SPONSORING/MONITORING AGENCY NAME(S) AND ADDRESS(ES) Arnold Engineering Development Center/DO Air Force Systems Command Arnold Air Force Base, TN 37389-5000 | | | 10. SPONSORING/MONITORING AGENCY REPORT NUMBER | |
| 11. SUPPLEMENTARY NOTES Available in Defense Technical Information Center (DTIC). | | | | |
| 12a. DISTRIBUTION/AVAILABILITY STATEMENT Distribution authorized to U. S. Government agencies and their contractors; administrative and operational use; December 1989. Other requests for this document shall be referred to Arnold Engineering Development Center/DOCS, Arnold Air Force Base, TN 37389-5000. | | | 12b. DISTRIBUTION CODE | |
| 13. ABSTRACT (Maximum 200 words) The PARC code is a general purpose flow simulation computer program. It is based on the NASA Ames-developed ARC code and has been extensively enhanced for usage in an applications-oriented environment. A wide variety of flows may be simulated, including those with complex geometries (e.g., aircraft forebody and inlet in a wind tunnel) and those with complex fluid dynamics (e.g., turbulent wall jet). Flow simulations may be two-dimensional, axisymmetric, or three-dimensional; also, they may be inviscid, laminar, or turbulent. Generalized boundary conditions may be located anywhere within the computational grid. Flow geometries may be treated by blocks so that the grid-generation process is simplified, and very complex problems may be simulated. This flow-simulation program has proven to be a very versatile and robust tool for the analysis of engineering problems involving fluid flows. | | | | |
| 14. SUBJECT TERMS fluid flow simulator PARC code ARC code computational fluid dynamics Navier-Stokes solver Euler solver | | | 15. NUMBER OF PAGES 154 | |
| | | | 16. PRICE CODE | |
| 17. SECURITY CLASSIFICATION OF REPORT UNCLASSIFIED | 18. SECURITY CLASSIFICATION OF THIS PAGE UNCLASSIFIED | 19. SECURITY CLASSIFICATION OF ABSTRACT UNCLASSIFIED | 20. LIMITATION OF ABSTRACT Same as Report | |

COMPUTER GENERATED

Standard Form 298 (Rev. 2-89)
Prescribed by ANSI Std. Z39-18
298-102

PREFACE

The work reported herein was conducted by the Arnold Engineering Development Center (AEDC), Air Force Systems Command (AFSC). The results of the research were obtained by Sverdrup Technology, Inc., AEDC Division, operating contractor for the engine test facilities at AEDC, AFSC, Arnold Air Force Base, Tennessee 37389, under Project Number DB84EW. The Air Force Project Manager was Capt. Mark Briski, DOT. This portion of the research was completed on June 30, 1989, and the manuscript was submitted for publication on November 27, 1989.

CONTENTS

| | <u>Page</u> |
|---|-------------|
| 1.0 INTRODUCTION | 5 |
| 1.1 PARC Code Features | 5 |
| 1.2 Overview | 6 |
| 2.0 PHYSICAL MODELS | 6 |
| 2.1 Nondimensionalization | 7 |
| 2.2 Navier-Stokes Equations | 8 |
| 2.3 Thermodynamic Properties | 12 |
| 2.4 Turbulence Model | 13 |
| 2.5 Metrics | 15 |
| 3.0 COMPUTATIONAL ALGORITHMS | 16 |
| 3.1 Beam and Warming Algorithm | 16 |
| 3.2 Artificial Viscosity | 20 |
| 3.3 Pentadiagonal Formulation | 21 |
| 3.4 Psuedo-Runge-Kutta Algorithm | 30 |
| 3.5 Variable Time Steps | 31 |
| 3.6 Boundary Conditions | 32 |
| 3.7 Metric Evaluation | 36 |
| 4.0 USAGE CONCEPTS | 38 |
| 4.1 Nondimensionalization | 38 |
| 4.2 Grids | 39 |
| 4.3 Blocks | 39 |
| 4.4 Initial Conditions | 44 |
| 4.5 Flow Solvers | 45 |
| 4.6 Artificial Viscosity | 48 |
| 4.7 Time-Step Control | 49 |
| 4.8 Boundary Conditions | 52 |
| 4.9 Output | 61 |
| 5.0 OPERATION | 65 |
| 5.1 Parameter Statements | 65 |
| 5.2 File Usage | 67 |
| 5.3 Restart File | 68 |
| 5.4 Parameter File | 68 |
| REFERENCES | 70 |

ILLUSTRATIONS

| <u>Figure</u> | <u>Page</u> |
|---|-------------|
| 1. Grid Concepts | 73 |
| 2. Boundary Segment Specification Example | 74 |
| 3. Patch Generation Example | 75 |
| 4. Flow-Field Print Segmentation | 76 |

APPENDIXES

| | |
|--|---------|
| A. NAMELIST Parameter Glossary | 77 |
| B. Transportability | 85 |
| C. Error Messages | 86 |
| D. PARC Code Version Differences | 94 |
| E. Examples | 99 |
| NOMENCLATURE | 150 |

1.0 INTRODUCTION

This technical report is an extensive update of the previous identically titled technical report, AEDC-TR-87-24. Although much of the material is the same, it has been reorganized, and a number of new topics have been added. In particular, the sections on boundary conditions and artificial viscosity have been enhanced. The pseudo-Runge-Kutta algorithm section and several new appendixes (See Appendixes A through E) have been added. Incorporation of the blocked grid concept into the PARC code has resulted in changes throughout the TR, especially in the boundary-condition treatment. Appendix D describes the differences between the current version of the PARC code and the version covered in the previous TR. This report accurately reflects the state of the AEDC version of the PARC code as of the fall of 1989.

As with other types of aerospace testing, turbine and rocket engine testing requirements are making escalating demands on computational fluid dynamics (CFD) as a means to reduce the costs and risks involved in test planning, execution, and analysis. Since even the simplest engine test always involves a hot, turbulent, chemically complex exhaust, and since many problems of current interest involve complex, multiple-flow passages, these demands on CFD are very stringent indeed. Although many specialized CFD codes have been developed to treat selected subsets of engine testing problems, there remains a largely unsatisfied requirement for a general purpose CFD tool that is at least qualitatively applicable to the bulk of engine testing needs. The PARC Navier-Stokes code was developed for use within the Engine Test Facility (ETF) at the Arnold Engineering Development Center (AEDC) with this in mind. This computer program has proven capable of treating many propulsion testing problems (e.g., thrust-reversing engine exhaust collector design and free-jet test design for inlet icing studies) that could not be dealt with otherwise. This report provides the background and technical details necessary for the proper use of this Navier-Stokes code.

1.1 PARC CODE FEATURES

The PARC code is a flow-field simulation program, which calculates the thermodynamic and kinematic properties of a fluid flow at discrete points within the flow based on a specified boundary geometry and appropriate flow conditions on these boundaries. The boundaries can be very complex, and the fluid can be treated fairly generally. Inviscid and viscous flows can be calculated. Viscous flows can be laminar or turbulent and can be treated as fully viscous or as shear-layer flows. These programs may be used to simulate steady-state and transient flows and are available in a two-dimensional (2-D)/axisymmetric version and a fully three-dimensional (3-D) version. Although the PARC codes are written in FORTRAN 77, they use a number of CRAY® extensions that may not be supported on other scientific computers (See Appendix B). This program is fairly easy to use and does not require more than a good

engineering background to use and abuse it. Although it is not necessary, it is highly recommended that its use be associated with personnel versed in the science and art of CFD. This report has been written based upon this assumed usage. Thus, the theory sections do not seek to teach CFD, only to state particular applications of theory. On the other hand, the usage sections should be understandable to any well-motivated individual who is familiar with computers and is conversant in the theory of fluid flows.

1.2 OVERVIEW

The first section (Physical Models) sketches out the basic physical and mathematical concepts used in the PARC code. The nondimensionalization used is reviewed; the Navier-Stokes equations in both Cartesian and curvilinear coordinates are noted; and the auxiliary relations are presented. A brief discussion is included on the turbulence model used in the PARC code. The next section (Computational Algorithms) reviews the numerical methods of the PARC code. The discretization, artificial viscosity formulation and solution algorithms are treated first. A discussion is included on the various variable time-step options. Then the numerical treatment of the boundary conditions and metrics are covered. Basic usage background information is presented in the next section (Usage Concepts). Material covered includes nondimensionalization requirements, grid notions, the grid-blocking concept, and the generation of initial conditions. Also, the practical aspects of the specification of viscous flow and artificial viscosity parameters, and the proper understanding of the time-step options is presented. This section concludes with coverage of boundary-condition construction and output specifications. The Operation section of this report steps the PARC code user through the use of this program. PARAMETER statement modification, input file usage and input file contents are covered.

2.0 PHYSICAL MODELS

The basis of the algorithms used in the PARC code is the complete Navier-Stokes equations in conservation law form. That is, the divergence form of the time-dependent continuity, momentum, and energy equations is at the heart of the physics embodied in this code. To reduce the complexity and computer memory requirements of this code, the 2-D, axisymmetric, and 3-D specializations of the Navier-Stokes equations are treated in two separate versions of the PARC program (PARC2D and PARC3D, respectively). Various additional specializations are provided for within each of these programs. For example, the viscous terms can be selectively calculated so that a thin-layer simulation can be performed or an inviscid (Euler) flow-field calculation. Similarly, for viscous simulations the fluid flow can be treated as laminar or turbulent as desired. Turbulent flow is calculated by considering the Navier-Stokes equations as having been Reynolds-averaged (mass-averaged) and by using an algebraic turbulence model to determine a turbulent viscosity. The viscous coefficients are determined

from Sutherland's viscosity law, Stokes hypothesis, and an assumption that the Prandtl number is constant.

2.1 NONDIMENSIONALIZATION

Definitions of fluid property notation and the associated nondimensionalizing parameters are contained in the following table:

| <u>Property</u> | <u>Notation</u> | <u>Nondimensionalizing Parameter</u> |
|---------------------------------|-----------------|--|
| Density | ρ | ρ_r |
| Pressure | p | $\rho_r a_r^2$ |
| Temperature | T | T_r |
| Internal Energy per Unit Mass | e | a_r^2 |
| First Coefficient of Viscosity | μ | μ_r |
| Second Coefficient of Viscosity | λ | μ_r |
| Thermal Conductivity | K | K_r |
| Velocity Components | u_i | a_r |
| Cartesian Coordinates | X_i | X_r |
| Time | t | X_r/a_r |

In this table, the r subscript indicates an arbitrary reference fluid state, and a_r is the corresponding reference sound speed. The following dimensionless parameters are also required:

$$Re = \rho_r a_r X_r / \mu_r$$

$$Pr = C_{pr} \mu_r / K_r$$

$$\beta_r = a_r^2 / C_{pr} T_r$$

where C_{pr} = reference specific heat at constant pressure.

When convenient, the following aliases will be used for the velocity and coordinate components:

$$X_1 = X \quad u_1 = u$$

$$X_2 = Y \quad u_2 = v$$

$$X_3 = Z \quad u_3 = w$$

2.2 NAVIER-STOKES EQUATIONS

Although many simplified versions of the Navier-Stokes equations have been successfully applied to various propulsion testing problems, in general these very complex fluid flows can only be adequately treated by the full set of equations. However, because of certain unresolved problems in turbulence modeling, constraints imposed by the numerical technique, and the desirability of keeping the analysis as simple as possible, a number of assumptions and restrictions are required. This section will present the particular forms of the Navier-Stokes equations used in the formulation of the PARC code.

2.2.1 Cartesian Conservation Law Form

The governing differential equations used to model propulsion-related fluid flows are the Reynolds-averaged Navier-Stokes equations for a Newtonian fluid that obey a Fourier heat-conduction law. This system of partial differential equations (continuity, momentum, and energy equations) can be expressed in the following nondimensional conservation law form:

$$\frac{\partial Q}{\partial t} + \frac{\partial F_j}{\partial X_j} = \frac{1}{Re} \frac{\partial G_j}{\partial X_j}$$

where Q is a vector containing the conservation variables,

$$Q = \begin{bmatrix} e \\ \rho u_i \\ E \end{bmatrix}$$

The F_j vectors represent the inviscid flux vectors,

$$F_j = \begin{bmatrix} \rho u_j \\ \rho u_i u_j + P \delta_{ij} \\ (E + P)u_j \end{bmatrix}$$

and the viscous flux vectors (G_j) are

$$G_j = \begin{bmatrix} 0 \\ \tau_{ij} \\ u_k \tau_{jk} - q_j \end{bmatrix}$$

For a Newtonian fluid, the viscous stress tensor takes the form,

$$\tau_{ij} = \mu \left(\frac{\partial u_i}{\partial X_j} + \frac{\partial u_j}{\partial X_i} \right) + \lambda \frac{\partial u_k}{\partial X_k} \delta_{ij}$$

Assuming a Fourier heat-conduction law, the heat flux vector is

$$q_j = -\frac{K}{\beta_r Pr} \frac{\partial T}{\partial X_j}$$

The total energy per unit volume, E , is defined to be

$$E = e \left(e + \frac{1}{2} u_k u_k \right)$$

For notational convenience, use has been made of the Kronecker delta,

$$\delta_{ij} = \begin{cases} 1, & \text{if } i = j \\ 0, & \text{if } i \neq j \end{cases}$$

and of the Einstein summation convention,

$$u_k u_k = \sum_{j=1}^N u_j u_j$$

(that is, repeated indices in a product indicate summation over the range of the indices). The indices range from 1 to 2 for 2-D and axisymmetric formulations and from 1 to 3 for 3-D formulations. Although this mixed vector-Cartesian tensor notation is very compact, it can also be obtuse. Example expansions in pure vector notation for 2-D would be

$$Q = \begin{bmatrix} e \\ \rho u \\ \rho v \\ E \end{bmatrix} \quad F_1 = \begin{bmatrix} \rho u \\ \rho u^2 + P \\ \rho uv \\ (E + P)u \end{bmatrix}$$

$$G_2 = \begin{bmatrix} 0 \\ \mu (u_y + v_x) \\ 2\mu v_y + \lambda (u_x + v_y) \\ \mu[u(u_y + v_x) + 2v v_y] + \lambda v (u_x + v_y) + \frac{K}{\beta_r Pr} T_y \end{bmatrix}$$

where the following subscript notation has been and will be used to denote partial differentiation, when convenient:

$$u_x = \frac{\partial u}{\partial X}$$

$$u_y = \frac{\partial u}{\partial Y}$$

$$u_z = \frac{\partial u}{\partial Z}$$

2.2.2 Curvilinear Coordinate Conservation Law Form

To allow for the easy discretion of these equations on arbitrary grids, it is advantageous to re-express the Navier-Stokes equations in terms of general curvilinear coordinates while retaining the strong conservation law form. The following coordinate transformation is defined:

$$\xi_j = \xi_j (X_i, t)$$

Using this coordinate transformation, the Navier-Stokes equations become

$$\frac{\partial \hat{Q}}{\partial t} + \frac{\partial \hat{F}_j}{\partial \xi_j} = \frac{1}{Re} \frac{\partial \hat{G}_j}{\partial \xi_j}$$

Where the vectors \hat{Q} , \hat{F}_j , and \hat{G}_j are linear combinations of the corresponding Cartesian vectors Q , F_j , and G_j ,

$$\hat{Q} = \frac{1}{J} Q$$

$$\hat{F}_j = \frac{1}{J} \left(\frac{\partial \xi_j}{\partial t} Q + \frac{\partial \xi_j}{\partial X_k} F_k \right)$$

$$\hat{G}_j = \frac{1}{J} \frac{\partial \xi_j}{\partial X_k} G_k$$

or, equivalently,

$$\hat{Q} = \frac{1}{J} \begin{bmatrix} \rho \\ \rho u_i \\ E \end{bmatrix}$$

$$\hat{F}_j = \frac{1}{J} \begin{bmatrix} \rho U_j \\ \rho u_i U_j + P \frac{\partial \xi_j}{\partial X_i} \\ (E + P) U_j - P \frac{\partial \xi_j}{\partial t} \end{bmatrix} \quad \hat{G}_j = \frac{1}{J} \begin{bmatrix} 0 \\ \hat{\tau}_{ij} \\ u_k \hat{\tau}_{jk} - \hat{q}_j \end{bmatrix}$$

The contravariant velocities are defined as

$$U_j = \frac{\partial \xi_j}{\partial t} + u_k \frac{\partial \xi_j}{\partial X_k}$$

Transformed viscous stress tensor and heat flux vector, are given by

$$\hat{\tau}_{ij} = \frac{\partial \xi_j}{\partial X_k} \tau_{ik}$$

$$\hat{q}_j = \frac{\partial \xi_j}{\partial X_k} q_k$$

where the velocity and temperature derivatives are

$$\frac{\partial u_j}{\partial X_j} = \frac{\partial \xi_k}{\partial X_j} \frac{\partial u_i}{\partial \xi_k}$$

$$\frac{\partial T}{\partial X_j} = \frac{\partial \xi_k}{\partial X_j} \frac{\partial T}{\partial \xi_k}$$

The PARC code formulation assumes that the curvilinear coordinates do not vary with time so that the above terms involving derivatives of the coordinates with respect to time do not appear. Spatial coordinate derivatives are collectively termed “metrics,” and the Jacobian of the transformation is denoted by “J.” Wherever it is convenient, the curvilinear coordinates and the contravariant velocities will be referenced by the following aliases:

$$\xi_1 = \xi \quad U_1 = U$$

$$\xi_2 = \eta \quad U_2 = V$$

$$\xi_3 = \xi \quad U_3 = W$$

2.2.3 Axisymmetric Formulation

In addition to a special form of the metrics, implementation of an axisymmetric option requires the following changes to the 2-D equations. A source term must be included in the Y-momentum equation,

$$\text{RHS}_{\text{axi}} = \text{RHS}_{2\text{-d}} + \frac{1}{J_a} \left[P - \frac{1}{\text{Re}} \left(2 \mu \frac{J}{J_a} v + \lambda \nabla_a \cdot \mathbf{u} \right) \right]$$

where

$$J_a = \xi_x \eta_y - \xi_y \eta_x$$

$$\nabla_a \cdot \mathbf{u} = \frac{J}{J_a} v + u_x + v_y$$

Lastly, everywhere the 2-D divergence ($u_x + v_y$) appears in the viscous terms, they are replaced by the axisymmetric divergence.

2.3 THERMODYNAMIC PROPERTIES

Although the PARC code can easily be modified to allow for an arbitrary functional form for the second coefficient of viscosity, Stokes hypothesis has been used in all versions,

$$\lambda = -\frac{2}{3} \mu$$

For a general real gas, the thermodynamic properties are found as functions of density and internal energy,

$$\begin{aligned} P &= P(\rho, e) & \mu &= \mu(\rho, e) \\ T &= T(\rho, e) & K &= K(\rho, e) \end{aligned}$$

However, the current version of the PARC code is based on the assumption of a thermally and calorically perfect gas. The following nondimensional equations of state are used:

$$\begin{aligned} P &= \rho T / \gamma \\ e &= T / \gamma (\gamma - 1) \end{aligned}$$

This allows the pressure and temperature to be expressed simply as functions of the conservation variables,

$$\begin{aligned} P &= (\gamma - 1) \left(E - \frac{1}{2} \rho u_k u_k \right) \\ T &= \gamma (\gamma - 1) \left(E / \rho - \frac{1}{2} u_k u_k \right) \end{aligned}$$

In this case, the ratio of specific heats, γ , is a constant, and $\beta_r = \gamma - 1$. The perfect-gas version of the PARC code also uses the assumption of a constant Prandtl number and the Sutherland viscosity law,

$$\begin{aligned} K &= \mu \\ \mu &= T^{3/2} (1 + T_s) / (T + T_s) \end{aligned}$$

(T_s = the nondimensional Sutherland temperature.)

2.4 TURBULENCE MODEL

The algebraic turbulence model used in the PARC code is loosely based on the Thomas formulation of the Baldwin and Lomax model (Refs. 1 and 2). When turbulence is required, the viscous coefficients are modified as follows:

o

$$\mu_{\text{total}} = \mu + \mu_T$$

$$\frac{K_{\text{total}}}{Pr} = \frac{K}{Pr} + \frac{\mu_T}{Pr_T}$$

where μ_T is the turbulent viscosity and Pr_T is the turbulent Prandtl number. The turbulence model is made up of two major parts, an unbounded flow model and a bounded flow model, both of which are explained in the following sections.

2.4.1 Unbounded Flow

Each coordinate line for each coordinate direction is divided into sections determined by the location of boundaries and vorticity zeros. Within each section the turbulent viscosity is calculated as

$$\mu_T = Re \rho \ell V$$

$$V = \ell \omega$$

$$\ell = \ell_0 [\text{Max}(|u_j|) - \text{Min}(|u_j|)] / \omega_c$$

$$|u_j| = \sqrt{u_k u_k}$$

where ω_c is the value of the vorticity at the point where $|u_j|$ is a maximum, and ℓ_0 is an adjustable constant. The vorticity is defined as usual by

$$\omega = \begin{cases} \sqrt{(w_y - v_z)^2 + (u_z - w_x)^2 + (v_x - u_y)^2} & \text{(For 3-D)} \\ |v_x - u_y| & \text{(For 2-D)} \end{cases}$$

These turbulent viscosity values are smoothed to alleviate sudden changes in viscosity levels.

2.4.2 Bounded Flow

The bounded part of the algorithm is applied near no-slip boundary surfaces and replaces the unbounded flow values with bounded flow values of the turbulent viscosity between the boundary and the point where they match.

©

$$\begin{aligned}
\mu_T &= \text{Re } \rho \ell V \\
\ell &= \ell_0 d (1 - e^{-d+/A+}) \\
d &= \sqrt{(X - X_w)^2 + (Y - Y_w)^2 + (Z - Z_w)^2} \\
d^+ &= \sqrt{\text{Re } \rho_2 \omega d^2 / \mu_w} \\
V &= \ell \omega
\end{aligned}$$

where ℓ_0 is the von Kármán constant, and A^+ is the van Driest constant; variables subscripted by W are evaluated at the boundary.

2.5 METRICS

The term "metrics" is used to refer to the set of all first partial derivatives of the curvilinear coordinates with respect to the Cartesian coordinates. Although they have a precise mathematical definition, their actual evaluation must take into account the numerical scheme in which they are to be used.

It is much more convenient to evaluate the partial derivatives of the Cartesian coordinates with respect to the curvilinear coordinates. The following analytical relations provide the means for deriving the metrics from these derivatives:

3-D

$$\begin{aligned}
J^{-1} &= X_\xi(Y_\eta Z_\zeta - Y_\zeta Z_\eta) + X_\eta(Y_\zeta Z_\xi - Y_\xi Z_\zeta) + X_\zeta(Y_\xi Z_\eta - Y_\eta Z_\xi) \\
\xi_x &= (Y_\eta Z_\zeta - Y_\zeta Z_\eta)J \\
\xi_y &= (Z_\eta X_\zeta - Z_\zeta X_\eta)J \\
\xi_z &= (X_\eta Y_\zeta - X_\zeta Y_\eta)J \\
\eta_x &= (Y_\zeta Z_\xi - Y_\xi Z_\zeta)J \\
\eta_y &= (Z_\zeta X_\xi - Z_\xi X_\zeta)J \\
\eta_z &= (X_\zeta Y_\xi - X_\xi Y_\zeta)J \\
\zeta_x &= (Y_\xi Z_\eta - Y_\eta Z_\xi)J \\
\zeta_y &= (Z_\xi X_\eta - Z_\eta X_\xi)J \\
\zeta_z &= (X_\xi Y_\eta - X_\eta Y_\xi)J
\end{aligned}$$

2-D

$$J^{-1} = X_{\xi}Y_{\eta} - X_{\eta}Y_{\xi}$$

$$\xi_x = Y_{\eta}J$$

$$\xi_y = -X_{\eta}J$$

$$\eta_x = -Y_{\xi}J$$

$$\eta_y = X_{\xi}J$$

Axisymmetric (X-axis on symmetry axis)

$$J^{-1} = (X_{\xi}Y_{\eta} - X_{\eta}Y_{\xi})Y$$

$$\xi_x = YY_{\eta}J$$

$$\xi_y = -YX_{\eta}J$$

$$\eta_x = -YY_{\xi}J$$

$$\eta_y = YX_{\xi}J$$

3.0 COMPUTATIONAL ALGORITHMS

The Beam and Warming approximate factorization algorithm (Ref. 3) is the basis of the steady-state solution scheme of the PARC code. This algorithm is an implicit scheme that solves the set of equations produced by central-differencing the Navier-Stokes equations on a regular grid. Since these equations are formulated in the strong conservation form for a curvilinear set of coordinates, the resulting algorithm is very general with the desirable features of global conservation and shock capturing. Its ADI style formulation makes this implicit scheme economical in comparison to other implicit and explicit formulations. The implementation of the Beam and Warming algorithm into a Navier-Stokes code was first reported by Pulliam and Steger (Ref. 4). This program, known as AIR2D or AIR3D, was then modified by Pulliam (Ref. 5) who diagonalized the implicit matrices for more efficient execution times. He also modified the artificial dissipation so that it was treated completely implicitly and included a Jameson-style second-order term (Ref. 6) for improved shock capturing. This code, termed the ARC2D or ARC3D program, has been in widespread use within the aerodynamics community. The PARC codes, PARC2D and PARC3D, are directly derived from the ARC codes and share many of their principal features.

3.1 BEAM AND WARMING ALGORITHM

The difference scheme used in the PARC code is the approximate factorization algorithm attributable to Beam and Warming. This algorithm is an implicit, first- or second-order time-

accurate, computationally robust scheme for solving the Navier-Stokes equations. Its delta formulation insures the attainment of steady-state solutions, which are independent of the time-step size. The most attractive feature of the algorithm, as modified by Pulliam, is that it forms an ADI type of scheme in which each sweep involves the inversion of a set of scalar pentadiagonal matrices. This algorithm has solved a variety of complex 2-D, axisymmetric, and 3-D problems of importance to propulsion testing applications in a timely manner.

3.1.1 Time Differencing

Although the original Beam and Warming algorithm contained very general time-difference formulas, the current version of the PARC code uses Euler backward differencing,

$$\Delta\hat{Q}^n + \Delta t^n \left(\frac{\partial\hat{F}_j^{n+1}}{\partial\xi_j} - \frac{1}{\text{Re}} \frac{\partial\hat{G}_j^{n+1}}{\partial\xi_j} \right) = 0$$

which has a truncation error on the order of the time-step size Δt^n . The superscript indicates evaluation of the variable at the time t^n ; that is,

$$\hat{Q}^n = \hat{Q}(\xi, t^n)$$

where t^n is the n^{th} time variable in a monotone increasing sequence of time variables. The delta-forward time difference is defined as

$$\Delta\hat{Q}^n = \hat{Q}^{n+1} - \hat{Q}^n$$

3.1.2. Time Linearization

The time-differenced equation cannot be easily solved since the flux vectors are nonlinear functions of the conservation vector. However, the inviscid flux vector may be time linearized by

$$\hat{F}_j^{n+1} \approx \hat{F}_j^n + A_j^n \Delta\hat{Q}^n$$

which has a truncation error on the order of the square of the time-step size. The Jacobian matrix, A_j , is formally derived from vector differentiation,

$$A_j = \frac{\partial\hat{F}_j}{\partial\hat{Q}}$$

The expanded form for a perfect gas is

$$A_j = \begin{bmatrix} 0 & \frac{\partial \xi_j}{\partial X_k} & 0 \\ \frac{\partial \xi_j}{\partial X_i} \phi^2 - u_i U_j & U_j \delta_{ik} + \frac{\partial \xi_j}{\partial X_k} u_i - (\gamma - 1) \frac{\partial \xi_j}{\partial X_i} u_k & (\gamma - 1) \frac{\partial \xi_j}{\partial X_i} \\ (\phi^2 - h) U_j & \frac{\partial \xi_j}{\partial X_k} h - (\gamma - 1) u_k U_j & \gamma U_j \end{bmatrix}$$

where

$$\phi^2 = \frac{\gamma - 1}{2} u_i u_i$$

$$h = \gamma \frac{E}{\rho} - \phi^2$$

The viscous flux vector, \hat{G}_j^{n+1} , could be treated similarly, but, in the current version of the PARC code, is time lagged to allow the formation of the scalar pentadiagonal algorithm. Thus, the linearized form of the time discretion is

$$\left(I + \Delta t \frac{\partial}{\partial \xi_j} A_j^n \right) \Delta \hat{Q}^n = - \Delta t \left(\frac{\partial \hat{F}_j^n}{\partial \xi_j} - \frac{1}{\text{Re}} \frac{\partial \hat{G}_j^n}{\partial \xi_j} \right)$$

where I denotes the identity matrix of appropriate rank.

3.1.3 Approximate Factorization

Since the operator on $\Delta \hat{Q}^n$ in the previous equations contains derivative operators in all spatial directions, the matrix operator that will be formed when the derivatives are replaced by differences will make solution of the resulting block matrix equation computationally expensive. If instead the operator is factored, a series of inexpensive matrix equations with small bandwidth can be solved by

$$\left(I + \Delta t \frac{\partial}{\partial \xi} A_1^n \right) \left(I + \Delta t \frac{\partial}{\partial \eta} A_2^n \right) \left(I + \Delta t \frac{\partial}{\partial \zeta} A_3^n \right) \Delta \hat{Q}^n = - \Delta t \left(\frac{\partial \hat{F}_j^n}{\partial \xi_j} - \frac{1}{\text{Re}} \frac{\partial \hat{G}_j^n}{\partial \xi_j} \right)$$

where the obvious simplification occurs in 2-D. This equation is still formally first-order accurate in time. When the spatial derivatives are replaced by appropriate differences, the following algorithm results:

$$\text{RHS} = -\Delta t \left[\left(\partial_{\xi} \hat{F}_1^n + \delta_{\eta} \hat{F}_2^n + \delta_{\zeta} \hat{F}_3^n \right) - \frac{1}{\text{Re}} \left(d_{\xi} \hat{G}_1^n + d_{\eta} \hat{G}_2^n + d_{\zeta} \hat{G}_3^n \right) \right]$$

$$(\mathbf{I} + \Delta t \delta_{\xi} \mathbf{A}_1^n) \Delta \hat{Q}^{**} = \text{RHS}$$

$$(\mathbf{I} + \Delta t \delta_{\eta} \mathbf{A}_2^n) \Delta \hat{Q}^* = \Delta \hat{Q}^{**}$$

$$(\mathbf{I} + \Delta t \delta_{\zeta} \mathbf{A}_3^n) \Delta \hat{Q}^n = \Delta \hat{Q}^*$$

$$\hat{Q}^{n+1} = \hat{Q}^n + \Delta \hat{Q}^n$$

where the central difference operators are defined

$$\delta_{\xi} \hat{F}_1 = \frac{1}{2} [\hat{F}_1(\xi+1, \eta, \zeta) - \hat{F}_1(\xi-1, \eta, \zeta)]$$

$$\delta_{\eta} \hat{F}_2 = \frac{1}{2} [\hat{F}_2(\xi, \eta+1, \zeta) - \hat{F}_2(\xi, \eta-1, \zeta)]$$

$$\delta_{\zeta} \hat{F}_3 = \frac{1}{2} [\hat{F}_3(\xi, \eta, \zeta+1) - \hat{F}_3(\xi, \eta, \zeta-1)]$$

and

$$d_{\xi} \hat{G}_1 = \hat{G}_1 \left(\xi + \frac{1}{2}, \eta, \zeta \right) - \hat{G}_1 \left(\xi - \frac{1}{2}, \eta, \zeta \right)$$

$$d_{\eta} \hat{G}_2 = \hat{G}_2 \left(\xi, \eta + \frac{1}{2}, \zeta \right) - \hat{G}_2 \left(\xi, \eta - \frac{1}{2}, \zeta \right)$$

$$d_{\zeta} \hat{G}_3 = \hat{G}_3 \left(\xi, \eta, \zeta + \frac{1}{2} \right) - \hat{G}_3 \left(\xi, \eta, \zeta - \frac{1}{2} \right)$$

In evaluating these midpoint values of the \hat{G}_j vectors, $\hat{G}_1(\xi+1/2, \eta, \zeta)$ for example, all quantities are averaged in the direction of the difference, except for derivatives of velocity in this direction, which are central differenced; for example,

$$\begin{aligned} \mu \left(\xi + \frac{1}{2}, \eta, \zeta \right) &= \frac{1}{2} \left[\mu(\xi+1, \eta, \zeta) + \mu(\xi, \eta, \zeta) \right] \\ u_{\eta} \left(\xi + \frac{1}{2}, \eta, \zeta \right) &= \frac{1}{2} \left\{ \frac{1}{2} \left[u(\xi+1, \eta+1, \zeta) - u(\xi+1, \eta-1, \zeta) \right] \right. \\ &\quad \left. + \frac{1}{2} \left[u(\xi, \eta+1, \zeta) - u(\xi, \eta-1, \zeta) \right] \right\} \end{aligned}$$

$$w_{\xi} \left(\xi + \frac{1}{2}, \eta, \zeta \right) = w(\xi+1, \eta, \zeta) - w(\xi, \eta, \zeta)$$

3.2 ARTIFICIAL VISCOSITY

Because of the central difference nature of this scheme, some artificial viscosity is necessary for stability and for suppression of cosmetic blemishes. The Jameson-style artificial viscosity model used in the PARC code is

$$\begin{aligned} \nabla_{\xi} \left[C_{\xi} \left(\epsilon^{(2)} \Delta_{\xi} - \epsilon^{(4)} \Delta_{\xi} \nabla_{\xi} \Delta_{\xi} \right) \right] (J\hat{Q}) + \nabla_{\eta} \left[C_{\eta} \left(\epsilon^{(2)} \Delta_{\eta} - \epsilon^{(4)} \Delta_{\eta} \nabla_{\eta} \Delta_{\eta} \right) \right] (J\hat{Q}) \\ + \nabla_{\zeta} \left[C_{\zeta} \left(\epsilon^{(2)} \Delta_{\zeta} - \epsilon^{(4)} \Delta_{\zeta} \nabla_{\zeta} \Delta_{\zeta} \right) \right] (J\hat{Q}) \end{aligned}$$

where the forward and backward difference operators are

$$\Delta_{\xi} Q = Q(\xi+1, \eta, \zeta) - Q(\xi, \eta, \zeta)$$

$$\nabla_{\xi} Q = Q(\xi, \eta, \zeta) - Q(\xi-1, \eta, \zeta)$$

with analogous formulas for the other coordinates. The nonlinear coefficients are given by

$$C_{\xi} = C(\xi+1, \eta, \zeta) + C(\xi, \eta, \zeta)$$

for example, where

$$C = \left[\left(\left| U \right| + a \sqrt{\xi_x^2 + \xi_y^2 + \xi_z^2} \right) + \left(\left| V \right| + a \sqrt{\eta_x^2 + \eta_y^2 + \eta_z^2} \right) + \left(\left| W \right| + a \sqrt{\zeta_x^2 + \zeta_y^2 + \zeta_z^2} \right) \right] \frac{1}{J}$$

The second- and fourth-order coefficients are defined as

$$\epsilon^{(2)} = K_2 \Delta t f$$

$$\epsilon^{(4)} = \text{Max} [0, K_4 \Delta t - \epsilon^{(2)}]$$

And the switch function f has the basic form

$$f = \text{Max} (f_{\xi}, f_{\eta}, f_{\zeta})$$

where

$$f_{\xi} = |P(\xi+1, \eta, \zeta) - 2P(\xi, \eta, \zeta) + P(\xi-1, \eta, \zeta)| / |P(\xi+1, \eta, \zeta) + 2P(\xi, \eta, \zeta) + P(\xi-1, \eta, \zeta)|$$

In actual usage in the PARC code, f is smoothed over immediate neighbor points. The two coefficients K_2 and K_4 have nominally maximum values of 0.25 and 0.64, respectively.

Several options in the PARC code are available to modify the amount of artificial dissipation added to the flow field. One option scales the nonlinear coefficients, C , in strong viscous regions by examining the cell Reynolds number

$$Re_c = \frac{Re \rho |U|}{(\mu + \mu_T) \sqrt{\xi_x^2 + \xi_y^2 + \xi_z^2}}$$

The last option provides for a linear combination of the coefficients as suggested by Siclari (Ref. 7). Thus, the artificial dissipation becomes more a function of the coordinate directions. This is accomplished by defining the following directional coefficients:

$$Apt_{\xi} = (|U| + a \sqrt{\xi_x^2 + \xi_y^2 + \xi_z^2})$$

$$Apt_{\eta} = (|V| + a \sqrt{\eta_x^2 + \eta_y^2 + \eta_z^2})$$

$$Apt_{\zeta} = (|W| + a \sqrt{\zeta_x^2 + \zeta_y^2 + \zeta_z^2})$$

Then, for a given constant, α , with a value between zero and one, the definition of the nonlinear coefficient C , in the previous equation, is replaced by

$$C = Apt_{\xi} \left[1 + \left(\frac{Apt_{\eta}}{Apt_{\xi}} \right)^{\alpha} + \left(\frac{Apt_{\zeta}}{Apt_{\xi}} \right)^{\alpha} \right] \frac{1}{J}$$

when evaluating ξ -differenced terms and similar expressions for the other coordinate differences.

3.3 PENTADIAGONAL FORMULATION

The basic Beam and Warming algorithm requires the solution of a block tridiagonal matrix for each coordinate line in each coordinate direction. This series of block matrix inversions is computationally expensive, especially for 3-D problems where the blocks are 5-by-5 submatrices. When the fourth-order artificial viscosity is included as part of the implicit operator, the solution of a block pentadiagonal matrix equation is required, an even more expensive process. However, it is very desirable to incorporate the fourth-order artificial dissipation since it has proven to aid in shock capturing and in rapid convergence to a steady-state solution.

3.3.1 Diagonalized Algorithm

One way to avoid the expense of solving a block pentadiagonal matrix equation is to uncouple (diagonalize) the equations. This can be done by noting that the flux Jacobian, A_j , has a complete set of real eigenvectors and real eigenvalues so that if A_j is decomposed,

$$A_j = T_j \Lambda_j T_j^{-1} \text{ (No summation here or in what follows),}$$

where Λ_j is the diagonal matrix of eigenvalues of A_j , and T_j is the matrix of right eigenvectors with T_j^{-1} its inverse; then,

$$\left(I + \Delta t \frac{\partial A_j}{\partial \xi_j} \right) = \left(T_j T_j^{-1} + \Delta t \frac{\partial}{\partial \xi_j} T_j \Lambda_j T_j^{-1} \right) \approx T_j \left(I + \Delta t \frac{\partial}{\partial \xi_j} \Lambda_j \right) T_j^{-1}$$

Thus, the diagonalized form of the factored algorithm is

$$T_1 \left(I + \Delta t \frac{\partial}{\partial \xi} \Lambda_1 \right) N_{12} \left(I + \Delta t \frac{\partial}{\partial \eta} \Lambda_2 \right) N_{23} \left(I + \Delta t \frac{\partial}{\partial \zeta} \Lambda_3 \right) T_3^{-1} \Delta \hat{Q} = \text{RHS}$$

where

$$N_{12} = T_1^{-1} T_2$$

$$N_{23} = T_2^{-1} T_3$$

Following Pulliam, the explicit form of the eigenvalue matrices is

$$\Lambda_j = \text{Diag} [U_j, U_j, U_j + a|K_i^j|, U_j - a|K_i^j|] \quad (\text{For 2-D})$$

$$\Lambda_j = \text{Diag} [U_j, U_j, U_j, U_j + a|K_i^j|, U_j - a|K_i^j|] \quad (\text{For 3-D})$$

where

$$K_i^j = \frac{\partial \xi_j}{\partial X_i}$$

$$|K_i^j| = \sqrt{\sum_i K_i^j K_i^j} \text{ (No sum over } j.)$$

The eigenvectors for 2-D are

$$T_j = \begin{bmatrix} 1 & 0 & \alpha & \alpha \\ u & \rho \bar{K}_2^j & \alpha(u + \bar{K}_1^j a) & \alpha(u - \bar{K}_1^j a) \\ v & -\rho \bar{K}_1^j & \alpha(v + \bar{K}_2^j a) & \alpha(v - \bar{K}_2^j a) \\ \frac{\phi^2}{\gamma-1} & \rho(\bar{K}_2^j u - \bar{K}_1^j v) & \alpha\left[\frac{\phi^2+a^2}{\gamma-1} + a\bar{U}_j\right] & \alpha\left[\frac{\phi^2+a^2}{\gamma-1} - a\bar{U}_j\right] \end{bmatrix}$$

$$T_j^{-1} = \begin{bmatrix} (1-\phi^2/a^2) & (\gamma-1)u/a^2 & (\gamma-1)v/a^2 & -(\gamma-1)/a^2 \\ -(\bar{K}_2^j u - \bar{K}_1^j v)/\rho & \bar{K}_1^j/\rho & -\bar{K}_2^j/\rho & 0 \\ \beta(\phi^2 - a\bar{U}_j) & \beta[\bar{K}_1^j a - (\gamma-1)u] & \beta[\bar{K}_2^j a - (\gamma-1)v] & \beta(\gamma-1) \\ \beta(\phi^2 + a\bar{U}_j) & -\beta[\bar{K}_1^j a + (\gamma-1)u] & -\beta[\bar{K}_2^j a + (\gamma-1)v] & \beta(\gamma-1) \end{bmatrix}$$

where

$$\alpha = \rho / \sqrt{2} a$$

$$\beta = 1 / \sqrt{2} \rho a$$

$$\bar{U}_j = U_j / |\bar{K}_1^j|$$

$$\bar{K}_i^j = K_i^j / |K_i^j|$$

In 3-D the eigenvectors are

$$T_j = \begin{bmatrix} \bar{K}_1^j & \bar{K}_2^j \\ \bar{K}_1^j u & \bar{K}_2^j u - \bar{K}_3^j e \\ \bar{K}_1^j v + \bar{K}_3^j e & \bar{K}_2^j v \\ \bar{K}_1^j w - \bar{K}_2^j e & \bar{K}_2^j w + \bar{K}_1^j e \\ \left(\bar{K}_1^j \phi^2 / (\gamma - 1) + e(\bar{K}_3^j v - \bar{K}_2^j w) \right) & \left(\bar{K}_2^j \phi^2 / (\gamma - 1) + e(\bar{K}_1^j w - \bar{K}_3^j u) \right) \end{bmatrix}$$

$$\begin{bmatrix} \bar{K}_3^j & \alpha & \alpha \\ \bar{K}_3^j u + \bar{K}_2^j e & \alpha(u + \bar{K}_1^j a) & \alpha(u - \bar{K}_1^j a) \\ \bar{K}_3^j v - \bar{K}_1^j e & \alpha(v + \bar{K}_2^j a) & \alpha(v - \bar{K}_2^j a) \\ \bar{K}_3^j w & \alpha(w + \bar{K}_3^j a) & \alpha(w - \bar{K}_3^j a) \\ \left(\bar{K}_3^j \phi^2 / (\gamma - 1) + e(\bar{K}_2^j u - \bar{K}_1^j v) \right) & \alpha \left(\frac{\phi^2 + a^2}{\gamma - 1} + a\bar{U}_j \right) & \alpha \left(\frac{\phi^2 + a^2}{\gamma - 1} - a\bar{U}_j \right) \end{bmatrix}$$

$$T_j^{-1} = \begin{bmatrix} \bar{K}_1^j (1 - \phi^2/a^2) - (\bar{K}_3^j v - \bar{K}_2^j w)/e & \bar{K}_1^j z(\gamma - 1)u/a^2 \\ \bar{K}_2^j (1 - \phi^2/a^2) - (\bar{K}_1^j w - \bar{K}_3^j u)/e & \bar{K}_2^j (\gamma - 1) u/a^2 - \bar{K}_3^j/e \\ \bar{K}_3^j (1 - \phi^2/a^2) - (\bar{K}_2^j u - \bar{K}_1^j v)/e & \bar{K}_3^j (\gamma - 1) u/a^2 - \bar{K}_2^j/e \\ \beta(\phi^2 - a\bar{U}_j) & -\beta[(\gamma - 1)u - \bar{K}_1^j a] \\ \beta(\phi^2 + a\bar{U}_j) & -\beta[(\gamma - 1)u + \bar{K}_1^j a] \end{bmatrix}$$

$$\begin{array}{ccc}
 \bar{K}_1^j (\gamma - 1)v/a^2 + \bar{K}_3^j/e & \bar{K}_1^j (\gamma - 1)w/a^2 - \bar{K}_2^j/e & -\bar{K}_1^j (\gamma - 1)/a^2 \\
 \bar{K}_2^j (\gamma - 1)v/a^2 & \bar{K}_2^j (\gamma - 1)w/a^2 - \bar{K}_1^j/e & -\bar{K}_2^j (\gamma - 1)/a^2 \\
 \bar{K}_3^j (\gamma - 1)v/a^2 - \bar{K}_1^j/e & \bar{K}_3^j (\gamma - 1)w/a^2 & -\bar{K}_3^j (\gamma - 1)/a^2 \\
 -\beta[(\gamma - 1)v - \bar{K}_2^j/a] & -\beta[(\gamma - 1)w - \bar{K}_3^j/a] & \beta (\gamma - 1) \\
 -\beta[(\gamma - 1)v + \bar{K}_2^j/a] & -\beta[(\gamma - 1)w + \bar{K}_3^j/a] & \beta (\gamma - 1)
 \end{array}
 \left. \vphantom{\begin{array}{ccc}} \right]$$

Also the mixed matrices, N, are

$$N_{ij}^{-1} = \begin{bmatrix} M_1 & M_2 & -M_3 & bM_4 & -bM_4 \\ M_2 & M_1 & -M_4 & -bM_3 & bM_3 \\ M_3 & M_4 & M_1 & bM_2 & -bM_2 \\ -bM_4 & bM_3 & -bM_2 & b^2(1 + M_1) & b^2(1 - M_1) \\ bM_4 & -bM_3 & bM_2 & b^2(1 - M_1) & b^2(1 + M_1) \end{bmatrix} \quad \text{(For 3-D)}$$

$$N_{ij}^{-1} = \begin{bmatrix} 1 & 0 & 0 & 0 \\ 0 & M_1 & bM_2 & -bM_2 \\ 0 & -bM_2 & b^2(1 + M_1) & b^2(1 - M_1) \\ 0 & bM_2 & b^2(1 - M_1) & b^2(1 + M_1) \end{bmatrix} \quad \text{(For 2-D)}$$

where

$$\begin{aligned}
 \mathbf{b} &= 1/\sqrt{2} \\
 \mathbf{M}_1 &= \sum_i \bar{\mathbf{K}}_i^1 \bar{\mathbf{K}}_i^1 \\
 \mathbf{M}_2 &= \bar{\mathbf{K}}_1^1 \bar{\mathbf{K}}_2^1 - \bar{\mathbf{K}}_2^1 \bar{\mathbf{K}}_1^1 \\
 \mathbf{M}_3 &= \bar{\mathbf{K}}_1^1 \bar{\mathbf{K}}_3^1 - \bar{\mathbf{K}}_3^1 \bar{\mathbf{K}}_1^1 \\
 \mathbf{M}_4 &= \bar{\mathbf{K}}_2^1 \bar{\mathbf{K}}_3^1 - \bar{\mathbf{K}}_3^1 \bar{\mathbf{K}}_2^1
 \end{aligned}$$

Note that the N matrices are strictly functions of the metrics. The steps involved in advancing one time-step then are

$$\begin{aligned}
 \mathbf{T}_1 \Delta \hat{\mathbf{Q}}^{(6)} &= \text{RHS} \\
 [\mathbf{I}(1 + \mathbf{IV}_1) + \Delta t \delta_\xi \Lambda_1] \Delta \hat{\mathbf{Q}}^{(5)} &= \Delta \hat{\mathbf{Q}}^{(6)} \\
 \mathbf{N}_{12} \Delta \hat{\mathbf{Q}}^{(4)} &= \Delta \hat{\mathbf{Q}}^{(5)} \\
 [\mathbf{I}(1 + \mathbf{IV}_2) + \Delta t \delta_\eta \Lambda_2] \Delta \hat{\mathbf{Q}}^{(3)} &= \Delta \hat{\mathbf{Q}}^{(4)} \\
 \mathbf{N}_{23} \Delta \hat{\mathbf{Q}}^{(2)} &= \Delta \hat{\mathbf{Q}}^{(3)} \\
 [\mathbf{I}(1 + \mathbf{IV}_3) + \Delta t \delta_\zeta \Lambda_3] \Delta \hat{\mathbf{Q}}^{(1)} &= \Delta \hat{\mathbf{Q}}^{(2)} \\
 \mathbf{T}_3^{-1} \Delta \hat{\mathbf{Q}} &= \Delta \hat{\mathbf{Q}}^{(1)}
 \end{aligned}$$

where \mathbf{IV}_i is the implicit artificial viscosity operator; for example,

$$\mathbf{IV}_1 = \nabla_\xi [C_\xi (\epsilon^{(2)} \Delta_\xi - \epsilon^{(4)} \Delta_\xi \nabla_\xi \Delta_\xi)] \mathbf{J}$$

The difference equations form a set of scalar pentadiagonal equations; whereas the eigenvector operators form a block diagonal vector equation, both of which are straightforward to solve. The pentadiagonal matrix that would be formed from the first difference equation, for instance, has the form

$$L = \begin{bmatrix} n_1 & 0 & 0 & & \bigcirc \\ m_2 & n_2 & 0 & & \\ \ell_3 & m_3 & n_3 & & \\ & \cdot & & \cdot & \\ & \cdot & & \cdot & \\ & \cdot & & \cdot & \\ & & \ell_j & m_j & n_j \\ & & \cdot & \cdot & \cdot \\ & & \cdot & \cdot & \cdot \\ \bigcirc & & \cdot & \cdot & \cdot \\ & & \ell_j & m_j & n_j \end{bmatrix}$$

$$U = \begin{bmatrix} 1 & X_1 & Y_1 & 0 & & \bigcirc \\ 0 & 1 & X_2 & Y_2 & & \\ & \cdot & & \cdot & & \\ & \cdot & & \cdot & & \\ & & 1 & X_j & Y_j & \\ & & \cdot & \cdot & \cdot & \\ & & \cdot & \cdot & \cdot & \\ & & \cdot & \cdot & \cdot & \\ \bigcirc & & & 1 & X_{j-2} & Y_{j-2} \\ & & & 0 & 1 & X_{j-1} \\ & & & 0 & 0 & 1 \end{bmatrix}$$

Then the elements of these matrices, and in the process, the unknown vector q , are found by the following recursive algorithm:

1. $n_1 = c_1$
 $X_1 = d_1/n_1$
 $Y_1 = e_1/n_1$
 $g_1 = f_1/n_1$
2. $m_2 = b_2$
 $n_2 = c_2 - m_2 X_1$
 $X_2 = (d_2 - m_2 Y_1)/n_2$
 $Y_2 = e_2/n_2$
 $g_2 = (f_2 - m_2 g_1)/n_2$

3. For $j = 3$ to $J-2$:

$$\begin{aligned} \ell_j &= a_j \\ m_j &= b_j - \ell_j X_{j-2} \\ n_j &= c_j - m_j X_{j-1} - \ell_j Y_{j-2} \\ X_j &= (d_j - m_j Y_{j-1})/n_j \\ Y_j &= e_j/n_j \\ g_j &= (f_j - m_j g_{j-1} - \ell_j g_{j-2})/n_j \end{aligned}$$

4.

$$\begin{aligned} \ell_{J-1} &= a_{J-1} \\ m_{J-1} &= b_{J-1} - \ell_{J-1} X_{J-3} \\ n_{J-1} &= c_{J-1} - m_{J-1} X_{J-2} - \ell_{J-1} Y_{J-3} \\ X_{J-1} &= (d_{J-1} - m_{J-1} Y_{J-2})/n_{J-1} \\ g_{J-1} &= (f_{J-1} - m_{J-1} g_{J-2} - \ell_{J-1} g_{J-3})/n_{J-1} \end{aligned}$$

5.

$$\begin{aligned} \ell_J &= a_J \\ m_J &= b_J - \ell_J X_{J-2} \\ n_J &= c_J - m_J X_{J-1} - \ell_J Y_{J-2} \\ g_J &= (f_J - m_J g_{J-1} - \ell_J g_{J-2})/n_J \end{aligned}$$

6.

$$\begin{aligned} q_J &= g_J \\ q_{J-1} &= g_{J-1} - X_{J-1} q_J \end{aligned}$$

7. For $j = J-2$ to 1:

$$q_j = g_j - X_j q_{j+1} - Y_j q_{j+2}$$

The vector g is the unknown vector in the matrix subproblem, $Lg = f$. Note that if $J = 4$, then step 3 is skipped; if $J = 3$ then steps 3 and 4 are skipped (an unnecessary Y_2 will be calculated from a nonexistent e_2 in this case). This algorithm is highly recursive, which makes its efficient calculation through vectorization on current supercomputers impractical. However, by solving many of these matrix equations simultaneously, a high degree of vectorization can be obtained.

3.4 PSUEDO-RUNGE-KUTTA ALGORITHM

An alternate flow solver has been incorporated into the PARC code to improve prediction accuracy for time-dependent flows. The alternate solver is the multistage solver commonly referred to as the Runge-Kutta solver developed by Jameson (See Ref. 7). The solver calculates time-accurate and nontime-accurate (i.e. local time-stepping) solutions using a three-, four-, or five-stage scheme. An implicit residual smoothing option has also been incorporated. The multistage solver operates with the same metrics, Jacobians, boundary conditions, RHS, and

artificial dissipation as the pentadiagonal solver. The four-stage time-stepping scheme has the following form to advance the solution from time-step N to N + 1

$$\begin{aligned} Q(0) &= Q(N) \\ Q(1) &= Q(0) + 1/4 DT RHS(0) \\ Q(2) &= Q(0) + 1/3 DT RHS(1) \\ Q(3) &= Q(0) + 1/2 DT RHS(2) \\ Q(4) &= Q(0) + DT RHS(3) \\ Q(N+1) &= Q(4) \end{aligned}$$

The implicit residual smoothing routines solves the following implicit equation for RHS*:

$$(1 - \epsilon_\xi \partial_\xi^2) (1 - \epsilon_\eta \partial_\eta^2) (1 - \epsilon_\zeta \partial_\zeta^2) RHS^* = RHS$$

where ϵ_ξ , ϵ_η , and ϵ_ζ are smoothing parameters set by the user and ∂_ξ^2 , ∂_η^2 , and ∂_ζ^2 are second difference operators. RHS(0) is then replaced by RHS*. The implicit residual smoothing is done prior to the multistage iteration.

3.5 VARIABLE TIME STEPS

Since the PARC code is set up to solve steady-state problems, using the unsteady formulation of the Navier-Stokes equations only as a means to construct an iterative solution algorithm, a couple of different time-step variation schemes are employed.

3.5.1 Spatial Varying Time Steps

In steady-state calculations using a constant time step, the time-step size is determined by stability considerations. For many problems this step size is set by stability problems in a relatively small part of the flow field (e.g., dense grid regions near a body); the step size could be much larger if this region were excluded. Thus, allowing each point to possess its own optimal time-step size should reduce the total number of iterations to reach steady state.

3.5.1.1 Courant Number Formulation

This approach to selecting variable time-step sizes is based on the idea of using a constant Courant number everywhere. Thus, at each grid point (ξ, η, ζ) ,

$$\Delta t = CFL / \text{Max} (|U_j| + a|K_j|)$$

where CFL is the Courant number. For viscous flows, it has been necessary to add a viscous correction:

$$\Delta t = \text{CFL} / \text{Max}_i \left[(|U_j| + a|K_i^j|) + \frac{2}{\text{Re}} \frac{\mu}{\rho} |K_i^j|^2 \right]$$

3.5.1.2 Jacobian Formulation

An alternate, simpler formulation is also used that is based on the idea that in the vast majority of flows, the flow properties vary over less than an order of magnitude (often only by a small factor), and the metrics vary over many orders of magnitude, thus, the following approximation to the Courant number formula:

$$\Delta t = \Delta t_o / \sqrt{1 + J}$$

3.5.2 Temporal Varying Time Steps

Often a time step, or Courant number, which gives optimal convergence rates over most iterations, causes stability problems over a few iterations; thus, a means for automatic temporal adjustment of the time-step size is desirable. This can be done by observing that implicit methods get into unrecoverable stability trouble when one of the conservation variables jumps to a much too-high or too-low value over one iteration. By limiting the maximum relative change in these variables, stability can be maintained. The following is used in the PARC code:

$$\Delta t = \text{Min} \left[\Delta t_{\text{max}}, \text{MPC} / \text{Max}_{i \text{ v.f.}} \left(\left| \frac{\Delta \rho_e}{\rho} \right| \right) \right]$$

where $\Delta \rho_e$ is the component of RHS corresponding to the continuity equation using unit time step (or Courant number); MPC is a specified maximum relative change allowed; Δt_{max} is the maximum Δt (or CFL) to be used in any case; and Δt should be interpreted as CFL if spatial time-step variation is also used. In addition, a similar formulation involving pressure is used so that the time-step size is limited by either a maximum estimated density or pressure change.

3.6 BOUNDARY CONDITIONS

There are a variety of boundary conditions available for use in the PARC code that are selectable through user inputs. These can be conveniently classified as computational boundaries, symmetry boundaries, solid boundaries, block boundaries, and singular boundaries.

3.6.1 Computational Boundaries

This type of boundary does not exist in the actual flow; it is introduced purely for convenience, usually because the flow domain must be truncated to make it computationally manageable. These boundaries are characterized as presenting no obstacle to the flow. The PARC code treats these boundaries through simplified characteristic equations. Two different, but related, approaches are used. One is optimized for internal flows, and the other for external flows. In both cases the appropriate treatment of a boundary point depends on whether the component of velocity normal to the boundary surface passes into or out of the flow and on whether the corresponding Mach number is supersonic or subsonic.

3.6.1.1 Internal Flows

For the case of subsonic inflow, the flow is assumed to be normal to the boundary, and the total temperature and total pressure (T_o and P_o) are prescribed. The following equations are solved:

$$T_o = T + \frac{\gamma-1}{2} u_N^2$$

$$P = P_o(T/T_o)^{\gamma/\gamma-1}$$

$$c = u_N - P/\rho a$$

where if, for example, the boundary is a surface of constant ξ_j , then

$$u_N = u_i \bar{K}_i^j$$

and C is a characteristic-like variable calculated from the flow-field point just off the boundary. This set of equations is solved for T , P , and u_N (ρa is held constant) by Newton iteration on the equation,

$$\left(\frac{2}{\gamma-1}T_o\right)\left(\frac{P}{P_o}\right)^{\frac{\gamma-1}{\gamma}} + \left(\frac{P_o}{\rho a}\right)^2\left(\frac{P}{P_o}\right)^2 + \left(\frac{2cP_o}{\rho a}\right)\left(\frac{P}{P_o}\right) + \left(c^2 - \frac{2}{\gamma-1}T_o\right) = 0$$

Then, having P , the remaining variables, T and u_N , are found by back substitution into the first set of equations. The velocity components are found from

$$u_i = u_N \bar{K}_i^j$$

If the flow is exiting through the boundary at subsonic velocities, then the static pressure is prescribed, and the density and velocity are extrapolated from upstream. The conservation variables are updated using these values. The same approach is used for supersonic outflow, except the static pressure is also extrapolated.

Frequently, it is desirable to prescribe a certain known mass flux on a computational boundary. This boundary condition is implemented in the PARC code through an algorithm that attempts to impose a specified mass flux through a surface by adjusting the pressure according to

$$P^{n+1} = \left[1 + \alpha (\dot{M}_r - \dot{M}^n) / |\dot{M}_r| \right] P^n$$

where P represents the static pressure for outflow and the total pressure for inflow. The specified mass flux is given by \dot{M}_r , which is positive for inflow and negative for outflow; \dot{M}^n is the current mass flux through the surface and α is a relaxation parameter. Once this pressure is adjusted, the appropriate inflow or outflow condition, as described previously, is applied. Note that this algorithm is ad hoc, and it makes no attempt to be time accurate.

3.6.1.2 External Flows

This algorithm assumes that the computational boundaries are in the far field of the flow. Free-stream values of Mach number, angle of attack, and angle of sideslip are used to determine the flow conditions on this boundary based on locally one-dimensional Riemann invariants for subsonic flow and extrapolation of all variables for supersonic flow. The Riemann invariants are defined as

$$R_1 = u_N - a/(\gamma - 1) \text{ and } R_2 = u_N + a/(\gamma - 1)$$

For outflow, R_1 is fixed at free-stream value, and R_2 , u_t (tangential velocity) and S (entropy) are taken from the interior solution. For inflow, R_1 , u_t , and S are fixed at free-stream values, and R_2 is extrapolated from the interior solution.

3.6.2 Symmetry Boundaries

This boundary condition is determined by extrapolation of density, pressure, and tangent velocity from points adjacent to the boundary. Velocity components are obtained from

$$u_j = u_j^+ - u_t^+ \bar{K}_t^1 \bar{K}_j^1 \text{ (no sum over } i)$$

where the “+” superscript indicates evaluation at the point just off of the boundary surface. A special type of symmetry boundary arises in axisymmetric flows. The axis of symmetry is treated the same as for the symmetry boundary condition except that since the tangential direction is known (positive X-direction), the velocity components are

$$u = u^+$$

$$v = 0$$

3.6.3 Solid Boundaries

All solid boundaries have zero-normal velocity components. This fact is taken advantage of for slip-surface boundaries by using the same algorithm as for symmetry surfaces. For no-slip surfaces, all velocity components are zero, and the pressure is always taken to be that at the first point off of the boundary (first-order representation of zero normal gradient of pressure). There are two subclasses. The adiabatic wall boundary condition treats the temperature in the same way as the pressure (first-order approximation to zero-normal temperature gradient). For the case of isothermal walls, the temperature is prescribed.

3.6.4 Block Boundaries

One of the major features of the PARC code is its ability to treat complex flows by breaking it up into overlapping blocks (See Section 4.3). This is primarily a programming problem except for the question of how to treat block interfaces. Contiguous block interfaces, which require exact matching of overlapping grid points, are simply treated by using straight injection between the blocks. Noncontiguous block interfaces, for which grid points do not match between blocks, are more difficult to handle. Strictly speaking, the best treatment is through use of conservative interpolation. The PARC code uses the simpler bilinear and trilinear interpolation technique between blocks. This is not as accurate, but results in a very general treatment of these boundaries.

3.6.5 Singular Boundaries

These boundaries arise when a computational coordinate line represents a physical point (2-D) or a computational coordinate surface represents a physical line (3-D). In the 2-D case, averages of the flow values one grid line off of the boundary line are imposed on each grid point of the collapsed boundary line. The 3-D case is treated the same as 2-D averaging, except the averaging is performed as a set of independent 2-D averages.

3.7 METRIC EVALUATION

Because it is very desirable to maintain free stream (that is, to have the difference analog of the inviscid flux divergence for a constant property flow to be zero), it is not desirable to evaluate the metrics from simple difference analogs. Instead, if the analogy between the differenced form of the strong conservation law equations and the finite volume form of these equations is exploited, proper behavior of the metric differences can be obtained. For example, the metric term ξ_x/J plays the same role in the difference equations as the area of the ξ -constant surface projected onto the Y-Z plane. This projected area is just the X-component of one-half the cross product of the distance vectors between the diagonals of the cell surface.

3-D

$$\xi_x = \frac{1}{2} [D(0,1,1,Y)D(0,-1,1,Z) - D(0,-1,1,Y)D(0,1,1,Z)]J$$

$$\xi_y = \frac{1}{2} [D(0,1,1,Z)D(0,-1,1,X) - D(0,-1,1,Z)D(0,1,1,X)]J$$

$$\xi_z = \frac{1}{2} [D(0,1,1,X)D(0,-1,1,Y) - D(0,-1,1,X)D(0,1,1,Y)]J$$

$$\eta_x = \frac{1}{2} [D(1,0,1,Y)D(1,0,-1,Z) - D(1,0,-1,Y)D(1,0,1,Z)]J$$

$$\eta_y = \frac{1}{2} [D(1,0,1,Z)D(1,0,-1,X) - D(1,0,-1,Z)D(1,0,1,X)]J$$

$$\eta_z = \frac{1}{2} [D(1,0,1,X)D(1,0,-1,Y) - D(1,0,-1,X)D(1,0,1,Y)]J$$

$$\zeta_x = \frac{1}{2} [D(1,1,0,Y)D(-1,1,0,Z) - D(-1,1,0,Y)D(1,1,0,Z)]J$$

$$\zeta_y = \frac{1}{2} [D(1,1,0,Z)D(-1,1,0,X) - D(-1,1,0,Z)D(1,1,0,X)]J$$

$$\zeta_z = \frac{1}{2} [D(1,1,0,X)D(-1,1,0,Y) - D(-1,1,0,X)D(1,1,0,Y)]J$$

where the difference operator is defined as

$$D(j,k,\ell,X) = \frac{1}{2} [X(\xi+j, \eta+k, \zeta+\ell) - X(\xi-j, \eta-k, \zeta-\ell)]$$

For example, the η_y metric has the formulation

$$\eta_y = \frac{J}{8} \left\{ \left[Z(\xi+1, \eta, \zeta+1) - Z(\xi-1, \eta, \zeta-1) \right] \left[X(\xi+1, \eta, \zeta-1) - X(\xi-1, \eta, \zeta+1) \right] \right. \\ \left. - \left[Z(\xi+1, \eta, \zeta-1) - Z(\xi-1, \eta, \zeta+1) \right] \left[X(\xi+1, \eta, \zeta+1) - X(\xi-1, \eta, \zeta-1) \right] \right\}$$

2-D

$$\xi_x = \frac{1}{2} [Y(\xi, \eta+1) - Y(\xi, \eta-1)]J$$

$$\xi_y = -\frac{1}{2} [X(\xi, \eta+1) - X(\xi, \eta-1)]J$$

$$\eta_x = -\frac{1}{2} [Y(\xi+1, \eta) - Y(\xi-1, \eta)]J$$

$$\eta_y = \frac{1}{2} [X(\xi+1, \eta) - X(\xi-1, \eta)]J$$

Axiallysymmetric

$$\xi_x = \frac{1}{4} [Y(\xi, \eta+1) + Y(\xi, \eta-1)] [Y(\xi, \eta+1) - Y(\xi, \eta-1)]J$$

$$\xi_y = -\frac{1}{4} [Y(\xi, \eta+1) + Y(\xi, \eta-1)] [X(\xi, \eta+1) - X(\xi, \eta-1)]J$$

$$\eta_x = -\frac{1}{4} [Y(\xi+1, \eta) + Y(\xi-1, \eta)] [Y(\xi+1, \eta) - Y(\xi-1, \eta)]J$$

$$\eta_y = \frac{1}{4} [Y(\xi+1, \eta) + Y(\xi-1, \eta)] [X(\xi+1, \eta) - X(\xi-1, \eta)]J$$

Expressions for the Jacobians have not been given since their exact value is not important for inviscid steady-state flow calculations and since their current form is very complicated. Continuing the finite volume analog, the inverse of the Jacobian represents the volume of a computational cell; this approach has been taken in evaluating the Jacobians in the PARC code.

4.0 USAGE CONCEPTS

4.1 NONDIMENSIONALIZATION

Since the PARC code is based on a nondimensionalized set of equations, many of the inputs to and outputs from the code are also nondimensional. Although there is some flexibility in the choice of the reference parameters for nondimensionalizing the flow variables, the following system is recommended:

1. Select reference pressure (P_{ref}), temperature (T_{ref}), and density (ρ_{ref}), such that
 - a. they are consistent with the ideal gas law (necessary); and
 - b. they are realized somewhere in the flow (strongly recommended; ideally they should represent the bulk values for the flow).
2. Select a reference length (X_{ref}) that is typical for the length dimensions of the flow field. For complex flows, the simplest choice is the unit length used in the specification of the geometry (e.g., inches, feet, or meters).
3. Calculate the reference velocity (the reference speed of sound, a_{ref}) from the ideal gas relation ($a_{ref}^2 = \gamma R_g T_{ref}$). Also, determine the reference viscosity, ratio of specific heats, and Prandtl number (μ_{ref} , γ , Pr) based on the reference thermodynamic properties.
4. Form nondimensional input parameters and variables (The subscript d indicates a dimensional variable.):

| | |
|-----------------|---|
| Lengths | $X = X_d / X_{ref}$ |
| Densities | $\rho = \rho_d / \rho_{ref}$ |
| Velocities | $U = U_d / a_{ref}$ |
| Temperatures | $T = T_d / T_{ref}$ |
| Pressures | $P = P_d / \gamma P_{ref}$ |
| Total energies | $E = E_d / \gamma P_{ref}$ |
| Reynolds number | $Re = \rho_{ref} a_{ref} X_{ref} / \mu_{ref}$ |

4.2 GRIDS

The PARC code requires an ordered set of nodal points that represent the geometric boundaries of a flow problem as well as an appropriate distribution of flow-field points between boundaries. As a minimum, the grid must be constructed and ordered in such a way that the indices can be formally considered as coordinates of a curvilinear coordinate system with nonvanishing Jacobian. (Currently, the Jacobian of the coordinate transformation is required to be strictly positive; thus, the handedness of the physical and computational coordinate systems must be the same). The indices of the grid are taken to be J, K, and L (just J and K in 2-D) so that the coordinates of the J, K, L grid point are $[X(J, K, L), Y(J, K, L), Z(J, K, L)]$. Each index is required to be able to vary over its entire range (e.g., $1 \leq J \leq JMAX$) even if some of the points so specified are not part of the flow field. Care must be taken that the grid coordinates are properly nondimensionalized; that is, the dimensional length that corresponds to a unit length in the grid must be the same dimensional length as was used in calculating the Reynolds number (for inviscid flow this is a moot point, of course). Boundary surfaces (physical and computational) must be composed of a patch work of J-, K-, and/or L-constant surfaces with their edges composed of J-, K-, and/or L-varying lines. However, within this restriction, boundary surfaces can be of arbitrary complexity and located anywhere within the grid as long as at least three grid points separate surfaces forming a flow passage. (This must always be the case; otherwise incorrect solutions will occur.) Finally, best results in terms of accuracy and convergence rates will be obtained if the grid is constructed so that boundary and flow gradients are well resolved, and the grid varies smoothly with minimal skewness. Figure 1 displays these gridding concepts for a simple 2-D configuration.

4.3 BLOCKS

Domain decomposition or grid blocking was incorporated into the PARC code primarily to circumvent high-speed computer memory limitations. Use of the concept of domain decomposition also simplifies grid generation about complex geometries and admits grid-embedding techniques. Grid embedding provides an efficient means for local increases in grid resolution. Communication between grid blocks is accomplished through the overlapping of grids. In the simplest version of domain decomposition, multiple "small" grid blocks are generated from a single "large" grid. The smaller grid blocks are exact subsets of the original grid, and each will fit independently into available high-speed memory. The transfer of solution information between grid blocks is very straight forward in this situation, since the smaller grid blocks can be created so that a two-grid point, or one-grid cell, overlap exist between blocks. The flow variables located at the grid points next to an overlapped boundary are used as the boundary-condition values for the adjoining grid block. Thus, the solution process consists of reading grid-block information into high-speed memory, updating all boundary conditions, performing one flow solution iteration, writing boundary-condition values for

adjoining blocks to low-speed memory, writing out the updated flow solution, and then repeating the process for another grid block.

The PARC code also permits block interfaces that do not possess an exact match of grid points between adjoining grid blocks. The only restriction imposed is that these adjoining grid blocks must overlap by a certain minimum amount. For this type of block-interface, interpolation stencils are created prior to the start of the flow-field iterations. These stencils prescribe how flow-solution values are to be interpolated from the interior grid points of one grid block to the boundary grid points of an adjoining grid block. The intended use of this capability is to permit an ordered local increase (or decrease) in grid densities. Thus, the grid in the overlap region of one block can be formed from the grid points of the adjoining grid blocks by adding n grid points between every existing grid point (or by removing n consecutive grid points from each group of $n + 1$ points). This interface structure simplifies the interpolation stencils and therefore keeps interpolation errors to a minimum. This can be important since the PARC code makes no attempt to ensure that the transfer of information between grid blocks is conservative.

4.3.1 Blocking Algorithm

Execution of the PARC code can be thought of as consisting of three phases, initial setup, flow-field solution iterations, and printout and termination. During the initial setup phase, the user-supplied restart file (See Section 5.3) and NAMELIST parameter file (See Section 5.4) are read, and the necessary initialization is performed. The grid, metrics, Jacobians, boundary-condition information, and block-dependent parameters are written out to different direct-access working files. Each grid block corresponds to one record of the five working files. The grid-block identification numbers and the direct-access file record numbers are assigned according to the order in which the grid-block information appears in the NAMELIST input. Then, for each block, interpolation stencils are created by a search procedure that identifies the grid cells that encompass the boundary points of adjoining grid blocks. After the cells are identified, interpolation weighting factors are written to a direct-access file along with the encompassing cell indices. Each block interface is assigned a unique number by the user (See discussion of INTERJ, INTERK, and INTERL in Section 4.8). This interface identification number corresponds to a single record of this file. Since a block interface joins two blocks, there are two direct-access files used for interpolation stencil storage. One file stores one side of the interface, and the other file stores the other side of the interface. During the course of the iterative flow-field solution process, the interpolation stencils are read and used to calculate block-interface boundary values. These interface flow-field values are stored in two direct-access files in the same manner as the interpolation stencil information.

The flow-field solution proceeds by iterating once on one block at a time. The block order may be specified by the user as follows: Each grid block on the restart file is assigned an integer identifier based on the order in which it is read. That is, the integer 1 is assigned to the first block, and so forth to the last block, which is assigned the integer value of NBLOCK (the user-specified total number of grid blocks). Blocks are processed according to the integer sequence specified by the elements of IBORD, an integer vector with MBORD elements contained in NAMELIST INPUTS (See Section 5.4). This sequence may or may not include all the blocks, and blocks can be repeated as desired. For example, if $IBORD = 3, 1, 2, 1$ ($MBORD = 4$), then the third block read will be processed first, the first block read will be processed second, the second block read will be processed next, and the first block will be treated again before the entire sequence is repeated. Note that use of this technique causes the meaning of the parameter NMAX to change. Instead of specifying the number of flow-field solution iterations, it determines the number of times the block sequence is repeated.

For each block, at the start of each iteration, the grid, metrics, Jacobians, boundary-condition information, block-dependent parameters, and flow-field variables are read from external storage. The block-interface values are also read and used during the boundary update process. The flow-field is updated and then the interpolation stencil is used to calculate the boundary values for adjoining grid blocks. The boundary flow-field properties of adjoining blocks are then written out to external storage. After the updated flow-field variables are written back to external storage, the process starts over with another grid block. Once the iteration process has been completed, user-selected portions of each grid-block flow-field are printed (See Section 4.9), and a new restart file is written.

In essence, the original (unblocked) PARC code has been extended to handle multiple blocks simply by enclosing appropriate portions of the program in FORTRAN DO loops, adding additional routines to perform input and output of the block data, and incorporating block-interface boundary conditions. The basic solution algorithm was not modified except for the method of data array allocation. One of the most awkward aspects of an out-of-memory flow solver is the efficient allocation of high-speed memory. Since grid-block aspect ratios may vary drastically, it is difficult (in FORTRAN) to dimension working arrays so that each grid block can be accommodated efficiently. The best technique using standard FORTRAN 77 is to pass the arrays as subroutine parameters and dynamically dimension them. Unfortunately, this method makes multileveled subroutine calling very complex and difficult to maintain. Similarly, working strictly with one-dimensional arrays, as has often been done in other programs, leads to an extremely difficult program maintenance problem. The approach that has been adopted, reluctantly, is to use nonstandard FORTRAN. CRAY FORTRAN permits the use of pointers for the dynamic allocation of arrays. The pointers to array addresses are determined during the initial setup phase and are included as part of the parameter information for each block.

interpolation stencils use only interior solution values to update boundary points. Otherwise solution convergence rates will be greatly reduced or nonexistent. Two one-dimensional examples are shown in the following that illustrate a correct noncontiguous interface and then an incorrect interface.

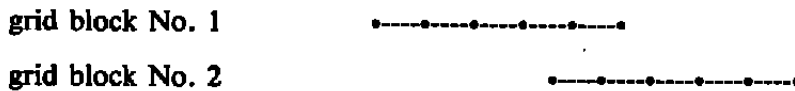

In the above example, both blocks one and two are sufficiently overlapped to allow correct interpolation of boundary points.

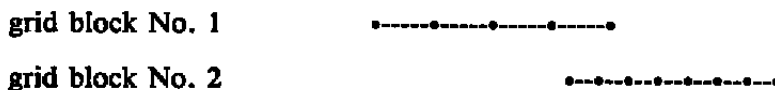

In this case, block one is sufficiently overlapped onto grid-block two, but block two is not sufficiently overlapped onto block one. It is worth noting that the PARC code will run this case without flagging the incorrectness of the grid overlap.

The case of ordered decrease in grid resolution may appear at first to be an incorrect overlap for a noncontiguous interface, but it is actually correct as illustrated in the following one-dimensional example:

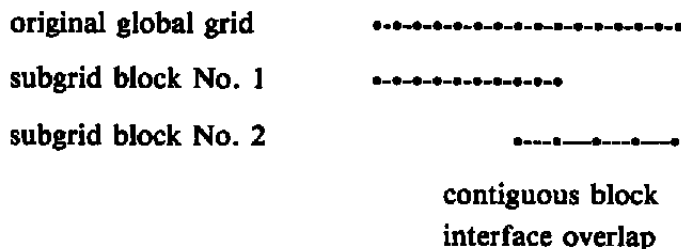

Even though the block one interface boundary point may require the block two boundary point as part of its interpolation stencil, the weighting factor for the interpolation will be zero (i.e., the interpolation reduces to an injection case). The equivalent 2- and 3-D examples would require interpolation for some of the points, but, again, the weighting factors for the boundary points would be zero.

Only two warning messages are printed concerning the correctness of block-interface overlaps. When an interpolation actually becomes an extrapolation over a distance of more than one grid cell, an error message will indicate that the grid point is **DEFAULTED**. This means that the flow-field values at that point will not be changed from their original values (i.e., interpolation will not be performed). The second warning message will indicate that a point will be extrapolated. This is a warning that the blocks are not properly overlapped, so that the flow-field values will be updated using extrapolation. Should either warning message appear, the grid blocks in question should be examined to determine the cause of the improper grid-block overlap. Some cases have occurred where the grid blocks were in fact overlapping, but the warning messages indicated the opposite. This contradiction has always been caused by the interpolation search routine failing as a result of extreme grid skewness, in which case the grid(s) need adjustment.

4.4 INITIAL CONDITIONS

The PARC code is designed so that every application of the code is treated as if a partially converged flow field were available for input; that is, execution of this code always requires a restart file. The restart file, which is described in Section 5.3, must be supplied by the user on the initial run. This means that the user must generate his own grids and initial conditions for the flow-field to be simulated. Although the PARC code has a demonstrated capability to proceed trouble-free from very arbitrary initial conditions, there are some useful general guidelines that can avoid certain convergence problems.

1. If the initial conditions are known to be far from the expected steady-state conditions, it helps to start with the second-order artificial viscosity coefficient (DIS2) set at its maximum value (0.25).
2. Avoid starting with very strong gradients (e.g. orders-of-magnitude differences within a few grid points) in any of the thermodynamic variables.
3. It is generally better to evacuate a region than to fill it. That is, specify pressures that are high compared to some of the boundary pressures rather than ones that are low compared to some of the boundary pressures.
4. Avoid trying to converge large regions of low Mach number flow and high Mach number flow simultaneously.
5. Attempt to generate a good estimate of the expected steady-state conditions, but don't try too hard. In general, only a factor-of-two improvement in the overall convergence rate is observed between poor and very good initial conditions.

4.5 FLOW SOLVERS

The PARC code has been developed in such a way that, although many different types of flows can be treated, only two versions are required. These versions are based on the dimensionality of the flow problem. PARC3D is designed for 3-D flows, and PARC2D is designed for 2-D and axisymmetric problems. The axisymmetric option of PARC2D is selected by setting the input parameter IAXISY to the appropriate value. A value of zero for this parameter selects the 2-D form of the Navier-Stokes equations; the axisymmetric form is selected by a value of one (the default). When interpreting the results from the 2-D version of the PARC code, it is important to keep in mind that they represent a 3-D solution with a special kind of symmetry. For example, the calculated 2-D mass flux is per unit depth (based on reference length used to nondimensionalize the grid), and the calculated axisymmetric mass flux is per radian.

Since the PARC code thermodynamics are based on a nondimensionalized perfect-gas formulation, the only input required to determine the thermodynamic state of the flow is the ratio of specific heats (γ , default value of 1.4). For flows that are not calorically perfect, an "effective" γ must be used. Other thermodynamic properties of the flow (e.g., transport coefficients) are covered in the viscous flow discussion (See Section 4.5.2).

4.5.1 Inviscid Flow

The PARC code may be used to simulate either viscous or inviscid flows. Selection of the inviscid option is made through the input parameter INVISC, an integer vector with either two (2-D) or three (3-D) elements. Each element is paired with a grid index as follows: 1—J, 2—K, 3—L [e.g., INVISC(2) contains information relating to the K-index]. Setting all of the elements of INVISC to zero causes the PARC code to solve the inviscid Euler equations. Several things need to be kept in mind when using the PARC code to simulate inviscid flows. One is that although the grid density and stretching requirements of viscous flow simulation are greatly relaxed for inviscid flow simulations, the grid spacing near boundaries needs to be small enough so that the first-order accurate boundary conditions do not introduce too much error into the solution. The other concerns convergence rates. Since the inviscid equations of fluid dynamics do not have any natural dissipative mechanism, and since the boundaries reflect waves, the best convergence rates are obtained by an artful use of the artificial dissipation. The artificial dissipation coefficients (DIS2 and DIS4, see Section 4.6) should be large to start with (maximum dissipation of spurious transients) and then reduced as much as possible (maximum accuracy). This takes some skill since any change in any flow parameter produces a perturbation in the simulated flow, which takes a number of iterations to relax.

4.5.2 Viscous Flow

Viscous flow simulations are also selected through the INVISC input parameter (See Section 4.5.1). A value of one for an element of INVISC causes viscous flux differences to be included for that coordinate direction [e.g., $\text{INVISC}(2) = 1$ causes the difference between the appropriate viscous fluxes at $K + 1$ and $K - 1$ to be calculated at every grid point]. Several specializations of viscous flow can be specified depending on the values of each element of the integer vector INVISC. A thin-layer simulation (similar to that provided in the ARC code) can be selected by setting the element of INVISC that corresponds to the coordinate that varies across shear layers to one; all other elements of INVISC are set to zero [e.g., in a 2-D problem for which the K -varying lines cross the shear layers, this option is selected by $\text{INVISC}(1) = 0$, $\text{INVISC}(2) = 1$]. Fully viscous simulations are selected by setting all of the elements of INVISC to one (the default). For complex viscous flows, the last option is always recommended.

Viscous flow simulations may be either laminar or turbulent. Laminar flow simulations are selected by setting all of the elements of LAMIN, an integer vector whose elements are connected with the grid indices in the same way as INVISC (See Section 4.5.1) to zero. A value of one for any element of LAMIN causes the flow to be treated as turbulent. For the algebraic turbulence model to produce best results, always set the elements of LAMIN as described for the thin-layer option for INVISC. The algebraic turbulence model provided with the PARC code is based on the assumption that the coordinate direction across shear layers is known, as set by the nonzero element of LAMIN. However, if any element of LAMIN is nonzero, then turbulent shear stresses will be calculated as determined by INVISC. For example, if $\text{INVISC} = 1, 1$, and $\text{LAMIN} = 0, 1$, then the turbulent shear stresses will be calculated assuming that K -varying lines cross shear layers, and these stresses will be calculated for both coordinate directions (fully viscous).

For either laminar or turbulent simulations, several additional parameters must be specified that are not required for inviscid simulations. The Sutherland viscosity law requires the specification of TSUTH and TREFR. TSUTH is the Sutherland viscosity law temperature (frequently denoted as S) appropriate for the fluid being simulated. TREFR is the reference temperature that was used to nondimensionalize the initial flow field and the boundary conditions. Both of these temperatures must be in the same units (e.g., degrees Rankine). Note that TREFR is also used to dimensionalize the printed output (See Section 4.9). Although the default value ($-2/3$, Stokes hypothesis) for the second coefficient of viscosity is usually appropriate, it can be changed through the input parameter VRAT. All viscous flow simulations also require the specification of the Prandtl number (input parameter PR) and the Reynolds number (input parameter RE). The Prandtl number is usually obtainable from tabulated values, but may be calculated directly by the ratio of thermal conductivity to the

specific heat at constant pressure and the first coefficient of viscosity, all at reference condition. On the other hand, the Reynolds number, RE, must be calculated based on the reference density, reference speed of sound, reference length, and reference viscosity.

The algebraic turbulence model included in the PARC code has been optimized for internal flow involving free jets (e.g., rocket exhaust flows in a ground test diffuser). However, it has been successfully used for a wide variety of flow simulations (e.g., turbine engine inlet flows at flight conditions). If the turbulence simulation proves to be inadequate, there are a number of alternatives. The easiest is to vary the values of the adjustable constants in the PARC turbulence model. The parameter COFMIX (default 0.09) scales the turbulent viscosity for free shear layers. For example, if it is determined that a wake is not spreading fast enough, increasing the value of COFMIX from its default value may improve the quality of the simulation. Another adjustable constant, PRT, determines the relative strength of turbulent thermal diffusion to turbulent velocity diffusion. Variation of this parameter from its default is almost entirely an art and is not recommended unless the user is well versed in the subject of turbulence. The last, and not least, way to improve a turbulent simulation using the PARC code is to replace the existing turbulence model with a new one. Although this requires considerable skill, it is a skill which any serious CFD group can not afford to be without. The mechanics of this replacement are straightforward as the PARC code was developed with this possibility in mind. Subroutines MUTUR and MUTURW need to be replaced with new routines which store the values of eddy viscosity in the array TURMU.

4.5.3 Transient Flow

Although the PARC code was primarily designed to simulate steady-state flows, it has been successfully used to solve a number of transient-flow problems. For this purpose, two simulation techniques are selectable through an appropriate setting of the input parameter ISOLVE. A value of one for ISOLVE selects the pentadiagonal solver. This is the steady-state solution algorithm that is the default. This simulation algorithm will always produce the best convergence rates for steady-state flow simulations. It is also the most efficient way to simulate transient flows (large time-step size). However, the pentadiagonal solver does not track shocks or other strong gradients very accurately. If this solution technique is used, the input parameter IVARDT must be set to zero (See Section 4.7). A value of zero or minus one for ISOLVE selects the pseudo-Runge-Kutta solver. Although not normally recommended, a value of zero for ISOLVE selects a local time-stepping version of this solution algorithm (local CFL number set by DTCAP; see Section 4.7). Whereas a value of minus one for ISOLVE provides a time-accurate solution using the pseudo-Runge-Kutta flow solver, the input parameter IRKORD determines the order of the method. A value of three gives a three-stage scheme, a value of four gives a four-stage scheme, and a value of five gives a five-stage scheme. For either of these transient-flow-simulation methods, the time-step size is determined by the value of DTCAP (See Section 4.7).

4.6 ARTIFICIAL VISCOSITY

The degree of artificial viscosity used in a PARC code simulation of fluid flow is primarily determined by the values of the input parameters DIS2 and DIS4. DIS2 is the global scaling factor of the second-order artificial viscosity coefficient. This type of dissipation is very diffusive in general. Its primary purpose is to enhance stability and accuracy in the vicinity of strong shocks and to improve the robustness of the PARC code during strong transients. An automatic damping coefficient limits the effectiveness of this type of dissipation to regions of the flow that possess significant numerical pressure gradients [i.e., where $P(J+1,K,L) - P(J-1,K,L)$ is large compared to $P(J,K,L)$]. Thus, expansions and compressions that are resolved over a small number of points can trigger an inappropriate amount of this artificial viscosity. The only remedies are to reduce the value of DIS2 or, better yet, to regrid for better resolution in these areas. In general, it is recommended that all simulations be started with DIS2 at its maximum value (0.25, the default), and then to reduce the value of DIS2 as low as is consistent with stability and accuracy. This is an exacting art since any change in any flow parameter produces a perturbation in the simulation, which takes further iterations to remove.

DIS4 is the global coefficient of the fourth-order artificial viscosity. This type of dissipation is uniformly applied, but should have no more effect on the accuracy of the solution than that produced by the inherent errors of the PARC algorithm. Although the DIS2 parameter's value can often be set to zero with minimal effect on stability (no strong shocks or expansions), decreasing the value of DIS4 often produces negligible differences in the flow field. Thus, it is generally recommended that the value of DIS4 be kept at its maximum (0.64, the default). After the value of DIS2 has been reduced as much as possible, reduction of the value of DIS4 can be attempted to note its effect on the simulation. However, as noted previously, this is rarely worthwhile.

A number of ways are also provided for modifying the variable part of the artificial viscosity coefficients (the spectral radius term). When simulating viscous flows, it is imperative that the artificial dissipation be less than the corresponding physical dissipation. Setting the input parameter IFILTR equal to two selects a viscous correction to the spectral radius term. This correction sets the spectral radius term to zero wherever the cell Reynolds number is less than two. Since this modification is computationally expensive, the default value for IFILTR should be used unless there is reason to think that the artificial dissipation is swamping the physical dissipation. The input parameter SPLEND determines how the spectral radius term is calculated and, thus, how diffusive the artificial viscosity will be in the simulated flow. A value of one for SPLEND (the default) selects isotropic artificial dissipation. That is, the spectral radius term at each grid point, is based upon an average of the spectral radius terms calculated for each coordinate direction. This option is very stabilizing, but very diffusive.

Setting **SPLEND** to zero provides a nonisotropic artificial dissipation coefficient. The spectral radius, for each coordinate direction, is used as calculated and is not averaged. This minimizes the effect of artificial dissipation, but is not as robust as the first option, especially during the initial transient phase of a simulation. A compromise between these two extremes may be selected by setting **SPLEND** to a value between zero and one, which gives a nonlinear weighted average of the isotropic and nonisotropic approaches.

Finally, if the pseudo-Runge-Kutta solver (See Section 4.5) has been selected, a means has been provided to allow for larger time steps (CFL numbers) at the price of reduced temporal accuracy. Setting the input parameter **SMOO** to one activates the implicit residual smoothing option. This option averages the forcing functions (the RHS) before each pseudo-Runge-Kutta step. Care must be used with this option since the time accuracy of the solution may be degraded to the level of that provided by the pentadiagonal solver, without a corresponding increase in the time-step size.

4.7 TIME-STEP CONTROL

Since the time-step size has a direct effect on the convergence rate, quite a bit of flexibility is built into the **PARC** code in terms of time-step control. Most basic is the ability to set the number of iterations to be performed and current iteration number. The maximum number of iterations to be performed during the current execution of the **PARC** program is set through the input parameter **NMAX**. For example, if **NMAX** = 1,000 were input in a simulation for which the restart file contained the solution at a total iteration count of 2,000, then 1,000 iterations would be performed during execution of the **PARC** code, and the total iteration count of the resulting restart file would be 3,000. The value of **NMAX** is ignored if the parameter **NUMDT** is nonzero (See the following). The initial value of the total iteration count can be changed from that on the input restart file (See Section 5.3) by appropriate use of the input parameter **NC**. If the value of **NC** is minus one (the default value), then the iteration count on the restart file is used, otherwise the value of **NC** is used. For example, if the value of **NC** is zero, the value of **NMAX** is 1,000, and the value of the iteration count on the input restart file is 2,000, then the value of the iteration count on the output restart file will be 1,000.

Two other ways of specifying when the execution of the **PARC** code should stop, with normal printed and restart output, are also provided. A nonzero value of the input parameter **STOPL2** specifies the L_2 residual level at which the current execution of the **PARC** code is to be terminated. This option must be used with care since the L_2 residual is a relative measure of convergence and not an absolute one. Note that the value of the parameter **NSPRT** must be a relatively small factor of the value of **NMAX** for this option to be effective. A nonzero value of the input parameter **STOPTR** specifies that, after each iteration for each

block, the PARC code checks the time remaining for the computer job. When the time remaining (in seconds) is less than the value of STOPTR, the program terminates. It is sometimes convenient to set NMAX to a large value and let the solution continue until it runs out of time. Care must be taken to set STOPTR large enough that the program has time to write and dispose all of the requested output files.

Also of considerable importance is the ability to directly set the iteration step size. DTCAP is the input parameter that sets the maximum time-step size allowed during a run. However, its exact use depends on the values of other input parameters. In particular, the value of DTCAP is ignored if the value of either NUMDT or DTBLK is nonzero (See the following sections). The value of the input parameter IVARDT controls the use of DTCAP. If IVARDT is set to zero, then this is the nondimensional computational time step. (The simulation is time accurate.) Other values of IVARDT cause the value given by DTCAP to be scaled by local (grid point location dependent) parameters that are designed to accelerate steady-state convergence. If IVARDT is set to one, then the local time step is proportional to the reciprocal of one plus the square root of the Jacobian. If IVARDT is two, then the local time step is proportional to the reciprocal of the maximum eigenvalue of the inviscid flux Jacobians including a viscous correction, if required. This last option can be viewed as selecting a local time step such that the local Courant numbers are roughly equal (to the value of DTCAP). This has proved to be the best choice, in general, for accelerated convergence rates. However, this option can sometimes produce very poor convergence rates. If this should appear to occur, try one of the other options. For the Runge-Kutta solver (See Section 4.5), IVARDT is ignored, and the value of DTCAP provides either a true time-step size or a limiting CFL value (2.8 or 8.4 with implicit residual smoothing).

4.7.1 Temporal Variation

This option (selected by setting IVARDT to one or two) allows the global time-step size (DTCAP) to automatically vary from iteration to iteration. This is useful for two purposes.

1. **Stability** — This option can detect potential stability problems caused by the time-step size being too large and, the option will automatically attempt to correct this condition by reducing the global time-step size.
2. **Convergence** — This option can force the solution to proceed at a rate determined from the maximum relative change in density or pressure in the flow field.

The parameters controlling this option are PCQMAX and DTCAP (or DTBLK; see the following). PCQMAX is an input parameter whose value determines the maximum percent change in either density or pressure to be allowed during any iteration. Recommended range

for this parameter is between 1 and 25. Best use of this temporally varying time-step option is to set the values of these parameters appropriately for the degree of convergence.

1. **Initial Stage** — During the first set of iterations, until the solution begins to resemble its steady-state configuration, it is best to set the value of DTCAP high (say 100.0) and let the value of PCQMAX govern the time-step size (say PCQMAX = 10.0, the default). This will usually get the simulation through the relatively nonphysical, rapidly changing part of the convergence process in the fewest number of iterations.
2. **Asymptotic Stage** — From the end of the initial stage of convergence until final convergence, it is essential to set the value of DTCAP to a value somewhat lower than the largest value at which the time-step size remains constant throughout a set of iterations (See the convergence statistics discussion in Section 4.9). If this is not done, then final convergence is *impossible* since the solution must then always have at least one point that varies according to the value of PCQMAX.

4.7.2 Time-Step Sequencing

This option allows the user to specify a sequence of time steps (actually values of DTCAP) for use during an execution of the PARC code. Selection and control of this option is affected by the NUMDT, DTSEQ, and ITERDT input parameters. NUMDT is a time-step sequencing selection parameter. A value of zero (the default) does nothing (no time-step sequencing), whereas a positive value both selects this option and provides the number of sequencing steps. Selection of this option requires the presence of the NAMELIST SEQDT as described in Section 5.4. If NUMDT is nonzero, then it sets the number of time sequencing steps (limited by MOS, see Section 5.1) and NAMELIST SEQDT must follow INPUTS. SEQDT has only two parameters, described as follows:

- | | |
|---------------|--|
| DTSEQ | A real vector that contains the sequence of DTCAPs to be used during the run. |
| ITERDT | An integer vector containing the sequence of iteration limits (similar in effect to NMAX for each time step) to be used during the run. These are paired up one-to-one with the elements of DTSEQ. |

Although theory and experience show that an optimal sequence of time steps can dramatically speed up convergence rates, there is little guidance on how to *a priori* determine this sequence. Nonoptimal sequences can actually worsen the convergence rate, so it is best to treat this option with care.

4.7.3 Block Variation

A different value of DTCAP can be specified for each grid block through the input parameters DTBLK. This parameter is only effective if more than one grid block is being used. If DTBLK is greater than zero, this value is used as the DTCAP for the block, overriding the global DTCAP. If not greater than zero, the global DTCAP is in effect (i.e. either DTCAP or the appropriate element of DTSEQ in effect).

4.8 BOUNDARY CONDITIONS

The PARC code is designed so that specification of boundaries and boundary conditions is done entirely through inputs to the program. This makes the use of the code very flexible and economical, but requires that boundary specification be a large part of the inputs. As an aid in explaining the function of the boundary parameters, the simple problem laid out in Fig. 2 will be used as an example application. Refer to Appendix E for more realistic applications.

4.8.1 Construction Procedure

The methodology to be used in generating the information required to specify the boundary parameters is as follows:

1. Locate and label boundary segments; break the boundaries up into segments so that each segment is
 - a. contained on a coordinate surface (J-, K-, or L-constant surface);
 - b. made up of contiguous points that can use the same boundary-condition information (e.g., each point is a no-slip wall point with the same specified temperature);
 - c. simply connected (i.e. no "holes" or excluded points); and
 - d. "wetted" by the fluid within the grid on one, and only one, side.
2. The resulting boundary segments are considered to belong to one of the J-, K-, or L-constant index classes and are then numbered in any convenient manner, starting with 1, within each index class. (This numbering is not required if the formatted read option is used.) As illustrated in Fig. 2, the example problem's boundaries are split into five segments with two in the J-constant class and three in the K-constant class and have been appropriately numbered.

3. Determine the indices of each segment. This is generally an automatic by-product of the first step.
4. Find the sign of the surface normal for each segment; this is determined by using the index increment required to move from the constant index surface of the segment to the similar constant index surface within the flow field. For example, consider the case of a segment in a K-constant surface. If the K-1 constant surface (bounded by the same J and L limits as the K-constant segment) is within the flow field, then the unit normal is -1. (Note that if this procedure results in an ambiguous unit normal, then the segment has been incorrectly specified).
5. Determine the desired boundary-condition code and any auxiliary variables. Each boundary condition allowed for in the PARC code has a boundary-condition-type code assigned to it. Some of these also require auxiliary information (e.g., static pressure). The boundary-condition types and auxiliary variables are listed in the following table:

Boundary-Condition Types

| <u>Code</u> | <u>Description</u> | <u>Auxiliary Variables</u> |
|-------------|---------------------|----------------------------|
| - 10 | Fixed | None |
| 0 | Free | PRESS and TEMP |
| 3 | Extrapolation | None |
| 7 | Free Stream | PRESS and TEMP |
| 50 | Slip | None |
| 51 | Axis-of-Symmetry | None |
| 60 | No-Slip, Adiabatic | None |
| 61 | No-Slip, Isothermal | TEMP |
| 70 | Contiguous | INTER |
| 71 | Noncontiguous | INTER |
| 73 | Void | INTER |
| 77 | Continuous Pressure | INTER |
| 80 | Averaging (2-D) | None |
| 81 to 83 | Averaging (3-D) | None |
| 91 to 96 | Specified Mass Flux | PRESS and TEMP |

A detailed description of each boundary condition follows:

Fixed Conditions All flow-field values are held fixed at their initial values provided by the restart file. Suggested use is for known supersonic inflow boundary segments.

Free Boundary The auxiliary pressure and temperature are assumed to be total values on inflow portions of the boundary, and static values on outflow sections. Any boundary segment through which the fluid flow can freely pass and is not a known supersonic inflow (See Fixed Conditions), a known supersonic outflow (See Extrapolation), a far-field external flow (See Free Stream), or a mass flux (See Specified Mass Flux) boundary is considered to be a free boundary. Imposition of the correct inflow or outflow, supersonic or subsonic boundary condition is taken care of automatically. However, the current implementation requires that the user be careful about a couple of points. One is that this boundary condition works best if the boundary segment is close to being normal to the expected flow directions as possible. In particular, boundaries of this type that are nearly parallel to the dominant flow direction almost always produce poor results. The second point to be careful about is caused by the dual use of the specified pressure auxiliary variable. It is used as a total pressure for subsonic inflow and as a static pressure for subsonic outflow, which does not always produce expected results, especially for external flows. The recommended procedure to avoid this problem is to place these boundaries so that the expected dominant flow through them will be unambiguously inflow or outflow and to specify the pressure auxiliary variable accordingly (total or static, respectively), or to use the free-stream boundary condition described below. Note that the total temperature auxiliary variable should always be specified, even if it's only a guess, to avoid possible problems during the large transients portion of the convergence process.

Extrapolation This boundary condition extrapolates all flow-field variables using a zero derivative condition. That is, boundary flow variables are set equal to the values one grid point off of this boundary.

- Free Stream** This is an external far-field boundary condition. Imposition of the correct inflow or outflow, supersonic or subsonic boundary condition is taken care of automatically. The auxiliary pressure and temperature are assumed to be the free-stream static values. No check is made to insure that these values are consistent for different boundary segments. The angle of attack, yaw, and Mach number of the free stream are taken to be ALPHA, BETA, and XMACH (See Appendix A).
- Slip Surface** All flow gradients normal to this boundary segment's surface are taken to be zero along with the component of velocity normal to this surface. This boundary condition does double duty as a symmetry plane boundary condition as well as the slip-wall boundary condition.
- Axis of Symmetry** Very similar in function to the slip-surface boundary condition, this boundary specification is specialized for application to the axis of symmetry for simulations using the axisymmetric option of the PARC2D code.
- Adiabatic wall** All velocity components and the normal gradients of pressure and temperature are set to zero on boundary segments using this option. The current implementation requires that the grid lines intersecting this surface be nearly normal to it for best results.
- Isothermal Wall** Similar to the boundary condition discussed above except that the surface temperature is set to that provided through the temperature auxiliary variable.
- Contiguous** These boundary segments must come in pairs as determined by the auxiliary variable INTER. For the purpose of illustration, call the given boundary segment BC1 and its associated boundary segment BC2. Using the sign of the surface normal for BC2, determine the first constant-index surface inside the flow field next to BC2. It is assumed that BC1 is coincident with this surface. The boundary condition is imposed by setting the flow variables at each node of BC1 equal to the flow variables of its corresponding node.

- Noncontiguous** These boundary segments must come in pairs as determined by the auxiliary variable INTER. To impose the boundary condition, first the block of its associated boundary segment is found; for short call it BJ. For each node of the given boundary segment, if it is located in BJ, then the values of the flow variables at the node are found by interpolation. If it is not located in BJ, then the values of the flow variables at the node are left unchanged.
- Void** Sometimes it is desired to set boundary conditions by interpolation (Type 71) when there is no associated boundary segment in the block from which the interpolations are to be made. In such a case, a boundary segment of Type 73 can be specified in the block where the interpolations are to be made. No boundary conditions are imposed for such a boundary segment. It only indicates the target block for its associated boundary segment. The only information that needs to be input for such a boundary segment is its type (73) and the auxiliary variable INTER.
- Pressure** This boundary condition is identical to Type 71, except between blocks with different GAMMA. The pressure is kept continuous between such blocks. (However, there is an energy discrepancy.)
- Averaging (2-D)** This boundary condition is used when a boundary line (call it B) is degenerate to a point. For each flow variable, the average of the variable is found over all the nodes of B, then the flow variable is set to that average value at all the nodes of B.
- Averaging (3-D)** This boundary condition is used when a boundary surface is degenerate to a line. On such a surface, one set of coordinate lines coincide with the degenerate line, and the other set of coordinate lines are degenerate to points. The boundary conditions are imposed on each of the degenerate coordinate lines as described in the 2-D case above. The last digit of the type code indicates the index that when varied produces the coordinate lines that are degenerate to points.
- Mass Flux** The signed mass flux is specified through the auxiliary pressure. The auxiliary temperature inputs the total temperature of the

flow. This boundary condition functions very similarly to the free-boundary condition except that the pressure is determined indirectly through the specified mass flux. The last digit of the code for this boundary condition (1 through 6) is used to control the relaxation of the pressure towards the value that will produce the desired mass flux, with 1 giving the fastest and 6 the slowest relaxation. The mass flux specified through the auxiliary pressure is to be positive for flow into the flow field and negative for flow out of the flow field.

4.8.2 NAMELIST Input

Once the boundaries are split into segments and the appropriate boundary-condition information is determined for each segment, as described previously, the method of inputting this information to the PARC code must be decided. This method is signaled through the input parameter NBCSEG. If NBCSEG has a value of zero, then this information is input to the PARC code through parameters in NAMELIST BOUNDS. The basic philosophy behind the use of these parameters is very similar to that used in assembling the boundary-condition information in that a set of parameter vectors are associated with each J-, K-, and L- constant index class of boundary segments with the elements of the vectors corresponding to particular segments within each class. This will be made clearer through the description of these parameters and the following example:

| | |
|--------------|--|
| NJSEG | This parameter gives the total number of boundary segments for each of the J, K, and L coordinate classes. |
| NKSEG | |
| NLSEG | |
| JLINE | Integer vectors that identify the J-, K-, and L-constant index of each of the corresponding boundary segments within each coordinate class. |
| KLINE | |
| LLINE | |
| JTYPE | Integer vectors whose elements contain the appropriate boundary-condition-type code for each boundary segment. |
| KTYPE | |
| LTYPE | |
| JSIGN | Integer vectors that associate the sign of the surface normal with the corresponding boundary segment of each of the J, K, and L coordinate classes. |
| KSIGN | |
| LSIGN | |

INTERJ Integer vectors that pair the Types 70, 71, INTERK 73, and 77 boundary segments. Each pair of associated boundary segments must be assigned a unique number from 1 to MXIF (See Section 5.1).
INTERK
INTERL

PRESSJ Vectors of auxiliary pressures for each coordinate class. Depending on the type, the definition is as follows:
PRESSK
PRESSL

| Type | Definition |
|-------------|---|
| 0 | Nondimensional total pressure for subsonic inflow. Nondimensional static pressure for subsonic outflow. |
| 7 | Nondimensional static pressure of the free stream. |
| 91 to 96 | The nondimensional signed specified mass flux. |

TEMPJ Vectors of auxiliary temperatures for each coordinate class. Depending on the type, the definition is as follows:
TEMPK
TEMPL

| Type | Definition |
|-------------|---|
| 0 | Nondimensional total temperature for subsonic inflow. |
| 7 | Nondimensional static temperature of the free stream. |
| 61 | Nondimensional temperature of the isothermal wall. |
| 91 to 96 | Nondimensional total temperature for inflow. |

The following integer parameter vectors associate the appropriate coordinate indices with each boundary segment. This association is coded into the parameter vectors name so that the first letter calls out the J-, K-, or L- constant index class; the second letter identifies the coordinate index being specified; and the remaining letters indicate whether this is the minimum (LOW) or maximum (HIGH) value of this index for the boundary segment. For example, JKLOW(2) = 15, is interpreted to mean that the minimum value of the K-index for the second boundary segment in the J-constant segment class is fifteen. The complete set of parameter vectors for this purpose are

| | | | |
|-------|--------|-------|--------|
| JKLOW | JKHIGH | JLLOW | JLHIGH |
| KJLOW | KJHIGH | KLLOW | KLHIGH |
| LJLOW | LJHIGH | LKLOW | LKHIGH |

Consider the example problem shown in Fig. 2. A complete NAMELIST BOUNDS setup could look like

```

$BOUNDS
  NJSEG = 2,
    JLINE(1) = 1, JKLOW(1) = 1, JKHIGH(1) = 7, JTYPE(1) = -10,
      JSIGN(1) = 1,
    JLINE(2) = 9, JKLOW(2) = 2, JKHIGH(2) = 6, JTYPE(2) = 0, JSIGN(2) = -1,
      PRESSJ(2) = 0.0047, TEMPJ(2) = 1.0,

  NKSEG = 3,
    KLINE(1) = 1, KJLOW(1) = 2, KJHIGH(1) = 2, KTYPE(1) = 50,
      KSIGN(1) = 1,
    KLINE(2) = 1, KJLOW(2) = 3, KJHIGH(2) = 9,
      KTYPE(2) = 61, KSIGN(2) = 1, TEMPK(2) = 0.5,

    KLINE(3) = 7, KJLOW(3) = 2, KJHIGH(3) = 9, KTYPE(3) = -10,
      KSIGN(3) = -1,

$SEND

```

Additional examples of boundary-condition specification through this NAMELIST are contained in Appendix E.

4.8.3 Formatted Input

An option is provided whereby boundary-condition data can be input by a formatted read rather than by NAMELIST BOUNDS. The option is invoked by a nonzero value of NBCSEG. The value of NBCSEG must be the total number of boundary segments of all classes. The formatted data is read by the following FORTRAN READ and FORMAT statements:

2-D

```

  READ (5,101) JA,JB,KA,KB,ITYPE,ISIGN,INTER,PT,TT
101 FORMAT (7I5, 5X, 2E10.4)

```

3-D

```

  READ (5,101) JA,JB,KA,KB,LA,LB,ITYPE,ISIGN,INTER,PT,TT
101 FORMAT (9I5, 5X, 2E10.4)

```

where

| | |
|-------------------|---|
| JA, KA, LA | Minimum J-, K-, and L-grid indices of the boundary segment. |
| JB, KB, LB | Maximum grid indices of the boundary segment. Note that the minimum and maximum index will be the same for the constant coordinate index. |
| ITYPE | Type of boundary condition (See Boundary-Condition Types in the previous table). |
| ISIGN | Sign of the surface normal of the boundary segment. |
| INTER | Unique number assigned to each pair of associated boundary segments. |
| PT | Auxiliary pressure. |
| TT | Auxiliary temperature. |

Considering again the example problem shown in Fig. 2, the formatted data is given in the following. (The two lines at the top indicate the column positions and are not part of the input data.). The boundary segments can be input in arbitrary order.

| | | | | | | |
|---|------------|------------|------------|------------|------------|------------|
| | 1 | 2 | 3 | 4 | 5 | 6 |
| | 1234567890 | 1234567890 | 1234567890 | 1234567890 | 1234567890 | 1234567890 |
| 1 | 1 | 1 | 7 | -10 | 1 | |
| 1 | 1 | 1 | 7 | -10 | 1 | |
| 2 | 9 | 7 | 7 | -10 | -1 | |
| 3 | 9 | 1 | 1 | 61 | 1 | 0.5 |
| 9 | 9 | 2 | 6 | 0 | -1 | 0.0047 1.0 |
| 2 | 2 | 1 | 1 | 50 | 1 | |

4.9 OUTPUT

Printed output consists of four parts,

1. a record of the run parameters;
2. various error messages;
3. convergence statistics generated as the run progresses; and
4. an edited printout of the solution.

4.9.1 NAMELIST Parameters

The first part of the printed output written to Unit 6 (FT06) is a listing of the values of the NAMELIST input parameters that were used during the current execution of the PARC code. They are printed in groups corresponding to the individual NAMELISTs. Each group of parameters appears only if the NAMELIST containing them was part of the actual input on Unit 5 (FT05) (See Section 5.1). Sample listings showing this output are included in Appendix E. Note that these tabulated values are not simple echoes of the input values since they are not printed immediately after they are read and in that they include default values; users wishing a true echo of their NAMELIST input should use the E prefix on their NAMELIST records (See the CRAY FORTRAN manual for details).

4.9.2 Grid Patches

To facilitate the treatment of embedded boundaries within a grid, the grid is always broken down into a set of patches for each of the computational coordinate directions (J, K, and L). These patches are automatically constructed from the boundary inputs (See Section 4.8 and Appendix C) and are, thus, normally of no concern to the user. If boundaries are misspecified, however, incorrect patches will result. Information about the patches can then be of aid in identifying the boundary specification problem. Because the major problem in the provision of proper inputs to the PARC code is often connected to boundary specification, especially for complex 3-D simulations, a summary of the grid patches is provided as part of the printable output.

Grid patches are generated so that for each coordinate family of patches

1. each patch is distinct from all other patches in the same family;
2. every flow-field point and only flow-field points are included in the family of patches, excluding boundary points; and
3. each coordinate line along which the patch family descriptor varies begins and ends one point off of a boundary.

For example, consider Fig. 3, which displays the patches that would be generated for a hypothetical fluid flow problem. The grid for this example is plotted in computational coordinates (J, K) in Fig. 3a, and the J- and K-patches are cross-hatched in Figs. 3b and c, respectively. Note how the cross-hatched regions obey the above guidelines for both the J and K families of patches. The printed output for this example would appear as follows:

GRID PATCHES

| J-PATCHES | MINIMUM | | MAXIMUM | |
|-----------|---------|---|---------|---|
| | J | K | J | K |
| 1 | 5 | 2 | 15 | 3 |
| 2 | 2 | 4 | 15 | 5 |
| 3 | 2 | 6 | 9 | 8 |
| 4 | 12 | 6 | 15 | 8 |

| K-PATCHES | MINIMUM | | MAXIMUM | |
|-----------|---------|---|---------|---|
| | J | K | J | K |
| 1 | 2 | 4 | 4 | 8 |
| 2 | 5 | 2 | 9 | 8 |
| 3 | 10 | 2 | 11 | 6 |
| 4 | 12 | 2 | 15 | 8 |

Note that the patches are delimited by giving the coordinates of the corner points of each patch (actually just the maximum and minimum ones). When errors in boundary specification occur, the information contained in the error message, along with the grid patch tabulation, will often pinpoint the source of the error.

4.9.3 Convergence History

The next portion of the printed output contains information on the convergence behavior of the flow simulation. This consists of a line of output at the frequency selected by the input

parameter NSPRT. For example, if the value of NSPRT is ten (the default), then the convergence history parameters (e.g., the L_2 residual) are calculated and printed every tenth iteration. Each line always includes the iteration number (COUNT), grid-block number (BLOCK), time-step scaling factor (DT), L_2 residual, and the magnitude and location of the maximum percentage change in either density or pressure (MAX PERCENT VARIATION). In addition, if selected by the input parameter IFXPRT, this line of output will include a measure of the global conservation of mass, momentum, and energy (the net FLUXes). A value of zero (default) for IFXPRT excludes the flux balances from the printed convergence history, and a value of one causes the flux balances to be calculated and printed. See Appendix E for sample printouts showing the format of this part of the printable output. This convergence history listing contains the information required to set DTCAP and gives an indication of the overall level of convergence of the solution. As noted previously, the L_2 residual is a relative measure of convergence; it is best to monitor the fluxes for a more absolute measure of convergence.

4.9.4 Flow-Field Snapshot

The last part of the printable output contains a listing of selected portions of the flow field at the frequency selected by the input parameter NP. A value of zero (default) for NP suppresses flow-field print. A positive value is used as the frequency for printing snapshots of the flow field (See the discussion of the parameter NSPRT for an example). Each line of this listing contains the grid index, the dimensional pressure, temperature, Mach number, total pressure, direction cosines of the velocity, and the nondimensional physical coordinates of each grid point selected. The pressures and temperatures are dimensionalized by the values of the input parameters PREF and TREFR, respectively. Velocity vector direction cosines are the same as the ratios of the velocity components to the magnitude of the velocity (e.g., V-COSINE is the ratio between the component of velocity parallel to the Y-axis and the magnitude of the velocity at the selected point). See Appendix E for sample listings containing this information.

To reduce the amount of printed output while providing information on regions of interest within the flow field, a set of options are available that allows control over the range, increment, and order of the printed flow-field points. If the input parameter NPSEG is set to zero, then nothing is printed for the block, and NAMELIST PRTSEG should not appear in the input stream. If NPSEG is positive, then NAMELIST PRTSEG should appear, and the following should be defined:

NPSEG The number of flow-field segments specified in NAMELIST PRTSEG. PRTSEG must appear in the input as indicated in Section 5.4, if NPSEG is positive.

JKLPI An integer array dimensioned (3, 3, MPS) for PARC3D and (3, 2, MPS) for PARC2D. The values contained in this array specify the coordinate limits and print increments for each segment called for by the value of NPSEG. Referring to Fig. 4, it can be seen that this array contains the indices of diagonally opposite corner points of the segment to be printed. It also contains the desired increments to be used in stepping the indices from the starting point (Point A) to the ending point (Point B). For this to produce correct results, the statement $(JB - JA)/JI \geq 1$ must be true, as for the other indices.

IPOED An integer array dimensioned (2, MPS) for PARC3D or an integer vector dimensioned (MPS) for PARC2D. This parameter determines the order in which the indices are used in printing each segment (the path used to get from A to B in Fig. 4). Associating 1 with J, 2 with K, and 3 with L, the value of the elements of IPOED indicate which index is to be incremented the fastest. For example, IPOED = 3, 1 in a 3-D problem indicates that the current segment is to be printed with the L-index incrementing the fastest, the J-index the next fastest, and the K-index the least fastest (by implication). See Appendix E for more information on segmented printing.

4.9.5 Error Messages

A variety of program-generated error messages can occur at any point in the printed output, most of them indicating that execution is being terminated. It is always best to examine both the NAMELIST values portion of the listing and the very end of the printable output for error messages even if the run appeared to terminate normally. Most of the errors checked for will occur during run initiation. Those that happen in the course of program execution will cause the program to attempt to terminate with a normal printout and restart file. A special Error Messages Appendix (See Appendix C) is included with this manual to facilitate resolution of program-detected problems.

4.9.6 Plotable Output

Convergence information to be plotted by an auxiliary plot program is also part of the available output from the PARC code. If selected by the L2PLOT and/or the IFXPLT input parameters, a convergence history file, which is suitable for plotting, is created on Unit 21 (FT21). The value of the parameter IFXPLT determines whether flux balance histories are calculated and written each iteration. A value of one activates this option, whereas a value of zero (default) deactivates it. The value of the L2PLOT parameter determines whether L₂

residual histories are calculated and written each iteration. As with the IFXPLT parameter, a value of zero (the default) deactivates it. All information in this file is written unformatted. The first record is always a plot type that determines the contents of each subsequent record as follows:

| CODE | RECORD CONTENTS |
|------|---|
| 1 | N, MB, ΔQ , R_1 , R_2 , R_3 , R_4 , R_5 , R_6 |
| 2 | N, MB, ΔQ , F_1 , F_2 , F_3 , F_4 , F_5 |
| 3 | N, MB, ΔQ , R_1 , R_2 , R_3 , R_4 , R_5 , R_6 , F_1 , F_2 , F_3 , F_4 , F_5 |

where N is the iteration number, MB is the block number, ΔQ is the maximum percentage change in either density or pressure, $R_1 \dots R_5$ ($R_1 \dots R_4$, for 2-D) are the L_2 residuals for each of the conservation equations (density, momentum, energy) and R_6 (R_5 for 2-D) is the total L_2 residual; and $F_1 \dots F_5$ ($F_1 \dots F_4$, for 2-D) are the global conservation fluxes. One record is created for each iteration so that the total number of records in the file will be the total number of iterations requested plus one. Note that use of this option can be very expensive computationally since the L_2 residuals and/or conservation fluxes must be calculated and written every iteration. It is recommended that this option only be used when there is good cause for it (e.g., presentation of results or questions about the actual convergence history).

Two data files used by PLOT3D, a NASA Ames interactive postprocessing program, are written to Units 30 and 31 if input parameter IPLOT has a value of one. The PLOT3D grid input file is on Unit 31, and the flow-field input file is on Unit 30. The data files are written using unformatted writes and are in PLOT3D multiblock format.

5.0 OPERATION

This section is intended to give a brief overview of the major steps involved in setting up and running the PARC code. Details on the PARC code input parameters and related background information are contained in the section on Usage Concepts.

5.1 PARAMETER STATEMENTS

Although every effort has been made to avoid requiring the PARC code user to routinely modify the program itself, there is one area in which this is unavoidable. Since standard FORTRAN will not allow dynamic storage allocation, the user must specify the necessary storage requirements through modifications to certain FORTRAN PARAMETER statements. One must remember that a copy of almost every such PARAMETER statement appears in almost every SUBROUTINE. The following PARAMETER statements appear in the PARC code:

PARAMETER (MEMORY = 1750000)
PARAMETER (NIP = 3800, NM = NIP/5)

with the following parameter definitions:

- MEMORY** The maximum number of high-speed memory words available for use by the PARC code. It should be adjusted so that the PARC code nearly fills the memory available to run your jobs. Ordinarily, the PARC code uses 27 arrays (32 when the Runge-Kutta solver is used with PARC3D). The maximum number of grid points is roughly (MEMORY - 150,000 - 12 NIP) divided by 27 (or 32). When dividing a domain into blocks, all blocks must meet this size limitation.
- NIP** The maximum number of nodes on any face of any block. For PARC3D a "face" is a boundary surface; for PARC2D a "face" is a boundary curve.
- NM** The maximum number of nodes on any edge of any block (ignored in PARC2D as this is the same as NIP). Its value of NIP/5 need never be changed, unless squeezing in a few more grid points is critical.

The PARC code also has the following PARAMETER statements, which rarely need to be changed from their preset values:

PARAMETER (MOS = 100)
PARAMETER (MPS = 10, MBC = 25, MP = 50)
PARAMETER (MXNB = 99, MXIF = 500)

with the following parameter definitions:

- MOS** The limit to MBORD (Section 4.3) and NUMDT (Section 4.7).
- MPS** The limit to NPSEG (Section 4.9).
- MBC** The limit to NJSEG, NKSEG, and NLSEG (Section 4.8).
- MP** The limit to the number of patches (Section 4.9).

- MXNB** The limit to number of blocks, NBLOCK (Section 4.3).
- MXIF** The maximum block-interface identification number (Sections 4.3 and 4.8).

5.2 FILE USAGE

The submit file, batch job file, or job control file (whichever is preferred) must make available (fetch) appropriate input files, compile, load, and execute the source code (PARC2D or PARC3D), and store (dispose) the appropriate output files. This file (the submit file) is not provided as part of the code and must be created by the user. There are three mandatory input files, one of which is the source code, which must always be present at the start of the run,

1. source code (either PARC2D or PARC3D);
2. restart file (assumed to be assigned to Unit 2), which contains the grid and current solution; and
3. parameter file (assumed to be assigned to Unit 5), which contains information necessary to
 - a. specify completely the problem being solved,
 - b. control program execution, and
 - c. select desired input and output options.

Two output files are always created and three, optional, output files can be produced if called for in the inputs. These files are

1. the new restart file (assigned to Unit 4), which contains the grid and the just-calculated solution;
2. the run history file (assigned to Unit 6), which contains a listing of parameter inputs, convergence information, a printed map of selected portions of the flow field, and diagnostic information;
3. residual and/or flux histories file (assigned to Unit 21) intended for plotting. This file is optional as determined by the parameter, IFXPLT, in NAMELIST INPUTS (See Section 4.9); and

4. PLOT3D grid input file (assigned to Unit 31) and PLOT3D flow-field input file (Unit 30). These files are optional as determined by the parameter IPLOT in NAMELIST INPUTS (See Section 4.9).

5.3 RESTART FILE

Two input data files are required to execute the PARC code. One, which is always expected to be on logical Unit 2 (FT02), is the restart file. It was either created by a prior run of the PARC program or assembled by the user's initial condition and grid programs. The file is read by the PARC code using unformatted reads. The first record contains

(Record 1) NC1, GAMMA

where NC1 is the iteration count associated with the particular restart file; GAMMA is the ratio of specific heats (not used by the PARC code, but by supporting postprocessing computer codes). The remaining records are required for each grid block. The second record contains the index dimensions of the first block.

(Record 2) JMAX, KMAX, LMAX

The third record contains the grid coordinates for the first block in arrays X, Y, and Z. The arrays are dimensioned by (JMAX, KMAX, LMAX). These arrays are written in standard FORTRAN order (column order).

(Record 3) X, Y, Z

The fourth record contains the nondimensional flow field for the first block in arrays R, RU, RV, RW, and E, which are the nondimensional density, X-momentum, Y-momentum, Z-momentum, and total energy per unit volume, respectively. These arrays are also dimensioned by (JMAX, KMAX, LMAX).

(Record 4) R, RU, RV, RW, E

Records two through four are repeated as a set once for each grid block. The variable, LMAX, and the arrays, Z and RW, are omitted from restart files for the 2-D PARC code.

5.4 PARAMETER FILE

The other file, which is always expected to be on logical Unit 5 (FT05), is the parameter file. It provides parameter input to the code consisting mainly of NAMELISTs. They must be in the following order:

| | |
|---------------|--|
| INPUTS | Appears always. |
| SEQDT | Appears only if NUMDT is positive (See Section 4.7). |
| BLOCK | Appears always. |
| PRTSEG | Appears only if NPSEG is positive (See Section 4.9). |
| BOUNDS | Appears only if NBCSEG is equal to zero (See Section 4.8). |

If NAMELIST BOUNDS does not appear, then boundary-condition data must appear as formatted data in the same location (See Section 4.8). NAMELISTs BLOCK, PRTSEG, and BOUNDS (or equivalent formatted data) are repeated in order, once for each grid block.

5.4.1 NAMELIST INPUTS

The following lists the variables in NAMELIST INPUTS and their default values. Note that the variable IAXISY is not in the 3-D PARC code, and the variable BETA is not in the 2-D PARC code.

| | | | | | |
|--------|---|----------------|--------|---|--------|
| PREF | = | 0.147000E+02 | IAXISY | = | 1 |
| TREFR | = | 0.500000E+03 | NBLOCK | = | 0 |
| VRAT | = | -0.666667E+00 | NMAX | = | 100 |
| TSUTH | = | 0.198600E+03 | NC | = | -1 |
| RE | = | 0.000000E+00 | NSPRT | = | 10 |
| PR | = | 0.720000E+00 | NP | = | 0 |
| PRT | = | 0.900000E+00 | IFXPRT | = | 0 |
| DIS2 | = | 0.250000E+00 | IFXPLT | = | 0 |
| DIS4 | = | 0.640000E+00 | L2PLOT | = | 0 |
| DTCAP | = | 0.100000E+04 | IPLOT | = | 0 |
| PCQMAX | = | 0.100000E+02 | LMODE | = | 1 |
| SPLEND | = | 0.100000E+01 | MBORD | = | NBLOCK |
| SMOO | = | 0.000000E+00 | NUMDT | = | 1 |
| STOPL2 | = | 0.100000E-11 | IVARDT | = | 2 |
| STOPTR | = | 0.500000E+01 | ISOLVE | = | 1 |
| ALPHA | = | 0.000000E+00 | IRKORD | = | 4 |
| BETA | = | 0.000000E+00 | IFILTR | = | 1 |
| XMACH | = | 0.000000E+00 | | | |
| IBORD | = | 1, 2, ..., MOS | | | |

5.4.2 NAMELIST SEQDT

The following lists the variables in NAMELIST SEQDT and their default values.

DTSEQ = DTCAP, 0.0, 0.0, 0.0, ...
ITERDT = 1, 0, 0, 0, ...

5.4.3 NAMELIST BLOCK

The following lists the variables in NAMELIST BLOCK and their default values.

INVISC = 1, 1, 1
LAMIN = 0, 0, 0
GAMMA = 1.4
COFMIX = 0.09
DTBLK = 0.0
NPSEG = 0
NBCSEG = 0

5.4.4 NAMELIST PRTSEG

The following lists the variables in NAMELIST PRTSEG and their default values.

JKLPI = 1, JMAX, 1, 1, KMAX, 1, 1, LMAX, 1, 0, 0, ...
IPORD = 2, 1, 0, 0, ...

5.4.5 NAMELIST BOUNDS

Refer to the usage section on boundary conditions (Section 4.8) and the examples appendix (Appendix E) for details on the input parameters in this NAMELIST. There are no default values for these parameters.

REFERENCES

1. Thomas, P. D. "Numerical Method for Predicting Flow Characteristics and Performance of Nonaxisymmetric Nozzles—Theory." Langley Research Center, NASA CR 3147, September 1979.
2. Baldwin, B. S. and Lomax, H. "Thin Layer Approximation and Algebraic Model for Separated Turbulent Flows." AIAA Paper No. 78-257, AIAA 16th Aerospace Sciences Meeting, Huntsville, Alabama, January 1978.

3. Beam, R. and Warming, R. F. "An Implicit Finite Difference Algorithm for Hyperbolic Systems in Conservation Law Form." *Journal of Computational Physics*, Vol. 22, No. 1, September 1976, pp. 87-110.
4. Pulliam, T. H. and Steger, J. L. "Implicit Finite-Difference Simulations of Three Dimensional Compressible Flow." *AIAA Journal*, Vol. 18, No. 2, February 1980, pp. 159-167.
5. Pulliam, T. H. "Euler and Thin Layer Navier-Stokes Codes: ARC2D, ARC3D." *Notes for Computational Fluid Dynamics User's Workshop*, The University of Tennessee Space Institute, Tullahoma, Tennessee, (UTSI Publication E02-4005-023-84), March 12-16, 1984, pp. 15.1-15.85.
6. Jameson, A., Schmidt, W., and Turkel, E. "Numerical Solutions of the Euler Equations by Finite Volume Methods Using Runge-Kutta Time-Stepping Schemes." AIAA Paper No. 81-1259, AIAA 14th Fluid and Plasma Dynamics Conference, Palo Alto, California, 1981.
7. Siclari, M. J., DelGuidice, P., Jameson, A. "A Multigrid Finite Volume Method for Solving the Euler and Navier-Stokes Equations for High Speed Flows." AIAA Paper No. 89-0283, AIAA 27th Aerospace Sciences Meeting, Reno, Nevada, January 1989.

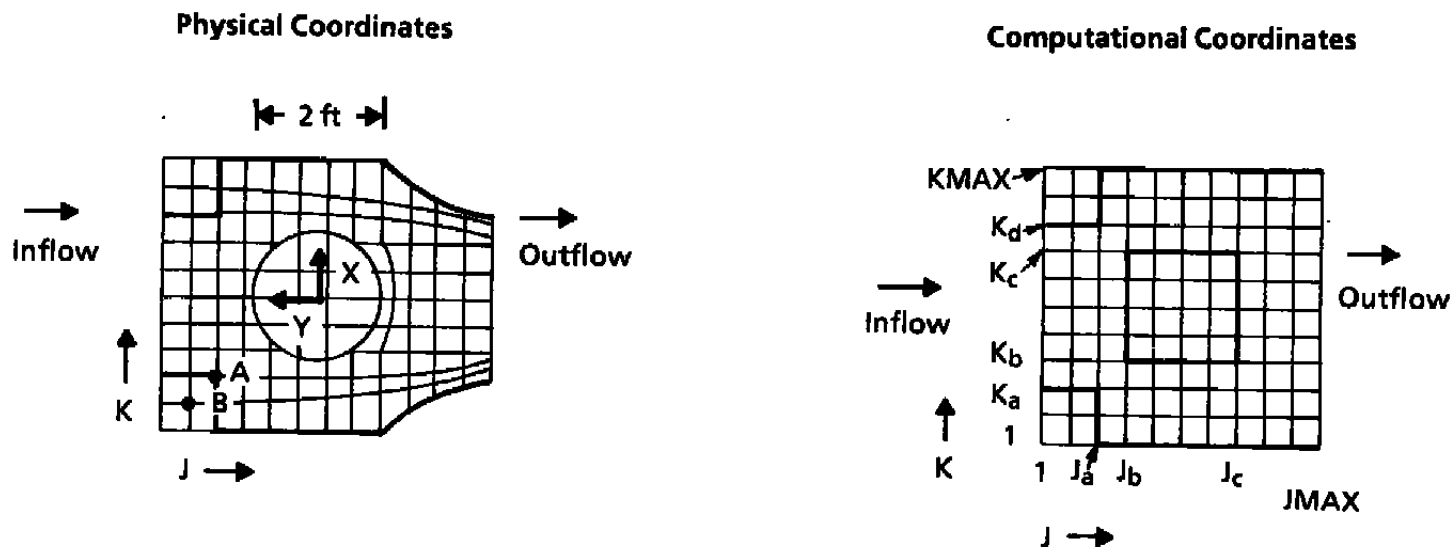

- NOTES:
1. Both the X-Y and J-K coordinate systems are right-handed (hence strictly positive Jacobian).
 2. The coordinates of the point A are $[X(J_a, K_a), Y(J_a, K_a)]$, for example.
 3. Point B is given reasonable coordinates even though it is not a flow field or boundary point.
 4. If X, Y are dimensioned in feet and are not explicitly nondimensionalized, then $X_{ref} = 1$ ft; if X, Y are explicitly nondimensionalized by the cylinder's diameter, then $X_{ref} = 2$ ft.
 5. K_{b-1} and $J_{MAX} - J_c$ must be greater than or equal to three; for example $K_c - K_b$ and $J_a - 1$ are not so restricted; these indices do not bound flow-field points.

Figure 1. Grid concepts.

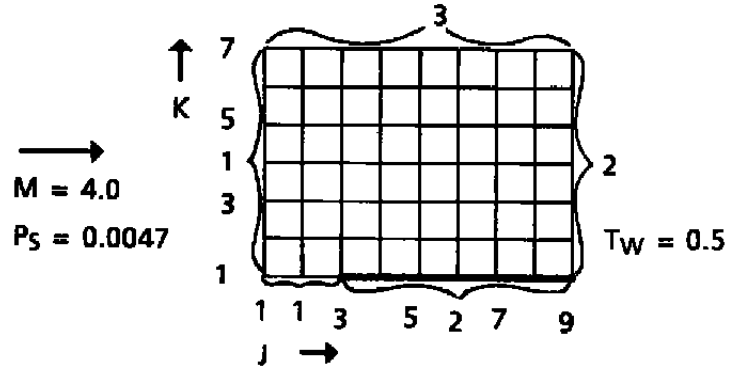

J-Constant Index Class

| Segment Number | J-Index | K-Indices | | Sign of Normal | Boundary Conditions | | |
|----------------|---------|-----------|---------|----------------|---------------------|----------|-------|
| | | Minimum | Maximum | | Type | Pressure | Temp. |
| 1 | 1 | 1 | 7 | 1 | -10 | --- | --- |
| 2 | 9 | 2 | 6 | -1 | 0 | 0.0047 | 1.0 |

K-Constant Index Class

| Segment Number | K-Index | K-Indices | | Sign of Normal | Boundary Conditions | | |
|----------------|---------|-----------|---------|----------------|---------------------|----------|-------|
| | | Minimum | Maximum | | Type | Pressure | Temp. |
| 1 | 1 | 2 | 2 | 1 | 50 | --- | --- |
| 2 | 1 | 3 | 9 | 1 | 61 | --- | 0.5 |
| 3 | 7 | 2 | 9 | -1 | -10 | --- | --- |

Figure 2. Boundary segment specification example.

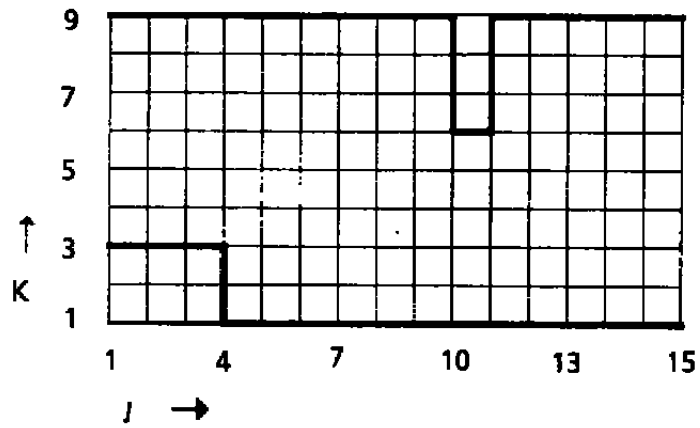

a. Computational grid

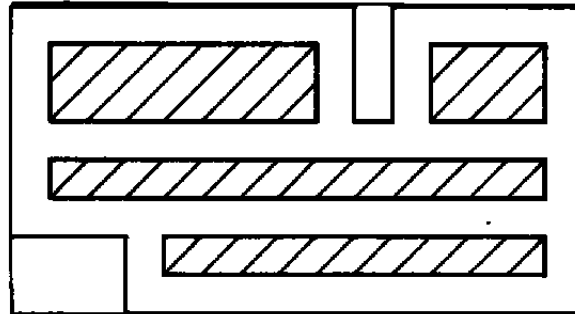

b. J-Patches

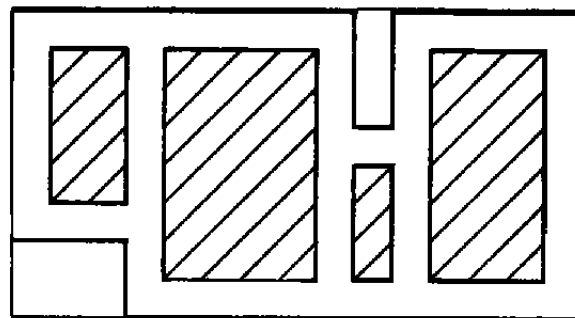

c. K-Patches

Figure 3. Patch generation example.

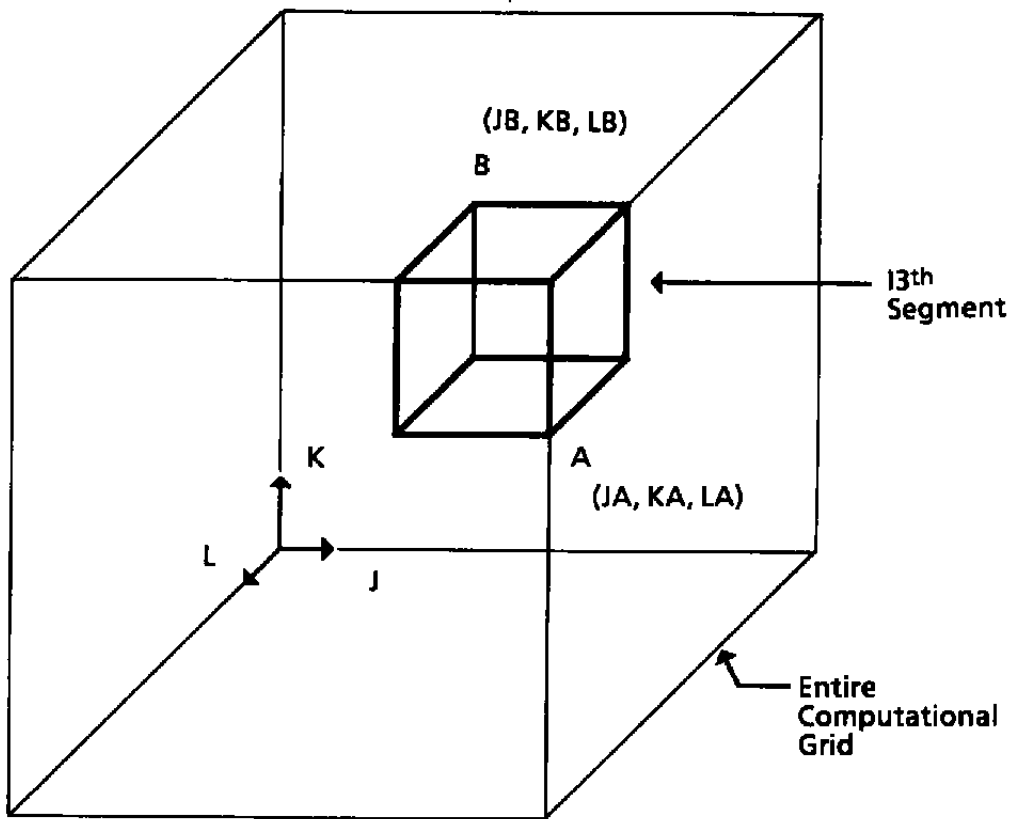

| | | | | |
|----|----|----|----|---|
| | I2 | 1 | 2 | 3 |
| I1 | | | | |
| 1 | JA | KA | LA | |
| 2 | JB | KB | LB | |
| 3 | JI | KI | LI | |

Values of JKLP (I1, I2, I3)

Figure 4. Flow-field print segmentation.

APPENDIX A**NAMELIST PARAMETER GLOSSARY**

- ALPHA** Angle of attack of the free stream. Used only for the free-stream boundary condition (Type 7) and as output to one of the PLOT3D files (See IPLOT). (NAMELIST INPUTS) (Section 4.8).
- BETA** Angle of sideslip of the free stream. Used only for the 3-D free-stream boundary condition (Type 7) and as output to one of the PLOT3D files (See IPLOT). (NAMELIST INPUTS) (Section 4.8).
- COFMIX** The value to be used for the turbulent mixing coefficient for free shear layers (default 0.09). (NAMELIST BLOCK) (Section 4.5).
- DIS2** The coefficient of the second-order artificial viscosity. (NAMELIST INPUTS) (Section 4.6).
- DIS4** The coefficient of the fourth-order artificial viscosity. (NAMELIST INPUTS) (Section 4.6).
- DTBLK** A positive value overrides the global DTCAP for the associated grid block. (NAMELIST BLOCK) (Sections 4.7 and 4.3).
- DTCAP** Maximum time-step size allowed during a run. (NAMELIST INPUTS) (Section 4.7).
- DTSEQ** A vector whose elements specify a sequence of DTCAPs. (NAMELIST SEQDT) (Section 4.7).
- GAMMA** The ratio of specific heats at the reference conditions. (Default value is 1.4) (NAMELIST BLOCK) (Section 4.5).
- IAXISY** Selection parameter for the axisymmetric or 2-D form of the Navier-Stokes equations. (Zero selects 2-D, one selects axisymmetric.) (NAMELIST INPUTS) (Section 4.5).
- IBORD** An integer vector whose elements specify the sequence of grid-block processing. (MBORD elements) (NAMELIST INPUTS) (Section 4.3).

- IFILTR** Selects spectral radius scaling method for the artificial viscosity coefficients. (One selects Jameson-style; two selects cell Reynolds number modification; two selects isotropic and unidirectional blending.) (NAMELIST INPUTS) (Section 4.6).
- IFXPLT** Toggles the construction of a plot file (Unit 21) for flux balance histories. (Zero doesn't; one does.) (NAMELIST INPUTS) (Section 4.9).
- IFXPRT** Toggles the inclusion of flux balance histories in the printed output. (Zero excludes; one includes.) (NAMELIST INPUTS) (Section 4.9).
- INTERJ** Integer vector that specifies the interface identification number for each J-constant boundary segment that forms part of an overlapped boundary. (NJSEG elements) (NAMELIST BOUNDS) (Sections 4.8 and 4.3).
- INTERK** Integer vector that specifies the interface identification number for each K-constant boundary segment that forms part of an overlapped boundary. (NKSEG elements) (NAMELIST BOUNDS) (Sections 4.8 and 4.3).
- INTERL** Integer vector that specifies the interface identification number for each L-constant boundary segment that forms part of an overlapped boundary. (NLSEG elements) (NAMELIST BOUNDS) (Sections 4.8 and 4.3).
- INVISC** An integer vector whose elements toggle viscous effects in the corresponding coordinate direction. (Zero selects inviscid; one selects viscosity.) (NAMELIST BLOCK) (Section 4.5).
- IPLLOT** Toggles the construction of PLOT3D input files (grid on Unit 31, flow field on Unit 30). (Zero doesn't; one does.) (NAMELIST INPUTS) (Section 4.9).
- IPORD** An integer array whose elements determine the order in which the indices are used in printing each segment given by JKLPI. (NAMELIST PRTSEG) (Section 4.9).
- IRKORD** Value selects the order of the pseudo-Runge-Kutta algorithm; has no effect otherwise. (NAMELIST INPUTS) (Section 4.5).
- ISOLVE** Value selects the solution algorithm. (One selects pentadiagonal; zero selects steady-state Runge-Kutta; -1 selects time-accurate Runge-Kutta) (NAMELIST INPUTS) (Section 4.5).

| | |
|---------------|--|
| ITERDT | An integer vector whose elements specify a sequence of iteration limits that are paired up with the elements of DTSEQ. (NAMELIST SEQDT) (Section 4.7). |
| IVARDT | The value of this parameter selects either the time-accurate mode or one of the variable time-step options for the pentadiagonal algorithm. (NAMELIST INPUTS) (Section 4.7). |
| JKHIGH | Integer vector that specifies the largest K-index for each J-constant boundary segment. (NJSEG elements) (Section 4.8). |
| JKLOW | Integer vector that specifies the smallest K-index for each J-constant boundary segment. (NJSEG elements) (Section 4.8). |
| JKLPI | An integer array whose elements specify the coordinate limits and increments for each segment of printed output called for by NPSEG. (NAMELIST PRTSEG) (Section 4.9). |
| JLHIGH | Integer vector that specifies the largest L-index for each J-constant boundary segment. (NJSEG elements) (Section 4.8). |
| JLINE | Integer vector that specifies the J-indices of each of the J-constant boundary segments. (NJSEG elements) (NAMELIST BOUNDS) (Section 4.8). |
| JLLOW | Integer vector that specifies the smallest L-index for each J-constant boundary segment. (NJSEG elements) (Section 4.8). |
| JSIGN | Integer vector that specifies the sign of the surface normal for each J-constant boundary segment. (NJSEG elements) (NAMELIST BOUNDS) (Section 4.8). |
| JTYPE | Integer vector that specifies the appropriate boundary-condition-type code for each J-constant boundary segment. (NJSEG elements) (NAMELIST BOUNDS) (Section 4.8). |
| KJHIGH | Integer vector that specifies the largest J-index for each K-constant boundary segment. (NKSEG elements) (Section 4.8). |
| KJLOW | Integer vector that specifies the smallest J-index for each K-constant boundary segment. (NKSEG elements) (Section 4.8). |

- KLHIGH** Integer vector that specifies the largest L-index for each K-constant boundary segment. (NKSEG elements) (Section 4.8).
- KLIN** Integer vector that specifies the K-indices of each of the K-constant boundary segments. (NKSEG elements) (NAMELIST BOUNDS) (Section 4.8).
- KLLOW** Integer vector that specifies the smallest L-index for each K-constant boundary segment. (NKSEG elements) (Section 4.8).
- KSIGN** Integer vector that specifies the sign of the surface normal for each K-constant boundary segment. (NKSEG elements) (NAMELIST BOUNDS) (Section 4.8).
- KTYPE** Integer vector that specifies the appropriate boundary-condition-type code for each K-constant boundary segment. (NKSEG elements) (NAMELIST BOUNDS) (Section 4.8).
- L2PLOT** Toggles the construction of a plot file (Unit 21) for L₂ residual histories. (Zero doesn't; one does.) (NAMELIST INPUTS) (Section 4.9).
- LAMIN** An integer vector whose elements toggle turbulent viscosity. (NAMELIST BLOCK) (Section 4.5).
- LJHIGH** Integer vector that specifies the largest J-index for each L-constant boundary segment. (NLSEG elements) (Section 4.8).
- LJLOW** Integer vector that specifies the smallest J-index for each L-constant boundary segment. (NLSEG elements) (Section 4.8).
- LKHIGH** Integer vector that specifies the largest K-index for each L-constant boundary segment. (NLSEG elements) (Section 4.8).
- LKLOW** Integer vector that specifies the smallest K-index for each L-constant boundary segment. (NLSEG elements) (Section 4.8).
- LLINE** Integer vector that specifies the L-indices of each of the L-constant boundary segments. (NLSEG elements) (NAMELIST BOUNDS) (Section 4.8).
- LMODE** Toggles metric recalculations for blocked grids. (One doesn't; two does.) (NAMELIST INPUTS) (Section 4.3).

| | |
|---------------|--|
| LSIGN | Integer vector that specifies the sign of the surface normal for each L-constant boundary segment. (NLSEG elements) (NAMELIST BOUNDS) (Section 4.8). |
| LTYPE | Integer vector that specifies the appropriate boundary-condition-type code for each L-constant boundary segment. (NLSEG elements) (NAMELIST BOUNDS) (Section 4.8). |
| MBC | Specifies the maximum values of NJSEG, NKSEG, and NLSEG.(PARAMETER statements) (Section 5.1). |
| MBORD | The length of the sequence given by IBORD. (NAMELIST INPUTS) (Section 4.3). |
| MEMORY | Specifies the maximum number of words of high-speed memory available to the PARC code. (PARAMETER statements) (Section 5.1). |
| MOS | Specifies the maximum values of MBORD and NUMDT. (PARAMETER statements) (Section 5.1). |
| MP | Specifies the maximum number of patches per grid block.(PARAMETER statements) (Section 5.1). |
| MPS | Specifies the maximum value of NPSEG. (PARAMETER statements) (Section 5.1). |
| MXNB | Specifies the maximum number of grid blocks. (PARAMETER statements) (Section 5.1). |
| NBCSEG | Toggles the method of boundary-condition specification. (Zero selects NAMELIST BOUNDS; positive value selects formatted input and determines the total number of boundary segments.) (NAMELIST BLOCK) (Section 4.8). |
| NBLOCK | The number of blocks. (NAMELIST INPUTS) (Section 4.3). |
| NC | Nonnegative value resets the iteration count to the value specified by this parameter. (NAMELIST INPUTS) (Section 4.7). |
| NIP | Specifies the maximum number of grid points on any face of any block. (PARAMETER statements) (Section 5.1). |

| | |
|---------------|--|
| NJSEG | The total number of boundary segments for the J-constant coordinate class. (NAMELIST BOUNDS) (Section 4.8). |
| NKSEG | The total number of boundary segments for the K-constant coordinate class. (NAMELIST BOUNDS) (Section 4.8). |
| NLSEG | The total number of boundary segments for the L-constant coordinate class. (NAMELIST BOUNDS) (Section 4.8). |
| NM | Specifies the maximum number of grid points on any edge of any block. (PARAMETER statements) (Section 5.1). |
| NMAX | Maximum number of iterations to be performed during the current execution of the PARC program. (NAMELIST INPUTS) (Section 4.7). |
| NP | Specifies the print frequency of selected flow-field values. (NAMELIST INPUTS) (Section 4.9). |
| NPSEG | Specifies the number of flow-field segments in the associated NAMELIST PRTSEG. (NAMELIST BLOCK) (Section 4.9). |
| NSPRT | Specifies the print frequency of the convergence history. (NAMELIST INPUTS) (Section 4.9). |
| NUMDT | Toggles time-step sequencing. A positive value selects this option and provides the number of sequencing steps. (NAMELIST INPUTS) (Section 4.7). |
| PCQMAX | Maximum percent change in either density or pressure allowed during an iteration. Recommended range is between 1 and 25. (NAMELIST INPUTS) (Section 4.7). |
| PR | Prandtl number at reference conditions. (NAMELIST INPUTS) (Section 4.5). |
| PREF | Scaling factor used to dimensionalize pressures in the printed output. (NAMELIST INPUTS) (Section 4.9). |
| PRESSJ | Vector that specifies certain auxiliary variables (usually pressure) for each J-constant boundary segment. (NJSEG elements) (NAMELIST BOUNDS) (Section 4.8). |

- PRESSK** Vector that specifies certain auxiliary variables (usually pressure) for each K-constant boundary segment. (NKSEG elements) (NAMELIST BOUNDS) (Section 4.8).
- PRESSL** Vector that specifies certain auxiliary variables (usually pressure) for each L-constant boundary segment. (NLSEG elements) (NAMELIST BOUNDS) (Section 4.8).
- PRT** Turbulent Prandtl number. (NAMELIST INPUTS) (Section 4.5).
- RE** Reynolds number based on the reference density, speed of sound, length, and viscosity. There is no default for viscous flows. (NAMELIST INPUTS) (Section 4.5).
- SMOO** Used only with the Runge-Kutta solver (i.e., when ISOLVE is 0 or -1). A positive value implements the implicit residual smoothing option. (NAMELIST INPUTS) (Section 4.6).
- SPLEND** Artificial viscosity blending control. A value between 0 and 1 gives a weighted average of isotropic and split-direction artificial dissipation. (NAMELIST INPUTS) (Section 4.6).
- STOPL2** Value of the L_2 residual at which the current execution of the PARC code is to be terminated. (NAMELIST INPUTS) (Section 4.7).
- STOPTR** The amount of computer time (in seconds) before the program execution time limit is reached at which normal program termination is to commence. (NAMELIST INPUTS) (Section 4.7).
- TEMPJ** Vector that specifies certain auxiliary variables (usually temperature) for each J-constant boundary segment. (NJSEG elements) (NAMELIST BOUNDS) (Section 4.8).
- TEMPK** Vector that specifies certain auxiliary variables (usually temperature) for each K-constant boundary segment. (NKSEG elements) (NAMELIST BOUNDS) (Section 4.8).
- TEMPL** Vector that specifies certain auxiliary variables (usually temperature) for each L-constant boundary segment. (NLSEG elements) (NAMELIST BOUNDS) (Section 4.8).

- TREFR** Reference temperature in degrees Rankine. The only uses are to nondimensionalize the Sutherland temperature (TSUTH) and to dimensionalize temperatures in the printed output. (NAMELIST INPUTS) (Sections 4.5 and 4.9).
- TSUTH** Sutherland viscosity law temperature (frequently denoted as S) in degrees Rankine. (NAMELIST INPUTS) (Section 4.5).
- VRAT** Ratio of the second coefficient of viscosity to the first coefficient of viscosity. (Default is $-2/3$, which is Stokes hypothesis.) (NAMELIST INPUTS) (Section 4.5).
- XMACH** Mach number of the free stream. Used only for the free-stream boundary condition (Type 7) and as output to one of the PLOT3D files (See IPLOT). (NAMELIST INPUTS) (Section 4.8).

APPENDIX B**TRANSPORTABILITY**

The PARC code is written in CRAY FORTRAN and uses some CRAY extensions and library routines that might require modification to implement on some other scientific computers. Most notably, they use POINTER statements to dynamically allocate arrays. These could be replaced by writing a subroutine to allocate the arrays and by passing all the arrays as arguments. The CRAY library subroutines used, and their functions are listed as follows:

- RELEASE** Releases buffers used by an input file that are no longer needed. The call to this routine can be deleted.
- TREMAIN** Provides the time remaining in the computer job.
- CVMGT** This function has three arguments, the third being a logical. If the logical is true, the first function is returned; if false, the second. The function is an aid to CRAY vectorization and can be replaced with IF statements.
- PACK21** Packs two words into one by truncating the least significant bits. PACK21 is used to compress data before writing to temporary external storage. This reduces such output by a factor of two. This is a significant savings for ordinary disk storage, but is less important if a CRAY Solid-State Storage Device (SSD) is available. The use of this routine is not essential.
- EXPAND21** Reverses the effect of PACK21, obviously with loss of precision. EXPAND21 is used to expand packed data after reading it. This reduces such input by a factor of two. The use of this routine is not essential (unless PACK21 is also used).
- OPENMS** This routine opens for input and output a variable length direct-access file. Equivalent methods of direct-access read and write routines exist for most scientific computers.
- READMS** Reads a record from a variable length direct-access file.
- WRITMS** Writes a record to a variable length direct-access file.
- CLOSMS** This routine closes a variable length direct-access file.

APPENDIX C

ERROR MESSAGES

A limited amount of error checking is performed by the PARC code. Most of this is confined to the detection of input problems. Execution error detection is intended to initiate an orderly end of the run when a gross error occurs. The error messages printed on Unit 6 (FT06) and explanations of their meanings are listed in this appendix in alphabetical order. A lowercase word (e.g., "value") is used wherever a numerical value would be printed and the lowercase word "name" is used wherever a variable's name would be printed.

*******INTERFACE USAGE NUMBER IS INCORRECT FOR INTERFACE value*******

This message will be caused by violating one of the following six rules:

1. Interface numbers must be in pairs.
2. Only Types 70, 71, 73, and 77 boundary conditions can have interface numbers.
3. A Type 70 boundary condition must be paired with a Type 70 boundary condition and both boundaries must have the same number of points.
4. A Type 71 boundary condition must be paired with either a Type 71 or 73 boundary condition.
5. A Type 73 boundary condition must be paired with a Type 71 boundary condition.
6. A Type 77 boundary condition must be paired with a Type 77 boundary condition.

******* INVALID *******

If an invalid boundary-condition type has been specified, this message will appear as its description, and program execution will terminate.

INVALID VALUE FOR SPLEND = value

The value of SPLEND must be greater or equal to zero and less than or equal to one.

NEWTON ITERATION FOR PRESSURE IN SUBROUTINE INSUB FAILED TO CONVERGE

J, K, L, ID, P, PP = value, value, value, value, value, value

This error terminates execution of the PARC code with no restart file created. The variables on the second line have the following meanings:

- J, K, L** grid coordinates for the point in error;
- ID** boundary identifier, the numbers 1, 2, and 3 are associated with J-, K-, and L-constant boundaries;
- P** pressure on the boundary; and
- PP** pressure just off the boundary.

Occurrence of this error condition almost always indicates an incompatibility between a boundary-condition value and the interior flow. First try lowering the value of DTCAP (say by half). If this condition happens on the initial run of a flow simulation, it can usually be cleared up by taking more care in the generation of initial conditions.

PARAMETER MOS MUST BE INCREASED TO > OR = MBORD.

A block processing sequence longer than allowed has been specified. Either the sequence will have to be shortened or else the value of the PARAMETER, MOS, will have to be changed everywhere it occurs.

PATCH ERROR:

This message will then be followed by one of the following lines for PARC3D:

J-PATCH AND K-PATCH WITH NO L-PATCH
 K-PATCH AND L-PATCH WITH NO J-PATCH
 J-PATCH AND L-PATCH WITH NO K-PATCH
 J-PATCH WITH NO K-PATCH OR L-PATCH
 K-PATCH WITH NO J-PATCH OR L-PATCH
 L-PATCH WITH NO J-PATCH OR K-PATCH

And then the patch mismatch information,

IN REGION BOUNDED BY THE J, K, L POINTS: (Jmin, Kmin, Lmin), (Jmax, Kmax, Lmax)

For PARC2D applications, the first line will be followed by one of

**J-PATCH HAS NO CORRESPONDING K-PATCH
K-PATCH HAS NO CORRESPONDING J-PATCH**

And then the patch mismatch information,

IN REGION BOUNDED BY THE J, K POINTS: (Jmin, Kmin), (Jmax, Kmax)

As mentioned in the Output section (Section 4.9), this information in combination with the grid patch summary should provide clues to the boundary specification error that produced this error condition. For example, consider the hypothetical fluid flow problem depicted in Fig. C-1a and suppose the printed echo of the BOUNDS NAMELIST input were

| KSEG | KLINE | KJLOW | KJHIGH | KYTPE | KSIGN | PRESSK | TEMPK |
|------|-------|-------|--------|-------|-------|--------|-------|
| 1 | 1 | 10 | 13 | 60 | 1 | 0.0 | 0.0 |
| 2 | 9 | 1 | 13 | 61 | -1 | 0.0 | 0.5 |
| 3 | 5 | 1 | 7 | 60 | 1 | 0.0 | 0.0 |
| JSEG | JLINE | JKLOW | JKHIGH | JTYPE | JSIGN | PRESSJ | TEMPJ |
| 1 | 7 | 2 | 4 | 60 | 1 | 0.0 | 0.0 |
| 2 | 1 | 6 | 8 | 0 | 1 | 0.7143 | 1.0 |
| 3 | 13 | 2 | 8 | 0 | -1 | 0.7 | 1.0 |

Note that the value of KJLOW(1) is in error. (It should be 7.) This input would create the grid patches shown in Fig. C-1b and c, which would cause the following error message to be printed:

*******PATCH ERROR:**

**J-PATCH HAS NO CORRESPONDING K-PATCH
IN REGION BOUNDED BY THE J, K POINTS:
(8,2), (10,5)**

This would be listed just after the grid patch table as follows:

| J-PATCHES | MINIMUM | | MAXIMUM | |
|-----------|---------|---|---------|---|
| | J | K | J | K |
| 1 | 8 | 2 | 12 | 5 |
| 2 | 2 | 6 | 12 | 8 |

| K-PATCHES | MINIMUM | | MAXIMUM | |
|-----------|---------|---|---------|---|
| | J | K | J | K |
| 1 | 2 | 6 | 9 | 8 |
| 2 | 10 | 2 | 12 | 8 |

Examination of these listings (if necessary, including construction of diagrams similar to those of Fig. C-1) leads to the conclusion that the incorrect grid patch is K-patch Number 1. This must be caused by an incorrect boundary specification for K-segment 1 or 3. Finally examination of these segments' indices reveals that the lower J-index of K-segment Number 1 is incorrect.

RANGE ERROR:

This message will then be followed by one of the following lines depending on whether a scalar parameter or a vector parameter, respectively, is in error:

```
name = value IS OUT OF RANGE (minimum, maximum)
name(index) = value IS OUT OF RANGE (minimum, maximum)
```

where "name" is the symbolic name of the input parameter (e.g., JMAX), "value" is the input value of this parameter, "minimum" and "maximum" are the smallest and largest, respectively, values allowed for this parameter, and "index" is the element number of the parameter vector that is in error. This error condition only occurs during program initiation for certain input parameters that are checked for valid values. Correction of these errors is normally self-explanatory.

STOPPING: AT ITERATION NUMBER: iteration

THE TIME-STEP IS SMALLER THAN THE MINIMUM: time-step

This error message usually occurs when the PARC code would like to "blowup" but can't because of the time-step limiting feature of the program. The iteration count is given by "iteration" and the minimum allowed time-step size (10^{-7} as set by DTMIN in a DATA statement in SUBROUTINE MAXDT) is given by "time-step." This error allows the code to terminate in a normal fashion, at this iteration, with printed output and a restart file. However, the restart file is usually only good for plots and not for restarting the calculation. In most cases this condition indicates that the value of the input parameter DTCAP is too large. Thus, restarting from the previous restart file with a smaller value of DTCAP should be attempted. This error can also arise if boundary conditions are in error or are very much different from the interior flow conditions.

STOPPING IN BCAVG, NPTS = value WHY ARE YOU TRYING TO AVERAGE LESS THAN 2 POINTS?

An averaging boundary condition has been specified, and the number of points to be averaged is less than two. Either the boundary-condition type or the range of indices has been specified incorrectly.

**STOPPING IN BLOCK block—DENSITIES AND/OR PRESSURES ARE NONPOSITIVE
NC = iteration**

| | | | | |
|---|---|---|---------|----------|
| J | K | L | DENSITY | PRESSURE |
| j | k | l | density | pressure |

The values symbolized by the lowercase letters are continued to include all such points or until 100 occurrences happen. The densities and pressures are checked at the end of each iteration to determine if any are nonpositive (a physically unrealistic and an unrecoverable error). If any are, then a normal termination of the program execution is attempted. The restart file generated is useful only for plotting purposes. This error rarely occurs and typically is recovered from in the same manner as described in the "THE TIME-STEP IS SMALLER..." error above.

STOPPING—INVALID BC, JLINE = value
STOPPING—INVALID BC, KLINE = value
STOPPING—INVALID BC, LLINE = value

The first of these three messages is caused by specifying a Type 81 boundary condition for a J-constant boundary. The second digit of the averaging boundary condition specifies the index over which the average is to be calculated. Obviously, the average is not to be over the constant-value index. Similarly, the second message is caused by specifying a Type 82 boundary condition for a K-constant boundary; and the third message is caused by specifying a Type 83 boundary condition for an L-constant boundary.

STOPPING—JACOBIANS ARE NONPOSITIVE

| | | | |
|---|---|---|----------|
| J | K | L | JACOBIAN |
| j | k | l | jacobian |

The values symbolized by the lowercase letters are continued to include all such points or until 100 occurrences happen. This error condition either indicates that some of the grid lines cross or collapse to a single line, or that the physical coordinate system (X, Y, Z) and

the computational coordinate system (J, K, L) have different handedness. The grid must be "fixed."

STOPPING—L2 RESIDUAL HAS CONVERGED TO SPECIFIED LEVEL L2

RESIDUAL: level ITERATION NUMBER: iteration

This is not really an error message. It indicates that the L_2 residual has decreased to below the level specified by the input parameter STOPL2. Normal print and restart files are generated.

STOPPING—RE MUST BE INPUT FOR VISCOUS FLOWS

Basically self-explanatory, the Reynolds number, RE, must be provided for viscous flows (i.e., when LAMIN has one or more nonzero elements).

STOPPING—TIME REMAINING IS time SECONDS

L2 RESIDUAL: level ITERATION NUMBER: iteration

This is not really an error message. It indicates that the time remaining is less than that specified by the input parameter STOPTR. Normal print and restart files are generated.

STOPPING—TOO MANY B.C'S

INCREASE 'MBC' PARAMETER

This error condition is only detected if the boundary conditions are input through a formatted read rather than through NAMELIST BOUNDS (See Section 4.8). It declares that the boundary segment vectors are DIMENSIONED too small for the number of segments supplied in the input. Change the value of the MBC parameter in every PARAMETER statement in which it occurs to a value large enough to accommodate the maximum number of segments.

STOPPING—TOO MANY SEGMENTS

INCREASE 'MP' PARAMETER

The number of patches generated for one or more of the patch classes (See Section 4.9) is greater than allowed for by the value of the parameter MP. Since the maximum number of patches is usually not known prior to program execution, try doubling the current value of MP in all of the PARAMETER statements in which it occurs. To make optimal use of memory, this parameter should be adjusted to reflect the maximum number of patches in

any of the coordinate classes as given by the patch tabulation in the printed output of an initial, short, run. Note that this error frequently indicates that some of the boundaries have been misspecified.

UNDEFINED OPTION IFILTR = value

The specified value for IFILTR is invalid. Specify a valid value (1, 2, or 3).

UNDEFINED OPTION ISOLVE = value

The specified value for ISOLVE is invalid. Specify a valid value (1, 0, or -1).

*******WARNING---PREF DEFAULTED TO 14.7 PSI**

This message is self-explanatory. It warns the user that the reference pressure was not specified and that the default value will be used. This only affects the printed pressure output.

*******WARNING---TREFR DEFAULTED TO 500 DEG R**

This message is self-explanatory. It warns the user that the reference temperature was not specified and that the default value will be used. This affects the printed temperature output and the Sutherland viscosity law, if the simulated flow is viscous.

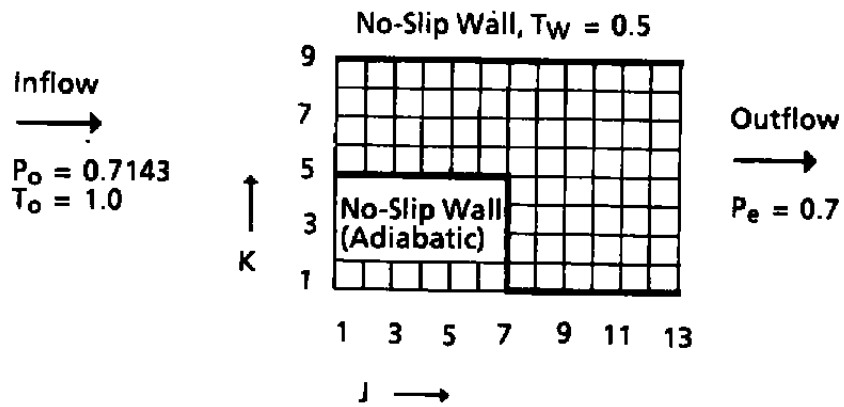

a. Computation grid

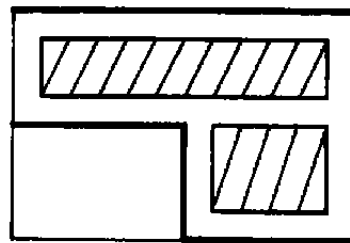

b. J-Patches

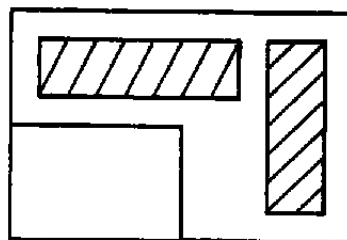

c. K-Patches

Figure C-1. Patch error example.

0

APPENDIX D

PARC CODE VERSION DIFFERENCES

This Appendix is intended to give a brief overview of the important usage differences between the version of the PARC code described in the previous PARC code technical report (AEDC-TR-87-24) and the version covered in this technical report.

D-1.0 DIFFERENCES IN CAPABILITIES

Four major new enhancements have been added to the PARC code, grid blocking, a selection of artificial dissipation models, a time-accurate psuedo-Runge-Kutta algorithm, and additional boundary conditions.

D-1.1 GRID BLOCKING

Grid blocking was incorporated into the PARC code primarily to circumvent high-speed computer memory limitations. It also simplifies grid generation about complex geometries and admits grid-embedding techniques. Communication between grid blocks is accomplished through the overlapping of grids. Although the PARC code permits block interfaces that do not possess an exact match of grid points between adjoining grid blocks, the blocking algorithm will give best results if there is a point-to-point correspondence in the overlap regions. See Section 4.3 for further details on the purpose of and usage concepts for the blocking algorithm.

D-1.2 ARTIFICIAL DISSIPATION

A number of ways are provided for modifying the variable part of the artificial viscosity coefficients. The most robust (and diffusive) method is to use the version included with the older PARC code (the isotropic option). A viscous correction to the artificial viscosity may be selected for flows with sharp gradients through the shear layers (e.g., some hypersonic flows). A nonisotropic artificial dissipation coefficient, which is based upon a separate formulation for each coordinate direction, may be chosen for the best accuracy. However, this option is not as robust as the original dissipation model. Finally, a compromise artificial viscosity model may be selected that gives a nonlinear weighted average of the isotropic and nonisotropic approaches. See Section 4.6 for further details.

D-1.3 TIME ACCURACY

The PARC code can be used to simulate transient flow problems. For this purpose two simulation techniques are selectable. One is the original pentadiagonal solver. Although this

algorithm is the most efficient way to simulate transient flows, it does not track shocks or other strong gradients very accurately. For better time-accuracy, a pseudo-Runge-Kutta solver may be selected. A three-, four-, or five-stage scheme may be chosen for this algorithm. For additional details on these time-accurate simulation options, refer to Section 4.5.

D-1.4 BOUNDARY CONDITIONS

New boundary conditions have been added in two areas. The first is to support the grid-blocking concept (Section 4.3). The second is to add flexibility to the types of grids and flow conditions that the PARC code can treat without modification. A brief description of these new boundary-condition types is listed as follows. See Section 4.8 for further details.

| | |
|------------------------|---|
| Extrapolation | Extrapolates all flow-field variables. |
| Free Stream | External flow far-field boundary condition. Similar to the "Free" boundary condition (Type 0). |
| Contiguous | Describes a block-interface boundary for which there is a point-to-point match of grid points between blocks. |
| Noncontiguous | Describes a block-interface boundary that is not contiguous (See previous entry). |
| Pressure | Pressure is kept continuous between grid blocks with different GAMMAs. |
| Averaging (2-D) | Singular boundary condition for degenerate (collapsed) boundary line. The average of extrapolated flow variables. |
| Averaging (3-D) | Singular boundary condition for degenerate (collapsed) surface. The average of extrapolated flow variables. |

D-2.0 DIFFERENCES IN INPUT FILES

Both the restart file and the parameter (NAMELIST) file have changed in format and content. The restart file now contains the grid dimensions (JMAX, KMAX, and LMAX) for each grid block and the grids and flow fields for each block. The manner in which it is read (and written) has also slightly changed. See Section 5.3 for details. Changes in the parameter file include the addition of a new NAMELIST (BLOCK), the inclusion of new input parameters (See the following), and a rearrangement of the placement of the parameters

in the NAMELISTs. Refer to the Section on File Usage for a description of the organization of the parameter file and the NAMELISTs in it (Also see Appendix E).

D-3.0 DIFFERENCES IN INPUT PARAMETERS

A number of PARAMETER statements and NAMELIST input parameters have been either replaced, changed, or added in this version of the PARC code as compared to the version of AEDC-TR-87-24.

D-3.1 REPLACED

The only input parameters to be completely replaced were the array dimensioning parameters in the FORTRAN PARAMETER statements. Since the PARC code now essentially dynamically dimensions the storage arrays for each grid block, the previously used PARAMETER statement parameters NX, NY, NZ, and NM are no longer used. Instead the user specifies the high-speed computer memory requirements through the new parameters MEMORY and NIP. Refer to Section 5.1 for details on this new usage.

D-3.2 CHANGED

The following input parameters were used in the old version of the PARC code, but now have slightly different effects. Refer to the referenced sections of this report for a fuller explanation of their altered purposes and usages.

IVARDT Description: Selects either the time-accurate mode or one of the variable time-step options for the pentadiagonal algorithm. Change: Ignored when the Runge-Kutta algorithm is used. (NAMELIST INPUTS) (Sections 4.7 and 4.5)

NMAX Description: Maximum number of iterations to be performed during the current execution of the PARC program. Change: Negative value causes the PARC code to perform initialization checks of the input parameters and restart file and then terminates with normal output, including printed flow-filed snapshot(s). (NAMELIST INPUTS) (Section 4.7)

D-3.3 NEW

A number of new user selectable parameters have been added to the PARC code. Most of these support the use of the new PARC capabilities discussed above. These new parameters

are briefly described below; refer to the referenced sections of this report for a fuller explanation of their purposes and usages.

| | |
|---------------|--|
| ALPHA | Angle of attack of the free stream. Used for free-stream boundary condition (Type 7). (NAMELIST INPUTS) (Section 4.8). |
| BETA | Angle of sideslip of the free stream. Used for free-stream boundary condition (Type 7). (NAMELIST INPUTS) (Section 4.8). |
| COFMIX | Turbulent mixing coefficient for free shear layers. (NAMELIST BLOCK) (Section 4.5). |
| DTBLK | Grid-block specific DTCAP. (NAMELIST BLOCK) (Sections 4.7 and 4.3). |
| IBORD | The sequence of grid-block processing. (NAMELIST INPUTS) (Section 4.3). |
| IFILTR | Spectral radius scaling method for the artificial viscosity. (NAMELIST INPUTS) (Section 4.6). |
| INTERJ | Interface identification number for J-constant block boundary segments. (NAMELIST BOUNDS) (Sections 4.8 and 4.3). |
| INTERK | Interface identification number for K-constant block boundary segments. (NAMELIST BOUNDS) (Sections 4.8 and 4.3). |
| INTERL | Interface identification number for L-constant block boundary segments. (NAMELIST BOUNDS) (Sections 4.8 and 4.3). |
| IPLOT | Toggles construction of PLOT3D files. (NAMELIST INPUTS) (Section 4.9). |
| IRKORD | Order of the pseudo-Runge-Kutta algorithm. (NAMELIST INPUTS) (Section 4.5). |
| ISOLVE | Selects the solution algorithm. (NAMELIST INPUTS) (Section 4.5). |
| LMODE | Toggles metric recalculations for blocked grids. (NAMELIST INPUTS) (Section 4.3) |

| | |
|---------------|--|
| MBORD | Length of IBORD sequence. (NAMELIST INPUTS) (Section 4.3). |
| MEMORY | Maximum number of words of high-speed memory. (PARAMETER statements) (Section 5.1). |
| NBLOCK | Number of blocks. (NAMELIST INPUTS) (Section 4.3). |
| NIP | Maximum number of grid points on any face of any block. (PARAMETER statements) (Section 5.1). |
| PRT | Turbulent Prandtl number. (NAMELIST INPUTS) (Section 4.5). |
| SMOO | Selects Runge-Kutta implicit residual smoothing option. (NAMELIST INPUTS) (Section 4.6). |
| SPLEND | Artificial viscosity blending control. (NAMELIST INPUTS) (Section 4.6). |
| STOPTR | The amount of computer time (in seconds) before the program execution time limit is reached at which normal program termination is to commence. (NAMELIST INPUTS) (Section 4.7). |
| XMACH | Mach number of the free stream. Used for the free-stream boundary condition. (NAMELIST INPUTS) (Section 4.8). |

D-4.0 DIFFERENCES IN OUTPUT

The principal differences in output between the new version of the PARC code and the older version are in the format of the restart file, certain additions to the printed output, and the option of creating a PLOT3D plot file. The differences in the restart file are covered previously in the discussion on input file differences. Printed output from the PARC code remains the same as with the old version, except that the new and changed input parameters are printed in the appropriate places and the blocking feature requires that additional information be printed for each block. In particular, boundary conditions, patching information, and flow-field snapshots are printed by block. Further details on the control of the printed output can be found in Section 4.9, and examples of the format of this output can be found in Appendix E.

APPENDIX E

EXAMPLES

Consider the sample problem diagramed in Fig. E-1. This is a 2-D diverging nozzle flow with straight duct segments at each end of the nozzle. The desired operating conditions are also indicated on the figure. First, an execution of the PARC2D code for this example will be presented.

E-1.0 2-D DIVERGING NOZZLE

The grid and initial conditions were generated using the program of Listing E-1. A total of 33 equally spaced J-coordinate lines and 11 K-coordinate lines were used, as shown in Fig. E-2. The initial conditions were appropriate to a free-streaming flow at Mach 0.29 and a ratio of specific heats of 1.4. These initial conditions and grid were stored in the file ICCASE1.

The execution file is displayed in Listing E-2. Note that 2-D, inviscid flow has been specified and that, for this simple flow, the artificial viscosity coefficients are at their practical minimums. The printed output is presented in Listing E-3. A sample Mach number contour plot of the converged solution is shown in Fig. E-3.

E-2.0 3-D DIVERGING NOZZLE

This example problem is exactly the same as the 2-D diverging nozzle problem except that the nozzle has a width of 5 and has 21 L-coordinate lines across this width. The grid and initial conditions were produced by the program in Listing E-4. The execution file including the NAMELIST inputs to the PARC3D code are shown in Listing E-5. The corresponding printed output is in Listing E-6. Mach contours for a 2-D slice of this problem are shown in Fig. E-4.

E-3.0 CONTIGUOUS BLOCK INTERFACE

This is the same problem as the first example, except the grid is decomposed into three grid blocks. The grid and initial conditions were produced by the program in Listing E-7. The execution file including the NAMELIST inputs to the PARC2D code are shown in Listing E-8. The corresponding printed output is in Listing E-9. The solution does not continue to converge after approximately 1,600 iterations; this is caused by the use of reduced precision input/output. Minor code changes can be made to convert to full-precision input/output, which will permit convergence of the same order of magnitude as the previous examples. Mach contours and grid-block boundaries are shown in Fig. E-5.

E-4.0 NONCONTIGUOUS BLOCK INTERFACE

Again the 2-D diverging nozzle problem is solved using three grid blocks, except one of the grid blocks has increased grid resolution. The program in Listing E-10 generated the grid, shown in Fig. E-6, and the initial conditions. The execution file, including the NAMELIST inputs, are shown in Listing E-11. The PARC2D code printed output is shown in Listing E-12; again note the stalled convergence caused by reduced precision block input/output. Mach contours for the converged solution are shown in Fig. E-7.

Inflow Boundary Condition
P_{TOTAL} = 15 psia
T_{TOTAL} = 600°R
Flow Angle = 0 deg

Outflow Boundary Condition
P_{STATIC} = 14.13 psia

Reference Conditions
P_{REF} = 15 psia
T_{REF} = 600°R
γ = 1.4

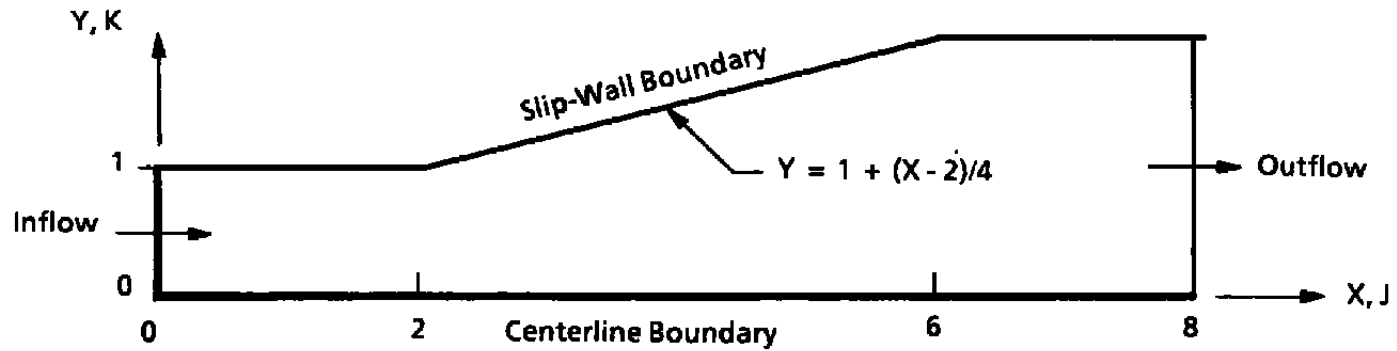

Figure E-1. Diverging nozzle example.

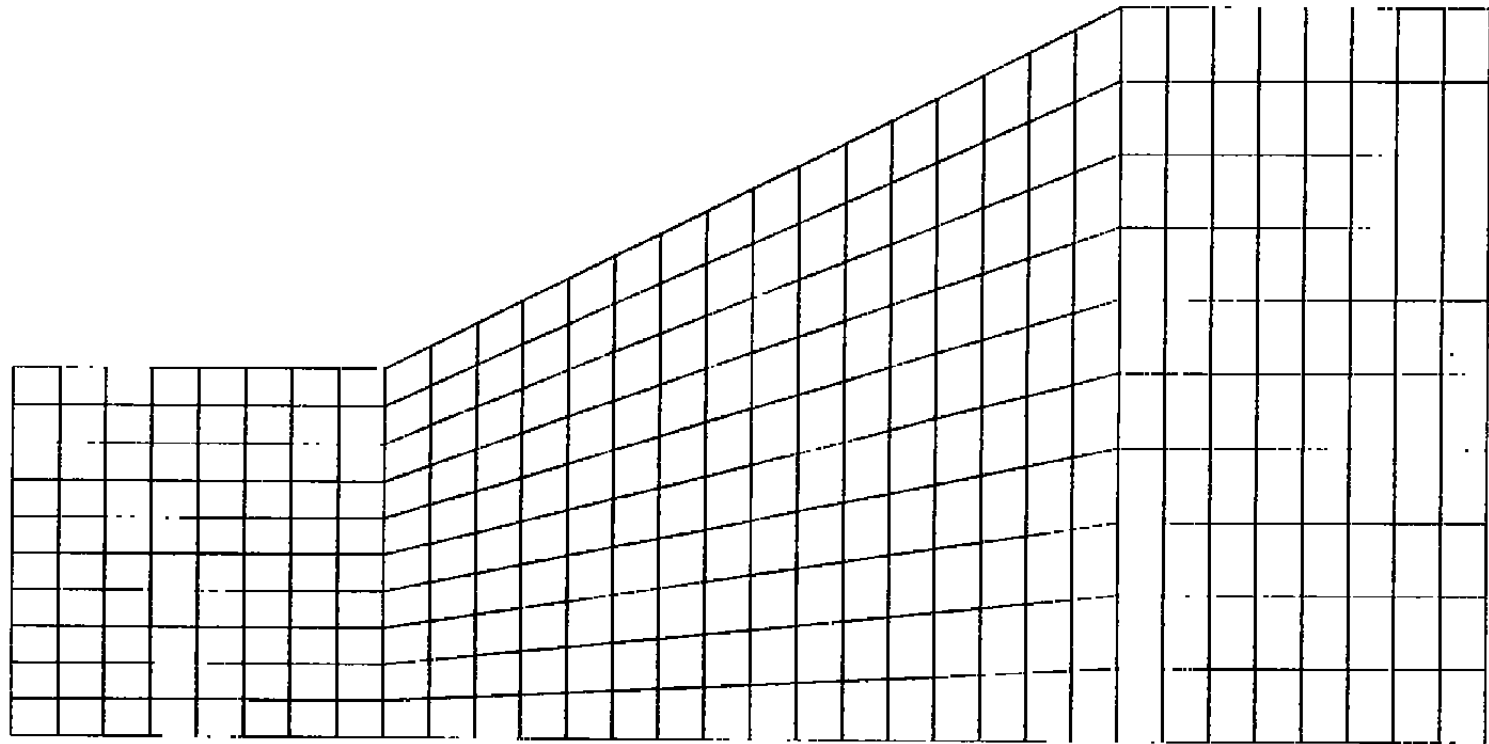

Figure E-2. Diverging nozzle grid.

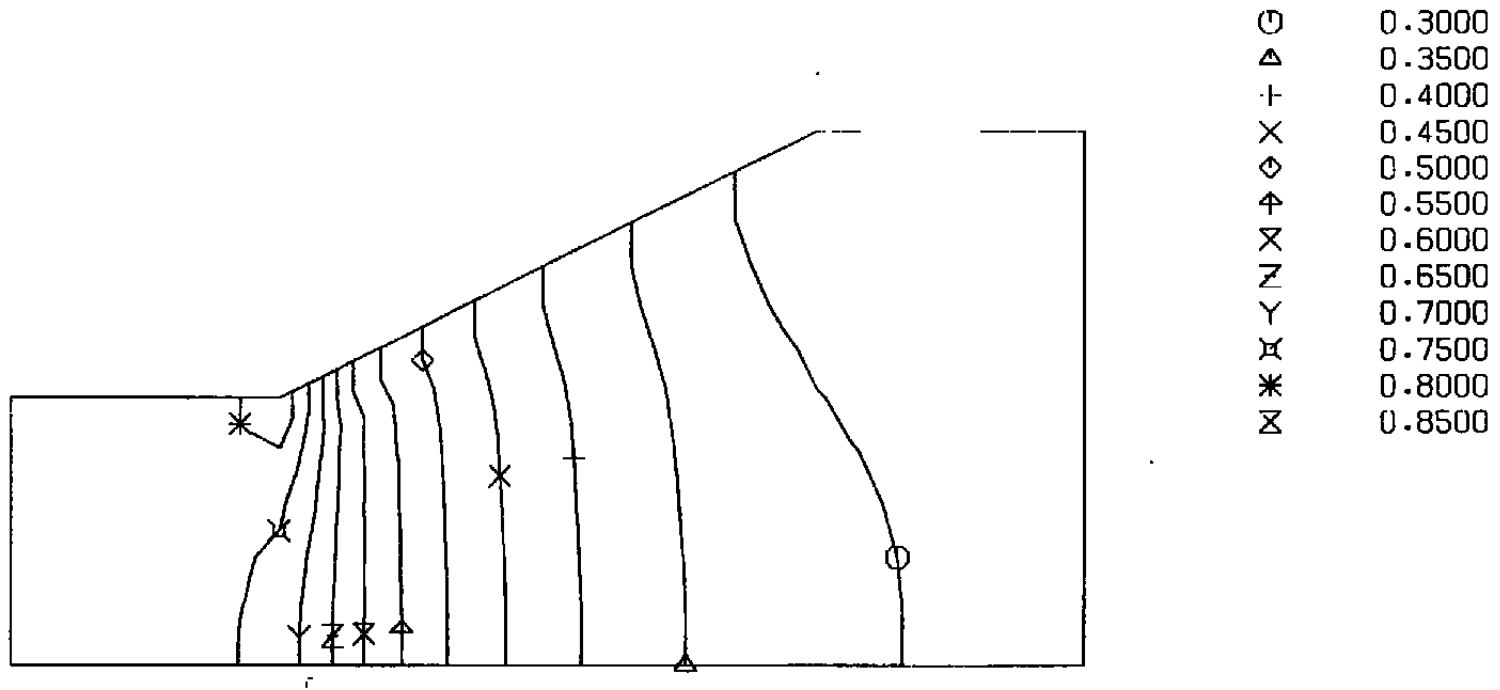

Figure E-3. Mach contours for diverging nozzle (2-D).

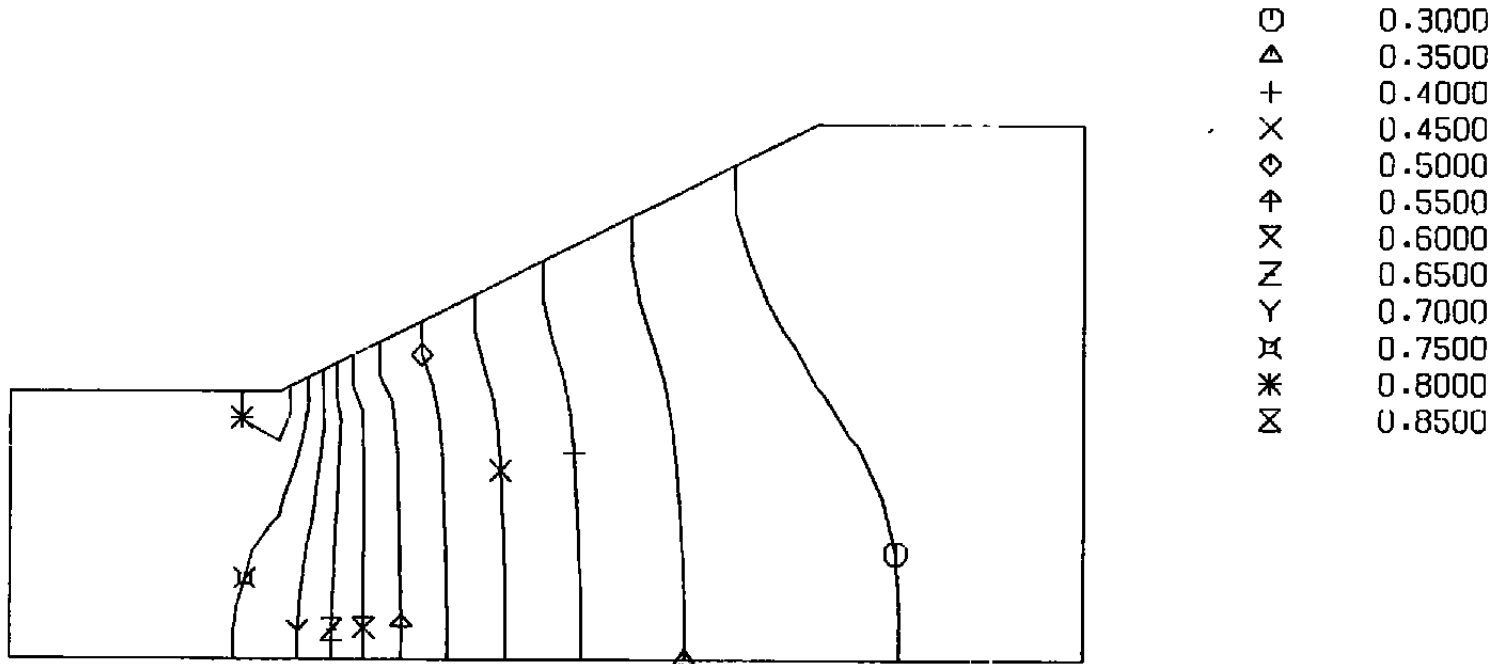

Figure E-4. Mach contours for diverging nozzle (3-D).

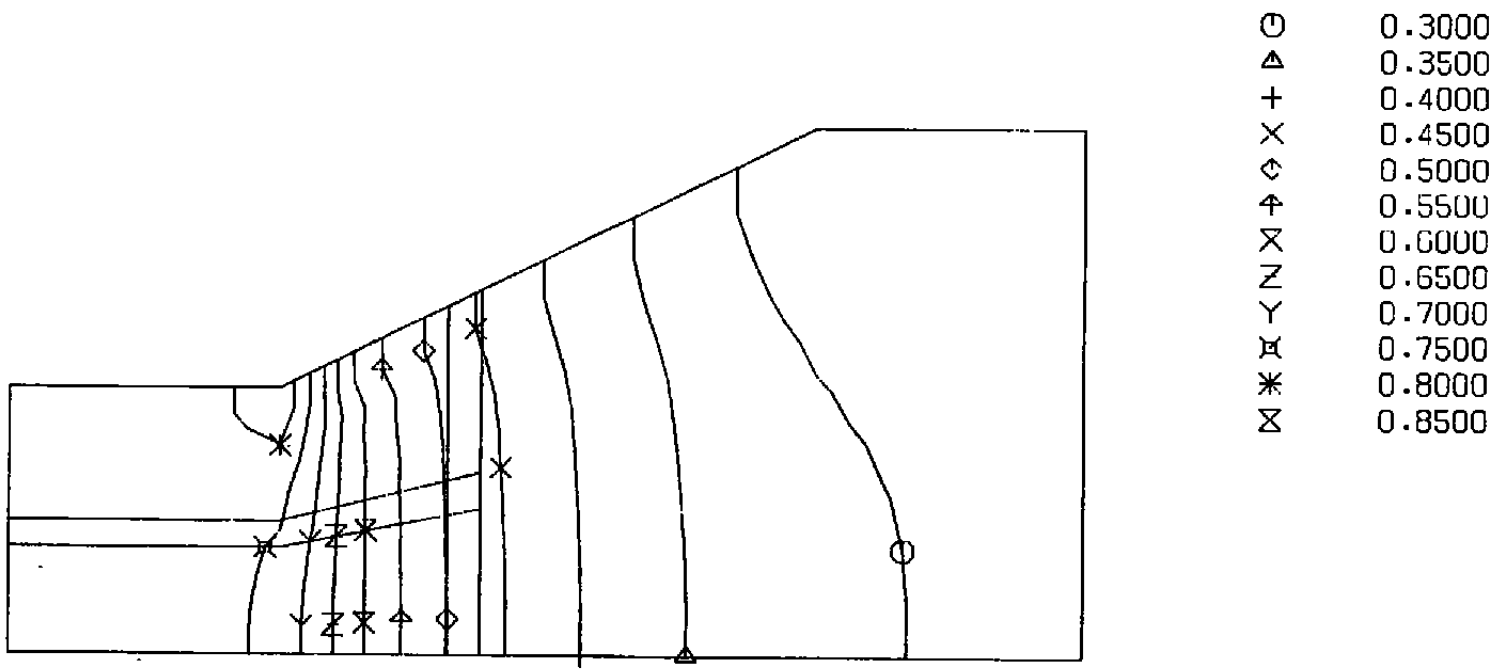

Figure E-5. Grid and Mach contours for contiguous blocks.

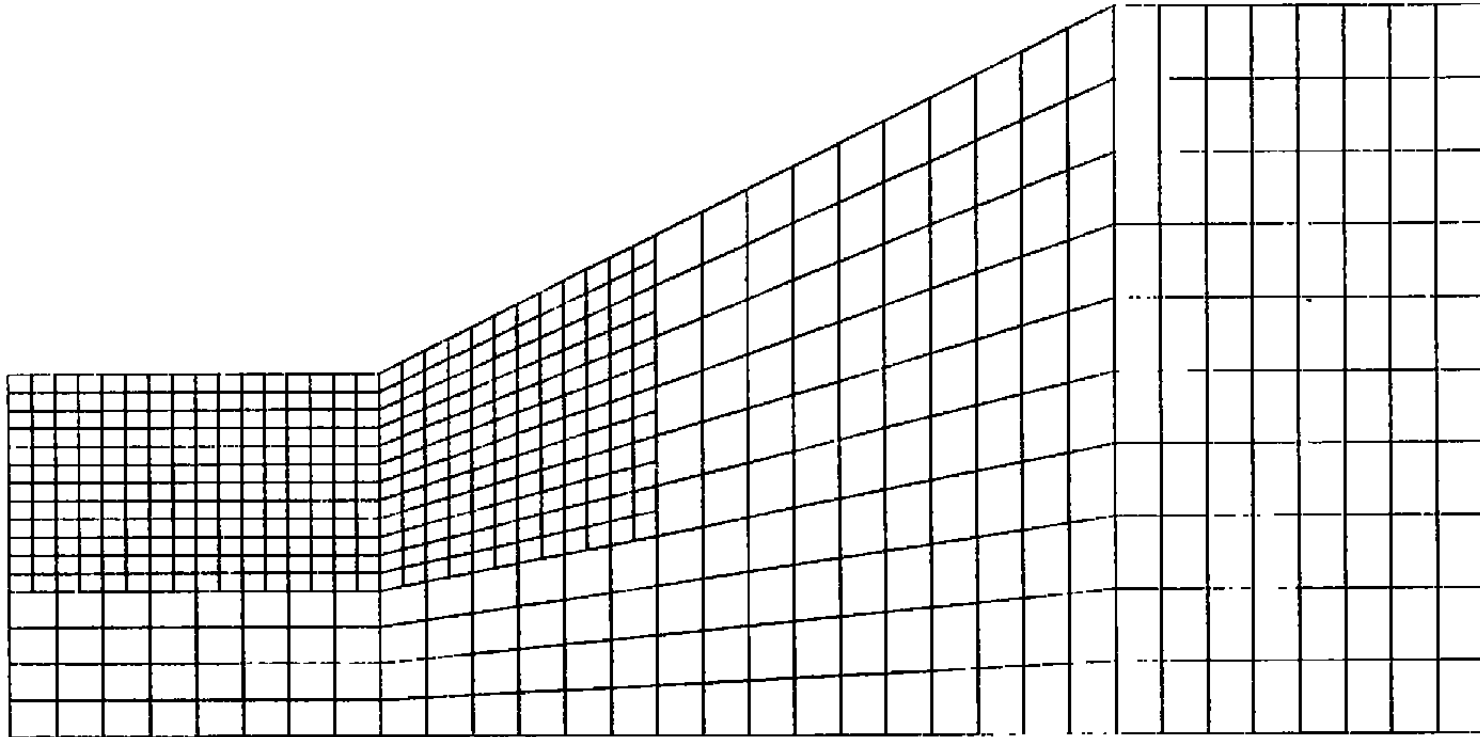

Figure E-6. Grid for noncontiguous blocks.

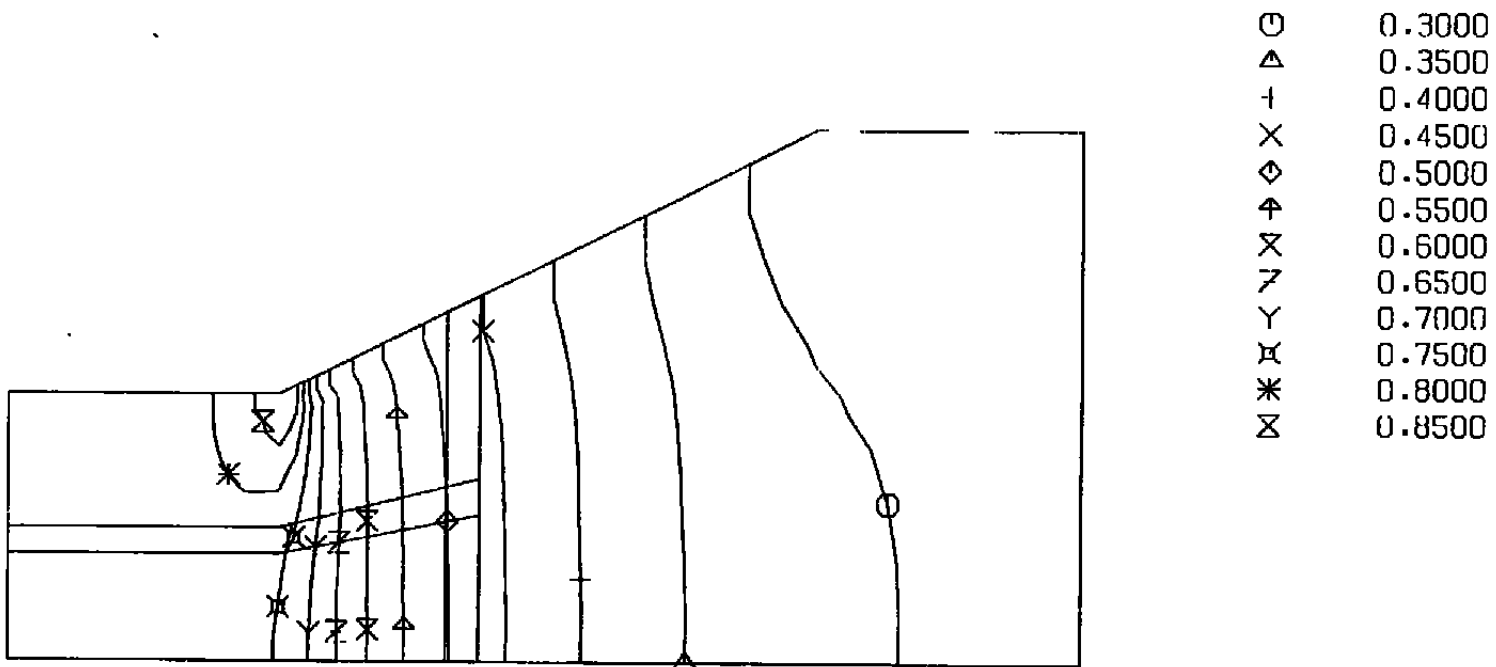

Figure E-7. Mach contours for noncontiguous blocks.

Listing E-1. Grid and Initial Condition Generator (2-D)

```

1  1.  PROGRAM ICFILE
2  2.  PARAMETER(JD=33,KD=11)
3  3.  DIMENSION R(JD,KD),RU(JD,KD),RV(JD,KD),E(JD,KD)
4  4.  DIMENSION X(JD,KD),Y(JD,KD)
5  5.  DATA G/1.4/
6  6.  GM1=G-1.
7  7.  DELX=8./32
8  8.  C FORM THE 'X' GRID ARRAY
9  9.  DO 1 J=1,JD
10 10. DO 1 K=1,KD
11 11. IF(J.EQ.1) THEN
12 12. X(J,K)=0.
13 13. ELSE
14 14. X(J,K)=X(J-1,K)+DELX
15 15. ENDF
16 16. 1 CONTINUE
17 17. C FORM THE 'Y' GRID ARRAYS
18 18. DO 2 J=1,JD
19 19. IF(X(J,KD).LE.2.) YO=1.
20 20. IF(X(J,KD).GT.6.) YO=2.
21 21. IF((X(J,KD).GT.2.) .AND. (X(J,KD).LE.6.)) THEN
22 22. YO=1.+(X(J,KD)-2.)*0.25
23 23. ENDF
24 24. DELY=YO/(KD-1)
25 25. Y(J,1)=0.0
26 26. DO 2 K=2,KD
27 27. Y(J,K)=Y(J,K-1)+DELY
28 28. 2 CONTINUE
29 29. C FORM THE ARRAYS OF NON-DIMENSIONAL CONSERVATION VARIABLES
30 30. C CONSISTENT WITH A FREE-STREAM MACH NUMBER OF 0.29
31 31. FMACH=0.29
32 32. FACT=(1.+.2*FMACH**2)
33 33. PBAR=FACT**(-3.5)/G
34 34. DO 1000 J=1,JD
35 35. DO 2000 K=1,KD
36 36. R(J,K)=FACT**(-2.5)
37 37. RU(J,K)=R(J,K)*FMACH*SQRT(1./FACT)
38 38. RV(J,K)=0.
39 39. E(J,K)=PBAR/GM1+.5*(RU(J,K)**2)/R(J,K)
40 40. 2000 CONTINUE
41 41. 1000 CONTINUE
42 42. NCT=0
43 43. WRITE(20)NCT,G
44 44. WRITE(20)JD,KD
45 45. WRITE(20)X,Y
46 46. WRITE(20)R,RU,RV,E
47 47. STOP
48 48. END

```

Listing E-2. Execution and Input File (2-D)

```

//A05569X JOB (SVT,ATT00000,00,78904912),'DGN TODD EL2 CFD',
// CLASS=X,TIME=(,5),USER=A05569,PASSWORD=XXXXXXXX,MSGCLASS=Z,
// MSGLEVEL=1,PRTY=8,NOTIFY=A05569
/**
/*ROUTE PRINT RMT0
/*JOBPARM ROOM=5 2ND FLOOR DO BLDG 1099
/**
// EXEC CRAY
CRSUBMIT F(OSJOB) NOTIFY(A05569) DEST(RMT0) PRINT(3) HOLD
//OSJOB DD *
JOB,JN=A05569Y,T=150,MFL.
ACCOUNT,AC=78904910,US=A05569.
FETCH,DN=CODE,TEXT='DSN=A05569.BARC(BARC2D),DISP=SHR'.
CFT,I=CODE,L=0.
ACCESS,DN=BNCHLIB,PDN=BNCHLIB,ID=BNCHMRK,OWN=SYSTEM.
ACCESS,DM=FT02,PDN=ICCASE1.
LDR,LIB=BNCHLIB.
*SAVE,DM=FT04,PDN=RSCASE1.
DISPOSE,DM=FT04,DC=ST,DF=TR,TEXT='
'DSN=A05569.TRCASE1.REST,DISP=(,CATLG),'
'UNIT=DISK,SPACE=(CYL,(38),RLSE),'
'DCB=(RECFM=F,LRECL=4096,BLKSIZE=4096)'.
/EOF
$INPUTS
NMAX=2500, NP=2500,
PREF=15.0, TREFR=600.,
IFXPRT=1, NBLOCK=1,
DIS2=0.00, DIS4=0.30,
DTCAP= 7.0, PCQMAX=10.0,
NSPRT=50, IAXISY=0, STOPL2=1.E-20,
$
$BLOCK
NPSEQ=2,
INVISC(1)=0, INVISC(2)=0,
$
$SPTSEG
JKLPI(1,1,1)=1,33,4, JKLPI(1,2,1)=1,11,1, IPORD(1)=2,
JKLPI(1,1,2)=2,32,2, JKLPI(1,2,2)=2,10,2, IPORD(2)=1,
$
$BOUND$
NJSEG=2,
JLINE(1)=1,
JKLOW(1)=2, JKHIGH(1)=10, JTYPE(1)=0,
JSIGN(1)=1, PRESSJ(1)=0.7142857, TEMPJ(1)=1.0,
JLINE(2)=33,
JKLOW(2)=2, JKHIGH(2)=10, JTYPE(2)=0,
JSIGN(2)=-1, PRESSJ(2)=0.67285, TEMPJ(2)=1.0,
NKSEG=2,
KLINE(1)=1,
KJLOW(1)=1, KJHIGH(1)=33, KTYPE(1)=50,
KSIGN(1)=1,
KLINE(2)=11,
KJLOW(2)=1, KJHIGH(2)=33, KTYPE(2)=50,
KSIGN(2)=-1,
$
/EOJ

```

Listing E-3. Diverging Nozzle Output (2-D)

NAMelist INPUTS:

```

PREF = 0.150000E+02      IAXISY = 0
TREFR = 0.600000E+03     NBLOCK = 1
VRAT = -0.666667E+00     NMAX = 2500
TSUTH = 0.198600E+03     NC = 0
RE = 0.000000E+00       NSPRT = 50
PR = 0.720000E+00       NP = 2500
PRT = 0.900000E+00      IFXPRT = 1
DIS2 = 0.000000E+00     IFXPLT = 0
DIS4 = 0.300000E+00     L2PLOT = 0
DTCAP = 0.700000E+01    IPLOT = 0
PCQMAX = 0.100000E+02   LNODE = 1
SPLND = 0.100000E+01    MBORD = 1
SMCO = 0.000000E+00     NUMDT = 0
STOPLZ = 0.100000E-19   IVARDT = 2
STOPTR = 0.500000E+01   ISOLVE = 1
ALPHA = 0.000000E+00    IRHS = 1
XNACH = 0.000000E+00    IFILTR = 1
                                INUTR = 1
    
```

THE ORDER OF BLOCK PROCESSING FOLLOWS

```

1
FOR BLOCK 1
JMAX = 33  KMAX = 11
NM = 33  IJK = 363
    
```

```

NAMelist BLOCK FOR BLOCK 1
GAMMA = 0.140000E+01     INVISC = 0 0
COFMIX = 0.900000E-01    LAMIN = 0 0
DTBLK = 0.000000E+00     NPSEG = 2
                                NBCSEG = 0
    
```

```

NAMelist PRTSEG FOR BLOCK 1
                                JKLP I
                                J K
    JA  JB  JS  KA  KB  KS  IPORD
    1   1  33  4   1  11  1     2  1
    2   2  32  2   2  10  2     1  2
    
```

```

NAMelist BOUNDS FOR BLOCK 1
JSEG JLINE JKLOW JKHIGH JTYPE INTERJ JSIGN PRESSJ TEMPJ JTYPE
1 1 2 10 0 1 0.714286E+00 0.100000E+01 FREE
2 33 2 10 0 -1 0.672850E+00 0.100000E+01 FREE
KSEG KLINE KJLOW KJHIGH KTYPE INTERK KSIGN PRESSK TEMPK KTYPE
1 1 1 33 50 1 1
2 11 1 33 50 -1
                                SLIP
    
```

GRID PATCHES FOR BLOCK 1

```

J-PATCHES  MINIMUM  MAXIMUM
             J  K      J  K
    1       2  2      32 10

K-PATCHES  MINIMUM  MAXIMUM
             J  K      J  K
    1       2  2      32 10
    
```

Listing E-3. Continued

| COUNT | BLOCK | DT | L2 RESIDUAL | MASS FLUX | MOMENTUM FLUXES | | ENERGY FLUX | MAX PERCENT VARIATION | MAX LOCATION | |
|-------|-------|------------|-------------|-------------|-----------------|------------|-------------|-----------------------|--------------|----|
| | | | | | X | Y | | | J | K |
| 50 | 1 | 0.7000E+01 | 0.1390E-03 | -0.8920E-03 | 0.1785E-02 | 0.4515E-03 | -0.1014E-02 | 0.5374E+00 | 9 | 10 |
| 100 | 1 | 0.7000E+01 | 0.7193E-04 | -0.2493E-03 | 0.1374E-02 | 0.6880E-03 | -0.1939E-03 | 0.2210E+00 | 9 | 10 |
| 150 | 1 | 0.7000E+01 | 0.3326E-04 | -0.1736E-03 | 0.7987E-03 | 0.7615E-03 | -0.1334E-03 | 0.1542E+00 | 9 | 10 |
| 200 | 1 | 0.7000E+01 | 0.1862E-04 | -0.1244E-03 | 0.4839E-03 | 0.3584E-03 | -0.9795E-04 | 0.1175E+00 | 9 | 10 |
| 250 | 1 | 0.7000E+01 | 0.1234E-04 | -0.8704E-04 | 0.2976E-03 | 0.2141E-03 | -0.6958E-04 | 0.8523E-01 | 9 | 10 |
| 300 | 1 | 0.7000E+01 | 0.8281E-05 | -0.5935E-04 | 0.1885E-03 | 0.1325E-03 | -0.4761E-04 | 0.5976E-01 | 9 | 10 |
| 350 | 1 | 0.7000E+01 | 0.5603E-05 | -0.4037E-04 | 0.1210E-03 | 0.8238E-04 | -0.3254E-04 | 0.4134E-01 | 9 | 10 |
| 400 | 1 | 0.7000E+01 | 0.3775E-05 | -0.2726E-04 | 0.7865E-04 | 0.5269E-04 | -0.2203E-04 | 0.2824E-01 | 9 | 10 |
| 450 | 1 | 0.7000E+01 | 0.2539E-05 | -0.1836E-04 | 0.5157E-04 | 0.3406E-04 | -0.1486E-04 | 0.1916E-01 | 9 | 10 |
| 500 | 1 | 0.7000E+01 | 0.1704E-05 | -0.1233E-04 | 0.3402E-04 | 0.2226E-04 | -0.9994E-05 | 0.1293E-01 | 9 | 10 |
| 550 | 1 | 0.7000E+01 | 0.1142E-05 | -0.8267E-05 | 0.2254E-04 | 0.1465E-04 | -0.6707E-05 | 0.8697E-02 | 9 | 10 |
| 600 | 1 | 0.7000E+01 | 0.7650E-06 | -0.5538E-05 | 0.1497E-04 | 0.9687E-05 | -0.4495E-05 | 0.5838E-02 | 9 | 10 |
| 650 | 1 | 0.7000E+01 | 0.5120E-06 | -0.3707E-05 | 0.9968E-05 | 0.6429E-05 | -0.3010E-05 | 0.3913E-02 | 9 | 10 |
| 700 | 1 | 0.7000E+01 | 0.3425E-06 | -0.2480E-05 | 0.6644E-05 | 0.4277E-05 | -0.2014E-05 | 0.2621E-02 | 9 | 10 |
| 750 | 1 | 0.7000E+01 | 0.2291E-06 | -0.1659E-05 | 0.4433E-05 | 0.2850E-05 | -0.1348E-05 | 0.1754E-02 | 9 | 10 |
| 800 | 1 | 0.7000E+01 | 0.1532E-06 | -0.1109E-05 | 0.2960E-05 | 0.1901E-05 | -0.9012E-06 | 0.1173E-02 | 9 | 10 |
| 850 | 1 | 0.7000E+01 | 0.1024E-06 | -0.7417E-06 | 0.1977E-05 | 0.1269E-05 | -0.6026E-06 | 0.7847E-03 | 9 | 10 |
| 900 | 1 | 0.7000E+01 | 0.6847E-07 | -0.4958E-06 | 0.1320E-05 | 0.8471E-06 | -0.4029E-06 | 0.5247E-03 | 9 | 10 |
| 950 | 1 | 0.7000E+01 | 0.4577E-07 | -0.3315E-06 | 0.8823E-06 | 0.5658E-06 | -0.2693E-06 | 0.3508E-03 | 9 | 10 |
| 1000 | 1 | 0.7000E+01 | 0.3060E-07 | -0.2216E-06 | 0.5896E-06 | 0.3780E-06 | -0.1801E-06 | 0.2345E-03 | 9 | 10 |
| 1050 | 1 | 0.7000E+01 | 0.2045E-07 | -0.1481E-06 | 0.3940E-06 | 0.2526E-06 | -0.1204E-06 | 0.1568E-03 | 9 | 10 |
| 1100 | 1 | 0.7000E+01 | 0.1367E-07 | -0.9900E-07 | 0.2633E-06 | 0.1688E-06 | -0.8045E-07 | 0.1048E-03 | 9 | 10 |
| 1150 | 1 | 0.7000E+01 | 0.9138E-08 | -0.6618E-07 | 0.1760E-06 | 0.1128E-06 | -0.5378E-07 | 0.7005E-04 | 9 | 10 |
| 1200 | 1 | 0.7000E+01 | 0.6108E-08 | -0.4423E-07 | 0.1176E-06 | 0.7541E-07 | -0.3595E-07 | 0.4683E-04 | 9 | 10 |
| 1250 | 1 | 0.7000E+01 | 0.4083E-08 | -0.2957E-07 | 0.7863E-07 | 0.5040E-07 | -0.2403E-07 | 0.3130E-04 | 9 | 10 |
| 1300 | 1 | 0.7000E+01 | 0.2729E-08 | -0.1976E-07 | 0.5256E-07 | 0.3369E-07 | -0.1606E-07 | 0.2092E-04 | 9 | 10 |
| 1350 | 1 | 0.7000E+01 | 0.1824E-08 | -0.1321E-07 | 0.3513E-07 | 0.2252E-07 | -0.1073E-07 | 0.1398E-04 | 9 | 10 |
| 1400 | 1 | 0.7000E+01 | 0.1219E-08 | -0.8830E-08 | 0.2348E-07 | 0.1505E-07 | -0.7175E-08 | 0.9347E-05 | 9 | 10 |
| 1450 | 1 | 0.7000E+01 | 0.8150E-09 | -0.5902E-08 | 0.1569E-07 | 0.1006E-07 | -0.4796E-08 | 0.6248E-05 | 9 | 10 |
| 1500 | 1 | 0.7000E+01 | 0.5447E-09 | -0.3945E-08 | 0.1049E-07 | 0.6724E-08 | -0.3206E-08 | 0.4176E-05 | 9 | 10 |
| 1550 | 1 | 0.7000E+01 | 0.3641E-09 | -0.2637E-08 | 0.7012E-08 | 0.4494E-08 | -0.2143E-08 | 0.2791E-05 | 9 | 10 |
| 1600 | 1 | 0.7000E+01 | 0.2434E-09 | -0.1763E-08 | 0.4687E-08 | 0.3004E-08 | -0.1432E-08 | 0.1866E-05 | 9 | 10 |
| 1650 | 1 | 0.7000E+01 | 0.1627E-09 | -0.1178E-08 | 0.3133E-08 | 0.2008E-08 | -0.9573E-09 | 0.1247E-05 | 9 | 10 |
| 1700 | 1 | 0.7000E+01 | 0.1087E-09 | -0.7874E-09 | 0.2094E-08 | 0.1342E-08 | -0.6399E-09 | 0.8336E-06 | 9 | 10 |
| 1750 | 1 | 0.7000E+01 | 0.7268E-10 | -0.5263E-09 | 0.1400E-08 | 0.8970E-09 | -0.4277E-09 | 0.5572E-06 | 9 | 10 |
| 1800 | 1 | 0.7000E+01 | 0.4858E-10 | -0.3518E-09 | 0.9355E-09 | 0.5996E-09 | -0.2859E-09 | 0.3724E-06 | 9 | 10 |
| 1850 | 1 | 0.7000E+01 | 0.3247E-10 | -0.2352E-09 | 0.6253E-09 | 0.4008E-09 | -0.1911E-09 | 0.2489E-06 | 9 | 10 |
| 1900 | 1 | 0.7000E+01 | 0.2170E-10 | -0.1572E-09 | 0.4180E-09 | 0.2679E-09 | -0.1277E-09 | 0.1664E-06 | 9 | 10 |
| 1950 | 1 | 0.7000E+01 | 0.1451E-10 | -0.1051E-09 | 0.2794E-09 | 0.1791E-09 | -0.8538E-10 | 0.1112E-06 | 9 | 10 |
| 2000 | 1 | 0.7000E+01 | 0.9697E-11 | -0.7023E-10 | 0.1867E-09 | 0.1197E-09 | -0.5707E-10 | 0.7434E-07 | 9 | 10 |
| 2050 | 1 | 0.7000E+01 | 0.6482E-11 | -0.4694E-10 | 0.1248E-09 | 0.8001E-10 | -0.3815E-10 | 0.4969E-07 | 9 | 10 |
| 2100 | 1 | 0.7000E+01 | 0.4333E-11 | -0.3138E-10 | 0.8343E-10 | 0.5341E-10 | -0.2550E-10 | 0.3321E-07 | 9 | 10 |
| 2150 | 1 | 0.7000E+01 | 0.2896E-11 | -0.2097E-10 | 0.5577E-10 | 0.3572E-10 | -0.1704E-10 | 0.2220E-07 | 9 | 10 |
| 2200 | 1 | 0.7000E+01 | 0.1936E-11 | -0.1402E-10 | 0.3728E-10 | 0.2390E-10 | -0.1139E-10 | 0.1483E-07 | 9 | 10 |
| 2250 | 1 | 0.7000E+01 | 0.1294E-11 | -0.9372E-11 | 0.2492E-10 | 0.1602E-10 | -0.7615E-11 | 0.9916E-08 | 9 | 10 |
| 2300 | 1 | 0.7000E+01 | 0.8649E-12 | -0.6266E-11 | 0.1665E-10 | 0.1071E-10 | -0.5091E-11 | 0.6625E-08 | 9 | 10 |
| 2350 | 1 | 0.7000E+01 | 0.5783E-12 | -0.4187E-11 | 0.1116E-10 | 0.7153E-11 | -0.3400E-11 | 0.4431E-08 | 9 | 10 |
| 2400 | 1 | 0.7000E+01 | 0.3865E-12 | -0.2801E-11 | 0.7443E-11 | 0.4753E-11 | -0.2275E-11 | 0.2962E-08 | 9 | 10 |
| 2450 | 1 | 0.7000E+01 | 0.2584E-12 | -0.1873E-11 | 0.4976E-11 | 0.3201E-11 | -0.1521E-11 | 0.1979E-08 | 9 | 10 |
| 2500 | 1 | 0.7000E+01 | 0.1728E-12 | -0.1253E-11 | 0.3326E-11 | 0.2178E-11 | -0.1017E-11 | 0.1325E-08 | 9 | 10 |

Listing E-3. Continued

| BLOCK 1 VARIABLES AT J = 1 | | | | ITERATION NUMBER: | | 2500 | | |
|----------------------------|------------|-------------|-------------|-------------------|------------|------------|------------|------------|
| K | PRESSURE | TEMPERATURE | MACH NUMBER | TOTAL PRESS | U-COSINE | V-COSINE | X | Y |
| 1 | 0.1016E+02 | 0.5368E+03 | 0.7670E+00 | 0.1500E+02 | 0.1000E+01 | 0.0000E+00 | 0.0000E+00 | 0.0000E+00 |
| 2 | 0.1016E+02 | 0.5368E+03 | 0.7670E+00 | 0.1500E+02 | 0.1000E+01 | 0.0000E+00 | 0.0000E+00 | 0.1000E+00 |
| 3 | 0.1016E+02 | 0.5368E+03 | 0.7670E+00 | 0.1500E+02 | 0.1000E+01 | 0.0000E+00 | 0.0000E+00 | 0.2000E+00 |
| 4 | 0.1016E+02 | 0.5368E+03 | 0.7670E+00 | 0.1500E+02 | 0.1000E+01 | 0.0000E+00 | 0.0000E+00 | 0.3000E+00 |
| 5 | 0.1016E+02 | 0.5368E+03 | 0.7671E+00 | 0.1500E+02 | 0.1000E+01 | 0.0000E+00 | 0.0000E+00 | 0.4000E+00 |
| 6 | 0.1016E+02 | 0.5368E+03 | 0.7671E+00 | 0.1500E+02 | 0.1000E+01 | 0.0000E+00 | 0.0000E+00 | 0.5000E+00 |
| 7 | 0.1016E+02 | 0.5368E+03 | 0.7671E+00 | 0.1500E+02 | 0.1000E+01 | 0.0000E+00 | 0.0000E+00 | 0.6000E+00 |
| 8 | 0.1016E+02 | 0.5368E+03 | 0.7672E+00 | 0.1500E+02 | 0.1000E+01 | 0.0000E+00 | 0.0000E+00 | 0.7000E+00 |
| 9 | 0.1016E+02 | 0.5368E+03 | 0.7672E+00 | 0.1500E+02 | 0.1000E+01 | 0.0000E+00 | 0.0000E+00 | 0.8000E+00 |
| 10 | 0.1016E+02 | 0.5368E+03 | 0.7672E+00 | 0.1500E+02 | 0.1000E+01 | 0.0000E+00 | 0.0000E+00 | 0.9000E+00 |
| 11 | 0.1016E+02 | 0.5368E+03 | 0.7672E+00 | 0.1500E+02 | 0.1000E+01 | 0.0000E+00 | 0.0000E+00 | 0.1000E+01 |

| BLOCK 1 VARIABLES AT J = 5 | | | | ITERATION NUMBER: | | 2500 | | |
|----------------------------|------------|-------------|-------------|-------------------|------------|------------|------------|------------|
| K | PRESSURE | TEMPERATURE | MACH NUMBER | TOTAL PRESS | U-COSINE | V-COSINE | X | Y |
| 1 | 0.1017E+02 | 0.5370E+03 | 0.7662E+00 | 0.1500E+02 | 0.1000E+01 | 0.0000E+00 | 0.1000E+01 | 0.0000E+00 |
| 2 | 0.1017E+02 | 0.5370E+03 | 0.7662E+00 | 0.1500E+02 | 0.1000E+01 | 0.2698E-03 | 0.1000E+01 | 0.1000E+00 |
| 3 | 0.1017E+02 | 0.5369E+03 | 0.7663E+00 | 0.1500E+02 | 0.1000E+01 | 0.5852E-03 | 0.1000E+01 | 0.2000E+00 |
| 4 | 0.1017E+02 | 0.5369E+03 | 0.7665E+00 | 0.1500E+02 | 0.1000E+01 | 0.8151E-03 | 0.1000E+01 | 0.3000E+00 |
| 5 | 0.1016E+02 | 0.5368E+03 | 0.7667E+00 | 0.1500E+02 | 0.1000E+01 | 0.1012E-02 | 0.1000E+01 | 0.4000E+00 |
| 6 | 0.1016E+02 | 0.5368E+03 | 0.7670E+00 | 0.1499E+02 | 0.1000E+01 | 0.1108E-02 | 0.1000E+01 | 0.5000E+00 |
| 7 | 0.1016E+02 | 0.5367E+03 | 0.7672E+00 | 0.1499E+02 | 0.1000E+01 | 0.1110E-02 | 0.1000E+01 | 0.6000E+00 |
| 8 | 0.1015E+02 | 0.5367E+03 | 0.7674E+00 | 0.1499E+02 | 0.1000E+01 | 0.1002E-02 | 0.1000E+01 | 0.7000E+00 |
| 9 | 0.1015E+02 | 0.5366E+03 | 0.7675E+00 | 0.1499E+02 | 0.1000E+01 | 0.7610E-03 | 0.1000E+01 | 0.8000E+00 |
| 10 | 0.1015E+02 | 0.5366E+03 | 0.7677E+00 | 0.1499E+02 | 0.1000E+01 | 0.3442E-03 | 0.1000E+01 | 0.9000E+00 |
| 11 | 0.1015E+02 | 0.5366E+03 | 0.7677E+00 | 0.1499E+02 | 0.1000E+01 | 0.0000E+00 | 0.1000E+01 | 0.1000E+01 |

| BLOCK 1 VARIABLES AT J = 9 | | | | ITERATION NUMBER: | | 2500 | | |
|----------------------------|------------|-------------|-------------|-------------------|------------|------------|------------|------------|
| K | PRESSURE | TEMPERATURE | MACH NUMBER | TOTAL PRESS | U-COSINE | V-COSINE | X | Y |
| 1 | 0.1060E+02 | 0.5433E+03 | 0.7239E+00 | 0.1502E+02 | 0.1000E+01 | 0.8059E-16 | 0.2000E+01 | 0.0000E+00 |
| 2 | 0.1060E+02 | 0.5433E+03 | 0.7239E+00 | 0.1502E+02 | 0.1000E+01 | 0.6843E-02 | 0.2000E+01 | 0.1000E+00 |
| 3 | 0.1058E+02 | 0.5429E+03 | 0.7262E+00 | 0.1502E+02 | 0.9998E+00 | 0.1745E-01 | 0.2000E+01 | 0.2000E+00 |
| 4 | 0.1052E+02 | 0.5421E+03 | 0.7318E+00 | 0.1502E+02 | 0.9997E+00 | 0.2414E-01 | 0.2000E+01 | 0.3000E+00 |
| 5 | 0.1048E+02 | 0.5415E+03 | 0.7372E+00 | 0.1504E+02 | 0.9994E+00 | 0.3582E-01 | 0.2000E+01 | 0.4000E+00 |
| 6 | 0.1035E+02 | 0.5395E+03 | 0.7496E+00 | 0.1503E+02 | 0.9992E+00 | 0.4081E-01 | 0.2000E+01 | 0.5000E+00 |
| 7 | 0.1031E+02 | 0.5387E+03 | 0.7586E+00 | 0.1509E+02 | 0.9984E+00 | 0.5643E-01 | 0.2000E+01 | 0.6000E+00 |
| 8 | 0.1004E+02 | 0.5346E+03 | 0.7815E+00 | 0.1503E+02 | 0.9984E+00 | 0.5722E-01 | 0.2000E+01 | 0.7000E+00 |
| 9 | 0.1001E+02 | 0.5338E+03 | 0.7963E+00 | 0.1520E+02 | 0.9965E+00 | 0.8304E-01 | 0.2000E+01 | 0.8000E+00 |
| 10 | 0.9495E+01 | 0.5258E+03 | 0.8367E+00 | 0.1502E+02 | 0.9973E+00 | 0.7345E-01 | 0.2000E+01 | 0.9000E+00 |
| 11 | 0.9507E+01 | 0.5260E+03 | 0.8355E+00 | 0.1502E+02 | 0.9923E+00 | 0.1240E+00 | 0.2000E+01 | 0.1000E+01 |

| BLOCK 1 VARIABLES AT J = 13 | | | | ITERATION NUMBER: | | 2500 | | |
|-----------------------------|------------|-------------|-------------|-------------------|------------|------------|------------|------------|
| K | PRESSURE | TEMPERATURE | MACH NUMBER | TOTAL PRESS | U-COSINE | V-COSINE | X | Y |
| 1 | 0.1235E+02 | 0.5677E+03 | 0.5338E+00 | 0.1499E+02 | 0.1000E+01 | 0.2138E-15 | 0.3000E+01 | 0.0000E+00 |
| 2 | 0.1235E+02 | 0.5677E+03 | 0.5340E+00 | 0.1499E+02 | 0.9997E+00 | 0.2291E-01 | 0.3000E+01 | 0.1250E+00 |
| 3 | 0.1235E+02 | 0.5677E+03 | 0.5336E+00 | 0.1499E+02 | 0.9989E+00 | 0.4766E-01 | 0.3000E+01 | 0.2500E+00 |
| 4 | 0.1235E+02 | 0.5678E+03 | 0.5328E+00 | 0.1499E+02 | 0.9975E+00 | 0.7087E-01 | 0.3000E+01 | 0.3750E+00 |
| 5 | 0.1236E+02 | 0.5679E+03 | 0.5322E+00 | 0.1499E+02 | 0.9954E+00 | 0.9579E-01 | 0.3000E+01 | 0.5000E+00 |
| 6 | 0.1237E+02 | 0.5681E+03 | 0.5298E+00 | 0.1498E+02 | 0.9928E+00 | 0.1201E+00 | 0.3000E+01 | 0.6250E+00 |
| 7 | 0.1238E+02 | 0.5682E+03 | 0.5295E+00 | 0.1499E+02 | 0.9895E+00 | 0.1445E+00 | 0.3000E+01 | 0.7500E+00 |
| 8 | 0.1241E+02 | 0.5687E+03 | 0.5259E+00 | 0.1498E+02 | 0.9854E+00 | 0.1704E+00 | 0.3000E+01 | 0.8750E+00 |
| 9 | 0.1242E+02 | 0.5690E+03 | 0.5217E+00 | 0.1495E+02 | 0.9811E+00 | 0.1936E+00 | 0.3000E+01 | 0.1000E+01 |
| 10 | 0.1247E+02 | 0.5700E+03 | 0.5080E+00 | 0.1487E+02 | 0.9744E+00 | 0.2248E+00 | 0.3000E+01 | 0.1125E+01 |
| 11 | 0.1247E+02 | 0.5700E+03 | 0.5079E+00 | 0.1487E+02 | 0.9701E+00 | 0.2625E+00 | 0.3000E+01 | 0.1250E+01 |

Listing E-3. Continued

| BLOCK 1 VARIABLES AT J = 17 | | | | ITERATION NUMBER: | | 2500 | | |
|-----------------------------|------------|-------------|-------------|-------------------|------------|------------|------------|------------|
| K | PRESSURE | TEMPERATURE | MACH NUMBER | TOTAL PRESS | U-COSINE | V-COSINE | X | Y |
| 1 | 0.1328E+02 | 0.5796E+03 | 0.4195E+00 | 0.1499E+02 | 0.1000E+01 | 0.0000E+00 | 0.4000E+01 | 0.0000E+00 |
| 2 | 0.1328E+02 | 0.5796E+03 | 0.4197E+00 | 0.1499E+02 | 0.9997E+00 | 0.2547E-01 | 0.4000E+01 | 0.1500E+00 |
| 3 | 0.1329E+02 | 0.5797E+03 | 0.4190E+00 | 0.1499E+02 | 0.9988E+00 | 0.4904E-01 | 0.4000E+01 | 0.3000E+00 |
| 4 | 0.1329E+02 | 0.5798E+03 | 0.4179E+00 | 0.1499E+02 | 0.9972E+00 | 0.7433E-01 | 0.4000E+01 | 0.4500E+00 |
| 5 | 0.1330E+02 | 0.5799E+03 | 0.4165E+00 | 0.1499E+02 | 0.9952E+00 | 0.9783E-01 | 0.4000E+01 | 0.6000E+00 |
| 6 | 0.1332E+02 | 0.5801E+03 | 0.4149E+00 | 0.1499E+02 | 0.9924E+00 | 0.1232E+00 | 0.4000E+01 | 0.7500E+00 |
| 7 | 0.1332E+02 | 0.5802E+03 | 0.4132E+00 | 0.1499E+02 | 0.9893E+00 | 0.1460E+00 | 0.4000E+01 | 0.9000E+00 |
| 8 | 0.1335E+02 | 0.5807E+03 | 0.4090E+00 | 0.1498E+02 | 0.9850E+00 | 0.1723E+00 | 0.4000E+01 | 0.1050E+01 |
| 9 | 0.1336E+02 | 0.5810E+03 | 0.4021E+00 | 0.1493E+02 | 0.9808E+00 | 0.1953E+00 | 0.4000E+01 | 0.1200E+01 |
| 10 | 0.1340E+02 | 0.5817E+03 | 0.3959E+00 | 0.1492E+02 | 0.9749E+00 | 0.2227E+00 | 0.4000E+01 | 0.1350E+01 |
| 11 | 0.1340E+02 | 0.5817E+03 | 0.3958E+00 | 0.1492E+02 | 0.9701E+00 | 0.2425E+00 | 0.4000E+01 | 0.1500E+01 |

| BLOCK 1 VARIABLES AT J = 21 | | | | ITERATION NUMBER: | | 2500 | | |
|-----------------------------|------------|-------------|-------------|-------------------|------------|------------|------------|------------|
| K | PRESSURE | TEMPERATURE | MACH NUMBER | TOTAL PRESS | U-COSINE | V-COSINE | X | Y |
| 1 | 0.1377E+02 | 0.5856E+03 | 0.3511E+00 | 0.1499E+02 | 0.1000E+01 | 0.0000E+00 | 0.5000E+01 | 0.0000E+00 |
| 2 | 0.1376E+02 | 0.5856E+03 | 0.3512E+00 | 0.1499E+02 | 0.9997E+00 | 0.2347E-01 | 0.5000E+01 | 0.1750E+00 |
| 3 | 0.1377E+02 | 0.5856E+03 | 0.3506E+00 | 0.1499E+02 | 0.9990E+00 | 0.4494E-01 | 0.5000E+01 | 0.3500E+00 |
| 4 | 0.1378E+02 | 0.5858E+03 | 0.3492E+00 | 0.1499E+02 | 0.9977E+00 | 0.6843E-01 | 0.5000E+01 | 0.5250E+00 |
| 5 | 0.1379E+02 | 0.5859E+03 | 0.3476E+00 | 0.1499E+02 | 0.9959E+00 | 0.9007E-01 | 0.5000E+01 | 0.7000E+00 |
| 6 | 0.1381E+02 | 0.5861E+03 | 0.3455E+00 | 0.1500E+02 | 0.9935E+00 | 0.1142E+00 | 0.5000E+01 | 0.8750E+00 |
| 7 | 0.1382E+02 | 0.5863E+03 | 0.3424E+00 | 0.1498E+02 | 0.9906E+00 | 0.1366E+00 | 0.5000E+01 | 0.1050E+01 |
| 8 | 0.1385E+02 | 0.5868E+03 | 0.3366E+00 | 0.1498E+02 | 0.9866E+00 | 0.1632E+00 | 0.5000E+01 | 0.1225E+01 |
| 9 | 0.1385E+02 | 0.5871E+03 | 0.3300E+00 | 0.1494E+02 | 0.9822E+00 | 0.1878E+00 | 0.5000E+01 | 0.1400E+01 |
| 10 | 0.1389E+02 | 0.5877E+03 | 0.3250E+00 | 0.1494E+02 | 0.9762E+00 | 0.2170E+00 | 0.5000E+01 | 0.1575E+01 |
| 11 | 0.1389E+02 | 0.5877E+03 | 0.3249E+00 | 0.1494E+02 | 0.9701E+00 | 0.2425E+00 | 0.5000E+01 | 0.1750E+01 |

| BLOCK 1 VARIABLES AT J = 25 | | | | ITERATION NUMBER: | | 2500 | | |
|-----------------------------|------------|-------------|-------------|-------------------|------------|------------|------------|------------|
| K | PRESSURE | TEMPERATURE | MACH NUMBER | TOTAL PRESS | U-COSINE | V-COSINE | X | Y |
| 1 | 0.1401E+02 | 0.5886E+03 | 0.3116E+00 | 0.1499E+02 | 0.1000E+01 | 0.0000E+00 | 0.6000E+01 | 0.0000E+00 |
| 2 | 0.1401E+02 | 0.5885E+03 | 0.3116E+00 | 0.1499E+02 | 0.9999E+00 | 0.1619E-01 | 0.6000E+01 | 0.2000E+00 |
| 3 | 0.1402E+02 | 0.5886E+03 | 0.3107E+00 | 0.1499E+02 | 0.9996E+00 | 0.2952E-01 | 0.6000E+01 | 0.4000E+00 |
| 4 | 0.1403E+02 | 0.5888E+03 | 0.3086E+00 | 0.1499E+02 | 0.9990E+00 | 0.4536E-01 | 0.6000E+01 | 0.6000E+00 |
| 5 | 0.1405E+02 | 0.5890E+03 | 0.3058E+00 | 0.1499E+02 | 0.9983E+00 | 0.5791E-01 | 0.6000E+01 | 0.8000E+00 |
| 6 | 0.1408E+02 | 0.5894E+03 | 0.3011E+00 | 0.1499E+02 | 0.9972E+00 | 0.7449E-01 | 0.6000E+01 | 0.1000E+01 |
| 7 | 0.1410E+02 | 0.5897E+03 | 0.2943E+00 | 0.1497E+02 | 0.9963E+00 | 0.8556E-01 | 0.6000E+01 | 0.1200E+01 |
| 8 | 0.1416E+02 | 0.5906E+03 | 0.2831E+00 | 0.1497E+02 | 0.9944E+00 | 0.1058E+00 | 0.6000E+01 | 0.1400E+01 |
| 9 | 0.1417E+02 | 0.5909E+03 | 0.2702E+00 | 0.1491E+02 | 0.9936E+00 | 0.1127E+00 | 0.6000E+01 | 0.1600E+01 |
| 10 | 0.1431E+02 | 0.5926E+03 | 0.2546E+00 | 0.1497E+02 | 0.9894E+00 | 0.1455E+00 | 0.6000E+01 | 0.1800E+01 |
| 11 | 0.1431E+02 | 0.5926E+03 | 0.2545E+00 | 0.1497E+02 | 0.9923E+00 | 0.1240E+00 | 0.6000E+01 | 0.2000E+01 |

| BLOCK 1 VARIABLES AT J = 29 | | | | ITERATION NUMBER: | | 2500 | | |
|-----------------------------|------------|-------------|-------------|-------------------|------------|------------|------------|------------|
| K | PRESSURE | TEMPERATURE | MACH NUMBER | TOTAL PRESS | U-COSINE | V-COSINE | X | Y |
| 1 | 0.1410E+02 | 0.5896E+03 | 0.2965E+00 | 0.1499E+02 | 0.1000E+01 | 0.0000E+00 | 0.7000E+01 | 0.0000E+00 |
| 2 | 0.1410E+02 | 0.5896E+03 | 0.2965E+00 | 0.1499E+02 | 0.1000E+01 | 0.5747E-02 | 0.7000E+01 | 0.2000E+00 |
| 3 | 0.1411E+02 | 0.5897E+03 | 0.2963E+00 | 0.1499E+02 | 0.1000E+01 | 0.9486E-02 | 0.7000E+01 | 0.4000E+00 |
| 4 | 0.1411E+02 | 0.5897E+03 | 0.2957E+00 | 0.1499E+02 | 0.9999E+00 | 0.1435E-01 | 0.7000E+01 | 0.6000E+00 |
| 5 | 0.1412E+02 | 0.5898E+03 | 0.2944E+00 | 0.1499E+02 | 0.9999E+00 | 0.1640E-01 | 0.7000E+01 | 0.8000E+00 |
| 6 | 0.1413E+02 | 0.5900E+03 | 0.2926E+00 | 0.1499E+02 | 0.9998E+00 | 0.1940E-01 | 0.7000E+01 | 0.1000E+01 |
| 7 | 0.1413E+02 | 0.5901E+03 | 0.2885E+00 | 0.1497E+02 | 0.9998E+00 | 0.1921E-01 | 0.7000E+01 | 0.1200E+01 |
| 8 | 0.1415E+02 | 0.5904E+03 | 0.2836E+00 | 0.1496E+02 | 0.9998E+00 | 0.1967E-01 | 0.7000E+01 | 0.1400E+01 |
| 9 | 0.1415E+02 | 0.5906E+03 | 0.2789E+00 | 0.1494E+02 | 0.9999E+00 | 0.1404E-01 | 0.7000E+01 | 0.1600E+01 |
| 10 | 0.1416E+02 | 0.5909E+03 | 0.2799E+00 | 0.1496E+02 | 0.1000E+01 | 0.5770E-02 | 0.7000E+01 | 0.1800E+01 |
| 11 | 0.1416E+02 | 0.5909E+03 | 0.2799E+00 | 0.1496E+02 | 0.1000E+01 | 0.0000E+00 | 0.7000E+01 | 0.2000E+01 |

Listing E-3. Continued

| BLOCK 1 VARIABLES AT J = 33 | | | | ITERATION NUMBER: 2500 | | | | |
|-----------------------------|------------|-------------|-------------|------------------------|------------|------------|------------|------------|
| K | PRESSURE | TEMPERATURE | MACH NUMBER | TOTAL PRESS | U-COSINE | V-COSINE | X | Y |
| 1 | 0.1413E+02 | 0.5901E+03 | 0.2925E+00 | 0.1499E+02 | 0.1000E+01 | 0.0000E+00 | 0.8000E+01 | 0.0000E+00 |
| 2 | 0.1413E+02 | 0.5901E+03 | 0.2925E+00 | 0.1499E+02 | 0.1000E+01 | 0.1948E-02 | 0.8000E+01 | 0.2000E+00 |
| 3 | 0.1413E+02 | 0.5901E+03 | 0.2927E+00 | 0.1500E+02 | 0.1000E+01 | 0.3211E-02 | 0.8000E+01 | 0.4000E+00 |
| 4 | 0.1413E+02 | 0.5900E+03 | 0.2929E+00 | 0.1500E+02 | 0.1000E+01 | 0.4713E-02 | 0.8000E+01 | 0.6000E+00 |
| 5 | 0.1413E+02 | 0.5900E+03 | 0.2927E+00 | 0.1500E+02 | 0.1000E+01 | 0.5266E-02 | 0.8000E+01 | 0.8000E+00 |
| 6 | 0.1413E+02 | 0.5900E+03 | 0.2917E+00 | 0.1499E+02 | 0.1000E+01 | 0.5926E-02 | 0.8000E+01 | 0.1000E+01 |
| 7 | 0.1413E+02 | 0.5900E+03 | 0.2891E+00 | 0.1497E+02 | 0.1000E+01 | 0.5844E-02 | 0.8000E+01 | 0.1200E+01 |
| 8 | 0.1413E+02 | 0.5901E+03 | 0.2862E+00 | 0.1496E+02 | 0.1000E+01 | 0.5173E-02 | 0.8000E+01 | 0.1400E+01 |
| 9 | 0.1413E+02 | 0.5902E+03 | 0.2842E+00 | 0.1494E+02 | 0.1000E+01 | 0.3320E-02 | 0.8000E+01 | 0.1600E+01 |
| 10 | 0.1413E+02 | 0.5902E+03 | 0.2843E+00 | 0.1495E+02 | 0.1000E+01 | 0.8518E-03 | 0.8000E+01 | 0.1800E+01 |
| 11 | 0.1413E+02 | 0.5902E+03 | 0.2843E+00 | 0.1495E+02 | 0.1000E+01 | 0.0000E+00 | 0.8000E+01 | 0.2000E+01 |

| BLOCK 1 VARIABLES AT K = 2 | | | | ITERATION NUMBER: 2500 | | | | |
|----------------------------|------------|-------------|-------------|------------------------|------------|-------------|------------|------------|
| J | PRESSURE | TEMPERATURE | MACH NUMBER | TOTAL PRESS | U-COSINE | V-COSINE | X | Y |
| 2 | 0.1016E+02 | 0.5369E+03 | 0.7671E+00 | 0.1500E+02 | 0.1000E+01 | -0.9109E-05 | 0.2500E+00 | 0.1000E+00 |
| 4 | 0.1017E+02 | 0.5369E+03 | 0.7668E+00 | 0.1501E+02 | 0.1000E+01 | 0.1836E-04 | 0.7500E+00 | 0.1000E+00 |
| 6 | 0.1020E+02 | 0.5373E+03 | 0.7641E+00 | 0.1501E+02 | 0.1000E+01 | 0.4317E-03 | 0.1250E+01 | 0.1000E+00 |
| 8 | 0.1036E+02 | 0.5398E+03 | 0.7469E+00 | 0.1500E+02 | 0.1000E+01 | 0.3428E-02 | 0.1750E+01 | 0.1000E+00 |
| 10 | 0.1098E+02 | 0.5489E+03 | 0.6815E+00 | 0.1498E+02 | 0.9999E+00 | 0.1280E-01 | 0.2250E+01 | 0.1062E+00 |
| 12 | 0.1199E+02 | 0.5630E+03 | 0.5745E+00 | 0.1500E+02 | 0.9998E+00 | 0.2065E-01 | 0.2750E+01 | 0.1187E+00 |
| 14 | 0.1265E+02 | 0.5716E+03 | 0.4990E+00 | 0.1499E+02 | 0.9997E+00 | 0.2433E-01 | 0.3250E+01 | 0.1312E+00 |
| 16 | 0.1310E+02 | 0.5774E+03 | 0.4426E+00 | 0.1499E+02 | 0.9997E+00 | 0.2545E-01 | 0.3750E+01 | 0.1437E+00 |
| 18 | 0.1343E+02 | 0.5815E+03 | 0.3993E+00 | 0.1499E+02 | 0.9997E+00 | 0.2532E-01 | 0.4250E+01 | 0.1562E+00 |
| 20 | 0.1367E+02 | 0.5844E+03 | 0.3654E+00 | 0.1499E+02 | 0.9997E+00 | 0.2438E-01 | 0.4750E+01 | 0.1687E+00 |
| 22 | 0.1384E+02 | 0.5865E+03 | 0.3389E+00 | 0.1499E+02 | 0.9997E+00 | 0.2238E-01 | 0.5250E+01 | 0.1812E+00 |
| 24 | 0.1397E+02 | 0.5880E+03 | 0.3192E+00 | 0.1499E+02 | 0.9998E+00 | 0.1882E-01 | 0.5750E+01 | 0.1937E+00 |
| 26 | 0.1405E+02 | 0.5890E+03 | 0.3060E+00 | 0.1499E+02 | 0.9999E+00 | -0.1296E-01 | 0.6250E+01 | 0.2000E+00 |
| 28 | 0.1409E+02 | 0.5895E+03 | 0.2986E+00 | 0.1499E+02 | 0.1000E+01 | 0.7636E-02 | 0.6750E+01 | 0.2000E+00 |
| 30 | 0.1411E+02 | 0.5897E+03 | 0.2947E+00 | 0.1499E+02 | 0.1000E+01 | 0.4018E-02 | 0.7250E+01 | 0.2000E+00 |
| 32 | 0.1412E+02 | 0.5897E+03 | 0.2926E+00 | 0.1498E+02 | 0.1000E+01 | 0.1948E-02 | 0.7750E+01 | 0.2000E+00 |

| BLOCK 1 VARIABLES AT K = 4 | | | | ITERATION NUMBER: 2500 | | | | |
|----------------------------|------------|-------------|-------------|------------------------|------------|-------------|------------|------------|
| J | PRESSURE | TEMPERATURE | MACH NUMBER | TOTAL PRESS | U-COSINE | V-COSINE | X | Y |
| 2 | 0.1016E+02 | 0.5369E+03 | 0.7672E+00 | 0.1500E+02 | 0.1000E+01 | -0.2308E-04 | 0.2500E+00 | 0.3000E+00 |
| 4 | 0.1017E+02 | 0.5369E+03 | 0.7670E+00 | 0.1501E+02 | 0.1000E+01 | 0.4941E-04 | 0.7500E+00 | 0.3000E+00 |
| 6 | 0.1019E+02 | 0.5372E+03 | 0.7651E+00 | 0.1501E+02 | 0.1000E+01 | 0.1205E-02 | 0.1250E+01 | 0.3000E+00 |
| 8 | 0.1032E+02 | 0.5392E+03 | 0.7513E+00 | 0.1500E+02 | 0.9999E+00 | 0.1051E-01 | 0.1750E+01 | 0.3000E+00 |
| 10 | 0.1090E+02 | 0.5478E+03 | 0.6874E+00 | 0.1496E+02 | 0.9989E+00 | 0.4461E-01 | 0.2250E+01 | 0.3187E+00 |
| 12 | 0.1199E+02 | 0.5630E+03 | 0.5736E+00 | 0.1499E+02 | 0.9978E+00 | 0.6683E-01 | 0.2750E+01 | 0.3562E+00 |
| 14 | 0.1266E+02 | 0.5717E+03 | 0.4973E+00 | 0.1499E+02 | 0.9973E+00 | 0.7311E-01 | 0.3250E+01 | 0.3937E+00 |
| 16 | 0.1312E+02 | 0.5776E+03 | 0.4408E+00 | 0.1499E+02 | 0.9972E+00 | 0.7453E-01 | 0.3750E+01 | 0.4312E+00 |
| 18 | 0.1344E+02 | 0.5816E+03 | 0.3975E+00 | 0.1499E+02 | 0.9973E+00 | 0.7383E-01 | 0.4250E+01 | 0.4687E+00 |
| 20 | 0.1368E+02 | 0.5846E+03 | 0.3635E+00 | 0.1499E+02 | 0.9975E+00 | 0.7117E-01 | 0.4750E+01 | 0.5062E+00 |
| 22 | 0.1386E+02 | 0.5867E+03 | 0.3366E+00 | 0.1499E+02 | 0.9979E+00 | 0.6521E-01 | 0.5250E+01 | 0.5437E+00 |
| 24 | 0.1399E+02 | 0.5883E+03 | 0.3164E+00 | 0.1499E+02 | 0.9985E+00 | 0.5396E-01 | 0.5750E+01 | 0.5812E+00 |
| 26 | 0.1407E+02 | 0.5892E+03 | 0.3034E+00 | 0.1500E+02 | 0.9994E+00 | 0.3489E-01 | 0.6250E+01 | 0.6000E+00 |
| 28 | 0.1410E+02 | 0.5896E+03 | 0.2972E+00 | 0.1500E+02 | 0.9998E+00 | 0.1937E-01 | 0.6750E+01 | 0.6000E+00 |
| 30 | 0.1412E+02 | 0.5898E+03 | 0.2944E+00 | 0.1499E+02 | 0.1000E+01 | 0.9811E-02 | 0.7250E+01 | 0.6000E+00 |
| 32 | 0.1412E+02 | 0.5898E+03 | 0.2930E+00 | 0.1499E+02 | 0.1000E+01 | 0.4713E-02 | 0.7750E+01 | 0.6000E+00 |

Listing E-3. Concluded

| BLOCK 1 VARIABLES AT K = 6 | | | | ITERATION NUMBER: | | 2500 | | | |
|----------------------------|------------|-------------|-------------|-------------------|------------|-------------|------------|------------|--|
| J | PRESSURE | TEMPERATURE | MACH NUMBER | TOTAL PRESS | U-COSINE | V-COSINE | X | Y | |
| 2 | 0.1016E+02 | 0.5369E+03 | 0.7672E+00 | 0.1501E+02 | 0.1000E+01 | -0.3146E-04 | 0.2500E+00 | 0.5000E+00 | |
| 4 | 0.1017E+02 | 0.5369E+03 | 0.7673E+00 | 0.1501E+02 | 0.1000E+01 | 0.3506E-04 | 0.7500E+00 | 0.5000E+00 | |
| 6 | 0.1017E+02 | 0.5370E+03 | 0.7671E+00 | 0.1501E+02 | 0.1000E+01 | 0.1398E-02 | 0.1250E+01 | 0.5000E+00 | |
| 8 | 0.1023E+02 | 0.5379E+03 | 0.7609E+00 | 0.1501E+02 | 0.9999E+00 | 0.1487E-01 | 0.1750E+01 | 0.5000E+00 | |
| 10 | 0.1076E+02 | 0.5457E+03 | 0.6996E+00 | 0.1491E+02 | 0.9966E+00 | 0.8295E-01 | 0.2250E+01 | 0.5312E+00 | |
| 12 | 0.1200E+02 | 0.5632E+03 | 0.5715E+00 | 0.1498E+02 | 0.9934E+00 | 0.1148E+00 | 0.2750E+01 | 0.5937E+00 | |
| 14 | 0.1268E+02 | 0.5721E+03 | 0.4941E+00 | 0.1499E+02 | 0.9924E+00 | 0.1227E+00 | 0.3250E+01 | 0.6562E+00 | |
| 16 | 0.1314E+02 | 0.5779E+03 | 0.4378E+00 | 0.1499E+02 | 0.9923E+00 | 0.1238E+00 | 0.3750E+01 | 0.7187E+00 | |
| 18 | 0.1347E+02 | 0.5819E+03 | 0.3946E+00 | 0.1499E+02 | 0.9925E+00 | 0.1224E+00 | 0.4250E+01 | 0.7812E+00 | |
| 20 | 0.1371E+02 | 0.5849E+03 | 0.3601E+00 | 0.1499E+02 | 0.9930E+00 | 0.1184E+00 | 0.4750E+01 | 0.8437E+00 | |
| 22 | 0.1389E+02 | 0.5871E+03 | 0.3321E+00 | 0.1499E+02 | 0.9940E+00 | 0.1095E+00 | 0.5250E+01 | 0.9062E+00 | |
| 24 | 0.1403E+02 | 0.5888E+03 | 0.3099E+00 | 0.1499E+02 | 0.9959E+00 | 0.9085E-01 | 0.5750E+01 | 0.9687E+00 | |
| 26 | 0.1411E+02 | 0.5898E+03 | 0.2967E+00 | 0.1500E+02 | 0.9985E+00 | 0.5403E-01 | 0.6250E+01 | 0.1000E+01 | |
| 28 | 0.1413E+02 | 0.5900E+03 | 0.2931E+00 | 0.1500E+02 | 0.9996E+00 | 0.2721E-01 | 0.6750E+01 | 0.1000E+01 | |
| 30 | 0.1413E+02 | 0.5900E+03 | 0.2921E+00 | 0.1499E+02 | 0.9999E+00 | 0.1276E-01 | 0.7250E+01 | 0.1000E+01 | |
| 32 | 0.1413E+02 | 0.5900E+03 | 0.2917E+00 | 0.1499E+02 | 0.1000E+01 | 0.5926E-02 | 0.7750E+01 | 0.1000E+01 | |

| BLOCK 1 VARIABLES AT K = 8 | | | | ITERATION NUMBER: | | 2500 | | | |
|----------------------------|------------|-------------|-------------|-------------------|------------|-------------|------------|------------|--|
| J | PRESSURE | TEMPERATURE | MACH NUMBER | TOTAL PRESS | U-COSINE | V-COSINE | X | Y | |
| 2 | 0.1016E+02 | 0.5369E+03 | 0.7673E+00 | 0.1501E+02 | 0.1000E+01 | -0.2826E-04 | 0.2500E+00 | 0.7000E+00 | |
| 4 | 0.1016E+02 | 0.5368E+03 | 0.7676E+00 | 0.1501E+02 | 0.1000E+01 | -0.9063E-05 | 0.7500E+00 | 0.7000E+00 | |
| 6 | 0.1015E+02 | 0.5367E+03 | 0.7696E+00 | 0.1502E+02 | 0.1000E+01 | 0.8392E-03 | 0.1250E+01 | 0.7000E+00 | |
| 8 | 0.1009E+02 | 0.5357E+03 | 0.7771E+00 | 0.1504E+02 | 0.9999E+00 | 0.1374E-01 | 0.1750E+01 | 0.7000E+00 | |
| 10 | 0.1052E+02 | 0.5424E+03 | 0.7178E+00 | 0.1483E+02 | 0.9922E+00 | 0.1248E+00 | 0.2250E+01 | 0.7437E+00 | |
| 12 | 0.1204E+02 | 0.5638E+03 | 0.5678E+00 | 0.1499E+02 | 0.9863E+00 | 0.1652E+00 | 0.2750E+01 | 0.8312E+00 | |
| 14 | 0.1272E+02 | 0.5728E+03 | 0.4895E+00 | 0.1499E+02 | 0.9850E+00 | 0.1725E+00 | 0.3250E+01 | 0.9187E+00 | |
| 16 | 0.1318E+02 | 0.5785E+03 | 0.4323E+00 | 0.1498E+02 | 0.9849E+00 | 0.1729E+00 | 0.3750E+01 | 0.1006E+01 | |
| 18 | 0.1350E+02 | 0.5825E+03 | 0.3882E+00 | 0.1498E+02 | 0.9852E+00 | 0.1714E+00 | 0.4250E+01 | 0.1094E+01 | |
| 20 | 0.1374E+02 | 0.5855E+03 | 0.3522E+00 | 0.1497E+02 | 0.9858E+00 | 0.1676E+00 | 0.4750E+01 | 0.1181E+01 | |
| 22 | 0.1393E+02 | 0.5878E+03 | 0.3214E+00 | 0.1497E+02 | 0.9874E+00 | 0.1585E+00 | 0.5250E+01 | 0.1269E+01 | |
| 24 | 0.1409E+02 | 0.5898E+03 | 0.2948E+00 | 0.1497E+02 | 0.9908E+00 | 0.1350E+00 | 0.5750E+01 | 0.1356E+01 | |
| 26 | 0.1419E+02 | 0.5909E+03 | 0.2808E+00 | 0.1498E+02 | 0.9977E+00 | 0.6798E-01 | 0.6250E+01 | 0.1400E+01 | |
| 28 | 0.1416E+02 | 0.5906E+03 | 0.2822E+00 | 0.1497E+02 | 0.9996E+00 | 0.2931E-01 | 0.6750E+01 | 0.1400E+01 | |
| 30 | 0.1415E+02 | 0.5904E+03 | 0.2844E+00 | 0.1496E+02 | 0.9999E+00 | 0.1225E-01 | 0.7250E+01 | 0.1400E+01 | |
| 32 | 0.1414E+02 | 0.5904E+03 | 0.2861E+00 | 0.1497E+02 | 0.1000E+01 | 0.5173E-02 | 0.7750E+01 | 0.1400E+01 | |

| BLOCK 1 VARIABLES AT K = 10 | | | | ITERATION NUMBER: | | 2500 | | | |
|-----------------------------|------------|-------------|-------------|-------------------|------------|-------------|------------|------------|--|
| J | PRESSURE | TEMPERATURE | MACH NUMBER | TOTAL PRESS | U-COSINE | V-COSINE | X | Y | |
| 2 | 0.1016E+02 | 0.5368E+03 | 0.7674E+00 | 0.1501E+02 | 0.1000E+01 | -0.1145E-04 | 0.2500E+00 | 0.9000E+00 | |
| 4 | 0.1016E+02 | 0.5368E+03 | 0.7678E+00 | 0.1501E+02 | 0.1000E+01 | -0.3947E-05 | 0.7500E+00 | 0.9000E+00 | |
| 6 | 0.1014E+02 | 0.5364E+03 | 0.7717E+00 | 0.1503E+02 | 0.1000E+01 | -0.9950E-04 | 0.1250E+01 | 0.9000E+00 | |
| 8 | 0.9853E+01 | 0.5322E+03 | 0.8056E+00 | 0.1510E+02 | 0.1000E+01 | 0.2055E-02 | 0.1750E+01 | 0.9000E+00 | |
| 10 | 0.1019E+02 | 0.5383E+03 | 0.7348E+00 | 0.1459E+02 | 0.9844E+00 | 0.1761E+00 | 0.2250E+01 | 0.9562E+00 | |
| 12 | 0.1211E+02 | 0.5654E+03 | 0.5489E+00 | 0.1487E+02 | 0.9752E+00 | 0.2213E+00 | 0.2750E+01 | 0.1069E+01 | |
| 14 | 0.1278E+02 | 0.5740E+03 | 0.4725E+00 | 0.1489E+02 | 0.9743E+00 | 0.2254E+00 | 0.3250E+01 | 0.1181E+01 | |
| 16 | 0.1323E+02 | 0.5796E+03 | 0.4180E+00 | 0.1491E+02 | 0.9746E+00 | 0.2237E+00 | 0.3750E+01 | 0.1294E+01 | |
| 18 | 0.1354E+02 | 0.5834E+03 | 0.3758E+00 | 0.1493E+02 | 0.9751E+00 | 0.2218E+00 | 0.4250E+01 | 0.1406E+01 | |
| 20 | 0.1378E+02 | 0.5863E+03 | 0.3407E+00 | 0.1493E+02 | 0.9756E+00 | 0.2195E+00 | 0.4750E+01 | 0.1519E+01 | |
| 22 | 0.1398E+02 | 0.5887E+03 | 0.3085E+00 | 0.1493E+02 | 0.9768E+00 | 0.2141E+00 | 0.5250E+01 | 0.1631E+01 | |
| 24 | 0.1418E+02 | 0.5911E+03 | 0.2733E+00 | 0.1493E+02 | 0.9796E+00 | 0.2009E+00 | 0.5750E+01 | 0.1744E+01 | |
| 26 | 0.1431E+02 | 0.5927E+03 | 0.2609E+00 | 0.1500E+02 | 0.9981E+00 | 0.6208E-01 | 0.6250E+01 | 0.1800E+01 | |
| 28 | 0.1420E+02 | 0.5913E+03 | 0.2760E+00 | 0.1497E+02 | 0.9999E+00 | 0.1251E-01 | 0.6750E+01 | 0.1800E+01 | |
| 30 | 0.1416E+02 | 0.5908E+03 | 0.2818E+00 | 0.1496E+02 | 0.1000E+01 | 0.2368E-02 | 0.7250E+01 | 0.1800E+01 | |
| 32 | 0.1414E+02 | 0.5907E+03 | 0.2842E+00 | 0.1496E+02 | 0.1000E+01 | 0.8518E-03 | 0.7750E+01 | 0.1800E+01 | |

Listing E-4. Grid and Initial Condition Generator (3-D)

```

1  1.  PROGRAM ICFILE
2  2.  PARAMETER(JD=33,KD=11,LD=21)
3  3.  DIMENSION R(JD,KD,LD),RU(JD,KD,LD),RV(JD,KD,LD)
4  4.  DIMENSION RW(JD,KD,LD),E(JD,KD,LD)
5  5.  DIMENSION X(JD,KD,LD),Y(JD,KD,LD),Z(JD,KD,LD)
6  6.  DATA G/1.4/
7  7.  GM1=G-1.
8  8.  DELX=8./32
9  9.  C FORM THE 'X' GRID ARRAY
10 10. DO 1 J=1,JD
11 11. DO 1 K=1,KD
12 12. IF(J.EQ.1) THEN
13 13. X(J,K,11)=0.
14 14. ELSE
15 15. X(J,K,11)=X(J-1,K,11)+DELX
16 16. ENDDIF
17 17. CONTINUE
18 18. C FORM THE 'Y' AND 'Z' GRID ARRAYS
19 19. DO 2 J=1,JD
20 20. IF(X(J,KD,11).LE.2.) YO=1.
21 21. IF(X(J,KD,11).GT.6.) YO=2.
22 22. IF((X(J,KD,11).GT.2.) .AND. (X(J,KD,11).LE.6.)) THEN
23 23. YO=1.+(X(J,KD,11)-2.)*0.25
24 24. ENDDIF
25 25. DELY=YO/(KD-1)
26 26. Y(J,1,11)=0.0
27 27. Z(J,1,11)=0.0
28 28. DO 2 K=2,KD
29 29. Y(J,K,11)=Y(J,K-1,11)+DELY
30 30. Z(J,K,11)=0.0
31 31. CONTINUE
32 32. C FORM THE ARRAYS OF NON-DIMENSIONAL CONSERVATION VARIABLES
33 33. C CONSISTENT WITH A FREE-STREAM MACH NUMBER OF 0.29
34 34. FMACH=0.29
35 35. FACT=(1.+2.*FMACH**2)
36 36. PBAR=FACT**(-3.5)/G
37 37. DO 1000 J=1,JD
38 38. DO 2000 K=1,KD
39 39. R(J,K,11)=FACT**(-2.5)
40 40. RU(J,K,11)=R(J,K,11)*FMACH*SQRT(1./FACT)
41 41. RV(J,K,11)=0.
42 42. RW(J,K,11)=0.
43 43. E(J,K,11)=PBAR/GM1+.5*(RU(J,K,11)**2)/R(J,K,11)
44 44. CONTINUE
45 45. CONTINUE

```

Listing E-4. Concluded

```

46      C EXTRAPOLATE THE GRID & CONSERVATION VARIABLES INTO THE 'Z' PLANE
47      42.  DELZ = 0.25
48      43.  DO 100 L=12,21
49      44.  DO 100 J=1,JD
50      45.  DO 100 K=1,KD
51      46.  M=22-L
52      47.  X(J,K,L)=X(J,K,11)
53      48.  X(J,K,M)=X(J,K,11)
54      49.  Y(J,K,L)=Y(J,K,11)
55      50.  Y(J,K,M)=Y(J,K,11)
56      51.  Z(J,K,L)=Z(J,K,11)+DELZ*(L-11)
57      52.  Z(J,K,M)=Z(J,K,L)
58      53.  R(J,K,L)=R(J,K,11)
59      54.  R(J,K,M)=R(J,K,11)
60      55.  RU(J,K,L)=RU(J,K,11)
61      56.  RU(J,K,M)=RU(J,K,11)
62      57.  RV(J,K,L)=RV(J,K,11)
63      58.  RV(J,K,M)=RV(J,K,11)
64      59.  RW(J,K,L)=RW(J,K,11)
65      60.  RW(J,K,M)=RW(J,K,11)
66      61.  E(J,K,L)=E(J,K,11)
67      62.  E(J,K,M)=E(J,K,11)
68      63. 100 CONTINUE
69      64.  NC1=0
70      65.  WRITE(20)NC1,G
71      66.  WRITE(20)JD,KD,LD
72      67.  WRITE(20)X,Y,Z
73      68.  WRITE(20)R,RU,RV,RW,E
74      69.  STOP
75      70.  END

```

Listing E-5. Execution and Input File (3-D)

```

//A05569X JOB (SVT,ATT00000,00,78904912),'DON TODD EL2 CFD',
// CLASS=X,TIME=(,5),USER=A05569,PASSWORD=XXXXXXXX,MSGCLASS=Z,
// MSGLEVEL=1,PRTY=8,NOTIFY=A05569
/**
/*ROUTE PRINT RMTD
/*JOBPARM ROOM=5 2ND FLOOR DO BLDG 1099
/**
// EXEC CRAY
CRSUBMIT F(OSJOB) NOTIFY(A05569) DEST(RMTD) PRINT(A) HOLD
//OSJOB DD *
JOB,JN=A05569Y,T=900,MFL.
ACCOUNT,AC=78904910,US=A05569.
FETCH,DN=CODE,TEXT='DSN=A05569.BARC(BARC3D),DISP=SHR'.
CFT,I=CODE,L=0.
ACCESS,DN=BNCHLIB,PDM=BNCHLIB,ID=BNCHMRK,OWN=SYSTEM.
ACCESS,DN=FT02,PDM=ICCASE2.
LDR,LIB=BNCHLIB.
*SAVE,DN=FT04,PDM=RSCASE2.
DISPOSE,DN=FT04,DC=ST,DF=TR,TEXT='
'DSN=A05569.TRCASE2.REST,DISP=(,CATLG),
'UNIT=DISK,SPACE=(CYL,(38),RLSE),
'DCB=(RECFM=F,LRECL=4096,BLKSIZE=4096)'.
/EOF
$INPUTS
MMAX=2500, NP=2500, NBLOCK=1,
:JMAX=33, KMAX=11, LMAX=21,
PREF=15.0, TREFR=600.,
IFXPRT=1,
DIS2=0.0, DIS4=0.30,
DTCAP=4.0, PCOMAX=10.0,
NSPRT=50, STOPL2=1.E-20,
$SEND
$BLOCK
MPSEG=3,
INVISC(1)=0, INVISC(2)=0, INVISC(3)=0,
$SEND
$SPRTSEG
JKLPI(1,1,1)=1,33,4, JKLPI(1,2,1)=1,11,1,
JKLPI(1,3,1)=11,11,1, IPORD(1,1)=2,1,
JKLPI(1,1,2)=2,23,2, JKLPI(1,2,2)=2,10,2,
JKLPI(1,3,2)=11,11,1, IPORD(1,2)=1,2,
JKLPI(1,1,3)=10,30,10, JKLPI(1,2,3)=4,8,4,
JKLPI(1,3,3)=1,21,1, IPORD(1,3)=3,1,
$SEND
$BOUNDS
NJSEG=2,
JLINE(1)=1, JTYPE(1)=0, JSIGN(1)=1,
JKLOW(1)=2, JKHIGH(1)=10,
JLLOW(1)=2, JLHIGH(1)=20,
PRESSJ(1)=0.7142857, TEMPJ(1)=1.0,
JLINE(2)=33, JTYPE(2)=0, JSIGN(2)=-1,
JKLOW(2)=2, JKHIGH(2)=10,
JLLOW(2)=2, JLHIGH(2)=20,
PRESSJ(2)=0.67285, TEMPJ(2)=1.0,
NKSEG=2,
KLINE(1)=1, KTYPE(1)=50, KSIGN(1)=1,
KJLOW(1)=1, KJHIGH(1)=33,
KLLow(1)=1, KLHIGH(1)=21,
KLINE(2)=11, KTYPE(2)=50, KSIGN(2)=-1,
KJLOW(2)=1, KJHIGH(2)=33,
KLLow(2)=1, KLHIGH(2)=21,
NLSEG=2,
LLINE(1)=1, LTYPE(1)=50, LSIGN(1)=1,
LJLOW(1)=1, LJHIGH(1)=33,
LKLOW(1)=2, LKHIGH(1)=10,
LLINE(2)=21, LTYPE(2)=50, LSIGN(2)=-1,
LJLOW(2)=1, LJHIGH(2)=33,
LKLOW(2)=2, LKHIGH(2)=10,
$SEND
/EOJ

```

Listing E-6. Diverging Nozzle Output (3-D)

NAMELIST INPUTS:

```

PREF = 0.150000E+02      NBLOCK = 1
TREFR = 0.600000E+03     NMAX = 2500
VRAT = -0.666667E+00     NC = 0
TSUTH = 0.198600E+03     NSPRT = 50
RE = 0.000000E+00       NP = 2500
PR = 0.720000E+00       IFXPRT = 1
PRT = 0.900000E+00      IFXPRT = 0
DIS2 = 0.000000E+00     LZPLOT = 0
DIS4 = 0.300000E+00     IPLOT = 0
DTCAP = 0.400000E+01    LMODE = 1
PCOMAX = 0.100000E+02   MRCRD = 1
SPLEND = 0.100000E+01   NUMDT = 0
SMOO = 0.000000E+00     IVARDT = 2
STOPL2 = 0.100000E-19   ISOLVE = 1
STOPTR = 0.500000E+01   IRHS = 1
ALPHA = 0.000000E+00    IFILTR = 1
BETA = 0.000000E+00     INUTUR = 1
XMACH = 0.000000E+00

```

THE ORDER OF BLOCK PROCESSING FOLLOWS
1

FOR BLOCK 1
JMAX = 33 KMAX = 11 LMAX = 21
NM = 33 NIP = 693 IJKL = 7623

```

NAMELIST BLOCK FOR BLOCK 1
GAMMA = 0.140000E+01     INVISC = 0 0 0
COFMIX = 0.900000E-01    LAMIN = 0 0 0
DTBLK = 0.000000E+00     NPSEG = 3
                               NBCSEG = 0

```

NAMELIST PRTSEG FOR BLOCK 1

| | JKLPI | | | IPORD | | | | | | | |
|---|-------|----|----|-------|----|----|----|----|----|---|---|
| | JA | JB | JS | KA | KB | KS | LA | LB | LS | J | K |
| 1 | .1 | 33 | 4 | 1 | 11 | 1 | 11 | 11 | 1 | 2 | 1 |
| 2 | 2 | 23 | 2 | 2 | 10 | 2 | 11 | 11 | 1 | 1 | 2 |
| 3 | 10 | 30 | 10 | 4 | 8 | 4 | 1 | 21 | 1 | 3 | 1 |

NAMELIST BOUNDS FOR BLOCK 1

| JSEG | JLINE | JKLOW | JKHIGH | JLLOW | JLHIGH | JTYPE | INTERJ | JSIGN | PRESSJ | TEMPJ | JTYPE |
|------|-------|-------|--------|-------|--------|-------|--------|-------|--------------|--------------|-------|
| 1 | 1 | 2 | 10 | 2 | 20 | 0 | | 1 | 0.714286E+00 | 0.100000E+01 | FREE |
| 2 | 33 | 2 | 10 | 2 | 20 | 0 | | -1 | 0.672850E+00 | 0.100000E+01 | FREE |
| KSEG | KLINE | KJLOW | KJHIGH | KLLOW | KLHIGH | KTYPE | INTERK | KSIGN | PRESSK | TEMPK | KTYPE |
| 1 | 1 | 1 | 33 | 1 | 21 | 50 | | 1 | | | SLIP |
| 2 | 11 | 1 | 33 | 1 | 21 | 50 | | -1 | | | SLIP |
| LSEG | LLINE | LJLOW | LJHIGH | LKLOW | LKHIGH | LTYPE | INTERL | LSIGN | PRESSL | TEMPL | LTYPE |
| 1 | 1 | 1 | 33 | 2 | 10 | 50 | | 1 | | | SLIP |
| 2 | 21 | 1 | 33 | 2 | 10 | 50 | | -1 | | | SLIP |

GRID PATCHES FOR BLOCK 1

| J-PATCHES | MINIMUM | | | MAXIMUM | | |
|-----------|---------|---|---|---------|----|----|
| | J | K | L | J | K | L |
| 1 | 2 | 2 | 2 | 32 | 10 | 20 |

| K-PATCHES | MINIMUM | | | MAXIMUM | | |
|-----------|---------|---|---|---------|----|----|
| | J | K | L | J | K | L |
| 1 | 2 | 2 | 2 | 32 | 10 | 20 |

| L-PATCHES | MINIMUM | | | MAXIMUM | | |
|-----------|---------|---|---|---------|----|----|
| | J | K | L | J | K | L |
| 1 | 2 | 2 | 2 | 32 | 10 | 20 |

Listing E-6. Continued

| COUNT | BLOCK | DT | L2 RESIDUAL | MASS FLUX | MOMENTUM FLUXES | | | ENERGY FLUX | MAX PERCENT VARIATION | MAX LOCATION | | |
|-------|-------|------------|-------------|-------------|-----------------|------------|-------------|-------------|-----------------------|--------------|----|----|
| | | | | | X | Y | Z | | | J | K | L |
| 50 | 1 | 0.4000E+01 | 0.8454E-04 | -0.2655E-02 | 0.1904E-02 | 0.4166E-02 | -0.4503E+01 | -0.3451E-02 | 0.1228E+01 | 32 | 10 | 2 |
| 100 | 1 | 0.4000E+01 | 0.1924E-04 | 0.3311E-03 | 0.3661E-02 | 0.4076E-02 | -0.7677E-01 | 0.6769E-03 | 0.1808E+00 | 32 | 10 | 2 |
| 150 | 1 | 0.4000E+01 | 0.9179E-05 | -0.7729E-04 | 0.1970E-02 | 0.1685E-02 | 0.3355E-01 | 0.8445E-04 | 0.8304E-01 | 4 | 10 | 2 |
| 200 | 1 | 0.4000E+01 | 0.7648E-05 | -0.2531E-03 | 0.1111E-02 | 0.9213E-03 | -0.9054E-02 | -0.2033E-03 | 0.1044E+00 | 9 | 10 | 2 |
| 250 | 1 | 0.4000E+01 | 0.5695E-05 | -0.1990E-03 | 0.7879E-03 | 0.6606E-03 | -0.2814E-01 | -0.1621E-03 | 0.8569E-01 | 9 | 10 | 20 |
| 300 | 1 | 0.4000E+01 | 0.4205E-05 | -0.1436E-03 | 0.5746E-03 | 0.4711E-03 | -0.2434E-01 | -0.1108E-03 | 0.6530E-01 | 9 | 10 | 2 |
| 350 | 1 | 0.4000E+01 | 0.3255E-05 | -0.1120E-03 | 0.4119E-03 | 0.3305E-03 | -0.2747E-01 | -0.8689E-04 | 0.5203E-01 | 9 | 10 | 20 |
| 400 | 1 | 0.4000E+01 | 0.2519E-05 | -0.8790E-04 | 0.2985E-03 | 0.2367E-03 | -0.2418E-01 | -0.6917E-04 | 0.4144E-01 | 9 | 10 | 20 |
| 450 | 1 | 0.4000E+01 | 0.1934E-05 | -0.6783E-04 | 0.2197E-03 | 0.1695E-03 | -0.2764E-01 | -0.5355E-04 | 0.3243E-01 | 9 | 10 | 20 |
| 500 | 1 | 0.4000E+01 | 0.1485E-05 | -0.5221E-04 | 0.1629E-03 | 0.1252E-03 | -0.2565E-01 | -0.4130E-04 | 0.2522E-01 | 9 | 10 | 20 |
| 550 | 1 | 0.4000E+01 | 0.1147E-05 | -0.4020E-04 | 0.1216E-03 | 0.9262E-04 | -0.2766E-01 | -0.3189E-04 | 0.1955E-01 | 9 | 10 | 20 |
| 600 | 1 | 0.4000E+01 | 0.8755E-06 | -0.3090E-04 | 0.9121E-04 | 0.6816E-04 | -0.2625E-01 | -0.2456E-04 | 0.1511E-01 | 9 | 10 | 20 |
| 650 | 1 | 0.4000E+01 | 0.6714E-06 | -0.2372E-04 | 0.6875E-04 | 0.5168E-04 | -0.2778E-01 | -0.1888E-04 | 0.1165E-01 | 9 | 10 | 20 |
| 700 | 1 | 0.4000E+01 | 0.5147E-06 | -0.1820E-04 | 0.5199E-04 | 0.3861E-04 | -0.2673E-01 | -0.1450E-04 | 0.8963E-02 | 9 | 10 | 20 |
| 750 | 1 | 0.4000E+01 | 0.3944E-06 | -0.1395E-04 | 0.3942E-04 | 0.2908E-04 | -0.2766E-01 | -0.1113E-04 | 0.6889E-02 | 9 | 10 | 20 |
| 800 | 1 | 0.4000E+01 | 0.3021E-06 | -0.1069E-04 | 0.2996E-04 | 0.2224E-04 | -0.2716E-01 | -0.8532E-05 | 0.5288E-02 | 9 | 10 | 20 |
| 850 | 1 | 0.4000E+01 | 0.2314E-06 | -0.8193E-05 | 0.2280E-04 | 0.1670E-04 | -0.2750E-01 | -0.6541E-05 | 0.4057E-02 | 9 | 10 | 20 |
| 900 | 1 | 0.4000E+01 | 0.1772E-06 | -0.6275E-05 | 0.1737E-04 | 0.1279E-04 | -0.2746E-01 | -0.5011E-05 | 0.3110E-02 | 9 | 10 | 20 |
| 950 | 1 | 0.4000E+01 | 0.1356E-06 | -0.4806E-05 | 0.1326E-04 | 0.9744E-05 | -0.2741E-01 | -0.3839E-05 | 0.2384E-02 | 9 | 10 | 20 |
| 1000 | 1 | 0.4000E+01 | 0.1038E-06 | -0.3680E-05 | 0.1012E-04 | 0.7381E-05 | -0.2758E-01 | -0.2940E-05 | 0.1826E-02 | 9 | 10 | 20 |
| 1050 | 1 | 0.4000E+01 | 0.7948E-07 | -0.2817E-05 | 0.7729E-05 | 0.5682E-05 | -0.2743E-01 | -0.2251E-05 | 0.1399E-02 | 9 | 10 | 20 |
| 1100 | 1 | 0.4000E+01 | 0.6084E-07 | -0.2156E-05 | 0.5907E-05 | 0.4312E-05 | -0.2759E-01 | -0.1723E-05 | 0.1071E-02 | 9 | 10 | 20 |
| 1150 | 1 | 0.4000E+01 | 0.4656E-07 | -0.1651E-05 | 0.4515E-05 | 0.3298E-05 | -0.2746E-01 | -0.1319E-05 | 0.8201E-03 | 9 | 10 | 20 |
| 1200 | 1 | 0.4000E+01 | 0.3564E-07 | -0.1263E-05 | 0.3453E-05 | 0.2531E-05 | -0.2762E-01 | -0.1010E-05 | 0.6278E-03 | 9 | 10 | 20 |
| 1250 | 1 | 0.4000E+01 | 0.2727E-07 | -0.9671E-06 | 0.2640E-05 | 0.1922E-05 | -0.2745E-01 | -0.7731E-06 | 0.4806E-03 | 9 | 10 | 20 |
| 1300 | 1 | 0.4000E+01 | 0.2087E-07 | -0.7402E-06 | 0.2020E-05 | 0.1479E-05 | -0.2765E-01 | -0.5917E-06 | 0.3679E-03 | 9 | 10 | 20 |
| 1350 | 1 | 0.4000E+01 | 0.1597E-07 | -0.5665E-06 | 0.1545E-05 | 0.1128E-05 | -0.2746E-01 | -0.4529E-06 | 0.2816E-03 | 9 | 10 | 20 |
| 1400 | 1 | 0.4000E+01 | 0.1222E-07 | -0.4336E-06 | 0.1182E-05 | 0.8615E-06 | -0.2763E-01 | -0.3466E-06 | 0.2155E-03 | 9 | 10 | 20 |
| 1450 | 1 | 0.4000E+01 | 0.9355E-08 | -0.3318E-06 | 0.9045E-06 | 0.6622E-06 | -0.2751E-01 | -0.2653E-06 | 0.1650E-03 | 9 | 10 | 20 |
| 1500 | 1 | 0.4000E+01 | 0.7159E-08 | -0.2540E-06 | 0.6921E-06 | 0.5042E-06 | -0.2758E-01 | -0.2030E-06 | 0.1263E-03 | 9 | 10 | 20 |
| 1550 | 1 | 0.4000E+01 | 0.5479E-08 | -0.1944E-06 | 0.5296E-06 | 0.3868E-06 | -0.2756E-01 | -0.1554E-06 | 0.9663E-04 | 9 | 10 | 20 |
| 1600 | 1 | 0.4000E+01 | 0.4193E-08 | -0.1487E-06 | 0.4053E-06 | 0.2961E-06 | -0.2756E-01 | -0.1189E-06 | 0.7395E-04 | 9 | 10 | 20 |
| 1650 | 1 | 0.4000E+01 | 0.3209E-08 | -0.1138E-06 | 0.3101E-06 | 0.2259E-06 | -0.2756E-01 | -0.9102E-07 | 0.5660E-04 | 9 | 10 | 20 |
| 1700 | 1 | 0.4000E+01 | 0.2456E-08 | -0.8712E-07 | 0.2373E-06 | 0.1736E-06 | -0.2757E-01 | -0.6966E-07 | 0.4332E-04 | 9 | 10 | 20 |
| 1750 | 1 | 0.4000E+01 | 0.1879E-08 | -0.6668E-07 | 0.1816E-06 | 0.1324E-06 | -0.2754E-01 | -0.5331E-07 | 0.3315E-04 | 9 | 10 | 20 |
| 1800 | 1 | 0.4000E+01 | 0.1438E-08 | -0.5103E-07 | 0.1390E-06 | 0.1014E-06 | -0.2756E-01 | -0.4080E-07 | 0.2537E-04 | 9 | 10 | 20 |
| 1850 | 1 | 0.4000E+01 | 0.1101E-08 | -0.3905E-07 | 0.1064E-06 | 0.7774E-07 | -0.2756E-01 | -0.3122E-07 | 0.1942E-04 | 9 | 10 | 20 |
| 1900 | 1 | 0.4000E+01 | 0.8423E-09 | -0.2989E-07 | 0.8140E-07 | 0.5932E-07 | -0.2750E-01 | -0.2390E-07 | 0.1486E-04 | 9 | 10 | 20 |
| 1950 | 1 | 0.4000E+01 | 0.6447E-09 | -0.2287E-07 | 0.6229E-07 | 0.4551E-07 | -0.2760E-01 | -0.1829E-07 | 0.1137E-04 | 9 | 10 | 20 |
| 2000 | 1 | 0.4000E+01 | 0.4933E-09 | -0.1750E-07 | 0.4767E-07 | 0.3479E-07 | -0.2754E-01 | -0.1400E-07 | 0.8703E-05 | 9 | 10 | 20 |
| 2050 | 1 | 0.4000E+01 | 0.3776E-09 | -0.1340E-07 | 0.3648E-07 | 0.2661E-07 | -0.2752E-01 | -0.1071E-07 | 0.6661E-05 | 9 | 10 | 20 |
| 2100 | 1 | 0.4000E+01 | 0.2889E-09 | -0.1025E-07 | 0.2792E-07 | 0.2040E-07 | -0.2749E-01 | -0.8197E-08 | 0.5097E-05 | 9 | 10 | 20 |
| 2150 | 1 | 0.4000E+01 | 0.2211E-09 | -0.7846E-08 | 0.2137E-07 | 0.1558E-07 | -0.2738E-01 | -0.6273E-08 | 0.3901E-05 | 9 | 10 | 20 |
| 2200 | 1 | 0.4000E+01 | 0.1692E-09 | -0.6005E-08 | 0.1635E-07 | 0.1194E-07 | -0.2756E-01 | -0.4801E-08 | 0.2985E-05 | 9 | 10 | 20 |
| 2250 | 1 | 0.4000E+01 | 0.1295E-09 | -0.4595E-08 | 0.1251E-07 | 0.9138E-08 | -0.2758E-01 | -0.3674E-08 | 0.2285E-05 | 9 | 10 | 20 |
| 2300 | 1 | 0.4000E+01 | 0.9911E-10 | -0.3517E-08 | 0.9577E-08 | 0.6984E-08 | -0.2773E-01 | -0.2812E-08 | 0.1749E-05 | 9 | 10 | 20 |
| 2350 | 1 | 0.4000E+01 | 0.7585E-10 | -0.2691E-08 | 0.7330E-08 | 0.5354E-08 | -0.2750E-01 | -0.2152E-08 | 0.1338E-05 | 9 | 10 | 20 |
| 2400 | 1 | 0.4000E+01 | 0.5805E-10 | -0.2060E-08 | 0.5609E-08 | 0.4092E-08 | -0.2677E-01 | -0.1647E-08 | 0.1024E-05 | 9 | 10 | 20 |
| 2450 | 1 | 0.4000E+01 | 0.4443E-10 | -0.1576E-08 | 0.4293E-08 | 0.3133E-08 | -0.2777E-01 | -0.1260E-08 | 0.7838E-06 | 9 | 10 | 20 |
| 2500 | 1 | 0.4000E+01 | 0.3400E-10 | -0.1206E-08 | 0.3285E-08 | 0.2399E-08 | -0.2781E-01 | -0.9646E-09 | 0.5998E-06 | 9 | 10 | 20 |

Listing E-6. Continued

| BLOCK 1 VARIABLES AT L, J = 11, 1 | | | | ITERATION NUMBER: 2500 | | | | | | |
|-----------------------------------|------------|-------------|-------------|------------------------|------------|------------|------------|------------|------------|------------|
| K | PRESSURE | TEMPERATURE | MACH NUMBER | TOTAL PRESS | U-COSINE | V-COSINE | W-COSINE | X | Y | Z |
| 1 | 0.1018E+02 | 0.5370E+03 | 0.7656E+00 | 0.1500E+02 | 0.1000E+01 | 0.0000E+00 | 0.0000E+00 | 0.0000E+00 | 0.0000E+00 | 0.0000E+00 |
| 2 | 0.1018E+02 | 0.5370E+03 | 0.7656E+00 | 0.1500E+02 | 0.1000E+01 | 0.0000E+00 | 0.0000E+00 | 0.0000E+00 | 0.1000E+00 | 0.0000E+00 |
| 3 | 0.1018E+02 | 0.5370E+03 | 0.7656E+00 | 0.1500E+02 | 0.1000E+01 | 0.0000E+00 | 0.0000E+00 | 0.0000E+00 | 0.2000E+00 | 0.0000E+00 |
| 4 | 0.1018E+02 | 0.5370E+03 | 0.7656E+00 | 0.1500E+02 | 0.1000E+01 | 0.0000E+00 | 0.0000E+00 | 0.0000E+00 | 0.3000E+00 | 0.0000E+00 |
| 5 | 0.1018E+02 | 0.5370E+03 | 0.7657E+00 | 0.1500E+02 | 0.1000E+01 | 0.0000E+00 | 0.0000E+00 | 0.0000E+00 | 0.4000E+00 | 0.0000E+00 |
| 6 | 0.1018E+02 | 0.5370E+03 | 0.7657E+00 | 0.1500E+02 | 0.1000E+01 | 0.0000E+00 | 0.0000E+00 | 0.0000E+00 | 0.5000E+00 | 0.0000E+00 |
| 7 | 0.1018E+02 | 0.5370E+03 | 0.7657E+00 | 0.1500E+02 | 0.1000E+01 | 0.0000E+00 | 0.0000E+00 | 0.0000E+00 | 0.6000E+00 | 0.0000E+00 |
| 8 | 0.1018E+02 | 0.5370E+03 | 0.7657E+00 | 0.1500E+02 | 0.1000E+01 | 0.0000E+00 | 0.0000E+00 | 0.0000E+00 | 0.7000E+00 | 0.0000E+00 |
| 9 | 0.1017E+02 | 0.5370E+03 | 0.7658E+00 | 0.1500E+02 | 0.1000E+01 | 0.0000E+00 | 0.0000E+00 | 0.0000E+00 | 0.8000E+00 | 0.0000E+00 |
| 10 | 0.1017E+02 | 0.5370E+03 | 0.7658E+00 | 0.1500E+02 | 0.1000E+01 | 0.0000E+00 | 0.0000E+00 | 0.0000E+00 | 0.9000E+00 | 0.0000E+00 |
| 11 | 0.1017E+02 | 0.5370E+03 | 0.7658E+00 | 0.1500E+02 | 0.1000E+01 | 0.0000E+00 | 0.0000E+00 | 0.0000E+00 | 0.1000E+01 | 0.0000E+00 |

| BLOCK 1 VARIABLES AT L, J = 11, 5 | | | | ITERATION NUMBER: 2500 | | | | | | |
|-----------------------------------|------------|-------------|-------------|------------------------|------------|------------|-------------|------------|------------|------------|
| K | PRESSURE | TEMPERATURE | MACH NUMBER | TOTAL PRESS | U-COSINE | V-COSINE | W-COSINE | X | Y | Z |
| 1 | 0.1018E+02 | 0.5372E+03 | 0.7647E+00 | 0.1500E+02 | 0.1000E+01 | 0.0000E+00 | -0.1067E-12 | 0.1000E+01 | 0.0000E+00 | 0.0000E+00 |
| 2 | 0.1018E+02 | 0.5372E+03 | 0.7647E+00 | 0.1500E+02 | 0.1000E+01 | 0.2647E-03 | -0.1066E-12 | 0.1000E+01 | 0.1000E+00 | 0.0000E+00 |
| 3 | 0.1018E+02 | 0.5371E+03 | 0.7648E+00 | 0.1500E+02 | 0.1000E+01 | 0.5328E-03 | -0.1077E-12 | 0.1000E+01 | 0.2000E+00 | 0.0000E+00 |
| 4 | 0.1018E+02 | 0.5371E+03 | 0.7650E+00 | 0.1500E+02 | 0.1000E+01 | 0.7447E-03 | -0.1070E-12 | 0.1000E+01 | 0.3000E+00 | 0.0000E+00 |
| 5 | 0.1018E+02 | 0.5371E+03 | 0.7653E+00 | 0.1500E+02 | 0.1000E+01 | 0.9193E-03 | -0.1069E-12 | 0.1000E+01 | 0.4000E+00 | 0.0000E+00 |
| 6 | 0.1017E+02 | 0.5370E+03 | 0.7655E+00 | 0.1499E+02 | 0.1000E+01 | 0.1000E-02 | -0.1060E-12 | 0.1000E+01 | 0.5000E+00 | 0.0000E+00 |
| 7 | 0.1017E+02 | 0.5369E+03 | 0.7658E+00 | 0.1499E+02 | 0.1000E+01 | 0.1001E-02 | -0.1079E-12 | 0.1000E+01 | 0.6000E+00 | 0.0000E+00 |
| 8 | 0.1017E+02 | 0.5369E+03 | 0.7660E+00 | 0.1499E+02 | 0.1000E+01 | 0.8796E-03 | -0.1077E-12 | 0.1000E+01 | 0.7000E+00 | 0.0000E+00 |
| 9 | 0.1016E+02 | 0.5368E+03 | 0.7662E+00 | 0.1499E+02 | 0.1000E+01 | 0.6578E-03 | -0.1078E-12 | 0.1000E+01 | 0.8000E+00 | 0.0000E+00 |
| 10 | 0.1016E+02 | 0.5368E+03 | 0.7663E+00 | 0.1499E+02 | 0.1000E+01 | 0.2440E-03 | -0.1065E-12 | 0.1000E+01 | 0.9000E+00 | 0.0000E+00 |
| 11 | 0.1016E+02 | 0.5368E+03 | 0.7663E+00 | 0.1499E+02 | 0.1000E+01 | 0.1976E-17 | -0.1073E-12 | 0.1000E+01 | 0.1000E+01 | 0.0000E+00 |

| BLOCK 1 VARIABLES AT L, J = 11, 9 | | | | ITERATION NUMBER: 2500 | | | | | | |
|-----------------------------------|------------|-------------|-------------|------------------------|------------|------------|-------------|------------|------------|------------|
| K | PRESSURE | TEMPERATURE | MACH NUMBER | TOTAL PRESS | U-COSINE | V-COSINE | W-COSINE | X | Y | Z |
| 1 | 0.1061E+02 | 0.5435E+03 | 0.7221E+00 | 0.1502E+02 | 0.1000E+01 | 0.6267E-16 | -0.2607E-12 | 0.2000E+01 | 0.0000E+00 | 0.0000E+00 |
| 2 | 0.1061E+02 | 0.5435E+03 | 0.7222E+00 | 0.1502E+02 | 0.1000E+01 | 0.7295E-02 | -0.2598E-12 | 0.2000E+01 | 0.1000E+00 | 0.0000E+00 |
| 3 | 0.1059E+02 | 0.5431E+03 | 0.7246E+00 | 0.1502E+02 | 0.9999E+00 | 0.1720E-01 | -0.2674E-12 | 0.2000E+01 | 0.2000E+00 | 0.0000E+00 |
| 4 | 0.1054E+02 | 0.5424E+03 | 0.7297E+00 | 0.1502E+02 | 0.9997E+00 | 0.2455E-01 | -0.2620E-12 | 0.2000E+01 | 0.3000E+00 | 0.0000E+00 |
| 5 | 0.1050E+02 | 0.5417E+03 | 0.7356E+00 | 0.1504E+02 | 0.9994E+00 | 0.3515E-01 | -0.2540E-12 | 0.2000E+01 | 0.4000E+00 | 0.0000E+00 |
| 6 | 0.1038E+02 | 0.5399E+03 | 0.7468E+00 | 0.1503E+02 | 0.9992E+00 | 0.4115E-01 | -0.2556E-12 | 0.2000E+01 | 0.5000E+00 | 0.0000E+00 |
| 7 | 0.1032E+02 | 0.5389E+03 | 0.7568E+00 | 0.1508E+02 | 0.9985E+00 | 0.5516E-01 | -0.2496E-12 | 0.2000E+01 | 0.6000E+00 | 0.0000E+00 |
| 8 | 0.1008E+02 | 0.5352E+03 | 0.7779E+00 | 0.1504E+02 | 0.9984E+00 | 0.5736E-01 | -0.1875E-12 | 0.2000E+01 | 0.7000E+00 | 0.0000E+00 |
| 9 | 0.1003E+02 | 0.5342E+03 | 0.7948E+00 | 0.1521E+02 | 0.9967E+00 | 0.8124E-01 | -0.1167E-12 | 0.2000E+01 | 0.8000E+00 | 0.0000E+00 |
| 10 | 0.9538E+01 | 0.5265E+03 | 0.8321E+00 | 0.1502E+02 | 0.9973E+00 | 0.7280E-01 | -0.2698E-12 | 0.2000E+01 | 0.9000E+00 | 0.0000E+00 |
| 11 | 0.9543E+01 | 0.5267E+03 | 0.8308E+00 | 0.1500E+02 | 0.9923E+00 | 0.1240E+00 | -0.2711E-12 | 0.2000E+01 | 0.1000E+01 | 0.0000E+00 |

| BLOCK 1 VARIABLES AT L, J = 11, 13 | | | | ITERATION NUMBER: 2500 | | | | | | |
|------------------------------------|------------|-------------|-------------|------------------------|------------|------------|-------------|------------|------------|------------|
| K | PRESSURE | TEMPERATURE | MACH NUMBER | TOTAL PRESS | U-COSINE | V-COSINE | W-COSINE | X | Y | Z |
| 1 | 0.1235E+02 | 0.5678E+03 | 0.5337E+00 | 0.1499E+02 | 0.1000E+01 | 0.2458E-15 | -0.4842E-12 | 0.3000E+01 | 0.0000E+00 | 0.0000E+00 |
| 2 | 0.1235E+02 | 0.5677E+03 | 0.5338E+00 | 0.1499E+02 | 0.9997E+00 | 0.2347E-01 | -0.4824E-12 | 0.3000E+01 | 0.1250E+00 | 0.0000E+00 |
| 3 | 0.1235E+02 | 0.5678E+03 | 0.5333E+00 | 0.1499E+02 | 0.9989E+00 | 0.4773E-01 | -0.4063E-12 | 0.3000E+01 | 0.2500E+00 | 0.0000E+00 |
| 4 | 0.1236E+02 | 0.5678E+03 | 0.5323E+00 | 0.1499E+02 | 0.9974E+00 | 0.7138E-01 | -0.4424E-12 | 0.3000E+01 | 0.3750E+00 | 0.0000E+00 |
| 5 | 0.1234E+02 | 0.5679E+03 | 0.5315E+00 | 0.1499E+02 | 0.9954E+00 | 0.9592E-01 | -0.4569E-12 | 0.3000E+01 | 0.5000E+00 | 0.0000E+00 |
| 6 | 0.1238E+02 | 0.5682E+03 | 0.5295E+00 | 0.1498E+02 | 0.9927E+00 | 0.1206E+00 | -0.4055E-12 | 0.3000E+01 | 0.6250E+00 | 0.0000E+00 |
| 7 | 0.1239E+02 | 0.5683E+03 | 0.5288E+00 | 0.1499E+02 | 0.9895E+00 | 0.1446E+00 | -0.3951E-12 | 0.3000E+01 | 0.7500E+00 | 0.0000E+00 |
| 8 | 0.1242E+02 | 0.5688E+03 | 0.5253E+00 | 0.1499E+02 | 0.9853E+00 | 0.1707E+00 | -0.6620E-12 | 0.3000E+01 | 0.8750E+00 | 0.0000E+00 |
| 9 | 0.1242E+02 | 0.5692E+03 | 0.5193E+00 | 0.1493E+02 | 0.9810E+00 | 0.1942E+00 | -0.9679E-12 | 0.3000E+01 | 0.1000E+01 | 0.0000E+00 |
| 10 | 0.1248E+02 | 0.5702E+03 | 0.5068E+00 | 0.1487E+02 | 0.9742E+00 | 0.2255E+00 | -0.4390E-12 | 0.3000E+01 | 0.1125E+01 | 0.0000E+00 |
| 11 | 0.1248E+02 | 0.5702E+03 | 0.5068E+00 | 0.1487E+02 | 0.9701E+00 | 0.2425E+00 | -0.4410E-12 | 0.3000E+01 | 0.1250E+01 | 0.0000E+00 |

Listing E-6. Continued

| BLOCK 1 VARIABLES AT L, J = 11, 17 | | | | ITERATION NUMBER: 2500 | | | | | | |
|------------------------------------|------------|-------------|-------------|------------------------|------------|-------------|-------------|------------|------------|------------|
| K | PRESSURE | TEMPERATURE | MACH NUMBER | TOTAL PRESS | U-COSINE | V-COSINE | W-COSINE | X | Y | Z |
| 1 | 0.1328E+02 | 0.5797E+03 | 0.4194E+00 | 0.1499E+02 | 0.1000E+01 | -0.4898E-15 | -0.5519E-12 | 0.4000E+01 | 0.0000E+00 | 0.0000E+00 |
| 2 | 0.1328E+02 | 0.5796E+03 | 0.4195E+00 | 0.1499E+02 | 0.9997E+00 | 0.2514E-01 | -0.5484E-12 | 0.4000E+01 | 0.1500E+00 | 0.0000E+00 |
| 3 | 0.1329E+02 | 0.5797E+03 | 0.4189E+00 | 0.1499E+02 | 0.9988E+00 | 0.4914E-01 | -0.4455E-12 | 0.4000E+01 | 0.3000E+00 | 0.0000E+00 |
| 4 | 0.1329E+02 | 0.5798E+03 | 0.4178E+00 | 0.1499E+02 | 0.9973E+00 | 0.7406E-01 | -0.4533E-12 | 0.4000E+01 | 0.4500E+00 | 0.0000E+00 |
| 5 | 0.1330E+02 | 0.5799E+03 | 0.4164E+00 | 0.1499E+02 | 0.9952E+00 | 0.9788E-01 | -0.4150E-12 | 0.4000E+01 | 0.6000E+00 | 0.0000E+00 |
| 6 | 0.1332E+02 | 0.5801E+03 | 0.4150E+00 | 0.1499E+02 | 0.9924E+00 | 0.1228E+00 | -0.3794E-12 | 0.4000E+01 | 0.7500E+00 | 0.0000E+00 |
| 7 | 0.1333E+02 | 0.5803E+03 | 0.4129E+00 | 0.1498E+02 | 0.9893E+00 | 0.1460E+00 | -0.5875E-12 | 0.4000E+01 | 0.9000E+00 | 0.0000E+00 |
| 8 | 0.1335E+02 | 0.5807E+03 | 0.4081E+00 | 0.1497E+02 | 0.9851E+00 | 0.1721E+00 | -0.1077E-11 | 0.4000E+01 | 0.1050E+01 | 0.0000E+00 |
| 9 | 0.1336E+02 | 0.5811E+03 | 0.4010E+00 | 0.1492E+02 | 0.9807E+00 | 0.1955E+00 | -0.1336E-11 | 0.4000E+01 | 0.1200E+01 | 0.0000E+00 |
| 10 | 0.1339E+02 | 0.5817E+03 | 0.3956E+00 | 0.1492E+02 | 0.9750E+00 | 0.2223E+00 | -0.5653E-12 | 0.4000E+01 | 0.1350E+01 | 0.0000E+00 |
| 11 | 0.1339E+02 | 0.5817E+03 | 0.3955E+00 | 0.1492E+02 | 0.9701E+00 | 0.2425E+00 | -0.5666E-12 | 0.4000E+01 | 0.1500E+01 | 0.0000E+00 |

| BLOCK 1 VARIABLES AT L, J = 11, 21 | | | | ITERATION NUMBER: 2500 | | | | | | |
|------------------------------------|------------|-------------|-------------|------------------------|------------|------------|-------------|------------|------------|------------|
| K | PRESSURE | TEMPERATURE | MACH NUMBER | TOTAL PRESS | U-COSINE | V-COSINE | W-COSINE | X | Y | Z |
| 1 | 0.1376E+02 | 0.5856E+03 | 0.3509E+00 | 0.1499E+02 | 0.1000E+01 | 0.0000E+00 | -0.5244E-12 | 0.5000E+01 | 0.0000E+00 | 0.0000E+00 |
| 2 | 0.1376E+02 | 0.5856E+03 | 0.3510E+00 | 0.1499E+02 | 0.9997E+00 | 0.2307E-01 | -0.5217E-12 | 0.5000E+01 | 0.1750E+00 | 0.0000E+00 |
| 3 | 0.1377E+02 | 0.5856E+03 | 0.3505E+00 | 0.1499E+02 | 0.9990E+00 | 0.4510E-01 | -0.3519E-12 | 0.5000E+01 | 0.3500E+00 | 0.0000E+00 |
| 4 | 0.1378E+02 | 0.5857E+03 | 0.3493E+00 | 0.1499E+02 | 0.9977E+00 | 0.6807E-01 | -0.2805E-12 | 0.5000E+01 | 0.5250E+00 | 0.0000E+00 |
| 5 | 0.1379E+02 | 0.5858E+03 | 0.3477E+00 | 0.1499E+02 | 0.9959E+00 | 0.9017E-01 | -0.2248E-12 | 0.5000E+01 | 0.7000E+00 | 0.0000E+00 |
| 6 | 0.1381E+02 | 0.5861E+03 | 0.3455E+00 | 0.1499E+02 | 0.9935E+00 | 0.1138E+00 | -0.3366E-12 | 0.5000E+01 | 0.8750E+00 | 0.0000E+00 |
| 7 | 0.1382E+02 | 0.5863E+03 | 0.3417E+00 | 0.1498E+02 | 0.9906E+00 | 0.1370E+00 | -0.7983E-12 | 0.5000E+01 | 0.1050E+01 | 0.0000E+00 |
| 8 | 0.1384E+02 | 0.5868E+03 | 0.3356E+00 | 0.1497E+02 | 0.9866E+00 | 0.1634E+00 | -0.1421E-11 | 0.5000E+01 | 0.1225E+01 | 0.0000E+00 |
| 9 | 0.1385E+02 | 0.5871E+03 | 0.3292E+00 | 0.1493E+02 | 0.9821E+00 | 0.1883E+00 | -0.1589E-11 | 0.5000E+01 | 0.1400E+01 | 0.0000E+00 |
| 10 | 0.1389E+02 | 0.5877E+03 | 0.3249E+00 | 0.1494E+02 | 0.9761E+00 | 0.2172E+00 | -0.6202E-12 | 0.5000E+01 | 0.1575E+01 | 0.0000E+00 |
| 11 | 0.1389E+02 | 0.5877E+03 | 0.3248E+00 | 0.1494E+02 | 0.9701E+00 | 0.2425E+00 | -0.6250E-12 | 0.5000E+01 | 0.1750E+01 | 0.0000E+00 |

| BLOCK 1 VARIABLES AT L, J = 11, 25 | | | | ITERATION NUMBER: 2500 | | | | | | |
|------------------------------------|------------|-------------|-------------|------------------------|------------|------------|-------------|------------|------------|------------|
| K | PRESSURE | TEMPERATURE | MACH NUMBER | TOTAL PRESS | U-COSINE | V-COSINE | W-COSINE | X | Y | Z |
| 1 | 0.1401E+02 | 0.5886E+03 | 0.3113E+00 | 0.1499E+02 | 0.1000E+01 | 0.0000E+00 | -0.3430E-12 | 0.6000E+01 | 0.0000E+00 | 0.0000E+00 |
| 2 | 0.1401E+02 | 0.5886E+03 | 0.3114E+00 | 0.1499E+02 | 0.9999E+00 | 0.1559E-01 | -0.3438E-12 | 0.6000E+01 | 0.2000E+00 | 0.0000E+00 |
| 3 | 0.1402E+02 | 0.5886E+03 | 0.3106E+00 | 0.1499E+02 | 0.9996E+00 | 0.2958E-01 | -0.1441E-12 | 0.6000E+01 | 0.4000E+00 | 0.0000E+00 |
| 4 | 0.1403E+02 | 0.5888E+03 | 0.3088E+00 | 0.1499E+02 | 0.9990E+00 | 0.4462E-01 | 0.1036E-13 | 0.6000E+01 | 0.6000E+00 | 0.0000E+00 |
| 5 | 0.1405E+02 | 0.5890E+03 | 0.3058E+00 | 0.1499E+02 | 0.9983E+00 | 0.5805E-01 | -0.1211E-13 | 0.6000E+01 | 0.8000E+00 | 0.0000E+00 |
| 6 | 0.1408E+02 | 0.5894E+03 | 0.3009E+00 | 0.1499E+02 | 0.9973E+00 | 0.7364E-01 | -0.3558E-12 | 0.6000E+01 | 0.1000E+01 | 0.0000E+00 |
| 7 | 0.1410E+02 | 0.5897E+03 | 0.2933E+00 | 0.1497E+02 | 0.9963E+00 | 0.8615E-01 | -0.1030E-11 | 0.6000E+01 | 0.1200E+01 | 0.0000E+00 |
| 8 | 0.1416E+02 | 0.5906E+03 | 0.2821E+00 | 0.1496E+02 | 0.9945E+00 | 0.1051E+00 | -0.1673E-11 | 0.6000E+01 | 0.1400E+01 | 0.0000E+00 |
| 9 | 0.1417E+02 | 0.5910E+03 | 0.2691E+00 | 0.1491E+02 | 0.9934E+00 | 0.1147E+00 | -0.1656E-11 | 0.6000E+01 | 0.1600E+01 | 0.0000E+00 |
| 10 | 0.1430E+02 | 0.5926E+03 | 0.2553E+00 | 0.1497E+02 | 0.9895E+00 | 0.1447E+00 | -0.8511E-12 | 0.6000E+01 | 0.1800E+01 | 0.0000E+00 |
| 11 | 0.1430E+02 | 0.5926E+03 | 0.2553E+00 | 0.1497E+02 | 0.9923E+00 | 0.1240E+00 | -0.8580E-12 | 0.6000E+01 | 0.2000E+01 | 0.0000E+00 |

| BLOCK 1 VARIABLES AT L, J = 11, 29 | | | | ITERATION NUMBER: 2500 | | | | | | |
|------------------------------------|------------|-------------|-------------|------------------------|------------|------------|-------------|------------|------------|------------|
| K | PRESSURE | TEMPERATURE | MACH NUMBER | TOTAL PRESS | U-COSINE | V-COSINE | W-COSINE | X | Y | Z |
| 1 | 0.1410E+02 | 0.5896E+03 | 0.2962E+00 | 0.1499E+02 | 0.1000E+01 | 0.0000E+00 | -0.9084E-13 | 0.7000E+01 | 0.0000E+00 | 0.0000E+00 |
| 2 | 0.1410E+02 | 0.5896E+03 | 0.2962E+00 | 0.1499E+02 | 0.1000E+01 | 0.5157E-02 | -0.9136E-13 | 0.7000E+01 | 0.2000E+00 | 0.0000E+00 |
| 3 | 0.1411E+02 | 0.5897E+03 | 0.2962E+00 | 0.1499E+02 | 0.1000E+01 | 0.9243E-02 | 0.1809E-13 | 0.7000E+01 | 0.4000E+00 | 0.0000E+00 |
| 4 | 0.1411E+02 | 0.5897E+03 | 0.2957E+00 | 0.1499E+02 | 0.9999E+00 | 0.1354E-01 | 0.1439E-12 | 0.7000E+01 | 0.6000E+00 | 0.0000E+00 |
| 5 | 0.1412E+02 | 0.5898E+03 | 0.2945E+00 | 0.1499E+02 | 0.9999E+00 | 0.1607E-01 | 0.1095E-12 | 0.7000E+01 | 0.8000E+00 | 0.0000E+00 |
| 6 | 0.1413E+02 | 0.5900E+03 | 0.2920E+00 | 0.1499E+02 | 0.9998E+00 | 0.1871E-01 | -0.2183E-12 | 0.7000E+01 | 0.1000E+01 | 0.0000E+00 |
| 7 | 0.1413E+02 | 0.5902E+03 | 0.2874E+00 | 0.1497E+02 | 0.9998E+00 | 0.1923E-01 | -0.7282E-12 | 0.7000E+01 | 0.1200E+01 | 0.0000E+00 |
| 8 | 0.1415E+02 | 0.5905E+03 | 0.2824E+00 | 0.1495E+02 | 0.9998E+00 | 0.1898E-01 | -0.1125E-11 | 0.7000E+01 | 0.1400E+01 | 0.0000E+00 |
| 9 | 0.1415E+02 | 0.5907E+03 | 0.2789E+00 | 0.1494E+02 | 0.9999E+00 | 0.1299E-01 | -0.1210E-11 | 0.7000E+01 | 0.1600E+01 | 0.0000E+00 |
| 10 | 0.1416E+02 | 0.5909E+03 | 0.2799E+00 | 0.1496E+02 | 0.1000E+01 | 0.4977E-02 | -0.1126E-11 | 0.7000E+01 | 0.1800E+01 | 0.0000E+00 |
| 11 | 0.1416E+02 | 0.5909E+03 | 0.2799E+00 | 0.1496E+02 | 0.1000E+01 | 0.6513E-16 | -0.1134E-11 | 0.7000E+01 | 0.2000E+01 | 0.0000E+00 |

Listing E-6. Continued

| BLOCK 1 VARIABLES AT L, J = 11, 33 | | | | ITERATION NUMBER: 2500 | | | | | | |
|------------------------------------|------------|-------------|-------------|------------------------|------------|------------|-------------|------------|------------|------------|
| K | PRESSURE | TEMPERATURE | MACH NUMBER | TOTAL PRESS | U-COSINE | V-COSINE | W-COSINE | X | Y | Z |
| 1 | 0.1413E+02 | 0.5902E+03 | 0.2924E+00 | 0.1499E+02 | 0.1000E+01 | 0.0000E+00 | 0.2763E-13 | 0.8000E+01 | 0.0000E+00 | 0.0000E+00 |
| 2 | 0.1413E+02 | 0.5902E+03 | 0.2924E+00 | 0.1499E+02 | 0.1000E+01 | 0.1663E-02 | 0.2763E-13 | 0.8000E+01 | 0.2000E+00 | 0.0000E+00 |
| 3 | 0.1413E+02 | 0.5901E+03 | 0.2928E+00 | 0.1500E+02 | 0.1000E+01 | 0.2958E-02 | 0.1099E-12 | 0.8000E+01 | 0.4000E+00 | 0.0000E+00 |
| 4 | 0.1413E+02 | 0.5901E+03 | 0.2930E+00 | 0.1500E+02 | 0.1000E+01 | 0.4263E-02 | 0.1837E-12 | 0.8000E+01 | 0.6000E+00 | 0.0000E+00 |
| 5 | 0.1413E+02 | 0.5900E+03 | 0.2926E+00 | 0.1499E+02 | 0.1000E+01 | 0.5022E-02 | 0.1126E-12 | 0.8000E+01 | 0.8000E+00 | 0.0000E+00 |
| 6 | 0.1413E+02 | 0.5900E+03 | 0.2910E+00 | 0.1499E+02 | 0.1000E+01 | 0.5691E-02 | -0.1946E-12 | 0.8000E+01 | 0.1000E+01 | 0.0000E+00 |
| 7 | 0.1413E+02 | 0.5900E+03 | 0.2881E+00 | 0.1497E+02 | 0.1000E+01 | 0.5692E-02 | -0.6308E-12 | 0.8000E+01 | 0.1200E+01 | 0.0000E+00 |
| 8 | 0.1413E+02 | 0.5901E+03 | 0.2854E+00 | 0.1495E+02 | 0.1000E+01 | 0.4846E-02 | -0.9990E-12 | 0.8000E+01 | 0.1400E+01 | 0.0000E+00 |
| 9 | 0.1413E+02 | 0.5902E+03 | 0.2839E+00 | 0.1494E+02 | 0.1000E+01 | 0.3008E-02 | -0.1164E-11 | 0.8000E+01 | 0.1600E+01 | 0.0000E+00 |
| 10 | 0.1413E+02 | 0.5903E+03 | 0.2840E+00 | 0.1494E+02 | 0.1000E+01 | 0.9903E-03 | -0.1185E-11 | 0.8000E+01 | 0.1800E+01 | 0.0000E+00 |
| 11 | 0.1413E+02 | 0.5903E+03 | 0.2840E+00 | 0.1494E+02 | 0.1000E+01 | 0.8039E-17 | -0.1185E-11 | 0.8000E+01 | 0.2000E+01 | 0.0000E+00 |

| BLOCK 1 VARIABLES AT L, K = 11, 2 | | | | ITERATION NUMBER: 2500 | | | | | | |
|-----------------------------------|------------|-------------|-------------|------------------------|------------|-------------|-------------|------------|------------|------------|
| J | PRESSURE | TEMPERATURE | MACH NUMBER | TOTAL PRESS | U-COSINE | V-COSINE | W-COSINE | X | Y | Z |
| 2 | 0.1018E+02 | 0.5371E+03 | 0.7657E+00 | 0.1500E+02 | 0.1000E+01 | -0.3825E-05 | -0.2589E-13 | 0.2500E+00 | 0.1000E+00 | 0.0000E+00 |
| 4 | 0.1018E+02 | 0.5371E+03 | 0.7654E+00 | 0.1500E+02 | 0.1000E+01 | 0.2894E-04 | -0.7965E-13 | 0.7500E+00 | 0.1000E+00 | 0.0000E+00 |
| 6 | 0.1021E+02 | 0.5375E+03 | 0.7627E+00 | 0.1501E+02 | 0.1000E+01 | 0.4512E-03 | -0.1368E-12 | 0.1250E+01 | 0.1000E+00 | 0.0000E+00 |
| 8 | 0.1038E+02 | 0.5400E+03 | 0.7454E+00 | 0.1500E+02 | 0.1000E+01 | 0.3524E-02 | -0.2202E-12 | 0.1750E+01 | 0.1000E+00 | 0.0000E+00 |
| 10 | 0.1099E+02 | 0.5490E+03 | 0.6809E+00 | 0.1498E+02 | 0.9999E+00 | 0.1377E-01 | -0.3191E-12 | 0.2250E+01 | 0.1062E+00 | 0.0000E+00 |
| 12 | 0.1199E+02 | 0.5629E+03 | 0.5747E+00 | 0.1499E+02 | 0.9998E+00 | 0.2165E-01 | -0.4515E-12 | 0.2750E+01 | 0.1187E+00 | 0.0000E+00 |
| 14 | 0.1265E+02 | 0.5716E+03 | 0.4990E+00 | 0.1499E+02 | 0.9997E+00 | 0.2454E-01 | -0.5090E-12 | 0.3250E+01 | 0.1312E+00 | 0.0000E+00 |
| 16 | 0.1310E+02 | 0.5774E+03 | 0.4425E+00 | 0.1499E+02 | 0.9997E+00 | 0.2521E-01 | -0.5420E-12 | 0.3750E+01 | 0.1437E+00 | 0.0000E+00 |
| 18 | 0.1343E+02 | 0.5815E+03 | 0.3992E+00 | 0.1499E+02 | 0.9997E+00 | 0.2493E-01 | -0.5514E-12 | 0.4250E+01 | 0.1562E+00 | 0.0000E+00 |
| 20 | 0.1367E+02 | 0.5844E+03 | 0.3652E+00 | 0.1499E+02 | 0.9997E+00 | 0.2396E-01 | -0.5357E-12 | 0.4750E+01 | 0.1687E+00 | 0.0000E+00 |
| 22 | 0.1384E+02 | 0.5865E+03 | 0.3386E+00 | 0.1499E+02 | 0.9998E+00 | 0.2192E-01 | -0.5017E-12 | 0.5250E+01 | 0.1812E+00 | 0.0000E+00 |

| BLOCK 1 VARIABLES AT L, K = 11, 4 | | | | ITERATION NUMBER: 2500 | | | | | | |
|-----------------------------------|------------|-------------|-------------|------------------------|------------|-------------|-------------|------------|------------|------------|
| J | PRESSURE | TEMPERATURE | MACH NUMBER | TOTAL PRESS | U-COSINE | V-COSINE | W-COSINE | X | Y | Z |
| 2 | 0.1018E+02 | 0.5371E+03 | 0.7657E+00 | 0.1500E+02 | 0.1000E+01 | -0.9022E-05 | -0.2630E-13 | 0.2500E+00 | 0.3000E+00 | 0.0000E+00 |
| 4 | 0.1018E+02 | 0.5371E+03 | 0.7655E+00 | 0.1500E+02 | 0.1000E+01 | 0.8320E-04 | -0.8003E-13 | 0.7500E+00 | 0.3000E+00 | 0.0000E+00 |
| 6 | 0.1020E+02 | 0.5374E+03 | 0.7637E+00 | 0.1501E+02 | 0.1000E+01 | 0.1306E-02 | -0.1366E-12 | 0.1250E+01 | 0.3000E+00 | 0.0000E+00 |
| 8 | 0.1033E+02 | 0.5394E+03 | 0.7498E+00 | 0.1500E+02 | 0.9999E+00 | 0.1081E-01 | -0.2189E-12 | 0.1750E+01 | 0.3000E+00 | 0.0000E+00 |
| 10 | 0.1091E+02 | 0.5479E+03 | 0.6868E+00 | 0.1496E+02 | 0.9989E+00 | 0.4715E-01 | -0.3158E-12 | 0.2250E+01 | 0.3187E+00 | 0.0000E+00 |
| 12 | 0.1199E+02 | 0.5630E+03 | 0.5737E+00 | 0.1499E+02 | 0.9977E+00 | 0.6789E-01 | -0.4130E-12 | 0.2750E+01 | 0.3562E+00 | 0.0000E+00 |
| 14 | 0.1266E+02 | 0.5717E+03 | 0.4972E+00 | 0.1499E+02 | 0.9973E+00 | 0.7332E-01 | -0.4615E-12 | 0.3250E+01 | 0.3937E+00 | 0.0000E+00 |
| 16 | 0.1312E+02 | 0.5776E+03 | 0.4407E+00 | 0.1499E+02 | 0.9972E+00 | 0.7433E-01 | -0.4682E-12 | 0.3750E+01 | 0.4312E+00 | 0.0000E+00 |
| 18 | 0.1344E+02 | 0.5816E+03 | 0.3975E+00 | 0.1499E+02 | 0.9973E+00 | 0.7347E-01 | -0.4274E-12 | 0.4250E+01 | 0.4687E+00 | 0.0000E+00 |
| 20 | 0.1368E+02 | 0.5846E+03 | 0.3635E+00 | 0.1499E+02 | 0.9975E+00 | 0.7075E-01 | -0.3366E-12 | 0.4750E+01 | 0.5062E+00 | 0.0000E+00 |
| 22 | 0.1386E+02 | 0.5867E+03 | 0.3367E+00 | 0.1499E+02 | 0.9979E+00 | 0.6469E-01 | -0.2154E-12 | 0.5250E+01 | 0.5437E+00 | 0.0000E+00 |

| BLOCK 1 VARIABLES AT L, K = 11, 6 | | | | ITERATION NUMBER: 2500 | | | | | | |
|-----------------------------------|------------|-------------|-------------|------------------------|------------|-------------|-------------|------------|------------|------------|
| J | PRESSURE | TEMPERATURE | MACH NUMBER | TOTAL PRESS | U-COSINE | V-COSINE | W-COSINE | X | Y | Z |
| 2 | 0.1018E+02 | 0.5371E+03 | 0.7658E+00 | 0.1500E+02 | 0.1000E+01 | -0.1333E-04 | -0.2500E-13 | 0.2500E+00 | 0.5000E+00 | 0.0000E+00 |
| 4 | 0.1018E+02 | 0.5371E+03 | 0.7658E+00 | 0.1501E+02 | 0.1000E+01 | 0.8197E-04 | -0.7885E-13 | 0.7500E+00 | 0.5000E+00 | 0.0000E+00 |
| 6 | 0.1018E+02 | 0.5372E+03 | 0.7656E+00 | 0.1501E+02 | 0.1000E+01 | 0.1558E-02 | -0.1385E-12 | 0.1250E+01 | 0.5000E+00 | 0.0000E+00 |
| 8 | 0.1025E+02 | 0.5381E+03 | 0.7593E+00 | 0.1502E+02 | 0.9999E+00 | 0.1532E-01 | -0.2161E-12 | 0.1750E+01 | 0.5000E+00 | 0.0000E+00 |
| 10 | 0.1076E+02 | 0.5458E+03 | 0.6993E+00 | 0.1492E+02 | 0.9965E+00 | 0.8331E-01 | -0.3192E-12 | 0.2250E+01 | 0.5312E+00 | 0.0000E+00 |
| 12 | 0.1200E+02 | 0.5632E+03 | 0.5715E+00 | 0.1498E+02 | 0.9932E+00 | 0.1160E+00 | -0.3996E-12 | 0.2750E+01 | 0.5937E+00 | 0.0000E+00 |
| 14 | 0.1268E+02 | 0.5721E+03 | 0.4942E+00 | 0.1499E+02 | 0.9924E+00 | 0.1228E+00 | -0.4026E-12 | 0.3250E+01 | 0.6562E+00 | 0.0000E+00 |
| 16 | 0.1314E+02 | 0.5779E+03 | 0.4378E+00 | 0.1499E+02 | 0.9924E+00 | 0.1234E+00 | -0.3883E-12 | 0.3750E+01 | 0.7187E+00 | 0.0000E+00 |
| 18 | 0.1347E+02 | 0.5819E+03 | 0.3947E+00 | 0.1499E+02 | 0.9926E+00 | 0.1218E+00 | -0.3640E-12 | 0.4250E+01 | 0.7812E+00 | 0.0000E+00 |
| 20 | 0.1371E+02 | 0.5849E+03 | 0.3602E+00 | 0.1499E+02 | 0.9930E+00 | 0.1178E+00 | -0.3405E-12 | 0.4750E+01 | 0.8437E+00 | 0.0000E+00 |
| 22 | 0.1389E+02 | 0.5871E+03 | 0.3320E+00 | 0.1499E+02 | 0.9941E+00 | 0.1089E+00 | -0.3258E-12 | 0.5250E+01 | 0.9062E+00 | 0.0000E+00 |

Listing E-6. Continued

| BLOCK 1 VARIABLES AT L, K = 11, 8 | | | | ITERATION NUMBER: 2500 | | | | | | |
|-----------------------------------|------------|-------------|-------------|------------------------|------------|-------------|-------------|------------|------------|------------|
| J | PRESSURE | TEMPERATURE | MACH NUMBER | TOTAL PRESS | U-COSINE | V-COSINE | W-COSINE | X | Y | Z |
| 2 | 0.1018E+02 | 0.5370E+03 | 0.7658E+00 | 0.1500E+02 | 0.1000E+01 | -0.1300E-04 | -0.2643E-13 | 0.2500E+00 | 0.7000E+00 | 0.0000E+00 |
| 4 | 0.1018E+02 | 0.5370E+03 | 0.7661E+00 | 0.1501E+02 | 0.1000E+01 | 0.3645E-04 | -0.7786E-13 | 0.7500E+00 | 0.7000E+00 | 0.0000E+00 |
| 6 | 0.1017E+02 | 0.5369E+03 | 0.7681E+00 | 0.1502E+02 | 0.1000E+01 | 0.1018E-02 | -0.1386E-12 | 0.1250E+01 | 0.7000E+00 | 0.0000E+00 |
| 8 | 0.1011E+02 | 0.5360E+03 | 0.7751E+00 | 0.1504E+02 | 0.9999E+00 | 0.1426E-01 | -0.2302E-12 | 0.1750E+01 | 0.7000E+00 | 0.0000E+00 |
| 10 | 0.1052E+02 | 0.5424E+03 | 0.7186E+00 | 0.1484E+02 | 0.9921E+00 | 0.1251E+00 | -0.2399E-12 | 0.2250E+01 | 0.7437E+00 | 0.0000E+00 |
| 12 | 0.1205E+02 | 0.5640E+03 | 0.5677E+00 | 0.1499E+02 | 0.9861E+00 | 0.1663E+00 | -0.5484E-12 | 0.2750E+01 | 0.8312E+00 | 0.0000E+00 |
| 14 | 0.1272E+02 | 0.5728E+03 | 0.4891E+00 | 0.1498E+02 | 0.9850E+00 | 0.1725E+00 | -0.7722E-12 | 0.3250E+01 | 0.9187E+00 | 0.0000E+00 |
| 16 | 0.1318E+02 | 0.5786E+03 | 0.4314E+00 | 0.1498E+02 | 0.9850E+00 | 0.1727E+00 | -0.9823E-12 | 0.3750E+01 | 0.1006E+01 | 0.0000E+00 |
| 18 | 0.1350E+02 | 0.5826E+03 | 0.3872E+00 | 0.1497E+02 | 0.9852E+00 | 0.1712E+00 | -0.1172E-11 | 0.4250E+01 | 0.1094E+01 | 0.0000E+00 |
| 20 | 0.1374E+02 | 0.5855E+03 | 0.3513E+00 | 0.1496E+02 | 0.9859E+00 | 0.1675E+00 | -0.1337E-11 | 0.4750E+01 | 0.1181E+01 | 0.0000E+00 |
| 22 | 0.1393E+02 | 0.5879E+03 | 0.3205E+00 | 0.1496E+02 | 0.9874E+00 | 0.1585E+00 | -0.1492E-11 | 0.5250E+01 | 0.1269E+01 | 0.0000E+00 |

| BLOCK 1 VARIABLES AT L, K = 11, 10 | | | | ITERATION NUMBER: 2500 | | | | | | |
|------------------------------------|------------|-------------|-------------|------------------------|------------|-------------|-------------|------------|------------|------------|
| J | PRESSURE | TEMPERATURE | MACH NUMBER | TOTAL PRESS | U-COSINE | V-COSINE | W-COSINE | X | Y | Z |
| 2 | 0.1018E+02 | 0.5370E+03 | 0.7659E+00 | 0.1500E+02 | 0.1000E+01 | -0.7830E-05 | -0.2406E-13 | 0.2500E+00 | 0.9000E+00 | 0.0000E+00 |
| 4 | 0.1018E+02 | 0.5370E+03 | 0.7663E+00 | 0.1501E+02 | 0.1000E+01 | 0.7429E-05 | -0.7726E-13 | 0.7500E+00 | 0.9000E+00 | 0.0000E+00 |
| 6 | 0.1015E+02 | 0.5366E+03 | 0.7701E+00 | 0.1503E+02 | 0.1000E+01 | 0.1337E-03 | -0.1372E-12 | 0.1250E+01 | 0.9000E+00 | 0.0000E+00 |
| 8 | 0.9885E+01 | 0.5326E+03 | 0.8034E+00 | 0.1512E+02 | 0.1000E+01 | 0.1694E-02 | -0.2087E-12 | 0.1750E+01 | 0.9000E+00 | 0.0000E+00 |
| 10 | 0.1016E+02 | 0.5380E+03 | 0.7351E+00 | 0.1455E+02 | 0.9842E+00 | 0.1770E+00 | -0.3180E-12 | 0.2250E+01 | 0.9562E+00 | 0.0000E+00 |
| 12 | 0.1213E+02 | 0.5657E+03 | 0.5669E+00 | 0.1487E+02 | 0.9747E+00 | 0.2234E+00 | -0.3848E-12 | 0.2750E+01 | 0.1069E+01 | 0.0000E+00 |
| 14 | 0.1278E+02 | 0.5741E+03 | 0.4720E+00 | 0.1489E+02 | 0.9743E+00 | 0.2253E+00 | -0.4766E-12 | 0.3250E+01 | 0.1181E+01 | 0.0000E+00 |
| 16 | 0.1323E+02 | 0.5797E+03 | 0.4177E+00 | 0.1491E+02 | 0.9748E+00 | 0.2232E+00 | -0.5402E-12 | 0.3750E+01 | 0.1294E+01 | 0.0000E+00 |
| 18 | 0.1354E+02 | 0.5835E+03 | 0.3757E+00 | 0.1492E+02 | 0.9752E+00 | 0.2215E+00 | -0.5878E-12 | 0.4250E+01 | 0.1406E+01 | 0.0000E+00 |
| 20 | 0.1378E+02 | 0.5864E+03 | 0.3406E+00 | 0.1493E+02 | 0.9756E+00 | 0.2195E+00 | -0.6111E-12 | 0.4750E+01 | 0.1519E+01 | 0.0000E+00 |
| 22 | 0.1398E+02 | 0.5888E+03 | 0.3086E+00 | 0.1493E+02 | 0.9767E+00 | 0.2144E+00 | -0.6250E-12 | 0.5250E+01 | 0.1631E+01 | 0.0000E+00 |

| BLOCK 1 VARIABLES AT K, J = 4, 10 | | | | ITERATION NUMBER: 2500 | | | | | | |
|-----------------------------------|------------|-------------|-------------|------------------------|------------|------------|-------------|------------|------------|-------------|
| L | PRESSURE | TEMPERATURE | MACH NUMBER | TOTAL PRESS | U-COSINE | V-COSINE | W-COSINE | X | Y | Z |
| 1 | 0.1091E+02 | 0.5479E+03 | 0.6868E+00 | 0.1496E+02 | 0.9989E+00 | 0.4715E-01 | 0.0000E+00 | 0.2250E+01 | 0.3187E+00 | -0.2500E+01 |
| 2 | 0.1091E+02 | 0.5479E+03 | 0.6868E+00 | 0.1496E+02 | 0.9989E+00 | 0.4715E-01 | 0.2429E-08 | 0.2250E+01 | 0.3187E+00 | -0.2250E+01 |
| 3 | 0.1091E+02 | 0.5479E+03 | 0.6868E+00 | 0.1496E+02 | 0.9989E+00 | 0.4715E-01 | 0.1172E-08 | 0.2250E+01 | 0.3187E+00 | -0.2000E+01 |
| 4 | 0.1091E+02 | 0.5479E+03 | 0.6868E+00 | 0.1496E+02 | 0.9989E+00 | 0.4715E-01 | 0.1594E-08 | 0.2250E+01 | 0.3187E+00 | -0.1750E+01 |
| 5 | 0.1091E+02 | 0.5479E+03 | 0.6868E+00 | 0.1496E+02 | 0.9989E+00 | 0.4715E-01 | 0.9666E-09 | 0.2250E+01 | 0.3187E+00 | -0.1500E+01 |
| 6 | 0.1091E+02 | 0.5479E+03 | 0.6868E+00 | 0.1496E+02 | 0.9989E+00 | 0.4715E-01 | 0.8261E-09 | 0.2250E+01 | 0.3187E+00 | -0.1250E+01 |
| 7 | 0.1091E+02 | 0.5479E+03 | 0.6868E+00 | 0.1496E+02 | 0.9989E+00 | 0.4715E-01 | 0.6269E-09 | 0.2250E+01 | 0.3187E+00 | -0.1000E+01 |
| 8 | 0.1091E+02 | 0.5479E+03 | 0.6868E+00 | 0.1496E+02 | 0.9989E+00 | 0.4715E-01 | 0.4785E-09 | 0.2250E+01 | 0.3187E+00 | -0.7500E+00 |
| 9 | 0.1091E+02 | 0.5479E+03 | 0.6868E+00 | 0.1496E+02 | 0.9989E+00 | 0.4715E-01 | 0.3157E-09 | 0.2250E+01 | 0.3187E+00 | -0.5000E+00 |
| 10 | 0.1091E+02 | 0.5479E+03 | 0.6868E+00 | 0.1496E+02 | 0.9989E+00 | 0.4715E-01 | 0.1561E-09 | 0.2250E+01 | 0.3187E+00 | -0.2500E+00 |
| 11 | 0.1091E+02 | 0.5479E+03 | 0.6868E+00 | 0.1496E+02 | 0.9989E+00 | 0.4715E-01 | -0.3158E-12 | 0.2250E+01 | 0.3187E+00 | 0.0000E+00 |
| 12 | 0.1091E+02 | 0.5479E+03 | 0.6868E+00 | 0.1496E+02 | 0.9989E+00 | 0.4715E-01 | -0.1568E-09 | 0.2250E+01 | 0.3187E+00 | 0.2500E+00 |
| 13 | 0.1091E+02 | 0.5479E+03 | 0.6868E+00 | 0.1496E+02 | 0.9989E+00 | 0.4715E-01 | -0.3163E-09 | 0.2250E+01 | 0.3187E+00 | 0.5000E+00 |
| 14 | 0.1091E+02 | 0.5479E+03 | 0.6868E+00 | 0.1496E+02 | 0.9989E+00 | 0.4715E-01 | -0.4792E-09 | 0.2250E+01 | 0.3187E+00 | 0.7500E+00 |
| 15 | 0.1091E+02 | 0.5479E+03 | 0.6868E+00 | 0.1496E+02 | 0.9989E+00 | 0.4715E-01 | -0.6276E-09 | 0.2250E+01 | 0.3187E+00 | 0.1000E+01 |
| 16 | 0.1091E+02 | 0.5479E+03 | 0.6868E+00 | 0.1496E+02 | 0.9989E+00 | 0.4715E-01 | -0.8268E-09 | 0.2250E+01 | 0.3187E+00 | 0.1250E+01 |
| 17 | 0.1091E+02 | 0.5479E+03 | 0.6868E+00 | 0.1496E+02 | 0.9989E+00 | 0.4715E-01 | -0.9673E-09 | 0.2250E+01 | 0.3187E+00 | 0.1500E+01 |
| 18 | 0.1091E+02 | 0.5479E+03 | 0.6868E+00 | 0.1496E+02 | 0.9989E+00 | 0.4715E-01 | -0.1594E-08 | 0.2250E+01 | 0.3187E+00 | 0.1750E+01 |
| 19 | 0.1091E+02 | 0.5479E+03 | 0.6868E+00 | 0.1496E+02 | 0.9989E+00 | 0.4715E-01 | -0.1173E-08 | 0.2250E+01 | 0.3187E+00 | 0.2000E+01 |
| 20 | 0.1091E+02 | 0.5479E+03 | 0.6868E+00 | 0.1496E+02 | 0.9989E+00 | 0.4715E-01 | -0.2429E-08 | 0.2250E+01 | 0.3187E+00 | 0.2250E+01 |
| 21 | 0.1091E+02 | 0.5479E+03 | 0.6868E+00 | 0.1496E+02 | 0.9989E+00 | 0.4715E-01 | 0.0000E+00 | 0.2250E+01 | 0.3187E+00 | 0.2500E+01 |

Listing E-6. Continued

| BLOCK 1 VARIABLES AT K, J = 4, 20 | | | | ITERATION NUMBER: 2500 | | | | | | |
|-----------------------------------|------------|-------------|-------------|------------------------|------------|------------|-------------|------------|------------|-------------|
| L | PRESSURE | TEMPERATURE | MACH NUMBER | TOTAL PRESS | U-COSINE | V-COSINE | W-COSINE | X | Y | Z |
| 1 | 0.1368E+02 | 0.5846E+03 | 0.3635E+00 | 0.1499E+02 | 0.9975E+00 | 0.7075E-01 | 0.0000E+00 | 0.4750E+01 | 0.5062E+00 | -0.2500E+01 |
| 2 | 0.1368E+02 | 0.5846E+03 | 0.3635E+00 | 0.1499E+02 | 0.9975E+00 | 0.7075E-01 | 0.3004E-09 | 0.4750E+01 | 0.5062E+00 | -0.2250E+01 |
| 3 | 0.1368E+02 | 0.5846E+03 | 0.3635E+00 | 0.1499E+02 | 0.9975E+00 | 0.7075E-01 | 0.2523E-09 | 0.4750E+01 | 0.5062E+00 | -0.2000E+01 |
| 4 | 0.1368E+02 | 0.5846E+03 | 0.3635E+00 | 0.1499E+02 | 0.9975E+00 | 0.7075E-01 | 0.5778E-09 | 0.4750E+01 | 0.5062E+00 | -0.1750E+01 |
| 5 | 0.1368E+02 | 0.5846E+03 | 0.3635E+00 | 0.1499E+02 | 0.9975E+00 | 0.7075E-01 | 0.5095E-09 | 0.4750E+01 | 0.5062E+00 | -0.1500E+01 |
| 6 | 0.1368E+02 | 0.5846E+03 | 0.3635E+00 | 0.1499E+02 | 0.9975E+00 | 0.7075E-01 | 0.3840E-09 | 0.4750E+01 | 0.5062E+00 | -0.1250E+01 |
| 7 | 0.1368E+02 | 0.5846E+03 | 0.3635E+00 | 0.1499E+02 | 0.9975E+00 | 0.7075E-01 | 0.1758E-09 | 0.4750E+01 | 0.5062E+00 | -0.1000E+01 |
| 8 | 0.1368E+02 | 0.5846E+03 | 0.3635E+00 | 0.1499E+02 | 0.9975E+00 | 0.7075E-01 | 0.9865E-10 | 0.4750E+01 | 0.5062E+00 | -0.7500E+00 |
| 9 | 0.1368E+02 | 0.5846E+03 | 0.3635E+00 | 0.1499E+02 | 0.9975E+00 | 0.7075E-01 | 0.6522E-10 | 0.4750E+01 | 0.5062E+00 | -0.5000E+00 |
| 10 | 0.1368E+02 | 0.5846E+03 | 0.3635E+00 | 0.1499E+02 | 0.9975E+00 | 0.7075E-01 | 0.4462E-10 | 0.4750E+01 | 0.5062E+00 | -0.2500E+00 |
| 11 | 0.1368E+02 | 0.5846E+03 | 0.3635E+00 | 0.1499E+02 | 0.9975E+00 | 0.7075E-01 | -0.3366E-12 | 0.4750E+01 | 0.5062E+00 | 0.0000E+00 |
| 12 | 0.1368E+02 | 0.5846E+03 | 0.3635E+00 | 0.1499E+02 | 0.9975E+00 | 0.7075E-01 | -0.4529E-10 | 0.4750E+01 | 0.5062E+00 | 0.2500E+00 |
| 13 | 0.1368E+02 | 0.5846E+03 | 0.3635E+00 | 0.1499E+02 | 0.9975E+00 | 0.7075E-01 | -0.6589E-10 | 0.4750E+01 | 0.5062E+00 | 0.5000E+00 |
| 14 | 0.1368E+02 | 0.5846E+03 | 0.3635E+00 | 0.1499E+02 | 0.9975E+00 | 0.7075E-01 | -0.9935E-10 | 0.4750E+01 | 0.5062E+00 | 0.7500E+00 |
| 15 | 0.1368E+02 | 0.5846E+03 | 0.3635E+00 | 0.1499E+02 | 0.9975E+00 | 0.7075E-01 | -0.1765E-09 | 0.4750E+01 | 0.5062E+00 | 0.1000E+01 |
| 16 | 0.1368E+02 | 0.5846E+03 | 0.3635E+00 | 0.1499E+02 | 0.9975E+00 | 0.7075E-01 | -0.3848E-09 | 0.4750E+01 | 0.5062E+00 | 0.1250E+01 |
| 17 | 0.1368E+02 | 0.5846E+03 | 0.3635E+00 | 0.1499E+02 | 0.9975E+00 | 0.7075E-01 | -0.5102E-09 | 0.4750E+01 | 0.5062E+00 | 0.1500E+01 |
| 18 | 0.1368E+02 | 0.5846E+03 | 0.3635E+00 | 0.1499E+02 | 0.9975E+00 | 0.7075E-01 | -0.5784E-09 | 0.4750E+01 | 0.5062E+00 | 0.1750E+01 |
| 19 | 0.1368E+02 | 0.5846E+03 | 0.3635E+00 | 0.1499E+02 | 0.9975E+00 | 0.7075E-01 | -0.2527E-09 | 0.4750E+01 | 0.5062E+00 | 0.2000E+01 |
| 20 | 0.1368E+02 | 0.5846E+03 | 0.3635E+00 | 0.1499E+02 | 0.9975E+00 | 0.7075E-01 | -0.3005E-09 | 0.4750E+01 | 0.5062E+00 | 0.2250E+01 |
| 21 | 0.1368E+02 | 0.5846E+03 | 0.3635E+00 | 0.1499E+02 | 0.9975E+00 | 0.7075E-01 | 0.0000E+00 | 0.4750E+01 | 0.5062E+00 | 0.2500E+01 |

| BLOCK 1 VARIABLES AT K, J = 4, 30 | | | | ITERATION NUMBER: 2500 | | | | | | |
|-----------------------------------|------------|-------------|-------------|------------------------|------------|------------|-------------|------------|------------|-------------|
| L | PRESSURE | TEMPERATURE | MACH NUMBER | TOTAL PRESS | U-COSINE | V-COSINE | W-COSINE | X | Y | Z |
| 1 | 0.1412E+02 | 0.5898E+03 | 0.2945E+00 | 0.1499E+02 | 0.1000E+01 | 0.9359E-02 | 0.0000E+00 | 0.7250E+01 | 0.6000E+00 | -0.2500E+01 |
| 2 | 0.1412E+02 | 0.5898E+03 | 0.2945E+00 | 0.1499E+02 | 0.1000E+01 | 0.9359E-02 | 0.2247E-09 | 0.7250E+01 | 0.6000E+00 | -0.2250E+01 |
| 3 | 0.1412E+02 | 0.5898E+03 | 0.2945E+00 | 0.1499E+02 | 0.1000E+01 | 0.9359E-02 | 0.2751E-09 | 0.7250E+01 | 0.6000E+00 | -0.2000E+01 |
| 4 | 0.1412E+02 | 0.5898E+03 | 0.2945E+00 | 0.1499E+02 | 0.1000E+01 | 0.9359E-02 | 0.3920E-09 | 0.7250E+01 | 0.6000E+00 | -0.1750E+01 |
| 5 | 0.1412E+02 | 0.5898E+03 | 0.2945E+00 | 0.1499E+02 | 0.1000E+01 | 0.9359E-02 | 0.3909E-09 | 0.7250E+01 | 0.6000E+00 | -0.1500E+01 |
| 6 | 0.1412E+02 | 0.5898E+03 | 0.2945E+00 | 0.1499E+02 | 0.1000E+01 | 0.9359E-02 | 0.2930E-09 | 0.7250E+01 | 0.6000E+00 | -0.1250E+01 |
| 7 | 0.1412E+02 | 0.5898E+03 | 0.2945E+00 | 0.1499E+02 | 0.1000E+01 | 0.9359E-02 | 0.1174E-09 | 0.7250E+01 | 0.6000E+00 | -0.1000E+01 |
| 8 | 0.1412E+02 | 0.5898E+03 | 0.2945E+00 | 0.1499E+02 | 0.1000E+01 | 0.9359E-02 | -0.3262E-10 | 0.7250E+01 | 0.6000E+00 | -0.7500E+00 |
| 9 | 0.1412E+02 | 0.5898E+03 | 0.2945E+00 | 0.1499E+02 | 0.1000E+01 | 0.9359E-02 | -0.1011E-09 | 0.7250E+01 | 0.6000E+00 | -0.5000E+00 |
| 10 | 0.1412E+02 | 0.5898E+03 | 0.2945E+00 | 0.1499E+02 | 0.1000E+01 | 0.9359E-02 | -0.7664E-10 | 0.7250E+01 | 0.6000E+00 | -0.2500E+00 |
| 11 | 0.1412E+02 | 0.5898E+03 | 0.2945E+00 | 0.1499E+02 | 0.1000E+01 | 0.9359E-02 | 0.1706E-12 | 0.7250E+01 | 0.6000E+00 | 0.0000E+00 |
| 12 | 0.1412E+02 | 0.5898E+03 | 0.2945E+00 | 0.1499E+02 | 0.1000E+01 | 0.9359E-02 | 0.7697E-10 | 0.7250E+01 | 0.6000E+00 | 0.2500E+00 |
| 13 | 0.1412E+02 | 0.5898E+03 | 0.2945E+00 | 0.1499E+02 | 0.1000E+01 | 0.9359E-02 | 0.1014E-09 | 0.7250E+01 | 0.6000E+00 | 0.5000E+00 |
| 14 | 0.1412E+02 | 0.5898E+03 | 0.2945E+00 | 0.1499E+02 | 0.1000E+01 | 0.9359E-02 | 0.3283E-10 | 0.7250E+01 | 0.6000E+00 | 0.7500E+00 |
| 15 | 0.1412E+02 | 0.5898E+03 | 0.2945E+00 | 0.1499E+02 | 0.1000E+01 | 0.9359E-02 | -0.1173E-09 | 0.7250E+01 | 0.6000E+00 | 0.1000E+01 |
| 16 | 0.1412E+02 | 0.5898E+03 | 0.2945E+00 | 0.1499E+02 | 0.1000E+01 | 0.9359E-02 | -0.2930E-09 | 0.7250E+01 | 0.6000E+00 | 0.1250E+01 |
| 17 | 0.1412E+02 | 0.5898E+03 | 0.2945E+00 | 0.1499E+02 | 0.1000E+01 | 0.9359E-02 | -0.3910E-09 | 0.7250E+01 | 0.6000E+00 | 0.1500E+01 |
| 18 | 0.1412E+02 | 0.5898E+03 | 0.2945E+00 | 0.1499E+02 | 0.1000E+01 | 0.9359E-02 | -0.3921E-09 | 0.7250E+01 | 0.6000E+00 | 0.1750E+01 |
| 19 | 0.1412E+02 | 0.5898E+03 | 0.2945E+00 | 0.1499E+02 | 0.1000E+01 | 0.9359E-02 | -0.2752E-09 | 0.7250E+01 | 0.6000E+00 | 0.2000E+01 |
| 20 | 0.1412E+02 | 0.5898E+03 | 0.2945E+00 | 0.1499E+02 | 0.1000E+01 | 0.9359E-02 | -0.2247E-09 | 0.7250E+01 | 0.6000E+00 | 0.2250E+01 |
| 21 | 0.1412E+02 | 0.5898E+03 | 0.2945E+00 | 0.1499E+02 | 0.1000E+01 | 0.9359E-02 | 0.0000E+00 | 0.7250E+01 | 0.6000E+00 | 0.2500E+01 |

Listing E-6. Continued

| BLOCK 1 VARIABLES AT K, J = 8, 10 | | | | ITERATION NUMBER: 2500 | | | | | | |
|-----------------------------------|------------|-------------|-------------|------------------------|------------|------------|-------------|------------|------------|-------------|
| L | PRESSURE | TEMPERATURE | MACH NUMBER | TOTAL PRESS | U-COSINE | V-COSINE | W-COSINE | X | Y | Z |
| 1 | 0.1052E+02 | 0.5424E+03 | 0.7186E+00 | 0.1484E+02 | 0.9921E+00 | 0.1251E+00 | 0.0000E+00 | 0.2250E+01 | 0.7437E+00 | -0.2500E+01 |
| 2 | 0.1052E+02 | 0.5424E+03 | 0.7186E+00 | 0.1484E+02 | 0.9921E+00 | 0.1251E+00 | 0.2919E-08 | 0.2250E+01 | 0.7437E+00 | -0.2250E+01 |
| 3 | 0.1052E+02 | 0.5424E+03 | 0.7186E+00 | 0.1484E+02 | 0.9921E+00 | 0.1251E+00 | 0.1465E-08 | 0.2250E+01 | 0.7437E+00 | -0.2000E+01 |
| 4 | 0.1052E+02 | 0.5424E+03 | 0.7186E+00 | 0.1484E+02 | 0.9921E+00 | 0.1251E+00 | 0.1635E-08 | 0.2250E+01 | 0.7437E+00 | -0.1750E+01 |
| 5 | 0.1052E+02 | 0.5424E+03 | 0.7186E+00 | 0.1484E+02 | 0.9921E+00 | 0.1251E+00 | 0.9203E-09 | 0.2250E+01 | 0.7437E+00 | -0.1500E+01 |
| 6 | 0.1052E+02 | 0.5424E+03 | 0.7186E+00 | 0.1484E+02 | 0.9921E+00 | 0.1251E+00 | 0.7677E-09 | 0.2250E+01 | 0.7437E+00 | -0.1250E+01 |
| 7 | 0.1052E+02 | 0.5424E+03 | 0.7186E+00 | 0.1484E+02 | 0.9921E+00 | 0.1251E+00 | 0.5852E-09 | 0.2250E+01 | 0.7437E+00 | -0.1000E+01 |
| 8 | 0.1052E+02 | 0.5424E+03 | 0.7186E+00 | 0.1484E+02 | 0.9921E+00 | 0.1251E+00 | 0.4473E-09 | 0.2250E+01 | 0.7437E+00 | -0.7500E+00 |
| 9 | 0.1052E+02 | 0.5424E+03 | 0.7186E+00 | 0.1484E+02 | 0.9921E+00 | 0.1251E+00 | 0.2950E-09 | 0.2250E+01 | 0.7437E+00 | -0.5000E+00 |
| 10 | 0.1052E+02 | 0.5424E+03 | 0.7186E+00 | 0.1484E+02 | 0.9921E+00 | 0.1251E+00 | 0.1457E-09 | 0.2250E+01 | 0.7437E+00 | -0.2500E+00 |
| 11 | 0.1052E+02 | 0.5424E+03 | 0.7186E+00 | 0.1484E+02 | 0.9921E+00 | 0.1251E+00 | -0.2399E-12 | 0.2250E+01 | 0.7437E+00 | 0.0000E+00 |
| 12 | 0.1052E+02 | 0.5424E+03 | 0.7186E+00 | 0.1484E+02 | 0.9921E+00 | 0.1251E+00 | -0.1462E-09 | 0.2250E+01 | 0.7437E+00 | 0.2500E+00 |
| 13 | 0.1052E+02 | 0.5424E+03 | 0.7186E+00 | 0.1484E+02 | 0.9921E+00 | 0.1251E+00 | -0.2955E-09 | 0.2250E+01 | 0.7437E+00 | 0.5000E+00 |
| 14 | 0.1052E+02 | 0.5424E+03 | 0.7186E+00 | 0.1484E+02 | 0.9921E+00 | 0.1251E+00 | -0.4478E-09 | 0.2250E+01 | 0.7437E+00 | 0.7500E+00 |
| 15 | 0.1052E+02 | 0.5424E+03 | 0.7186E+00 | 0.1484E+02 | 0.9921E+00 | 0.1251E+00 | -0.5857E-09 | 0.2250E+01 | 0.7437E+00 | 0.1000E+01 |
| 16 | 0.1052E+02 | 0.5424E+03 | 0.7186E+00 | 0.1484E+02 | 0.9921E+00 | 0.1251E+00 | -0.7682E-09 | 0.2250E+01 | 0.7437E+00 | 0.1250E+01 |
| 17 | 0.1052E+02 | 0.5424E+03 | 0.7186E+00 | 0.1484E+02 | 0.9921E+00 | 0.1251E+00 | -0.9209E-09 | 0.2250E+01 | 0.7437E+00 | 0.1500E+01 |
| 18 | 0.1052E+02 | 0.5424E+03 | 0.7186E+00 | 0.1484E+02 | 0.9921E+00 | 0.1251E+00 | -0.1636E-08 | 0.2250E+01 | 0.7437E+00 | 0.1750E+01 |
| 19 | 0.1052E+02 | 0.5424E+03 | 0.7186E+00 | 0.1484E+02 | 0.9921E+00 | 0.1251E+00 | -0.1466E-08 | 0.2250E+01 | 0.7437E+00 | 0.2000E+01 |
| 20 | 0.1052E+02 | 0.5424E+03 | 0.7186E+00 | 0.1484E+02 | 0.9921E+00 | 0.1251E+00 | -0.2919E-08 | 0.2250E+01 | 0.7437E+00 | 0.2250E+01 |
| 21 | 0.1052E+02 | 0.5424E+03 | 0.7186E+00 | 0.1484E+02 | 0.9921E+00 | 0.1251E+00 | 0.0000E+00 | 0.2250E+01 | 0.7437E+00 | 0.2500E+01 |

| BLOCK 1 VARIABLES AT K, J = 8, 20 | | | | ITERATION NUMBER: 2500 | | | | | | |
|-----------------------------------|------------|-------------|-------------|------------------------|------------|------------|-------------|------------|------------|-------------|
| L | PRESSURE | TEMPERATURE | MACH NUMBER | TOTAL PRESS | U-COSINE | V-COSINE | W-COSINE | X | Y | Z |
| 1 | 0.1374E+02 | 0.5855E+03 | 0.3513E+00 | 0.1496E+02 | 0.9859E+00 | 0.1675E+00 | 0.0000E+00 | 0.4750E+01 | 0.1181E+01 | -0.2500E+01 |
| 2 | 0.1374E+02 | 0.5855E+03 | 0.3513E+00 | 0.1496E+02 | 0.9859E+00 | 0.1675E+00 | 0.3928E-09 | 0.4750E+01 | 0.1181E+01 | -0.2250E+01 |
| 3 | 0.1374E+02 | 0.5855E+03 | 0.3513E+00 | 0.1496E+02 | 0.9859E+00 | 0.1675E+00 | 0.4332E-09 | 0.4750E+01 | 0.1181E+01 | -0.2000E+01 |
| 4 | 0.1374E+02 | 0.5855E+03 | 0.3513E+00 | 0.1496E+02 | 0.9859E+00 | 0.1675E+00 | 0.7417E-09 | 0.4750E+01 | 0.1181E+01 | -0.1750E+01 |
| 5 | 0.1374E+02 | 0.5855E+03 | 0.3513E+00 | 0.1496E+02 | 0.9859E+00 | 0.1675E+00 | 0.5986E-09 | 0.4750E+01 | 0.1181E+01 | -0.1500E+01 |
| 6 | 0.1374E+02 | 0.5855E+03 | 0.3513E+00 | 0.1496E+02 | 0.9859E+00 | 0.1675E+00 | 0.3885E-09 | 0.4750E+01 | 0.1181E+01 | -0.1250E+01 |
| 7 | 0.1374E+02 | 0.5855E+03 | 0.3513E+00 | 0.1496E+02 | 0.9859E+00 | 0.1675E+00 | 0.1377E-09 | 0.4750E+01 | 0.1181E+01 | -0.1000E+01 |
| 8 | 0.1374E+02 | 0.5855E+03 | 0.3513E+00 | 0.1496E+02 | 0.9859E+00 | 0.1675E+00 | 0.5768E-10 | 0.4750E+01 | 0.1181E+01 | -0.7500E+00 |
| 9 | 0.1374E+02 | 0.5855E+03 | 0.3513E+00 | 0.1496E+02 | 0.9859E+00 | 0.1675E+00 | 0.4019E-10 | 0.4750E+01 | 0.1181E+01 | -0.5000E+00 |
| 10 | 0.1374E+02 | 0.5855E+03 | 0.3513E+00 | 0.1496E+02 | 0.9859E+00 | 0.1675E+00 | 0.3424E-10 | 0.4750E+01 | 0.1181E+01 | -0.2500E+00 |
| 11 | 0.1374E+02 | 0.5855E+03 | 0.3513E+00 | 0.1496E+02 | 0.9859E+00 | 0.1675E+00 | -0.1337E-11 | 0.4750E+01 | 0.1181E+01 | 0.0000E+00 |
| 12 | 0.1374E+02 | 0.5855E+03 | 0.3513E+00 | 0.1496E+02 | 0.9859E+00 | 0.1675E+00 | -0.3690E-10 | 0.4750E+01 | 0.1181E+01 | 0.2500E+00 |
| 13 | 0.1374E+02 | 0.5855E+03 | 0.3513E+00 | 0.1496E+02 | 0.9859E+00 | 0.1675E+00 | -0.4285E-10 | 0.4750E+01 | 0.1181E+01 | 0.5000E+00 |
| 14 | 0.1374E+02 | 0.5855E+03 | 0.3513E+00 | 0.1496E+02 | 0.9859E+00 | 0.1675E+00 | -0.6040E-10 | 0.4750E+01 | 0.1181E+01 | 0.7500E+00 |
| 15 | 0.1374E+02 | 0.5855E+03 | 0.3513E+00 | 0.1496E+02 | 0.9859E+00 | 0.1675E+00 | -0.1406E-09 | 0.4750E+01 | 0.1181E+01 | 0.1000E+01 |
| 16 | 0.1374E+02 | 0.5855E+03 | 0.3513E+00 | 0.1496E+02 | 0.9859E+00 | 0.1675E+00 | -0.3916E-09 | 0.4750E+01 | 0.1181E+01 | 0.1250E+01 |
| 17 | 0.1374E+02 | 0.5855E+03 | 0.3513E+00 | 0.1496E+02 | 0.9859E+00 | 0.1675E+00 | -0.6019E-09 | 0.4750E+01 | 0.1181E+01 | 0.1500E+01 |
| 18 | 0.1374E+02 | 0.5855E+03 | 0.3513E+00 | 0.1496E+02 | 0.9859E+00 | 0.1675E+00 | -0.7447E-09 | 0.4750E+01 | 0.1181E+01 | 0.1750E+01 |
| 19 | 0.1374E+02 | 0.5855E+03 | 0.3513E+00 | 0.1496E+02 | 0.9859E+00 | 0.1675E+00 | -0.4356E-09 | 0.4750E+01 | 0.1181E+01 | 0.2000E+01 |
| 20 | 0.1374E+02 | 0.5855E+03 | 0.3513E+00 | 0.1496E+02 | 0.9859E+00 | 0.1675E+00 | -0.3942E-09 | 0.4750E+01 | 0.1181E+01 | 0.2250E+01 |
| 21 | 0.1374E+02 | 0.5855E+03 | 0.3513E+00 | 0.1496E+02 | 0.9859E+00 | 0.1675E+00 | 0.0000E+00 | 0.4750E+01 | 0.1181E+01 | 0.2500E+01 |

Listing E-6. Concluded

| BLOCK 1 VARIABLES AT K, J = 8, 30 | | | | | ITERATION NUMBER: 2500 | | | X | Y | Z |
|-----------------------------------|------------|-------------|-------------|-------------|------------------------|------------|-------------|------------|------------|-------------|
| L | PRESSURE | TEMPERATURE | MACH NUMBER | TOTAL PRESS | U-COSINE | V-COSINE | W-COSINE | | | |
| 1 | 0.1414E+02 | 0.5904E+03 | 0.2835E+00 | 0.1496E+02 | 0.9999E+00 | 0.1206E-01 | 0.0000E+00 | 0.7250E+01 | 0.1400E+01 | -0.2500E+01 |
| 2 | 0.1414E+02 | 0.5904E+03 | 0.2835E+00 | 0.1496E+02 | 0.9999E+00 | 0.1206E-01 | -0.9522E-10 | 0.7250E+01 | 0.1400E+01 | -0.2250E+01 |
| 3 | 0.1414E+02 | 0.5904E+03 | 0.2835E+00 | 0.1496E+02 | 0.9999E+00 | 0.1206E-01 | -0.2826E-09 | 0.7250E+01 | 0.1400E+01 | -0.2000E+01 |
| 4 | 0.1414E+02 | 0.5904E+03 | 0.2835E+00 | 0.1496E+02 | 0.9999E+00 | 0.1206E-01 | -0.2175E-09 | 0.7250E+01 | 0.1400E+01 | -0.1750E+01 |
| 5 | 0.1414E+02 | 0.5904E+03 | 0.2835E+00 | 0.1496E+02 | 0.9999E+00 | 0.1206E-01 | -0.4603E-10 | 0.7250E+01 | 0.1400E+01 | -0.1500E+01 |
| 6 | 0.1414E+02 | 0.5904E+03 | 0.2835E+00 | 0.1496E+02 | 0.9999E+00 | 0.1206E-01 | 0.1235E-09 | 0.7250E+01 | 0.1400E+01 | -0.1250E+01 |
| 7 | 0.1414E+02 | 0.5904E+03 | 0.2835E+00 | 0.1496E+02 | 0.9999E+00 | 0.1206E-01 | 0.1865E-09 | 0.7250E+01 | 0.1400E+01 | -0.1000E+01 |
| 8 | 0.1414E+02 | 0.5904E+03 | 0.2835E+00 | 0.1496E+02 | 0.9999E+00 | 0.1206E-01 | 0.1645E-09 | 0.7250E+01 | 0.1400E+01 | -0.7500E+00 |
| 9 | 0.1414E+02 | 0.5904E+03 | 0.2835E+00 | 0.1496E+02 | 0.9999E+00 | 0.1206E-01 | 0.1054E-09 | 0.7250E+01 | 0.1400E+01 | -0.5000E+00 |
| 10 | 0.1414E+02 | 0.5904E+03 | 0.2835E+00 | 0.1496E+02 | 0.9999E+00 | 0.1206E-01 | 0.4874E-10 | 0.7250E+01 | 0.1400E+01 | -0.2500E+00 |
| 11 | 0.1414E+02 | 0.5904E+03 | 0.2835E+00 | 0.1496E+02 | 0.9999E+00 | 0.1206E-01 | -0.1057E-11 | 0.7250E+01 | 0.1400E+01 | 0.0000E+00 |
| 12 | 0.1414E+02 | 0.5904E+03 | 0.2835E+00 | 0.1496E+02 | 0.9999E+00 | 0.1206E-01 | -0.5086E-10 | 0.7250E+01 | 0.1400E+01 | 0.2500E+00 |
| 13 | 0.1414E+02 | 0.5904E+03 | 0.2835E+00 | 0.1496E+02 | 0.9999E+00 | 0.1206E-01 | -0.1075E-09 | 0.7250E+01 | 0.1400E+01 | 0.5000E+00 |
| 14 | 0.1414E+02 | 0.5904E+03 | 0.2835E+00 | 0.1496E+02 | 0.9999E+00 | 0.1206E-01 | -0.1666E-09 | 0.7250E+01 | 0.1400E+01 | 0.7500E+00 |
| 15 | 0.1414E+02 | 0.5904E+03 | 0.2835E+00 | 0.1496E+02 | 0.9999E+00 | 0.1206E-01 | -0.1885E-09 | 0.7250E+01 | 0.1400E+01 | 0.1000E+01 |
| 16 | 0.1414E+02 | 0.5904E+03 | 0.2835E+00 | 0.1496E+02 | 0.9999E+00 | 0.1206E-01 | -0.1252E-09 | 0.7250E+01 | 0.1400E+01 | 0.1250E+01 |
| 17 | 0.1414E+02 | 0.5904E+03 | 0.2835E+00 | 0.1496E+02 | 0.9999E+00 | 0.1206E-01 | 0.4463E-10 | 0.7250E+01 | 0.1400E+01 | 0.1500E+01 |
| 18 | 0.1414E+02 | 0.5904E+03 | 0.2835E+00 | 0.1496E+02 | 0.9999E+00 | 0.1206E-01 | 0.2166E-09 | 0.7250E+01 | 0.1400E+01 | 0.1750E+01 |
| 19 | 0.1414E+02 | 0.5904E+03 | 0.2835E+00 | 0.1496E+02 | 0.9999E+00 | 0.1206E-01 | 0.2820E-09 | 0.7250E+01 | 0.1400E+01 | 0.2000E+01 |
| 20 | 0.1414E+02 | 0.5904E+03 | 0.2835E+00 | 0.1496E+02 | 0.9999E+00 | 0.1206E-01 | 0.9495E-10 | 0.7250E+01 | 0.1400E+01 | 0.2250E+01 |
| 21 | 0.1414E+02 | 0.5904E+03 | 0.2835E+00 | 0.1496E+02 | 0.9999E+00 | 0.1206E-01 | 0.0000E+00 | 0.7250E+01 | 0.1400E+01 | 0.2500E+01 |

Listing E-7. Grid and Initial Condition Generator (Multiblock)

```

1  1.  PROGRAM ICFILE
2  2.  PARAMETER(JD=33,KD=11)
3  3.  DIMENSION R(JD,KD),RU(JD,KD),RV(JD,KD),E(JD,KD)
4  4.  DIMENSION X(JD,KD),Y(JD,KD)
5  5.  DATA G/1.4/
6  6.  GM1=G-1.
7  7.  DELX=8./32
8  8.  C FORM THE 'X' GRID ARRAY
9  9.  DO 1 J=1,JD
10 10. DO 1 K=1,KD
11 11. IF(J.EQ.1) THEN
12 12. X(J,K)=0.
13 13. ELSE
14 14. X(J,K)=X(J-1,K)+DELX
15 15. ENDF
16 16. 1 CONTINUE
17 17. C FORM THE 'Y' GRID ARRAYS
18 18. DO 2 J=1,JD
19 19. IF(X(J,KD).LE.2.) YO=1.
20 20. IF(X(J,KD).GT.6.) YO=2.
21 21. IF((X(J,KD).GT.2.)AND.(X(J,KD).LE.6.)) THEN
22 22. YO=1.+(X(J,KD)-2.)*0.25
23 23. ENDF
24 24. DELY=YO/(KD-1)
25 25. Y(J,1)=0.0
26 26. DO 2 K=2,KD
27 27. Y(J,K)=Y(J,K-1)+DELY
28 28. 2 CONTINUE
29 29. C FORM THE ARRAYS OF NON-DIMENSIONAL CONSERVATION VARIABLES
30 30. C CONSISTENT WITH A FREE-STREAM MACH NUMBER OF 0.29
31 31. FMACH=0.29
32 32. FACT=(1.+.2*FMACH**2)
33 33. PBAR=FACT**(-3.5)/G
34 34. DO 1000 J=1,JD
35 35. DO 2000 K=1,KD
36 36. R(J,K)=FACT**(-2.5)
37 37. RU(J,K)=R(J,K)*FMACH*SQRT(1./FACT)
38 38. RV(J,K)=0.
39 39. E(J,K)=PBAR/GM1+.5*(RU(J,K)**2)/R(J,K)
40 40. 2000 CONTINUE
41 41. 1000 CONTINUE

```

Listing E-7. Concluded

```

42 38.      NC1=0
43 39.      WRITE(20)NC1,G
44 40.      WRITE(20)15,6
45 41.      WRITE(20)(( X(J,K),J= 1,15),K=1, 6),
46          *      (( Y(J,K),J= 1,15),K=1, 6)
47 42.      WRITE(20)(( R(J,K),J= 1,15),K=1, 6),
48          *      ((RU(J,K),J= 1,15),K=1, 6),
49          *      ((RV(J,K),J= 1,15),K=1, 6),
50          *      (( E(J,K),J= 1,15),K=1, 6)
51 43.      WRITE(20)15,7
52 44.      WRITE(20)(( X(J,K),J= 1,15),K=5,11),
53          *      (( Y(J,K),J= 1,15),K=5,11)
54 45.      WRITE(20)(( R(J,K),J= 1,15),K=5,11),
55          *      ((RU(J,K),J= 1,15),K=5,11),
56          *      ((RV(J,K),J= 1,15),K=5,11),
57          *      (( E(J,K),J= 1,15),K=5,11)
58 46.      WRITE(20)20,11
59 47.      WRITE(20)(( X(J,K),J=14,33),K=1,11),
60          *      (( Y(J,K),J=14,33),K=1,11)
61 48.      WRITE(20)(( R(J,K),J=14,33),K=1,11),
62          *      ((RU(J,K),J=14,33),K=1,11),
63          *      ((RV(J,K),J=14,33),K=1,11),
64          *      (( E(J,K),J=14,33),K=1,11)
65 49.      STOP
66 50.      END

```

Listing E-8. Execution and Input File (Multiblock)

```

//A05569X JOB (SVT,ATT00000,00,78904912),'DCM TODD EL2 CFD',
// CLASS=X,TIME=(,5),USER=A05569,PASSWORD=XXXXXXXX,MSGCLASS=Z,
// MSGLEVEL=1,PRTY=8,NOTIFY=A05569
/**
/*ROUTE PRINT RMT0
/*JOBPARM ROOM=5 2ND FLOOR DO BLDG 1099
/**
// EXEC CRAY
CRSUBMIT F(OSJOB) NOTIFY(A05569) DEST(RMT0) PRINT(3) HOLD
//OSJOB DD *
JOB, JN=A05569Y, T=150, MFL.
ACCOUNT, AC=78904910, US=A05569.
FETCH, DN=CODE, TEXT='DSN=A05569.BARC(BARC2D), DISP=SHR'.
CFT, I=CODE, L=0.
ACCESS, DN=BNCHLIB, PDN=BNCHLIB, ID=BNCHMRK, OWN=SYSTEM.
ACCESS, DN=FT02, PDN=ICCASE3.
LDR, LIB=BNCHLIB.
*SAVE, DN=FT04, PDN=RSCASE3.
DISPOSE, DN=FT04, DC=ST, DF=TR, TEXT='
'DSN=A05569.TRCASE3.REST, DISP=(,CATLG), '
'UNIT=DISK, SPACE=(CYL,(38),RLSE), '
'DCB=(RECFM=F, LRECL=4096, BLKSIZE=4096)'.
/EOF
$INPUTS
  NMAX=2500,      NP=2500,
  PREF=15.0,     TREFR=600.,
  IFXPRT=1,      NBLOCK=3,
  DIS2=0.00,     DIS4=0.30,
  DTCAP= 7.0,    PCQMAX=10.0,
  NSPRT=50,      IAXISY=0,      STOPL2=1.E-20,
$
$BLOCK :#1
  NPSEG=1,
  INVISC(1)=0,  INVISC(2)=0,
$
$PRTSEG
  JKLPI(1,1,1)=2,14,2,  JKLPI(1,2,1)=2,4,2,  IPORD(1)=1,
$
$BOUNDS
  NJSEG=2,
  JLINE(1)=1,
  JKLOW(1)=2,  JKHIGH(1)=5,      JTYPE(1)=0,
  JSIGN(1)=1,  PRESSJ(1)=0.7142857,  TEMPJ(1)=1.0,
  JLINE(2)=15,
  JKLOW(2)=2,  JKHIGH(2)=6,      JTYPE(2)=70,
  JSIGN(2)=-1,  INTERJ(2)=1,
  NKSEG=2,
  KLINE(1)=1,
  KJLOW(1)=1,  KJHIGH(1)=15,      KTYPE(1)=50,
  KSIGN(1)=1,
  KLINE(2)=6,
  KJLOW(2)=1,  KJHIGH(2)=14,     KTYPE(2)=70,
  KSIGN(2)=-1,  INTERK(2)=2,
$
$BLOCK :#2
  NPSEG=1,
  INVISC(1)=0,  INVISC(2)=0,
$
$PRTSEG
  JKLPI(1,1,1)=2,14,2,  JKLPI(1,2,1)=2,4,2,  IPORD(1)=1,
$

```

Listing E-8. Concluded

```

$BOUNDS
  NJSEG=2,
    JLINE(1)=1,
      JKLOW(1)=2,   JKHIGH(1)=6,   JTYPE(1)=0,
      JSIGN(1)=1,   PRESSJ(1)=0.7142857, TEMPJ(1)=1.0,
    JLINE(2)=15,
      JKLOW(2)=1,   JKHIGH(2)=6,   JTYPE(2)=70,
      JSIGN(2)=-1, INTERJ(2)=3,
  NKSEG=2,
    KLINE(1)=1,
      KJLOW(1)=1,   KJHIGH(1)=14,   KTYPE(1)=70,
      KSIGN(1)=1,   INTERK(1)=2,
    KLINE(2)=7,
      KJLOW(2)=1,   KJHIGH(2)=15,   KTYPE(2)=50,
      KSIGN(2)=-1,
$
$BLOCK :#3
  NPSEG=1,
  INVISC(1)=0, INVISC(2)=0,
$
$PRTSEG
  JKLP1(1,1,1)=1,19,2,   JKLP1(1,2,1)=2,10,2,   IPORD(1)=1,
$
$BOUNDS
  NJSEG=3,
    JLINE(1)=1,
      JKLOW(1)=2,   JKHIGH(1)=6,   JTYPE(1)=70,
      JSIGN(1)=1,   INTERJ(1)=1,
    JLINE(2)=1,
      JKLOW(2)=5,   JKHIGH(2)=10,   JTYPE(2)=70,
      JSIGN(2)=1,   INTERJ(2)=3,
    JLINE(3)=20,
      JKLOW(3)=2,   JKHIGH(3)=10,   JTYPE(3)=0,
      JSIGN(3)=-1, PRESSJ(3)=0.67285, TEMPJ(3)=1.0,
  NKSEG=2,
    KLINE(1)=1,
      KJLOW(1)=1,   KJHIGH(1)=20,   KTYPE(1)=50,
      KSIGN(1)=1,
    KLINE(2)=11,
      KJLOW(2)=1,   KJHIGH(2)=20,   KTYPE(2)=50,
      KSIGN(2)=-1,
$
/EOJ

```

Listing E-9. Multiblock Output

NAMLIST INPUTS:

```

PREF = 0.150000E+02      IAXISY = 0
TREFR = 0.600000E+03     NBLOCK = 3
VRAT = -0.666667E+00     NMAX = 2500
TSUTH = 0.198600E+03     NC = 0
RE = 0.000000E+00       NSPRT = 50
PR = 0.720000E+00       NP = 2500
PRT = 0.900000E+00      IFXPRT = 1
DIS2 = 0.000000E+00     IFXPLT = 0
DIS4 = 0.300000E+00     L2PLOT = 0
DTCAP = 0.700000E+01    IPLOT = 0
PCQMAX = 0.100000E+02   LMODE = 1
SPLEND = 0.100000E+01  MBORD = 3
SHOO = 0.000000E+00    NUMDT = 0
STOPL2 = 0.100000E-19  IWARDT = 2
STOPTR = 0.500000E+01  ISOLVE = 1
ALPHA = 0.000000E+00   IRNS = 1
XNACH = 0.000000E+00   IFILTR = 1
                          IMUTUR = 1
    
```

THE ORDER OF BLOCK PROCESSING FOLLOWS
1, 2, 3

FOR BLOCK 1
JMAX = 15 KMAX = 6
NM = 15 IJK = 90

```

NAMLIST BLOCK FOR BLOCK 1
GAMMA = 0.140000E+01     INVISC = 0 0
COFMIX = 0.900000E-01    LAMIN = 0 0
DTBLK = 0.000000E+00     NPSEG = 1
                          NBCSEG = 0
    
```

```

NAMLIST PRASEG FOR BLOCK 1
JKLPI
      JA  JB  JS          KA  KB  KS          IPORD
      2  14  2          2   4   2          J  K
1     2  14  2          2   4   2          1  2
    
```

```

NAMLIST BOUNDS FOR BLOCK 1
JSEG  JLINE  JKLOW  JKHIGH  JTYPE  INTERJ  JSIGN  PRESSJ  TEMPJ  JTYPE
1     1     2     5     0         1     1     0.714286E+00  0.100000E+01  FREE
2     15    2     6     70        1    -1          -          -          CONTIGUOUS
KSEG  KLINE  KJLOW  KJHIGH  KTYPE  INTERK  KSIGN  PRESSK  TEMPK  KTYPE
1     1     1     15    50         1     1          -          -          SLIP
2     6     1     14    70         2    -1          -          -          CONTIGUOUS
    
```

GRID PATCHES FOR BLOCK 1

```

J-PATCHES  MINIMUM  MAXIMUM
            J  K      J  K
1          2  2      14  5
    
```

```

K-PATCHES  MINIMUM  MAXIMUM
            J  K      J  K
1          2  2      14  5
    
```

FOR BLOCK 2
JMAX = 15 KMAX = 7
NM = 15 IJK = 105

```

NAMLIST BLOCK FOR BLOCK 2
GAMMA = 0.140000E+01     INVISC = 0 0
COFMIX = 0.900000E-01    LAMIN = 0 0
DTBLK = 0.000000E+00     NPSEG = 1
                          NBCSEG = 0
    
```

Listing E-9. Continued

NAMELIST PRTSEG FOR BLOCK 2

| | | | | | | | | |
|---|----|----|----|-------|----|----|-------|---|
| | | | | JKLPI | | | IPORD | |
| | JA | JB | JS | KA | KB | KS | J | K |
| 1 | 2 | 14 | 2 | 2 | 4 | 2 | 1 | 2 |

NAMELIST BOUNDS FOR BLOCK 2

| | | | | | | | | | |
|------|-------|-------|--------|-------|--------|-------|--------------|--------------|------------|
| JSEG | JLINE | JKLOW | JKHIGH | JTYPE | INTERJ | JSIGN | PRESSJ | TEMPJ | JTYPE |
| 1 | 1 | 2 | 6 | 0 | | 1 | 0.714286E+00 | 0.100000E+01 | FREE |
| 2 | 15 | 1 | 6 | 70 | 3 | -1 | | | CONTIGUOUS |
| KSEG | KLINE | KJLOW | KJHIGH | KTYPE | INTERK | KSIGN | PRESSK | TEMPK | KTYPE |
| 1 | 1 | 1 | 14 | 70 | 2 | 1 | | | CONTIGUOUS |
| 2 | 7 | 1 | 15 | 50 | | -1 | | | SLIP |

GRID PATCHES FOR BLOCK 2

| | | | | |
|-----------|---------|---|---------|---|
| J-PATCHES | MINIMUM | | MAXIMUM | |
| | J | K | J | K |
| 1 | 2 | 2 | 14 | 6 |

| | | | | |
|-----------|---------|---|---------|---|
| K-PATCHES | MINIMUM | | MAXIMUM | |
| | J | K | J | K |
| 1 | 2 | 2 | 14 | 6 |

FOR BLOCK 3

JMAX = 20 KMAX = 11
 NM = 20 IJK = 220

NAMELIST BLOCK FOR BLOCK 3

| | | | | | | |
|--------|---|--------------|--------|---|---|---|
| GAMMA | = | 0.140000E+01 | INVISC | = | 0 | 0 |
| COFMIX | = | 0.900000E-01 | LAMIN | = | 0 | 0 |
| DTBLK | = | 0.000000E+00 | NPSEG | = | 1 | |
| | | | NBCSEG | = | 0 | |

NAMELIST PRTSEG FOR BLOCK 3

| | | | | | | | | |
|---|----|----|----|-------|----|----|-------|---|
| | | | | JKLPI | | | IPORD | |
| | JA | JB | JS | KA | KB | KS | J | K |
| 1 | 1 | 19 | 2 | 2 | 10 | 2 | 1 | 2 |

NAMELIST BOUNDS FOR BLOCK 3

| | | | | | | | | | |
|------|-------|-------|--------|-------|--------|-------|--------------|--------------|------------|
| JSEG | JLINE | JKLOW | JKHIGH | JTYPE | INTERJ | JSIGN | PRESSJ | TEMPJ | JTYPE |
| 1 | 1 | 2 | 6 | 70 | 1 | 1 | | | CONTIGUOUS |
| 2 | 1 | 5 | 10 | 70 | 3 | 1 | | | CONTIGUOUS |
| 3 | 20 | 2 | 10 | 0 | | -1 | 0.672850E+00 | 0.100000E+01 | FREE |
| KSEG | KLINE | KJLOW | KJHIGH | KTYPE | INTERK | KSIGN | PRESSK | TEMPK | KTYPE |
| 1 | 1 | 1 | 20 | 50 | | 1 | | | SLIP |
| 2 | 11 | 1 | 20 | 50 | | -1 | | | SLIP |

GRID PATCHES FOR BLOCK 3

| | | | | |
|-----------|---------|---|---------|----|
| J-PATCHES | MINIMUM | | MAXIMUM | |
| | J | K | J | K |
| 1 | 2 | 2 | 19 | 10 |

| | | | | |
|-----------|---------|---|---------|----|
| K-PATCHES | MINIMUM | | MAXIMUM | |
| | J | K | J | K |
| 1 | 2 | 2 | 19 | 10 |

Listing E-9. Continued

| COUNT | BLOCK | DT | L2 RESIDUAL | MASS FLUX | MOMENTUM X | FLUXES Y | ENERGY FLUX | MAX PERCENT VARIATION | MAX LOCATION J | K |
|-------|-------|------------|-------------|-------------|---------------|-------------|-------------|--------------------------|-------------------|---|
| 50 | 1 | 0.7000E+01 | 0.2285E-03 | -0.2396E-02 | 0.4552E-02 | -0.5938E-02 | -0.2479E-02 | 0.8977E+00 | 3 | 5 |
| 50 | 2 | 0.7000E+01 | 0.2260E-03 | -0.2424E-02 | 0.4345E-02 | -0.5790E-03 | -0.2495E-02 | 0.6152E+00 | 9 | 6 |
| 50 | 3 | 0.7000E+01 | 0.1375E-03 | -0.4774E-03 | -0.3620E-03 | -0.2193E-03 | -0.6867E-03 | 0.3204E+00 | 2 | 3 |
| 100 | 1 | 0.7000E+01 | 0.7362E-04 | -0.8228E-03 | 0.1986E-02 | -0.6602E-03 | -0.6920E-03 | 0.2380E+00 | 14 | 2 |
| 100 | 2 | 0.7000E+01 | 0.7123E-04 | -0.8323E-03 | 0.1955E-02 | 0.1047E-02 | -0.6965E-03 | 0.2570E+00 | 14 | 2 |
| 100 | 3 | 0.7000E+01 | 0.7019E-04 | -0.4323E-04 | 0.1062E-02 | 0.5491E-03 | -0.1126E-04 | 0.1910E+00 | 19 | 2 |
| 150 | 1 | 0.7000E+01 | 0.4860E-04 | -0.5889E-03 | 0.1139E-02 | 0.9675E-04 | -0.4913E-03 | 0.1534E+00 | 14 | 2 |
| 150 | 2 | 0.7000E+01 | 0.4749E-04 | -0.6048E-03 | 0.1084E-02 | 0.4176E-03 | -0.5113E-03 | 0.1658E+00 | 9 | 6 |
| 150 | 3 | 0.7000E+01 | 0.3268E-04 | -0.3383E-04 | 0.6313E-03 | 0.7385E-03 | -0.1179E-04 | 0.1030E+00 | 19 | 2 |
| 200 | 1 | 0.7000E+01 | 0.3302E-04 | -0.4157E-03 | 0.6789E-03 | 0.1587E-03 | -0.3466E-03 | 0.1007E+00 | 14 | 2 |
| 200 | 2 | 0.7000E+01 | 0.3215E-04 | -0.4256E-03 | 0.6489E-03 | 0.2108E-03 | -0.3582E-03 | 0.1208E+00 | 9 | 6 |
| 200 | 3 | 0.7000E+01 | 0.1618E-04 | -0.2168E-04 | 0.3963E-03 | 0.5747E-03 | -0.5956E-05 | 0.7269E-01 | 19 | 2 |
| 250 | 1 | 0.7000E+01 | 0.2294E-04 | -0.2989E-03 | 0.4209E-03 | 0.9561E-04 | -0.2515E-03 | 0.6359E-01 | 14 | 2 |
| 250 | 2 | 0.7000E+01 | 0.2240E-04 | -0.3049E-03 | 0.4005E-03 | 0.1032E-03 | -0.2585E-03 | 0.8937E-01 | 9 | 6 |
| 250 | 3 | 0.7000E+01 | 0.9082E-05 | -0.1492E-04 | 0.2457E-03 | 0.2689E-03 | -0.4941E-05 | 0.4484E-01 | 19 | 2 |
| 300 | 1 | 0.7000E+01 | 0.1579E-04 | -0.2089E-03 | 0.2672E-03 | 0.2067E-04 | -0.1763E-03 | 0.3988E-01 | 14 | 2 |
| 300 | 2 | 0.7000E+01 | 0.1543E-04 | -0.2129E-03 | 0.2528E-03 | 0.5517E-04 | -0.1812E-03 | 0.6309E-01 | 9 | 6 |
| 300 | 3 | 0.7000E+01 | 0.5458E-05 | -0.9724E-05 | 0.1557E-03 | 0.1845E-03 | -0.3135E-05 | 0.2967E-01 | 19 | 2 |
| 350 | 1 | 0.7000E+01 | 0.1080E-04 | -0.1444E-03 | 0.1725E-03 | 0.6485E-05 | -0.1222E-03 | 0.2657E-01 | 14 | 2 |
| 350 | 2 | 0.7000E+01 | 0.1057E-04 | -0.1472E-03 | 0.1623E-03 | 0.2940E-04 | -0.1256E-03 | 0.4409E-01 | 9 | 6 |
| 350 | 3 | 0.7000E+01 | 0.3433E-05 | -0.6334E-05 | 0.1004E-03 | 0.1169E-03 | -0.1958E-05 | 0.1906E-01 | 19 | 2 |
| 400 | 1 | 0.7000E+01 | 0.7357E-05 | -0.9890E-04 | 0.1127E-03 | 0.2215E-05 | -0.8378E-04 | 0.1767E-01 | 14 | 2 |
| 400 | 2 | 0.7000E+01 | 0.7197E-05 | -0.1007E-03 | 0.1058E-03 | 0.1661E-04 | -0.8608E-04 | 0.3027E-01 | 9 | 6 |
| 400 | 3 | 0.7000E+01 | 0.2239E-05 | -0.4164E-05 | 0.6556E-04 | 0.7715E-04 | -0.1244E-05 | 0.1257E-01 | 19 | 2 |
| 450 | 1 | 0.7000E+01 | 0.4986E-05 | -0.6728E-04 | 0.7424E-04 | -0.8083E-06 | -0.5704E-04 | 0.1206E-01 | 4 | 2 |
| 450 | 2 | 0.7000E+01 | 0.4877E-05 | -0.6848E-04 | 0.6960E-04 | 0.9043E-05 | -0.5855E-04 | 0.2066E-01 | 9 | 6 |
| 450 | 3 | 0.7000E+01 | 0.1480E-05 | -0.2745E-05 | 0.4529E-04 | 0.4999E-04 | -0.7854E-06 | 0.8316E-02 | 19 | 2 |
| 500 | 1 | 0.7000E+01 | 0.3372E-05 | -0.4561E-04 | 0.4926E-04 | -0.2800E-05 | -0.3869E-04 | 0.8225E-02 | 4 | 2 |
| 500 | 2 | 0.7000E+01 | 0.3300E-05 | -0.4642E-04 | 0.4609E-04 | 0.5704E-05 | -0.3972E-04 | 0.1404E-01 | 9 | 6 |
| 500 | 3 | 0.7000E+01 | 0.9826E-06 | -0.1819E-05 | 0.2871E-04 | 0.3309E-04 | -0.5081E-06 | 0.5538E-02 | 19 | 2 |
| 550 | 1 | 0.7000E+01 | 0.2277E-05 | -0.3084E-04 | 0.3280E-04 | 0.1561E-06 | -0.2618E-04 | 0.5588E-02 | 4 | 2 |
| 550 | 2 | 0.7000E+01 | 0.2228E-05 | -0.3138E-04 | 0.3067E-04 | 0.3338E-05 | -0.2686E-04 | 0.9516E-02 | 9 | 6 |
| 550 | 3 | 0.7000E+01 | 0.6558E-06 | -0.1209E-05 | 0.1914E-04 | 0.2224E-04 | -0.3286E-06 | 0.3701E-02 | 19 | 2 |
| 600 | 1 | 0.7000E+01 | 0.1535E-05 | -0.2081E-04 | 0.2193E-04 | -0.9945E-06 | -0.1767E-04 | 0.3778E-02 | 4 | 2 |
| 600 | 2 | 0.7000E+01 | 0.1501E-05 | -0.2115E-04 | 0.2052E-04 | 0.2047E-05 | -0.1809E-04 | 0.6434E-02 | 9 | 6 |
| 600 | 3 | 0.7000E+01 | 0.4385E-06 | -0.7969E-06 | 0.1280E-04 | 0.1484E-04 | -0.2069E-06 | 0.2667E-02 | 19 | 2 |
| 650 | 1 | 0.7000E+01 | 0.1033E-05 | -0.1401E-04 | 0.1469E-04 | -0.2006E-05 | -0.1191E-04 | 0.2543E-02 | 4 | 2 |
| 650 | 2 | 0.7000E+01 | 0.1012E-05 | -0.1425E-04 | 0.1373E-04 | 0.1241E-05 | -0.1220E-04 | 0.4332E-02 | 9 | 6 |
| 650 | 3 | 0.7000E+01 | 0.2941E-06 | -0.5273E-06 | 0.8596E-05 | 0.9923E-05 | -0.1271E-06 | 0.1644E-02 | 19 | 2 |
| 700 | 1 | 0.7000E+01 | 0.6955E-06 | -0.9419E-05 | 0.9878E-05 | 0.2605E-06 | -0.7991E-05 | 0.1720E-02 | 4 | 2 |
| 700 | 2 | 0.7000E+01 | 0.6801E-06 | -0.9574E-05 | 0.9236E-05 | 0.1087E-05 | -0.8185E-05 | 0.2923E-02 | 9 | 6 |
| 700 | 3 | 0.7000E+01 | 0.1982E-06 | -0.3448E-06 | 0.5774E-05 | 0.6606E-05 | -0.7555E-07 | 0.1117E-02 | 19 | 2 |
| 750 | 1 | 0.7000E+01 | 0.4672E-06 | -0.6325E-05 | 0.6654E-05 | 0.6193E-06 | -0.5363E-05 | 0.1168E-02 | 4 | 2 |
| 750 | 2 | 0.7000E+01 | 0.4567E-06 | -0.6432E-05 | 0.6213E-05 | 0.1130E-05 | -0.5499E-05 | 0.1937E-02 | 9 | 6 |
| 750 | 3 | 0.7000E+01 | 0.1336E-06 | -0.2209E-06 | 0.3895E-05 | 0.4652E-05 | -0.3800E-07 | 0.7456E-03 | 19 | 2 |
| 800 | 1 | 0.7000E+01 | 0.3137E-06 | -0.4231E-05 | 0.4478E-05 | -0.7246E-06 | -0.3585E-05 | 0.7756E-03 | 4 | 2 |
| 800 | 2 | 0.7000E+01 | 0.3065E-06 | -0.4315E-05 | 0.4184E-05 | 0.2644E-06 | -0.3692E-05 | 0.1292E-02 | 9 | 6 |
| 800 | 3 | 0.7000E+01 | 0.8951E-07 | -0.1414E-06 | 0.2627E-05 | 0.2921E-05 | -0.1999E-07 | 0.5111E-03 | 19 | 2 |
| 850 | 1 | 0.7000E+01 | 0.2100E-06 | -0.2825E-05 | 0.3066E-05 | -0.5323E-06 | -0.2380E-05 | 0.5277E-03 | 5 | 2 |
| 850 | 2 | 0.7000E+01 | 0.2060E-06 | -0.2887E-05 | 0.2848E-05 | 0.3068E-06 | -0.2460E-05 | 0.8824E-03 | 9 | 6 |
| 850 | 3 | 0.7000E+01 | 0.6117E-07 | -0.8168E-07 | 0.1777E-05 | 0.2065E-05 | 0.3232E-08 | 0.3280E-03 | 19 | 2 |

Listing E-9. Continued

| | | | | | | | | | | |
|------|---|------------|------------|-------------|------------|-------------|-------------|------------|----|----|
| 900 | 1 | 0.7000E+01 | 0.1404E-06 | -0.1871E-05 | 0.2080E-05 | 0.6761E-06 | -0.1574E-05 | 0.3593E-03 | 4 | 2 |
| 900 | 2 | 0.7000E+01 | 0.1373E-06 | -0.1921E-05 | 0.1942E-05 | 0.1984E-06 | -0.1629E-05 | 0.5722E-03 | 9 | 6 |
| 900 | 3 | 0.7000E+01 | 0.4205E-07 | -0.4948E-07 | 0.1215E-05 | 0.1317E-05 | 0.9071E-08 | 0.2184E-03 | 19 | 2 |
| 950 | 1 | 0.7000E+01 | 0.9511E-07 | -0.1274E-05 | 0.1383E-05 | 0.5525E-06 | -0.1082E-05 | 0.2565E-03 | 4 | 2 |
| 950 | 2 | 0.7000E+01 | 0.9188E-07 | -0.1277E-05 | 0.1323E-05 | 0.2956E-06 | -0.1078E-05 | 0.3819E-03 | 9 | 6 |
| 950 | 3 | 0.7000E+01 | 0.2889E-07 | -0.2593E-07 | 0.8356E-06 | 0.7951E-06 | 0.1708E-07 | 0.1543E-03 | 19 | 2 |
| 1000 | 1 | 0.7000E+01 | 0.6319E-07 | -0.8242E-06 | 0.9688E-06 | -0.2356E-07 | -0.6860E-06 | 0.1647E-03 | 4 | 2 |
| 1000 | 2 | 0.7000E+01 | 0.6096E-07 | -0.8321E-06 | 0.9159E-06 | -0.1191E-06 | -0.6950E-06 | 0.2371E-03 | 9 | 6 |
| 1000 | 3 | 0.7000E+01 | 0.2079E-07 | -0.8197E-08 | 0.5813E-06 | 0.6961E-06 | 0.2343E-07 | 0.9815E-04 | 19 | 2 |
| 1050 | 1 | 0.7000E+01 | 0.4159E-07 | -0.5405E-06 | 0.6757E-06 | 0.5503E-06 | -0.4513E-06 | 0.1160E-03 | 9 | 5 |
| 1050 | 2 | 0.7000E+01 | 0.4103E-07 | -0.5479E-06 | 0.6350E-06 | 0.1244E-06 | -0.4607E-06 | 0.1699E-03 | 9 | 6 |
| 1050 | 3 | 0.7000E+01 | 0.1585E-07 | 0.1778E-08 | 0.3996E-06 | 0.5853E-06 | 0.2710E-07 | 0.7280E-04 | 19 | 2 |
| 1100 | 1 | 0.7000E+01 | 0.2842E-07 | -0.3462E-06 | 0.4685E-06 | -0.1828E-05 | -0.2810E-06 | 0.8325E-04 | 5 | 5 |
| 1100 | 2 | 0.7000E+01 | 0.2697E-07 | -0.3463E-06 | 0.4384E-06 | 0.2527E-06 | -0.2809E-06 | 0.1123E-03 | 9 | 6 |
| 1100 | 3 | 0.7000E+01 | 0.1169E-07 | 0.7144E-08 | 0.2805E-06 | 0.2262E-06 | 0.2601E-07 | 0.5247E-04 | 2 | 2 |
| 1150 | 1 | 0.7000E+01 | 0.1974E-07 | -0.2275E-06 | 0.3192E-06 | 0.2644E-06 | -0.1887E-06 | 0.6944E-04 | 6 | 5 |
| 1150 | 2 | 0.7000E+01 | 0.1888E-07 | -0.2043E-06 | 0.3232E-06 | 0.2243E-06 | -0.1615E-06 | 0.8617E-04 | 9 | 6 |
| 1150 | 3 | 0.7000E+01 | 0.1015E-07 | 0.1313E-07 | 0.2149E-06 | 0.8400E-07 | 0.3237E-07 | 0.3926E-04 | 2 | 6 |
| 1200 | 1 | 0.7000E+01 | 0.1406E-07 | -0.1219E-06 | 0.2604E-06 | 0.1162E-05 | -0.9467E-07 | 0.4130E-04 | 5 | 4 |
| 1200 | 2 | 0.7000E+01 | 0.1312E-07 | -0.1293E-06 | 0.2503E-06 | -0.1886E-06 | -0.8893E-07 | 0.4902E-04 | 9 | 6 |
| 1200 | 3 | 0.7000E+01 | 0.8639E-08 | 0.1902E-07 | 0.1601E-06 | 0.1621E-06 | 0.3320E-07 | 0.3223E-04 | 19 | 2 |
| 1250 | 1 | 0.7000E+01 | 0.1027E-07 | -0.7521E-07 | 0.1738E-06 | -0.1590E-05 | -0.6239E-07 | 0.4142E-04 | 5 | 5 |
| 1250 | 2 | 0.7000E+01 | 0.1004E-07 | -0.7810E-07 | 0.1693E-06 | 0.6888E-07 | -0.6451E-07 | 0.3528E-04 | 7 | 2 |
| 1250 | 3 | 0.7000E+01 | 0.8151E-08 | 0.1384E-07 | 0.1301E-06 | 0.1586E-06 | 0.2582E-07 | 0.2693E-04 | 19 | 2 |
| 1300 | 1 | 0.7000E+01 | 0.9433E-08 | -0.4188E-07 | 0.1507E-06 | 0.5107E-06 | -0.7873E-08 | 0.3077E-04 | 8 | 2 |
| 1300 | 2 | 0.7000E+01 | 0.9506E-08 | -0.3784E-07 | 0.1512E-06 | -0.1131E-06 | -0.1132E-07 | 0.3496E-04 | 10 | 3 |
| 1300 | 3 | 0.7000E+01 | 0.7731E-08 | 0.2462E-07 | 0.9242E-07 | 0.2984E-06 | 0.3020E-07 | 0.2319E-04 | 4 | 7 |
| 1350 | 1 | 0.7000E+01 | 0.9859E-08 | 0.1512E-07 | 0.1479E-06 | 0.1474E-06 | 0.3128E-07 | 0.3089E-04 | 7 | 5 |
| 1350 | 2 | 0.7000E+01 | 0.9435E-08 | -0.3337E-08 | 0.1068E-06 | 0.5797E-06 | 0.3361E-08 | 0.4177E-04 | 7 | 2 |
| 1350 | 3 | 0.7000E+01 | 0.7607E-08 | 0.1944E-07 | 0.7900E-07 | 0.1042E-08 | 0.3150E-07 | 0.2102E-04 | 2 | 8 |
| 1400 | 1 | 0.7000E+01 | 0.9041E-08 | 0.1043E-07 | 0.1006E-06 | 0.5013E-06 | 0.2023E-07 | 0.3104E-04 | 2 | 5 |
| 1400 | 2 | 0.7000E+01 | 0.8073E-08 | 0.2923E-08 | 0.8865E-07 | 0.2529E-06 | 0.5704E-08 | 0.2488E-04 | 3 | 6 |
| 1400 | 3 | 0.7000E+01 | 0.6931E-08 | 0.1893E-07 | 0.6431E-07 | 0.1009E-06 | 0.2907E-07 | 0.2270E-04 | 2 | 10 |
| 1450 | 1 | 0.7000E+01 | 0.8447E-08 | 0.4687E-07 | 0.1033E-06 | 0.5013E-06 | 0.6216E-07 | 0.3772E-04 | 3 | 5 |
| 1450 | 2 | 0.7000E+01 | 0.8176E-08 | 0.3720E-07 | 0.9562E-07 | -0.5765E-07 | 0.4200E-07 | 0.2436E-04 | 4 | 2 |
| 1450 | 3 | 0.7000E+01 | 0.7915E-08 | 0.2451E-07 | 0.6961E-07 | 0.2213E-06 | 0.3547E-07 | 0.2424E-04 | 8 | 5 |
| 1500 | 1 | 0.7000E+01 | 0.7321E-08 | 0.4895E-07 | 0.8896E-07 | -0.1184E-05 | 0.5608E-07 | 0.2981E-04 | 8 | 5 |
| 1500 | 2 | 0.7000E+01 | 0.7709E-08 | 0.2882E-07 | 0.7429E-07 | 0.1289E-06 | 0.2999E-07 | 0.2313E-04 | 10 | 6 |
| 1500 | 3 | 0.7000E+01 | 0.7281E-08 | 0.2648E-07 | 0.7670E-07 | -0.4503E-07 | 0.3543E-07 | 0.2527E-04 | 15 | 5 |
| 1550 | 1 | 0.7000E+01 | 0.8603E-08 | 0.3134E-07 | 0.6653E-07 | -0.7527E-06 | 0.3107E-07 | 0.2960E-04 | 6 | 3 |
| 1550 | 2 | 0.7000E+01 | 0.8475E-08 | 0.4115E-07 | 0.7538E-07 | -0.1042E-06 | 0.4130E-07 | 0.3993E-04 | 5 | 3 |
| 1550 | 3 | 0.7000E+01 | 0.7051E-08 | 0.2256E-07 | 0.6223E-07 | 0.1048E-06 | 0.3058E-07 | 0.2552E-04 | 2 | 10 |
| 1600 | 1 | 0.7000E+01 | 0.8325E-08 | 0.4601E-07 | 0.7271E-07 | -0.4226E-06 | 0.4599E-07 | 0.3287E-04 | 6 | 5 |
| 1600 | 2 | 0.7000E+01 | 0.7300E-08 | 0.3777E-07 | 0.6644E-07 | 0.3132E-07 | 0.3915E-07 | 0.3650E-04 | 8 | 3 |
| 1600 | 3 | 0.7000E+01 | 0.7113E-08 | 0.2339E-07 | 0.5933E-07 | 0.4150E-07 | 0.3181E-07 | 0.2629E-04 | 11 | 2 |
| 1650 | 1 | 0.7000E+01 | 0.7012E-08 | 0.3946E-07 | 0.7240E-07 | 0.1224E-05 | 0.3937E-07 | 0.3112E-04 | 2 | 2 |
| 1650 | 2 | 0.7000E+01 | 0.7539E-08 | 0.3965E-07 | 0.6758E-07 | -0.6804E-07 | 0.4127E-07 | 0.2560E-04 | 9 | 2 |
| 1650 | 3 | 0.7000E+01 | 0.6605E-08 | 0.1961E-07 | 0.4553E-07 | 0.9273E-07 | 0.2476E-07 | 0.2627E-04 | 2 | 8 |
| 1700 | 1 | 0.7000E+01 | 0.6995E-08 | 0.3864E-07 | 0.7143E-07 | 0.1216E-05 | 0.3850E-07 | 0.3112E-04 | 2 | 2 |
| 1700 | 2 | 0.7000E+01 | 0.7574E-08 | 0.3987E-07 | 0.6768E-07 | -0.5282E-07 | 0.4166E-07 | 0.2563E-04 | 9 | 2 |
| 1700 | 3 | 0.7000E+01 | 0.6552E-08 | 0.2147E-07 | 0.5288E-07 | 0.9150E-07 | 0.2714E-07 | 0.2148E-04 | 2 | 8 |

Listing E-9. Continued

| BLOCK 1 VARIABLES AT K = 2 | | | | ITERATION NUMBER: 2500 | | | | |
|----------------------------|------------|-------------|-------------|------------------------|------------|-------------|------------|------------|
| J | PRESSURE | TEMPERATURE | MACH NUMBER | TOTAL PRESS | U-COSINE | V-COSINE | X | Y |
| 2 | 0.1011E+02 | 0.5360E+03 | 0.7731E+00 | 0.1500E+02 | 0.1000E+01 | -0.9609E-05 | 0.2500E+00 | 0.1000E+00 |
| 4 | 0.1011E+02 | 0.5360E+03 | 0.7728E+00 | 0.1501E+02 | 0.1000E+01 | 0.1537E-04 | 0.7500E+00 | 0.1000E+00 |
| 6 | 0.1014E+02 | 0.5364E+03 | 0.7701E+00 | 0.1501E+02 | 0.1000E+01 | 0.4184E-03 | 0.1250E+01 | 0.1000E+00 |
| 8 | 0.1030E+02 | 0.5390E+03 | 0.7526E+00 | 0.1500E+02 | 0.1000E+01 | 0.3360E-02 | 0.1750E+01 | 0.1000E+00 |
| 10 | 0.1093E+02 | 0.5482E+03 | 0.6859E+00 | 0.1498E+02 | 0.9999E+00 | 0.1242E-01 | 0.2250E+01 | 0.1062E+00 |
| 12 | 0.1197E+02 | 0.5627E+03 | 0.5770E+00 | 0.1500E+02 | 0.9998E+00 | 0.2040E-01 | 0.2750E+01 | 0.1187E+00 |
| 14 | 0.1263E+02 | 0.5714E+03 | 0.5008E+00 | 0.1499E+02 | 0.9997E+00 | 0.2427E-01 | 0.3250E+01 | 0.1312E+00 |
| BLOCK 1 VARIABLES AT K = 4 | | | | ITERATION NUMBER: 2500 | | | | |
| J | PRESSURE | TEMPERATURE | MACH NUMBER | TOTAL PRESS | U-COSINE | V-COSINE | X | Y |
| 2 | 0.1011E+02 | 0.5360E+03 | 0.7731E+00 | 0.1500E+02 | 0.1000E+01 | -0.2441E-04 | 0.2500E+00 | 0.3000E+00 |
| 4 | 0.1011E+02 | 0.5360E+03 | 0.7730E+00 | 0.1501E+02 | 0.1000E+01 | 0.3989E-04 | 0.7500E+00 | 0.3000E+00 |
| 6 | 0.1013E+02 | 0.5363E+03 | 0.7711E+00 | 0.1501E+02 | 0.1000E+01 | 0.1163E-02 | 0.1250E+01 | 0.3000E+00 |
| 8 | 0.1026E+02 | 0.5383E+03 | 0.7571E+00 | 0.1500E+02 | 0.9999E+00 | 0.1035E-01 | 0.1750E+01 | 0.3000E+00 |
| 10 | 0.1086E+02 | 0.5472E+03 | 0.6918E+00 | 0.1495E+02 | 0.9989E+00 | 0.4626E-01 | 0.2250E+01 | 0.3187E+00 |
| 12 | 0.1197E+02 | 0.5627E+03 | 0.5760E+00 | 0.1499E+02 | 0.9978E+00 | 0.6672E-01 | 0.2750E+01 | 0.3562E+00 |
| 14 | 0.1264E+02 | 0.5715E+03 | 0.4992E+00 | 0.1499E+02 | 0.9973E+00 | 0.7310E-01 | 0.3250E+01 | 0.3937E+00 |
| BLOCK 2 VARIABLES AT K = 2 | | | | ITERATION NUMBER: 2500 | | | | |
| J | PRESSURE | TEMPERATURE | MACH NUMBER | TOTAL PRESS | U-COSINE | V-COSINE | X | Y |
| 2 | 0.1011E+02 | 0.5360E+03 | 0.7732E+00 | 0.1501E+02 | 0.1000E+01 | -0.3315E-04 | 0.2500E+00 | 0.5000E+00 |
| 4 | 0.1011E+02 | 0.5360E+03 | 0.7733E+00 | 0.1501E+02 | 0.1000E+01 | 0.2101E-04 | 0.7500E+00 | 0.5000E+00 |
| 6 | 0.1011E+02 | 0.5361E+03 | 0.7731E+00 | 0.1501E+02 | 0.1000E+01 | 0.1329E-02 | 0.1250E+01 | 0.5000E+00 |
| 8 | 0.1017E+02 | 0.5370E+03 | 0.7669E+00 | 0.1501E+02 | 0.9999E+00 | 0.1477E-01 | 0.1750E+01 | 0.5000E+00 |
| 10 | 0.1071E+02 | 0.5451E+03 | 0.7043E+00 | 0.1492E+02 | 0.9966E+00 | 0.8287E-01 | 0.2250E+01 | 0.5312E+00 |
| 12 | 0.1198E+02 | 0.5629E+03 | 0.5741E+00 | 0.1498E+02 | 0.9934E+00 | 0.1146E+00 | 0.2750E+01 | 0.5937E+00 |
| 14 | 0.1267E+02 | 0.5719E+03 | 0.4961E+00 | 0.1498E+02 | 0.9924E+00 | 0.1227E+00 | 0.3250E+01 | 0.6562E+00 |
| BLOCK 2 VARIABLES AT K = 4 | | | | ITERATION NUMBER: 2500 | | | | |
| J | PRESSURE | TEMPERATURE | MACH NUMBER | TOTAL PRESS | U-COSINE | V-COSINE | X | Y |
| 2 | 0.1011E+02 | 0.5360E+03 | 0.7733E+00 | 0.1501E+02 | 0.1000E+01 | -0.2957E-04 | 0.2500E+00 | 0.7000E+00 |
| 4 | 0.1011E+02 | 0.5360E+03 | 0.7736E+00 | 0.1501E+02 | 0.1000E+01 | -0.2110E-04 | 0.7500E+00 | 0.7000E+00 |
| 6 | 0.1009E+02 | 0.5358E+03 | 0.7755E+00 | 0.1502E+02 | 0.1000E+01 | 0.7721E-03 | 0.1250E+01 | 0.7000E+00 |
| 8 | 0.1003E+02 | 0.5348E+03 | 0.7831E+00 | 0.1504E+02 | 0.9999E+00 | 0.1356E-01 | 0.1750E+01 | 0.7000E+00 |
| 10 | 0.1047E+02 | 0.5418E+03 | 0.7223E+00 | 0.1482E+02 | 0.9922E+00 | 0.1248E+00 | 0.2250E+01 | 0.7437E+00 |
| 12 | 0.1202E+02 | 0.5636E+03 | 0.5702E+00 | 0.1499E+02 | 0.9863E+00 | 0.1650E+00 | 0.2750E+01 | 0.8312E+00 |
| 14 | 0.1271E+02 | 0.5726E+03 | 0.4914E+00 | 0.1499E+02 | 0.9850E+00 | 0.1725E+00 | 0.3250E+01 | 0.9187E+00 |
| BLOCK 3 VARIABLES AT K = 2 | | | | ITERATION NUMBER: 2500 | | | | |
| J | PRESSURE | TEMPERATURE | MACH NUMBER | TOTAL PRESS | U-COSINE | V-COSINE | X | Y |
| 1 | 0.1263E+02 | 0.5714E+03 | 0.5008E+00 | 0.1499E+02 | 0.9997E+00 | 0.2427E-01 | 0.3250E+01 | 0.1312E+00 |
| 3 | 0.1310E+02 | 0.5774E+03 | 0.4437E+00 | 0.1499E+02 | 0.9997E+00 | 0.2543E-01 | 0.3750E+01 | 0.1437E+00 |
| 5 | 0.1343E+02 | 0.5815E+03 | 0.4003E+00 | 0.1499E+02 | 0.9997E+00 | 0.2533E-01 | 0.4250E+01 | 0.1562E+00 |
| 7 | 0.1367E+02 | 0.5844E+03 | 0.3662E+00 | 0.1499E+02 | 0.9997E+00 | 0.2440E-01 | 0.4750E+01 | 0.1687E+00 |
| 9 | 0.1384E+02 | 0.5865E+03 | 0.3396E+00 | 0.1499E+02 | 0.9997E+00 | 0.2239E-01 | 0.5250E+01 | 0.1812E+00 |
| 11 | 0.1397E+02 | 0.5880E+03 | 0.3198E+00 | 0.1499E+02 | 0.9998E+00 | 0.1883E-01 | 0.5750E+01 | 0.1937E+00 |
| 13 | 0.1405E+02 | 0.5890E+03 | 0.3066E+00 | 0.1499E+02 | 0.9999E+00 | 0.1296E-01 | 0.6250E+01 | 0.2000E+00 |
| 15 | 0.1409E+02 | 0.5895E+03 | 0.2992E+00 | 0.1499E+02 | 0.1000E+01 | 0.7631E-02 | 0.6750E+01 | 0.2000E+00 |
| 17 | 0.1411E+02 | 0.5898E+03 | 0.2953E+00 | 0.1499E+02 | 0.1000E+01 | 0.4013E-02 | 0.7250E+01 | 0.2000E+00 |
| 19 | 0.1412E+02 | 0.5898E+03 | 0.2932E+00 | 0.1499E+02 | 0.1000E+01 | 0.1944E-02 | 0.7750E+01 | 0.2000E+00 |

Listing E-9. Concluded

| BLOCK 3 VARIABLES AT K = 4 | | | | ITERATION NUMBER: | | 2500 | | | |
|----------------------------|------------|-------------|-------------|-------------------|------------|------------|------------|------------|--|
| J | PRESSURE | TEMPERATURE | MACH NUMBER | TOTAL PRESS | U-COSINE | V-COSINE | X | Y | |
| 1 | 0.1264E+02 | 0.5715E+03 | 0.4992E+00 | 0.1499E+02 | 0.9973E+00 | 0.7310E-01 | 0.3250E+01 | 0.3937E+00 | |
| 3 | 0.1311E+02 | 0.5776E+03 | 0.4420E+00 | 0.1499E+02 | 0.9972E+00 | 0.7453E-01 | 0.3750E+01 | 0.4312E+00 | |
| 5 | 0.1344E+02 | 0.5816E+03 | 0.3986E+00 | 0.1499E+02 | 0.9973E+00 | 0.7384E-01 | 0.4250E+01 | 0.4687E+00 | |
| 7 | 0.1368E+02 | 0.5846E+03 | 0.3644E+00 | 0.1499E+02 | 0.9975E+00 | 0.7119E-01 | 0.4750E+01 | 0.5062E+00 | |
| 9 | 0.1386E+02 | 0.5867E+03 | 0.3375E+00 | 0.1500E+02 | 0.9979E+00 | 0.6523E-01 | 0.5250E+01 | 0.5437E+00 | |
| 11 | 0.1399E+02 | 0.5883E+03 | 0.3172E+00 | 0.1500E+02 | 0.9985E+00 | 0.5397E-01 | 0.5750E+01 | 0.5812E+00 | |
| 13 | 0.1407E+02 | 0.5893E+03 | 0.3042E+00 | 0.1500E+02 | 0.9994E+00 | 0.3489E-01 | 0.6250E+01 | 0.6000E+00 | |
| 15 | 0.1410E+02 | 0.5897E+03 | 0.2980E+00 | 0.1500E+02 | 0.9998E+00 | 0.1936E-01 | 0.6750E+01 | 0.6000E+00 | |
| 17 | 0.1412E+02 | 0.5899E+03 | 0.2951E+00 | 0.1500E+02 | 0.1000E+01 | 0.9801E-02 | 0.7250E+01 | 0.6000E+00 | |
| 19 | 0.1412E+02 | 0.5899E+03 | 0.2937E+00 | 0.1500E+02 | 0.1000E+01 | 0.4706E-02 | 0.7750E+01 | 0.6000E+00 | |

| BLOCK 3 VARIABLES AT K = 6 | | | | ITERATION NUMBER: | | 2500 | | | |
|----------------------------|------------|-------------|-------------|-------------------|------------|------------|------------|------------|--|
| J | PRESSURE | TEMPERATURE | MACH NUMBER | TOTAL PRESS | U-COSINE | V-COSINE | X | Y | |
| 1 | 0.1267E+02 | 0.5719E+03 | 0.4961E+00 | 0.1498E+02 | 0.9924E+00 | 0.1227E+00 | 0.3250E+01 | 0.6562E+00 | |
| 3 | 0.1314E+02 | 0.5779E+03 | 0.4390E+00 | 0.1499E+02 | 0.9923E+00 | 0.1239E+00 | 0.3750E+01 | 0.7187E+00 | |
| 5 | 0.1346E+02 | 0.5819E+03 | 0.3957E+00 | 0.1500E+02 | 0.9925E+00 | 0.1224E+00 | 0.4250E+01 | 0.7812E+00 | |
| 7 | 0.1370E+02 | 0.5849E+03 | 0.3611E+00 | 0.1500E+02 | 0.9930E+00 | 0.1184E+00 | 0.4750E+01 | 0.8437E+00 | |
| 9 | 0.1389E+02 | 0.5871E+03 | 0.3330E+00 | 0.1500E+02 | 0.9940E+00 | 0.1095E+00 | 0.5250E+01 | 0.9062E+00 | |
| 11 | 0.1403E+02 | 0.5888E+03 | 0.3108E+00 | 0.1500E+02 | 0.9959E+00 | 0.9086E-01 | 0.5750E+01 | 0.9687E+00 | |
| 13 | 0.1411E+02 | 0.5898E+03 | 0.2975E+00 | 0.1501E+02 | 0.9985E+00 | 0.5404E-01 | 0.6250E+01 | 0.1000E+01 | |
| 15 | 0.1413E+02 | 0.5900E+03 | 0.2939E+00 | 0.1500E+02 | 0.9996E+00 | 0.2722E-01 | 0.6750E+01 | 0.1000E+01 | |
| 17 | 0.1413E+02 | 0.5900E+03 | 0.2929E+00 | 0.1500E+02 | 0.9999E+00 | 0.1277E-01 | 0.7250E+01 | 0.1000E+01 | |
| 19 | 0.1413E+02 | 0.5901E+03 | 0.2925E+00 | 0.1500E+02 | 0.1000E+01 | 0.5931E-02 | 0.7750E+01 | 0.1000E+01 | |

| BLOCK 3 VARIABLES AT K = 8 | | | | ITERATION NUMBER: | | 2500 | | | |
|----------------------------|------------|-------------|-------------|-------------------|------------|------------|------------|------------|--|
| J | PRESSURE | TEMPERATURE | MACH NUMBER | TOTAL PRESS | U-COSINE | V-COSINE | X | Y | |
| 1 | 0.1271E+02 | 0.5726E+03 | 0.4914E+00 | 0.1499E+02 | 0.9850E+00 | 0.1725E+00 | 0.3250E+01 | 0.9187E+00 | |
| 3 | 0.1317E+02 | 0.5785E+03 | 0.4334E+00 | 0.1499E+02 | 0.9849E+00 | 0.1730E+00 | 0.3750E+01 | 0.1006E+01 | |
| 5 | 0.1350E+02 | 0.5825E+03 | 0.3892E+00 | 0.1498E+02 | 0.9852E+00 | 0.1714E+00 | 0.4250E+01 | 0.1094E+01 | |
| 7 | 0.1374E+02 | 0.5855E+03 | 0.3531E+00 | 0.1497E+02 | 0.9858E+00 | 0.1676E+00 | 0.4750E+01 | 0.1181E+01 | |
| 9 | 0.1393E+02 | 0.5879E+03 | 0.3222E+00 | 0.1497E+02 | 0.9874E+00 | 0.1585E+00 | 0.5250E+01 | 0.1269E+01 | |
| 11 | 0.1409E+02 | 0.5898E+03 | 0.2955E+00 | 0.1497E+02 | 0.9908E+00 | 0.1350E+00 | 0.5750E+01 | 0.1356E+01 | |
| 13 | 0.1419E+02 | 0.5909E+03 | 0.2814E+00 | 0.1499E+02 | 0.9977E+00 | 0.6799E-01 | 0.6250E+01 | 0.1400E+01 | |
| 15 | 0.1417E+02 | 0.5907E+03 | 0.2828E+00 | 0.1497E+02 | 0.9996E+00 | 0.2932E-01 | 0.6750E+01 | 0.1400E+01 | |
| 17 | 0.1415E+02 | 0.5905E+03 | 0.2851E+00 | 0.1497E+02 | 0.9999E+00 | 0.1227E-01 | 0.7250E+01 | 0.1400E+01 | |
| 19 | 0.1414E+02 | 0.5905E+03 | 0.2868E+00 | 0.1497E+02 | 0.1000E+01 | 0.5183E-02 | 0.7750E+01 | 0.1400E+01 | |

| BLOCK 3 VARIABLES AT K = 10 | | | | ITERATION NUMBER: | | 2500 | | | |
|-----------------------------|------------|-------------|-------------|-------------------|------------|------------|------------|------------|--|
| J | PRESSURE | TEMPERATURE | MACH NUMBER | TOTAL PRESS | U-COSINE | V-COSINE | X | Y | |
| 1 | 0.1277E+02 | 0.5739E+03 | 0.4741E+00 | 0.1489E+02 | 0.9743E+00 | 0.2253E+00 | 0.3250E+01 | 0.1181E+01 | |
| 3 | 0.1322E+02 | 0.5796E+03 | 0.4190E+00 | 0.1492E+02 | 0.9746E+00 | 0.2238E+00 | 0.3750E+01 | 0.1294E+01 | |
| 5 | 0.1354E+02 | 0.5834E+03 | 0.3767E+00 | 0.1493E+02 | 0.9751E+00 | 0.2219E+00 | 0.4250E+01 | 0.1406E+01 | |
| 7 | 0.1378E+02 | 0.5864E+03 | 0.3415E+00 | 0.1493E+02 | 0.9756E+00 | 0.2195E+00 | 0.4750E+01 | 0.1519E+01 | |
| 9 | 0.1398E+02 | 0.5888E+03 | 0.3092E+00 | 0.1494E+02 | 0.9768E+00 | 0.2141E+00 | 0.5250E+01 | 0.1631E+01 | |
| 11 | 0.1418E+02 | 0.5912E+03 | 0.2739E+00 | 0.1493E+02 | 0.9796E+00 | 0.2009E+00 | 0.5750E+01 | 0.1744E+01 | |
| 13 | 0.1431E+02 | 0.5927E+03 | 0.2614E+00 | 0.1500E+02 | 0.9981E+00 | 0.6211E-01 | 0.6250E+01 | 0.1800E+01 | |
| 15 | 0.1420E+02 | 0.5914E+03 | 0.2766E+00 | 0.1498E+02 | 0.9999E+00 | 0.1253E-01 | 0.6750E+01 | 0.1800E+01 | |
| 17 | 0.1416E+02 | 0.5909E+03 | 0.2824E+00 | 0.1496E+02 | 0.1000E+01 | 0.2375E-02 | 0.7250E+01 | 0.1800E+01 | |
| 19 | 0.1414E+02 | 0.5908E+03 | 0.2848E+00 | 0.1496E+02 | 0.1000E+01 | 0.8552E-03 | 0.7750E+01 | 0.1800E+01 | |

Listing E-10. Grid and Initial Condition Generator (Refined Block)

```

1  1.  PROGRAM ICFILE
2  2.  PARAMETER(JD=33,KD=11)
3  3.  DIMENSION R(JD,KD),RU(JD,KD),RV(JD,KD),E(JD,KD)
4  4.  DIMENSION X(JD,KD),Y(JD,KD)
5  5.  DIMENSION RA(29,13),RUA(29,13),RVA(29,13),EA(29,13)
6  6.  DIMENSION XA(29,13),YA(29,13)
7  7.  DATA G/1.4/
8  8.  GM1=G-1.
9  9.  DELX=B./32
10 10.  C FORM THE 'X' GRID ARRAY
11 11.  DO 1 J=1,JD
12 12.  DO 1 K=1,KD
13 13.  IF(J.EQ.1) THEN
14 14.  X(J,K)=0.
15 15.  ELSE
16 16.  X(J,K)=X(J-1,K)+DELX
17 17.  ENDIF
18 18. 1 CONTINUE
19 19.  C FORM THE 'Y' GRID ARRAYS
20 20.  DO 2 J=1,JD
21 21.  IF(X(J,KD).LE.2.) YO=1.
22 22.  IF(X(J,KD).GT.6.) YO=2.
23 23.  IF((X(J,KD).GT.2.) .AND. (X(J,KD).LE.6.)) THEN
24 24.  YO=1.+(X(J,KD)-2.)*0.25
25 25.  ENDF
26 26.  DELY=YO/(KD-1)
27 27.  Y(J,1)=0.0
28 28.  DO 2 K=2,KD
29 29.  Y(J,K)=Y(J,K-1)+DELY
30 30. 2 CONTINUE
31 31.  C FORM THE ARRAYS OF NON-DIMENSIONAL CONSERVATION VARIABLES
32 32.  C CONSISTENT WITH A FREE-STREAM MACH NUMBER OF 0.29
33 33.  FMACH=0.29
34 34.  FACT=(1.+2*FMACH**2)
35 35.  PBAR=FACT**(-3.5)/G
36 36.  DO 1000 J=1,JD
37 37.  DO 2000 K=1,KD
38 38.  R(J,K)=FACT**(-2.5)
39 39.  RU(J,K)=R(J,K)*FMACH*SQRT(1./FACT)
40 40.  RV(J,K)=0.
41 41.  E(J,K)=PBAR/GM1+.5*(RU(J,K)**2)/R(J,K)
42 42. 2000 CONTINUE
43 43. 1000 CONTINUE
44 44.  DO 10 K=5,11
45 45.  KA=2*(K-5)+1
46 46.  DO 10 J=1,15
47 47.  JA=2*(J-1)+1
48 48.  XA(JA,KA)=X(J,K)
49 49.  YA(JA,KA)=Y(J,K)
50 50.  RA(JA,KA)=R(J,K)
51 51.  RUA(JA,KA)=RU(J,K)
52 52.  RVA(JA,KA)=RV(J,K)
53 53. 10 EA(JA,KA)=E(J,K)
54 54.  DO 20 K=1,13,2
55 55.  DO 20 J=2,28,2
56 56.  XA(J,K)=.5*(XA(J-1,K)+XA(J+1,K))
57 57.  YA(J,K)=.5*(YA(J-1,K)+YA(J+1,K))
58 58.  RA(J,K)=.5*(RA(J-1,K)+RA(J+1,K))
59 59.  RUA(J,K)=.5*(RUA(J-1,K)+RUA(J+1,K))
60 60.  RVA(J,K)=.5*(RVA(J-1,K)+RVA(J+1,K))
61 61. 20 EA(J,K)=.5*(EA(J-1,K)+EA(J+1,K))
62 62.  DO 30 K=2,12,2
63 63.  DO 30 J=1,29
64 64.  XA(J,K)=.5*(XA(J,K-1)+XA(J,K+1))
65 65.  YA(J,K)=.5*(YA(J,K-1)+YA(J,K+1))
66 66.  RA(J,K)=.5*(RA(J,K-1)+RA(J,K+1))
67 67.  RUA(J,K)=.5*(RUA(J,K-1)+RUA(J,K+1))
68 68.  RVA(J,K)=.5*(RVA(J,K-1)+RVA(J,K+1))
69 69. 30 EA(J,K)=.5*(EA(J,K-1)+EA(J,K+1))

```

.Listing E-10. Concluded

```

70 66.      NC1=0
71 67.      WRITE(20)NC1,G
72 68.      WRITE(20)15,6
73 69.      WRITE(20)(( X(J,K),J= 1,15),K=1, 6),
74          *      (( Y(J,K),J= 1,15),K=1, 6)
75 70.      WRITE(20)(( R(J,K),J= 1,15),K=1, 6),
76          =      ((RU(J,K),J= 1,15),K=1, 6),
77          *      ((RV(J,K),J= 1,15),K=1, 6),
78          *      (( E(J,K),J= 1,15),K=1, 6)
79 71.      WRITE(20)29,13
80 72.      WRITE(20)XA,YA
81 73.      WRITE(20)RA,RUA,RVA,EA
82 74.      WRITE(20)20,11
83 75.      WRITE(20)(( X(J,K),J=14,33),K=1,11),
84          *      (( Y(J,K),J=14,33),K=1,11)
85 76.      WRITE(20)(( R(J,K),J=14,33),K=1,11),
86          *      ((RU(J,K),J=14,33),K=1,11),
87          *      ((RV(J,K),J=14,33),K=1,11),
88          *      (( E(J,K),J=14,33),K=1,11)
89 77.      STOP
90 78.      END

```

Listing E-11. Execution and Input File (Refined Block)

```

//A05569X JOB (SVT,ATT00000,00,78904912),'DCM TODD EL2 CFD',
// CLASS=X,TIME=(,5),USER=A05569,PASSWORD=XXXXXXXXX,MSGCLASS=Z,
// MSGLEVEL=1,PRTY=8,NOTIFY=A05569
/**
/*ROUTE PRINT RMTD
/*JOBPARM ROOM=5 2ND FLOOR DO BLDG 1099
/**
// EXEC CRAY
CRSUBMIT F(OSJOB) NOTIFY(A05569) DEST(RMTD) PRINT(3) HOLD
//OSJOB DD *
JOB,JN=A05569Y,T=150,MFL.
ACCOUNT,AC=78904910,US=A05569.
FETCH,DN=CODE,TEXT='DSN=A05569.BARC(BARC2D),DISP=SHR'.
CFT,I=CODE,L=0.
ACCESS,DN=BNCHLIB,PDN=BNCHLIB,ID=BNCHMRK,OWN=SYSTEM.
ACCESS,DN=FT02,PDN=1CCASE4.
LDR,LIB=BNCHLIB.
*SAVE,DN=FT04,PDN=RSCASE4.
DISPOSE,DN=FT04,DC=ST,DF=TR,TEXT='
'DSN=A05569.TRCASE4.REST,DISP=(,CATLG),'
'UNIT=DISK,SPACE=(CYL,(38),RLSE),'
'DCB=(RECFM=F,LRECL=4096,BLKSIZE=4096)'.
/EOF
$IMPUTS
  NMAX=2500,      NP=2500,
  PREF=15.0,     TREFR=600.,
  IFXPRT=1,      NBLOCK=3,
  DIS2=0.00,     DIS4=0.30,
  DTCAP= 7.0,    PCOMAX=10.0,
  NSPRT=50,      IAXISY=0,      STOPL2=1.E-20,
$
$BLOCK :#1
  NPSEG=1,
  INVISC(1)=0,   INVISC(2)=0,
$
$PRTSEG
  JKLP1(1,1,1)=2,14,2,      JKLP1(1,2,1)=2,4,2,      IPORD(1)=1,
$
$BOUNDS
  NJSEG=2,
  JLINE(1)=1,
  JKLOW(1)=2,  JKHIGH(1)=5,      JTYPE(1)=0,
  JSIGN(1)=1,  PRESSJ(1)=0.7142857,  TEMPJ(1)=1.0,
  JLINE(2)=15,
  JKLOW(2)=2,  JKHIGH(2)=6,      JTYPE(2)=71,
  JSIGN(2)=-1,  INTERJ(2)=1,
  NKSEG=2,
  KLINE(1)=1,
  KJLOW(1)=1,  KJHIGH(1)=15,     KTYPE(1)=50,
  KSIGN(1)=1,
  KLINE(2)=6,
  KJLOW(2)=1,  KJHIGH(2)=14,     KTYPE(2)=71,
  KSIGN(2)=-1,  INTERK(2)=2,
$
$BLOCK :#2
  NPSEG=1,
  INVISC(1)=0,   INVISC(2)=0,
$
$PRTSEG
  JKLP1(1,1,1)=3,27,4,      JKLP1(1,2,1)=3,7,4,      IPORD(1)=1,
$

```

Listing E-11. Concluded

```

$BOUNDS
  NJSEG=2,
    JLINE(1)=1,
    JKLOW(1)=2,   JKHIGH(1)=12,   JTYPE(1)=0,
    JSIGN(1)=1,   PRESSJ(1)=0.7142857,   TEMPJ(1)=1.0,
    JLINE(2)=29,
    JKLOW(2)=1,   JKHIGH(2)=12,   JTYPE(2)=71,
    JSIGN(2)=-1,   INTERJ(2)=3,
  NKSEG=2,
    KLINE(1)=1,
    KJLOW(1)=1,   KJHIGH(1)=28,   KTYPE(1)=71,
    KSIGN(1)=1,   INTERK(1)=2,
    KLINE(2)=13,
    KJLOW(2)=1,   KJHIGH(2)=29,   KTYPE(2)=50,
    KSIGN(2)=-1,
$
$BLOCK :#3
  NPSEG=1,
  INVISC(1)=0,   INVISC(2)=0,
$
$SPRTSEG
  JKLPI(1,1,1)=1,19,2,   JKLPI(1,2,1)=2,10,2,   IPORD(1)=1,
$
$BOUNDS
  NJSEG=3,
    JLINE(1)=1,
    JKLOW(1)=2,   JKHIGH(1)=6,   JTYPE(1)=71,
    JSIGN(1)=1,   INTERJ(1)=1,
    JLINE(2)=1,
    JKLOW(2)=5,   JKHIGH(2)=10,   JTYPE(2)=71,
    JSIGN(2)=1,   INTERJ(2)=3,
    JLINE(3)=20,
    JKLOW(3)=2,   JKHIGH(3)=10,   JTYPE(3)=0,
    JSIGN(3)=-1,   PRESSJ(3)=0.67285,   TEMPJ(3)=1.0,
  NKSEG=2,
    KLINE(1)=1,
    KJLOW(1)=1,   KJHIGH(1)=20,   KTYPE(1)=50,
    KSIGN(1)=1,
    KLINE(2)=11,
    KJLOW(2)=1,   KJHIGH(2)=20,   KTYPE(2)=50,
    KSIGN(2)=-1,
$
/EOJ

```

Listing E-12. Output for Refined Block

NAMelist INPUTS:

```

PREF = 0.150000E+02      IAXISY = 0
TREFR = 0.600000E+03     NBLOCK = 3
VRAT = -0.666667E+00     NMAX = 2500
TSUTH = 0.198600E+03     NC = 0
RE = 0.000000E+00       NSPRT = 50
PR = 0.720000E+00       NP = 2500
PRT = 0.900000E+00      IFXPRT = 1
DIS2 = 0.000000E+00     IFXPLY = 0
DIS4 = 0.300000E+00     L2PLOT = 0
DTCAP = 0.700000E+01    IPLOT = 0
PCOMAX = 0.100000E+02   LMODE = 1
SPLEND = 0.100000E+01   MBORD = 3
SMOD = 0.000000E+00     NUMDT = 0
STOPL2 = 0.100000E-19   IVARDT = 2
STOPTR = 0.500000E+01   ISOLVE = 1
ALPHA = 0.000000E+00    IRHS = 1
XMACH = 0.000000E+00    IFILTR = 1
                                IMUTUR = 1
    
```

THE ORDER OF BLOCK PROCESSING FOLLOWS
1, 2, 3

FOR BLOCK 1
JMAX = 15 KMAX = 6
NM = 15 IJK = 90

```

NAMelist BLOCK FOR BLOCK 1
GAMMA = 0.140000E+01     INVISC = 0 0
COFMIX = 0.900000E-01    LAMIN = 0 0
DTBLK = 0.000000E+00     NPSEG = 1
                                NBCSEG = 0
    
```

```

NAMelist PRTSEG FOR BLOCK 1
                                JKLP1
                                IPORD
                                J   K
1      2  14  2      2  4  2      1  2
    
```

```

NAMelist BOUNDS FOR BLOCK 1
JSEG JLINE JKLOW JKHIGH JTYPE INTERJ JSIGN PRESSJ TEMPJ JTYPE
1     1     2     5     0     1     1 0.714286E+00 0.100000E+01 FREE
2     15    2     6     71    1    -1
KSEG KLINE KJLOW KJHIGH KTYPE INTERK KSIGN PRESSK TEMPK KTYPE
1     1     1     15    50    1
2     6     1     14    71    2    -1
                                SLIP
                                NON-CONTIGUOUS
    
```

GRID PATCHES FOR BLOCK 1

```

J-PATCHES  MINIMUM      MAXIMUM
            J   K        J   K
1           2   2        14  5
    
```

```

K-PATCHES  MINIMUM      MAXIMUM
            J   K        J   K
1           2   2        14  5
    
```

FOR BLOCK 2
JMAX = 29 KMAX = 13
NM = 29 IJK = 377

```

NAMelist BLOCK FOR BLOCK 2
GAMMA = 0.140000E+01     INVISC = 0 0
COFMIX = 0.900000E-01    LAMIN = 0 0
DTBLK = 0.000000E+00     NPSEG = 1
                                NBCSEG = 0
    
```

```

NAMelist PRTSEG FOR BLOCK 2
                                JKLP1
                                IPORD
                                J   K
1      3  27  4      3  7  4      1  2
    
```

Listing E-12. Continued

```

NAMELIST BOUNDS FOR BLOCK 2
JSEG JLINE JKLOW JKHIGH JTYPE INTERJ JSIGN PRESSJ TEMPJ JTYPE
1 1 2 12 0 1 0.714286E+00 0.100000E+01 FREE
2 29 1 12 71 3 -1 NON-CONTIGUOUS
KSEG KLINE KJLOW KJHIGH KTYPE INTERK KSIGN PRESSK TENPK KTYPE
1 1 1 28 71 2 1 NON-CONTIGUOUS
2 13 1 29 50 -1 SLIP
GRID PATCHES FOR BLOCK 2

```

```

J-PATCHES MINIMUM MAXIMUM
          J K      J K
1         2 2      28 12

```

```

K-PATCHES MINIMUM MAXIMUM
          J K      J K
1         2 2      28 12

```

FOR BLOCK 3
 JMAX = 20 KMAX = 11
 NM = 20 IJK = 220

```

NAMELIST BLOCK FOR BLOCK 3
GAMMA = 0.140000E+01 INVISC = 0 0
COFNIX = 0.900000E-01 LAMIN = 0 0
DTBLK = 0.000000E+00 NPSEG = 1
NBCSEG = 0

```

```

NAMELIST PRITSEG FOR BLOCK 3
          JKLPI
1         JA JB JS KA KB KS IPORD
          1 19 2 2 10 2 1 2

```

```

NAMELIST BOUNDS FOR BLOCK 3
JSEG JLINE JKLOW JKHIGH JTYPE INTERJ JSIGN PRESSJ TEMPJ JTYPE
1 1 2 6 71 1 1 NON-CONTIGUOUS
2 1 5 10 71 3 1 NON-CONTIGUOUS
3 20 2 10 0 -1 0.672850E+00 0.100000E+01 FREE
KSEG KLINE KJLOW KJHIGH KTYPE INTERK KSIGN PRESSK TENPK KTYPE
1 1 1 20 50 1 1 SLIP
2 11 1 20 50 -1 SLIP

```

GRID PATCHES FOR BLOCK 3

```

J-PATCHES MINIMUM MAXIMUM
          J K      J K
1         2 2      19 10

```

```

K-PATCHES MINIMUM MAXIMUM
          J K      J K
1         2 2      19 10

```

BC TYPE 71 OR 77 PASS FOR BLOCK 1
 JSEG =2 I1 =1 NIPP =5
 KSEG =2 I1 =2 NIPP =28

BC TYPE 71 OR 77 PASS FOR BLOCK 2
 JSEG =2 I1 =3 NIPP =6
 KSEG =1 I1 =-2 NIPP =14

BC TYPE 71 OR 77 PASS FOR BLOCK 3
 JSEG =1 I1 =-1 NIPP =5
 JSEG =2 I1 =-3 NIPP =12

Listing E-12. Continued

| COUNT | BLOCK | DT | L2 RESIDUAL | MASS FLUX | MOMENTUM FLUXES | | ENERGY FLUX | MAX PERCENT VARIATION | MAX LOCATION | |
|-------|-------|------------|-------------|-------------|-----------------|-------------|-------------|-----------------------|--------------|----|
| | | | | | X | Y | | | J | K |
| 50 | 1 | 0.7000E+01 | 0.2377E-03 | -0.9017E-03 | -0.2240E-02 | 0.4463E-01 | -0.1348E-02 | 0.6531E+00 | 14 | 5 |
| 50 | 2 | 0.7000E+01 | 0.1228E-03 | -0.4837E-02 | 0.2186E-02 | 0.8096E-01 | -0.5744E-02 | 0.1493E+01 | 28 | 2 |
| 50 | 3 | 0.7000E+01 | 0.3263E-03 | -0.5890E-03 | 0.4857E-02 | 0.8145E-02 | -0.5930E-03 | 0.1223E+01 | 2 | 6 |
| 100 | 1 | 0.7000E+01 | 0.9847E-04 | 0.4660E-04 | 0.1116E-02 | 0.1650E-01 | 0.2301E-03 | 0.3237E+00 | 14 | 2 |
| 100 | 2 | 0.7000E+01 | 0.4697E-04 | -0.2274E-03 | 0.4204E-02 | 0.1177E-01 | 0.2909E-03 | 0.8809E+00 | 28 | 6 |
| 100 | 3 | 0.7000E+01 | 0.2587E-03 | 0.2436E-03 | 0.2883E-02 | -0.2497E-02 | 0.4744E-03 | 0.7375E+00 | 11 | 2 |
| 150 | 1 | 0.7000E+01 | 0.5897E-04 | -0.5263E-03 | 0.1345E-02 | 0.4064E-03 | -0.4135E-03 | 0.2882E+00 | 14 | 2 |
| 150 | 2 | 0.7000E+01 | 0.2121E-04 | -0.8151E-03 | 0.3090E-02 | -0.1427E-03 | -0.4698E-03 | 0.2898E+00 | 28 | 12 |
| 150 | 3 | 0.7000E+01 | 0.1819E-03 | -0.2865E-04 | 0.6720E-03 | -0.2916E-03 | -0.7000E-05 | 0.4047E+00 | 3 | 6 |
| 200 | 1 | 0.7000E+01 | 0.4141E-04 | -0.5084E-03 | 0.8855E-03 | 0.1073E-02 | -0.4353E-03 | 0.1273E+00 | 14 | 5 |
| 200 | 2 | 0.7000E+01 | 0.1600E-04 | -0.9796E-03 | 0.1730E-02 | 0.1365E-02 | -0.8254E-03 | 0.1887E+00 | 17 | 12 |
| 200 | 3 | 0.7000E+01 | 0.9149E-04 | -0.2343E-04 | 0.4633E-03 | 0.6980E-03 | -0.7005E-05 | 0.2438E+00 | 5 | 5 |
| 250 | 1 | 0.7000E+01 | 0.3002E-04 | -0.3823E-03 | 0.5795E-03 | 0.2204E-03 | -0.3277E-03 | 0.9394E-01 | 14 | 5 |
| 250 | 2 | 0.7000E+01 | 0.1144E-04 | -0.7265E-03 | 0.1124E-02 | 0.5638E-03 | -0.6093E-03 | 0.1454E+00 | 17 | 12 |
| 250 | 3 | 0.7000E+01 | 0.2996E-04 | -0.2537E-04 | 0.3319E-03 | 0.6651E-03 | -0.1510E-04 | 0.7927E-01 | 9 | 2 |
| 300 | 1 | 0.7000E+01 | 0.2236E-04 | -0.2877E-03 | 0.3950E-03 | 0.2939E-03 | -0.2442E-03 | 0.5501E-01 | 14 | 2 |
| 300 | 2 | 0.7000E+01 | 0.8586E-05 | -0.5512E-03 | 0.7799E-03 | 0.4203E-03 | -0.4568E-03 | 0.1172E+00 | 17 | 12 |
| 300 | 3 | 0.7000E+01 | 0.1132E-04 | -0.1032E-04 | 0.2410E-03 | 0.3810E-03 | 0.6336E-06 | 0.5163E-01 | 19 | 10 |
| 350 | 1 | 0.7000E+01 | 0.1724E-04 | -0.2260E-03 | 0.2770E-03 | 0.2181E-03 | -0.1931E-03 | 0.4067E-01 | 9 | 5 |
| 350 | 2 | 0.7000E+01 | 0.6553E-05 | -0.4303E-03 | 0.5421E-03 | 0.2730E-03 | -0.3597E-03 | 0.9024E-01 | 17 | 12 |
| 350 | 3 | 0.7000E+01 | 0.6069E-05 | -0.9151E-05 | 0.1644E-03 | 0.2365E-03 | -0.2052E-05 | 0.3354E-01 | 19 | 10 |
| 400 | 1 | 0.7000E+01 | 0.1309E-04 | -0.1738E-03 | 0.1973E-03 | 0.1182E-03 | -0.1489E-03 | 0.3154E-01 | 9 | 5 |
| 400 | 2 | 0.7000E+01 | 0.4988E-05 | -0.3307E-03 | 0.3820E-03 | 0.1624E-03 | -0.2777E-03 | 0.7354E-01 | 17 | 12 |
| 400 | 3 | 0.7000E+01 | 0.4080E-05 | -0.6754E-05 | 0.1150E-03 | 0.1838E-03 | -0.1745E-05 | 0.2396E-01 | 19 | 10 |
| 450 | 1 | 0.7000E+01 | 0.9894E-05 | -0.1319E-03 | 0.1413E-03 | 0.8497E-04 | -0.1131E-03 | 0.2441E-01 | 9 | 5 |
| 450 | 2 | 0.7000E+01 | 0.3770E-05 | -0.2511E-03 | 0.2747E-03 | 0.1083E-03 | -0.2107E-03 | 0.5714E-01 | 17 | 12 |
| 450 | 3 | 0.7000E+01 | 0.2852E-05 | -0.4677E-05 | 0.8374E-04 | 0.1310E-03 | -0.8423E-06 | 0.1715E-01 | 19 | 10 |
| 500 | 1 | 0.7000E+01 | 0.7513E-05 | -0.1006E-03 | 0.1027E-03 | 0.6208E-04 | -0.8641E-04 | 0.1873E-01 | 9 | 5 |
| 500 | 2 | 0.7000E+01 | 0.2862E-05 | -0.1914E-03 | 0.1993E-03 | 0.7481E-04 | -0.1610E-03 | 0.4410E-01 | 17 | 12 |
| 500 | 3 | 0.7000E+01 | 0.2073E-05 | -0.3445E-05 | 0.6073E-04 | 0.9328E-04 | -0.6196E-06 | 0.1236E-01 | 19 | 10 |
| 550 | 1 | 0.7000E+01 | 0.5693E-05 | -0.7651E-04 | 0.7533E-04 | 0.4219E-04 | -0.6577E-04 | 0.1431E-01 | 9 | 5 |
| 550 | 2 | 0.7000E+01 | 0.2170E-05 | -0.1455E-03 | 0.1458E-03 | 0.5101E-04 | -0.1226E-03 | 0.3408E-01 | 17 | 12 |
| 550 | 3 | 0.7000E+01 | 0.1521E-05 | -0.2554E-05 | 0.4446E-04 | 0.6922E-04 | -0.4635E-06 | 0.9001E-02 | 19 | 10 |
| 600 | 1 | 0.7000E+01 | 0.4309E-05 | -0.5801E-04 | 0.5558E-04 | 0.3145E-04 | -0.4988E-04 | 0.1090E-01 | 9 | 5 |
| 600 | 2 | 0.7000E+01 | 0.1643E-05 | -0.1103E-03 | 0.1076E-03 | 0.3579E-04 | -0.9296E-04 | 0.2613E-01 | 17 | 12 |
| 600 | 3 | 0.7000E+01 | 0.1124E-05 | -0.1876E-05 | 0.3287E-04 | 0.5110E-04 | -0.3104E-06 | 0.6623E-02 | 19 | 10 |
| 650 | 1 | 0.7000E+01 | 0.3263E-05 | -0.4397E-04 | 0.4125E-04 | 0.2491E-04 | -0.3782E-04 | 0.8255E-02 | 9 | 5 |
| 650 | 2 | 0.7000E+01 | 0.1244E-05 | -0.8361E-04 | 0.7978E-04 | 0.2549E-04 | -0.7050E-04 | 0.1993E-01 | 17 | 12 |
| 650 | 3 | 0.7000E+01 | 0.8366E-06 | -0.1392E-05 | 0.2440E-04 | 0.3776E-04 | -0.2206E-06 | 0.4900E-02 | 19 | 10 |
| 700 | 1 | 0.7000E+01 | 0.2468E-05 | -0.3328E-04 | 0.3076E-04 | 0.1592E-04 | -0.2864E-04 | 0.6279E-02 | 9 | 5 |
| 700 | 2 | 0.7000E+01 | 0.9408E-06 | -0.6330E-04 | 0.5943E-04 | 0.1833E-04 | -0.5340E-04 | 0.1518E-01 | 17 | 12 |
| 700 | 3 | 0.7000E+01 | 0.6242E-06 | -0.1033E-05 | 0.1819E-04 | 0.2815E-04 | -0.1544E-06 | 0.3645E-02 | 19 | 10 |
| 750 | 1 | 0.7000E+01 | 0.1867E-05 | -0.2518E-04 | 0.2299E-04 | 0.1107E-04 | -0.2169E-04 | 0.4767E-02 | 9 | 5 |
| 750 | 2 | 0.7000E+01 | 0.7112E-06 | -0.4788E-04 | 0.4445E-04 | 0.1368E-04 | -0.4039E-04 | 0.1155E-01 | 17 | 12 |
| 750 | 3 | 0.7000E+01 | 0.4670E-06 | -0.7682E-06 | 0.1361E-04 | 0.2099E-04 | -0.1051E-06 | 0.2701E-02 | 19 | 10 |
| 800 | 1 | 0.7000E+01 | 0.1411E-05 | -0.1904E-04 | 0.1725E-04 | 0.9739E-05 | -0.1640E-04 | 0.3608E-02 | 4 | 2 |
| 800 | 2 | 0.7000E+01 | 0.5377E-06 | -0.3620E-04 | 0.3332E-04 | 0.9852E-05 | -0.3055E-04 | 0.8760E-02 | 17 | 12 |
| 800 | 3 | 0.7000E+01 | 0.3506E-06 | -0.5689E-06 | 0.1022E-04 | 0.1584E-04 | -0.7088E-07 | 0.2028E-02 | 19 | 10 |
| 850 | 1 | 0.7000E+01 | 0.1065E-05 | -0.1438E-04 | 0.1297E-04 | 0.7170E-05 | -0.1238E-04 | 0.2739E-02 | 9 | 5 |
| 850 | 2 | 0.7000E+01 | 0.4060E-06 | -0.2734E-04 | 0.2505E-04 | 0.7526E-05 | -0.2306E-04 | 0.6622E-02 | 17 | 12 |
| 850 | 3 | 0.7000E+01 | 0.2642E-06 | -0.4217E-06 | 0.7680E-05 | 0.1176E-04 | -0.4588E-07 | 0.1521E-02 | 19 | 10 |

Listing E-12. Continued

| | | | | | | | | | | |
|------|---|------------|------------|-------------|------------|-------------|-------------|------------|----|----|
| 900 | 1 | 0.7000E+01 | 0.8049E-06 | -0.1086E-04 | 0.9770E-05 | 0.5593E-05 | -0.9342E-05 | 0.2072E-02 | 4 | 5 |
| 900 | 2 | 0.7000E+01 | 0.3067E-06 | -0.2065E-04 | 0.1885E-04 | 0.5538E-05 | -0.1742E-04 | 0.4990E-02 | 17 | 12 |
| 900 | 3 | 0.7000E+01 | 0.1984E-06 | -0.3137E-06 | 0.5789E-05 | 0.8916E-05 | -0.2712E-07 | 0.1144E-02 | 19 | 10 |
| 950 | 1 | 0.7000E+01 | 0.6080E-06 | -0.8187E-05 | 0.7374E-05 | 0.3872E-05 | -0.7044E-05 | 0.1571E-02 | 4 | 2 |
| 950 | 2 | 0.7000E+01 | 0.2317E-06 | -0.1559E-04 | 0.1423E-04 | 0.3970E-05 | -0.1315E-04 | 0.3816E-02 | 17 | 12 |
| 950 | 3 | 0.7000E+01 | 0.1498E-06 | -0.2243E-06 | 0.4372E-05 | 0.6817E-05 | -0.7992E-08 | 0.8627E-03 | 19 | 10 |
| 1000 | 1 | 0.7000E+01 | 0.4585E-06 | -0.6184E-05 | 0.5571E-05 | 0.2666E-05 | -0.5319E-05 | 0.1188E-02 | 4 | 5 |
| 1000 | 2 | 0.7000E+01 | 0.1747E-06 | -0.1176E-04 | 0.1075E-04 | 0.3077E-05 | -0.9912E-05 | 0.2852E-02 | 17 | 12 |
| 1000 | 3 | 0.7000E+01 | 0.1137E-06 | -0.1639E-06 | 0.3310E-05 | 0.4794E-05 | -0.5329E-09 | 0.6433E-03 | 19 | 10 |
| 1050 | 1 | 0.7000E+01 | 0.3464E-06 | -0.4662E-05 | 0.4206E-05 | 0.1489E-05 | -0.4013E-05 | 0.9005E-03 | 4 | 2 |
| 1050 | 2 | 0.7000E+01 | 0.1322E-06 | -0.8864E-05 | 0.8134E-05 | 0.2634E-05 | -0.7467E-05 | 0.2189E-02 | 17 | 12 |
| 1050 | 3 | 0.7000E+01 | 0.8587E-07 | -0.1173E-06 | 0.2500E-05 | 0.4076E-05 | 0.6614E-08 | 0.4783E-03 | 19 | 10 |
| 1100 | 1 | 0.7000E+01 | 0.2617E-06 | -0.3519E-05 | 0.3186E-05 | 0.1959E-05 | -0.3025E-05 | 0.6774E-03 | 4 | 2 |
| 1100 | 2 | 0.7000E+01 | 0.9977E-07 | -0.6672E-05 | 0.6169E-05 | 0.1618E-05 | -0.5621E-05 | 0.1643E-02 | 17 | 12 |
| 1100 | 3 | 0.7000E+01 | 0.6624E-07 | -0.8016E-07 | 0.1905E-05 | 0.2927E-05 | 0.1424E-07 | 0.3689E-03 | 19 | 10 |
| 1150 | 1 | 0.7000E+01 | 0.1963E-06 | -0.2623E-05 | 0.2454E-05 | 0.1657E-05 | -0.2245E-05 | 0.3072E-03 | 4 | 2 |
| 1150 | 2 | 0.7000E+01 | 0.7509E-07 | -0.5014E-05 | 0.4689E-05 | 0.1481E-05 | -0.4215E-05 | 0.1249E-02 | 17 | 12 |
| 1150 | 3 | 0.7000E+01 | 0.5104E-07 | -0.5283E-07 | 0.1447E-05 | 0.2183E-05 | 0.1897E-07 | 0.2897E-03 | 19 | 10 |
| 1200 | 1 | 0.7000E+01 | 0.1485E-06 | -0.1981E-05 | 0.1838E-05 | 0.1908E-05 | -0.1712E-05 | 0.3799E-03 | 4 | 2 |
| 1200 | 2 | 0.7000E+01 | 0.5634E-07 | -0.3760E-05 | 0.3566E-05 | 0.1021E-05 | -0.3154E-05 | 0.9224E-03 | 17 | 12 |
| 1200 | 3 | 0.7000E+01 | 0.3834E-07 | -0.3503E-07 | 0.1108E-05 | 0.1324E-05 | 0.2191E-07 | 0.2189E-03 | 19 | 10 |
| 1250 | 1 | 0.7000E+01 | 0.1108E-06 | -0.1483E-05 | 0.1425E-05 | 0.9727E-06 | -0.1267E-05 | 0.2901E-03 | 5 | 2 |
| 1250 | 2 | 0.7000E+01 | 0.4261E-07 | -0.2814E-05 | 0.2716E-05 | 0.9038E-06 | -0.2361E-05 | 0.7036E-03 | 17 | 12 |
| 1250 | 3 | 0.7000E+01 | 0.2970E-07 | -0.2166E-07 | 0.8406E-06 | 0.1558E-05 | 0.2580E-07 | 0.1462E-03 | 19 | 10 |
| 1300 | 1 | 0.7000E+01 | 0.8350E-07 | -0.1094E-05 | 0.1099E-05 | 0.9062E-06 | -0.9260E-06 | 0.2295E-03 | 9 | 5 |
| 1300 | 2 | 0.7000E+01 | 0.3197E-07 | -0.2109E-05 | 0.2097E-05 | 0.4045E-06 | -0.1758E-05 | 0.5266E-03 | 17 | 12 |
| 1300 | 3 | 0.7000E+01 | 0.2266E-07 | -0.1052E-07 | 0.6442E-06 | 0.8756E-06 | 0.2498E-07 | 0.1303E-03 | 19 | 10 |
| 1350 | 1 | 0.7000E+01 | 0.6350E-07 | -0.8277E-06 | 0.8278E-06 | 0.1120E-05 | -0.7069E-06 | 0.1670E-03 | 9 | 5 |
| 1350 | 2 | 0.7000E+01 | 0.2405E-07 | -0.1561E-05 | 0.1615E-05 | 0.2549E-06 | -0.1292E-05 | 0.4115E-03 | 17 | 12 |
| 1350 | 3 | 0.7000E+01 | 0.1836E-07 | 0.1681E-08 | 0.4972E-06 | 0.7809E-06 | 0.2978E-07 | 0.8842E-04 | 19 | 10 |
| 1400 | 1 | 0.7000E+01 | 0.4732E-07 | -0.6131E-06 | 0.6508E-06 | 0.1841E-06 | -0.5228E-06 | 0.1324E-03 | 5 | 2 |
| 1400 | 2 | 0.7000E+01 | 0.1831E-07 | -0.1164E-05 | 0.1240E-05 | 0.4966E-06 | -0.9639E-06 | 0.3016E-03 | 17 | 12 |
| 1400 | 3 | 0.7000E+01 | 0.1538E-07 | 0.2510E-08 | 0.3873E-06 | 0.7524E-06 | 0.2726E-07 | 0.7567E-04 | 19 | 10 |
| 1450 | 1 | 0.7000E+01 | 0.3535E-07 | -0.4485E-06 | 0.5144E-06 | 0.2631E-06 | -0.3823E-06 | 0.9541E-04 | 9 | 5 |
| 1450 | 2 | 0.7000E+01 | 0.1377E-07 | -0.8526E-06 | 0.9616E-06 | 0.3557E-06 | -0.7122E-06 | 0.2282E-03 | 17 | 12 |
| 1450 | 3 | 0.7000E+01 | 0.1300E-07 | 0.8194E-08 | 0.3030E-06 | 0.6188E-06 | 0.3085E-07 | 0.6517E-04 | 19 | 10 |
| 1500 | 1 | 0.7000E+01 | 0.2737E-07 | -0.3477E-06 | 0.3868E-06 | 0.4935E-06 | -0.2987E-06 | 0.8432E-04 | 4 | 5 |
| 1500 | 2 | 0.7000E+01 | 0.1053E-07 | -0.6290E-06 | 0.7492E-06 | 0.1417E-06 | -0.5164E-06 | 0.1541E-03 | 17 | 12 |
| 1500 | 3 | 0.7000E+01 | 0.1101E-07 | 0.1151E-07 | 0.2539E-06 | 0.6455E-06 | 0.3122E-07 | 0.3967E-04 | 2 | 2 |
| 1550 | 1 | 0.7000E+01 | 0.2050E-07 | -0.2252E-06 | 0.3256E-06 | -0.7796E-06 | -0.1757E-06 | 0.5776E-04 | 6 | 5 |
| 1550 | 2 | 0.7000E+01 | 0.8323E-08 | -0.4573E-06 | 0.5907E-06 | -0.5889E-08 | -0.3735E-06 | 0.1073E-03 | 17 | 12 |
| 1550 | 3 | 0.7000E+01 | 0.9654E-08 | 0.1763E-07 | 0.1966E-06 | 0.4208E-06 | 0.3331E-07 | 0.3022E-04 | 2 | 6 |
| 1600 | 1 | 0.7000E+01 | 0.1667E-07 | -0.1641E-06 | 0.2639E-06 | -0.1137E-05 | -0.1350E-06 | 0.5204E-04 | 5 | 2 |
| 1600 | 2 | 0.7000E+01 | 0.6509E-08 | -0.3208E-06 | 0.5004E-06 | 0.2218E-06 | -0.2590E-06 | 0.9056E-04 | 17 | 12 |
| 1600 | 3 | 0.7000E+01 | 0.8893E-08 | 0.1007E-07 | 0.1397E-06 | 0.1220E-06 | 0.2590E-07 | 0.3290E-04 | 2 | 7 |
| 1650 | 1 | 0.7000E+01 | 0.1291E-07 | -0.1127E-06 | 0.2187E-06 | 0.2562E-06 | -0.8180E-07 | 0.4694E-04 | 8 | 3 |
| 1650 | 2 | 0.7000E+01 | 0.5420E-08 | -0.2171E-06 | 0.4095E-06 | 0.9220E-07 | -0.1538E-06 | 0.7069E-04 | 17 | 12 |
| 1650 | 3 | 0.7000E+01 | 0.8137E-08 | 0.2109E-07 | 0.1294E-06 | 0.3859E-06 | 0.3216E-07 | 0.2580E-04 | 19 | 10 |
| 1700 | 1 | 0.7000E+01 | 0.1152E-07 | -0.7582E-07 | 0.1765E-06 | 0.1902E-05 | -0.5531E-07 | 0.4492E-04 | 4 | 5 |
| 1700 | 2 | 0.7000E+01 | 0.4759E-08 | -0.1353E-06 | 0.3323E-06 | 0.3140E-06 | -0.9820E-07 | 0.4505E-04 | 17 | 12 |
| 1700 | 3 | 0.7000E+01 | 0.7917E-08 | 0.1300E-07 | 0.9765E-07 | 0.1903E-06 | 0.2685E-07 | 0.2531E-04 | 2 | 6 |

Listing E-12. Continued

| | | | | | | | | | | |
|------|---|------------|------------|-------------|------------|-------------|-------------|------------|----|----|
| 1750 | 1 | 0.7000E+01 | 0.7408E-08 | -0.4404E-07 | 0.1547E-06 | 0.1009E-05 | -0.2273E-07 | 0.1930E-04 | 5 | 3 |
| 1750 | 2 | 0.7000E+01 | 0.3835E-08 | -0.9553E-07 | 0.2878E-06 | 0.3027E-06 | -0.5338E-07 | 0.3397E-04 | 18 | 12 |
| 1750 | 3 | 0.7000E+01 | 0.7549E-08 | 0.2247E-07 | 0.9811E-07 | 0.3257E-06 | 0.2935E-07 | 0.2160E-04 | 18 | 2 |
| 1800 | 1 | 0.7000E+01 | 0.9230E-08 | -0.1741E-07 | 0.1273E-06 | 0.4991E-06 | -0.8290E-09 | 0.3009E-04 | 6 | 4 |
| 1800 | 2 | 0.7000E+01 | 0.4190E-08 | -0.3089E-07 | 0.2523E-06 | 0.2400E-06 | 0.9555E-09 | 0.3765E-04 | 18 | 10 |
| 1800 | 3 | 0.7000E+01 | 0.7582E-08 | 0.2291E-07 | 0.8296E-07 | 0.6315E-07 | 0.3206E-07 | 0.2852E-04 | 2 | 6 |
| 1850 | 1 | 0.7000E+01 | 0.8158E-08 | -0.4953E-08 | 0.1108E-06 | 0.7757E-06 | 0.2973E-08 | 0.2152E-04 | 3 | 5 |
| 1850 | 2 | 0.7000E+01 | 0.3985E-08 | 0.7052E-09 | 0.2179E-06 | -0.2150E-07 | 0.2382E-07 | 0.4146E-04 | 17 | 12 |
| 1850 | 3 | 0.7000E+01 | 0.7222E-08 | 0.2392E-07 | 0.7800E-07 | 0.1517E-06 | 0.3439E-07 | 0.2448E-04 | 10 | 3 |
| 1900 | 1 | 0.7000E+01 | 0.8389E-08 | 0.1186E-07 | 0.1042E-06 | -0.2070E-06 | 0.1495E-07 | 0.3062E-04 | 7 | 5 |
| 1900 | 2 | 0.7000E+01 | 0.3981E-08 | 0.2535E-07 | 0.1977E-06 | 0.4593E-06 | 0.3859E-07 | 0.4141E-04 | 13 | 2 |
| 1900 | 3 | 0.7000E+01 | 0.7250E-08 | 0.2254E-07 | 0.7217E-07 | 0.6173E-07 | 0.3194E-07 | 0.2168E-04 | 7 | 10 |
| 1950 | 1 | 0.7000E+01 | 0.8173E-08 | 0.1364E-07 | 0.1042E-06 | -0.1578E-05 | 0.2269E-07 | 0.3452E-04 | 7 | 5 |
| 1950 | 2 | 0.7000E+01 | 0.3909E-08 | 0.3693E-07 | 0.1852E-06 | -0.1461E-06 | 0.4962E-07 | 0.3670E-04 | 5 | 10 |
| 1950 | 3 | 0.7000E+01 | 0.7072E-08 | 0.2227E-07 | 0.6044E-07 | 0.6566E-07 | 0.3261E-07 | 0.2465E-04 | 10 | 7 |
| 2000 | 1 | 0.7000E+01 | 0.7555E-08 | 0.2888E-07 | 0.9774E-07 | 0.3596E-06 | 0.3525E-07 | 0.2486E-04 | 9 | 4 |
| 2000 | 2 | 0.7000E+01 | 0.3769E-08 | 0.5191E-07 | 0.1674E-06 | -0.2109E-08 | 0.6092E-07 | 0.2895E-04 | 4 | 3 |
| 2000 | 3 | 0.7000E+01 | 0.6604E-08 | 0.2210E-07 | 0.5535E-07 | 0.2403E-07 | 0.2961E-07 | 0.2104E-04 | 2 | 10 |
| 2050 | 1 | 0.7000E+01 | 0.8273E-08 | 0.2937E-07 | 0.8228E-07 | 0.1770E-06 | 0.2775E-07 | 0.2797E-04 | 4 | 4 |
| 2050 | 2 | 0.7000E+01 | 0.3803E-08 | 0.5718E-07 | 0.1588E-06 | -0.1876E-07 | 0.6199E-07 | 0.3326E-04 | 20 | 9 |
| 2050 | 3 | 0.7000E+01 | 0.7058E-08 | 0.2123E-07 | 0.4688E-07 | 0.3627E-07 | 0.2653E-07 | 0.2091E-04 | 10 | 10 |
| 2100 | 1 | 0.7000E+01 | 0.6310E-08 | 0.2817E-07 | 0.8547E-07 | 0.7301E-06 | 0.3388E-07 | 0.1895E-04 | 4 | 4 |
| 2100 | 2 | 0.7000E+01 | 0.3572E-08 | 0.7785E-07 | 0.1789E-06 | 0.4253E-06 | 0.8924E-07 | 0.2997E-04 | 10 | 10 |
| 2100 | 3 | 0.7000E+01 | 0.7537E-08 | 0.2385E-07 | 0.6729E-07 | 0.8361E-07 | 0.3225E-07 | 0.2495E-04 | 2 | 10 |
| 2150 | 1 | 0.7000E+01 | 0.7749E-08 | 0.3497E-07 | 0.8394E-07 | -0.2776E-06 | 0.3769E-07 | 0.2521E-04 | 7 | 4 |
| 2150 | 2 | 0.7000E+01 | 0.3608E-08 | 0.7491E-07 | 0.1673E-06 | -0.2770E-06 | 0.8427E-07 | 0.3127E-04 | 8 | 4 |
| 2150 | 3 | 0.7000E+01 | 0.6617E-08 | 0.2110E-07 | 0.4111E-07 | -0.1193E-06 | 0.2649E-07 | 0.1969E-04 | 4 | 6 |
| 2200 | 1 | 0.7000E+01 | 0.6721E-08 | 0.3018E-07 | 0.9419E-07 | -0.5036E-06 | 0.3591E-07 | 0.1962E-04 | 9 | 5 |
| 2200 | 2 | 0.7000E+01 | 0.3361E-08 | 0.5963E-07 | 0.1468E-06 | -0.9926E-07 | 0.6292E-07 | 0.2936E-04 | 14 | 3 |
| 2200 | 3 | 0.7000E+01 | 0.6684E-08 | 0.2559E-07 | 0.5471E-07 | 0.9231E-07 | 0.2909E-07 | 0.1955E-04 | 18 | 10 |
| 2250 | 1 | 0.7000E+01 | 0.7026E-08 | 0.3721E-07 | 0.9468E-07 | -0.1987E-06 | 0.4237E-07 | 0.2136E-04 | 3 | 4 |
| 2250 | 2 | 0.7000E+01 | 0.3819E-08 | 0.8006E-07 | 0.1649E-06 | 0.2623E-06 | 0.9357E-07 | 0.3806E-04 | 14 | 2 |
| 2250 | 3 | 0.7000E+01 | 0.6889E-08 | 0.2262E-07 | 0.3947E-07 | 0.3671E-07 | 0.2478E-07 | 0.2170E-04 | 4 | 8 |
| 2300 | 1 | 0.7000E+01 | 0.7309E-08 | 0.3418E-07 | 0.7934E-07 | 0.3687E-06 | 0.4031E-07 | 0.2348E-04 | 11 | 3 |
| 2300 | 2 | 0.7000E+01 | 0.3485E-08 | 0.7649E-07 | 0.1552E-06 | 0.1619E-06 | 0.9026E-07 | 0.3050E-04 | 16 | 12 |
| 2300 | 3 | 0.7000E+01 | 0.7294E-08 | 0.2921E-07 | 0.5609E-07 | 0.3300E-07 | 0.3290E-07 | 0.2471E-04 | 15 | 6 |
| 2350 | 1 | 0.7000E+01 | 0.7000E-08 | 0.3288E-07 | 0.9196E-07 | 0.1800E-07 | 0.4047E-07 | 0.2318E-04 | 3 | 3 |
| 2350 | 2 | 0.7000E+01 | 0.3458E-08 | 0.7342E-07 | 0.1511E-06 | 0.2333E-06 | 0.8421E-07 | 0.3167E-04 | 17 | 9 |
| 2350 | 3 | 0.7000E+01 | 0.7489E-08 | 0.2991E-07 | 0.5273E-07 | -0.6849E-07 | 0.3345E-07 | 0.2355E-04 | 12 | 4 |
| 2400 | 1 | 0.7000E+01 | 0.7181E-08 | 0.3668E-07 | 0.8968E-07 | -0.5559E-06 | 0.4622E-07 | 0.2346E-04 | 3 | 3 |
| 2400 | 2 | 0.7000E+01 | 0.3376E-08 | 0.7487E-07 | 0.1526E-06 | 0.1893E-07 | 0.8603E-07 | 0.2666E-04 | 4 | 11 |
| 2400 | 3 | 0.7000E+01 | 0.7389E-08 | 0.2600E-07 | 0.3452E-07 | -0.5617E-07 | 0.2799E-07 | 0.2580E-04 | 16 | 3 |
| 2450 | 1 | 0.7000E+01 | 0.7509E-08 | 0.4592E-07 | 0.8406E-07 | 0.1070E-06 | 0.5677E-07 | 0.2144E-04 | 9 | 2 |
| 2450 | 2 | 0.7000E+01 | 0.3524E-08 | 0.9181E-07 | 0.1626E-06 | -0.2331E-07 | 0.1084E-06 | 0.2944E-04 | 13 | 4 |
| 2450 | 3 | 0.7000E+01 | 0.7984E-08 | 0.3032E-07 | 0.5761E-07 | 0.1495E-07 | 0.3525E-07 | 0.2334E-04 | 15 | 5 |
| 2500 | 1 | 0.7000E+01 | 0.7082E-08 | 0.3843E-07 | 0.6919E-07 | 0.6969E-06 | 0.4394E-07 | 0.2361E-04 | 11 | 2 |
| 2500 | 2 | 0.7000E+01 | 0.3356E-08 | 0.8245E-07 | 0.1530E-06 | 0.1383E-06 | 0.9711E-07 | 0.2780E-04 | 6 | 11 |
| 2500 | 3 | 0.7000E+01 | 0.7325E-08 | 0.2820E-07 | 0.5760E-07 | 0.1871E-06 | 0.3153E-07 | 0.2360E-04 | 11 | 6 |

Listing E-12. Continued

| BLOCK 1 VARIABLES AT K = 2 | | | | ITERATION NUMBER: | | 2500 | | | |
|----------------------------|------------|-------------|-------------|-------------------|------------|------------|------------|------------|--|
| J | PRESSURE | TEMPERATURE | MACH NUMBER | TOTAL PRESS | U-COSINE | V-COSINE | X | Y | |
| 2 | 0.9912E+01 | 0.5330E+03 | 0.7926E+00 | 0.1500E+02 | 0.1000E+01 | 0.3425E-05 | 0.2500E+00 | 0.1000E+00 | |
| 4 | 0.9914E+01 | 0.5331E+03 | 0.7924E+00 | 0.1500E+02 | 0.1000E+01 | 0.3502E-04 | 0.7500E+00 | 0.1000E+00 | |
| 6 | 0.9934E+01 | 0.5334E+03 | 0.7905E+00 | 0.1500E+02 | 0.1000E+01 | 0.4344E-03 | 0.1250E+01 | 0.1000E+00 | |
| 8 | 0.1010E+02 | 0.5359E+03 | 0.7737E+00 | 0.1501E+02 | 0.1000E+01 | 0.3836E-02 | 0.1750E+01 | 0.1000E+00 | |
| 10 | 0.1084E+02 | 0.5470E+03 | 0.6951E+00 | 0.1497E+02 | 0.9999E+00 | 0.1655E-01 | 0.2250E+01 | 0.1062E+00 | |
| 12 | 0.1192E+02 | 0.5620E+03 | 0.5820E+00 | 0.1499E+02 | 0.9997E+00 | 0.2346E-01 | 0.2750E+01 | 0.1187E+00 | |
| 14 | 0.1261E+02 | 0.5711E+03 | 0.5035E+00 | 0.1499E+02 | 0.9997E+00 | 0.2507E-01 | 0.3250E+01 | 0.1312E+00 | |
| | | | | | | | | | |
| BLOCK 1 VARIABLES AT K = 4 | | | | ITERATION NUMBER: | | 2500 | | | |
| J | PRESSURE | TEMPERATURE | MACH NUMBER | TOTAL PRESS | U-COSINE | V-COSINE | X | Y | |
| 2 | 0.9912E+01 | 0.5330E+03 | 0.7926E+00 | 0.1500E+02 | 0.1000E+01 | 0.4923E-05 | 0.2500E+00 | 0.3000E+00 | |
| 4 | 0.9913E+01 | 0.5330E+03 | 0.7925E+00 | 0.1500E+02 | 0.1000E+01 | 0.9099E-04 | 0.7500E+00 | 0.3000E+00 | |
| 6 | 0.9926E+01 | 0.5332E+03 | 0.7913E+00 | 0.1500E+02 | 0.1000E+01 | 0.1173E-02 | 0.1250E+01 | 0.3000E+00 | |
| 8 | 0.1005E+02 | 0.5351E+03 | 0.7796E+00 | 0.1501E+02 | 0.9999E+00 | 0.1104E-01 | 0.1750E+01 | 0.3000E+00 | |
| 10 | 0.1079E+02 | 0.5462E+03 | 0.6999E+00 | 0.1496E+02 | 0.9986E+00 | 0.5311E-01 | 0.2250E+01 | 0.3187E+00 | |
| 12 | 0.1192E+02 | 0.5621E+03 | 0.5811E+00 | 0.1499E+02 | 0.9975E+00 | 0.7023E-01 | 0.2750E+01 | 0.3562E+00 | |
| 14 | 0.1262E+02 | 0.5713E+03 | 0.5017E+00 | 0.1498E+02 | 0.9973E+00 | 0.7409E-01 | 0.3250E+01 | 0.3937E+00 | |
| | | | | | | | | | |
| BLOCK 2 VARIABLES AT K = 3 | | | | ITERATION NUMBER: | | 2500 | | | |
| J | PRESSURE | TEMPERATURE | MACH NUMBER | TOTAL PRESS | U-COSINE | V-COSINE | X | Y | |
| 3 | 0.9912E+01 | 0.5330E+03 | 0.7926E+00 | 0.1500E+02 | 0.1000E+01 | 0.4292E-05 | 0.2500E+00 | 0.5000E+00 | |
| 7 | 0.9912E+01 | 0.5330E+03 | 0.7926E+00 | 0.1500E+02 | 0.1000E+01 | 0.1038E-03 | 0.7500E+00 | 0.5000E+00 | |
| 11 | 0.9911E+01 | 0.5330E+03 | 0.7924E+00 | 0.1500E+02 | 0.1000E+01 | 0.1402E-02 | 0.1250E+01 | 0.5000E+00 | |
| 15 | 0.9938E+01 | 0.5334E+03 | 0.7894E+00 | 0.1499E+02 | 0.9999E+00 | 0.1605E-01 | 0.1750E+01 | 0.5000E+00 | |
| 19 | 0.1068E+02 | 0.5445E+03 | 0.7152E+00 | 0.1501E+02 | 0.9957E+00 | 0.9317E-01 | 0.2250E+01 | 0.5312E+00 | |
| 23 | 0.1193E+02 | 0.5621E+03 | 0.5811E+00 | 0.1500E+02 | 0.9929E+00 | 0.1187E+00 | 0.2750E+01 | 0.5937E+00 | |
| 27 | 0.1264E+02 | 0.5714E+03 | 0.5003E+00 | 0.1500E+02 | 0.9924E+00 | 0.1230E+00 | 0.3250E+01 | 0.6562E+00 | |
| | | | | | | | | | |
| BLOCK 2 VARIABLES AT K = 7 | | | | ITERATION NUMBER: | | 2500 | | | |
| J | PRESSURE | TEMPERATURE | MACH NUMBER | TOTAL PRESS | U-COSINE | V-COSINE | X | Y | |
| 3 | 0.9912E+01 | 0.5330E+03 | 0.7926E+00 | 0.1500E+02 | 0.1000E+01 | 0.4890E-05 | 0.2500E+00 | 0.7000E+00 | |
| 7 | 0.9911E+01 | 0.5330E+03 | 0.7927E+00 | 0.1500E+02 | 0.1000E+01 | 0.8750E-04 | 0.7500E+00 | 0.7000E+00 | |
| 11 | 0.9899E+01 | 0.5328E+03 | 0.7937E+00 | 0.1500E+02 | 0.1000E+01 | 0.1189E-02 | 0.1250E+01 | 0.7000E+00 | |
| 15 | 0.9978E+01 | 0.5310E+03 | 0.8057E+00 | 0.1500E+02 | 0.9999E+00 | 0.1680E-01 | 0.1750E+01 | 0.7000E+00 | |
| 19 | 0.1053E+02 | 0.5425E+03 | 0.7282E+00 | 0.1499E+02 | 0.9894E+00 | 0.1454E+00 | 0.2250E+01 | 0.7437E+00 | |
| 23 | 0.1197E+02 | 0.5626E+03 | 0.5764E+00 | 0.1499E+02 | 0.9857E+00 | 0.1685E+00 | 0.2750E+01 | 0.8312E+00 | |
| 27 | 0.1268E+02 | 0.5720E+03 | 0.4950E+00 | 0.1499E+02 | 0.9852E+00 | 0.1717E+00 | 0.3250E+01 | 0.9187E+00 | |
| | | | | | | | | | |
| BLOCK 3 VARIABLES AT K = 2 | | | | ITERATION NUMBER: | | 2500 | | | |
| J | PRESSURE | TEMPERATURE | MACH NUMBER | TOTAL PRESS | U-COSINE | V-COSINE | X | Y | |
| 1 | 0.1261E+02 | 0.5711E+03 | 0.5035E+00 | 0.1499E+02 | 0.9997E+00 | 0.2507E-01 | 0.3250E+01 | 0.1312E+00 | |
| 3 | 0.1308E+02 | 0.5772E+03 | 0.4453E+00 | 0.1499E+02 | 0.9997E+00 | 0.2569E-01 | 0.3750E+01 | 0.1437E+00 | |
| 5 | 0.1342E+02 | 0.5814E+03 | 0.4012E+00 | 0.1499E+02 | 0.9997E+00 | 0.2557E-01 | 0.4250E+01 | 0.1562E+00 | |
| 7 | 0.1366E+02 | 0.5844E+03 | 0.3666E+00 | 0.1499E+02 | 0.9997E+00 | 0.2472E-01 | 0.4750E+01 | 0.1687E+00 | |
| 9 | 0.1384E+02 | 0.5865E+03 | 0.3395E+00 | 0.1499E+02 | 0.9997E+00 | 0.2275E-01 | 0.5250E+01 | 0.1812E+00 | |
| 11 | 0.1397E+02 | 0.5881E+03 | 0.3195E+00 | 0.1499E+02 | 0.9998E+00 | 0.1916E-01 | 0.5750E+01 | 0.1937E+00 | |
| 13 | 0.1405E+02 | 0.5890E+03 | 0.3060E+00 | 0.1499E+02 | 0.9999E+00 | 0.1319E-01 | 0.6250E+01 | 0.2000E+00 | |
| 15 | 0.1409E+02 | 0.5895E+03 | 0.2985E+00 | 0.1499E+02 | 0.1000E+01 | 0.7755E-02 | 0.6750E+01 | 0.2000E+00 | |
| 17 | 0.1411E+02 | 0.5898E+03 | 0.2946E+00 | 0.1499E+02 | 0.1000E+01 | 0.4063E-02 | 0.7250E+01 | 0.2000E+00 | |
| 19 | 0.1412E+02 | 0.5898E+03 | 0.2925E+00 | 0.1498E+02 | 0.1000E+01 | 0.1954E-02 | 0.7750E+01 | 0.2000E+00 | |

Listing E-12. Concluded

| BLOCK 3 VARIABLES AT K = 4 | | | | ITERATION NUMBER: | | 2500 | | | |
|-----------------------------|------------|-------------|-------------|-------------------|------------|------------|------------|------------|--|
| J | PRESSURE | TEMPERATURE | MACH NUMBER | TOTAL PRESS | U-COSINE | V-COSINE | X | Y | |
| 1 | 0.1262E+02 | 0.5713E+03 | 0.5017E+00 | 0.1498E+02 | 0.9973E+00 | 0.7409E-01 | 0.3250E+01 | 0.3937E+00 | |
| 3 | 0.1310E+02 | 0.5774E+03 | 0.4438E+00 | 0.1499E+02 | 0.9972E+00 | 0.7523E-01 | 0.3750E+01 | 0.4312E+00 | |
| 5 | 0.1343E+02 | 0.5815E+03 | 0.3999E+00 | 0.1499E+02 | 0.9972E+00 | 0.7466E-01 | 0.4250E+01 | 0.4687E+00 | |
| 7 | 0.1367E+02 | 0.5845E+03 | 0.3652E+00 | 0.1499E+02 | 0.9974E+00 | 0.7213E-01 | 0.4750E+01 | 0.5062E+00 | |
| 9 | 0.1386E+02 | 0.5867E+03 | 0.3379E+00 | 0.1499E+02 | 0.9978E+00 | 0.6620E-01 | 0.5250E+01 | 0.5437E+00 | |
| 11 | 0.1399E+02 | 0.5883E+03 | 0.3174E+00 | 0.1500E+02 | 0.9985E+00 | 0.5484E-01 | 0.5750E+01 | 0.5812E+00 | |
| 13 | 0.1407E+02 | 0.5892E+03 | 0.3041E+00 | 0.1500E+02 | 0.9994E+00 | 0.3544E-01 | 0.6250E+01 | 0.6000E+00 | |
| 15 | 0.1410E+02 | 0.5897E+03 | 0.2978E+00 | 0.1500E+02 | 0.9998E+00 | 0.1962E-01 | 0.6750E+01 | 0.6000E+00 | |
| 17 | 0.1412E+02 | 0.5898E+03 | 0.2949E+00 | 0.1500E+02 | 0.1000E+01 | 0.9887E-02 | 0.7250E+01 | 0.6000E+00 | |
| 19 | 0.1412E+02 | 0.5899E+03 | 0.2935E+00 | 0.1499E+02 | 0.1000E+01 | 0.4715E-02 | 0.7750E+01 | 0.6000E+00 | |
| BLOCK 3 VARIABLES AT K = 6 | | | | ITERATION NUMBER: | | 2500 | | | |
| J | PRESSURE | TEMPERATURE | MACH NUMBER | TOTAL PRESS | U-COSINE | V-COSINE | X | Y | |
| 1 | 0.1264E+02 | 0.5714E+03 | 0.5003E+00 | 0.1500E+02 | 0.9924E+00 | 0.1230E+00 | 0.3250E+01 | 0.6562E+00 | |
| 3 | 0.1312E+02 | 0.5776E+03 | 0.4423E+00 | 0.1501E+02 | 0.9922E+00 | 0.1245E+00 | 0.3750E+01 | 0.7187E+00 | |
| 5 | 0.1345E+02 | 0.5817E+03 | 0.3983E+00 | 0.1501E+02 | 0.9923E+00 | 0.1235E+00 | 0.4250E+01 | 0.7812E+00 | |
| 7 | 0.1370E+02 | 0.5847E+03 | 0.3632E+00 | 0.1501E+02 | 0.9928E+00 | 0.1198E+00 | 0.4750E+01 | 0.8437E+00 | |
| 9 | 0.1389E+02 | 0.5870E+03 | 0.3347E+00 | 0.1501E+02 | 0.9938E+00 | 0.1110E+00 | 0.5250E+01 | 0.9062E+00 | |
| 11 | 0.1403E+02 | 0.5887E+03 | 0.3123E+00 | 0.1501E+02 | 0.9957E+00 | 0.9218E-01 | 0.5750E+01 | 0.9687E+00 | |
| 13 | 0.1411E+02 | 0.5897E+03 | 0.2989E+00 | 0.1502E+02 | 0.9985E+00 | 0.5479E-01 | 0.6250E+01 | 0.1000E+01 | |
| 15 | 0.1413E+02 | 0.5899E+03 | 0.2952E+00 | 0.1501E+02 | 0.9996E+00 | 0.2751E-01 | 0.6750E+01 | 0.1000E+01 | |
| 17 | 0.1413E+02 | 0.5899E+03 | 0.2942E+00 | 0.1501E+02 | 0.9999E+00 | 0.1281E-01 | 0.7250E+01 | 0.1000E+01 | |
| 19 | 0.1413E+02 | 0.5899E+03 | 0.2938E+00 | 0.1500E+02 | 0.1000E+01 | 0.5888E-02 | 0.7750E+01 | 0.1000E+01 | |
| BLOCK 3 VARIABLES AT K = 8 | | | | ITERATION NUMBER: | | 2500 | | | |
| J | PRESSURE | TEMPERATURE | MACH NUMBER | TOTAL PRESS | U-COSINE | V-COSINE | X | Y | |
| 1 | 0.1268E+02 | 0.5720E+03 | 0.4950E+00 | 0.1499E+02 | 0.9852E+00 | 0.1717E+00 | 0.3250E+01 | 0.9187E+00 | |
| 3 | 0.1315E+02 | 0.5780E+03 | 0.4376E+00 | 0.1500E+02 | 0.9849E+00 | 0.1731E+00 | 0.3750E+01 | 0.1006E+01 | |
| 5 | 0.1348E+02 | 0.5822E+03 | 0.3933E+00 | 0.1500E+02 | 0.9850E+00 | 0.1724E+00 | 0.4250E+01 | 0.1094E+01 | |
| 7 | 0.1373E+02 | 0.5852E+03 | 0.3571E+00 | 0.1500E+02 | 0.9856E+00 | 0.1689E+00 | 0.4750E+01 | 0.1181E+01 | |
| 9 | 0.1393E+02 | 0.5876E+03 | 0.3262E+00 | 0.1499E+02 | 0.9871E+00 | 0.1598E+00 | 0.5250E+01 | 0.1269E+01 | |
| 11 | 0.1409E+02 | 0.5896E+03 | 0.2994E+00 | 0.1500E+02 | 0.9907E+00 | 0.1362E+00 | 0.5750E+01 | 0.1356E+01 | |
| 13 | 0.1419E+02 | 0.5907E+03 | 0.2852E+00 | 0.1501E+02 | 0.9977E+00 | 0.6838E-01 | 0.6250E+01 | 0.1400E+01 | |
| 15 | 0.1417E+02 | 0.5905E+03 | 0.2867E+00 | 0.1500E+02 | 0.9996E+00 | 0.2928E-01 | 0.6750E+01 | 0.1400E+01 | |
| 17 | 0.1415E+02 | 0.5902E+03 | 0.2890E+00 | 0.1499E+02 | 0.9999E+00 | 0.1208E-01 | 0.7250E+01 | 0.1400E+01 | |
| 19 | 0.1414E+02 | 0.5902E+03 | 0.2907E+00 | 0.1499E+02 | 0.1000E+01 | 0.4999E-02 | 0.7750E+01 | 0.1400E+01 | |
| BLOCK 3 VARIABLES AT K = 10 | | | | ITERATION NUMBER: | | 2500 | | | |
| J | PRESSURE | TEMPERATURE | MACH NUMBER | TOTAL PRESS | U-COSINE | V-COSINE | X | Y | |
| 1 | 0.1273E+02 | 0.5733E+03 | 0.4818E+00 | 0.1493E+02 | 0.9759E+00 | 0.2184E+00 | 0.3250E+01 | 0.1181E+01 | |
| 3 | 0.1320E+02 | 0.5791E+03 | 0.4261E+00 | 0.1496E+02 | 0.9747E+00 | 0.2236E+00 | 0.3750E+01 | 0.1294E+01 | |
| 5 | 0.1353E+02 | 0.5831E+03 | 0.3833E+00 | 0.1497E+02 | 0.9749E+00 | 0.2227E+00 | 0.4250E+01 | 0.1406E+01 | |
| 7 | 0.1377E+02 | 0.5860E+03 | 0.3478E+00 | 0.1497E+02 | 0.9755E+00 | 0.2202E+00 | 0.4750E+01 | 0.1519E+01 | |
| 9 | 0.1398E+02 | 0.5885E+03 | 0.3153E+00 | 0.1497E+02 | 0.9767E+00 | 0.2147E+00 | 0.5250E+01 | 0.1631E+01 | |
| 11 | 0.1418E+02 | 0.5909E+03 | 0.2795E+00 | 0.1497E+02 | 0.9795E+00 | 0.2013E+00 | 0.5750E+01 | 0.1744E+01 | |
| 13 | 0.1432E+02 | 0.5926E+03 | 0.2669E+00 | 0.1504E+02 | 0.9980E+00 | 0.6243E-01 | 0.6250E+01 | 0.1800E+01 | |
| 15 | 0.1420E+02 | 0.5912E+03 | 0.2823E+00 | 0.1501E+02 | 0.9999E+00 | 0.1254E-01 | 0.6750E+01 | 0.1800E+01 | |
| 17 | 0.1416E+02 | 0.5906E+03 | 0.2881E+00 | 0.1500E+02 | 0.1000E+01 | 0.2230E-02 | 0.7250E+01 | 0.1800E+01 | |
| 19 | 0.1414E+02 | 0.5905E+03 | 0.2905E+00 | 0.1500E+02 | 0.1000E+01 | 0.7153E-03 | 0.7750E+01 | 0.1800E+01 | |

NOMENCLATURE

| | |
|---------|---|
| A_j | Flux Jacobian formed from the derivatives of F_j with respect to Q |
| a | Speed of sound; for a perfect gas $a^2 = T$ |
| E | Total energy per unit volume; $E = \rho(e + 1/2u_ju_j)$ |
| e | Internal energy per unit mass; for a perfect gas $e = T/(\gamma - 1)\gamma$ |
| F_j | Inviscid flux vector |
| G_j | Viscous flux vector |
| I | Identify matrix of rank 4 or 5 for 2-D or 3-D, respectively |
| J | Jacobian of the coordinate transformation from X_j to ξ_j |
| K | Coefficient of thermal conductivity |
| K_j^i | Metric element; the derivative of ξ_i with respect to X_j |
| P | Pressure; for a perfect gas, $P = (\gamma - 1)(E - 1/2\rho u_ju_j)$ |
| Pr | Prandtl number: $Pr = \mu C_p/K$ |
| Q | Conservation vector |
| q_j | Heat flux vector |
| Re | Reynolds number: $Re = \rho a X_r/\mu$ |
| RHS | Right-hand-side vector; finite difference form of the steady Navier-Stokes equation multiplied by $-\Delta t$ |
| T | Temperature; for a perfect, gas $T = \gamma P/\rho$ |
| t | Time variable |
| U_j | Contravariant velocity components, (U, V, W) |

| | |
|---------------|---|
| u_j | Physical velocity components (u, v, w) |
| X_j | Spatial coordinates (X, Y, Z) |
| γ | Ratio of specific heats |
| δ_{ij} | Kronecker delta |
| λ | Second coefficient of viscosity |
| τ_{ij} | Viscous stress tensor |
| ϕ^2 | Kinetic energy factor: $1/2(\gamma - 1)u_j u_j$ |

Subscripts

| | |
|--------------------|---|
| x, y, z | Differentiation with respect to subscript |
| ξ, η, ζ | |

Superscript .

| | |
|-----|------------|
| n | Time level |
|-----|------------|