

Passive Landing Gear using Coupled Mechanical Design

Samuel Baker, Dean Soccol, Adam Postula and Mandyam V. Srinivasan

University of Queensland, Brisbane, Australia

Abstract

The ability of UAV's (Unmanned Aerial Vehicles) to land on unknown and uneven terrain is an important area of research, particularly for applications such as field surveillance. This paper presents a novel solution to this problem using mechanical design, with a legged landing gear design that provides both suspension and stability on uneven terrain. The key features of this design are differential loading across legs as well as a conditional locking mechanism that resists post-landing disturbances. Results from a prototype design show robust stability when landing on uneven surfaces inclined up to 20 degrees, with analysis of an optimally damped suspension profile (for an approximated mass spring damper system with constant damping).

1 Introduction

The use of small scale UAVs (Unmanned Aerial Vehicles) is becoming increasingly common in applications such as aerial photography, building inspections, military applications, surveillance and personal entertainment. One requirement that is common to all these areas is the ability of the aircraft to land safely, and in some cases the ability to land or "perch" on uneven and/or unknown terrain.

Typically the solution to landing on rough terrain has been to alter the terrain to suit the aircraft, such as creating landing strips or making level clearings in the case of helicopters and other VTOL (vertical takeoff and landing) aircraft. While other solutions such as modified landing gear were suggested in the 1960s, these ideas were never fully developed. However given the recent interest in using small scale UAVs for surveillance purposes, landing on uneven terrain has again become an important area of research. An example would be a multirotor aircraft, such as that shown in Figure 1, with a maximum dimension of less than a meter.



Figure 1 - Multi-Rotor Test Platform

The trend within the field of UAVs is towards progressively smaller aircraft, meaning that active control systems or landing gears that were previously suitable, have become problematic post-miniaturization. This is where intelligent mechanical design shows increasing promise, with the potential to have control inherent within the mechanical design of the landing gear.

With the increase in computing power, there has been a trend within the field of UAVs to solve all problems using a combination of sensing and control. While mapping of the ground and active control of the landing gear is possible, it does beg the question, is there a simpler solution? Observation of systems in nature suggests that there are shortcuts that might be applied to reduce the complexity of the system. An example is that even within the human body, not all control is covered by the central nervous system. Indeed, there is control at the level of the spinal cord, and even in the mechanics of the joints themselves. Muscles in the legs cover multiple joints and are therefore able to balance forces, absorb shock and recover energy via the tendons and ligaments. All of these functions are inherent to the design of the leg.

Such design principles are therefore applied to the aircraft's landing gear.

2 Background

Current research in the area of landing gear for aircraft can be categorized into three broad areas, traditional landing gear as seen on most commercial aircraft, actively controlled landing gear, and passively controlled landing gear. This paper will focus on the third approach.

Examples of existing research within this field include the avian-inspired perching landing gear by Doyle et al. [2013] which through clever mechanical design uses the weight of the aircraft to passively grip on to a perch, or simple but effective designs by [Mellinger et al., 2010] that use spines for landing on horizontal surfaces. Further more work by [Bayraktar and Feron, 2008] investigated the feasibility of automated small scale helicopter landings on attitudes up to sixty degrees. While this particular study used an adhesive board for the landing site, it none the less showed that automated approach maneuvers are not the limiting factor when it comes to unorthodox landings.

Other approaches have included landing on vertical surfaces such as the light aircraft by [Desbiens and Cutkosky, 2010; Desbiens et al., 2011] designed to hang off a vertical wall by using a combination of spines/hooks and a specialized stall maneuver. While this method does require a suitable surface texture, the stalled approach is beneficial in that it allows a gentle landing.

Another more direct approach by [Kovac et al., 2010] aims at the wall and uses the impact to deploy a

pair of vertically opposed barbs into the contact surface with a small electric motor capable of releasing the UAV. Yet other variations include the sticky-pad plane by [Anderson et al., 2009] able to land and adhere to a vertical surface by using a two sticky-pads. Release and subsequent landings are possible thanks to a stacked puck design which allows a fresh pair of pads to be utilized and then dispensed for each landing/take-off sequence.

Passive mechanisms have also been investigated for use in applications such as in space, such as the self-leveling landing gear [Rippere and Wiens, 2010] and the rocker-bogie model currently used for the mars rovers. Similarly grasping tasks in unknown environments can also benefit from using passive mechanisms in order to improve outcomes [Dollar et al., 2005]. While most of these passive designs are relatively new, there were in fact several patents back in the 1960's that detailed unorthodox designs for landing aircraft on rough terrain using similar principles [Maltby, 1960; Perdue, 1954; Stancliffe, 1977].

While many of these older designs were either impractical or never built, the concepts were nevertheless on the right track. Fifty years later as aircraft as are now being miniaturized, passive designs are again being investigated, such as the passive torque-balanced wing-control device by [Sreetharan and Wood, 2012]. It is in this light that this study provides an improved solution to the problem of landing on uneven terrain, accommodating a greater range of landing sites while still being miniaturization compatible.

3 Theoretical Design

The landing gear has been designed using the principle of a mechanical differential, that is, a shared loading between two components that are usually mechanically isolated. This system is represented by the general equation:

$$Force_{Spring} = Constant_{Spring} \times (Travel_{LegA} + Travel_{LegB})$$

The result is a system that has multiple degrees of freedom and multiple solutions for any given state. This is necessary to allow the landing gear to adapt to the unknown terrain below the aircraft. In order to convey the conceptual working of the landing gear, an equivalent two dimensional design is described below:

The initial design (Fig. 2) illustrates the key mechanical linkages and two isolated springs designed to provide resistance. The legs function much like a hinge joint, except that the upper and lower segments are coupled via the geometry of the upper parallelogram and gearing so that the angles of flexion of the upper and lower segments are always equal.

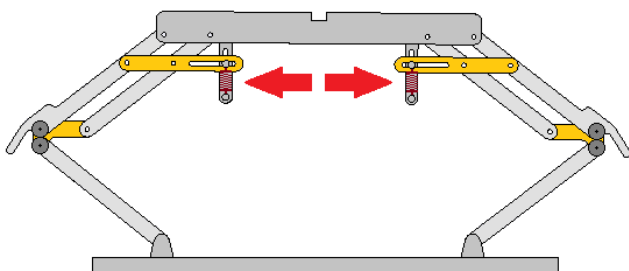

Figure 2 - Mechanical Linkage (Independent)

This restricts the movement of the foot to a vertical path, as shown in Figure 3, which is important as the resistance of each leg must be linear with respect to leg compression across its whole range of movement. If the resistance is non-linear this will cause preferential loading of one leg over the other once the legs are coupled.

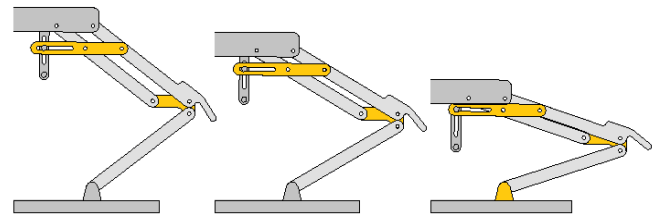

Figure 3 - Restricted Path of Motion

The next key step is to introduce the differential component of the design by linking the two individual springs to form a single combined spring, as shown in Figure 4. This allows loading from one leg to be transferred to the other leg. If both legs are free, as one leg increases in length the other will decrease and vice versa.

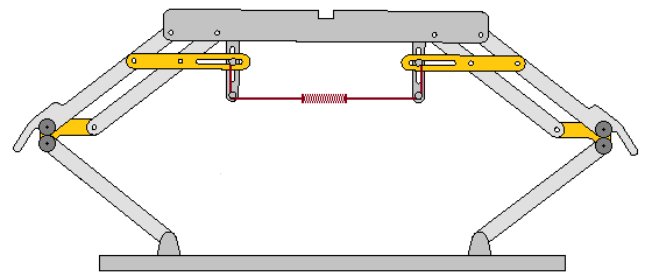

Figure 4 - Mechanical Linkage (Combined)

As such when the landing gear approaches uneven ground, the leg that touches first will retract with very little resistance, as the load is transferred towards extending the opposite leg. Once both legs are touching, the landing gear will then start to bear the load evenly until equilibrium is reached, and will settle to a stable horizontal attitude.

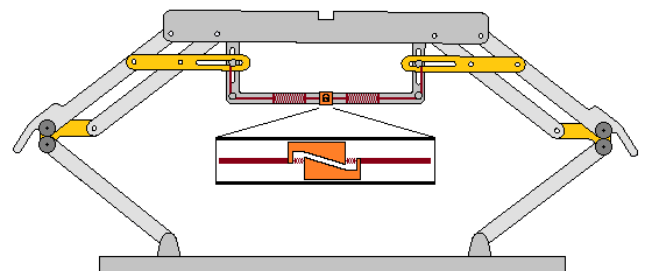

Figure 5 - Mechanical Linkage (Coupled Locking Mechanism)

The final key concept is that the landing gear needs to take advantage of a locking mechanism (Fig. 5), as the aircraft will be susceptible to tipping over if exposed to external forces (e.g. wind, uneven loading, etc). While the exact mechanism used is not critical, it is important that the differential spring is locked in place once the aircraft has landed, thereby turning the system back into a independent suspension system configured to

fit the new terrain. The current design uses a locking mechanism that is load based, so that it will automatically release upon take-off and can therefore be used for multiple landings.

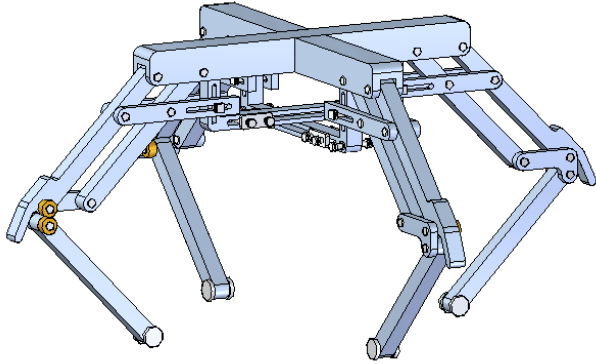

Figure 6 - Complete Landing Gear (Two-Axis)

This two dimensional landing gear system can then be combined into a functional three dimensional system by using two pairs of the system just described (Fig. 6). As the two pairs work on two separate axes, there is no interference between them and the design can be simplified. A three legged or six legged design is also possible, however the differential linkage between the legs becomes more complicated.

It should be noted that there are limits to this design, for example, as the mechanical landing gear does not actively sense its environment, it is not possible for it to differentiate between a tilting of the aircraft's orientation and a tilting of the ground. As a result, if the aircraft touches down in an inclined position, the landing gear will adjust so as to keep the aircraft in that inclined position (which may or may not be stable). Additionally the system requires equal loading of each leg (though the distance travelled may vary), which means the centre of mass of the aircraft must match the center of geometry of the landing gear. A failure to do so will cause the aircraft to lean in the direction of greater mass. In order to overcome these issues, two assumptions are required:

- 1) *The aircraft must initiate landing and continue to land in a near level state (i.e. horizontal)*
- 2) *The aircraft's center of mass must be centered with respect to the landing gear.*

These two assumptions are considered to be reasonable as the aircraft can easily (and should) be designed to have the centre of weight aligned with the landing gear. And the nature of the aircraft (VTOL) means that a landing with forward translation is still possible, as long as touchdown is preceded by a short period of hovering. In fact this very phenomenon is observed in the honey bee [Evangelista et al., 2010]. A failure to meet these two criteria is not fatal, however slight deviations of the settling attitude from the horizontal are likely.

3 Theoretical Analysis

Due to the nature of the design, comprising a modified damped mass-spring, the response of the system can be analyzed as a second order system. First, a classical step response of the system will be investigated. This allows the damping ratio (ζ) to be analyzed to obtain the optimal damping coefficient to achieve critical damping, which as shown later in this section, provides the quickest return to equilibrium as well as the lowest maximum deceleration. This of course assumes that dynamic damping is not included as an option in the setup.

Analyzed as a damped mass spring the landing gear can be modeled as having three components, acceleration by mass, velocity by damping coefficient and position by spring constant.

$$mass(acc.) + damping(vel.) + spring(pos.) = 0$$

Substituting and rearranging using the equations for the natural oscillation frequency and damping ratio, the following parameters and characteristic differential equation can be obtained:

$$\text{natural frequency, } \omega_0 = \sqrt{k/m}$$

$$\zeta = \frac{c}{2\sqrt{mk}}$$

$$\text{damping ratio,}$$

$$\text{characteristic equation, } \ddot{x} + \zeta\omega_0\dot{x} + \omega_0^2 x = 0$$

TABLE I. LANDING GEAR - KEY PARAMETERS

Prototype Landing Gear Parameters		
Parameter	Value	Unit
Prototype Weight	2.956	kg
Maximum Leg Travel	0.140	m
Maximum Terrain Angle	20	deg
Pin / Leg Ratio	8.65	
Natural Frequency, ω_0	11.7	Rad/s
Spring Constant, k	404.6	N/m
Damping Coefficient*, c	69.17	N.s/m

Note: The damping coefficient, c, was calculated based on other known values in order to achieve a critically damped system.

Equations can then be derived for the step response of the system. For each of the three conditions shown below, the general equation is presented, followed by the case specific equations for position and acceleration that account for the specific system parameters listed in Table 1.

Critically Damped (Step Response) – ($\zeta = 1$)

$$x(t) = 1 - e^{-\zeta\omega_0 t} \tag{1}$$

$$x(t) = 1 - e^{-11.7t} \tag{2}$$

$$\ddot{x}(t) = -136.89e^{-11.7t} \tag{3}$$

Under-Damped (Step Response) – ($\zeta = 0.1$)

$$x(t) = 1 - e^{-\zeta\omega_d t} \frac{\sin(\sqrt{1-\zeta^2}\omega_d t + \varphi)}{\sin(\varphi)}; \varphi = \arcsin(\zeta) \quad (4)$$

$$x(t) = 1 - 1.005e^{-1.17t} \sin(11.64t) - 1.477e^{-1.17t} \quad (5)$$

$$\ddot{x}(t) = 134.789e^{-1.17t} \sin(11.64t) + 27.376e^{-1.17t} \cos(11.64t) + 1.728e^{-1.17t} \quad (6)$$

Over-Damped (Step Response) – ($\zeta = 2$)

$$x(t) = 1 - Ae^{\gamma_+ t} + Be^{\gamma_- t}; \gamma_+, \gamma_- = \text{Quadratic Roots}$$

$$A = x(0) + \frac{\gamma_+ x(0) - \dot{x}(0)}{\gamma_- - \gamma_+}; B = -\frac{\gamma_+ x(0) - \dot{x}(0)}{\gamma_- - \gamma_+} \quad (7)$$

$$x(t) = 1 - 1.077e^{-3.135t} + 0.077e^{-43.665t} \quad (8)$$

$$\ddot{x}(t) = -10.590e^{-3.135t} + 147.588e^{-43.665t} \quad (9)$$

These equations are plotted against time in Fig. 7 to show the response of the system to a step input. The critically damped response is the ‘ideal’ response with the position reaching equilibrium as quickly as possible without overshooting. It should also be noted that oscillations are undesired in this design as they increase the travel required by the landing gear as well as the settling time.

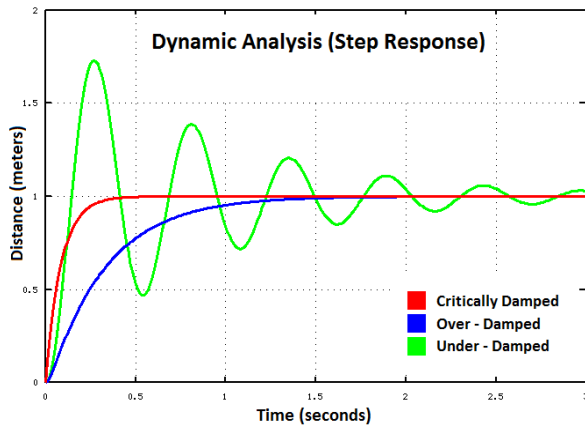

Figure 7 – Landing gear height over time for different damping ratios in response to a step input (Equations 2, 5 and 8).

The second and more poignant analysis is to test how the system responds to a hard landing, for example being dropped from a height of one meter. While typical landings should be much softer than this, occasional hard landings are expected and should therefore be catered for. There are effectively two stages of this analysis, free-fall and impact.

The first is a simple Newtonian problem with the aircraft falling due to gravity for 860mm, reaching an impact velocity of 4.11m/s. The second stage involves the last 140mm of travel where the landing gear is in contact with the ground. This is again modeled with equations derived from the characteristic equation, with an initial displacement of 0.14 metres and an initial velocity of 4.11m/s.

Critically Damped (Landing) – ($\zeta = 1$)

$$x(t) = (A + Bt)e^{-\omega_d t} + C; \gamma_+, \gamma_- = \text{Quadratic Roots}$$

$$A = x(0) + \frac{\gamma_+ x(0) - \dot{x}(0)}{\gamma_- - \gamma_+}; B = -\frac{\gamma_+ x(0) - \dot{x}(0)}{\gamma_- - \gamma_+} \quad (10)$$

$$x(t) = (0.01 - 3.993t)e^{-11.7t} + 0.13 \quad (11)$$

$$\ddot{x}(t) = -119.83e^{-11.7t} \quad (12)$$

Under-Damped (Landing) – ($\zeta = 0.1$)

$$x(t) = e^{-\zeta\omega_d t} [A \cos(\omega_d t) + B \sin(\omega_d t)] + C \quad (13)$$

$$x(t) = e^{-1.17t} [0.01 \cos(11.7t) + 0.352 \sin(11.7t)] + 0.13 \quad (14)$$

$$\ddot{x}(t) = 10.823e^{-1.17t} \cos(11.7t) + 47.723e^{-1.17t} \sin(11.7t) \quad (15)$$

Over-Damped (Landing) – ($\zeta = 2$)

$$x(t) = Ae^{\gamma_+ t} + Be^{\gamma_- t} + C \quad (16)$$

$$x(t) = 0.1006e^{-43.67t} - 0.0906e^{-3.14t} + 0.14 \quad (17)$$

$$\ddot{x}(t) = 191.82e^{-43.67t} - 2.85e^{-3.14t} \quad (18)$$

It can be seen from the response curve (Fig. 8) that the critically damped condition is the most desirable response. It provides the quickest return to a stable position while using almost all the available travel. This is important as excessive damping (as shown by the over-damped condition) will increase the g-force experienced by the aircraft.

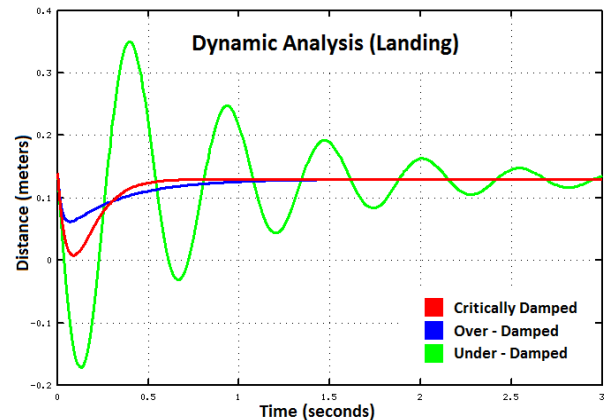

Figure 8 – Landing gear height over time for different damping ratios after being dropped from 0.5m (Equations 11, 14 and 17).

The g-force felt by the aircraft is an important measure as excessive forces can cause damage to the aircraft’s frame and onboard electronics. The g-force experienced by the aircraft is then determined by plotting \ddot{x} the second derivative of the aircraft’s position.

As shown in Figure 9, the over-damped case causes a greater peak deceleration compared to the critically damped ratio. Interestingly however, the under-damped condition, while oscillatory, results in a lower peak deceleration. While this is true, it must be considered that the maximum displacement in this case is greater, and could cause the aircraft to bottom out under real conditions. This would of course cause a jarring impact,

making any other benefits moot. As such, an optimally damped system that is designed to take advantage of the full range of travel will result in the lowest peak g-force possible for a damped spring mass system.

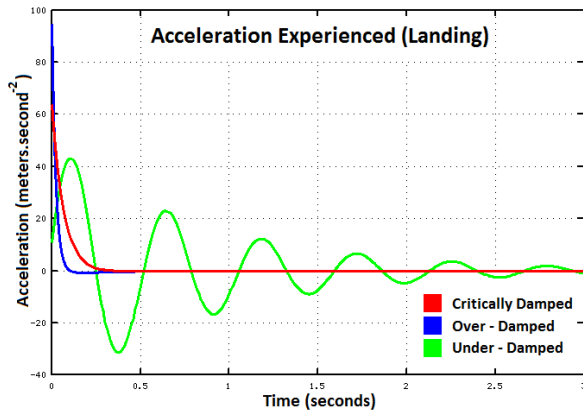

Figure 9 - Acceleration experienced during landing after being released from 0.5m (Equations 12, 15 and 18).

Future designs will investigate the possibility of using a variable damping coefficient in order to further reduce the impact of heavy landings. A variable damping coefficient would allow a more even deceleration profile, which is not possible with the nature of the exponential decay deceleration profile produced by the constant damping coefficient.

5 Simulation of Landing Gear

With a sound theoretical basis, the landing gear was then designed and simulated using the CAD program SolidEdge® and add-on program Dynamics Designer®. This allowed testing of the mechanical linkages as well as the dynamics of the system. Simulations involved dropping the landing gear on various uneven surfaces and observing the results.

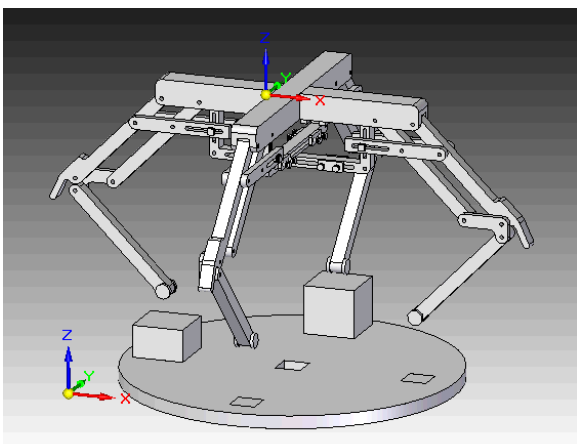

Figure 10 - Illustration of simulation of landing gear

The simulation allowed the design to be tested and refined, and additional features to be implemented such as mechanical stops on the upper limbs to prevent hyper-extension of the joint. The only non realistic assumption made in the simulator was of frictionless joints. The landing gear performed well, with only very

minor levels of tilt being introduced (<1 degree) due to the reaction force (mass by acceleration) of the opposite extending limb. In practice, the non-zero friction of the joints would overcome this effect and probably cause a slight lean towards the low side of the terrain (the angle of lean would of course be dependent on the magnitude of joint friction).

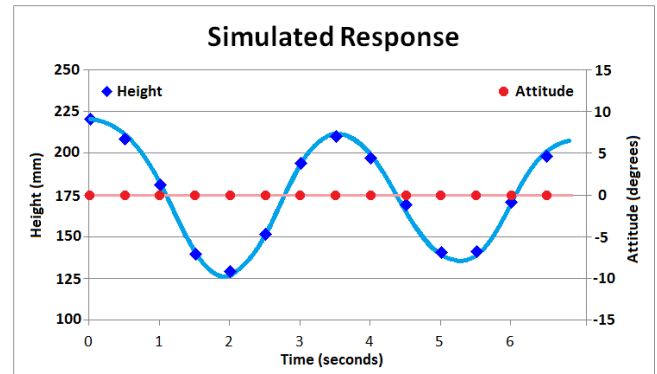

Figure 11 - Results of a simulation of the landing gear. The landing surface comprises one 25mm block and a second 37.5mm block placed on a horizontal plane resulting in tilts of 7.1° and 10.6° along the X and Y axes respectively.

A representative example of a simulated landing is shown in Figure 11, where it can be seen that when dropped from a height of 225mm the un-damped landing gear oscillates up and down, however the attitude of the landing gear cross beam remains at a near constant zero degrees attitude. This re-affirms the assertion of the theoretical design that, so long as the aircraft's initial attitude is horizontal, and the mass is centralised, the aircraft will land level regardless of the terrain. The oscillation seen in the above figure is due to the fact that the simulation was undamped, with the apparent damping attributed to losses in the simulation. Note: The spring and geometric constraints were the only information provided to the simulation, with no implicit constraint of being an undamped oscillator, as a result there are minor errors accumulated each time step for each joint, resulting in an overall loss (damping) seen in the graph.

6 Physical Implementation

Based on the above theory and simulation, a prototype landing mechanism was built with minor modifications made for ease of manufacturing.

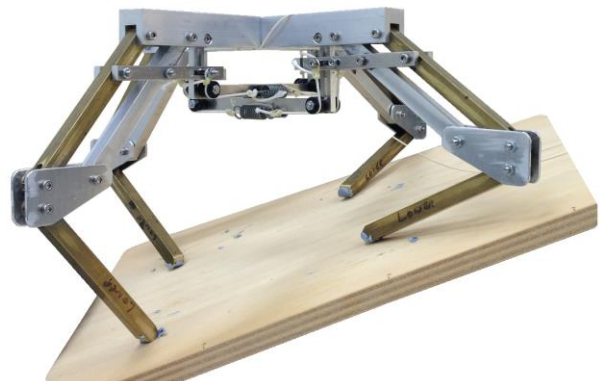

Figure 12 - Prototype Landing Gear (20 Degree Incline)

The first prototype was designed as a proof of principle and for this reason, ease of manufacture was given preference over the use of light weight materials. With a total weight of 1330g, this prototype was not intended to be flown on the multi-rotor test platform.

All members were made from solid aluminum except for the outer limbs which were of brass. The gears (hidden from view at the “elbow” joint) were made from steel.

The total weight of the assembly was 1330g with a pair of 0.15kg/mm springs being used for each set of legs. The tensile forces of the springs were transmitted via low stretch nylon cord and plastic pulleys. Although this first prototype did not implement the locking mechanism, by increasing the friction in each of the joints through tightening, overall stability was achieved.

The reason this works is that the frictional dampening present can be approximated as coulomb friction, whereby the friction is independent of sliding velocity, being instead a function of the coefficient of friction and the force normal to the contacting plates. As loading of the landing gear is perpendicular to the contact surfaces, loading force should not significantly affect the friction present at these joints. As such, stability is maintained under stationary conditions (under small load) but the landing gear is free to move and act as a differential during dynamic movements (under high load). While this form of damping will lead to a small bias against being level (due to the friction being independent in each leg), this should not significantly affect the overall attitude.

7 Landing Experiment #1

Landing experiments were conducted using the prototype landing gear as described above. Initial tests involved dropping the landing gear on to different surfaces from various heights. The experiments started with a flat horizontal surface and eventually progressed to surfaces with four unique heights, one for each leg (as shown in Fig. 13).

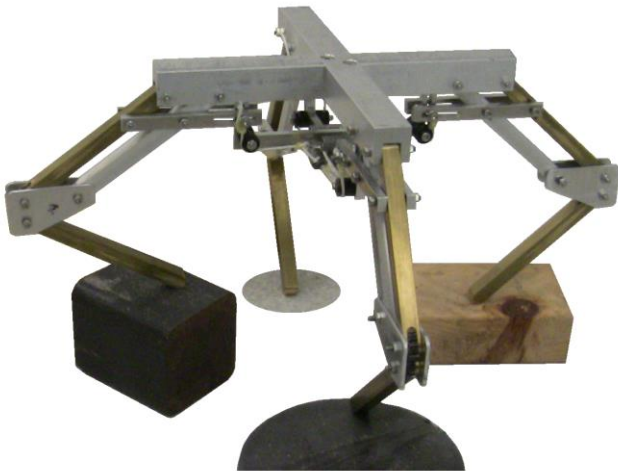

Figure 13 - Example showing the final settling attitude of the landing system when dropped onto a substrate in which the four feet are at different heights.

A number of trials were then carried out in order to determine the performance and reliability of the landing gear. The landing gear was initially supported by two loops of string slung under the centre of the cross beam,

and dropped from a height of approximately 500 mm. A total of 10 drops per incline were conducted, with the final settling orientation of the base platform then photographed. These photos were then digitally analyzed to provide the mean settling angle and variability. The results are shown in Figure 14.

The device performed well, with landings on both horizontal and 10 degree inclines centered around 0 degrees attitude. In the more extreme case where the landing gear was dropped on a 20 degree incline (near the mechanical limit of the landing gear) the results were still good, with mean settling attitude of -2.45 degrees and a standard deviation of 1.87 degrees. While not included in this test, a number of trials were also conducted on uneven terrain such as a saddle geometry. Unlike inclines this introduces an uneven loading between the two axes, however each pair still distributes its load evenly between each leg and thus mains an overall level attitude.

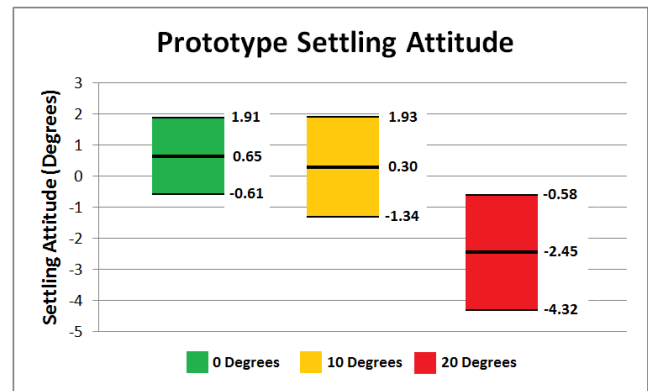

Figure 14 - Settling attitude (mean +/- SD) of prototype device for three test conditions.

Analysis of these results revealed that there were several factors that contributed to the variance in the settling attitude. The first factor is the non-zero friction present in the joints, which creates resistance and tends to lean the aircraft in the direction of the incline. This is most noticeable in the 20 degree case.

Additionally while every effort was made to release the landing gear at a perfectly level attitude, variation of a few degrees in release angle was inevitable and would have added to the variability. This, however, is likely to be more representative of real world conditions.

Lastly, it is expected that the results will be better once implemented on the aircraft, as the greater moment of inertia provided by the aircraft will help prevent undesired pitching and rolling caused by the non-zero friction joints. As such, we conclude that provided the aircraft begins its landing from a horizontal attitude and the slope of the terrain does not exceed 20 degrees, the landing gear will be able to provide a safe, stable landing.

8 Light Weight Prototype

With the success of the first prototype as a “proof of concept”, a second prototype was manufactured out of carbon fiber and aluminium in order to reduce the overall weight. Key components such as the gears, pins and springs remain steel due to strength requirements. The total weight reduction achieved for this prototype was 1002g, bringing the total down to a realistic 368g.

This carbon fiber landing gear is to be tested in

real world conditions using the multi-rotor test platform shown in Figure 1. This will allow further refinement of the landing gear system as well as the testing of novel bio-inspired landing strategies [Evangalista et al., 2010].



Figure 15 – Second prototype manufactured out of carbon fibre with a total weight of 378g suitable for small scale UAV use.

It should also be noted that while the landing gear is designed to be able to “fall” safely from 500mm, the nature of a multi-rotor aircraft means that landings should be gentle and small changes in attitude can in fact be countered by the aircraft’s onboard sensors and control system.

9 Discussion

The advantage of this design is that it takes advantage of mechanical processing and as such does not require any power, active control system, or introduce any computational lag time. And, while not realized in the current prototype, the system has the potential to be miniaturized and made light weight. Alternative designs for the differential mechanism such as a pneumatic or hydraulic system can also be considered. Each design would work with its own modifications, the limiting factor being ease of manufacture.

Future aims for this project include further analysis of this system by filming a series of landings with a high speed camera and analyzing the kinematics. Additionally a light weight prototype is to be manufactured for use on a small rotorcraft, allowing the testing of bee-like landings.

In terms of practical applications, it is likely that this design could be implemented as part of an integrated approach that uses both active and passive designs. For example the passive landing gear could take care of the bulk of the processing, while active control is used to change other variables such as the spring and/or damping constants. The aircraft could then adjust the damping ratio depending on the expected type of landing, and also vary the spring constant once landed in order to raise or lower the height of the aircraft. However, these considerations are beyond the scope of the present study.

10 Conclusion

The current standard for micro UAVS is to use an actively controlled system for landing or a nearly rigid,

static frame where finesse is not required. While active systems do provide a greater level of control, mechanical design can often be a useful partner by already providing the first level of control through the mechanical design itself. As micro UAVs become smaller and smaller, intelligent mechanical design is well placed to provide useful solutions to some of the roadblocks that are encountered during the miniaturization process. This paper demonstrates a landing gear design that is capable of self-leveling without the need for any sensing or control, and which can be easily miniaturized.

Acknowledgements

This research was supported by the ARC Centre of Excellence for Vision Science, and by a Queensland Government Premier’s Fellowship.

A Attached Video

The short video accompanying this paper firstly shows examples of the landing gear’s final settling position after being dropped from a height of one meter, as per the landing experiment in section 8 of this paper. Following this is a real time and slow motion video capture of a landing on a 20 degree incline. It should be noted that this test approaches the limit of the landing gear’s capability and a momentary touchdown of the right knee against the board is noticeable, as well as some loss of traction with the board due to the steep angle. Under normal operating circumstances the aircraft would be able to perform a hover just before touchdown, permitting a much gentler impact.

References

- [Anderson et al., 2009] M. L. Anderson, C. J. Perry, B. M. Hua, D. S. Olsen, J. R. Parcus, K. M. Pederson and D. D. Jensen, “The Sticky-Pad Plane and other Innovative Concepts for Perching UAVs,” *47th AIAA Aerospace Sciences Meeting Including The New Horizons Forum and Aerospace Exposition, January 2009, Orlando, USA*, January 2009.
- [Bayraktar and Feron, 2008] S. Bayraktar, E. Feron, “Experiments with small helicopter automated landings at unusual attitudes,” *Arxiv preprint*, 2008.
- [Desbiens and Cutkosky, 2010] A. L. Desbiens and M. R. Cutkosky, “Landing and Perching on Vertical Surfaces with Microspines for Small Unmanned Air Vehicles,” *Journal of Intelligent Robot System*, Vol.57, pp. 313-327, 2010.
- [Desbiens et al., 2011] A. Desbiens, A. Asbeck, and M. Cutkosky, “Landing, perching and taking off from vertical surfaces,” *The International Journal of Robotics Research*, vol. 30, issue. 3, pp. 355-370, January 2011.
- [Dollar and Howe, 2005] A. M. Dollar, R. D. Howe, “Towards grasping in unstructured environments: grasper compliance and configuration optimization,” *Advanced Robotics*, ISSN 0169-1864, Volume 19, Issue 5, pp. 523 – 543, June 2005.
- [Doyle et al., 2013] C. Doyle, J. Bird, T. Isom, C. Johnson, J. Kallman, D. Bareiss, D. Dunlop, R. King, J. Abbott, and M. Minor, “Avian-Inspired passive perching mechanism for robotic rotorcraft,” *Mechatronics, IEEE/ASME Transactions on*, vol. 4,

- issue. 2, pp. 506–517, April 2013.
- [Evangelista et al., 2010] C. Evangelista, P. Kraft, M. Dacke, J. Reinhard, and M. V. Srinivasan, “The moment before touchdown: landing manoeuvres of the honeybee *Apis Mellifera*,” *Journal of Experimental Biology*, 213: 262-270, 2010.
- [Kovač et al., 2010] M. Kovač, J. Germann, C. Hürzeler, R. Y. Siegwart, and D. Floreano, “A Perching Mechanism for Micro Aerial Vehicles,” *Journal of Micro-Nano Mechatronics*, Vol.5, No.3, p. 77, 2010.
- [Maltby, 1960] L. J. Maltby, “Landing Gear for Helicopters,” U.S. Patent 2 933 271, April 19, 1960.
- [Mellinger et al., 2010] D. Mellinger, M. Shomin, and V. Kumar, “Control of Quadrotors for Robust Perching and Landing,” *Int. Powered Lift Conference*, Philadelphia, PA, Oct 2010.
- [Perdue, 1954] L. J. Maltby, “Landing Gear for Helicopters,” U.S. Patent 2 933 271, April 19, 1960.
- [Rippere and Wiens, 2010] T. B. Rippere, G. J. Wiens, “An Approach to designing passive self-leveling landing gear with application to the Lunar Lander,” Proceedings of the 40th Aerospace Mechanisms Symposium, NASA Kennedy Space Centre, May 7-9, 2010.
- [Sreetharan and Wood, 2012] P. S. Sreetharan, R. J. Wood, “Passive Torque Balancing in a High-Frequency Oscillating System,” U.S. Patent Application Publication 2012/0292438 A1, November 22, 2012.
- [Stancliffe, 1977] F. S. Stancliffe, “Landing Gear for an Aircraft including Expansible Wheels,” U.S. Patent 4 046 339, September 6, 1977.