

# Past, Present and Future Challenges of the Marine Vessel's Electrical Power System

Espen Skjong, Rune Volden, Egil Rødskar, Marta Molinas, *Member, IEEE*, Tor Arne Johansen, *Senior Member, IEEE*, and Joseph Cunningham

**Abstract**—The evolution of the use of electricity in marine vessels is presented and discussed in this article in an historical perspective. The historical account starts with its first commercial use in the form of light bulbs on the SS Columbia in 1880 for illumination, going forward through use in hybrid propulsion systems with steam turbines and diesel engines and then transitioning to the present with the first fully electric marine vessel based entirely on the use of batteries in 2015. Electricity use is discussed not only in the light of its many benefits but also of the challenges introduced after the emergence of the marine vessel electrical power system. The impact of new conversion technologies like power electronics, battery energy storage, and the DC power system on overall energy efficiency, power quality, and emission level is discussed thoroughly. The article guides the reader through this development, the present and future challenges by calling attention to the future research needs and the need to revisit standards that relate to power quality, safety, integrity, and stability of the marine vessel power system, which are strongly impacted by the way electricity is used in the marine vessel.

**Index Terms**—Marine vessel electrical power system, diesel-electric propulsion, steam turbine, power electronics, battery energy storage, power quality, harmonics

## I. INTRODUCTION

**S**TARTING with the earliest records of a commercially available shipboard electrical system which date back to the 1880s with the onboard dc system of the *SS Columbia*; the invention of the AC induction motor, the transformer, and the diesel engine triggered new research and development toward the end of the 19th century and the beginning of the 20th. In this period, the initial steps were made in research related to submarines, batteries, steam turbines, and diesel engines. The two most important developments before WWI were the first diesel-electric vessel (*Vandal*) in 1903 and the first naval vessel with electric propulsion in 1912 (*USS Jupiter*). During the period of rising tension that preceded WWI the first cargo vessels with turbo-electric propulsion were conceived and developed in the United States and the United Kingdom. The

E. Skjong, R. Volden and E. Rødskar are with Ulstein Power & Control AS, 6018 Ålesund, Norway

E. Skjong, M. Molinas and T. A. Johansen are with the Department of Engineering Cybernetics, Norwegian University of Science and Technology, 7034 Trondheim, Norway

E. Skjong and T. A. Johansen are with the Centre for Autonomous Marine Operations and Systems (AMOS), Norwegian University of Science and Technology, 7052 Trondheim, Norway

J. Cunningham is an adjunct lecturer, engineering development and history, at various institutions and associations.

Email: espen.skjong@ulstein.com, rune.volden@ulstein.com, egil.rodskar@ulstein.com, marta.molinas@ntnu.no, tor.arne.johansen@itk.ntnu.no, joscunningham@gmail.com

outbreak of WWII stimulated new developments that brought the T2-tanker with turbo-electric propulsion into the picture. Nuclear powered vessels emerged in the late 1950s and the first passenger liner to use alternating current was inaugurated in 1960 (*SS Canberra*), 70 years after the invention of the alternating current motor. In the period 1956-1985, the power electronics revolution triggered by the innovative solid-state technology marked the beginning of a new era for marine vessels; the era of the all-electric vessel. As a result of that, *Queen Elizabeth II* was inaugurated in 1987 with the first diesel-electric integrated propulsion system. And in the last two decades, the marine vessel community has witnessed the development of the first vessels having LNG as fuel. In January 2015, marking the start of the era of the *all-electric vessel*, the world's first purely battery-driven car and passenger ferry *Ampere* was placed in use and is being regularly operated in Norway. Fig. 1 guides the reader through the milestones in the evolution of the the marine vessel electrical power system from 1830 to 2015.

This new era of electric marine vessels does not come without challenges, however. In what follows, the paper highlights the different stages in the evolution of the marine vessel's development and the impact of electricity use in this evolution. Following the historical account, the paper moves towards modern electric ship propulsion discussing the new challenges of moving towards hybrid AC/DC and pure DC power systems, the challenge of electrical stability, harmonic pollution, and power quality in stand-alone microgrids like the marine vessel, the role of battery energy storage systems, and the move towards emission free operation among others. Along with these challenges, potential solutions and possible roads to follow are presented.

## II. EARLY STEPS OF THE MARINE VESSEL ELECTRIFICATION

The first recorded effort to apply electric power on a marine vessel occurred in the late 1830s after Moritz Hermann Jacobi of Germany invented a simple battery powered direct current (dc) motor which was installed experimentally on small boats [1]. It suffered from numerous imperfections and there was no immediate adoption of electric propulsion for ships. The first successful application of electric power on ships was that of gun firing circuits in the 1870s. The development of arc lamps for illumination of streets and public spaces was followed by arc lamp searchlights on ships to illuminate attacking ships and blind enemy gunners. Luxury liners were equipped with call bells for the convenience of passengers [2].

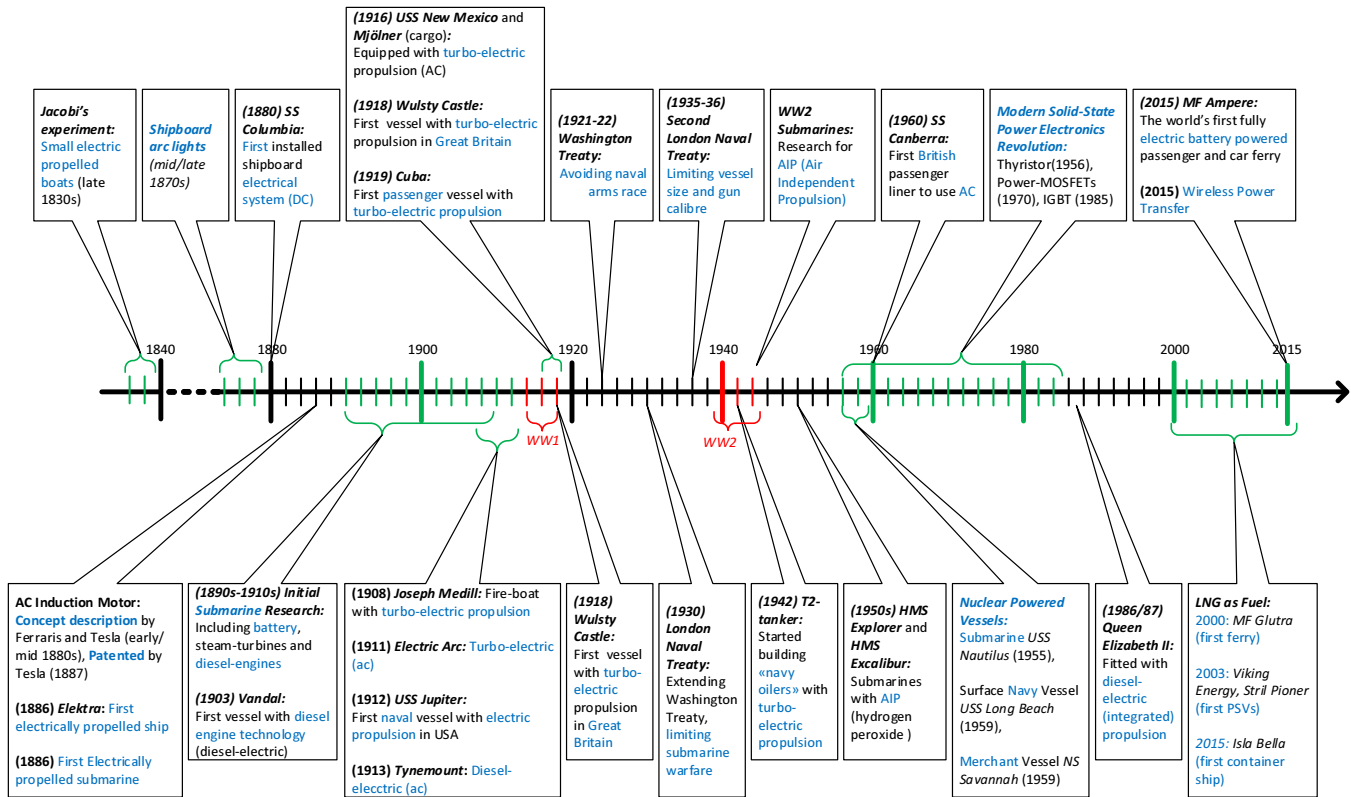

Fig. 1. Historical highlights of the development of the Marine Vessel's Power System from 1830 to 2015 [2].

The development of incandescent lighting by Thomas Edison and others was followed by an installation on the passenger and freight vessel *SS Columbia* in 1880. That consisted of 120 lamps powered by a set of dynamos; the system was crude with lead wires functioning as fuses and lamp intensity was regulated only by the engine room crew's adjustment of the generators according to the appearance of the lamps [3]. Nonetheless, it led the *US Bureau of Navigation* to mandate additional installation of electric lights. Soon after, electric motors were installed in ventilation and gun firing circuits. In 1896, the *USS Brooklyn* was fitted with an 80 volt dc electrical system to operate winches, deck machinery, and gun mounts [2]. Most installed shipboard power systems were dc as alternating current (ac) motors were not yet perfected. The first successful electrically powered vessel was the *Elektra*, a passenger ferry with a capacity of 30 persons, built by the German firm *Siemens & Halske* in 1885. Measuring 11 meters long by 2 meters wide, it was powered by a 4.5 kW motor supplied by batteries [4].

#### A. Alternating Current Motor and Transformer

The development of ac motors based on the inductive effect of phase displaced conductors; primarily by Nikola Tesla (US), Galileo Ferraris (Italy), and Michael Osipowitch Dolvio-Dobrowolsky (Germany), made possible an alternative; however, the reliable dc motors developed by Frank Sprague (US) and others tended to favor the use of direct current motors. Regardless, ac research continued; George Westinghouse took the lead in the United States. Often overlooked

was the Hungarian team of Károly Zipernowsky, Ottó Bláthy, and Miksa Déri, (*ZBD*) whose closed core transformer of high efficiency made practical ac power distribution and was adopted by Westinghouse [5], [6].

Still, the issue of ac power factor (the useful power delivered after losses due to inductive and capacitive reactance) constrained the adoption of ac for commercial power, railways, and on ships. However, dc systems were heavier and larger; thus in an effort to reduce weight ac systems were designed for frequencies up to 400 Hz but the mechanical frequency converters of the time were cumbersome. Practical ac propulsion was demonstrated in 1908, though without modern power electronics control was complex; effected by voltage and frequency changes and variations in pole connections. It is said that the complexity of ac systems led the British Navy to retain dc systems, even though Germany followed the lead of the US which had adopted ac systems in 1932 [2].

#### B. Turbo-electric Powered Vessels

In the early 1900s, Britain favored the development of steam turbine drive systems with reduction gears while the US focused on electric drive with the first turbo-electric drive installed in 1908. Rated at 400 shaft horsepower, it was installed on the *Joseph Medill*, a fireboat [1], [7]. Four years later, the collier *USS Jupiter* became the first naval vessel to adopt turbo-electric propulsion. That was an experiment, the ship also included a diesel engine and a direct coupled steam turbine. The 3,500 hp turbo electric system supplied by *General Electric* was deemed a success and the Navy decided

to convert all front line battle ships to electric power. The *Jupiter* went on to become the first aircraft carrier the *USS Langley* [8], [9].

The first battleship to adopt turbo-electric propulsion was the *USS New Mexico*. Launched in 1914, it was equipped with a pair of 11.5MW 3,000/4,242 volt dual voltage, variable frequency generators that powered four 7,500 hp 24/36 pole induction motors and was capable of a speed of 21 knots. The shaft alley was shorter and thus less of a target, and fuel economy was improved substantially. All that came at the expense of weight the electric motors and controls were heavy though reversal was accomplished easily by the switching of circuits with no need to change steam systems [2], [8].

The first passenger vessel to incorporate the new system was the *Yorktown*. Built as the *Cuba* in 1894, after a 1916 wreck it was reconfigured as a turbo electric system in 1919 [2], [10]. Electric drive was not limited to the US. In Sweden the shipbuilder *Rederiaktiebolaget Svea* constructed in 1916 a pair of cargo ships. One of them, the *Mimer*, was constructed with steam power; the other, the *Mjölner*, was equipped with electric drive; radial flow reaction turbines powered ac induction motors coupled to a single shaft through reduction gears [11]. Two years later the cargo ship *SS Wulsty Castle* was constructed in Britain with a similar drive system.

While the steam engine was practical for land based power generation, the low efficiency of fuel consumption led to a search for a better method. Rudolf Diesel, a German inventor, patented the diesel engine in 1892 and licensed production in Sweden and Russia. In 1903, constant speed diesel engines coupled to an electric transmission were installed in the *Vandal*, a river barge sailing on the Volga River that transported coal to St. Petersburg and also to Finland [1], [2].

### C. Submarines

The availability of electric power for illumination, communication, and propulsion had fostered the concept of an all-electric ship. It was therefore logical to extend that concept to submarines for which a practical power source had remained an elusive goal. There had been much experimentation with the concept of underwater crafts during the 19th century; propulsion varied from manual to stored compressed air, even pressure from chemical reactants. In 1885, the French designer Claude Goubet had introduced electric propulsion with a pair of experimental submarines. By 1900, France, the United States, and Britain were exploring the submarine concept, the latter two nations expanded on the work of John Philip Holland. Most of those schemes focused on the internal combustion engine for surface operation and the charging of batteries for use when submerged [2], [12].

### D. Effect of World Wars I and II

Germany made extensive use of submarines to attack ships during WW I; subsequently the United States, Britain, and Japan engaged in an arms race. That was stopped by treaties in the 1920s which limited or forbade entirely the construction of new, or the reconstruction of, existing vessels thus effectively halting technical development. Subsequent agreements sought

to continue limits imposed on navies until Japan withdrew from the agreements in 1934. An arms race followed, and the United States commenced construction of battleships though electric propulsion was not adopted due to concern for electrical system vulnerability to damage during battles and also a concern for the additional weight which could be better utilized for weapons or armor [2], [13].

Electric propulsion was adopted by the United States for the navy oiler, a tanker that supplied oil to ships at sea. With a maximum power of 7,240 hp and a speed of 15 knots it had a range of 12,600 miles. 481 were constructed during the war [2]. Diesel-electric submarines of various types were constructed in large numbers during World War II.

## III. TOWARD MODERN ELECTRIC SHIP PROPULSION

The development of the mercury pool rectifier for power conversion in the early 1900s produced a practical alternative to mechanical power conversion; both as a rectifier and also as an inverter. Solid state power electronics emerged in the 1960s and 70s to enable significant advances in the power systems of ships. The first British passenger liner with alternating current propulsion was the *SS Canberra* in 1960. Equipped with three 6,000 volt synchronous motors that produced 85,000 hp, the most powerful ever installed on a ship, they enabled it to cruise at 27.5 knots. Separate generators supplied non-propulsion loads [14], [15].

The use of power electronics to maximize fuel efficiency became a trend in the 1980s. In 1984, the *Cunard Line* re-equipped the *Queen Elizabeth II* with nine German *MAN* diesel engines coupled to an electric transmission. The system was designed such that only seven engine sets were required to maintain the design speed of 28.5 knots, which thus effected a fuel savings of 35% [2].

Power electronics found extensive application in off-shore vessels such as Platform Supply Vessels (PSV) and other service ships. Dynamic Positioning (DP) systems required sophisticated control systems to maintain position in specialized operations. Diesel electric propulsion was the standard method, though LNG was also adopted in the early 2000s. Nuclear reactors for steam turbine systems were developed initially for submarines the *USS Nautilus* of 1954 being the first such vessel, the *USS Long Beach* the first nuclear powered surface vessel followed in 1959. That same year the first passenger and cargo ship, the *NS Savannah* was launched [16], [17].

In the constant drive for greater fuel economy, hybrid drive ships have been developed; the propulsion supplied by gas turbine direct drive or electric motors supplied by diesel engine-generator sets, the system configured as needed to maximize fuel efficiency.

Fuel cells and Battery Energy Storage Systems (BESS) to adapt ships to renewable energy sources have emerged recently. In January 2015, the world's first fully electric passenger and car ferry, the *MF Ampere* was launched. Capable of accommodating 120 cars and 360 passengers, it makes a 30 minute crossing between Oppedal and Lavik near Bergen, Norway. One MW of battery capacity supplies the ferry, the

battery sets charged when the vessels arrive at the docks. Operated by *Norled AS*, the ferry is a product of the *Fjellstrand* shipyard and *Siemens AS* [2].

#### IV. PROPERTIES AND CHALLENGES OF THE MARINE VESSEL'S POWER SYSTEM

Electrical power systems for marine vessels have existed for more than 100 years, and history has shown a high level of research and innovation, to bring the early applications of shipboard electricity of the 1880s to modern power systems. Vessels today often consist of an ever increasing electrical load: The majority of the propulsion systems and auxiliary loads, such as weapon systems in naval vessels, hotel and service loads in a cruise vessel, and station-keeping (DP) systems for subsea operations, are of an electrical type. The power is, in general, generated from prime movers using e.g. diesel and/or gas, or from nuclear plants with a turbo-electric configuration. In many modes of operation the power systems need to be reliable and exercise a high level of survivability. *The Naval Sea Systems Command* states the design philosophy for naval power systems very well [18]–[20]:

*The primary aim of the electric power system design will be for survivability and continuity of the electrical power supply. To insure continuity of service, consideration shall be given to the number, size and location of generators, switchboard, and to the type of electrical distribution systems to be installed and the suitability for segregating or isolating damaged sections of the system.*

This design philosophy does not only apply to naval ships. Vessels that exercise dangerous operations, such as DP operations near offshore structures, or operations in which in general, any failure could have a high economical or environmental consequence, need power systems with high levels of reliability and survivability and electrical stability.

On the commercial side the vessels should be fuel efficient, thus keeping the emissions (air pollution) to a minimum and the fuel costs low. One of the most critical issues facing ship owners and builders today is stricter regulations for emissions, such as the *International Maritime Organization's* (IMO) *MARPOL* air pollution regulations [8], [21]. Due to these stringent exhaust emission regulations, a lot of focus has been devoted toward technology such as exhaust catalysts, electronically injected common rail diesels, and waste-energy recovery, such as heat-exchange systems. Also alternative fuel, such as LNG, has also found its way to a broader market.

Properties (and requirements) such as reliability, survivability, and continuity of electrical power supply, sustainability, and efficiency can all be related to the power system's design, electrical stability, and manner of operation. In the following some of the aspects of the shipboard power system's ongoing design trends, properties, and challenges will be discussed. For a thorough introduction to the most common shipboard power system designs it is referred to [22].

##### A. AC vs DC

The early shipboard power systems were of a dc type, but with the introduction of the ac motor this changed and ac

became the main trend in shipboard power system designs. One of the reasons for this was that the early dc systems (without power electronics) needed rotating devices to transform the power from one voltage level to another [23]. The ac power system has been the most used power system in marine vessels, but now, with modern power electronics and other technological advantages, the discussion of using dc or ac distribution in shipboard power systems has been brought to the table and some of the key points whether to use ac or medium-voltage dc (MVdc) are (adopted from [20], [24]–[26]):

- **Impedance:** MVdc power systems are capable of providing greater energy dynamics than the classical ac power systems due to elimination of many components for power conversion and optimizing the use of the cables (only ohmic resistance). The dc distribution doesn't experience skin effect in the power transmission, as is the case in ac transmission. Also, due to the lack of a fundamental frequency, the dc system does not have a power factor, and depending on the voltage levels, the weight of cables may decrease for a given power level. Unlike the dc system, the ac system has reactive currents that increase the losses, which thus reduce the energy transportation capability. Cable impedance in an ac system causes a current-dependent voltage drop along the cable, however the impedance of the cable automatically limits the short-circuit currents. In dc systems only the (very low) ohmic resistance of the cables limit the short-circuit currents, thus all parts of the power system are equally effected by a short-circuit at an arbitrary position. This effect, and the missing natural zero-crossing of the ac current makes it hard to break a connection (bus-tie/circuit breaker) or even limit the dc current, which may endanger power converting devices that contain power electronics.
- **Prime mover speeds:** In dc systems the speeds of the prime movers can be altered, as the prime mover speeds are largely decoupled from the power quality of the grid. Since frequency control is not a concern, the prime movers can run at optimized speeds (relative power demand with the objective of increased fuel efficiency) connected to generators with an arbitrary number of poles.
- **Connection of paralleled power sources:** In ac systems paralleled power sources must be both voltage and phase matched before being connected to the power system. In a dc system the phase matching is not needed, resulting in a faster power generation response time.
- **Power Electronics Conversion System:** In dc systems, medium or high frequency transformers (dc-ac-dc electronic transformers) can be used resulting in a smaller footprint. On the other hand, in ac systems the transformers make an easy and reliable adaption of the voltage levels, however the conversion system often includes a dc-link stage. Hence, using a cable connection instead of the internal direct connection of the dc-links between the source- and load-side of the converter leads to a dc grid. Linking the dc-links from the converters directly will

demand a sufficiently high dc-link voltage in the order of 10kV. Using back-to-back converters with internal dc-links, which are state of the art, this dc-link voltage can be reduced by adapting to the high ac-side voltage by a transformer, at the cost of increased weight and space and reduced efficiency.

- **Fault currents and circuit breaker technology:** In dc systems the fault currents can be controlled to levels considerably lower than in ac systems. This is because power electronics can be used instead of conventional circuit breakers. Lower fault currents will also reduce damage during faults. On the other hand, the ac systems can use much simpler circuit breaking technology than dc systems as electrical arcs clear at zero-crossing of the current.
- **Acoustic signature:** The dc system does not have a significant acoustic signature, as is the case with ac systems due to a common fundamental frequency. This can be an important feature for naval vessels. However, the constant magnetic field created by dc current can leave a residual magnetic field in ferrous materials, which contributes to the overall ship magnetic signature. This tends to be, among other things, a disadvantage with regards to mines and sensor/equipment interference.
- **Weight and space:** In dc systems, high-speed gas turbines can be used in conjunction with high-speed generators, without the need for reduction gears for frequency control, which is often the case in ac systems. A mated high-speed gas turbine and generator enables a shorter generator with reduced footprint. This is desirable due to space and weight savings. For constant power, the dc system needs only two conductors compared to the ac system, which needs three. Removing one conductor is beneficial due to weight savings.

New technological advances, such as the modular multilevel converters (MMC) can, in special configurations, solve many of the issues and challenges of dc power grids, thus making the dc system a more interesting solution in shipboard power systems than before. Even though the MVdc solution may lead to reduced weight, increased efficiency, and offer high-energy transport capability at low losses, challenges such as short-circuit currents, dc-breaker technology, and system standardization must be solved [24]. The different power system solutions, whether it is pure ac, a hybrid between ac and dc or pure dc, have different properties, advantages and disadvantages. The choice of power system (pure ac, ac/dc or pure dc) will be strongly dependent on, among others, available technology and different components from different manufacturers, developer and customer preferences, most economical solution, type of equipment connected to or powered by the power system, possibilities for energy storage, space and weight requirements, the level of redundancy and rules and regulations from classification entities. These aspects, along with an economical point of view, will influence in shaping the power system solution.

## B. Marine Vessel Power Systems and Microgrids

Microgrids are electrically and geographically small power systems capable of operating connected to, or islanded from, a national grid [27]. In islanded mode, the microgrid has strict requirements imposed such as energy independence and service quality for an extended period. Marine vessel's power systems are indeed microgrids; they are isolated (and islanded) while at sea) and part of a terrestrial grid while docking and connected to shore power. Shipboard power systems have a lot in common with terrestrial stand-alone microgrids; many of the methods and a lot of equipment and components are the same [28]. In addition many control strategies and design principles used in microgrids may be applicable for shipboard power systems, and also the other way around. Examples of such control strategies and design principles are voltage and frequency control schemes, power quality improvement strategies, power sharing methods for multiple distributed generators, and energy management systems [29]–[33]. A thorough overview of technical cross-fertilization between terrestrial microgrids and ship power systems is presented in [27]. Some of the main differences between a shipboard microgrid and larger terrestrial (commercial) grids are summarized in the following [20], [27]:

- **Frequency:** The shipboard power system's fundamental frequency cannot be assumed constant. Due to limited rotational inertia of the prime movers and the generators, rapid load changes can cause fast acceleration and deceleration of the motor shafts, which causes frequency fluctuations. Such fluctuation may last for a couple of seconds until the speed of the shafts reach a steady state that coincides with the reference frequency.
- **System analysis:** In analysis of a commercial grid all the system's time constants are quantified and used to analyze the problem by time-scale separation. However, such analysis is not easy to conduct in a shipboard power system due to the principal time constants for motor dynamics, electrical dynamics, and controls which all lie in the same time range of milliseconds to seconds.
- **Planning of power generation:** In a commercial grid the power delivered by each generating unit is scheduled. The difference between consumed and produced power is regulated through equipment acting as swing generators. This is not the case in a shipboard power system as all the generators share the active and reactive power through fast exchange of load-sharing information, which amplifies the paralleled generators' dynamics. Hence, instead of generator scheduling the shipboard power generation exhibits load sharing, which is often realized by generator droop control.
- **Electrical distances and load flow:** In the commercial power sector it is important to model the electrical distances (transmission lines) in the power distribution to achieve the right dynamics and proper voltage regulation. This is not the case in a marine vessel's power system as the electrical distances are short, thus trivializing the load-flow problem. The short electrical distances result in low impedance which increases the coupling between the

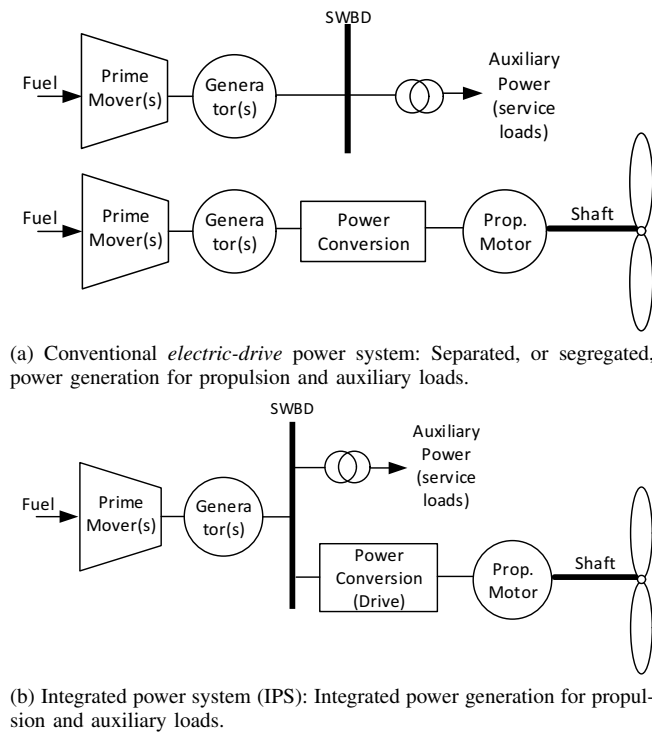

Fig. 2. Simplified drawing illustrating the main structural difference between conventional and integrated power systems.

different parts of the power system. Hence, to strengthen coupling between devices and subsystems the assurance of stability needs proper attention.

- **System's size and extent:** Due to the shipboard power system's limited extent, a higher level of centralized control can be applied than in commercial systems. The shorter electrical distances also facilitate easier synchronization of data and measurement retrieval than in a commercial grid.
- **Load profile:** In a shipboard power system the load profile is often rapidly changing due to the power demand from the propulsion system and other high-rated systems and equipment. Hence, the power (both active and reactive) is changing more rapidly in a shipboard power system than in commercial distribution systems.
- **Single line faults:** A shipboard power system is designed to continue operation with a single phase (line) to ground. For safety reasons such medium voltage systems always include high impedance grounding systems.
- **Environmental effects:** A shipboard power system must be able to operate in a tough environment, which is characterized by vibrations, shock and motion dynamics, and should survive salinity and moisture.

### C. Integrated Power System (IPS) and Grid Design

In an *Integrated Power System (IPS)*, or *integrated-electric ship*, all the required power, for the vessel's propulsion and auxiliary (service) loads, is generated and distributed by the same main generators. In comparison, in a conventional (segregated) *electric-drive* vessel power system, the propulsion

and the auxiliary loads are separately powered by dedicated generators [22]. Fig. 2 illustrates the main structural difference between the conventional (segregated) power system and the IPS.

The propulsion system in a conventional power system was originally a mechanical-drive system with reduction gears connecting the prime movers to propeller shafts. Many vessels were converted to electric propulsion to gain faster response, which resulted in the separated conventional electric-drive power system. Even today there exist numerous vessels with this kind of power system. As Fig. 2a indicates, the conventional power system consists of two separated subsystems; one for propulsion and one for auxiliary loads. Due to the separation between the subsystems, the engines of each subsystem are only connected to their respective systems and can only be used within that subsystem. This configuration has been the leading design for ensuring maneuverability; almost 90% of the vessel's generated power is locked into the propulsion system [34]. However, this separation, where the majority of the vessel's power supply are limited to the propulsion system, can be a disadvantage as the propulsion power is not available for other mission specific systems.

To tackle the disadvantage with the conventional power system, the IPS was introduced as a solution. Instead of separating power generating units into stand-alone subsystems, the IPS shares all generated power from all the generators on an integrated power grid, which distributes the power to all individual consumer systems located throughout the grid in a utility fashion. The IPS's ability to share the generated power between all (online) consumers is also an important property for easing aftermarket installations of electric equipment, as new equipment is simply connected to the distribution grid. The property of power sharing is the main advantage of IPS, and improves power flexibility (operational flexibility) and availability. At low- and medium-speed ranges, the IPS can generate the same amount of power as a conventional power system with fewer running prime movers. This is preferable both from an economical and an environmental point of view, as fewer running generator sets (gensets) will enhance the fuel efficiency and reduce exhaust emissions. By starting and stopping gensets relative to the vessel's power demand, the IPS provides a stepped power generation, and by equipping a vessel with gensets of different power ratings, the power production could be optimized to avoid low non-ideal loading conditions of the prime movers. However, this is seldom the case since all or multiple gensets in a vessel are often of same size to make maintenance and access to spare parts easier. In addition, if the IPS operates with open bus-ties (see Fig. 3), both sides should have the same power generating capacity. The future shipboard power system may have an elegant solution to the optimal prime mover loading problem involving Energy Storage Systems (ESS) [35], [36], that can store excess power to achieve ideal prime mover loading conditions, which, among other scenarios, can be used to give a *green* approach to harbors without emissions.

1) **Electrical Stability:** Reliability, dependability, and survivability are important properties for many shipboard power systems. A naval vessel must be able to survive an attack

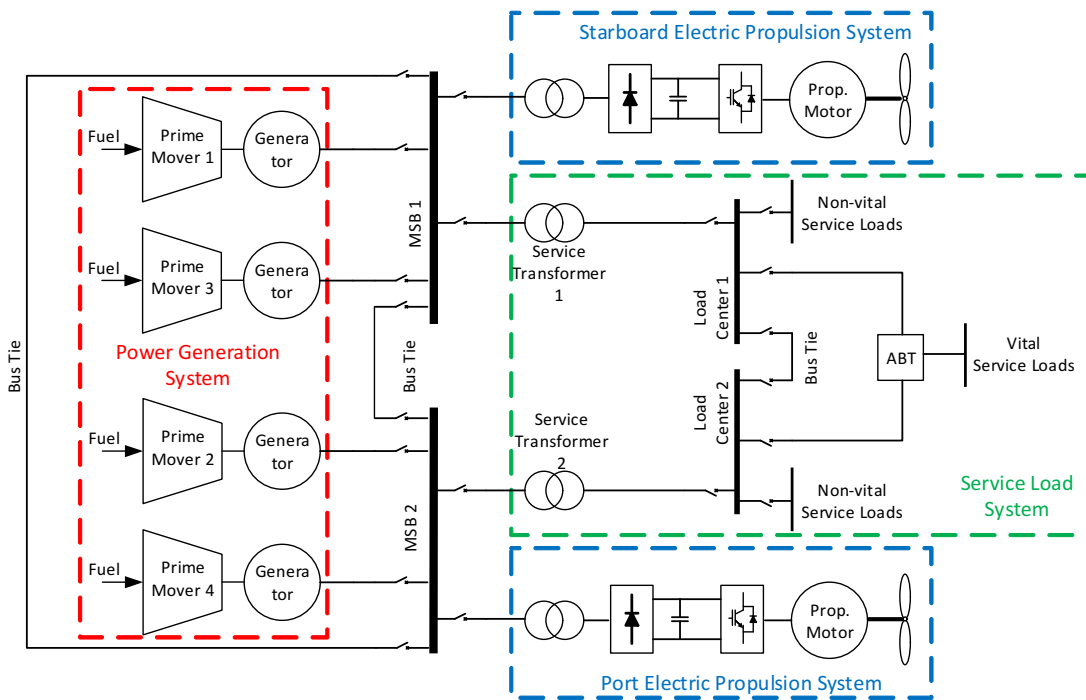

Fig. 3. Example of a typical redundant IPS for PSVs and small-medium naval ship. Redundancy for bus-tie breakers connecting Main SwitchBoard (MSB). Redundant power supply for vital loads using Automatic Bus Transfer (ABT) [22], [34].

where parts of the power system are down, but still be able to bring the ship away from the situation and have the power needed for initiating defense measures. An offshore vessel conducting a station-keeping operation (DP) near offshore structures needs to survive single faults and have the power needed to bring the vessel to a safe position away from the structures. In the same way, a deep-sea drilling vessel must have a reliable power system that survives faults and maintains station-keeping to avoid critical situations that can harm both equipment and crew.

- **Reliability** is often explained as a fail-safe operation [34], and the term *system reliability* is a standard measure for the effect of component failures and internal errors and is calculated using component mean time to failure (MTTF) statistics and static dependency analysis [37].
- **Dependability** is given as the system's ability to continue operation despite component failures, internal errors and exogenous disruptions.
- **Survivability**, on the other hand, is mostly used for naval vessels and military applications and deal with continuity of vital services during major disruptions associated with battle and damage control operations.

In many settings the terms are mixed together, and reliability often comprises both dependability and survivability. To achieve a reliable IPS, which cultivates both dependability and survivability, the most used design principle is redundancy, however, spatial separation and manual backup systems have also been used to a great extent.

An often used redundant *two-split* IPS design for small and medium size vessels is shown in Fig. 3. As can be seen, the power generating units are split in pairs, each pair connected

to a switchboard (MSB 1 and 2), and the switchboards are connected through redundant bus-ties. Each switchboard supplies one propulsion system, and both switchboards are serving the service loads. The load center is split in two switchboards. The vital service loads have redundant power supply from both switchboards using an Automatic Bus Transfer (ABT) unit, while the non-vital loads are served by one of the switchboards, one on each side of the vessel. Depending on the vessel type and class regulation from classification entities, the IPS may include an emergency generator supplying vital loads, and in some cases part of the propulsion loads. The bus-tie between the load center switchboards has the ability to connect the switchboards if, for instance, one of the service transformers fails. The IPS is equipped with many breakers, which may be used to isolate faults from propagating through the grid and causing a complete blackout. Hence, this property, *reconfigurability*, is important for achieving the needed system reliability, and is closely related to the IPS's practical design and installation, as well as fast and reliable fault detection systems that are able to invoke protection schemes isolating the faults.

2) **Radial and Zonal Grid Designs:** Traditionally, the practical solution to provide redundant power distribution was to install alternate power routes between components using longitudinal cables connecting vital loads to multiple switchboards. This solution, a *radial* distribution, was shown to be a bulky and heavy solution with the ever-increasing number of vital electrical loads. As a solution, the *zonal* distribution grid was introduced in the 1990s, where the redundant power supply was realized by providing vital loads with alternate power routes using shorter transverse feeder



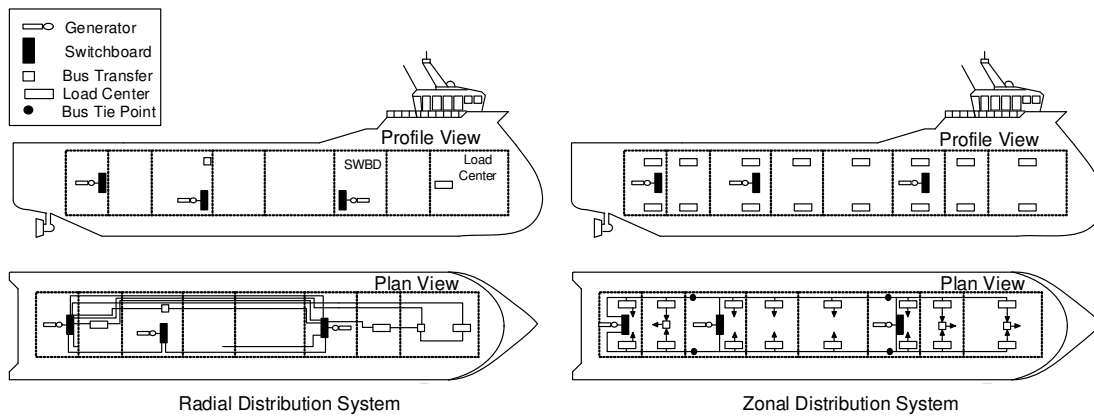

Fig. 4. Comparison of *radial* and *zonal* power distribution systems in a marine vessel [20].

cables from port and starboard switchboards [34], [37]. This may be seen as stretching the switchboards along the vessel's longitudinal axis, one switchboard for starboard side and one for port side. Bus-ties are used to isolate faults, or segregate parts of the switchboards. With this solution, the long feeder cables in a radial system are removed, with the effect of reduced cost and weight - which again leads to lower fuel consumptions and emissions. The zonal distribution topology is usually adopted in the IPS design philosophy, enabling easier aftermarket installations of equipment and more flexibility regarding installation of redundant solutions for achieving a design with the needed level of reliability and survivability at relatively low cost. An illustration showcasing the differences between radial and zonal grids is given in Fig. 4.

It is expected that tomorrow's power system design solutions will be completely different from today's solutions. Future shipboard power systems should aim for a higher quality of service (QOS), increased reliability and efficiency as key requirements, which may be achieved by, among other means, a completely new design strategy, advanced monitoring of system health and state as part of new sensor technology, and advanced and efficient stability and power quality improvement methods and devices.

#### D. Power Electronics and Harmonic Pollution

Electricity enables a more flexible way to utilize energy than any other energy source. Technology such as information systems, radar and sonar systems, advanced motion compensation, and military precision weaponry would not be possible without electricity. Future predictions show that more and more equipment is of an electrical type, and the marine vessel is asymptotically converting towards an *All-Electric Ship* (AES), where all installed equipment and systems are of an electrical type [22], [38]. The broad variety of electrical equipment and systems connected to the power system require different power conversions. Some of the equipment and systems are powered by ac, while others are powered by dc. In addition, the needed (and rated) voltage levels may span from a few volts to thousands of volts, and different systems and equipment may require different frequency levels. Almost 90% of the vessel's generated power may at some points

go to the propulsion systems [34], flowing through power electronics devices. Power electronics is at the heart of power conversion, and, because of this, the IPS includes numerous different power electronics devices to be able to supply the right form and level of power to the connected systems and equipment. The shipboard electrical power demand continues to increase, from tens of MW and in some cases even greater than 100MW [38]. However, such high power ratings lead to power electronic devices that are both heavy and have a large footprint. This is a real handicap for serving high power demands. In general, in the given order of priority, size, losses, cost, and weight are interrelated factors that limit acceptable applications of power electronics.

An important power electronic device is the converter/inverter, which is able to convert the electric power from one form to another, i.e. ac/dc, ac/ac, dc/ac, dc/dc. The necessary power for each load, or group of loads with the same power requirements, are in an IPS converted at *point-of-use*. In fact, almost all power sources and loads need a converter. Pulse-Width-Modulation (PWM)<sup>1</sup> has been widely used for modulating small- and medium size converters. A switch-mode power electronics converter, which consists of switches that are either on or off, uses PWM to control the time the switches are on and off, and by this, the converter (which in fact is an array of switches) can be programmed to produce voltage and current waveforms, different power factors, and obtain a desired frequency from a range of different input waveforms. From this point of view, there is little difference between motor drives, power supplies, and active power filters, and the composition of power electronics in such devices can be generalized to form a Power Electronics Building Block (PEBB) [39], [40]. These building blocks are intended to minimize the number of different power electronics devices in a power system and can be mass-produced due to their generality. The general design will also allow the power electronics to be tightly packed, which will reduce weight and footprint. The blocks may be controlled by different algorithms and software solutions, through a general interface (communication protocol), and can be changed in the field, depending on operational

<sup>1</sup>Often realized with a hysteresis control scheme.



status or mission type. The blocks can easily be installed (plug and play) with an interface which allows information sharing between the components. Depending on the way the blocks are connected to each other, different algorithms may be deployed as part of a configuration scheme; and, depending on the power system's status and classification requirements, different algorithms may be enabled to perform functions such as power conversion, harmonic mitigation (as an active filter), active or reactive power control, or inherit a simple breaker's properties to isolate faults. Due to its generality, a wide range of different modelling and simulation tools may be developed around this block, which will ease power system design and realization dramatically, thus ensuring stability, reliability and efficiency. An important part of developing PEBB is the continuation of improving power electronics in the sense of minimizing weight, size, and losses, to achieve components that can handle more heat and have faster dynamic response with increased power ratings. The PEBB is seen as tomorrow's solution for advanced power systems. Even though a lot of research and development has been devoted to realizing such a standardized building block, a general solution has not yet become available on the market.

A lot of research has also been conducted towards power semiconductor devices, which consist of a variety of diodes, transistors, and thyristors. New designs have produced components with better performance and lower losses, but few of the designs have reached the market. Also silicon carbide (SiC) has been devoted attention due to the material's properties which leads to lower switching losses, high voltage and high temperature capabilities. SiC devices are expensive, but have a huge impact on converter size, losses, weight, cooling requirements and potential for high PWM frequencies [20], [38], [41].

The composition and use of different power electronics to make a general PEBB will affect the shipboard power system in many ways. The transition from early solutions using Line Commutated Converters (LCC) and Cyclo-converters to today's PWM Voltage Source Converters (VSC) had many advantages, including lower harmonic pollution, four-quadrant operation and converter reversibility [42]. It is also expected that the introduction of the PEBB will lead to an increased power quality: The PEBB can be designed and controlled to achieve redundant and reliable solutions, with fewer building blocks, which minimize losses and keep the power quality higher than what is achieved in today's solutions. However, power electronics in general are non-linear elements, with non-linear behavior, and are in most cases sources of harmonic pollution. In thyristor-based devices (which is often the case in motor drives) the harmonic spectrum is not dependent on impedance, thus introduces characteristic harmonic pollutions relative to the devices' different designs. In a 6-pulse converter, the characteristic harmonics are of 5th, 7th, 11th, 13th, etc. order, and in a 12-pulse converter, the characteristic harmonics are of 11th, 13th, 23rd, 25th, etc. order. In a voltage source converter (VSC), which is not based on thyristors, these characteristic harmonics do not occur, and motor drives consisting of VSCs instead of thyristor-based drives may solve the problems with the characteristic harmonics.

However, the VSC introduces harmonics dependent on the modulation frequency, which may be 1kHz or higher. LCL filters are often used to suppress the harmonics generated by the VSC, but LCL filters are passive devices and tuned for a given modulation frequency. If, for some reasons, the VSC changes its modulation frequency the LCL filters have to be re-tuned. In addition, the harmonics from a VSC may cause harmonic resonances due to interaction with passive filters [43]. Hence, harmonic pollution can, to some extent, be suppressed by design, but the ever-increasing number of electrical devices, which are directly or indirectly dependent on power electronics, will introduce even more non-linear elements into the power system, making harmonic mitigation and power conditioning devices a necessity.

Harmonic pollution is defined as any waveform with frequencies that are multiples of the fundamental frequency, and is measured as *Total Harmonic Distortion* (THD), which is a normalized quantity describing the relation between the amplitudes of the harmonic frequencies and the amplitude of the fundamental frequency. Most shipboard power systems today are affected by harmonic pollution in some or another way [43]. Harmonic pollution, which impairs the power system's power quality, leads to higher fuel consumption and emission. Harmonics are closely connected to reactive power, and high levels of harmonics may lead to equipment and system break down, and even cause catastrophic events like explosion and fire [43]. Theoretically, this can, in the worst case, cause a complete blackout as a result of voltage collapse. A complete blackout may occur due to high levels of harmonic pollution, but is usually caused by operational mistakes. The term *voltage dip ride through capability* is often used to describe the consumers' ability to cope with faults and malfunctions where in worst case it must be assumed that the voltage becomes zero until the faults are fixed or isolated. Examples of such malfunctions and failures may be short circuits and high inrush currents while starting large motors. The allowed voltage drop is dependent on the vessel and its operations and is set by classification entities [44].

In DP-operations (e.g. DP2 [45]) with closed bus-ties, assessments regarding voltage dip ride through capability must be conducted as part of FMEA to assure continued operation after faults or malfunctions occur. Many DP-operations (station-keeping operations) are performed with open bus-tie, splitting the power system in two, thus minimizing the chances for a complete blackout. This is not an economical nor an efficient solution, as splitting the power system in two requires an increased number of online prime movers for power generation, and also requires multiple separated power management systems (PMS). Harmonic mitigation is therefore not only important for the power system's efficiency, but also for its stability and reliability. Harmonic mitigation and power conditioning is a active research topic, and many active and passive filter solutions have been proposed [46]. Passive filters do not have the ability to change their tuned frequency, and due to changes in power system configurations (and changes in load profiles) as a result of different operational requirements and mission types, passive filters are not always a good solution for harmonic mitigation as

a change in the harmonic spectrum requires a re-tuning of the filters. An active filter, on the other hand, has the ability to mitigate any frequency spectrum, the only limitation being the bandwidth of its controller, thus increasing flexibility for changes in the power system's harmonic frequency spectrum. Active filters have also a smaller footprint than passive filters, which is a desired property in marine vessels. Active filters are expensive devices, thus location of installation in a power system is important for maximum utilization (and mitigation) of the filter's power rating. A conceptual method using optimization (Model Predictive Control) to perform system level harmonic mitigation has also been proposed [47]–[50]. Active filters come in many forms, and can be part of e.g. a propulsion system's motor drive, realized as controlled Active Front End (AFE) converters or simply stand-alone devices. Harmonic mitigation (and power conditioning) is, as earlier mentioned, important for achieving an efficient and reliable power system, and the harmonic pollution problem is also expected to be an issue in future power systems, consisting of even more non-linear components. As of today, there are no classification entities that require real-time THD surveillance, which would be an important measure for detecting potential stability issues as well as performing fuel efficient operations. THD requirements are checked by classification entities during the vessel's commissioning and certification using handheld measuring devices. The future power system, where reliability and efficiency are cultivated, may require real-time THD surveillance and power conditioning devices (possible consisting of PEBBs), which may be backed on optimization for system level harmonic mitigation, to comply with stringent air pollution regulations, as well as achieving higher reliability in terms of blackout-prevention due to increased power quality.

#### E. Energy Management Systems (EMS) and Energy Storage Systems (ESS)

Planning power generation, *energy management*, is important for achieving an economical and efficient power generation with optimal prime mover loading conditions, thus keeping the fuel consumption at a minimum. In ac power systems, the prime movers are speed-controlled, mostly connected to fixed speed generators, to maintain a desired (and designed) frequency within allowable variations (deadband). As the prime movers' speeds are more or less fixed due to frequency control, the loading of each prime mover determines the fuel efficiency in terms of amount of fuel per delivered amount of useful energy - Specific Fuel Oil Consumption (SFOC)  $\frac{g}{kWh}$ . The prime movers often experience speed deviations as an effect of dynamically changing load profiles (active and reactive power demand), in which affects the inertia on the shafts between the prime movers and the generators. If such prime mover speed variations result in frequency fluctuations exceeding the allowed deadband, the prime mover needs to be isolated and shut down. Large negative frequency fluctuations can also be an indication of the running prime movers are unable to meet the load demand, thus additional supervisory steps should be taken to either shed non-essential loads or spin up idle prime movers, and after synchronization connect

them to the power system. Because of speed variations and allowed frequency fluctuations within a designed deadband, the frequency in shipboard ac power systems cannot be assumed constant.

In addition to frequency fluctuations, the speed variations on the motor shafts will also increase wear and tear leading to higher maintenance costs. Controlling the prime movers to track a constant speed greatly affects the power generation as an optimal increase or decrease in power generation is related to starting and stopping prime movers in a *stepwise* (ac) power generation [51]. As the load demand must be met at all times this means that prime movers running at low non-optimal loading conditions is often the case in shipboard ac power systems. To increase the fuel efficiency related to the power demand, the prime mover loading could be increased and power stored to be used in situations where the power demand surpasses the power generation. An example would be to provide the difference between consumed and generated power while additional prime movers are being started and connected to the power system to meet an increasing power demand.

In dc power systems, where the power distribution is conducted on dc grids, the prime movers may run at varying speeds to meet the power demand. As in ac systems, the voltage level is maintained by controlling the generators excitation fields. Due to the flexibility of being able to change the prime movers' speeds, the power generation will adopt a more *stepless* behaviour than in ac systems. However, prime movers running outside their optimal speed ranges are prone to wear and tear, and especially at low speeds the combustion is not optimal and will increase sooting of the prime movers, thus increasing maintenance costs. At high speeds the fuel consumption is not in line with the produced power (non-linear relationship between fuel consumption and produced power), thus reducing the fuel efficiency which leads to increased fuel costs and emissions. As with ac power system, the dc power system could also benefit from a ESS that facilitates optimal operation of the prime movers.

1) **ESS Applications:** Many suitable ESS technologies that facilitate a more economical and redundant operation in a marine vessel are available on the market today. The choice of ESS technology is related to area of application, energy density, size, weight, and cost, expected lifetime, charge/discharge rates, and other functional requirements. Examples of ESS technologies are Battery Energy Storage System (BESS), Compressed Air Energy Storage (CAES), flywheels, Superconducting Magnetic Energy Storage (SMES), capacitors (including ultra-capacitors) and Pumped Hydro Storage (PHS) [52]. Depending on the power system (ac or dc) most ESS technologies need power conversion devices that convert the power from and to the power system for charging and discharging purposes. An obvious application of a ESS would be to serve as a backup power source similar to an Uninterruptible Power Supply (UPS), which sets strict requirements to the ESS technology's energy density and rate of discharge. This type of application can be beneficial for many marine operations. An example would be an offshore vessel conducting a DP-operation alongside an offshore structure that

experiences faults that cause power losses which may lead to a blackout. The ESS may in this case be crucial for powering the propulsion system for a short period of time to be able to reposition the vessel at a safe distance away from the structure to get the time-window needed for isolating the faults and to re-power the vessel.

Many power consuming systems and equipment on a vessel do not have a flat load profile. Propulsion systems, while conducting station-keeping, have a load profile which correlates with waves and ocean currents. Weapons systems aboard a naval vessel may give a pulsed load profile at irregular time instants, which would be more or less impossible to predict. Due to the vessel's dynamic load profile, the energy management is not an easy task, and, as earlier mentioned, often more prime movers are running than are actually needed to be sure of serving the load demands. One application of the ESS, which is a feature that is sought for in a shipboard power system, is *load shaving* or more precisely *peak shaving* [53]. By using the ESS to flatten the vessel's total load profile, energy management, in terms of starting and stopping generators, would be easier, and fewer prime movers have to be on line to meet a potential high and instant power demand. Under low non-ideal loading conditions the ESS charges, and while the load demand exceeds the power generation capabilities the ESS discharges. Whether the power system is dc or ac, the prime movers can be run at optimal speed for maximum fuel efficiency. This feature, peak shaving, may be seen as one of the strongest arguments for installing a suitable ESS in a shipboard power system, as peak shaving may result in a lower fuel consumption (and emission) due to the need for fewer running gensets.

Another interesting application of ESS, dependent on ESS technology employed, is harmonic mitigation [34], [54]. Depending on the ESS' speed of discharge, it may be used to suppress harmonic pollution. The ESS may also be used to charge a dc capacitor in an active filter, which strengthens the filter's capabilities, and thus enables the filter to use active power in harmonic mitigation. Also frequency control by use of ESS has been proposed [55]. As an example, an ESS such as BESS may be installed alongside an Active Front End (AFE) (Fig. 5), which is a realistic scenario if for instance the ESS is part of a motor drive. In this case, when the ESS is installed alongside an AFE, the ESS could attain application flexibility, thus being able to do harmonic mitigation, peak shaving, and even act as a reactive power source or consumer to increase the power system's voltage stability margins. Fig. 5 showcases two different locations in the grid for installing a BESS. The BESS may be installed alongside an AFE or other power electronic devices which supervise the BESS state of charge (SOC) and state of health (SOH), and control charging and discharging dependent on the load demand and the BESS' SOC.

Even though the advantages of ESS in shipboard power systems are many, it doesn't come without challenges. Many of the available and suitable ESS technologies are expensive solutions, and are dependent on power conversion devices relative to ac or dc power systems. An effective solution, which was illustrated in Fig. 5b, is to install an ESS, such as BESS, as part of motor drives, thus eliminating the need for additional

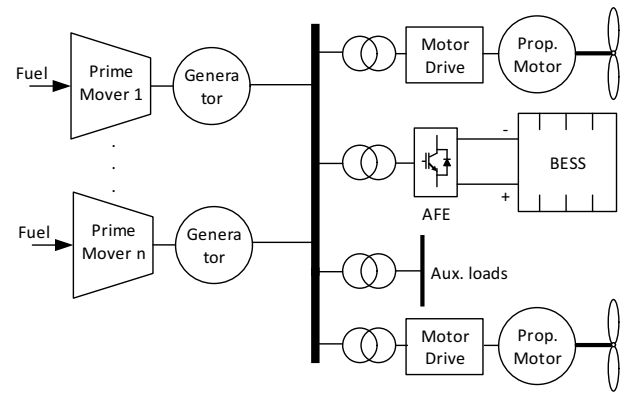

(a) Battery Energy Storage System (BESS) connected to the main bus (switchboard) in an IPS configuration. An Active Front End (AFE) is installed alongside the BESS as a solution for supervision and BESS control purposes.

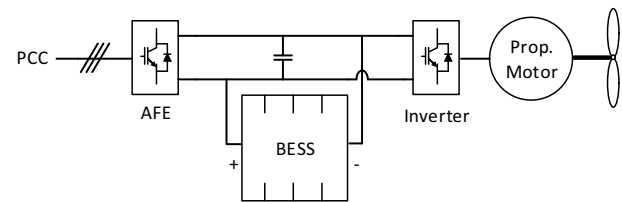

(b) Battery Energy Storage System (BESS) as part of a motor drive for propulsion systems [34]. Point of Common Coupling (PCC) refers to e.g. the vessel's main switchboard. An Active Front End (AFE) is part of the depicted motor drive and supervises charging and discharging of the BESS.

Fig. 5. Simplified illustrations of different installations of Battery Energy Storage Systems.

power conversion devices, reducing weight, footprint, and costs [34]. For BESS the available battery technology also introduces challenges, as the battery packs are heavy (relative to power capacity) and in many cases have a large footprint. Despite weight and volume, the BESS may allow removal of one prime mover from a vessel, which justifies the use of BESS. Another issue is the battery packs' lifetime. Rapid charging and discharging of battery generates a lot of heat, which can be seen as losses, and may have critical effect on the battery's life. Thus a possible realistic outcome is that the battery pack dies before the BESS manages to pay back the installation costs by reduced fuel consumption. In some applications ultracapacitors or fuel cells can switch places with the battery pack, giving the energy storage system different properties such as increased lifetime, charge/discharge speed, energy density relative to footprint and weight, etc. Also hybrid energy storage systems, including different energy storage devices, may also be interesting possibilities, thus increasing applications and system flexibility [56], [57].

When moving towards all electric-battery powered vessels, a new emerging technology -the inductive charging technology- has attracted the attention of the marine vessel community and the old concept of *Inductive Power Transfer* has re-emerged for contactless battery charging of marine vessels [58]–[60]. Significant progress toward the development of commercial solutions for wireless charging is already on its way for high power wireless transfer in the MW range [61].

This technology will greatly benefit coastal vessels operating with a tight schedule as it will significantly reduce charging time and improve reliability. This will bring unavoidable challenges to the local power grid from which high power will be tapped in a short time to charge the vessel's battery packs. This impending impact on the local electrical grid will require grid reinforcements and new solutions that will require collaborative efforts between the utility and marine vessel sectors.

2) **Standards and Guidelines:** Many classification entities and interest groups impose strict regulations and set forth guidelines for redundancy for many types of marine vessels to avoid total loss of maneuverability. This is mostly the case for offshore vessels, like PSVs, but the requirements can also be found for passenger vessels and cargo vessels transporting hazardous materials. The *International Marine Contractors Association* (IMCA) [62] states (for an offshore vessel) that *if there is a realistic chance of the bus-ties not opening or not opening fast enough then the switchboard should be split for the work* (two-split in Fig. 3), *and if so the power system must include an independent power system (Power/Energy Management System - PMS/EMS) for each individual split* [63]. Furthermore IMCA states that *for a diesel-electric vessel a task appropriate mode could mean operating with closed bus-ties, whereas a critical activity mode of operation may require open bus-tie configuration* [64]. These guidelines are based on risk assessments (Failure Modes and Effect Analysis - FMEA) and fault tolerance (isolation of faults) dependent on classification and control system redundancy [65]. DNV-GL (earlier DNV) [66] describes that the traditional interpretation of the DP-3 requirements has been to run the power system as separated (segregated) subsystems with open bus-tie breakers. This is backed on IMO [67] MSC/Circ.645 guidelines for vessels with dynamic positioning systems, which states that *for equipment of class 3 the power system should be divisible into two or more systems such that in the event of failure of one system, at least one other system will remain in operation* [68]. However, closed bus-tie DP operations have economical, technical, operational, and environmental benefits, thus some DP operators run the power system with closed bus-ties for as large periods of operation as possible [45], [69]. ABS [70] also refers to the IMO MSC/Circ.645 guidelines, and states that these guidelines should be followed in the design of DPS-2 (DPS - Dynamic Positioning System) and DPS-3 systems where loss of position is not allowed to occur in the event of a single fault [71]. For ships normally operating in transit, such as tankers and cargo ships, the equivalent concept is redundant propulsion as described in e.g. DNV-GL's class notation RP. In short, all these regulations and guidelines state that, dependent on the vessel's classification, one should not lose maneuverability, and due to the fact that it has been difficult to both engineer completely fail-safe power systems and prove that there is no chance for power losses impairing the maneuverability, the trend has been to operate the power systems with open bus-ties (a split power system). This type of operation increases the number of needed online prime movers, which results in lower efficiency (higher fuel consumption) and increased emissions. To be able to

close the bus-ties in all operational scenarios would be a necessity for future power systems with increased efficiency and stringent emission requirements. To achieve this, the power systems must be equipped with stability-improving systems and devices that, in a safe way, handle faults without harming the rest of the power system. Such systems may involve harmonic mitigation, reactive power control, voltage and frequency control, peak (load) shaving, UPS systems and advanced power system segregation and fault-isolation systems. In order to take advantage of new technological developments to increase operational flexibility without increasing risk, DNV-GL recently introduced the DYNPOS-ER (Enhanced Reliability) notation for DP class 2 and 3 vessels.

3) **Emission Free Operation:** In tomorrow's shipboard power systems the BESS (or another suitable ESS) may be essential to cultivate reliable and efficient power systems (both ac and dc), and applications such as harmonic mitigation, peak shaving, reactive power control (voltage stability), voltage and frequency control, and backup power can simply be different algorithms deployed to a PEBB-based ESS. It is also expected that in the near future harbors may require an emission-free approach for vessels to load and unload, thus an ESS may be part of a larger *green* system keeping the air pollution (emission) in harbors at a minimum. In addition, the EMS must be intuitive and easy to understand, and provide supportive and advisory actions which are trusted by the operators. Many EMS systems today are hard to understand, as a result they are disregarded by the operators and kept out of the control loop with the effect being an inefficient power system. A lot of work remains to map the operators' behaviors and interaction with the system to make an optimal, reliable, and trustworthy interaction for efficient and economical control of the shipboard power systems.

#### F. Increasing Need for Measurements, Big-Data, and Software Complexity

To achieve a reliable and efficient shipboard power system, many different measurements are needed. Active power measurements (voltage and current measurements) are important for the EMS to be able to meet the load demand, and an ESS needs power measurements for conducting peak shaving. In ac distribution systems reactive power measurements (voltage and current measurements) are important for voltage stability assessments, and give a measure of the system's efficiency. Frequency measurements are needed in ac distribution systems as feedback to the prime movers' speed controllers. Voltage measurements are needed for controlling the generators' excitation fields, which are done by Automatic Voltage Regulators (AVR), and also for transformers and power converters connecting equipment and subsystems (including energy storage systems) to the power system need voltage measurements. When starting a prime mover and connecting it to the grid in a synchronization process both phase and voltage measurements are needed. Voltage measurements with high sampling frequency are needed for harmonic mitigation, to assure voltage quality within boundaries set by classification entities. These are only a few examples of needed measurements.

Many parts of the power system have high real-time demands (high sampling frequency demands) for measurements. Harmonic mitigation using Active Power Filters (APF) and power converters such as Active Front Ends (AFE) are examples of systems that require (internal or external) a high rate of sampling measurements. In addition, fast hardware and software is required to process the measurements in real-time to be able to utilize the information for control purposes. Redundancy in measurement devices (sensors) is also a requirement for achieving a reliable system. If one measurement device goes down another has to take over to keep the needed information to the system flowing. Redundancy in measurement devices comes in many forms, and a common approach in systems that relies on correct information is to have a minimum of three measurement devices and use voting algorithms to assure the correctness of the measurement information.

Some measurements may be contaminated by noise, and communication delays between taking the measurement and sending it to the subscribing system may make the information no longer valid. Thus the use of filtering techniques for removing noise, and estimators for estimating biases and transport delays may in some cases be a necessary requirement for optimal control, giving the subscribing system correct and valid information. Advanced signal processing methods may also be used to detect and solve measurement drop-outs as part of a solution to redundancy requirements for improving system reliability.

With increasing system integrity that cultivates both efficiency and reliability of the shipboard power system, there is also an increasing need for measurements. The present trend shows that more and more devices and subsystems are given an IP-address and system information and measurements are broadcast on a local network in the vessel in a cloud-based architecture - *The Industrial Internet of Things (IIoT)*. As a consequence the future system integrity may involve consumer systems planning their power consumption, which is available information for the EMS for use in power generation planning.

With the expected enormous amount of data as a consequence of an increase in measurement devices and broadcasting of system information to get more efficient and reliable control, problems such as limited network throughput and data processing resources may appear. Maybe the most frightening issue is that when all the vessel's systems "come online", the vessel is vulnerable to cyber-attacks. Even though an increase in available system information, measurement data, and distributed control may be beneficial for controlling the vessel's power system in an optimal, reliable, and efficient way, the development of the future shipboard power systems have to address the *Big-Data* challenge in the design of its architecture and assure cyber-security. There exists a range of different types of cyber-attacks, some of which are based on gaining access to data and information, and others that are disruptive and intended to take over or break down a system. The latter may have catastrophic consequences if they enable the attacks that gain control over the vessel's power and propulsion system. A small selection of potential external and internal cyber-attacks will be treated separately in the

following:

- **External cyber-attacks** can be classified as cyber-attacks originating remotely from the marine vessels. There are different strategies for protecting the vessel from such attacks. A vessel's access point to the rest of the world and potential remote systems, which normally is a 3 layer switch, has authentication and VPN capabilities which provide basic security. The switch can also limit input and output network ports, which restrict the communication channel. By enabling only output ports, the vessel data can be encrypted and exported to e.g. onshore fleet management systems without allowing any input traffic from a potential cyber-attack. A practical approach is described by DNV-GL [72], where the main access point to remote systems is to be powered on only when allowed by the vessel's crew. Another form of attack is related to connection to other equipment or systems that are infected. An example of such a case might be the vessel's shore power connection while docking, where the shore power is altered to harm the vessel's power system and put the vessel out of operation. Another example could be infection of onshore fleet management systems, or other vessels within the same fleet that have dedicated ship-to-ship communication equipment.
- **Internal cyber-attacks** can be classified as attacks originating within the marine vessel. This could either be a passenger or trusted insider (crew) that gains control over, or infects, one of the vessel's distributed control system nodes. The cyber-attacks could be based on malware delivery by a USB stick or different internal access interfaces such as an Ethernet that connects the vessel's office network to the control system network. These types of attacks are more difficult to handle, however procedures such as disabling unused potential access points (such as USB connections) and limiting input and output ports on the router that connects the office network to the control system network can reduce the risk of internal cyber-attacks. If one of the distributed control nodes gets infected it is important to isolate that controller from the rest of the system. However, to quickly realize and identify the attack before any harm is done might be a challenge, which puts stringent requirements on the vessel's distributed control system's middleware to limit potential attacks [73]. Such requirements can be based on each control node's accessibility and level of security clearance to distribute control actions to the rest of the vessel's control nodes. If for instance the middleware detects that one of the control nodes tries to control parts of the system outside the controller's security clearance, e.g. the vessel's prime movers or propulsors, it might be considered as an attack, which should trigger isolation procedures and alert the crew. In addition, it is essential to keep operation systems and firmware up to date to be more resistant to cyber-attacks.

There is a drive towards increased fuel optimality, reduction of emissions, increased safety, and performance and operational flexibility. The technologies that are supporting this

development tend to increase system complexity, which has consequences for ship designers, ship builders, ship owners, crew and other stakeholders such as classification societies and authorities. Like the automotive and aerospace industries, the electric power plant is a highly computer controlled system with advanced functionality offering endless user configurations and options embedded in software. The control of the power plant itself is also integrated with the control of power consumers, e.g. [74]. This leads to more complex processes with new tasks, skills and training required by the crew. Due to the safety-critical nature of the ship's power plant and electric system, the maritime industry is looking to learn from the automotive, aerospace, and defense industries that have experienced the paradigm shift due the huge impact of information and communication technology. This has led to new standards, certification, and classification schemes related to integrated systems development and more extensive use of simulator-based training and verification technologies, [75], [76]. Future visions for unmanned and autonomous shipping, [77], [78], are indicators of the opportunities and challenges that are emerging.

## V. CONCLUSION

Past, present, and future challenges in the electrification of the marine vessel have been discussed in this paper. The milestones in the evolution of the development of marine vessels, from the earliest introduction of electricity in commercial vessels with the *SS Columbia* in 1880 to the new era of the all electric vessels marked by the *Ampere* ferry, have been highlighted in the historical part of the paper. The use of electricity in marine vessels which started far from the idea of an electric power system on board has, however, spurred the development of electric propulsion systems, and also the concept of the integrated power system. The electrical system of today's marine vessels can be compared to a land-based stand-alone microgrid system, with which the marine vessel power system shares many common features. Present and future challenges include issues such as harmonics, power quality, fault handling, and stability. These issues will be as relevant during normal operation of the marine vessel as they are at commissioning today. Many of the features required today to handle the modern land-based electrical system (smart grid) will be a necessity in marine vessels as the use of electricity becomes more intensive. Characterization of the marine vessel electrical grid through real-time measurements, and the monitoring of fundamental parameters such as impedance in addition to fundamental and harmonic currents and voltages, will be essential to ensure the safety, integrity, and stability of the marine vessel power system. Lately, re-emerging wireless power transfer for battery pack charging in vessels will make the link between the land-based power grid and the marine vessel power grid even tighter and will create a new form of interaction. Ultimately, as the use of all electric ships becomes widespread, the electric vessel will become a part of the land-based power grid as a high impact electric load, thus bringing new challenges. This paper aims at anticipating the potential new challenges and the associated research needs

for the future by stimulating the discussion and identifying synergies between the modern power grid and the electrical grid of the marine vessels today.

## ACKNOWLEDGMENT

This work has been carried out at the Centre for Autonomous Marine Operations and Systems (AMOS) whose main sponsor is The Research Council of Norway. The work was supported by Ulstein Power & Control AS and The Research Council of Norway, Project number 241205.

## REFERENCES

- [1] L. Horne, *Electric propulsion of ships*. North East Coast Institution of Engineers and Shipbuilders, 1939.
- [2] E. Skjong, E. Rødskar, M. Molinas, T. Johansen, and J. Cunningham, "The Marine Vessel's Electrical Power System: From its Birth to Present Day," *Proceedings of the IEEE*, vol. 103, no. 12, pp. 2410–2424, Dec 2015.
- [3] C. Sulzberger, "First Edison Lights at Sea: The SS Columbia Story, 1880-1907 [history]," *Power and Energy Magazine, IEEE*, vol. 13, no. 1, pp. 92–101, Jan 2015.
- [4] Siemens, "Electrical Propulsion Systems," [http://w3.siemens.no/home/no/no/sector/industry/marine/pages/electrical\\_propulsion\\_systems3.aspx](http://w3.siemens.no/home/no/no/sector/industry/marine/pages/electrical_propulsion_systems3.aspx), accessed: 2015-12-22.
- [5] A. A. Halacsy and G. H. von Fuchs, "Transformer invented 75 years ago," *Electrical Engineering*, vol. 80, no. 6, pp. 404–407, June 1961.
- [6] J. J. Cunningham, "Manhattan Electric Power Distribution, 1881-1901," *Proceedings of the IEEE*, vol. 103, no. 5, pp. 850–858, 2015.
- [7] H. F. Harvey Jr and W. Thau, "Electric propulsion of ships," *Transactions of the American Institute of Electrical Engineers*, vol. 44, pp. 497–522, 1925.
- [8] T. McCoy, "Electric Ships Past, Present, and Future [Technology Leaders]," *IEEE Electrification Magazine*, vol. 3, no. 2, pp. 4–11, June 2015.
- [9] W. McBride, *Technological Change and the United States Navy, 1865–1945*, ser. Johns Hopkins Studies in the History of Technology. Johns Hopkins University Press, 2000.
- [10] D. Dyal, B. Carpenter, and M. Thomas, *Historical Dictionary of the Spanish American War*, ser. Gale virtual reference library. Greenwood Press, 1996.
- [11] E. Smith, *A short history of naval and marine engineering*. Cambridge University Press; Reissue edition (October 31, 2013), 1938.
- [12] P. Fontenoy, *Submarines: An Illustrated History of Their Impact*, ser. Weapons and warfare series. ABC-CLIO, 2007.
- [13] S. Sandler, *World War II in the Pacific: An Encyclopedia*, ser. Garland Military History of the United States. Garland Pub., 2001.
- [14] P. S. Dawson, *British Superliners of the Sixties: A Design Appreciation of the Oriana, Canberra and QE2*. London: Conway Maritime Press, 1990.
- [15] —, *Canberra: In the Wake of a Legend*. Conway Maritime Press, 1997.
- [16] N. Polmar and K. Moore, *Cold War Submarines: The Design and Construction of U.S. and Soviet Submarines*. Brassey's, 2004.
- [17] W. Donnelly, *Nuclear Power and Merchant Shipping*, ser. Nuclear Power and Merchant Shipping. U.S. Atomic Energy Commission, Division of Technical Information, 1964, no. v. 7.
- [18] "NAVSEA Design Practices and Criteria Manual, Electrical Systems for Surface Ships, Chapter 300," Naval Sea Systems Command (NAVSEA), NAVSEA T9300-AF-PRO-020.
- [19] N. H. Doerry and D. H. Clayton, "Shipboard electrical power quality of service," in *Electric Ship Technologies Symposium, 2005 IEEE*. IEEE, 2005, pp. 274–279.
- [20] N. Doerry, "Naval Power Systems: Integrated power systems for the continuity of the electrical power supply," *IEEE Electrification Magazine*, vol. 3, no. 2, pp. 12–21, June 2015.
- [21] "International Maritime Organization: Prevention of Air Pollution from Ships," <http://www.imo.org/en/OurWork/Environment/PollutionPrevention/AirPollution/Pages/Air-Pollution.aspx>, accessed: 2015-08-21.
- [22] M. Patel, *Shipboard Electrical Power Systems*, ser. Shipboard Electrical Power Systems. Taylor & Francis, 2011.
- [23] M. Hanna, "Voltage transformation." May 14 1912, US Patent 1,026,391.

- [24] V. Staudt, R. Bartelt, and C. Heising, "Fault scenarios in dc ship grids: The advantages and disadvantages of modular multilevel converters," *IEEE Electrification Magazine*, vol. 3, no. 2, pp. 40–48, 2015.
- [25] M. Baran and N. Mahajan, "Dc distribution for industrial systems: opportunities and challenges," *IEEE Trans. Ind. Appl.*, vol. 39, no. 6, pp. 1596–1601, Nov 2003.
- [26] G. Reed, B. Grainger, A. Sparacino, and Z.-H. Mao, "Ship to grid: Medium-voltage dc concepts in theory and practice," *IEEE Power and Energy Magazine*, vol. 10, no. 6, pp. 70–79, Nov 2012.
- [27] R. E. Hebner, F. M. Uriarte, A. Kwasinski, A. L. Gattozzi, H. B. Estes, A. Anwar, P. Cairolì, R. A. Dougal, X. Feng, H.-M. Chou, L. J. Thomas, M. Pipattanasomporn, S. Rahman, F. Katiraei, M. Steurer, M. O. Faruque, M. A. Rios, G. A. Ramos, M. J. Mousavi, and T. J. McCoy, "Technical cross-fertilization between terrestrial microgrids and ship power systems," *Journal of Modern Power Systems and Clean Energy*, pp. 1–19, 2015.
- [28] A. Vicenzutti, D. Bosich, G. Giadrossi, and G. Sulligoi, "The role of voltage controls in modern all-electric ships: Toward the all electric ship," *IEEE Electrification Magazine*, vol. 3, no. 2, pp. 49–65, 2015.
- [29] S.-J. Ahn, J.-W. Park, I.-Y. Chung, S.-I. Moon, S.-H. Kang, and S.-R. Nam, "Power-sharing method of multiple distributed generators considering control modes and configurations of a microgrid," *IEEE Trans. Power Del.*, vol. 25, no. 3, pp. 2007–2016, 2010.
- [30] R. Lasseter, "Microgrids," in *Power Engineering Society Winter Meeting, 2002. IEEE*, vol. 1, 2002, pp. 305–308 vol.1.
- [31] T. Vandoom, B. Renders, L. Degroote, B. Meersman, and L. Vandeveld, "Active load control in islanded microgrids based on the grid voltage," *IEEE Trans. Smart Grid*, vol. 2, no. 1, pp. 139–151, March 2011.
- [32] J. Lopes, C. Moreira, and A. Madureira, "Defining control strategies for microgrids islanded operation," *IEEE Trans. Power Syst.*, vol. 21, no. 2, pp. 916–924, 2006.
- [33] B. Kroposki, R. Lasseter, T. Ise, S. Morozumi, S. Papatlianassiou, and N. Hatziaaryiou, "Making microgrids work," *IEEE Power and Energy Magazine*, vol. 6, no. 3, pp. 40–53, 2008.
- [34] S. Kim, S. Choe, S. Ko, and S. Sul, "A naval integrated power system with a battery energy storage system: Fuel efficiency, reliability, and quality of power," *IEEE Electrification Magazine*, vol. 3, no. 2, pp. 22–33, June 2015.
- [35] H. Ibrahim, A. Ilinca, and J. Perron, "Energy storage systems characteristics and comparisons," *Renewable and sustainable energy reviews*, vol. 12, no. 5, pp. 1221–1250, 2008.
- [36] R. Hebner, K. Davey, J. Herbst, D. Hall, J. Hahne, D. Surls, and A. Ouroua, "Dynamic load and storage integration," *Proceedings of the IEEE*, vol. 103, no. 12, pp. 2344–2354, Dec 2015.
- [37] E. Zivi, "Design of robust shipboard power automation systems," *Annual Reviews in Control*, vol. 29, no. 2, pp. 261 – 272, 2005.
- [38] T. Ericson, N. Hingorani, and Y. Khersonsky, "Power electronics and future marine electrical systems," in *Petroleum and Chemical Industry Technical Conference, 2004. Fifty-First Annual Conference 2004*, Sept 2004, pp. 163–171.
- [39] T. Ericson and A. Tucker, "Power electronics building blocks and potential power modulator applications," in *Conference Record of the 1998 Twenty-Third International Power Modulator Symposium, 1998*, Jun 1998, pp. 12–15.
- [40] T. Ericson, "Power electronic building blocks - a systematic approach to power electronics," in *IEEE Power Engineering Society Summer Meeting, 2000*, vol. 2, 2000, pp. 1216–1218 vol. 2.
- [41] —, "Future navy application of wide bandgap power semiconductor devices," *Proceedings of the IEEE*, vol. 90, no. 6, pp. 1077–1082, Jun 2002.
- [42] M. Lehti, P. Hyvarinen, and T. Tissari, "The new generation of propulsion drive systems," in *All Electric Ship 2003 Conference, 2003*, pp. 13–14.
- [43] T. Hoevenaars, I. Evans, and A. Lawson, "New marine harmonic standards," vol. 16, no. 1, January 2010, pp. 16–25.
- [44] M. Bollen, M. Stephens, S. Djokic, K. Stockman, B. Brumsickle, J. Milanovic, J. R. Gordón, R. Neumann, G. Ethier, F. Corcoles *et al.*, "Voltage dip immunity of equipment and installations," *Prepared by the members of CIGRE/CIREU/UIE Joint Working Group C*, vol. 4, 2010.
- [45] DNV, "Dynamic Positioning Systems," <http://www.dnv.com>, July 2014, Rules for Classification of Ships, Part 6, Chapter 7.
- [46] H. Akagi, E. Watanabe, and M. Aredes, *Instantaneous Power Theory and Applications to Power Conditioning*, ser. IEEE Press Series on Power Engineering. Wiley, 2007.
- [47] E. Skjong, M. Ochoa-Gimenez, M. Molinas, and T. A. Johansen, "Management of harmonic propagation in a marine vessel by use of optimization," in *2015 IEEE Transportation Electrification Conference and Expo (ITEC)*. IEEE, 2015, pp. 1–8.
- [48] E. Skjong, M. Molinas, and T. A. Johansen, "Optimized current reference generation for system-level harmonic mitigation in a diesel-electric ship using non-linear model predictive control," in *2015 IEEE International Conference on Industrial Technology (ICIT)*. IEEE Conference Publications, 2015, pp. 2314–2321.
- [49] E. Skjong, M. Molinas, T. A. Johansen, and R. Volden, "Shaping the current waveform of an active filter for optimized system level harmonic conditioning," in *Proceedings of the 1st International Conference on Vehicle Technology and Intelligent Transport Systems*, 2015, pp. 98–106.
- [50] E. Skjong, J. A. Suul, A. Rygg, M. Molinas, and T. A. Johansen, "System-wide harmonic mitigation in a diesel electric ship by model predictive control," *IEEE Trans. Ind. Electron.*, 2016, manuscript accepted for publication.
- [51] K. Davey, "Ship component in hull optimization," *Marine Technology Society Journal*, vol. 39, no. 2, pp. 39–46, 2005.
- [52] Z. Zhou, M. Benbouzid, J. F. Charpentier, F. Scuiller, and T. Tang, "A review of energy storage technologies for marine current energy systems," *Renewable and Sustainable Energy Reviews*, vol. 18, pp. 390–400, 2013.
- [53] A. Oudalov, R. Cherkaoui, and A. Beguin, "Sizing and optimal operation of battery energy storage system for peak shaving application," in *IEEE Lausanne Power Tech, 2007, July 2007*, pp. 621–625.
- [54] K. Divya and J. stergaard, "Battery energy storage technology for power systemsan overview," *Electric Power Systems Research*, vol. 79, no. 4, pp. 511 – 520, 2009.
- [55] A. Oudalov, D. Chartouni, and C. Ohler, "Optimizing a battery energy storage system for primary frequency control," *IEEE Trans. Power Syst.*, vol. 22, no. 3, pp. 1259–1266, Aug 2007.
- [56] A. Khaligh and Z. Li, "Battery, ultracapacitor, fuel cell, and hybrid energy storage systems for electric, hybrid electric, fuel cell, and plug-in hybrid electric vehicles: State of the art," *IEEE Trans. Veh. Technol.*, vol. 59, no. 6, pp. 2806–2814, July 2010.
- [57] P. Ribeiro, B. Johnson, M. Crow, A. Arsoy, and Y. Liu, "Energy storage systems for advanced power applications," *Proceedings of the IEEE*, vol. 89, no. 12, pp. 1744–1756, Dec 2001.
- [58] G. Maggetto and P. Van den Bossche, "Inductive Automatic Charging—The Way to Safe, Efficient and User-Friendly Electric Vehicle Infrastructure," in *Electric Vehicle Symposium EVS-18*, 2001, pp. 20–24.
- [59] G. Covic, J. T. Boys *et al.*, "Modern trends in inductive power transfer for transportation applications," *IEEE Journal of Emerging and Selected Topics in Power Electronics*, vol. 1, no. 1, pp. 28–41, 2013.
- [60] A. Brecher and D. Arthur, "Review and Evaluation of Wireless Power Transfer (WPT) for Electric Transit Applications," Tech. Rep., 2014.
- [61] G. Guidi and J. A. Suul, "Minimization of converter ratings for mw-scale inductive charger operated under widely variable coupling conditions," in *2015 IEEE PELS Workshop on Emerging Technologies: Wireless Power (WoW)*. IEEE, 2015, pp. 1–7.
- [62] IMCA, "<http://www.imca-int.com/>"
- [63] —, "Guidelines for The Design and Operation of Dynamically Positioned Vessels," <http://www.imca-int.com>, December 2007, IMCA M 103 Rev. 1.
- [64] —, "International Guidelines for The Safe Operation of Dynamically Positioned Offshore Supply Vessels," <http://www.imca-int.com>, April 2015, IMCA 182 MSF Rev. 2.
- [65] —, "A Guide to DP Electrical Power and Control Systems," <http://www.imca-int.com>, November 2010, IMCA M 206.
- [66] DNV-GL, "<https://www.dnvgl.com/>"
- [67] IMO, "<http://www.imo.org/>"
- [68] —, "Guidelines for Vessels with Dynamic Positioning Systems," <http://www.imo.org>, June 1994, MSC/Circ.645.
- [69] DNV, "Failure Mode and Effect Analysis (FMEA) of Redundant Systems," <http://www.dnv.com>, January 2012, DNV-RP-D102.
- [70] ABS, "<http://ww2.eagle.org/>"
- [71] —, "Guide for Dynamic Positioning Systems," <http://ww2.eagle.org/>, November 2013.
- [72] DNV-GL, "Recommended Practice: Safety, operation and performance of grid-connected energy storage systems," <https://www.dnvgl.com/>, December 2015, DNVGL-RP-0043.
- [73] C. Esposito and M. Ciampi, "On security in publish/subscribe services: A survey," *Communications Surveys & Tutorials, IEEE*, vol. 17, no. 2, pp. 966–997, 2015.
- [74] E. Mathiesen, B. Realfsen, and M. Breivik, "Methods for reducing frequency and voltage variations on DP vessels," in *MTS Dynamic Positioning Conference, Houston, TX*, 2012.



- [75] T. A. Johansen and A. J. Sørensen, "Experiences with HIL simulator testing of power management systems," in *MTS Dynamic Positioning Conference, Houston, TX, 2009*.
- [76] T. I. Bø, A. R. Dahl, T. A. Johansen, E. Mathiesen, M. R. Miyazaki, E. Pedersen, B. Rokseth, R. Skjetne, A. J. Sørensen, L. Thorat, I. B. Utne, and K. K. Yum, "Real-time marine vessel and power plant simulator," in *ASME 34th International Conference on Ocean, Offshore and Arctic Engineering (OMA2015) in St. John's, Newfoundland, Canada, 2015*.
- [77] Rolls-Royce-Marine, "Rolls-royce drone ships challenge \$375 billion industry: Freight," <http://www.bloomberg.com/news/articles/2014-02-25/rolls-royce-drone-ships-challenge-375-billion-industry-freight>, 2014, accessed: 2015-09-26.
- [78] DNV-GL, "The revolt – a new inspirational ship concept," <https://www.dnvgl.com/technology-innovation/revolt/index.html>, 2015, accessed: 2015-09-26.



**Espen Skjong** received his MSc degree in Engineering Cybernetics at NTNU in 2014, specializing in model predictive control (MPC) for autonomous control of UAVs. He is currently employed in Ulstein Power & Control AS as an industrial PhD candidate. His research topic is optimization within marine vessel power systems. His industrial PhD fellowship is with the Center of Excellence on Autonomous Marine Operations and Systems (AMOS) at NTNU.



**Rune Volden** received his BSc Hons. deg. at UMIST (University of Manchester) in 1989. He attended Junior Officer School at Royal Norwegian Marine 1991 (Submarine). He finished his PhD at Norwegian University of Science and Technology in 1995. He was Associate Professor at Østfold Engineering College in 1994 - 1995. He has 20 years of industrial research and development experience in automatic control within production machines and maritime applications, e.g. dynamic positioning, winch control and automation. He was chairman and member of

the board for Norwegian Society of Automatic Control (NMO of IFAC) 2009-2014. He is currently R&D manager at Ulstein Power & Control AS and Associate Professor at NTNU Campus Ålesund.



**Egil Rødskar** received his BSc degree in Electrical Power Systems from Møre og Romsdal Ingeniør Høgskole (MRIH) in 1987. He is currently a Technical Manager within Systems with Ulstein Power & Control AS, Ulsteinvik, Norway. He has 25 years of experience in marine electrical system engineering and project management for installation and commissioning of marine electrical systems. His experience also covers failure mode and effect analysis (FMEA), failure mode, effect and criticality analysis (FMECA) for marine ship systems and

knowledge of ship operations.



**Marta Molinas** (M'94) received the Master of Engineering degree from Ryukyu University, Japan, in 1997, and the Doctor of Engineering degree from the Tokyo Institute of Technology, Tokyo, Japan, in 2000. She was a Guest Researcher with the University of Padova, Padova, Italy, during 1998. From 2008-2014 she has been professor at the Department of Electric Power Engineering at the Norwegian University of Science and Technology (NTNU). From 2008 to 2009, she was a Japan Society for the Promotion of Science (JSPS) Research Fellow with the Energy Technology Research Institute, National Institute of Advanced Industrial Science and Technology, Tsukuba, Japan. In 2014, she was Visiting Professor at Columbia University and Invited Fellow by the Kingdom of Bhutan working with renewable energy microgrids for developing regions. She is currently Professor at the Department of Engineering Cybernetics, NTNU. Her research interests include stability of power electronics systems, harmonics, oscillatory phenomena, and non-stationary signals from the human and the machine. Dr. Molinas has been an AdCom Member of the IEEE Power Electronics Society. She is Associate Editor and Reviewer for *IEEE Transactions on Power Electronics* and *PELS Letters*.



**Tor Arne Johansen** (M'98, SM'01) received the MSc degree in 1989 and the PhD degree in 1994, both in electrical and computer engineering, from the Norwegian University of Science and Technology (NTNU), Trondheim, Norway. From 1995 to 1997, he worked at SINTEF ICT as a researcher before he was appointed Associated Professor at NTNU in Trondheim in 1997 and Professor in 2001. He has published several hundred articles in the areas of control, estimation and optimization with applications in the marine, automotive, biomedical and process industries. In 2002 Johansen co-founded the company Marine Cybernetics AS where he was Vice President until 2008. Prof. Johansen received the 2006 Arch T. Colwell Merit Award of the SAE, and is currently a principal researcher within the Center of Excellence on Autonomous Marine Operations and Systems (AMOS) and director of the Unmanned Aerial Vehicle Laboratory at NTNU.



**Joseph Cunningham** received the B.S. degree in physics from St. Francis College of Brooklyn Heights, Brooklyn, NY, USA. His interest in electric power systems dates to his youth when his high school science project, "The Theory and Operation of Alternating Current," was awarded a first-place gold medal. This success led to a scholarship and a degree in physics from St. Francis College of Brooklyn Heights, Brooklyn, NY, USA. He has researched and authored numerous booklets, articles, and books on topics such as industrial electrification, electric utility power systems, and electric rail transportation. His latest book, *New York Power*, was published in 2013 by the IEEE History Center Press. In 1976, he coauthored a definitive three-volume *History of the New York City Subway System*. He has also lectured and taught widely on the history of electrotechnology and has consulted on numerous history projects and television productions.